

Communication set In-Ear with ambient sound reception (CT-ClipCom Digital)

Operation instructions

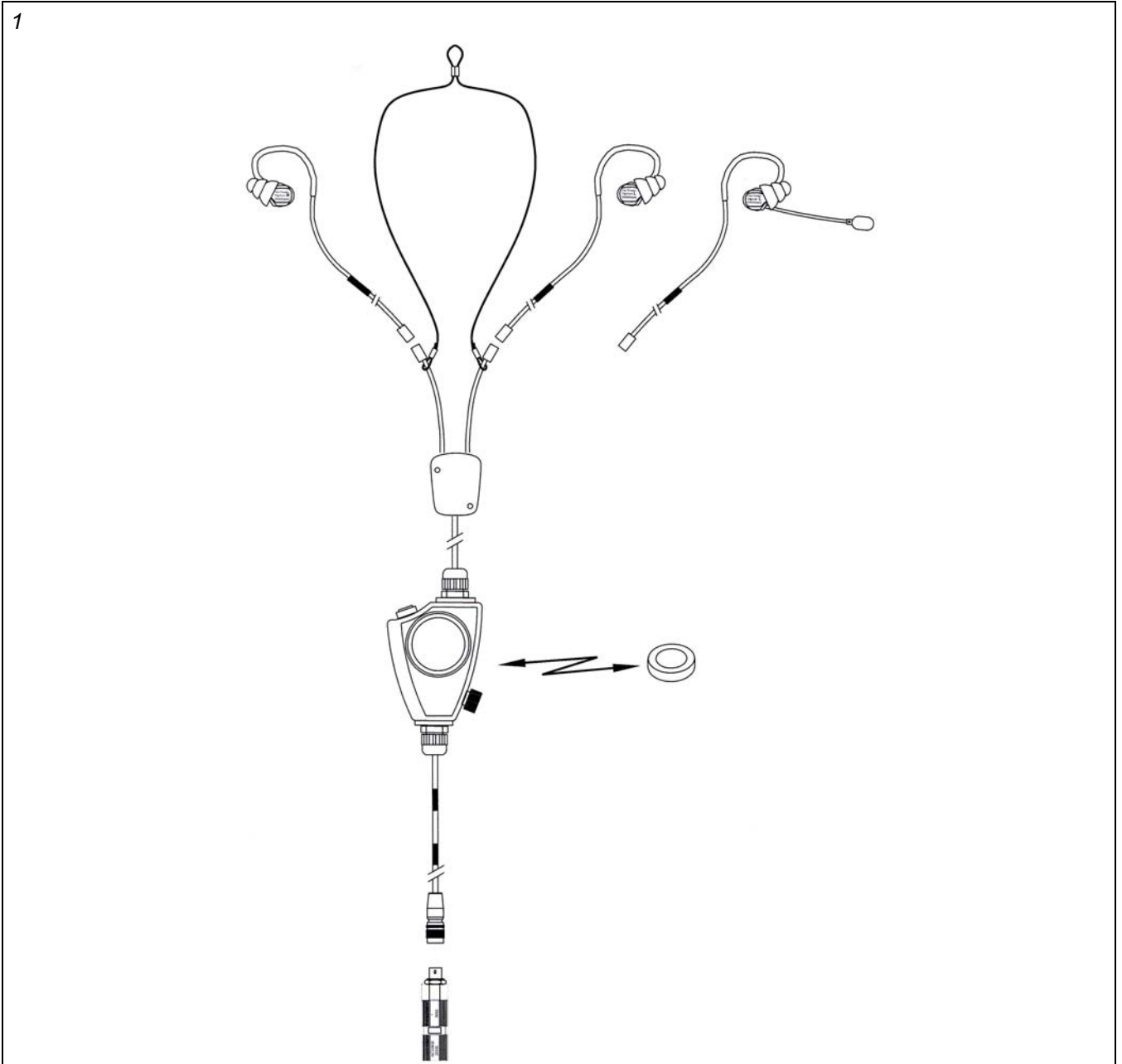

Content

1.	Important safety instructions	3
2.	Description	4
2.1	Ear-microphone	6
2.2	Earphone with gooseneck-microphone.....	6
2.3	Universal three level ear plug	7
2.4	Individually ear mould	7
2.5	PTT-button.....	11
2.6	CT-Wireless-PTT (example).....	12
3.	Commissioning and operation	14
4.	Safekeeping – storage	15
5.	Maintenance	15
5.1	Visual inspections	15
5.2	Cleaning.....	15
5.3	Changing the protective cover of the gooseneck microphone.....	16
6.	Consumable parts + accessory.....	16

1. Important safety instructions



For the use of the device notice the national safety and accident prevention regulations and the following safety instructions shown in italics in this instruction manual.

- *Before using CeoTronics products read completely the appropriate operating instructions. If in doubt, ask our technical staff.*
- *Use only CeoTronics products without damage and wear.*
- *If repair work of any kind needs to be done to CeoTronics products, arrange for it to be performed only by the company CeoTronics or by a specialized workshop that is authorized by CeoTronics. In all other cases our warranty and liability for the product shall lapse.*
- *Do not store CeoTronics products outside or in damp ambient conditions. At all times keep them clean, dry and at normal air humidity. CeoTronics products must not be stored in areas with a temperature of over +80° C (+176° F), e.g. in the summertime on the parcel shelf of a car. If not stated otherwise, the following temperature ranges are allowed for CeoTronics products: -10 to +55° C (+14 to +131° F) for operation, -40 to +80° C (-40 to +176° F) for storage.*
- *Do not immerse a CeoTronics product into water, if it is not expressly specified for this purpose.*
- *When using CeoTronics products that are equipped with connection leads ensure that the latter do not get caught up in operational machinery or wheels!*
- *CeoTronics products that are not intrinsically safe (explosion-proof) and therefore have no special explosion-proof designation must never be operated in potentially explosive environments (e.g. when refuelling cars, aircraft etc.). Devices that are not explosion-proof can unintentionally trigger off explosions in such areas!*
- *Connect CeoTronics accessories to a device or disconnect them from a device only when the device is switched off. In the case of intrinsically safe products (explosion-proof) this must always take place outside of the potentially explosive area. Otherwise the consequence could be an unintentional explosion!*
- ***Please note that in some radios very loud signalling beeps could be present already in the moment of switching the radio on. There are various types of radios generating a series of signals in different loudness levels. It may be necessary to adjust the volume of the signalling beeps separately. These beeps could damage your hearing if they are set too high. Therefore, adjust signalling beeps to a convenient level as desired before starting to use CeoTronics accessories. Follow the instructions of the radio manufacturer's operating manual to adjust the signalling beeps.***
- *For safety reasons reception volumes in excess of 85 dB (A) are possible with a whole series of CeoTronics products. However, these can be regulated by the user. After switching on the communication system, set the reception volume to approx. 1/2 the available loudness volume and then test the audible volume, e.g. by opening the squelch on the radio set.*
Do not set the volume any higher than is necessary. A very high volume setting can lead to damaged hearing, particularly if it is continuous. For high volumes or noise levels wear additional ear plugs. If in doubt, ask your safety officer or company doctor.
- *Do not leave CeoTronics products lying around loose in cars, e.g. on the parcel shelf. Stow these products in a suitable, safe place in the car so that they do not present a danger to you or to other occupants of the car, if emergency braking is effected.*
- *Keep CeoTronics products out of the reach of children and any other persons who are not familiar with the handling and operation thereof.*
- *Packaging materials, e.g. filling materials and plastic bags are not toys and have to be kept out of the reach of children. There is a risk of children ingesting them and choking!*
- *Safe operation requires clean devices. Ensure that the devices (microphones, connectors etc.) are clean and in good condition at all times.*
- *CeoTronics products may only be used for the specific application envisaged.*

-
- *Should equipment, supplied by CeoTronics, be definitely put out of service you may return it to CeoTronics. We ensure recycling and/or disposal of outdated equipment in compliance with the applicable environment protection law.*
 - *Keep these operating instructions for later use.*

2. Description

General

The CT-ClipCom Digital is a binaural communication system for use with radio equipment. The PTT buttons (PTT=push-to-talk) of the system are used to transmit PTT commands to the radio unit or similar communication systems.

The following two system configurations are available:

CT-ClipCom Digital ear microphone consisting of one ear microphones plus one earphone, a PTT transmit button, and an optional CT-Wireless-PTT

CT-ClipCom Digital gooseneck microphone consisting of one earphone plus one earphone with gooseneck microphone, a PTT transmit button, and an optional CT-Wireless-PTT

The earphones/ear microphones are electro-acoustic transducers, used either as microphones (for transmitting) or earphones (for receiving), worn in the ear with ear plugs.

Optional can be worn the ear microphone in the ear with individually formed ear moulds.

The system is equipped with ambient sound reception (ASR) for both sides.

The employment of ASR makes a level-dependant sound absorption possible.

Power is provided by the radio unit.

System overview (examples)

2 CT-ClipCom Digital gooseneck microphone

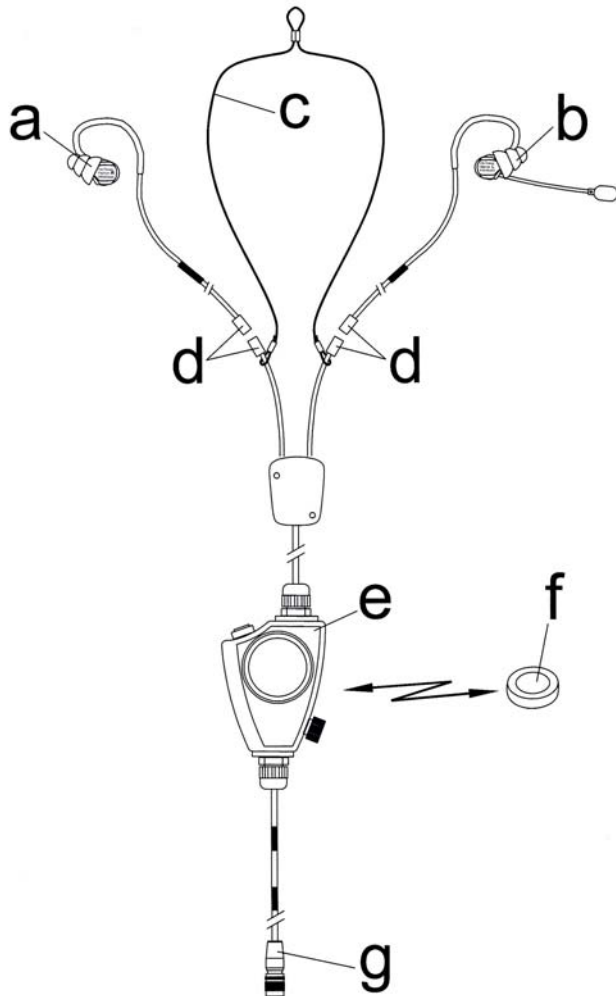

3 ClipCom Digital ear-microphone

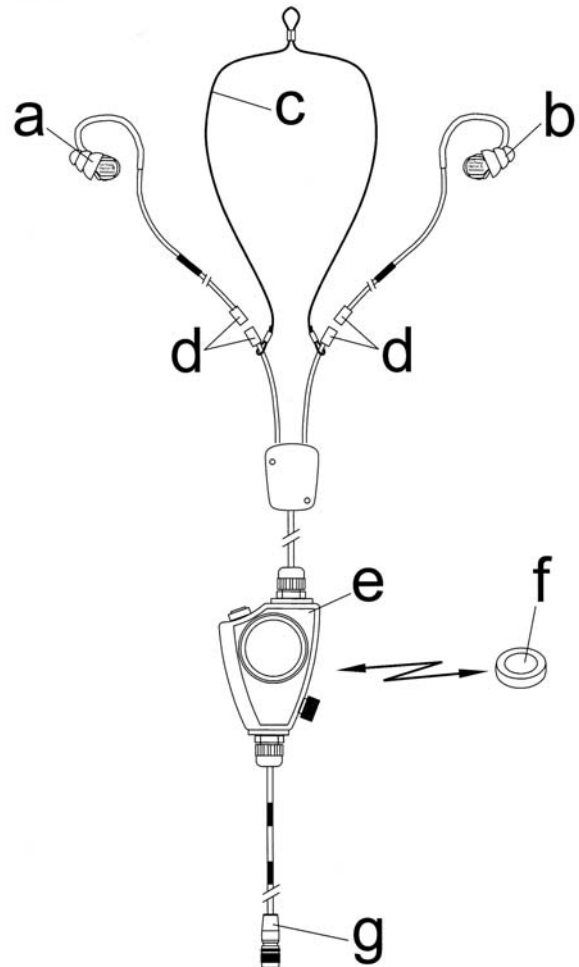

a ear-phone	a ear-microphone
b ear-phone with gooseneck microphone	b ear-phone
c neck band	c neck band
d connector	d connector
e PTT-button	d PTT-button
f CT-Wireless-PTT (example)	e CT-Wireless-PTT (example)
g connection plug for radio (example – dependant on the radio)	g connection plug for radio (example – dependant on the radio)

2.1 Ear-microphone

The ear-microphone is at the right side and is identified by a red marking. The earphone is at the left side and is identified by a blue marking. The casing of the ear-microphone contains the ASR-microphone (figure 4/d) in addition to the ear-microphone itself (figure 4/c). For using the ear-microphone it is just clipped onto the ear plug (see 2.3).

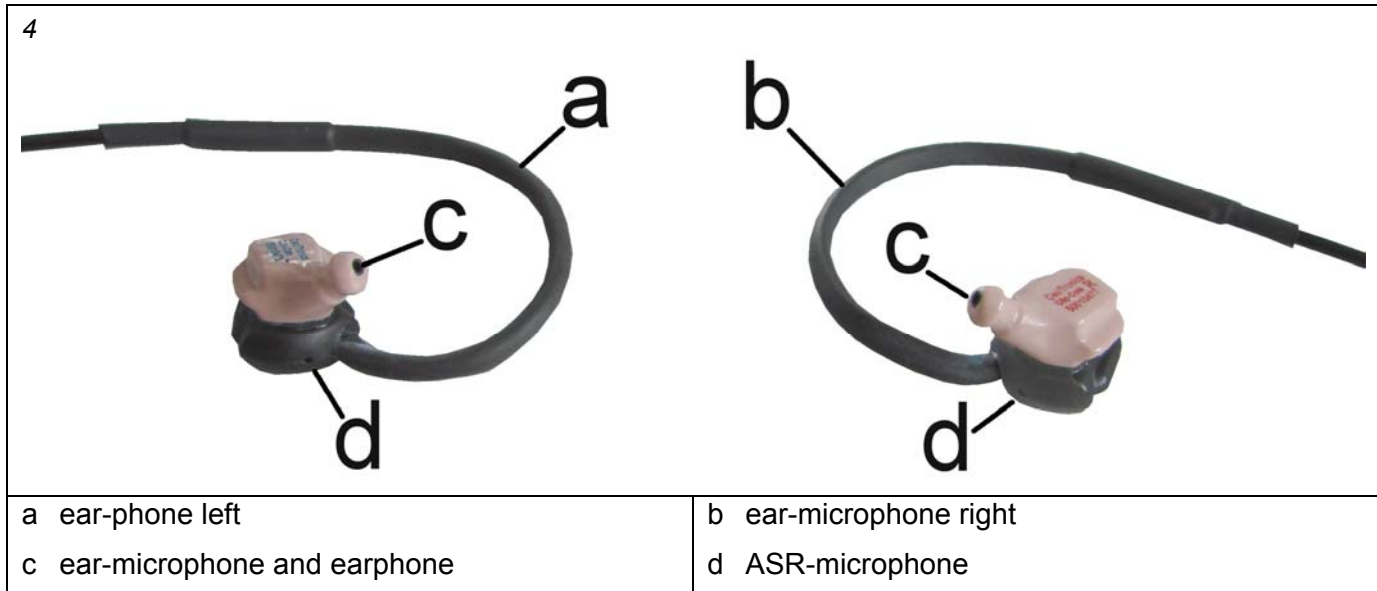

2.2 Earphone with gooseneck-microphone

The earphone with gooseneck microphone is available for the left ear only. Gooseneck microphone with protective cover (figure 5/c) and ASR-microphone (figure 5/b) are attached to the earphone. For using the earphone it is clipped onto an individual ear plug.

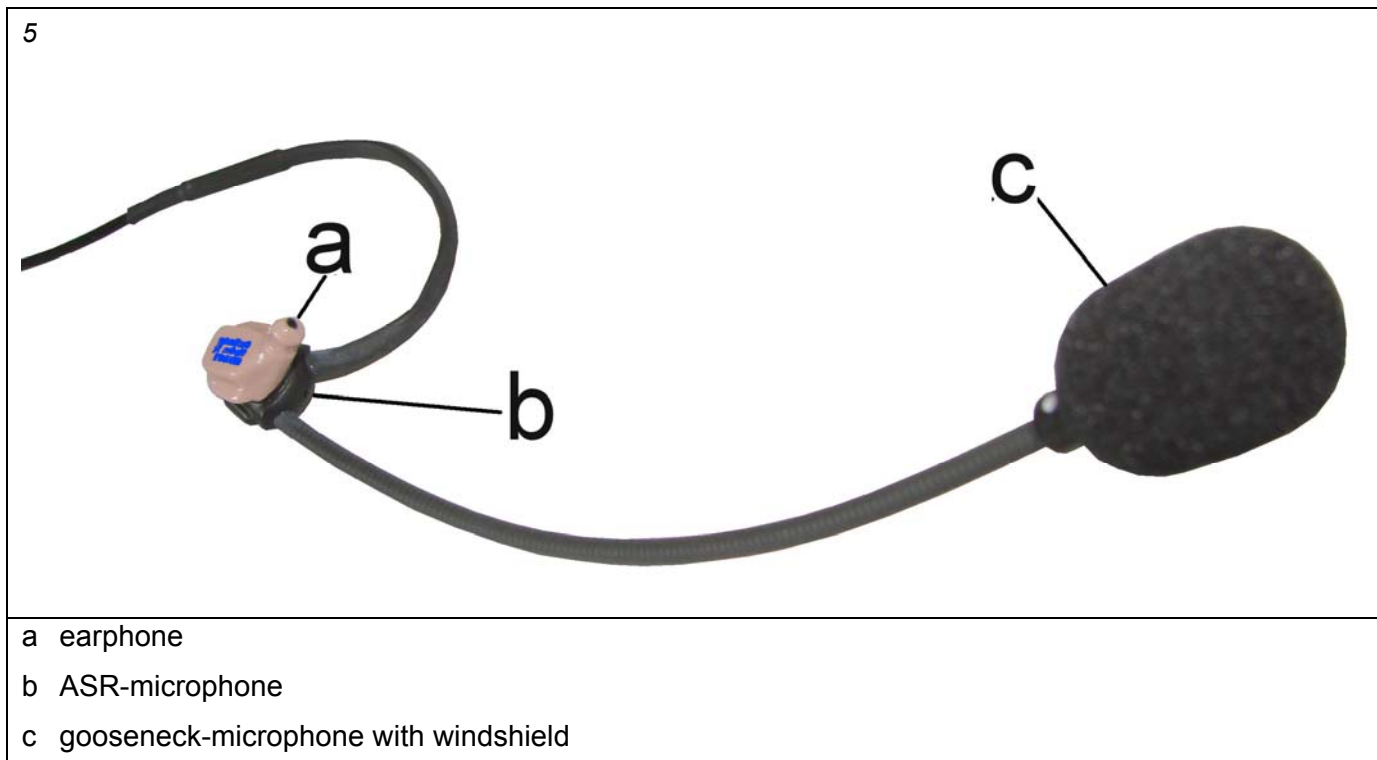

2.3 Universal three level ear plug

The ear plug is used for adaptation of the ear microphone / earphone to the auditory canal. It is »pushed« with a rotating motion onto the ear microphone / earphone (Fig. 6). If no perfect seat in the ear is achievable, because the standard ear plug is too large, the largest lamella ring can be cut off with a sharp knife (figure 7-9).

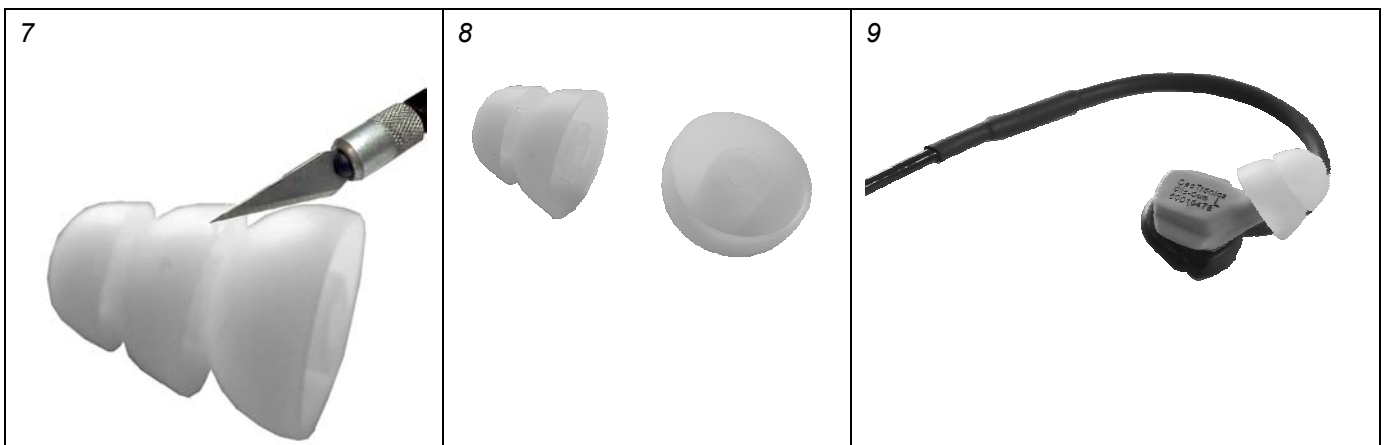
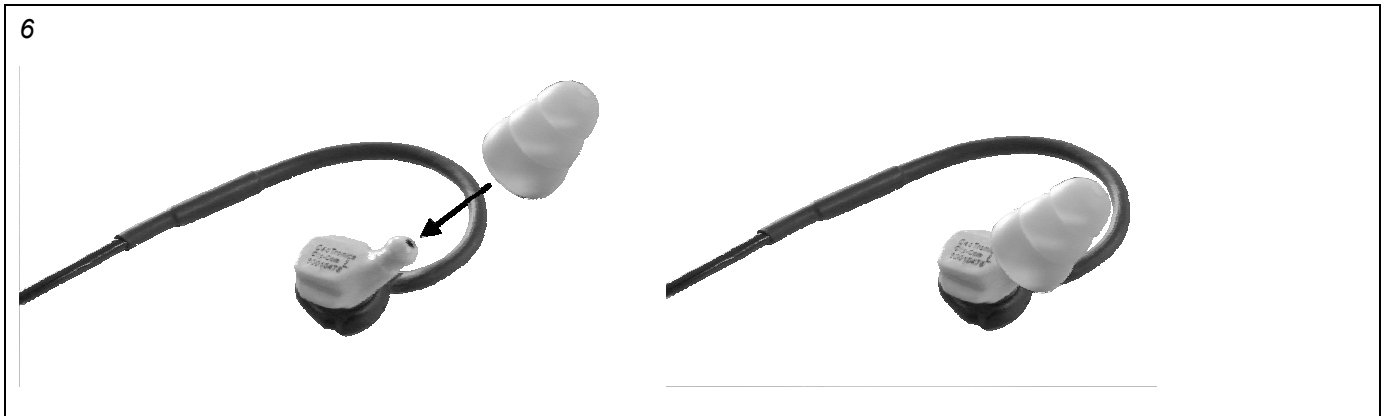

2.4 Individually ear mould

This ear mould (example Fig. 10) ensures maximum wear comfort and transmission quality. Only when carry the individually ear moulds the highest possible protection of the ears is ensured. It is moulded according to an individual impression of the auditory canal either for wearing in the right ear or in the left ear. For different personal needs different variants are available. The earphone is “clipped” in the ear mould. The ear mould is worn in the ear.

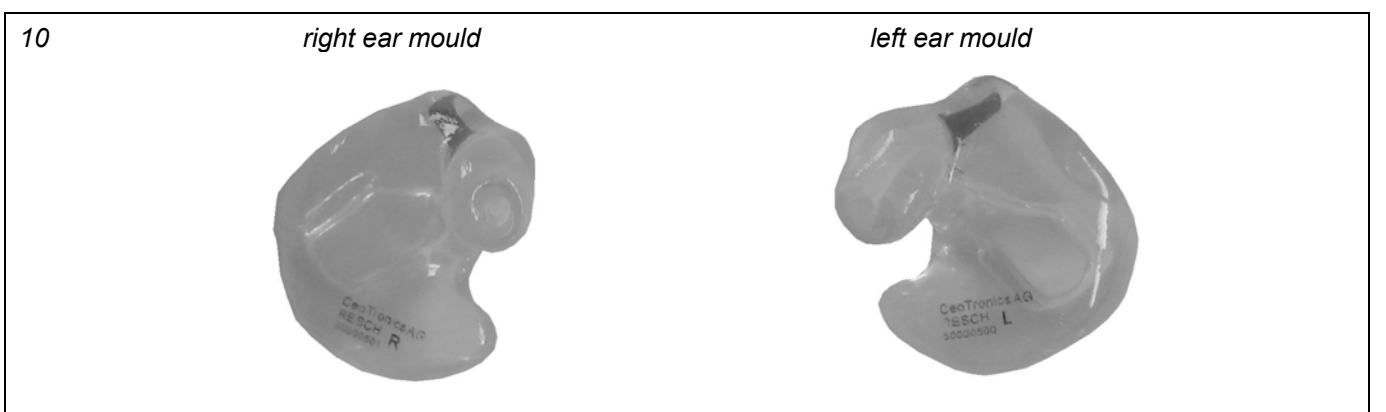

Installing the ear phone in the ear mould

➔ PLEASE NOTE

Earphone and ear mould for the right ear have a red ink marking, the ear microphone and ear mould for the left ear are marked with blue ink.

- Take the ear mould in one and the ear microphone in the other hand. The sound channels of ear mould and ear microphone must be looking into the same direction (figure 11).
- Push the ear microphone in direction of the arrow into the ear mould until it “engages”. Figure 12 shows the ear microphone inserted in the ear mould.

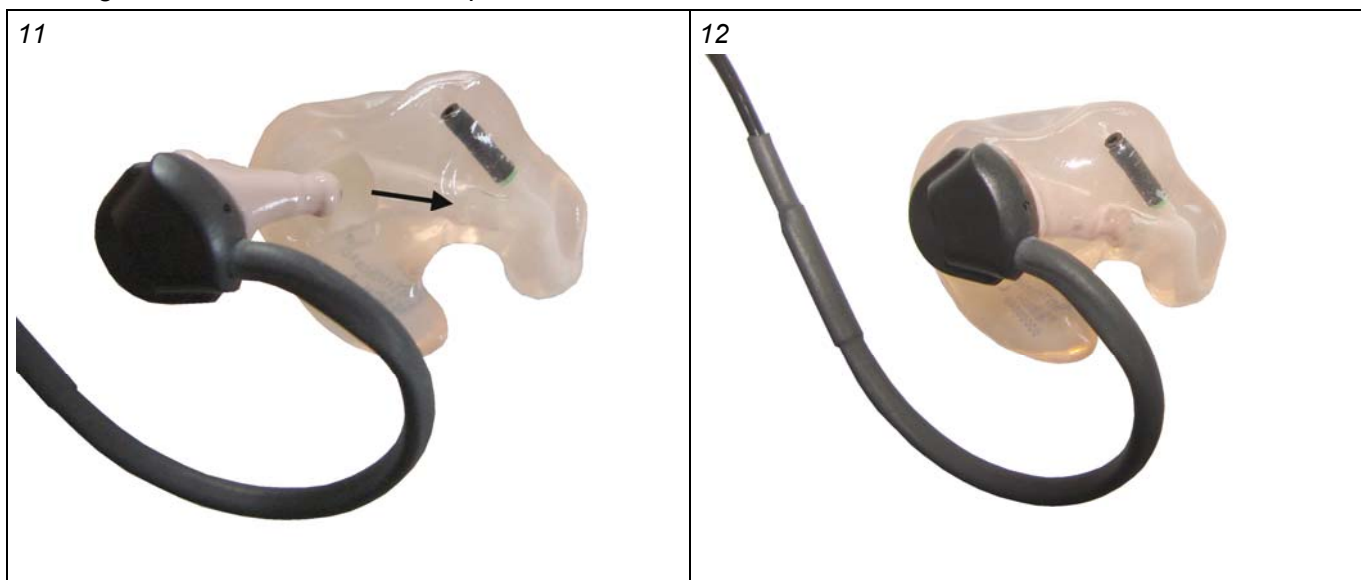

Removing the earphone from the ear mould

- Take the ear mould in one hand and press the two ends of it against each other (figure 13) until ear microphone “disengages” from the ear mould.

⚠ ATTENTION!

Never extract the earphone from the ear mould by pulling the cable.

- Now hold the earphone with the other hand and pull it out of the ear mould.



2.4.1 Information regarding hearing protection (Only for operation with individually ear moulds with filter SKLD26)

Manufacturer: CeoTronics AG
Type designations: CT-ClipCom digital BoomMike and/or EarMike with p/n 6015068, 6015069 & options

2.4.1.1 Fitting accuracy of ear moulds

The CT-ClipCom digital communication system combined with personalised ear moulds / earpieces is considered a personalised hearing protector which has been tested and certified within the scope of the EC-type approval as personal protection equipment in the meaning of the European Directive 89/686/EG.

The sound insulating effect of a personalised ear mould depends principally on the proper accurate fit and the personal ergonomics of the user.

For this reason, CeoTronics recommends to check the fitting accuracy of personalised ear moulds by making acoustic measurements. Only this way it is possible to assure an appropriate sound insulating effect of your ear mould.

For this purpose CeoTronics has developed a special testing system.

A sound insulation measurement made by this testing system, duly documented by a test certificate, proves that the personalised ear moulds provide sufficient sound insulation.

Please note that this is a qualitative measurement and therefore the results must not necessarily coincide with statistically ascertained values of subjective sound insulation experienced by 16 test persons in the type approval test, as these are two different measuring methods.

Experience shows that that actual personal sound insulation values are slightly higher than the values measured by the CeoTronics testing system. As the lower limits are used the minimum sound insulation values of the EN 352-2 Standard.

In rare individual cases it is possible that no satisfactory sound insulation can be achieved in spite of maximum care exercised in the process of taking impressions and manufacturing the ear moulds.

In such cases our earplugs can be used, however no specific certification is available for use together with the CT-ClipCom digital communication system.

Wear of ear moulds varies individually; we recommend regular examination by measuring the moulds with the CeoTronics testing system or replacement of your personalised ear mould after 2 years.

Kindly contact our customer consultants in case you want to test your personalised ear mould or clarify any further questions regarding this subject.

2.4.1.2 Conformity to Standards

This hearing protection complies with the requirements of the European Standard EN 352-2 and EN 352-7:2003. It has been designed, manufactured, and tested according to the state of the art and in compliance with the DIN EN ISO 9001 Standard.

Marking:

14 Example



2.4.1.3 General technical data

Mass

BoomMike: $\approx 17\text{g}$

EarMike: $\approx 6\text{g}$

2.4.1.4 Sound insulation values with personalised ear moulds and SKLD26 filter

Please take note that the certified ear moulds / earpieces and earplugs are able to function as hearing protection only if they are worn on both sides and both are covered by a CT-ClipCom system. For the one-sided version the sound insulation values of the table below may be used, provided that the other ear is covered with a sufficient sound insulation.

Sound insulation of the personalised ear moulds and SKLD26 filter

H = 27 dB	SNR = 26 dB
M = 22 dB	
L = 21 dB	

Result			
Frequency [Hz]	Sound insulation [dB]	Standard deviation [dB]	APV [dB]
63	26,0	6,5	19,5
125	28,0	8,7	19,3
250	26,2	5,8	20,4
500	25,4	5,3	20,1
1000	25,6	4,7	20,9
2000	32,5	5,1	27,4
4000	35,6	3,5	32,1
8000	32,4	6,0	26,4

Level dependence with personalised ear moulds and SKLD26 filter

Criterion level

BoomMike

EarMike

H = 102,3 dB	H = 98,8 dB
M = 102 dB	M = 99 dB
L = 109,6 dB	L = 111,8 dB

The APV, H, M, L, and SNR values have been established according to EN ISO 4869-2 with parameter $\alpha=1$.

2.4.1.5 Output sound pressure level

The CT-ClipCom digital is equipped with a communication system. The user should verify proper functioning before using it. In case distortions or breakdowns are detected, the user is requested to follow the manufacturer's maintenance recommendations.

WARNING! The output sound pressure level of the communication system of the "CT-ClipCom digital" could exceed the daily limit value.

2.5 PTT-button

The PTT button is provided with connecting cable and plug for connection to a radio unit via a radio adapter.

The PTT button and the CT-Wireless-PTT have equality of function. The CT-Wireless-PTT must be subscribed to the PTT button.

15

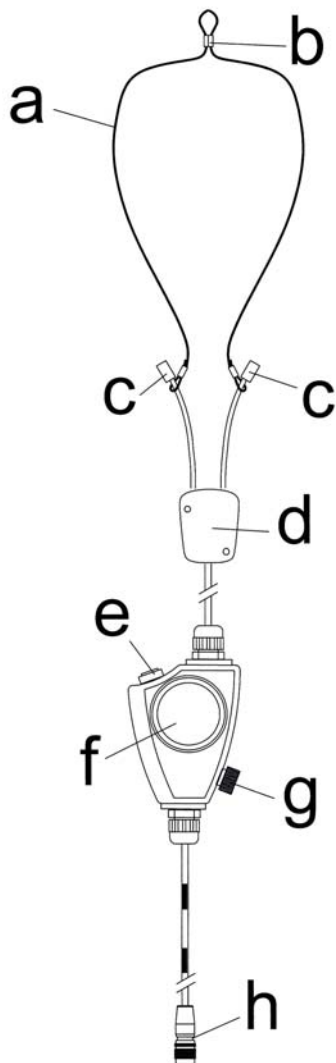

- a Neck band
- b Size regulation
- c Connector
- d Connection box with fixation clip at the back
- e Volume control for the ASR-microphone
- f PTT-button
- g Volume control for the ear phone
- h connection plug for radio (example – dependant on the radio)

2.5.1 Ambient sound reception

Ambient sound ASR Ambient Sound Reception is picked up via the microphones in the ClipCom earphones. The volume can be conveniently adjusted with the help of key (figure 14/e). Adjustment is made in 4 steps.

Initial position: 0dB (normal hearing)

1st keying +6dB

2nd keying OFF

3rd keying -6dB

4th keying Reset to 0dB (initial position)

2.6 CT-Wireless-PTT (example)

This transmit button is a radio key to transmit PTT commands to a connected radio device. The CT-Wireless-PTT and the wire-bound PTT transmit button (see chapter 2.5) have equality of function. The CT-Wireless-PTT must be subscribed to the wire-bound transmit button. A battery provides power to the CT-Wireless-PTT. For safety reasons, keying of the CT-Wireless-PTT is limited to 30 seconds. Different CT-Wireless-PTT can be used.

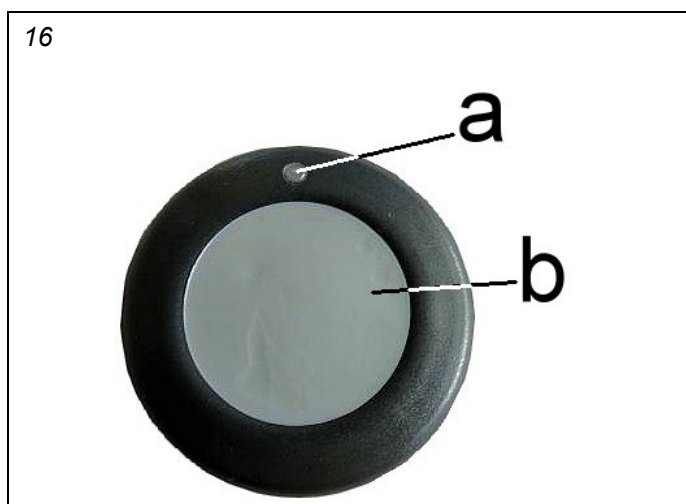

- a LED – illuminates when the PTT button is pressed
b PTT button

2.6.1 Subscription of the CT-Wireless-PTT to the PTT button

1. Switch OFF the radio unit connected to the PTT button if it is in switched-on state
2. Insert the CT-ClipCom ear microphones/earphones in the ears
3. Press the two keys (figure 14/e, f) of the PTT button
 - Keep the keys depressed and switch the radio ON
 - Continue keeping the two keys depressed until you hear a short beep in the RH CT-ClipCom ear microphone/earphone
 - After it, let the two keys go
4. Press the PTT key (figure 14/f) of the wire-bound PTT transmit button 3 times
 - After it you hear the following tone sequence – beep-beep-beep....beep-beep-beep...beep-
5. Now press the PTT key on the CT-Wireless-PTT until you hear a long tone lasting 4 seconds. Then let the key go. Now you hear again the previous sequence of beeps.
6. Now, press the PTT key of the PTT button once. After it, you hear no more beeps.
7. Then switch the communication system OFF.

➔ PLEASE NOTE

As long as the PTT button is in programming mode, all other functions are disabled. To exit the programming mode and enter into operating mode, the radio device must be switched OFF for at least 2 seconds and then switched ON again.

In case of loss of a CT-Wireless-PTT, we recommend deleting it from the receiver.

2.6.2 Deleting one CT-Wireless-PTT from the memory of a PTT button

1. Switch OFF the radio unit connected to the PTT button if it is in switched-on state
2. Insert the CT-ClipCom ear microphones/earphones in the ears
3. Press the two keys (figure 14/e, f) of the PTT button
 - Keep the keys depressed and switch the radio ON
 - Continue keeping the two keys depressed until you hear a short beep in the RH CT-ClipCom ear microphone/earphone
 - After it, let the two keys go
4. Press the PTT key (figure 14/f) of the wire-bound PTT transmit button once and keep it depressed for at least 2 seconds. The deletion mode is now activated.
 - In deletion mode you hear a very fast tone sequenceThe deletion mode can be aborted by briefly pressing again the PTT key.
5. Now, press the PTT key for the CT-Wireless-PTT you want to delete and keep it depressed until you hear a long tone lasting 4 seconds. The transmitter code is now deleted and you may release the key.

2.6.3 Deleting all CT-Wireless-PTTs from the memory of PTT button

1. Switch OFF the radio unit connected to the PTT button if it is in switched-on state
2. Insert the CT-ClipCom ear microphones/earphones into the ears
3. Press the two keys (figure 14/e, f) of the PTT button
 - Keep the keys depressed and switch the radio ON
 - Continue keeping the two keys depressed until you hear a short beep in the RH CT-ClipCom ear microphone/earphone
 - After it, let the two keys go
4. Press the PTT key (figure 14/f) of the PTT button once and keep it depressed for at least 2 seconds. The deletion mode is now activated.
 - In deletion mode you hear a very fast tone sequence.The deletion mode can be aborted by briefly pressing again the PTT key.
5. Press now once more the PTT key of the wire-bound PTT transmit button for more than 2 seconds. As soon as you hear a long tone lasting 4 seconds, all transmitter codes are deleted.

2.6.4 Changing the battery of the CT-Wireless-PTT

1. Open the battery compartment on the back of the CT-Wireless-PTT using the opening tool by a swift left turn.

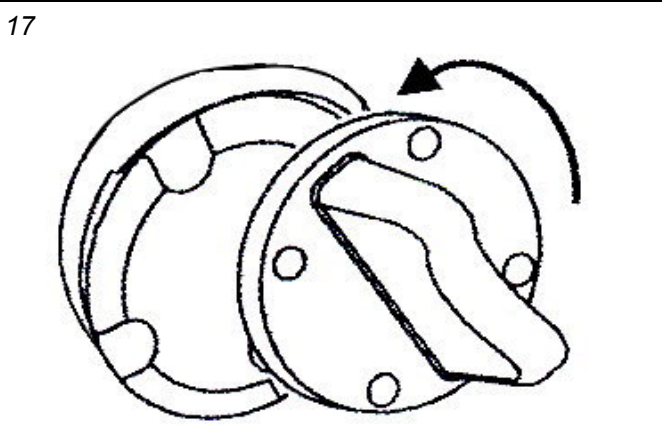

2. Cautiously remove the circuit board from the housing. Change the battery minding correct polarity; lettering must be visible. Use 3-V batteries type CR2032 only

⚠ ATTENTION
Mind correct polarity!

⚠ ATTENTION
Batteries may not be disposed off in the domestic waste!

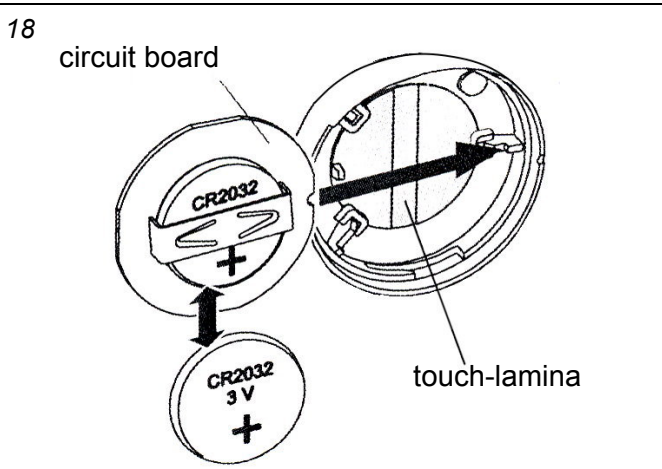

3. When closing the CT-Wireless-PTT put a new sealing ring under the lid, if necessary. Place the lid notches into the guides in the housing and lock the lid with a right turn. Make sure lid and housing have a tight fit.

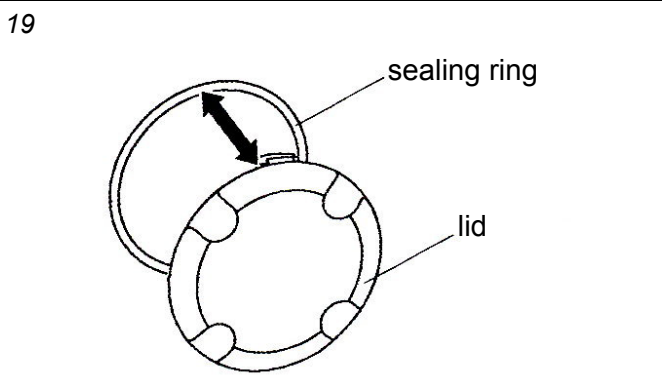

3. Commissioning and operation

- a. Connect the ear microphones/earphones to the PTT button (see figure 2 or 3).
- b. Place the neck band with the PTT button around your neck. Adjust the size of the neck band.
- c. Inserting the ear microphone/earphone: Place the ear hanger of the ear microphones /earphones behind the ear. Insert the ear microphone / earphone into your ear. Adjust the seat of the ear hanger, if necessary.

Please note for the use of individually ear moulds (not in scope of delivery): Insert the ear mould into your ear with a quarter turn towards the back of the head until it has a snug fit.

Caution

Wear the hearing protection in areas with noise without interruption.

Wear the hearing protection only like is described in this operation instructions.

Check the device periodically for signs of fractures, cracks and wear.

During disregard the protective effect of the hearing protection can be seriously impaired.

This hearing protection should not be carried if the danger exists that the cord gets caught or drag along during carrying.

By a mechanical hit against the ear hanger can result harmful noise level.

- d. Connect the PTT button via the plug and the radio adaptor to the radio. Switch the radio on and adjust at the radio the desired volume of reception for the ear microphone.

CAUTION!

Before each start of operation control the volume of reception and adjust it, if necessary. Very loud signals could damage your hearing.

Observe the manufacturer's operating instruction for the radio device.

- e. Transmitting and receiving: For transmitting (speaking) press the PTT button or the CT-Wireless-PTT and keep it depressed. For safety reasons, keying of the CT-Wireless-PTT is limited to 30 seconds. The radio is switched to transmission. You can speak as long as you keep the transmit button depressed. Let the transmit button go in order to switch the radio back to standby/receiving (hearing).

CT-ClipCom Digital ear microphone

The DNR electronics (Digital Noise Reduction) filter and eliminate ambient noise from the voice signal.

Radio messages are heard on both sides. In case a PTT transmit button is actuated the ear microphone in the right ear switches from earphone to microphone operation. Consequently, the ambient sound reception (ASR) of this ear microphone is not active.

CT-ClipCom Digital gooseneck microphone

The noise cancelling gooseneck microphone works without DNR function.

During activation of the PTT button, ambient sound reception is active on both sides.

4. Safekeeping – storage

After use, keep the cleaned devices in a clean and dry place at normal room temperature and at normal relative air humidity.

5. Maintenance

5.1 Visual inspections

Check the CT-ClipCom Digital and particularly the cables and connectors periodically for signs of fractures, cracks and wear. Check ear moulds and earphones/ear microphones after every use for pollution.

Pollution can be the cause for skin irritation and malfunction.

5.2 Cleaning

ATTENTION!

When cleaning, make sure that no moisture penetrates inside the device. Do not use any solvents (e.g. benzine, alcohol, sterilizing agents, etc.). After cleaning, keep earphones/ear microphones unpacked until completely dry.

Obstructed sound channels of ear moulds and ear plugs cause poor communication in transmitting (speaking) and reception (hearing). For periodical cleaning of components we recommend special cleaning tissues (see chapter 6).

Clean the contacts of connectors with a commonly available contact cleaning agent.

Ear moulds and Earphones

Obstructed sound channels of ear moulds and earphones cause poor reception. For regular cleaning (after every use) we recommend the use of special antiseptic cleaning tissues (see item 7), an appropriate cleaning spray, or soft clean cloths and pure water with some dishwashing liquid.

Do not use solvents for cleaning purposes.

For a basic cleaning of ear moulds we recommend a cleaning bath once a week (effervescent tablets; e.g. Detax Smarttabs) or ultrasonic bath.

5.3 Changing the protective cover of the gooseneck microphone

Check the protective foam cover periodically for pollution, wear and deformation and replace it, if necessary. It can be easily pulled off the microphone.

6. Consumable parts + accessory

Designation	Unit	Part No.
Cleaning tissues	pack of 100	6098293
Protective microphone cover	pack of 10	50 022 03
Lithium button cell CR 2032		9801781
Set for changing battery with battery		9800906

<p>Germany and International Sales</p> <p>CeoTronics AG Adam-Opel-Str. 6 63322 Rödermark Tel. +49 6074 8751-0 Fax +49 6074 8751-676 E-Mail sales@ceotronics.com</p> <div style="display: flex; justify-content: space-around; align-items: center;">   </div> <p style="text-align: center; font-size: small;">DIN EN ISO 9001:2000 Certificate No. 01 100 004023 Certificate No. 01 102 004023 Directive 94/9/EC (ATEX) Certificate No. 01 220 004023</p>		
<p>USA/Canada/Mexico</p> <p>CeoTronics, Inc. 300 Southport Circle, Suite 103 Virginia Beach, Virginia 23452 Tel. +1 757 549-6220 Fax +1 757 549-6240 E-Mail sales@ceotronicsusa.com</p>	<p>France</p> <p>CeoTronics Sarl Bât. Delta T Z.A. du Tuboeuf Allée des Pleus 77170 Brie Comte Robert Tel. +33 1 60183300 Fax +33 1 60286060 E-Mail ventes@ceotronics.fr</p>	<p>Spain</p> <p>CeoTronics S.L. C/Ciudad de Frias 7 y 9 Nave 19 28021 Madrid Tel. +34 91 4608250 51 Fax +34 91 4603193 E-Mail ventas@ceotronics.es</p>
<p>Switzerland</p> <p>CeoTronics AG Grundstr. 16 6343 Rotkreuz Tel. +41 41 7905838 Fax +41 41 7905839 E-Mail info@ceotronics.ch</p>	<p>Poland</p> <p>CeoTronics Sp. z o.o. ul. Stonecza 15 91-491 Łódź (Polska) Tel. +48 42 6553311 Fax +48 42 6552288 E-Mail biuro@ceotronics.pl</p>	<p>Germany and International Sales</p> <p>CT-Video GmbH Gewerbegebiet Rothenschirmbach 9 06295 Lutherstadt Eisleben Tel. +49 34776 6149-0 Fax +49 34776 6149-11 E-Mail ctv.info@ceotronics.com</p>