

333LM SAMPLE INSTRUCTIONS

CHAMBERLAIN®

LiftMaster®

PROFESSIONAL

MODEL 333LM 3-BUTTON REMOTE CONTROL TRANSMITTER 333 OWNER'S MANUAL

The green push button is recommended for use with a garage door opener. The other push buttons can be used to operate another opener and/or light control product.

The 333LM 3-Button Remote Control Transmitter can also be used with a 423LM 3-channel receiver and a 3-button door control to operate a commercial door opener in open, close, and stop mode (as explained on side 2).

To match or change the code in the transmitter

Locate the code switches in both the new and the original transmitters. The new transmitter's code switches can be found by sliding the battery compartment cover back. Place transmitters side by side as shown (Figure 1) and set switches in all transmitters to matching positions (+, 0, -). Use a pen or screwdriver to slide the code switches.

Figure 1

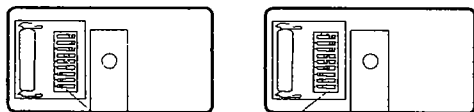

Match code switches (2-9) between old transmitter and new transmitter (Code switch #1 on the 3-button remote control is dormant)

NOTE: Code switch #1 on the 3-button transmitter is dormant, when used with a single-button transmitter. Set code switch #1, in the single-button transmitter, to match the push button selected on the 3-button transmitter (Figure 2).

Figure 2

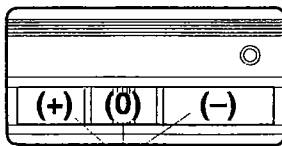

Push Buttons

Replacement Parts

Remote case housing (circuit board not included)	41A3580-4
Visor clip	.29C128
12V battery	.10A14

WARNING

To prevent possible SERIOUS INJURY or DEATH from a moving gate or garage door:

- ALWAYS keep remote controls out of reach of children. NEVER permit children to operate, or play with remote control transmitters.
- Activate gate or door ONLY when it can be seen clearly, is properly adjusted, and there are no obstructions to door travel.
- ALWAYS keep gate or garage door in sight until completely closed. NEVER permit anyone to cross path of moving gate or door.

Programming the opener

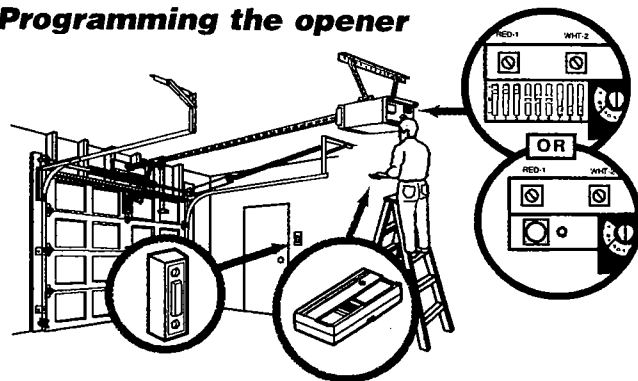

If your unit has a "Learn" button:

1. Press and release the "learn" button located on the back panel of the motor unit. The learn indicator light will glow steadily for 30 seconds.
2. Within the 30 second window, press and hold the button on the hand-held remote.
3. The unit will either activate or the opener light bulb will blink signifying it has learned the code.

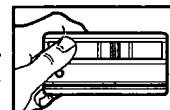
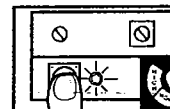

If your unit has code switches:

1. Using a step ladder climb up to the back of your motor unit. Check the code switch settings on the back of the motor unit.
2. Use a pen or screw driver to set the code switches on the back of the transmitter to match the code switches on the back of the motor unit.
3. Once the code switches have been set push the transmitter button to activate your unit.

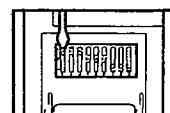
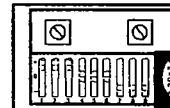

⚠ WARNING

Install the control station and receiver where the door is visible, but away from the door and its hardware. When a receiver is used to activate a commercial door opener, a reversing edge **MUST** be installed on the bottom of the door. Failure to install a reversing edge under these circumstances may result in **SERIOUS INJURY** or **DEATH** to persons trapped beneath the door.

To use the transmitter with a 3-channel receiver and 3-button door control to operate a commercial door opener

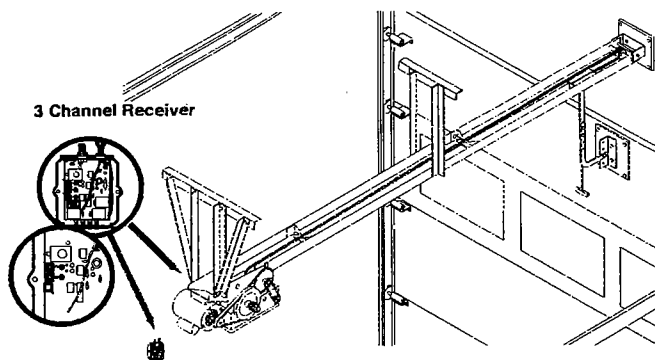

1. Use a screwdriver to pry open the receiver cover (see illustration).

NOTE: The slide switch is factory set to the N.C. position (otherwise the opener will not operate). Verify this setting.

2. Select a remote control push button to STOP the opener. (RED is recommended.) Press and hold the selected remote push button.

3. Then press and release the "learn" button labeled "A" on the receiver. The adjacent indicator light will FLASH. Release the remote push button.

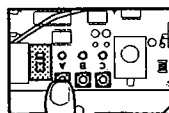
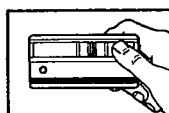
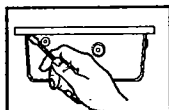

Repeat the procedure above with the yellow remote push button and receiver "learn" button "B" to program the CLOSE operation; and again with the green remote push button and receiver "learn" button "C" to program the OPEN function of the opener.

Return the front cover to the receiver.

(For this application, code switch settings need not be changed.)

NOTE: If a remote control push button is not pressed within 30 seconds, the indicator light adjacent to the selected "learn" button will turn OFF. In that case, repeat the programming.

Replacing the transmitter battery

⚠ WARNING

To prevent possible **SERIOUS INJURY** or **DEATH**:

- NEVER allow small children near batteries.
- If battery is swallowed, immediately notify doctor.

The 12 volt battery should produce power for 1 year. To replace the battery, slide the battery compartment cover.

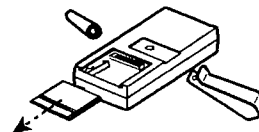

Dispose of old batteries properly.

NOTICE: To comply with FCC and or Industry Canada rules (IC), adjustment or modifications of this receiver and/or transmitter are prohibited, except for changing the code setting or replacing the battery. THERE ARE NO OTHER USER SERVICEABLE PARTS.

Tested to Comply with FCC Standards FOR HOME OR OFFICE USE. Operation is subject to the following two conditions: (1) this device may not cause harmful interference, and (2) this device must accept any interference received, including interference that may cause undesired operation.

FOR SERVICE DIAL OUR TOLL-FREE NUMBER:

1-800-528-2817