

# COMMERCIAL 24VDC HIGH TRAFFIC OVERHEAD DOOR AND GATE OPERATOR WITH BATTERY BACKUP INSTALLATION MANUAL

# Model HCTDCU

**HCTDCU**  
Motor Unit

**HCT08**  
8 Foot Rail

**HCT10**  
10 Foot Rail

**HCT12**  
12 Foot Rail



OPERATOR  
REQUIRES  
LIFTMASTER EXTERNAL  
MONITORED ENTRAPMENT  
PROTECTION DEVICE

- THIS PRODUCT IS TO BE INSTALLED AND SERVICED BY A TRAINED TECHNICIAN ONLY.
- This model is for use on vehicular passage gates or commercial doors ONLY and not intended for use on pedestrian passage gates.
- Install the operator at least 8 feet (2.4 m) above the floor.
- This model is intended for use in Class II, III and IV vehicular trolley gate or commercial door applications.
- Visit [LiftMaster.com](http://LiftMaster.com) to locate a professional installing dealer in your area.
- This gate/door operator is compatible with MyQ® and Security+ 2.0® accessories.

Register your operator to receive updates and offers from LiftMaster

Take a photo of the camera icon including the points (⊙).

Send it in by texting the photo to 71403 (US) or visit [www.liftmaster.photo](http://www.liftmaster.photo) (Global)



LiftMaster  
845 Larch Avenue  
Elmhurst, IL 60126-1196

# LiftMaster®

## ELITE SERIES®

# TABLE OF CONTENTS

<b>SAFETY</b>	<b>2</b>	<b>OPERATION</b>	<b>23</b>
SAFETY SYMBOL AND SIGNAL WORD REVIEW .....	2	GATE/DOOR OPERATOR SETUP EXAMPLES.....	23
USAGE CLASS .....	3	CONTROL BOARD OVERVIEW.....	24
UL325 ENTRAPMENT PROTECTION REQUIREMENTS.....	3	RESET BUTTON .....	25
SAFETY INSTALLATION INFORMATION.....	4	OPERATOR ALARM .....	25
GATE CONSTRUCTION INFORMATION.....	5	ADJUSTABLE OPEN SPEED.....	25
<b>INTRODUCTION</b>	<b>6</b>	REMOTE CONTROL .....	25
CARTON INVENTORY .....	6	MANUAL DISCONNECT .....	26
OPERATOR SPECIFICATIONS.....	7	<b>ACCESSORY WIRING</b>	<b>27</b>
OVERVIEW OF TYPICAL INSTALLATION.....	8	EXTERNAL CONTROL DEVICES.....	27
<b>INSTALLATION</b>	<b>9</b>	EXTERNAL RESET BUTTON.....	27
IMPORTANT SAFETY INFORMATION .....	9	MISCELLANEOUS WIRING .....	28
CONNECT RAIL TO OPERATOR.....	10	<b>EXPANSION BOARD</b>	<b>29</b>
INSTALL VENTED PLUG .....	11	EXPANSION BOARD OVERVIEW .....	29
DETERMINE LOCATION FOR OPERATOR.....	11	AUXILIARY RELAYS .....	30
MOUNT THE OPERATOR .....	12	WIRING ACCESSORIES TO THE EXPANSION BOARD.....	31
INSTALL ENTRAPMENT PROTECTION.....	13	<b>MAINTENANCE</b>	<b>32</b>
<b>WIRING</b>	<b>15</b>	IMPORTANT SAFETY INFORMATION .....	32
POWER WIRING .....	15	MAINTENANCE CHART.....	32
CONNECT BATTERIES .....	16	BATTERIES .....	32
<b>ADJUSTMENT</b>	<b>17</b>	<b>TROUBLESHOOTING</b>	<b>33</b>
LIMIT AND FORCE ADJUSTMENT .....	17	DIAGNOSTIC CODES .....	33
OBSTRUCTION TEST .....	18	CONTROL BOARD LEDS.....	36
<b>OPERATOR OVERVIEW</b>	<b>19</b>	TROUBLESHOOTING CHART.....	37
<b>PROGRAMMING</b>	<b>20</b>	<b>WIRING DIAGRAM</b>	<b>40</b>
REMOTE CONTROLS (NOT PROVIDED) .....	20	<b>REPAIR PARTS</b>	<b>41</b>
LIFTMASTER INTERNET GATEWAY (NOT PROVIDED) .....	21	<b>ACCESSORIES</b>	<b>42</b>
ERASE ALL CODES.....	21	<b>WARRANTY</b>	<b>44</b>
ERASE LIMITS.....	21		
TO REMOVE AND ERASE MONITORED ENTRAPMENT PROTECTION DEVICES.....	21		
LIMIT SETUP WITH A REMOTE CONTROL.....	22		

## SAFETY

### SAFETY SYMBOL AND SIGNAL WORD REVIEW

When you see these Safety Symbols and Signal Words on the following pages, they will alert you to the possibility of **Serious Injury or Death** if you do not comply with the warnings that accompany them. The hazard may come from something mechanical or from electric shock. Read the warnings carefully.

When you see this Signal Word on the following pages, it will alert you to the possibility of damage to your gate/door and/or the gate/door operator if you do not comply with the cautionary statements that accompany it. Read them carefully.

#### IMPORTANT NOTE:

- *BEFORE attempting to install, operate or maintain the operator, you must read and fully understand this manual and follow all safety instructions.*
- *Operator intended to be installed on a properly balanced gate/door only. Make sure gate/door is properly balanced before installing.*
- *DO NOT attempt repair or service of your operator unless you are an Authorized Service Technician.*

 **WARNING**

**MECHANICAL**

 **WARNING**

**ELECTRICAL**

**CAUTION**

# SAFETY

## USAGE CLASS

### CLASS I – RESIDENTIAL VEHICULAR GATE OPERATOR

A vehicular gate operator (or system) intended for use in garages or parking areas associated with a residence of one-to four single families.



### CLASS II – COMMERCIAL/GENERAL ACCESS VEHICULAR GATE OPERATOR

A vehicular gate operator (or system) intended for use in a commercial location or building such as a multi-family housing unit (five or more single family units), hotel, garages, retail store, or other buildings accessible by or servicing the general public.

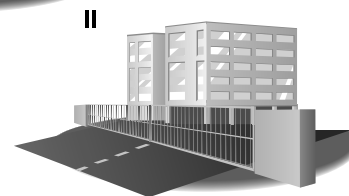

### CLASS III – INDUSTRIAL/LIMITED ACCESS VEHICULAR GATE OPERATOR

A vehicular gate operator (or system) intended for use in an industrial location or building such as a factory or loading dock area or other locations not accessible by or intended to service the general public.

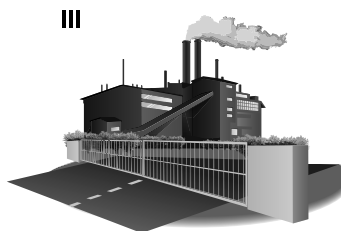

### CLASS IV– RESTRICTED ACCESS VEHICULAR GATE OPERATOR

A vehicular gate operator (or system) intended for use in a guarded industrial location or building such as an airport security area or other restricted access locations not servicing the general public, in which unauthorized access is prevented via supervision by security personnel.

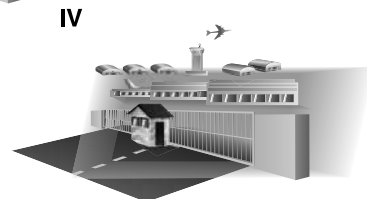

## UL325 ENTRAPMENT PROTECTION REQUIREMENTS

This vehicular gate/door operator must be installed with at least two independent entrapment protection means as specified in the table below.

HORIZONTAL SLIDE AND SWING GATE OPERATOR	
GATE OPERATOR ENTRAPMENT PROTECTION TYPES	
Type A	Inherent (built into the operator) entrapment protection system
Type B1	Non-contact sensors such as photoelectric sensors
Type B2	Contact sensors such as edge sensors

The same type of device shall not be used for both entrapment protection means. Use of a single device to cover both the opening and closing directions is in accordance with the requirement; however, a single device is not required to cover both directions. This operator is provided with Type A. The installer is required to install additional entrapment protection devices in each entrapment zone.

## IMPORTANT SAFETY INFORMATION

### ⚠ WARNING

- To reduce the risk of SEVERE INJURY or DEATH:
- READ AND FOLLOW ALL INSTRUCTIONS.
  - NEVER let children operate or play with gate/door controls. Keep remote controls away from children.
  - ALWAYS keep people and objects away from the gate/door. NO ONE SHOULD CROSS THE PATH OF THE MOVING GATE/DOOR.
  - Test the gate/door operator monthly. The gate/door MUST reverse on contact with a rigid object or reverse when an object activates the non-contact sensors. After adjusting the force or the limit of travel, retest the gate/door operator. Failure to adjust and retest the operator properly can increase the risk of severe INJURY or DEATH.
  - Use the emergency release ONLY when the gate/door is closed. Use caution when using this release when the gate/door is open. Weak or broken springs may cause the gate/door to fall rapidly, causing severe INJURY or DEATH.
  - KEEP GATES/DOORS PROPERLY OPERATING AND BALANCED. Read the gate/door manufacturer's owner's manual. An improperly operating or balanced gate/door could cause severe INJURY or DEATH. Have a qualified service person make repairs to gate/door hardware. Have trained gate/door systems technician make repairs to cables, spring assemblies, and other hardware.
  - The entrance is for vehicles ONLY. Pedestrians MUST use separate entrance.
  - SAVE THESE INSTRUCTIONS.

# SAFETY

## SAFETY INSTALLATION INFORMATION

1. Vehicular gate systems provide convenience and security. Gate systems are comprised of many component parts. The gate operator is only one component. Each gate system is specifically designed for an individual application.
2. Gate operating system designers, installers and users must take into account the possible hazards associated with each individual application. Improperly designed, installed or maintained systems can create risks for the user as well as the bystander. Gate systems design and installation must reduce public exposure to potential hazards.
3. A gate operator can create high levels of force in its function as a component part of a gate system. Therefore, safety features must be incorporated into every design. Specific safety features include:
  - Edges Sensors (contact)
  - Guards for Exposed Rollers
  - Photoelectric Sensors
  - Screen Mesh
  - Vertical Posts
  - Instructional and Precautionary Signage
4. Install the gate operator only when:
  - a. The operator is appropriate for the construction and the usage class of the gate.
  - b. All openings of a horizontal slide gate are guarded or screened from the bottom of the gate to a minimum of 6 feet (1.8 m) above the ground to prevent a 2-1/4 inches (6 cm) diameter sphere from passing through the openings anywhere in the gate, and in that portion of the adjacent fence that the gate covers in the open position.
  - c. All exposed pinch points are eliminated or guarded, and guarding is supplied for exposed rollers.
5. The operator is intended for installation only on gates used for vehicles. Pedestrians must be supplied with a separate access opening. The pedestrian access opening shall be designed to promote pedestrian usage. Locate the gate such that persons will not come in contact with the vehicular gate during the entire path of travel of the vehicular gate.
6. The gate must be installed in a location so that enough clearance is supplied between the gate and adjacent structures when opening and closing to reduce the risk of entrapment. Swinging gates shall not open into public access areas.
7. The gate must be properly installed and work freely in both directions prior to the installation of the gate operator.
8. Controls intended for user activation must be located at least 6 feet (1.8 m) away from any moving part of the gate and where the user is prevented from reaching over, under, around or through the gate to operate the controls. Outdoor or easily accessible controls shall have a security feature to prevent unauthorized use. Exception: Emergency access controls only accessible by authorized personnel (e.g. fire, police) may be placed at any location in the line-of-sight of the gate.
9. The Stop and/or Reset (if provided separately) must be located in the line-of-sight of the gate. Activation of the reset control shall not cause the operator to start.
10. A minimum of two (2) WARNING SIGNS shall be installed, one on each side of the gate where easily visible.
11. For a gate operator utilizing a non-contact sensor:
  - a. Reference owner's manual regarding placement of non-contact sensor for each type of application. See *Install Entrapment Protection* section.
  - b. Care shall be exercised to reduce the risk of nuisance tripping, such as when a vehicle trips the sensor while the gate is still moving.
  - c. One or more non-contact sensors shall be located where the risk of entrapment or obstruction exists, such as the perimeter reachable by a moving gate or barrier.
12. For a gate operator utilizing a contact sensor such as an edge sensor:
  - a. One or more contact sensors shall be located where the risk of entrapment or obstruction exists, such as at the leading edge, trailing edge and post mounted both inside and outside of a vehicular horizontal slide gate.
  - b. A hard wired contact sensor shall be located and its wiring arranged so the communication between the sensor and the gate operator is not subject to mechanical damage.
  - c. A wireless device such as one that transmits radio frequency (RF) signals to the gate operator for entrapment protection functions shall be located where the transmission of the signals are not obstructed or impeded by building structures, natural landscaping or similar obstruction. A wireless device shall function under the intended end-use conditions.
  - d. One or more contact sensors shall be located on the inside and outside leading edge of a swing gate. Additionally, if the bottom edge of a swing gate is greater than 6 inches (152 mm) above the ground at any point in its arc of travel, one or more contact sensors shall be located on the bottom edge.
  - e. One or more contact sensors shall be located at the bottom edge of a vertical barrier (arm).
  - f. One or more contact sensors shall be located at the bottom edge of a vehicular vertical lift gate.
  - g. One or more contact sensors shall be located at the pinch point of a vehicular vertical pivot gate.

## GATE CONSTRUCTION INFORMATION

Vehicular gates should be installed in accordance with ASTM F2200: Standard Specification for Automated Vehicular Gate Construction. For a copy, contact ASTM directly at 610-832-9585 or [www.astm.org](http://www.astm.org).

### 1. GENERAL REQUIREMENTS

- 1.1 Gates shall be constructed in accordance with the provisions given for the appropriate gate type listed, refer to ASTM F2200 for additional gate types.
- 1.2 Gates shall be designed, constructed and installed to not fall over more than 45 degrees from the vertical plane, when a gate is detached from the supporting hardware.
- 1.3 Gates shall have smooth bottom edges, with vertical bottom edged protrusions not exceeding 0.50 inches (12.7 mm) when other than the exceptions listed in ASTM F2200.
- 1.4 The minimum height for barbed tape shall not be less than 8 feet (2.44 m) above grade and for barbed wire shall not be less than 6 feet (1.83 m) above grade.
- 1.5 An existing gate latch shall be disabled when a manually operated gate is retrofitted with a powered gate operator.
- 1.6 A gate latch shall not be installed on an automatically operated gate.
- 1.7 Protrusions shall not be permitted on any gate, refer to ASTM F2200 for Exceptions.
- 1.8 Gates shall be designed, constructed and installed such that their movement shall not be initiated by gravity when an automatic operator is disconnected, in accordance with the following.
  - 1.8.1 Vehicular horizontal slide gate. Shall not result in continuous, unimpeded movement in either lineal direction of its travel.
  - 1.8.2 Vehicular horizontal swing gate. Shall not result in continuous, unimpeded movement in either direction along the arc of its path of travel.
- 1.9 For pedestrian access in the vicinity of an automated vehicular gate, a separate pedestrian gate shall be provided. The pedestrian gate shall be installed in a location such that a pedestrian shall not come in contact with a moving vehicular access gate. A pedestrian gate shall not be incorporated into an automated vehicular gate panel.

### 2. SPECIFIC APPLICATIONS

- 2.1 Any non-automated gate that is to be automated shall be upgraded to conform to the provisions of this specification.
- 2.2 This specification shall not apply to gates generally used for pedestrian access and to vehicular gates not to be automated.
- 2.3 Any existing automated gate, when the operator requires replacement, shall be upgraded to conform to the provisions of this specification in effect at that time.

### 3. VEHICULAR VERTICAL LIFT GATES

- 3.1 The following provisions shall apply to Class I, Class II and Class III vehicular vertical lift gates:
  - 3.1.1 All openings shall be designed, guarded or screened to prevent a 4 in. (102 mm) diameter sphere from passing through the openings anywhere in the gate.
  - 3.1.2 A gap, measured in the horizontal plane parallel to the roadway, between a fixed stationary object nearest the roadway (such as a gate support post) and the gate frame when the gate is in either the fully open position or the fully closed position, shall not exceed 4 in. (102 mm).  
Exception: All other fixed stationary objects greater than 16 in. (406 mm) from the gate frame shall not be required to comply with this section.
  - 3.1.3 Horizontal and vertical framing members of a gate shall be smooth, and shall not include horizontal protrusions other than gate hardware.

- 3.1.4 A positive stop shall be required to limit travel to the designed fully open position.
- 3.2 Class IV vehicular vertical lift gates shall be designed, constructed and installed in accordance with security related parameters specific to the application in question.

### 4. VEHICULAR VERTICAL PIVOT GATES

- 4.1 The following provisions shall apply to Class I, Class II, and Class III vehicular vertical pivot gates:
  - 4.1.1 All areas of the moving gate panel from the bottom of the gate to the top of the gate or a minimum of 72 in. (1.83 m) above grade, whichever is less, that pass by a fixed stationary object, and in the area of the adjacent fence that the gate covers during the travel of the gate, shall be designed, guarded or screened to prevent a 2 1/4 in. (57 mm) diameter sphere from passing through such areas.
  - 4.1.2 A gap, measured in the horizontal plane parallel to the roadway, between a fixed stationary object nearest the roadway (such as a gate support post) and the gate frame when the gate is in either the fully open position or the fully closed position, shall not exceed 4 in. (102 mm).  
Exception: All other fixed stationary objects greater than 16 in. (406 mm) from the gate frame shall not be required to comply with this section.
  - 4.1.3 Horizontal and vertical framing members of a gate shall be smooth, and shall not include protrusions other than gate hardware.
  - 4.1.4 All gates shall be designed with sufficient lateral stability to assure that the gate will enter a receiver guide.
- 4.2 Class IV vehicular vertical pivot gates shall be designed, constructed and installed in accordance with security related parameters specific to the application in question.

### 5. VEHICULAR OVERHEAD PIVOT GATES

- 5.1 The following provisions shall apply to Class I, Class II and Class III vehicular overhead pivot gates:
  - 5.1.1 All weight bearing exposed rollers 8 ft (2.44 m), or less, above grade shall be guarded or covered.
  - 5.1.2 All openings shall be designed, guarded or screened to prevent a 4 in. (102 mm) diameter sphere from passing through the openings anywhere in the gate.
  - 5.1.3 A gap, measured in the horizontal plane parallel to the roadway, between a fixed stationary object nearest the roadway (such as a gate support post) and the gate frame when the gate is in either the fully open position or the fully closed position, shall not exceed 2 1/4 in. (57 mm).  
Exception: All other fixed stationary objects greater than 16 in. (406 mm) from the gate frame shall not be required to comply with this section.
  - 5.1.4 Horizontal and vertical framing members of a gate shall be smooth, and shall not include protrusions other than gate hardware.
  - 5.1.5 Where required, positive stops shall limit travel to the designed fully open position, or the designed fully closed position, or both.
  - 5.1.6 All jamb materials, track materials and related hardware shall be designed to support the weight of the gate at any position of the gate.
- 5.2 Class IV vehicular overhead pivot gates shall be designed, constructed and installed in accordance with security related parameters specific to the application in question.

# INTRODUCTION

## CARTON INVENTORY

**NOT SHOWN:** Documentation Packet

HCTDCU Motor Unit

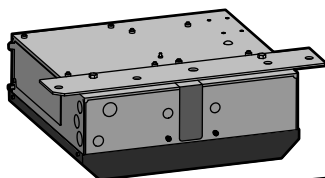

Warning Signs (2) and Warranty Card

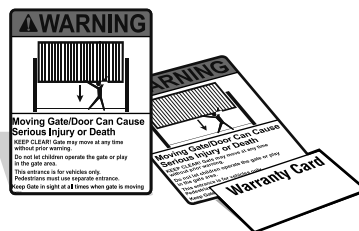

Battery 12 Vdc 7AH (2)

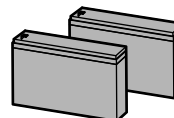

8 Foot (2.4 m) Rail HCT08  
10 Foot (3.1 m) Rail HCT10  
12 Foot (3.7 m) Rail HCT12

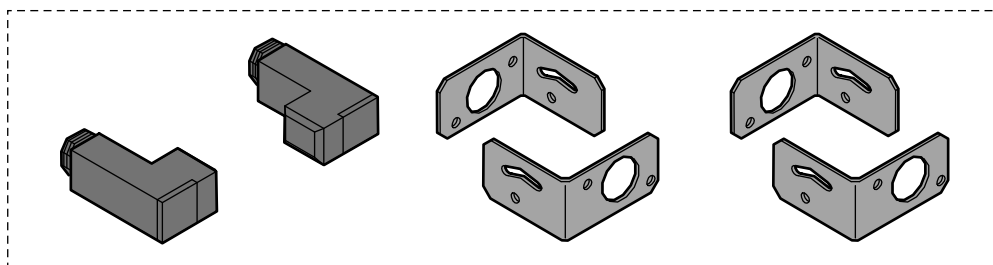
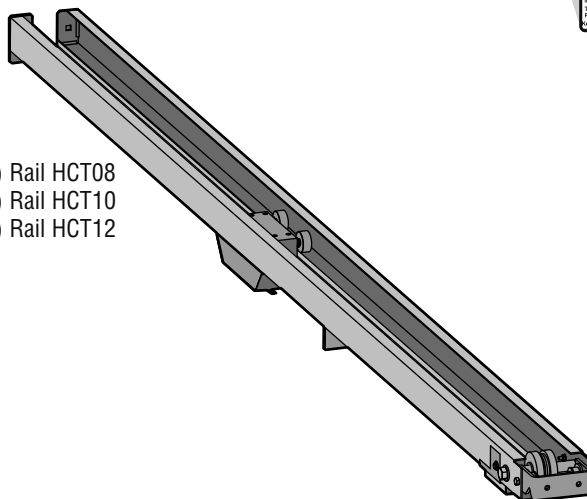

LiftMaster Photoelectric Sensors (CPSUN4G)

# INTRODUCTION

## OPERATOR SPECIFICATIONS

<b>Usage Classification</b>	Class II, III, and IV
<b>Main AC Supply</b>	120 Vac, 4 Amps <b>OR</b> 240 Vac, 2 Amps
<b>System Operating Voltage</b>	24 Vdc Transformer Run / Battery Backup
<b>Accessory Power</b>	24 Vdc, 500mA max. for ON + SW (switched)
<b>Solar Power Max</b>	24 Vdc at 60 watts max.
<b>Variable Operating Lengths</b>	8 foot (2.4 m) gate - 11.75 foot (3.6 m) operator length 10 foot (3.1 m) gate - 13.75 foot (4.2 m) operator length 12 foot (3.7 m) gate - 15.75 foot (4.8 m) operator length
<b>Maximum Gate/Door Weight</b>	700 lbs. (317.5 kg)
<b>Maximum Gate/Door Width (sectional and one-piece)</b>	22 ft. (6.7 m)
<b>Travel Speed</b>	Default - 8 inches (20.3 cm) per second Fast - 11 inches (27.9 cm) per second (open speed only)
<b>Maximum Daily Cycle Rate</b>	Continuous
<b>Maximum Duty Cycle</b>	Continuous
<b>Operating Temperature</b>	-20°C to 60°C (-4°F to 140°F)
<b>Expansion Board</b>	Provided
<b>Inherent Entrapment Protection (Type A)</b>	Dual - RPM and Current Sense
<b>External Entrapment Protection (Type B1 and/or Type B2)</b>	3 inputs per board - any combination of up to 3 photoelectric sensors and up to 2 edge sensors

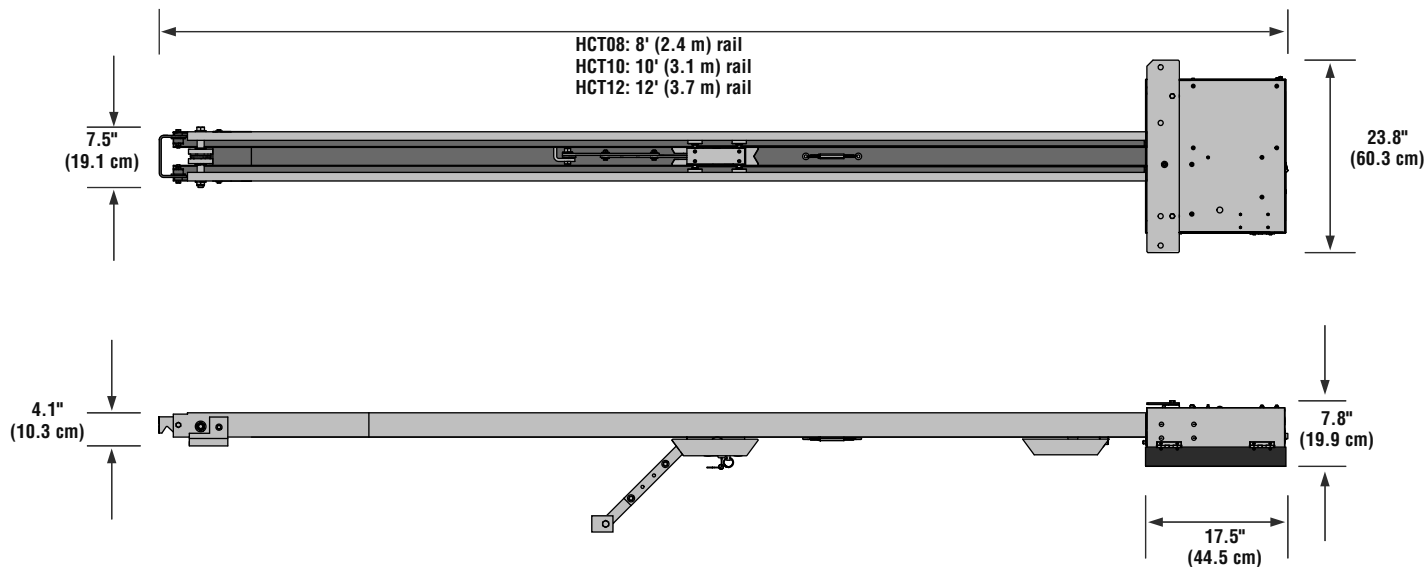

# INTRODUCTION

## OVERVIEW OF TYPICAL INSTALLATION

Check the national and local building codes **BEFORE** installation.

**NOTE:** One or more contact or non-contact external monitored entrapment protection systems shall be located where the risk of entrapment or obstruction exists at either the opening or closing direction. Care shall be exercised to reduce the risk of nuisance tripping, such as when a vehicle trips the sensor while the gate/door is still moving.

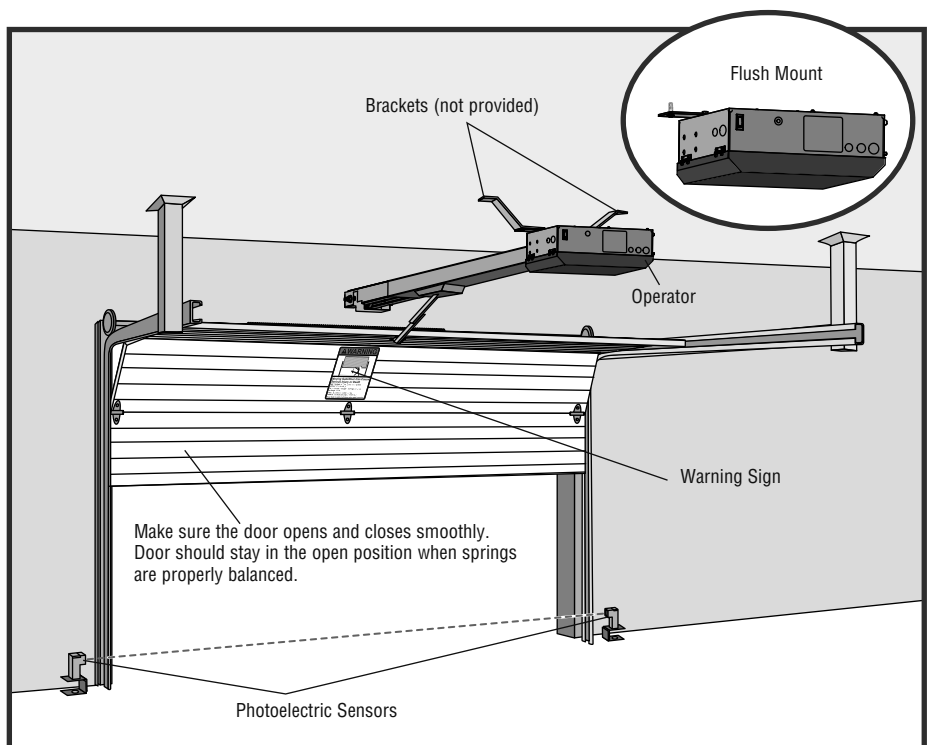
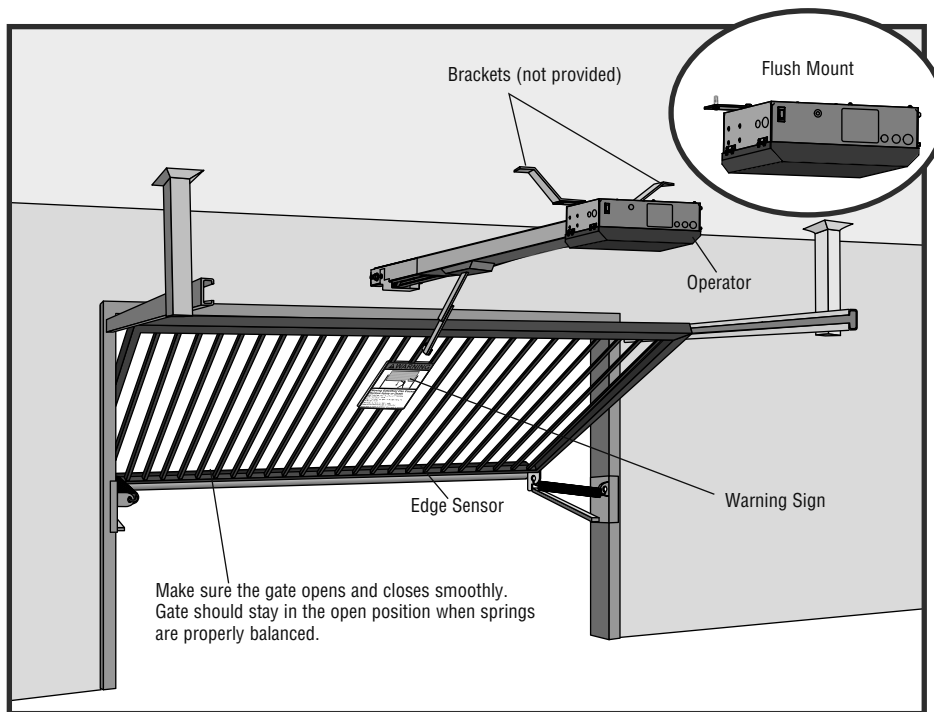



## INSTALLATION

### IMPORTANT INSTALLATION INSTRUCTIONS

#### WARNING

#### TO REDUCE THE RISK OF SEVERE INJURY OR DEATH:

1. READ AND FOLLOW ALL INSTRUCTIONS.
2. Install operator ONLY on properly balanced and lubricated gate/door. An improperly balanced gate/door may NOT reverse when required and could result in SEVERE INJURY or DEATH.
3. ALL repairs to cables, spring assemblies and other hardware MUST be made by a trained systems technician BEFORE installing operator.
4. Disable ALL locks and remove ALL ropes connected to gate/door BEFORE installing operator to avoid entanglement.
5. Install gate/door operator 8 feet (2.4 m) or more above floor.
6. NEVER connect operator to power source until instructed to do so.
7. Any openings shall be designed, guarded or screened to prevent a 2 1/4" (5.7 cm) diameter sphere from passing through the openings anywhere in the gate/door.
8. Entrapment protection devices MUST be installed to protect anyone who may come near a moving gate/door. Upon completion of installation, test entrapment protection device.
9. Too much force on gate/door will interfere with proper operation of safety reversal system.
  - NEVER increase force beyond minimum amount required to move gate/door.
  - NEVER use force adjustments to compensate for a binding or sticking gate/door.
  - If one control (force or travel limits) is adjusted, the other control may also need adjustment.
10. Install control station:
  - within sight of the gate/door
  - out of reach of children at minimum height of 5 feet (1.5 m)
  - at least 6 feet (1.8 m) from the gate/door or ANY moving part of the gate/door
11. This operator is intended for vehicular use ONLY. To prevent INJURY to pedestrians, a separate pedestrian access should be supplied, visible from the gate/door. Locate the pedestrian access where there is NOT a chance of INJURY at ANY point during full movement of the gate/door.
12. Install Warning signs on EACH side of gate/door in PLAIN VIEW. Install one Warning Sign next to the control station. Permanently secure each Warning sign in a suitable manner using fastening holes.
13. **SAVE THESE INSTRUCTIONS.**

#### CAUTION

- ALWAYS wear protective gloves and eye protection when changing the battery or working around the battery compartment.
- NEVER wear watches, rings or loose clothing while installing or servicing operator. They could be caught in gate/door or operator mechanisms.

# INSTALLATION

## STEP 1

### CONNECT RAIL TO OPERATOR

1. Remove the screws and open the cover of the operator.
2. Remove the chain guard from the chassis.
3. Lay the rail on the floor. Align the key holes on the end of the rail with the cap screws on the chassis.
4. Attach the rail to the chassis with the carriage bolts, lock nuts, and washers provided. Tighten cap screws on key holes.
5. Cut the cable tie on the chain and position the trolley within 3 feet (.9 m) of the end of the rail.
6. Wrap the chain around the sprocket.
7. Adjust the chain tension with the turnbuckle so that the chain hangs no more than 1/4" (.64 cm) from the top of the rail. Tighten the hex nut to secure the chain.
8. Reattach the chain guard to the chassis.
9. Close the cover and attach with screws.

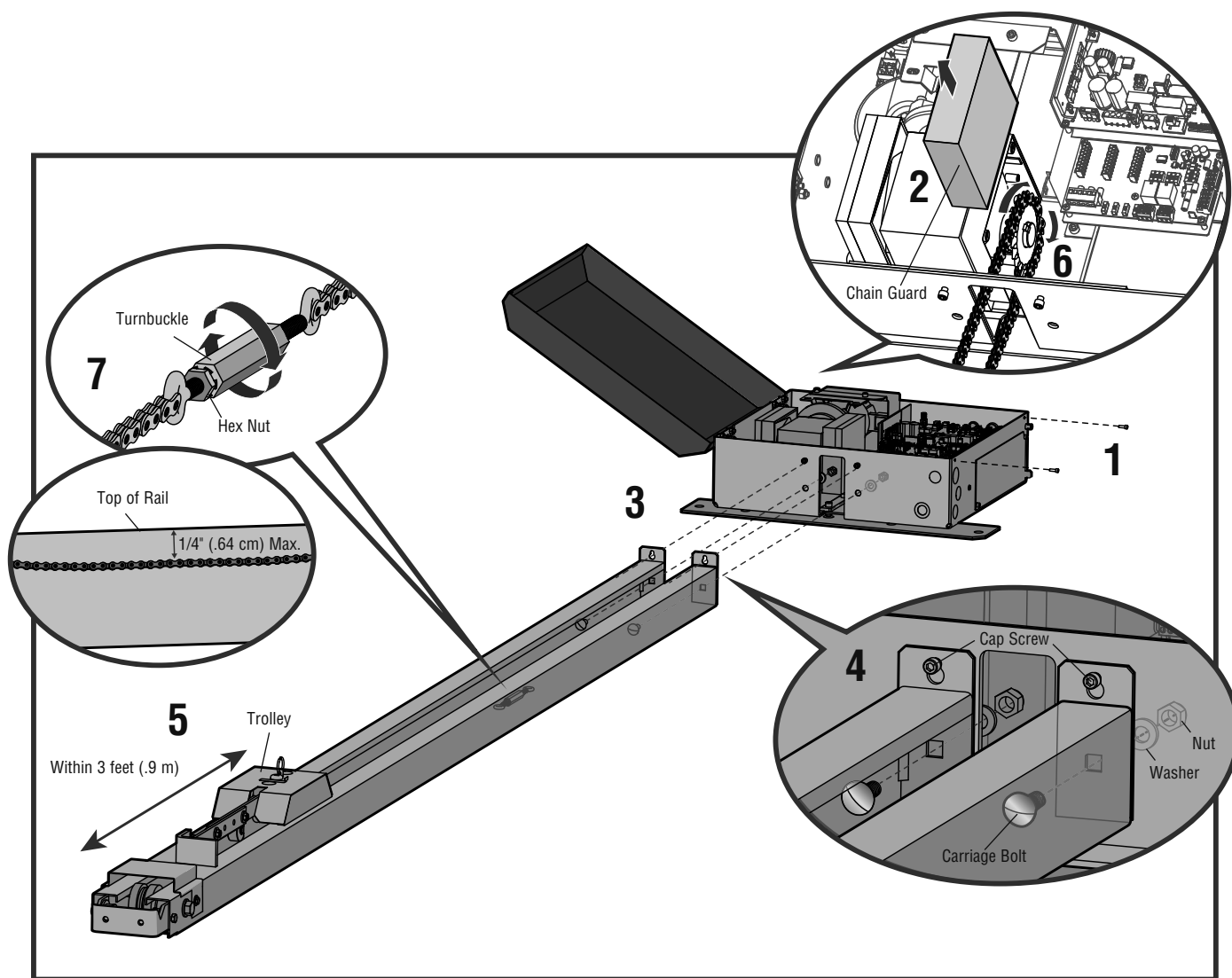

# INSTALLATION

## STEP 2

### INSTALL VENTED PLUG

1. Remove the dome plug from the operator chassis.
2. Remove the solid plug in the gear reducer and replace it with the vented plug (provided in bag with manual).
3. Tighten the vented plug with a socket or Allen wrench.
4. Re-insert the dome plug.

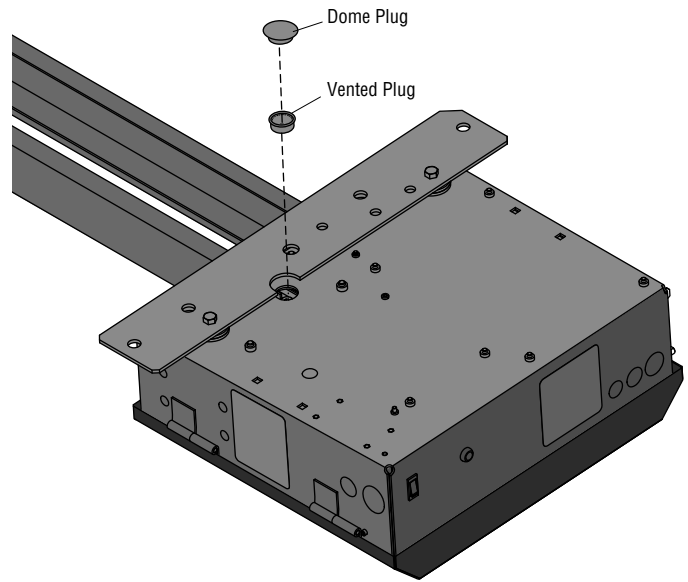

## STEP 3

### DETERMINE LOCATION FOR OPERATOR

1. With the gate/door closed, mark the center.

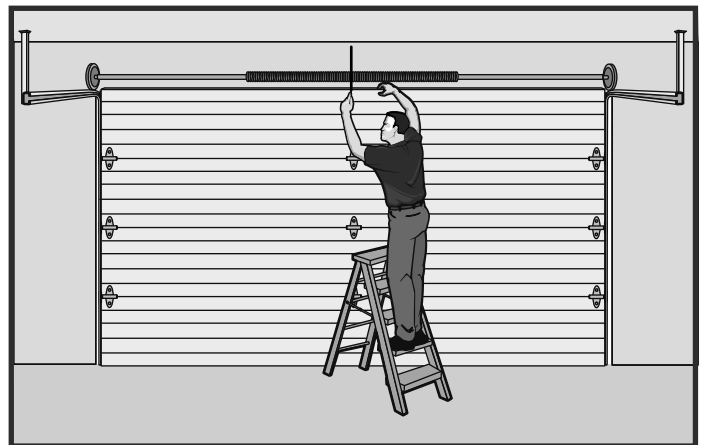
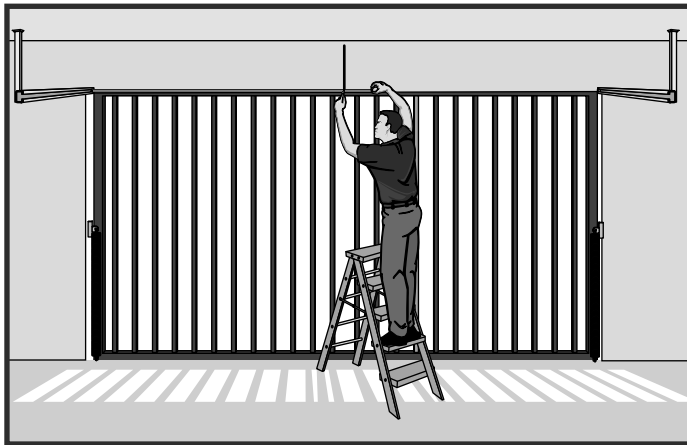

2. Open the gate/door and mark the center point on the ceiling.



# INSTALLATION

## STEP 4

### MOUNT THE OPERATOR

1. Place the motor unit on packing material to protect the cover. Make sure the header bracket is in the center of the opening. Bolt or weld the header bracket to the wall.

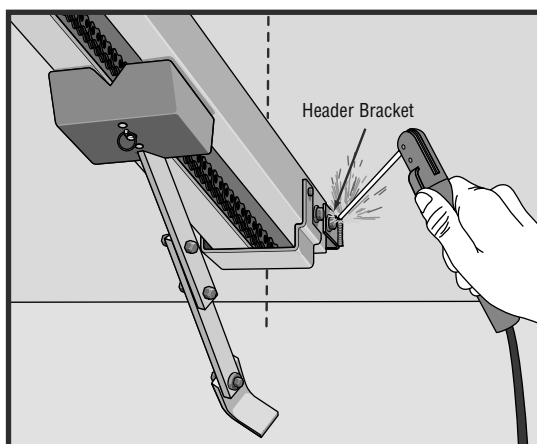
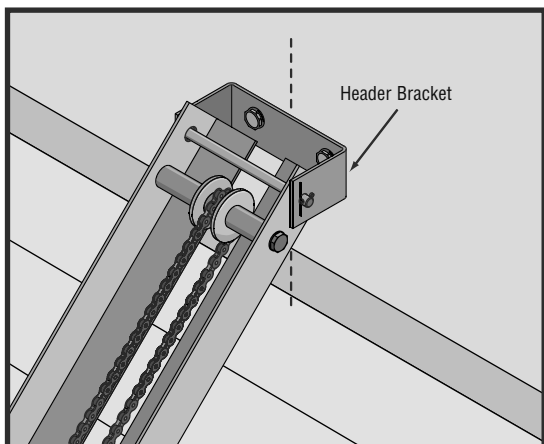

2. Lift the operator and align with center mark on ceiling. Have someone hold the operator in place or use a post as a temporary support. Bolt the operator to the ceiling. (A support post is not part of the operator. Use only for installation.)

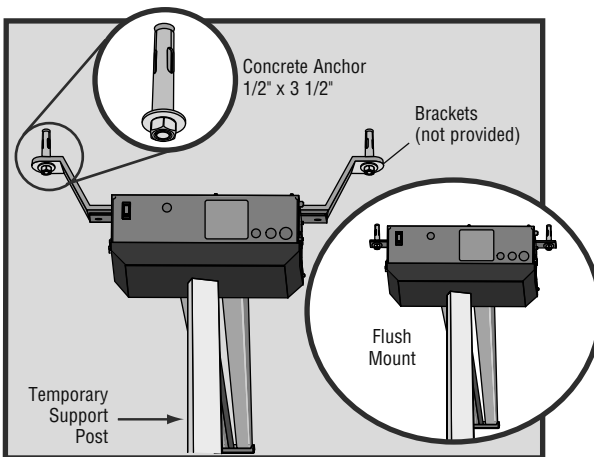
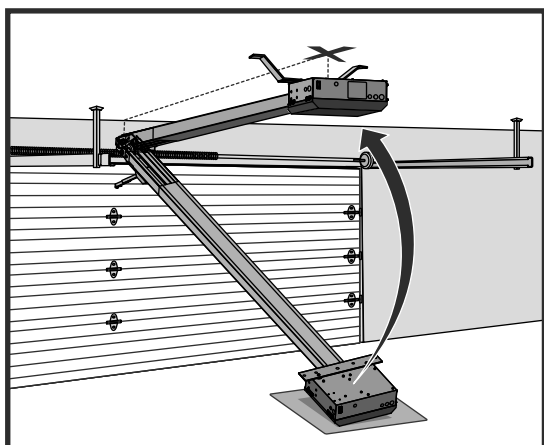

3. Bolt or weld arm to gate/door.

