

1 Connect Internet

The controller can connect to the Internet with LAN (wired) or with Wi-Fi® (wireless). Make sure you are in the Admin Mode before you connect to the Internet. If you are not in Admin Mode, touch the upper left-hand corner of the display. Follow the instructions according to your application.

OPTION 1 Connect with LAN (wired)

The Local Area Network (LAN) port is a 10/100 Ethernet interface with an RJ45 jack for connecting the controller to a LAN in order for it to gain connectivity to the Internet. Use a straight, (i.e., non-crossover) cable to connect to a local hub, switch or router. Connect the Power/Internet Board to a LAN functionality is a supplementary feature.

1. Connect an Ethernet cable from your LAN to the LAN port on the Power/Internet Board. When connected properly, the green and amber LED on the Ethernet port will light/flicker. If the green LED is not lit, check the connections on the controller and the Ethernet hub.
2. On the display, select **Wired Network** if dynamic configuration (DHCP) is desired or select **Manual Setup** for a static IP address.

LAN
on Internet/Power Board

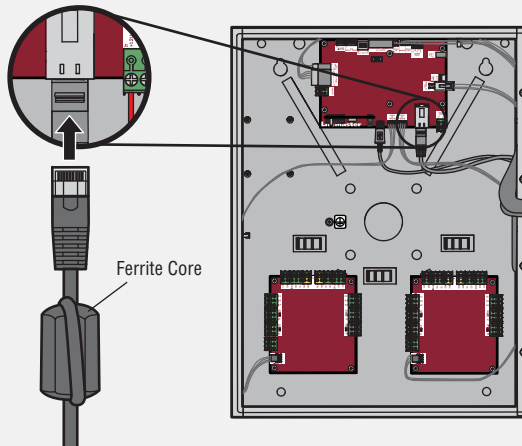

OPTION 2 Connect through Wi-Fi® (Wireless)

1. On the display select **Wi-Fi Network**.
2. Select the network the controller will use.
3. Enter the password for the network.
4. Select **Login**.



2 Validate Setup

On the display, select each tab in Admin Mode to validate setup (network, inputs, outputs, etc.). Once you have validated the setup, exit Admin Mode.

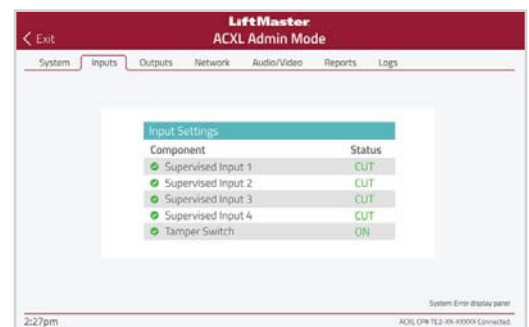

Gate Access (Wired)

Disconnect power BEFORE making electrical connections. Below is an example of a wiring setup for gate access. Gate access can be wired to Door 1, 2, 3, or 4 on the Door Boards. LiftMaster® Security+ 2.0® gate operators can also be programmed to communicate wirelessly instead of using a wired connection (refer to the following page).

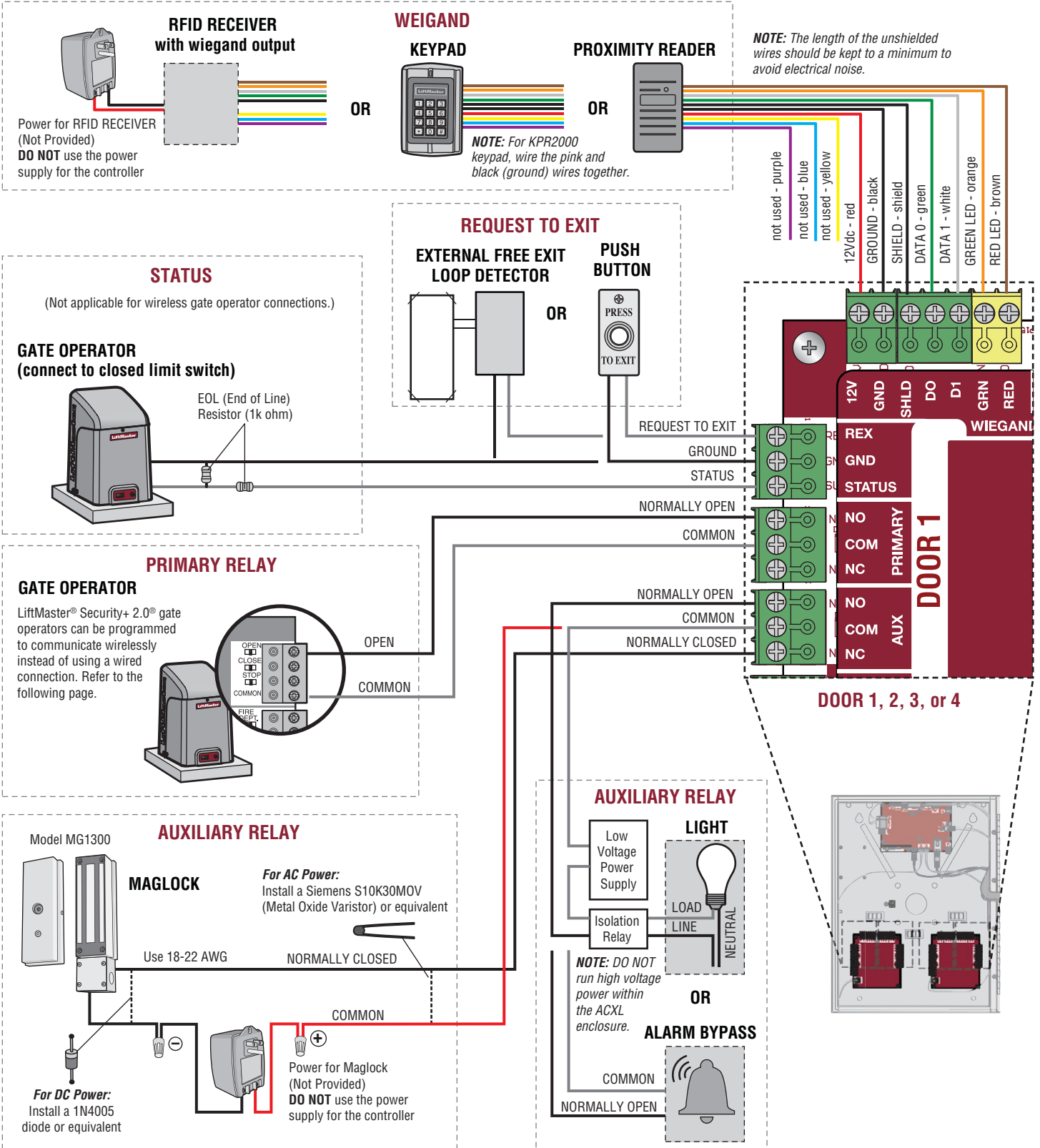

Gate Access (Wireless)

For use with LiftMaster® Security+ 2.0® gate operators.

1 Enter Admin Mode

Touch the upper left-hand corner of the controller display to enter Admin Mode.



2 Select Outputs and Relay

Select the **Outputs** tab. Then select the desired relay on the left-hand side (1 through 4).

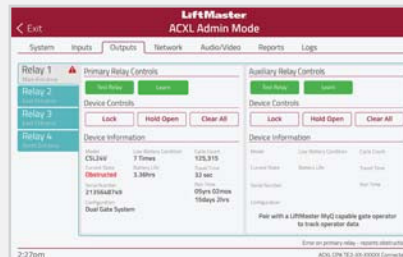

3 Press LEARN button on gate operator

Press and release the LEARN button on the primary operator. The green XMITTER LED will light. **NOTE:** The operator will time out of programming mode after 180 seconds.

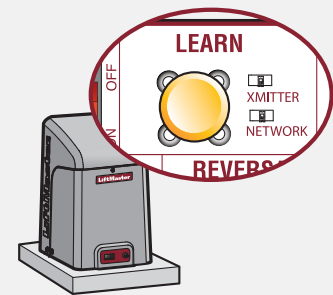

4 Press LEARN button on gate operator again

Press and release the LEARN button again on the primary operator. The yellow NETWORK LED will light.

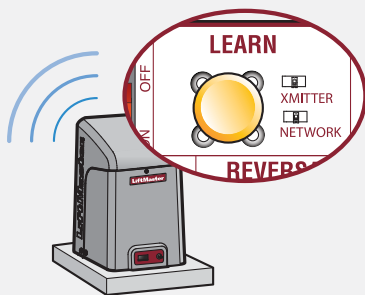

5 Select LEARN on display

Select the LEARN button on the display and the Learn button will go from green to red. The gate operator and the controller will beep and the NETWORK LED on the gate operator will turn off indicating programming is successful.



6 Validate

Validate functionality by selecting **Test Relay** on the controller display.

Door Access

Disconnect power **BEFORE** making electrical connections. Below is an example of a wiring setup for door access. Door access can be wired to Door 1, 2, 3, or 4 on the Door Boards.

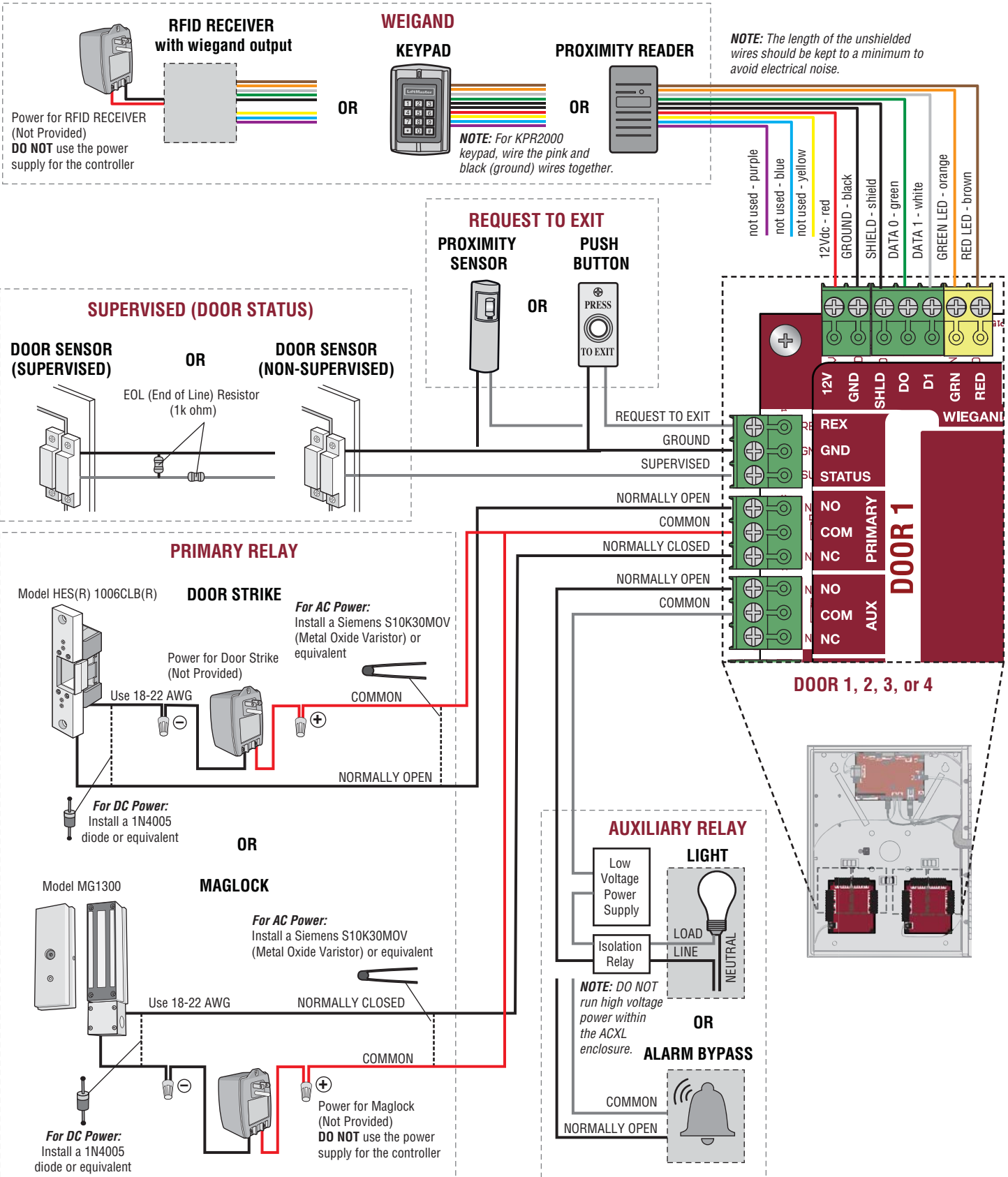

Wiegand Proximity Reader

The controller is designed specifically for the HID PROX-POINT+ MINI READER proximity reader to be mounted on the faceplate.

1. Disconnect power.
2. Remove the mounting plate and gasket from the controller.
3. Use a bench vise with soft jaws to hold the mounting plate and drill a hole for the cable with a 5/16" drill bit.
4. Drill two mounting holes with a 7/64" drill bit. Make the threads using the self-tapping screws provided with the HID reader. **NOTE:** Thread the screw and remove. Clean the mounting hole thoroughly until the entire thread is made.
5. Reinstall the gasket and mounting plate onto the controller.
6. Install the proximity reader and secure with the screws.
7. Apply silicon around the cable hole.
8. The proximity reader can be wired to any of the 4 Wiegand Inputs on the door control boards. Insulate any unused wires from the controller to prevent a short. (Refer to instructions supplied with your Wiegand device for more information.)
9. Connect power.
10. Refer to LiftMaster Cloud for programming.

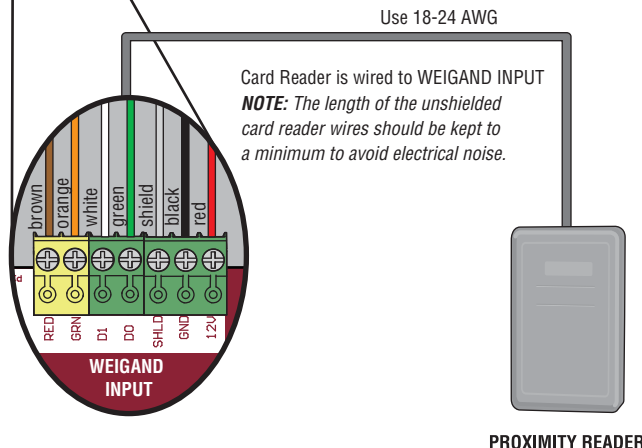
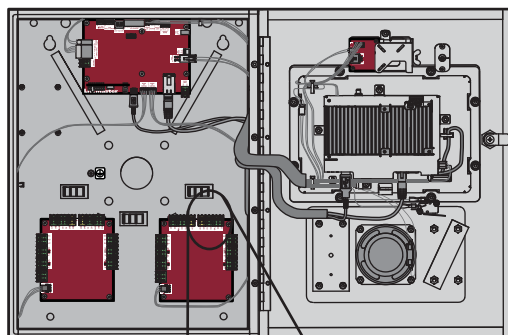
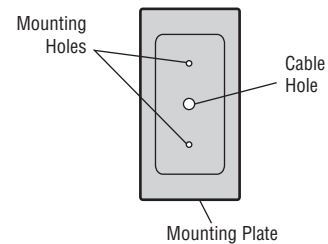
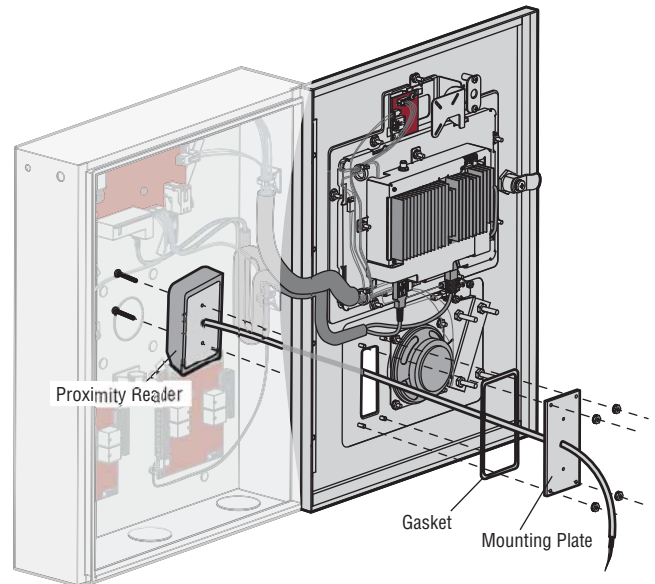

Wiegand Output

Disconnect power BEFORE making electrical connections. The controller offers a Wiegand output capable of 26 bit transmission of the following data:

- Success Call with access granted by the resident. The controller will provide a LMC specified facility code followed by the Directory Code of the resident that granted access.

And/Or

- Successful access through Entry Code. The controller will provide a LMC specified facility code followed by the successful Entry Code.

The two facility codes should be different to prevent duplicate code transmission with the Wiegand Output.

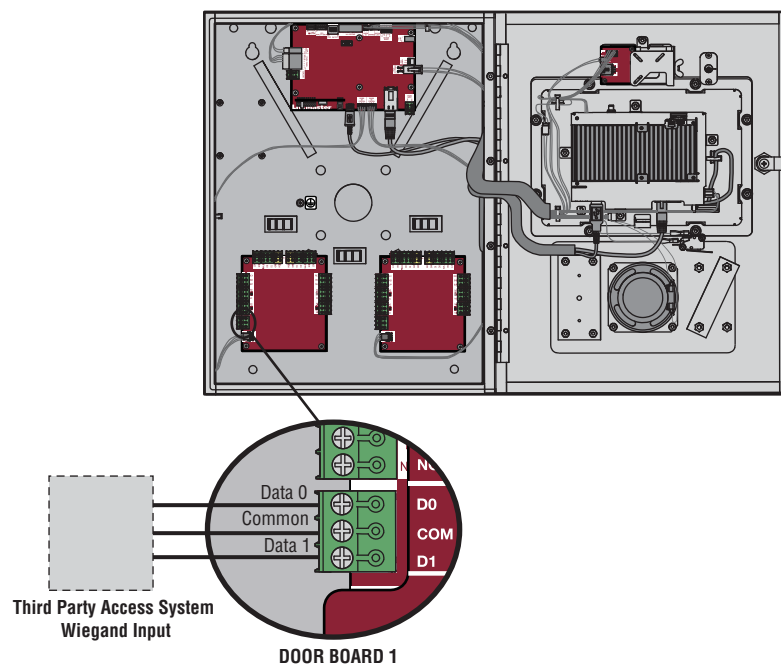

Postal Lock

1. Remove the nuts, retainer bracket, and plug. Discard the retainer bracket and plug.
2. Install the postal lock reusing the nuts previously removed.

The postal lock switch is wired from the factory.

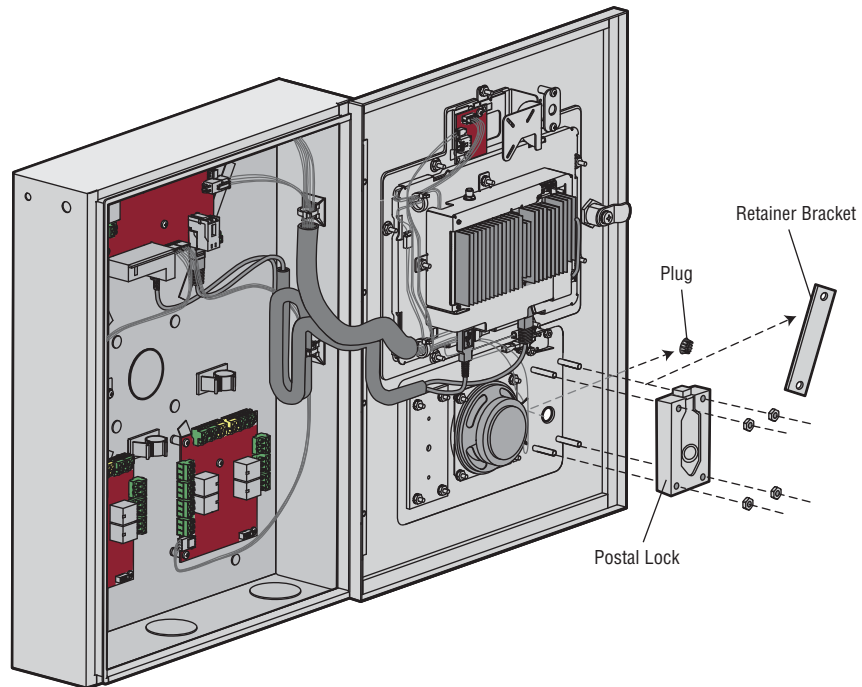

Loop Detector Board

Disconnect power BEFORE making electrical connections. The Loop Detector Board provides Auto Call functionality that is available through the auxiliary switch setting.

1. Secure the Loop Detector Board to the standoffs in the controller with the provided screws.
2. Connect the wire harness from the Loop Detector Board to the Power/Internet Board.
3. Connect the loop wires to the input on the Loop Detector Board.
4. Plug in the loop detector (model LOOPDETLM).
5. Set both switches on the Loop Detector Board to ON (auxiliary setting).

Refer to LiftMaster Cloud for programming.

LOOP MODE	SW1	SW2
EXIT	Not supported	
INTERRUPT	Not supported	
SHADOW	Not supported	
AUXILIARY	ON	ON

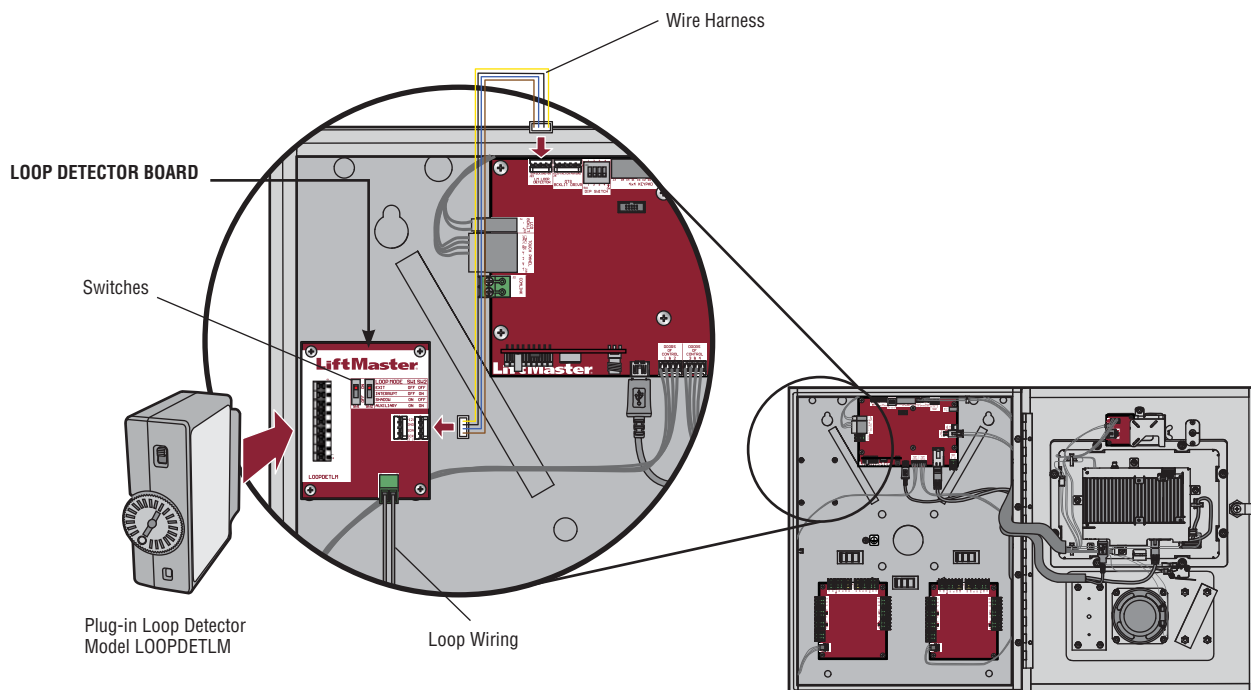



Login to your LiftMaster Cloud Account then follow the steps below.

1 Create a Facility

- On the left navigation bar, click **Facilities**, and click **Add facility**.
- Enter the following information:
 - Facility name
 - Directory code length (required field)
 - Address
 - City/town
 - State
 - Zip code
 - Country (required field)
 - Time zone (required field)
 - Contact information- This is required. The contact is typically the property manager
- Click **Save**.

2 Add New Controller(s)

- The Control Panel # is required to add a controller to a facility. The Control Panel # is located on the product label.
- On the left navigation bar, click **Facilities** or **Dashboard**.
 - Select the name of the facility where the new controller will be added.
 - Click on the **Controllers** tab.
 - Click **Add New Controller**.
 - Enter the Control Panel # (CP#) and the name of the controller.
 - Click **Save**. The Controller will appear on the list, a browser refresh may be necessary.

3 Add Door(s)

- NOTE: Door 1 is automatically created and associated to the Door 1 relay. This step is to configure Relay 2.**
- On the left navigation bar, click **Facilities** or **Dashboard**.
 - Select the facility.
 - Click on the **Controllers** tab and select the controller you want to add the door to.
 - Click on the **Doors** tab next to the Controller Settings.
 - Select **Relay 2** to control the door.
 - Click **Add Door**.
 - Enter the name of the door.
 - Click **Save and Close**.

4 Add Schedule(s)

- On the left navigation bar, click **Schedules**.
- Select the name of the facility.
- Click **Add Schedule** and enter schedule information:
 - Name of schedule
 - Description of schedule
 - Do not select an **Enabling Group** unless you want a member of the enabled group to activate the schedule when they enter their entry code. **NOTE: The schedule is not applied or activated until a member of the group accesses the property using a credential or pin.**
- To select a range of hours and days, click on the hour and day and drag to create the schedule or you may click on individual hours and days.
- Add holidays and exceptions.
- Click **Save**.

5 Create Group(s)

- On the left navigation bar, click **Groups**.
- Select the facility you are creating a group for.
- Click **Add Group**.
- Enter a name for the new group.
- Select the Status (active or suspended).
- Click **People** and click **Add users+**.
- Select the people for the group by clicking on the + next to the name of the person.
- Add the zones for this group by, click **Zones** and click **Add Zones+**.
- Select the zones by clicking on the + next to the name of zone.
- Click **Save**.

6 Create Zone(s)

- On the left navigation bar, click **Facilities** or **Dashboard**.
- Select the facility.
- Click on the **Zones** tab.
- Click **Add New Zone**.
- Enter name of the zone.
- Click **Doors**.
- Click **Add doors+** and click on the + next to the name of the door.
- Click on **Groups**.
- Click on **Add Groups+** and select the Groups for the new zone.
- Select the schedule from the drop-down list.
- Click **Save**.

7 Add a Credential

- On the left navigation bar, click **Credentials**.
- Select the facility.
- Click **Add credential**.
- Select the **Type**: Card or transmitter.
- Select the **Format**: Standard 26 bit or 30-Bit Wiegand.
- Enter the card or transmitter information:
 - Card number
 - Offset
 - Facility code
 - Vendor code (30-Bit Wiegand ONLY)
- Click **Save**.

NOTE: If adding multiple credentials, click Bulk load, enter the first and last number in the series, the offset of the first card, and the facility code.

8 Add People

- On the left navigation bar, click **People**.
- Select the facility.
- Click **Add Person**.
- From the **Profile** tab, Personal, enter the following information:
 - Email (optional)
 - First and last name
 - Role (use -- in most cases)
- In Contact, select the **Do not disturb** schedule check box if desired.
- In Contact, enter the following information:
 - Phone numbers
 - Address, city, state, and zip code
- Click, **Save**.
- Click the **Vehicle Information** tab, enter vehicle information if desired.
- Click **Add a new vehicle**.
- Enter the vehicle information:
 - Year
 - Make
 - Model
 - State
 - License plate number
 - Color
- Click **Add vehicle** to add another vehicle to the person's profile.
- Click, **Save**.
- Setup **Facility Access**. If the person is to be called by the system you will need to set up the Facility Access Directory.
 - From the add people screen, click the **Facility Access** tab.
 - Enter the directory information, click **Verify**. If you want the system to automatically assign a directory code, click **Generate Code**.
 - Enter a **PIN**, click **Verify**. If you want the system to automatically assign a PIN, click Generate PIN. Select **Credentials** for this person by clicking in the blank space in the **Cards/Transmitters** field and select one a credential.
- Set **Access**
 - If you want to set activation and expiration dates, click the **Calendar** icon for activation, select the date for activation. Click the **Calendar** icon for expiration, select the date you want their access to expire.
 - Select the **Groups(s)** for this person, click in the blank space in the **Access Groups** field.
- Click **Save**.

Wiring Diagram

CAUTION

Not responsible for conflicts between the information listed in the wiring diagram and the requirements of your local building codes. The information is for suggested use ONLY. Check your local codes BEFORE installation.

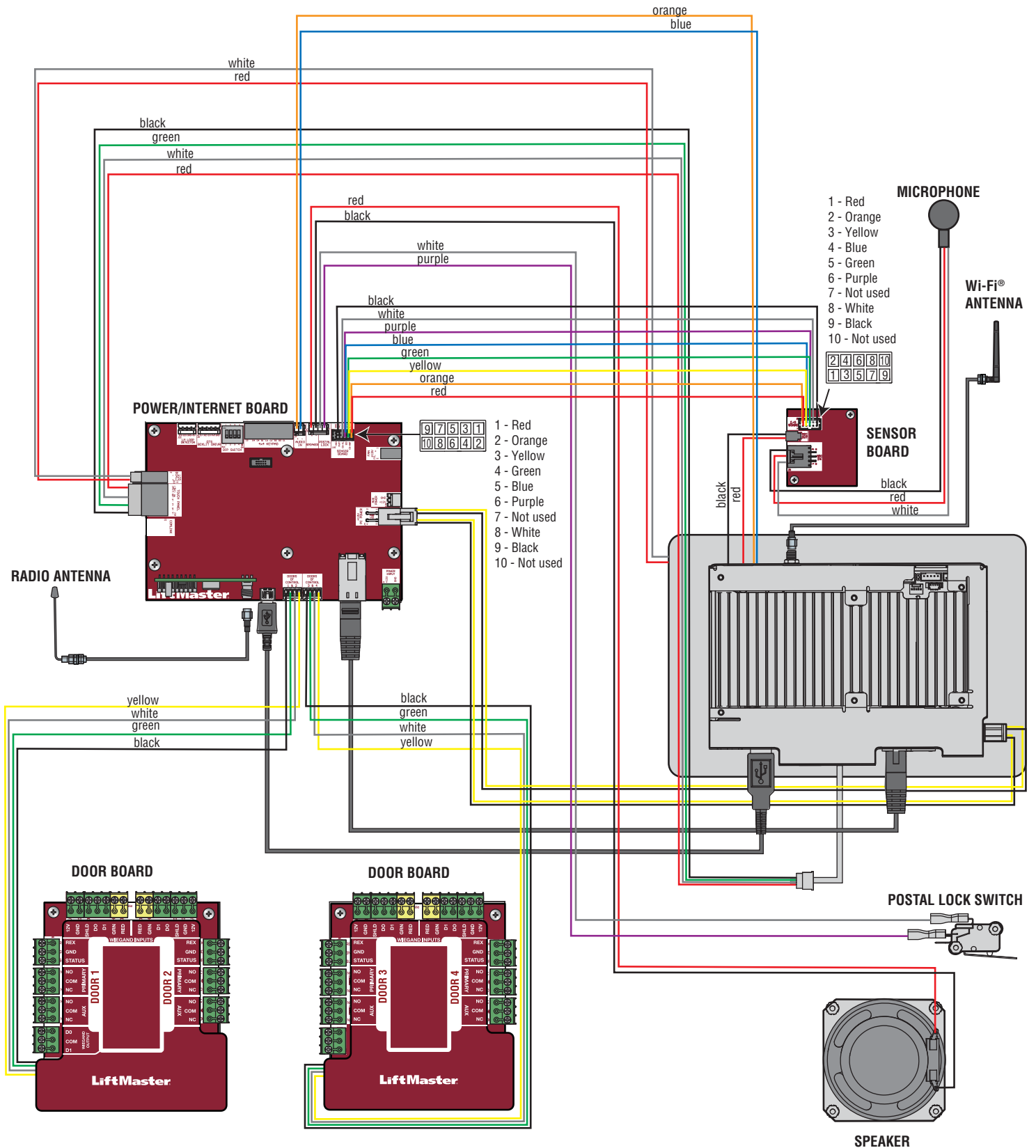

Repair Parts

COMING SOON

PLEASE CONTACT LIFTMASTER FOR ALPHA TEST REPAIR PART INFORMATION:
1.877.232.7987

Accessories

ITEM	PART NUMBER
Back Box and Trim Kit	ACXLTk
ACXL Hood Kit	ACXLHOOD
Card Reader Multi-class SE RP10 Mini Mullion	LMMC-MINI
Radio Antenna Extension (15 foot)	86LM
Wi-Fi Antenna Extension (15 foot)	WIFIEXT
Wiegand Keypad/Proximity Reader	KPR2000
Wiegand Proximity Reader	PPLX
Loop Detector Kit (Complete with: Loop Detector Board, Plug-In Loop Detector [model LOOPDETLm], and wire harness)	TBD
All LiftMaster® MyQ®/UL325 compatible gate operators	
Passport 3-Button Visor Remote Control MAX	PPV3M
Passport 3-Button Mini Remote Control MAX	PPK3M
Passport 3-Button Mini Proximity Remote Control MAX	PPK3PHM
Passport Lite 1-Button Visor Remote	PPLV1-X*
Passport Lite 1-Button Key Chain Remote	PPLK1-X*
Passport Lite 1-Button Mini Proximity Remote	PPLK1PH-X*

* Available in 10 and 100 packs, replace X with 10 or 100

Configuration Sheet

Record device information and configuration settings below.

Controller Name:
<i>NOTE: Any user of the system is subject to the terms outlined in the product EULA.</i>
Notes:

DEVICE CONFIGURATION:

DOOR 1	DOOR/GATE NAME:			
INPUTS	WIEGAND	REX	STATUS	
				EOL (Y / N)
OUTPUTS	PRIMARY RELAY		AUXILIARY RELAY	
	N.O.	N.C.	N.O.	N.C.
Notes:				

DOOR 2	DOOR/GATE NAME:			
INPUTS	WIEGAND	REX	STATUS	
				EOL (Y / N)
OUTPUTS	PRIMARY RELAY		AUXILIARY RELAY	
	N.O.	N.C.	N.O.	N.C.
Notes:				

DOOR 3	DOOR/GATE NAME:			
INPUTS	WIEGAND	REX	STATUS	
				EOL (Y / N)
OUTPUTS	PRIMARY RELAY		AUXILIARY RELAY	
	N.O.	N.C.	N.O.	N.C.
Notes:				

DOOR 4	DOOR/GATE NAME:			
INPUTS	WIEGAND	REX	STATUS	
				EOL (Y / N)
OUTPUTS	PRIMARY RELAY		AUXILIARY RELAY	
	N.O.	N.C.	N.O.	N.C.
Notes:				

Legal Disclaimers

Federal Communications Commission (FCC) Compliance

This equipment has been tested and found to comply with the limits for a Class B digital device, pursuant to Part 15 of the FCC Rules. These limits are designed to provide reasonable protection against harmful interference in a residential installation or when the equipment is operated in a commercial environment. This equipment generates, uses and can radiate radio frequency energy and, if not installed and used in accordance with the instruction manual, may cause harmful interference to radio communications. However, there is no guarantee that interference will not occur in a particular installation. If this equipment does cause harmful interference to radio or television reception, which can be determined by turning the equipment off and on, the user is encouraged to try to correct the interference by one or more of the following measures:

- Increase the distance between the equipment and receiver.
- Connect the equipment to a circuit other than the one to which the receiver is connected.
- Consult the dealer for help.

Canada-Underwriters Laboratories (C-UL) Compliance

For C-UL Listed applications, the controller shall be installed in accordance with Part 1 of the Canadian Electrical Code.

Documentation Disclaimer and Restrictions

Information in this document is subject to change without notice and does not represent a commitment on the part of LiftMaster. For the most up-to-date information, visit www.LiftMaster.com.

This document and the data herein shall not be duplicated, used or disclosed to others for procurement or manufacturing, except as authorized with the written permission of LiftMaster. The information contained within this document or within the product itself is considered the exclusive property of LiftMaster. All information in this document or within the hardware and software product themselves is protected by the copyright and/or other intellectual property laws of the United States.

UL 294 Access Control Unit Level 1

NOTICE: To comply with FCC and/or Industry Canada (IC) rules, adjustment or modifications of this digital device are prohibited. THERE ARE NO USER SERVICEABLE PARTS. Any changes or modifications not expressly approved by the party responsible for compliance could void the user's authority to operate the equipment.

This device complies with Part 15 of the FCC rules and IC License-Exempt RSS Standard(s). Operation is subject to the following two conditions: (1) this device may not cause harmful interference, and (2) this device must accept any interference received, including interference that may cause undesired operation.

This Class B digital apparatus complies with Canadian ICES-003.

This device has been tested and found to comply with the limits for a Class B digital device, pursuant to part 15 of the FCC rules. These limits are designed to provide reasonable protection against harmful interference in a residential installation. This equipment generates, uses and can radiate radio frequency energy and, if not installed and used in accordance with the instructions, may cause harmful interference to radio communications. However, there is no guarantee that interference will not occur in a particular installation. If this equipment does cause harmful interference to radio or television reception, which can be determined by turning the equipment off and on, the user is encouraged to try to correct the interference by one or more of the following measures:

- Reorient or relocate the receiving antenna.
- Increase the separation between the equipment and receiver.
- Connect the equipment into an outlet on a circuit different from that to which the receiver is connected.
- Consult the dealer or an experienced radio/TV technician for help.
- This device must be installed in a way where a minimum 8" (20 cm) distance is maintained between users/bystanders and device.

AVIS : Les règles de la FCC et/ou d'Industrie Canada (IC) interdisent tout ajustement ou toute modification de ce récepteur. IL N'EXISTE AUCUNE PIÈCE SUSCEPTIBLE D'ÊTRE ENTRETENUE PAR L'UTILISATEUR. Tout changement ou toute modification non expressément approuvé par la partie responsable de la conformité peut avoir pour résultat d'annuler l'autorité de l'utilisateur de faire fonctionner l'équipement.

Ce dispositif est conforme à la partie 15 des règles de FCC et des normes Permis-Exemptes d'IC RSS. Son utilisation est assujettie aux deux conditions suivantes : (1) ce dispositif ne peut causer des interférences nuisibles, et (2) ce dispositif doit accepter toute interférence reçue, y compris une interférence pouvant causer un fonctionnement non souhaité.

Cet appareil numérique de la classe B est conforme à la norme NMB-003 du Canada.

Ce dispositif a été mis à l'essai et déclaré conforme aux limites établies pour les dispositifs numériques de classe B, conformément à l'article 15 des règles de la FCC. Cette conformité a pour but de fournir une protection raisonnable contre les interférences nuisibles dans une installation résidentielle. Cet équipement génère, utilise et peut émettre des fréquences radio et, s'il n'est pas installé et utilisé conformément aux instructions, causer des interférences nuisibles aux communications radio. Cependant, il n'existe aucune garantie que des interférences ne se produiront pas dans une installation particulière. Si cet équipement provoque des interférences nuisibles à la réception d'une diffusion sonore ou visuelle, ce qui peut être déterminé en l'allumant et en l'éteignant, l'utilisateur est invité à essayer de résoudre ce problème en prenant une ou plusieurs des mesures suivantes :

- Réorienter ou déplacer antenne de réception.
- Augmenter la distance entre l'équipement et le récepteur.
- Brancher l'appareil à une prise sur un circuit différent de celui du récepteur.
- Pour obtenir de l'aide, consulter le détaillant ou un radiotechnicien expérimenté.
- Ce dispositif doit être installé de manière à ce qu'une distance d'au moins 20 cm (8 po) soit maintenue entre les utilisateurs/passants et le dispositif.

Warranty

LiftMaster ("Seller") warrants to the first purchaser of this product, for the structure in which this product is originally installed, that it is free from defect in materials and/or workmanship for a period of two years from the date of purchase.

The proper operation of this product is dependent on your compliance with the instructions regarding installation, operation, maintenance and testing. Failure to comply strictly with those instructions will void this limited warranty in its entirety.

If, during the limited warranty period, this product appears to contain a defect covered by this limited warranty, call 1-800-528-2806 before dismantling this product. Then send this product, pre-paid and insured, to our service center for warranty replacement. Products returned to Seller for warranty replacement, which upon receipt by Seller are confirmed to be defective and covered by this limited warranty, will be replaced (at Seller's sole option) at no cost to you and returned pre-paid. Defective parts will be replaced with new or factory-rebuilt parts at Seller's sole option.

THIS LIMITED WARRANTY IS IN LIEU OF ANY OTHER WARRANTIES, EXPRESS OR IMPLIED, INCLUDING ANY IMPLIED WARRANTY OF MERCHANTABILITY OR FITNESS FOR A PARTICULAR PURPOSE OR OTHERWISE, AND OF ANY OTHER OBLIGATIONS OR LIABILITY ON SELLER'S PART. THIS LIMITED WARRANTY DOES NOT COVER NON-DEFECT DAMAGE, DAMAGE CAUSED BY IMPROPER INSTALLATION, OPERATION OR CARE (INCLUDING, BUT NOT LIMITED TO ABUSE, MISUSE, FAILURE TO PROVIDE REASONABLE AND NECESSARY MAINTENANCE, UNAUTHORIZED REPAIRS OR ANY ALTERATIONS TO THIS PRODUCT), LABOR CHARGES FOR REINSTALLING A REPAIRED OR REPLACED UNIT, PROBLEMS RELATED TO INTERFERENCE, OR REPLACEMENT OF BATTERIES.

UNDER NO CIRCUMSTANCES SHALL SELLER BE LIABLE FOR CONSEQUENTIAL, INCIDENTAL OR SPECIAL DAMAGES ARISING IN CONNECTION WITH USE, OR INABILITY TO USE, THIS PRODUCT. IN NO EVENT SHALL SELLER'S LIABILITY FOR BREACH OF WARRANTY, BREACH OF CONTRACT, NEGLIGENCE OR STRICT LIABILITY EXCEED THE COST OF THE PRODUCT COVERED HEREBY. NO PERSON IS AUTHORIZED TO ASSUME FOR US ANY OTHER LIABILITY IN CONNECTION WITH THE SALE OF THIS PRODUCT.

Some states do not allow the exclusion or limitation of consequential, incidental or special damages, so the above limitation or exclusion may not apply to you. This limited warranty gives you specific legal rights, and you may also have other rights which vary from state to state.

Wi-Fi® is a registered trademark of Wi-Fi Alliance.

© 2016 LiftMaster
All rights reserved.

ALPHA