

# CHAMPION

POWER EQUIPMENT™

OWNER'S MANUAL & OPERATING INSTRUCTIONS



## WINCH WIRELESS REMOTE KIT



MODEL NUMBER

**18029**

**SAVE THESE INSTRUCTIONS**  
Important Safety Instructions  
are included in this manual.

MADE IN CHINA  
REV 18029-20111222

10006 Santa Fe Springs Road  
Santa Fe Springs, CA 90670  
USA / 1-877-338-0999  
[www.championpowerequipment.com](http://www.championpowerequipment.com)

**Have questions or need assistance?**

*Do not return this product to the store!*

**WE ARE HERE TO HELP!**

Visit our website:

**[www.championpowerequipment.com](http://www.championpowerequipment.com)**

for more info:

- Product Info and Updates
- Tech Bulletins
- Frequently Asked Questions
- Product Registration

– or –

Call our Customer Care Team Toll-Free at:

**1-877-338-0999**

## Winch Wireless Remote Kit

\*Mounting hardware not shown.

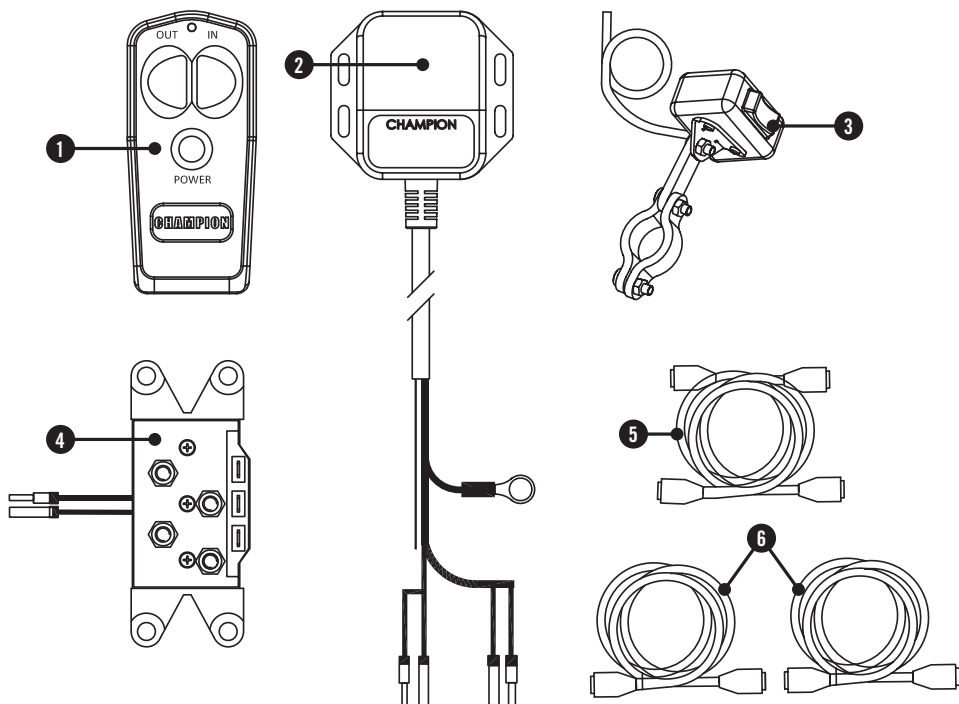

- (1) **Wireless Remote Control** – Used to power the rope in or out of your winch drum.
- (2) **Antenna** – Receives wireless signal from wireless remote control from within a 50 ft. radius.
- (3) **Rocker Switch** – Rocker switch with handlebar mount for powering the rope in or out of your winch drum.
- (4) **Solenoid/Contactor** – Power from the vehicle battery flows through the weather sealed solenoid/contactor switch before being directed to the winch motor.
- (5) **Battery Connection Cables** – Used to connect the battery to the solenoid/contactor.
- (6) **Winch Connection Cables** – Used to connect the winch motor to the solenoid/contactor.

# ASSEMBLY

## 1) Install Solenoid/Contactor

Find a location for the contactor. If the model specific mounting kit does not indicate a recommended contactor location, then it is recommended that the contactor be mounted close to the battery in a clean dry location. Make sure the location you chose allows sufficient clearance from all metal components. Drill mounting holes if required. Once location is found do not install until all wiring is completed.

## 2) Install Rocker Switch

1. Decide which handlebar the switch will be mounted on. The switch is usually installed on the left handlebar.
2. Use a piece of electrical tape around the handlebar to help prevent rotation of the mount on the handlebar. Do NOT tighten over any hoses or cables.
3. Once your switch is mounted you can route the wires back to where your contactor is located.
4. Splice the end of the RED wire to an ignition (keyed) controlled power source using the supplied wire tap. You may need to use a test light to locate a suitable wire. The wire should only have power when the key is in the ON position.
5. Make sure the handlebars have full range of motion and then secure the switch's cable with the supplied cable ties.

## 3) Wiring the Winch

### ! CAUTION

**Never** route electrical cables across any sharp edges, through or near moving parts, or near parts that become hot.

1. Connect the yellow and blue cables to the motor terminals on the winch. Torque the terminal nuts on the motor to 5.7 N-m (50 lb-in). Route the other ends to the contactor location.
2. Connect the yellow and blue cables to the contactor (yellow to yellow and blue to blue). Do NOT tighten nuts.
3. Connect the red and black cables to your contactor (red to red and black to black). Do NOT tighten nuts. Route the other ends to your battery location.

### ! CAUTION

Battery cables should not be drawn taut. Leave some slack for cable movement.

4. Connect the rocker switch to the contactor (black to black and green to green).
5. Once all wiring is connected to the contactor you can then mount it using the supplied M6 hardware.
6. Torque the contactor terminal nuts to 4.5 N-m (40 lb-in). Do NOT over tighten.
7. Place all terminal boots over terminals and secure all cables with cable ties or electrical tape (not included).
8. Connect the battery leads from the contactor to the ATV's Battery (red to red and black to black).

### NOTE

Depending on the location of the contactor, you may need to use the black and red cables in place of the yellow and blue, and the yellow and blue in place of the red and black. Just remember that this also changes the diagram.

#### 4) Install the Antenna

1. Determine the mounting location.
2. If mounting on a flat surface, mark and drill a minimum of two (2) mounting holes, one on each side of the antenna. Loosely attach the antenna using the supplied bolts and lock nuts. Do NOT tighten fasteners at this time.
3. If mounting on a frame tube, loosely attach using the supplied cable ties.
4. Locate the black and green wires running from the contactor to the rocker switch. Find the bullet connectors on these wires located near the contactor.
5. Plan a route for the wire harness between the antenna and these bullet connectors.
6. Pull apart the bullet connectors on the BLACK and GREEN wires identified in step 4 above. These will be located near the contactor
7. Connect the rocker switch and contactor to the antenna (black to black and green to green).
8. Connect the black ground wire with the ring to the black (-) terminal on the solenoid/contactor.

#### 5) Test Winch Operation

1. Make sure there are no exposed terminals or wiring, and wiring to all components is correct, all loose wires are secured.
2. Turn ATV ignition switch to the ON position.
3. Check the winch for proper operation using the rocker switch. The wire rope should spool in and out in the direction indicated on the switch.
4. To use test wireless system, activate the system by pressing and holding the POWER button on the wireless remote for 3 seconds. This transfers control of the winch to the wireless control system. A red indicator light on the wireless remote turns on when the system is active and ready to use.

#### NOTE

##### Led Indicator Light

- Steady Red: System active and ready to use.
- Flashing Red: Winch powering in or out.

5. Verify that the winch spools the rope in and out properly by pressing the buttons on the wireless remote. The wire rope should spool in and out in the direction indicated on the remote.
6. Deactivate the system by pressing the POWER button on the wireless remote and holding for 3 seconds, until red light turns off or after 2 mins of idle time, the wireless system de-activates.

#### WARNING

This kit is designed for use on front mounted self-recovery winches only. The remote is not designed for and should not be used on winches or hoists in industrial applications (car haulers/carriers, wrecker, cranes, etc.) or for any other remote controlled applications.

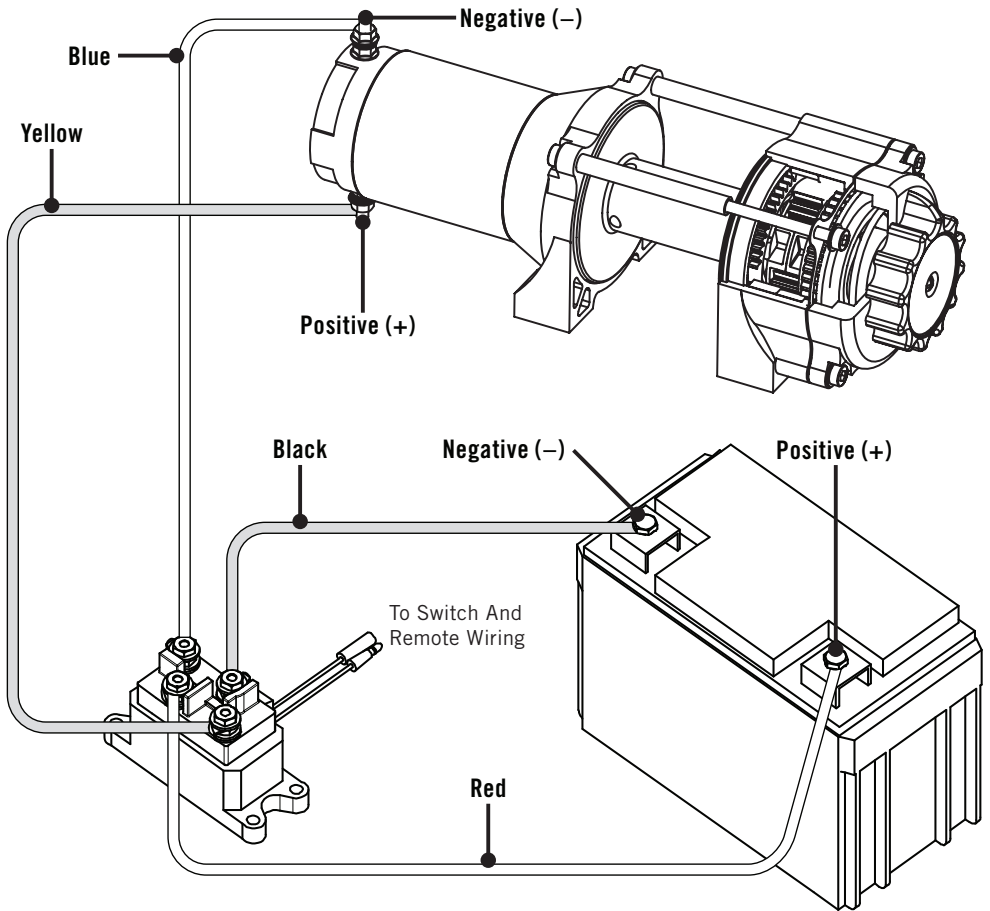
**ASSEMBLY****Solenoid/Contactor Wiring Diagram**

# Antenna Wiring Diagram

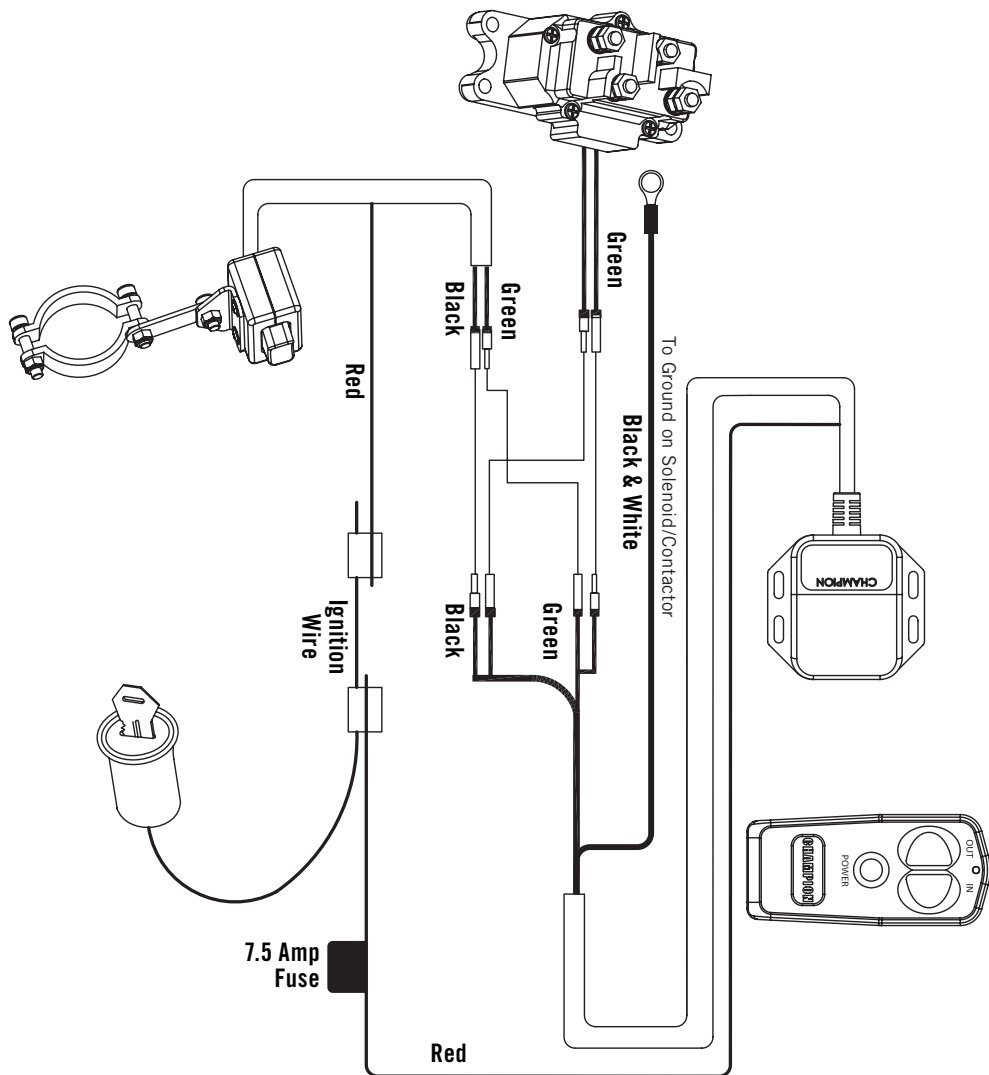

# WARRANTY

## WARRANTY

CHAMPION POWER EQUIPMENT  
2 YEAR LIMITED WARRANTY

### Warranty Qualifications

Champion Power Equipment (CPE) will register this warranty upon receipt of your Warranty Registration Card and a copy of your sales receipt from one of CPE's retail locations as proof of purchase.

Please submit your warranty registration and your proof of purchase within ten (10) days of the date of purchase.

### Repair/Replacement Warranty

CPE warrants to the original purchaser that the mechanical and electrical components will be free of defects in material and workmanship for a period of one year (parts and labor) and two years (parts) from the original date of purchase (90 days [parts and labor] and 180 days [parts] for commercial & industrial use). Transportation charges on product submitted for repair or replacement under this warranty are the sole responsibility of the purchaser. This warranty only applies to the original purchaser and is not transferable.

### Do Not Return The Unit To The Place Of Purchase

Contact CPE's Technical Service and CPE will troubleshoot any issue via phone or e-mail. If the problem is not corrected by this method, CPE will, at its option, authorize evaluation, repair or replacement of the defective part or component at a CPE Service Center. CPE will provide you with a case number for warranty service. Please keep it for future reference. Repairs or replacements without prior authorization, or at an unauthorized repair facility, will not be covered by this warranty.

### Warranty Exclusions

This warranty does not cover the following repairs and equipment:

#### Normal Wear

This product needs periodic parts and service to perform well. This warranty does not cover repair when normal use has exhausted the life of a part or the equipment as a whole.

### Installation, Use and Maintenance

The warranty excludes:

- Cosmetic defects such as paint, decals, etc.
- Failures due to acts of God and other force majeure events beyond the manufacturer's control.
- Problems caused by parts that are not original Champion Power Equipment parts.

### Other Exclusions

This warranty excludes: Cosmetic defects such as paint, decals, etc. Failures due to acts of God and other force majeure events beyond the manufacturer's control.

Problems cause by parts that are not original Champion Power Equipment parts.

### Limits of Implied Warranty and Consequential Damage

Champion Power Equipment disclaims any obligation to cover any loss of time, use of this product, freight, or any incidental or consequential claim by anyone from using this product. THIS WARRANTY IS IN LIEU OF ALL OTHER WARRANTIES, EXPRESS OR IMPLIED, INCLUDING WARRANTIES OF MERCHANTABILITY OR FITNESS FOR A PARTICULAR PURPOSE

A unit provided as an exchange will be subject to the warranty of the original unit. The length of the warranty governing the exchanged unit will remain calculated by reference to the purchase date of the original unit.

This warranty gives you certain legal rights which may change from state to state. Your state may also have other rights you may be entitled to that are not listed within this warranty.

### Contact Information

#### Address

Champion Power Equipment, Inc.  
Customer Service  
10006 Santa Fe Springs Rd.  
Santa Fe Springs, CA 90670  
[www.championpowerequipment.com](http://www.championpowerequipment.com)

#### Customer Service

Mon – Fri 8:30 AM – 5:00 PM (PST/PDT)  
Toll Free: 1-877-338-0999  
Fax no.: 1 (562) 236-9429

#### Technical Service

Mon – Fri 8:30 AM – 5:00 PM (PST/PDT)  
Toll Free: 1-877-338-0999  
[tech@championpowerequipment.com](mailto:tech@championpowerequipment.com)