

# CHAMPION

POWER EQUIPMENT™

OWNER'S MANUAL AND OPERATING INSTRUCTIONS

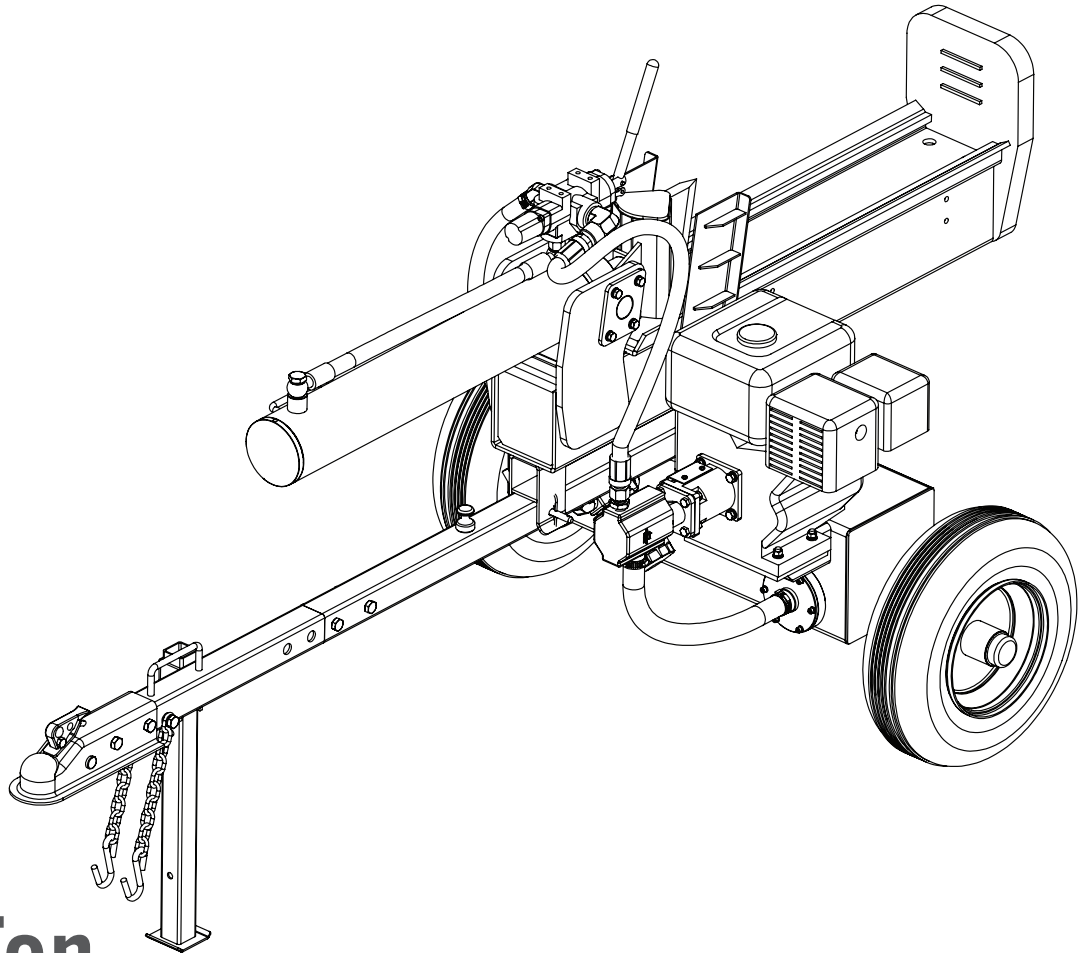

## 22 Ton LOG SPLITTER



MODEL NUMBER

**92251-1**

**SAVE THESE INSTRUCTIONS**  
Important Safety Instructions  
are included in this manual.

MADE IN CHINA  
REV 92251-1-20131206

10006 Santa Fe Springs Road  
Santa Fe Springs CA 90670  
USA / 1-877-338-0999  
[www.championpowerequipment.com](http://www.championpowerequipment.com)

**AN IMPORTANT MESSAGE ABOUT TEMPERATURE:**

Your Champion Power Equipment product is designed and rated for continuous operation at ambient temperatures up to 40°C (104°F). When your product is needed your product may be operated at temperatures ranging from -15°C (5°F) to 50°C (122°F) for short periods. If the product is exposed to temperatures outside this range during storage, it should be brought back within this range before operation. In any event, the product must always be operated outdoors, in a well-ventilated area and away from doors, windows and other vents.

**Have questions or need assistance?**

Do not return this product to the store!

**WE ARE HERE TO HELP!**

Visit our website:

**[www.championpowerequipment.com](http://www.championpowerequipment.com)**

for more info:

- Product Info & Updates
- Tech Bulletins
- Frequently Asked Questions
- Product Registration

– or –

Call our Customer Care Team Toll-Free at:

**1-877-338-0999**

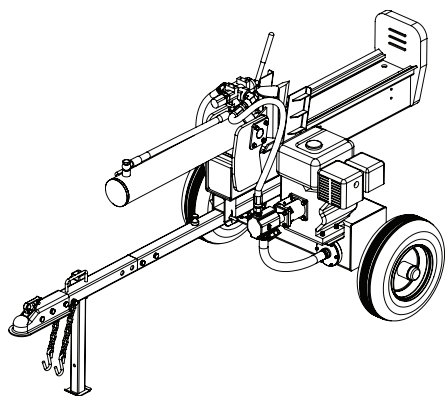

# 22 Ton LOG SPLITTER

## TABLE OF CONTENTS

<b>Introduction</b> . . . . .	<b>1</b>	Maintenance Schedule . . . . .	17
Introduction . . . . .	1	Log Splitter Maintenance . . . . .	17
Portable Log Splitter . . . . .	1	Storage . . . . .	17
Accessories . . . . .	1	Log Splitter Storage . . . . .	17
This Booklet . . . . .	1	Engine stored for Less than 30 Days . . . . .	17
<b>Manual Conventions</b> . . . . .	<b>2</b>	Engines Stored for Over 30 Days . . . . .	17
<b>Safety Rules</b> . . . . .	<b>3</b>	<b>Troubleshooting</b> . . . . .	<b>19</b>
Training . . . . .	5	<b>Specifications</b> . . . . .	<b>20</b>
Preparation . . . . .	5	Log Splitter Specifications . . . . .	20
Operation . . . . .	6	Engine Specifications . . . . .	20
Maintenance and Storage . . . . .	6	Spark Plugs . . . . .	20
<b>Controls and Features</b> . . . . .	<b>7</b>	Maintenance Valve Clearance . . . . .	20
Log Splitter . . . . .	7	Hydraulic Oil . . . . .	20
<b>Assembly</b> . . . . .	<b>8</b>	Fuel . . . . .	20
Open Shipping Crate . . . . .	8	Oil . . . . .	20
1) Install the Tow Bar . . . . .	8	Parts Diagram . . . . .	21
2) Install the Wheels . . . . .	8	Parts List . . . . .	22
3) Install the Beam . . . . .	8	Engine Parts Diagram . . . . .	23
4) Install the Cylinder and Wedge . . . . .	9	Engine Parts List . . . . .	24
5) Install the Oil Filter . . . . .	9	<b>Warranty</b> . . . . .	<b>25</b>
6) Install the Engine and Hoses . . . . .	10	Warranty Qualifications . . . . .	25
Add Hydraulic Oil . . . . .	10	Repair/Replacement Warranty . . . . .	25
Add Engine Oil . . . . .	11	Do Not Return The Unit To	
Add Engine Fuel . . . . .	11	The Place Of Purchase . . . . .	25
<b>Operation</b> . . . . .	<b>12</b>	Warranty Exclusions . . . . .	25
Before Each Use Inspect the Log Splitter . . . . .	12	Normal Wear . . . . .	25
Towing Log Splitter Safety . . . . .	12	Installation, Use and Maintenance . . . . .	25
Log Splitter Location . . . . .	12	Other Exclusions . . . . .	25
Starting the Engine . . . . .	13	Limits of Implied Warranty and Consequential	
Stopping the Engine . . . . .	13	Damage . . . . .	25
Log Splitter Operation . . . . .	14	Contact Information . . . . .	25
<b>Maintenance and Storage</b> . . . . .	<b>15</b>	Address . . . . .	25
Engine Maintenance . . . . .	15	Customer Service . . . . .	25
Oil . . . . .	15	Technical Service . . . . .	25
Spark Plugs . . . . .	15		
Air Filter . . . . .	15		
Changing the Hydraulic Oil and Oil Filter . . . . .	16		
Cleaning . . . . .	17		

# INTRODUCTION

## Introduction

Congratulations on your purchase of a Champion Power Equipment log splitter. CPE designs and builds log splitters to strict specifications. With proper use and maintenance, this log splitter will bring years of satisfying service.

## Portable Log Splitter

This unit is a gasoline engine driven hydraulic log splitter. It is designed to split wood logs for use as firewood for a stove or fireplace. This log splitter will only split logs lengthwise, with the grain only.

## Accessories

Champion Power Equipment manufactures and sells accessories designed to help you get the most from your purchase. To find out more, please visit our website at:  
→ [www.championpowerequipment.com](http://www.championpowerequipment.com)

## This Booklet

Every effort has been made to ensure the accuracy and completeness of the information in this manual. We reserve the right to change, alter and/or improve the product and this document at any time without prior notice.

Record the model and serial numbers as well as date and place of purchase for future reference. Have this information available when ordering parts and when making technical or warranty inquiries.

<b>Champion Power Equipment Support</b>
<b>1-877-338-0999</b>
Model Number
<b>92251-1</b>
Serial Number
Date of Purchase
Purchase Location
For <b>Oil Type</b> see "Add Engine Oil" section. For <b>Fuel Type</b> see "Add Fuel" section.

This manual uses the following symbols to help differentiate between different kinds of information. The safety symbol is used with a key word to alert you to potential hazards in operating and owning power equipment.

Follow all safety messages to avoid or reduce the risk of serious injury or death.

 **DANGER**

DANGER indicates an imminently hazardous situation which, if not avoided, **will** result in death or serious injury.

 **WARNING**

WARNING indicates a potentially hazardous situation which, if not avoided, **could** result in death or serious injury.

 **CAUTION**

CAUTION indicates a potentially hazardous situation which, if not avoided, **may** result in minor or moderate injury.

**CAUTION**

CAUTION used without the safety alert symbol indicates a potentially hazardous situation which, if not avoided, **may** result in property damage.

 **NOTE**

If you have questions regarding your log splitter, we can help. Please call our help line at **1-877-338-0999**

# SAFETY RULES

## WARNING

Read this manual thoroughly before operating your log splitter. Failure to follow instructions could result in serious injury or death.

## WARNING

The engine exhaust from this product contains chemicals known to the state of California to cause cancer, birth defects, or other reproductive harm.

## DANGER

Log Splitter engine exhaust contains carbon monoxide, a colourless, odourless, poison gas. Breathing carbon monoxide will cause nausea, dizziness, fainting or death. If you start to feel dizzy or weak, get to fresh air immediately.

Operate log splitter outdoors only in a well ventilated area. DO NOT operate the log splitter inside any building, enclosure or compartment. DO NOT allow exhaust fumes to enter a confined area through windows, doors, vents or other openings. **DANGER CARBON MONOXIDE**, using a log splitter indoors **CAN KILL YOU IN MINUTES**.

## DANGER

Rotating parts can entangle hands, feet, hair, clothing and/or accessories. Traumatic amputation or severe laceration can result.

Keep hands and feet away from rotating parts. Tie up long hair and remove jewellery. Operate equipment with guards in place. DO NOT wear loose-fitting clothing, dangling drawstrings or items that could become caught.

## DANGER

Sparks can result in fire or electrical shock.

### When servicing the engine:

Disconnect the spark plug wire and place it where it cannot contact the plug. DO NOT check for spark with the plug removed. Use only approved spark plug testers.

## WARNING

Running engines produce heat. Severe burns can occur on contact. Combustible material can catch fire on contact.

DO NOT touch hot surfaces. Avoid contact with hot exhaust gases. Allow equipment to cool before touching. Maintain at least 3 ft. (91.4 cm) of clearance on all sides to ensure adequate cooling. Maintain at least 5 ft. (1.5 m) of clearance from combustible materials.

## WARNING

Crush Hazard

Wedge can cut through skin and break bones. Keep all limbs away from wedge and endplate.

## WARNING

Projectile Hazard

Pieces of log may be ejected from the splitter while operating. **Wear ANSI approved safety glasses when operating. Be alert.**

## WARNING

Keep Operator Work Zone Clear

Keep work zone clear of debris while working to ensure safe footing.

**⚠ DANGER**

Skin Injection Hazard. High pressure hydraulic oil can inject under your skin.

Make sure all fittings are tightly secure before applying pressure. Relieve system of pressure before servicing.

**⚠ WARNING****Towing Hazard**

ALWAYS check all local and state regulations regarding towing, licensing and lights before towing your log splitter. Review towing safety warnings in your towing vehicle manual.

Drive safely. Be aware of the added length of the log splitter. NEVER ride or transport cargo on the log splitter. Choose a level surface to operate the log splitter.

**NEVER EXCEED MAX. Towing Speed 45 MPH (72 KPH)**

**⚠ WARNING**

Rapid retraction of the starter cord will pull hand and arm towards the engine faster than you can let go. Unintentional startup can result in entanglement, traumatic amputation or laceration. Broken bones, fractures, bruises or sprains could result.

When starting engine, pull the starter cord slowly until resistance is felt and then pull rapidly to avoid kickback.

**⚠ CAUTION**

Improper treatment or use of the log splitter can damage it, shorten its life and void your warranty.

Use the log splitter only for intended uses. Operate only on level surfaces. DO NOT expose log splitter to excessive moisture, dust, or dirt.

DO NOT allow any material to block the cooling slots. DO NOT use the engine if:

- Equipment sparks, smokes or emits flames
- Equipment vibrates excessively

**⚠ DANGER**

Fuel and fuel vapours are highly flammable and extremely explosive.

Fire or explosion can cause severe burns or death. Unintentional startup can result in entanglement, traumatic amputation or laceration.

**When adding or removing fuel:**

Turn the engine off and let it cool for at least two minutes before removing the fuel cap. Loosen the cap slowly to relieve pressure in the tank.

Only fill or drain fuel outdoors in a well-ventilated area.

DO NOT pump gas directly into the log splitter at the gas station. Use an approved container to transfer the fuel to the log splitter.

DO NOT overfill the fuel tank.

Always keep fuel away from sparks, open flames, pilot lights, heat and other sources of ignition.

DO NOT light or smoke cigarettes.

**When starting the engine:**

DO NOT attempt to start a damaged engine.

Make certain that the gas cap, air filter, spark plug, fuel lines and exhaust system are properly in place.

Allow spilled fuel to evaporate fully before attempting to start the engine.

Make certain that the log splitter is resting firmly on level ground.

**When operating the log splitter:**

DO NOT move or tip the log splitter during operation.

DO NOT tip the log splitter or allow fuel or oil to spill.

Block the tires to prevent unintended movement.

**When transporting or servicing the log splitter:**

Make certain that the fuel shutoff valve is in the off position and the fuel tank is empty.

Disconnect the spark plug wire.

**When storing the log splitter:**

Store away from sparks, open flames, pilot lights, heat and other sources of ignition.

**⚠ CAUTION**

Parts of the hydraulic circuit (cylinder, pump, valve-body, hoses) can become very hot during operation.

# SAFETY RULES

## Training

1. Read the Operator's Manual completely before attempting to use this log splitter.
2. Do not allow anyone to operate your log splitter who has not read the Operator's Manual or has not been instructed on the safe use of the log splitter.
3. Never allow children or untrained adults to operate this machine.
4. Many accidents occur when more than one (1) person operates the log splitter. If a helper is assisting in loading logs to be split, never actuate controls until helper is clear of the area.
5. Never allow anyone to ride on the machine.
6. Never transport cargo on the log splitter.
7. High fluid pressures are developed in hydraulic log splitters. Pressurized hydraulic fluid escaping through a pin hole opening can puncture skin and cause sever blood poisoning. Therefore, the following instructions should be heeded at all times.
  - a. Do not operate the unit with frayed, kinked, cracked or damaged hoses, fittings, or tubing.
  - b. Stop the engine and relieve hydraulic system pressure before changing or adjusting fittings, hoses, tubing, or other system components.
  - c. Do not adjust the pressure settings of the pump or valve.
  - d. Do not check for leaks with your hand. Leaks can be detected by passing cardboard or wood over the suspected area. Look for discolouration. If injured by escaping fluid, see a doctor at once. Serious infection or reaction can develop if proper medical treatment is not administered immediately.
8. Keep the operator zone and adjacent area clear for safe, secure footing.
9. If your log splitter is equipped with an internal-combustion engine and intended for use near any unimproved forest, brush, or grass covered land, the engine exhaust should be equipped with a spark arrestor. Make sure you comply with local, state, and federal codes. Take appropriate fire-fighting equipment with you.
10. Log splitters should be used only for splitting wood. Do not use for other purposes unless the manufacturer provides attachments and instructions.

## Preparation

1. Be thoroughly familiar with all controls and with proper use of the equipment.
2. Safety Gear:
  - a. Always wear safety shoes or heavy boots when operating the machine.
  - b. Always wear safety glasses or goggles when operating the machine.
  - c. Never wear jewelry or loose-fitting clothing that might become entangled in moving or rotating parts of the machine.
3. Make sure the splitter is on a level surface. Block tires and ensure support leg is secure to prevent unintended movement of the log splitter during operation.
  - a. Always operate the splitter from the manufacturer's indicated operator zone.
4. Logs to be split on ram-type units should be cut as squarely as possible.
5. Fuel:
  - a. Use an approved fuel container.
  - b. Never add fuel to a running or hot engine.
  - c. Fill fuel tank outdoors with extreme care. Never fill fuel tank indoors.
  - d. Replace gasoline cap securely and clean up any spilled fuel.



## Operation

1. Before starting this log splitter, review all safety rules. Failure to follow these rules may result in serious injury to the operator or bystanders.
2. Be sure to confirm all hose connections and hose clamps are tight before each use. It is possible for connections to vibrate loose over time.
3. Never leave the machine unattended with the power source operating.
4. Never operate the machine when under the influence of alcohol, drugs or medication.
5. The machine owner should instruct all operators in safe log splitter operation.
6. Always operate the log splitter with all safety equipment in place and all controls properly adjusted for safe operation.
7. Always operate the log splitter at manufacturer's recommended speed.
8. Always keep hands and feet clear of moving parts.
9. When loading a ram-type log splitter, place your hands on the sides of the log, not the ends. Never place your hands or any part of your body between a log and any part of the log splitter.
  - a. On ram-type log splitters, never attempt to split more than one (1) log at a time unless the ram has been fully extended and a second log is needed to complete the separation of the first log.
10. On ram-type log splitters on which the logs are not cut square, the longest portion of the log should be rotated down and the most square end placed against the ram.
11. Use only your hand to operate the log splitter controls.
12. Do not refuel the engine until it has cooled for several minutes.

## Maintenance and Storage

1. Always shut off the power source while repairing or adjusting the splitter except as recommended by the manufacturer.
2. Clean debris and chaff from the engine cylinder, cylinder head fins, blower house rotation screen, and muffler areas. If the engine is equipped with a spark arrestor muffler, clean and inspect it regularly (follow manufacturer's service instructions). Replace, if damaged.
3. Never store the unit indoors with fuel in the tank. Fumes might reach an open flame spark. Allow the engine to cool before storing in any enclosure.
4. Clear debris from moveable parts, but only when the power source is shut off.
5. Check to be sure all nuts and bolts are tight to assure the equipment is in safe working condition.

# CONTROLS AND FEATURES

Read this owner's manual before operating your log splitter. Familiarize yourself with the location and function of the controls and features. Save this manual for future reference.

## Log Splitter

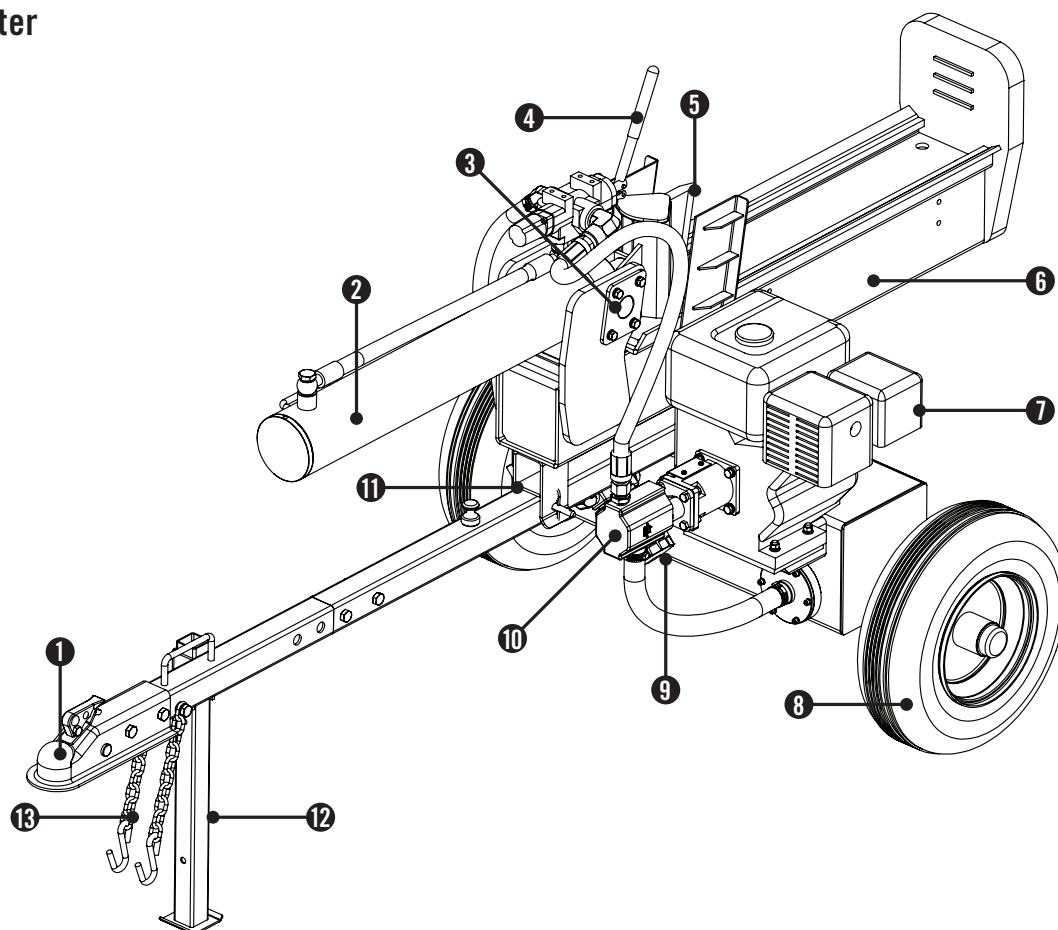

- |   |  |
|---|--|
| <p>(1) <b>2 in. (5.1 cm) Ball Coupler</b> – For towing the log splitter behind your vehicle.</p> <p>(2) <b>Hydraulic Cylinder</b> – 4 in. (10.2 cm) bore x 22.6 in. (57.5 cm) stroke. Rated to 3500 psi.</p> <p>(3) <b>Mounting Plates</b> – Holds hydraulic cylinder in place.</p> <p>(4) <b>Control Valve Handle</b> – Controls the movement of the cutting wedge.</p> <p>(5) <b>Wedge</b></p> <p>(6) <b>Splitting Beam</b></p> | <p>(7) <b>Engine</b> – 208cc, OHV, 4-stroke, air cooled.</p> <p>(8) <b>Tires</b> – Maximum travel speed is 45 MPH (72 KPH).</p> <p>(9) <b>Hydraulic Fluid Filter</b></p> <p>(10) <b>Hydraulic Pump</b> – Pumps hydraulic oil through the system.</p> <p>(11) <b>Beam Bracket</b> – Holds splitting beam in place.</p> <p>(12) <b>Support Leg</b> – Supports log splitter while operating. Raise leg for towing.</p> <p>(13) <b>Safety Chains</b> – For use while towing.</p> |
|---|--|

Your log splitter requires some assembly. If you have any questions regarding the assembly of your log splitter, call our help line at 1-877-338-0999. Please have your serial number and model number available.

## Open Shipping Crate

1. Set the shipping crate on a solid, flat surface
2. Carefully cut the shipping bands and remove lid of shipping crate.
3. Locate all hardware before beginning assembly.

## 1) Install the Tow Bar

1. Assemble two piece tow bar with two M12x65 bolts and M12 lock nuts and washers. (A)

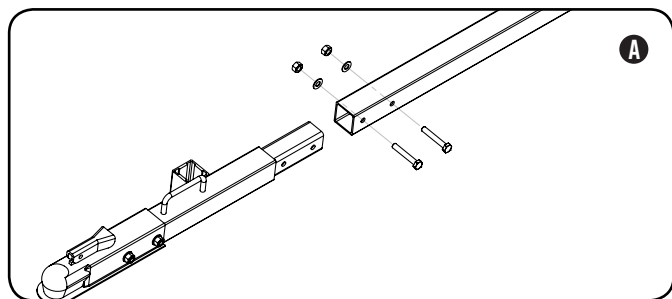

2. Attach the tow bar to the bracket on top of the hydraulic oil tank with two M12x85 bolts and M12 lock nuts. (B)

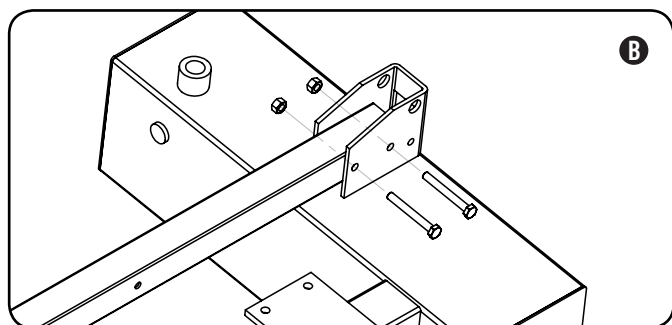

## 2) Install the Wheels

1. Place bearings in the wheel hub
2. Press the seal over the bearing on the inside of the wheel. Use a hammer and wood block to flush the seal with the end of the hub.
3. Slide the wheel over the axle on the hydraulic oil tank.
4. Install the castle nut and tighten by hand. Tighten another 1/4 turn with a wrench to seat the bearing.
5. Spin the wheel to distribute grease.
6. Loosen the castle nut and re-tighten by hand.
7. Install the cotter pin through the castle nut and axle to prevent the nut from backing off.
8. Place axle cap over castle nut and axle.
9. Repeat steps 1-8 for the other wheel.

## 2) Install the Wheels Cont'd.

### NOTE

Keep the wheel hub clean and free from debris during assembly.

### CAUTION

Over-tightening the castle nut will cause the bearings to run hot and fail prematurely.

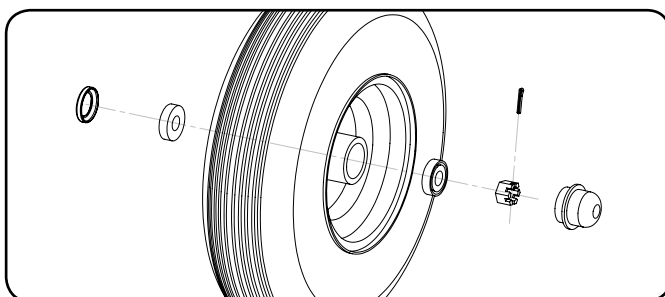

## 3) Install the Beam

1. Install the front support leg and secure with pin and R-pin (hairpin clip). (A)

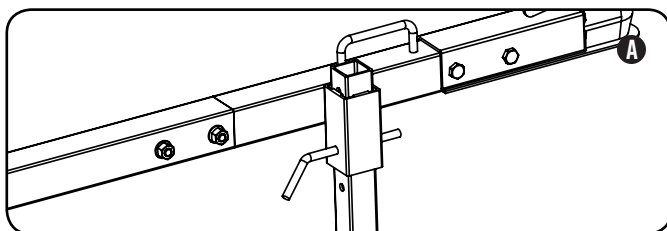

2. Stand the beam upright on foot plate behind the hydraulic fluid tank. (B)

### ! CAUTION

Beam is heavy. Use at least 2 people when lifting or moving the beam.

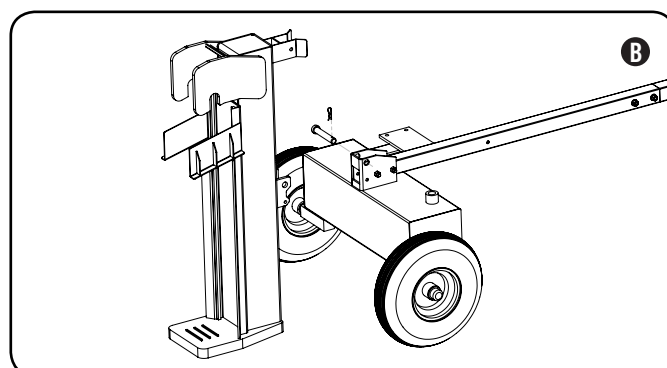

## ASSEMBLY

### 3) Install the Beam Cont'd.

3. Slowly lift the front of the tow bar to roll the frame toward the beam and carefully align the pivot holes on the bottom of the beam and the top of the hydraulic oil tank.
4. Once aligned, secure the beam to the tank with hitch pin and R-pin. (C)

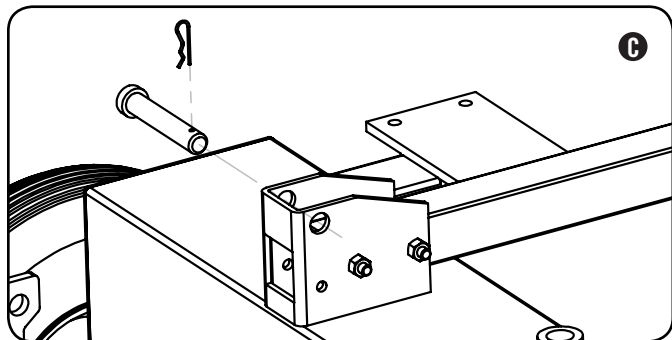

5. Hold the top of the beam by the cylinder mount and carefully rotate the beam toward the tow bar.
6. Once the bracket on the bottom of the beam is aligned with the tow bar, secure with pin and R-pin. (D)

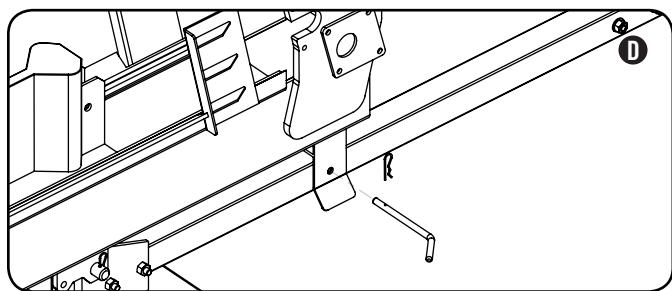

### 4) Install the Cylinder and Wedge

1. Place the wedge on the beam between the cylinder mounts and slide it forward into the rails. (A)
2. Remove the cylinder mounting plates. (A)

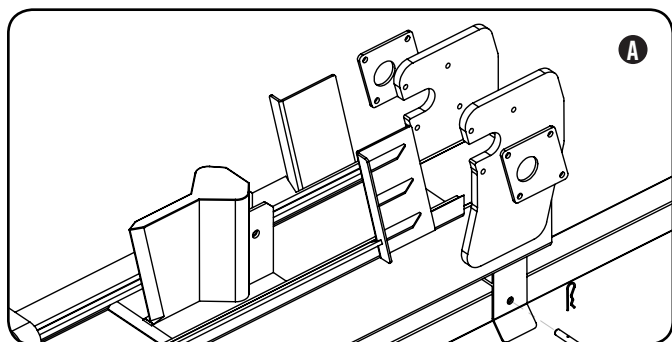

3. Install the cylinder by sliding the pegs at the end of the cylinder into the mounting slots on top of the beam. Be sure to slide the cylinder all the way back into the mounting slots. (B)

### 4) Install the Cylinder and Wedge Cont'd.

#### NOTE

The cylinder will support itself when slid all the way back into the mounting slots.

4. Secure the cylinder mounting plates with hardware removed in step 2. (B)
5. Slide the wedge back toward the cylinder and align the bolt hole in the wedge with the bolt hole in the cylinder rod. (B)

#### NOTE

The cylinder rod may need to be rotated slightly in order to properly align the the wedge. Insert a screwdriver into the bolt hole in the cylinder rod and slowly rotate as needed.

6. Secure the wedge to the cylinder rod with an M12x75 bolt and M12 nut. Lightly tighten the nut to approximately 5 ft-lb. (B)

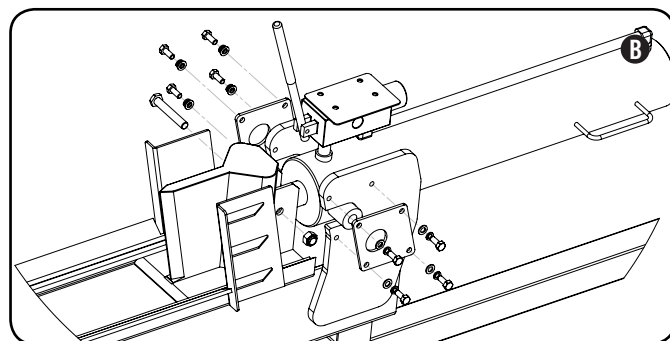

### 5) Install the Oil Filter

1. Remove the oil filter from the oil filter base.
2. Install the oil filter base onto the hydraulic oil tank. The barb fitting should be oriented vertically and once installed the oil filter should be oriented so that it does not extend below the hydraulic oil tank.
3. Lightly lubricate the filter seal with oil.
4. Install the oil filter onto the oil filter base. Tighten  $\frac{3}{4}$ -1 turn once the oil filter seal contacts the oil filter base.

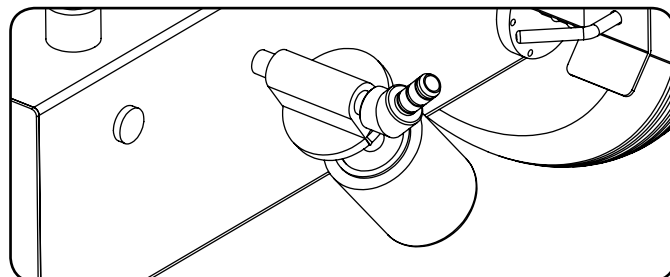

5. Install the hose retaining ring to the side of the splitting beam.

## 6) Install the Engine and Hoses

1. Attach the engine/pump to the engine mounting plate on the hydraulic oil tank. (A)
2. Place O-ring into the outlet fitting on the top of the pump. (A)

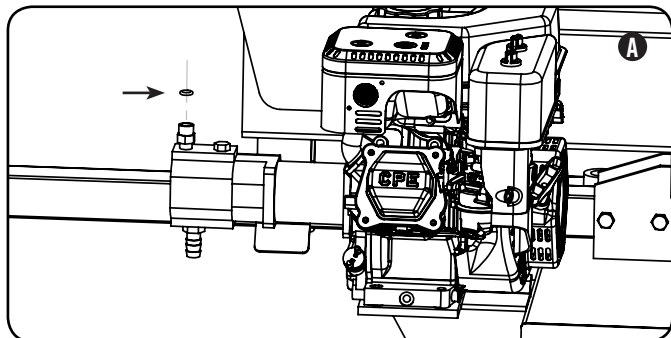

3. Connect one end of the high pressure hose to the pump outlet fitting and the other end to the inlet on the control valve. (B)

### NOTE

The swivel nut end of the high pressure hose connects to the pump outlet.

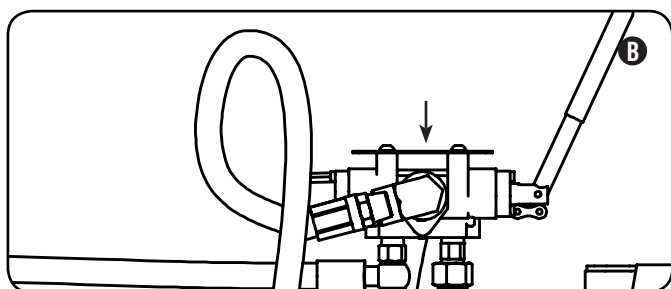

4. Connect one end of the clear oil hose to the hydraulic oil tank just beneath the engine and the other end to the pump inlet on the bottom of the pump. (C)

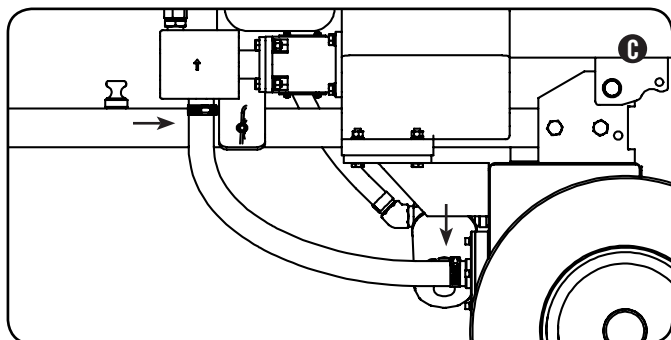

5. Connect one end of the oil return hose to the outlet barb fitting on the control valve and the other end to the barb fitting on the oil filter. (D)

## 6) Install the Engine and Hoses Cont'd.

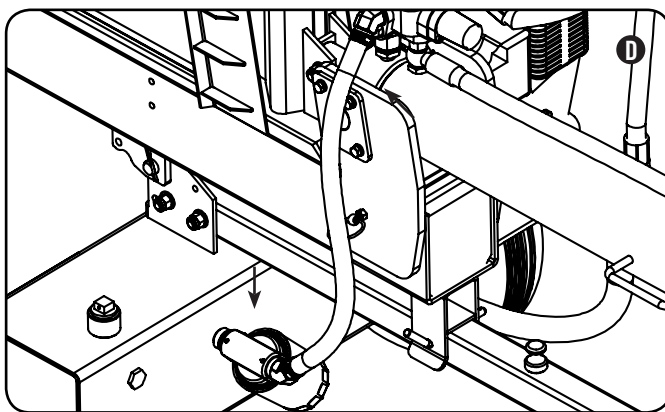

## Add Hydraulic Oil

1. Make sure the log splitter is on a flat, level surface.
2. Remove the oil plug from the oil tank. (A)
3. Add 5 gallons (18.9 L) of hydraulic oil - 10W AW32, ASLE H-150, or ISO 32 are all acceptable types of fluid.
4. Check the hydraulic oil level using the oil sight glass. Oil level should visibly fill the glass sight. (B)
5. Replace and tighten the oil plug and orient the vent

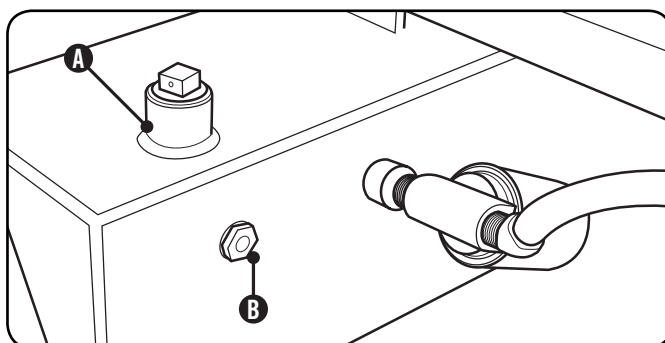

### WARNING

DO NOT remove the hydraulic oil fill cap when the engine is running or hot. Hot oil can escape causing severe burns. Always allow the log splitter to cool completely before removing the hydraulic oil cap. High fluid pressure and temperatures are created in the hydraulic log splitters. Hydraulic fluid will escape through a pin-size hole opening and can puncture skin and cause severe blood poisoning. Inspect hydraulic system regularly for possible leaks. Never check for leaks with your hand while the system is pressurized. Seek medical attention immediately if injured by escaping fluid.

### NOTE

When temperature is below 0°C (32°F) use universal tractor/transmission fluid.

# ASSEMBLY

## Add Hydraulic Oil Cont'd.

hole away from the operator zone.

- Start Engine. Extend and retract the wedge to purge air from the hydraulic system. When the wedge motion is smooth, the system is properly purged.
- Check the hydraulic oil tank sight glass. Add approximately 1 to 1.5 gallons (3.8 to 5.7 L) of hydraulic oil to bring the level back up to the sight glass.
- Check oil level daily and add as needed.

## Add Engine Oil

### ! CAUTION

DO NOT attempt to crank or start the engine before it has been properly filled with the recommended type and amount of oil. Damage to the log splitter as a result of failure to follow these instructions will void your warranty.

- Make sure the log splitter is on a flat, level surface.
- Remove oil fill cap/dipstick to add oil.
- Add up to 0.6 qt. (0.6 L) of oil and replace oil fill cap/dipstick. DO NOT OVERFILL.
- Check engine oil level daily and add as needed.

### CAUTION

The engine is equipped with a low oil shut-off and the will stop when the oil level in the crankcase falls below the threshold level.

### NOTE

Check oil often during the break-in period. Refer to the Maintenance section for recommended service intervals.

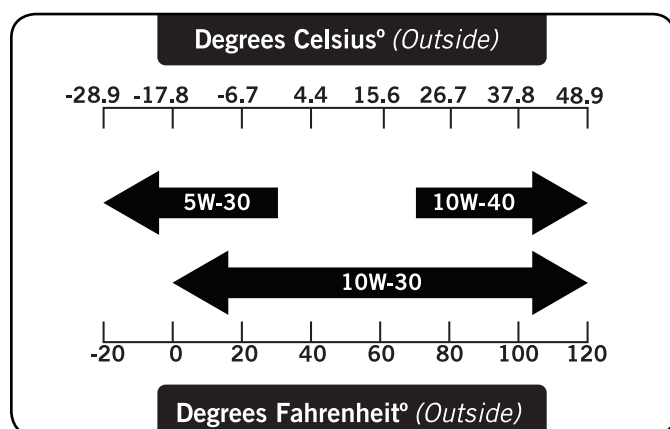

## Add Engine Fuel

- Use clean, fresh, regular unleaded fuel with a minimum octane rating of 85 and an ethanol content of less than 10% by volume.
- DO NOT mix oil with fuel.
- Clean the area around the fuel cap.
- Remove the fuel cap.
- Slowly add fuel to the tank. DO NOT OVERFILL. Fuel can expand after filling. A minimum of ¼ in. (6.4 mm) of space left in the tank is required for fuel expansion, more than ¼ in. (6.4 mm) is recommended. Fuel can be forced out of the tank as a result of expansion if it is overfilled, and can affect the stable running condition of the product. When filling the tank, it is recommended to leave enough space for the fuel to expand.
- Screw on the fuel cap and wipe away any spilled fuel.

### ! CAUTION

Use regular unleaded gasoline with a minimum octane rating of 85.

Do not mix oil and gasoline.

Fill tank to approximately ¼ in. (6.4 mm) below the top of the tank to allow for fuel expansion.

DO NOT pump gas directly into the engine at the gas station. Use an approved container to transfer the fuel to the engine.

DO NOT fill fuel tank indoors.

DO NOT fill fuel tank when the engine is running or hot.

DO NOT overfill the fuel tank.

DO NOT light cigarettes or smoke when filling the fuel tank.

### ! WARNING

Pouring fuel too fast through the fuel screen may result in blow back of fuel at the operator while filling.

### NOTE

Our engines work well with 10% or less ethanol blend fuels. When using blended fuels there are some issues worth noting:

- Ethanol-gasoline blends can absorb more water than gasoline alone.
- These blends can eventually separate, leaving water or a watery goo in the tank, fuel valve and carburetor.
- With gravity-fed fuel supplies, this compromised fuel can be drawn into the carburetor and cause damage to the engine and/or potential hazards.
- There are only a few suppliers of fuel stabilizer that are formulated to work with ethanol blend fuels.
- Any damages or hazards caused by using improper fuel, improperly stored fuel, and/or improperly formulated stabilizers, are not covered by manufacture's warranty.

It is advisable to always shut off the fuel supply, run the engine to fuel starvation and drain the tank when the equipment is not in use for more than 30 days.



## Before Each Use Inspect the Log Splitter

1. Check the hydraulic oil level and visually inspect all hoses, attachments and cylinder for loose fittings, leaks, cracks, fraying or other damage.
2. DO NOT operate the log splitter if there is any indication of damage.
3. Inspect the engine and make sure the oil level is correct before operating. If the engine is equipped with a spark arrestor, clean and inspect it regularly (follow spark arrestor maintenance schedule).
4. The tires need to be fully inflated and in good repair. Reference the tire sidewall for recommended tire pressure.

### WARNING

DO NOT over inflate tires. Serious injury can result if tires explode.  
DO NOT tow the log splitter if the tires are worn or will not hold air.  
DO NOT exceed the maximum 45 MPH (72 KPH) towing speed.

## Towing Log Splitter Safety

1. Always check local and state regulations regarding the requirements for towing, licensing and lights.
2. Before towing make sure the log splitter is correctly and securely attached to the vehicle and the safety chains attached with enough slack to allow for turning.
3. Never exceed the max. travel speed of 45 mph (72 kph). Towing the log splitter at speeds greater than 45 mph (72 kph) could result in serious injury or death. Always adjust your towing speed according to the terrain and conditions.
4. Always disconnect the log splitter from the towing vehicle before operating.

## Log Splitter Location

This log splitter must have at least seven feet of clearance from combustible material. Leave at least three feet of clearance on all sides of the log splitter to allow for adequate cooling, maintenance and servicing. DO NOT place the log splitter near vents or intakes where engine exhaust fumes could be drawn into occupied or confined spaces. **Always operate the log splitter outdoors.**

The log splitter needs to be on a dry level surface with good footing. DO NOT work on mud, ice, tall grass, brush or snow.

Only operate log splitter from work zone shown below.

## Log Splitter Location Cont'd.

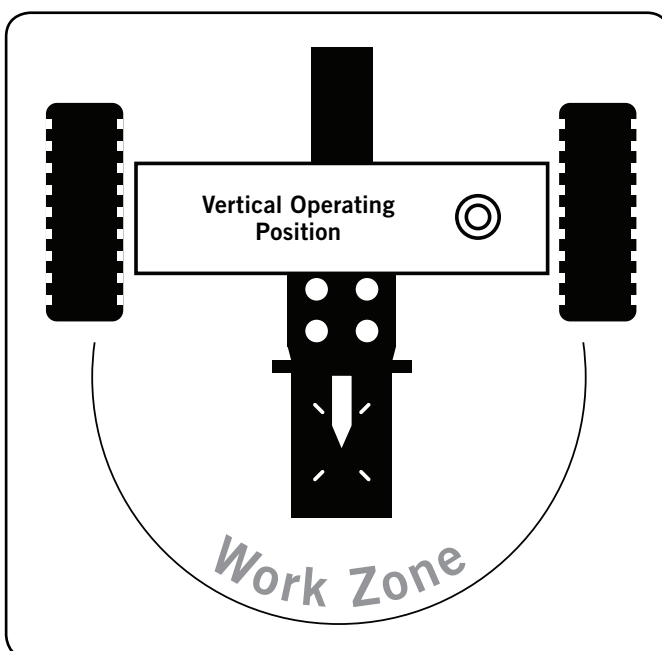
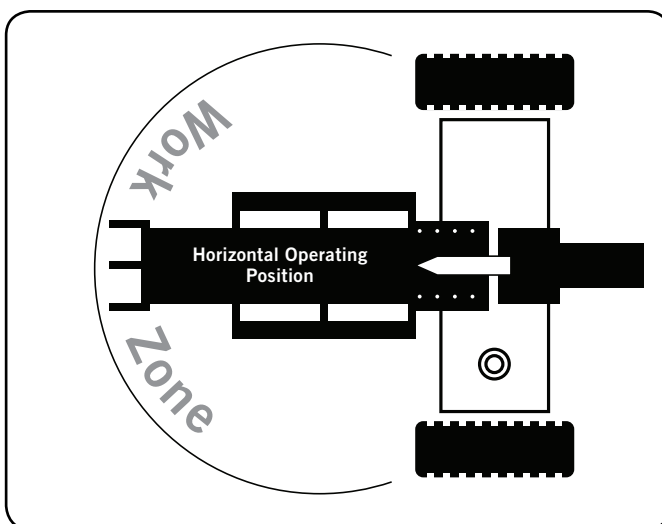

# OPERATION

## Log Splitter Location Cont'd.

### WARNING

ALWAYS use the log splitter for its intended use. The log splitter should only be used to split wood logs, length wise with the grain.

NEVER modify, alter or change the log splitter in anyway. Modifications will void the warranty.

NEVER attach a rope, cable or other device to the control lever on the log splitter.

DO NOT modify or change the engine and operating speeds or pressure settings. These changes can cause safety issues.

ONLY operate the log splitter in daylight.

NEVER operate, or let anyone else operate, the log splitter while under the influence of alcohol, drugs, or medication.

NEVER leave the log splitter unattended while the engine is running.

DO NOT change the splitting position with the engine running. Contact with the muffler can cause serious burns.

Always make sure the beam is in the locked position.

DO NOT let the beam drop as it could crush fingers or cause damage to the log splitter.

## Starting the Engine

1. Make certain the log splitter is on a flat, level surface.
2. Turn engine switch to "ON" position.
3. Turn the fuel valve to the "ON" position.
4. Move the choke lever to the "Choke" position.
5. Pull the starter cord slowly until resistance is felt and then pull rapidly. **SEE NOTE BELOW.**

### NOTE

Keep choke lever in "Choke" position for only 1 pull of the recoil starter. After first pull, move choke lever to the "Run" position for up to the next 3 pulls of the recoil starter. Too much choke leads to spark plug fouling/engine flooding due to the lack of incoming air. This will cause the engine not to start.

6. As engine warms up, move the choke lever to "Run."
7. Move the throttle lever to the "Fast" position.

## Starting the Engine Cont'd.

### NOTE

If the engine starts, but does not run, make certain that the log splitter is on a flat, level surface. The engine is equipped with a low oil sensor that will prevent the engine from running when the oil level falls below a critical threshold.

The hydraulic oil needs to be above -12°C (10°F) before starting the engine. Cold hydraulic oil can damage the hydraulic pump.

If outdoor air temperature is below 0°C (32°F) allow the log splitter to warm up by extending and returning the wedge several times before splitting wood.

## Stopping the Engine

1. Turn the fuel knob to the "Off" position.
2. Let the engine run until fuel starvation has stopped the engine. This usually takes a few minutes.
3. Turn the engine switch to the "Off" position.

**Important:** Always ensure that the Fuel Valve and the Engine Switch are in the "OFF" position when the engine is not in use.

### NOTE

If the engine will not be used for a period of two (2) weeks or longer, please see the Storage section for proper engine and fuel storage.



## Log Splitter Operation

1. ALWAYS wear ear and eye protection, protective clothing and safety gear.

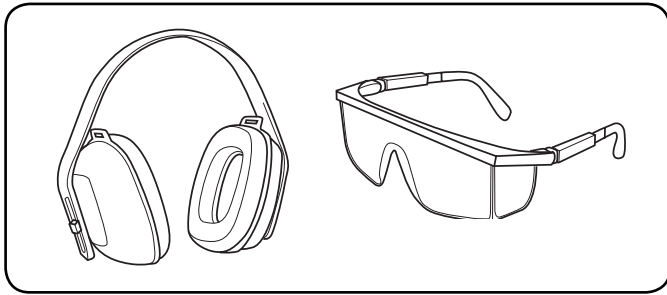

2. Block tires and put both support legs in the DOWN position to prevent unintended movement of the log splitter during operation.
3. Set log splitter in either the horizontal or vertical position.

### NOTE

HORIZONTAL position is used for lighter logs that can easily be loaded onto the beam.

VERTICAL position is used for light logs as well as heavy logs that are difficult to load onto the beam.

Back injury can result from lifting logs onto the log splitter if proper lifting techniques are not used.

4. Load a log onto the beam against the end plate (MAX LOG LENGTH – 23.8 in. (60.3 cm))
5. Make sure all limbs are clear of crush zones.
6. Push the control valve handle forward (towards the end plate) to split the log.
7. Push the auto control valve handle backward to return the wedge to its original position.
8. Clear the split wood from the work zone.

### CAUTION

Do not hold auto control valve in return position. It will damage the stop block or beam.

### NOTE

It is normal for the hydraulic fluid to become foamy or frothy during operation.

# MAINTENANCE AND STORAGE

The owner/operator is responsible for all periodic maintenance.

## WARNING

Never operate a damaged or defective log splitter.

## WARNING

Improper maintenance will void your warranty.

## NOTE

For service or parts assistance, contact our help line at **1-877-338-0999**.

Complete all scheduled maintenance in a timely manner. Correct any issue before operating the log splitter.

## Engine Maintenance

To prevent accidental starting, remove and ground spark plug wire before performing any service.

### Oil

Change oil when the engine is warm. Refer to the oil specification to select the proper grade of oil for your operating environment.

1. Remove the oil drain plug with a 10 mm socket and extension.
2. Allow the oil to drain completely.
3. Replace the drain plug.
4. Remove oil fill cap/dipstick to add oil.
5. Add 0.6 qt. (0.6 L) of oil and replace oil fill cap/dipstick. **DO NOT OVERFILL.**
6. Dispose of used oil at an approved waste management facility.

## NOTE

Once oil has been added, use the dipstick to check oil level, **DO NOT** screw in the dipstick while checking.

## WARNING

Used oil is a hazardous waste product and must be disposed of properly. Do not discard with household waste. Check with your local authorities, service center, or dealer for safe disposal/recycling facilities.

### Oil Cont'd.

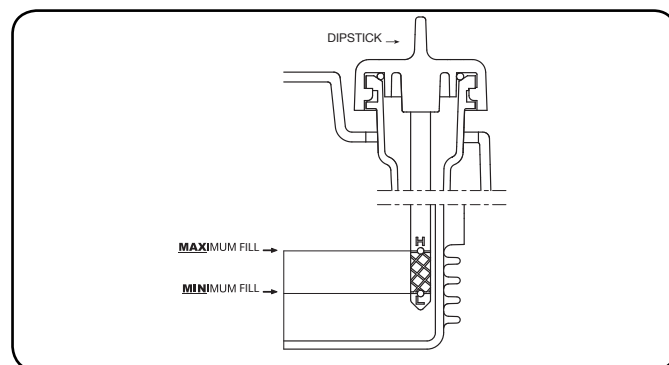

### Spark Plugs

1. Remove the spark plug cable from the spark plug.
2. Inspect the electrode on the plug. It must be clean and not worn to produce the spark required for ignition.
3. Make certain the spark plug gap is 0.6 - 0.8 mm (0.024 - 0.031 in.).

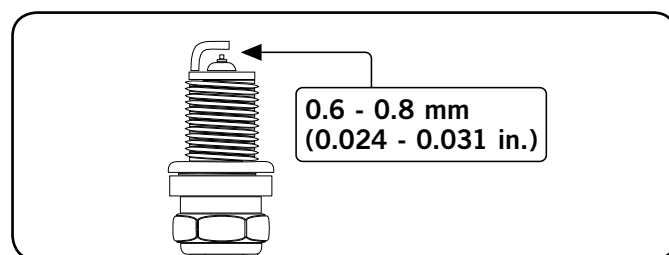

4. Refer to the spark plug recommendation chart when replacing the plug.
5. Carefully thread the plug into the engine.
6. Use the spark plug tool to firmly install the plug.
7. Attach the spark plug wire to the plug.

### Air Filter

1. Using your fingers, press and slide the top of the air filter housing to remove.
2. Remove the plastic outer casing.
3. Remove the foam element.
4. Wash in liquid detergent and water. Squeeze thoroughly dry in a clean cloth.
5. Saturate in clean engine oil.
6. Squeeze in a clean, absorbent cloth to remove all excess oil.
7. Place the filter in the assembly.
8. Reattach the air filter cover.

## Changing the Hydraulic Oil and Oil Filter

### NOTE

Install a new hydraulic oil filter each time the hydraulic oil is changed

1. Begin with the cylinder retracted and the engine "OFF."
2. Turn the fuel valve "OFF."
3. Release any stored pressure by moving the valve lever forward and backward several times.
4. Place a container under the hydraulic tank. Make sure it is large enough to hold the contents of the tank.
5. To drain the oil, unscrew and remove the tank drain plug on the bottom of the hydraulic tank.
  - a. Unscrew and remove the hydraulic oil filter.
  - b. Drain any oil in the filter into the container.
6. Allow oil to completely drain from the tank into the container.
7. Install a new hydraulic oil filter. (A)
  - a. Turn the filter counter-clockwise to remove it. A strap wrench may be used.
  - b. Lubricate the gasket of the new filter with a thin film of clean oil.
  - c. Screw the new filter on clockwise. Tighten  $\frac{3}{4}$  to 1 turn after the gasket makes contact.
8. Reinsert and screw in the tank drain plug. Tighten, but do not over tighten.

### NOTE

The drain plug is sealed with Teflon tape. Add 2-3 wraps of new Teflon tape as needed when replacing the drain plug to prevent oil leak

9. Unscrew and remove the tank fill plug, on top of the tank. Using a funnel add approximately 5 gallons (18.9 L) of hydraulic oil to the tank. Wipe up any spilled oil. (B)

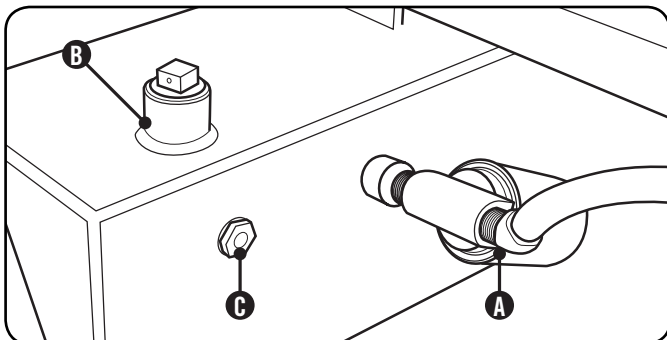

## Changing the Hydraulic Oil and Oil Filter Cont'd.

10. Turn the fuel valve on, and start the engine. Purge the air from the system by extending and retracting the wedge several times until the motion is smooth.
11. Check the hydraulic oil level using the sight glass. Add 1 to 1.5 gallons (3.8 to 5.7 L) of hydraulic oil, so the oil level is visible in the sight glass. (C)
12. Dispose of used oil at approved recycling locations.

### WARNING

Always shut off the engine, disconnect the spark plug, and relieve system pressure before cleaning, adjusting, or repairing the splitter. Relieve system pressure by moving split control lever back and forth several times

### NOTE

Change the hydraulic oil filter after the first 50 hours of use. Then every 100 hours or seasonally.

### NOTE

Replacement filters can be purchased from Champion Power Equipment by calling 1-877-338-0999. Wix #51391 or Fram PH3682 can also be used if needed.

# MAINTENANCE AND STORAGE

## Cleaning

### ⚠ CAUTION

DO NOT use a garden hose to clean the engine or log splitter.

Water can contaminate the fuel system and can enter the engine through the cooling slots and damage the engine.

Clear the debris from the beam, wedge and endplate. Use a damp cloth to clean exterior surfaces of the engine and log splitter.

Use a soft bristle brush to remove excess dirt and oil. Use an air compressor (25 PSI) to clear dirt and small debris. Wipe all metal parts with an oily rag to help prevent rust and corrosion.

## Maintenance Schedule

Follow the service intervals indicated in the schedule below. Service your log splitter more frequently when operating in adverse conditions. Contact our help line at **1-877-338-0999** to locate the nearest Champion Power Equipment authorized service dealer for your log splitter or engine maintenance needs.

Every time of use or daily	
	Check engine and hydraulic oil levels
	Clean around air intake and muffler
	Check air filter
First 5 Hours	
	Change engine oil
Every 25 Hours or per 1 month	
	Change engine oil
	Clean air filter
Every 50 hours or per 6 months	
	Clean and adjust spark plug
	Check cooling fan
Every 100 hours or per 1 year	
	Check/adjust maximum load speed*
	Check/adjust valve clearance*
	Clean fuel tank and filter*
	Change hydraulic oil
	Change hydraulic oil filter
Every year	
	Inspect wheel bearings and repack bearing grease as needed.
Every 200 hours	
	Clean combustion chamber
Every 200 hours or per 2 years	
	Check/replace fuel line
	Change spark plug

\*To be performed by knowledgeable, experienced owners or Champion Power Equipment certified dealers.

## Log Splitter Maintenance

Make certain that the log splitter is kept clean and stored properly. Only operate the unit on a flat, level surface in a clean, dry operating environment. DO NOT expose the unit to extreme conditions, excessive dust, dirt, moisture or corrosive vapours.

Inspect all air vents and cooling slots to ensure that they are clean and unobstructed.

Clean spark arrester every 100 hours.

Check and tighten all bolts and nuts before operating the log splitter.

## Storage

Refer to the Maintenance section for proper cleaning instructions.

### Log Splitter Storage

1. The log splitter needs to be cool for at least 5 minutes before storing.
2. Clean the log splitter before storage according to the Maintenance section.
3. Retract the wedge to protect the rod from corrosion.
4. Wipe the beam and wedge with an oily rag to prevent rust and corrosion.

### Engine stored for Less than 30 Days

1. Allow the engine to cool completely before storage.
2. Clean engine according to the Maintenance section.
3. To extend the fuel storage life add fuel stabilizer.
4. Turn the fuel valve to the "Off" position.

### Engines Stored for Over 30 Days

1. Run the engine with the fuel valve in the "Off" position until the engine stops.
2. The engine needs to cool completely before storage.
3. Clean engine according to the Maintenance section.
4. Drain all fuel completely from the fuel line and carburetor to prevent gum from forming.
5. Add a fuel stabilizer into the fuel tank.
6. Change the oil.
7. The fuel valve needs to be in the off position.
8. Remove the spark plug and pour about 14.8 mL (1/2 oz.) of oil into the cylinder. Crank the engine slowly to distribute the oil and lubricate the cylinder.
9. Reattach the spark plug.

## Log Splitter Storage Cont'd.

 **WARNING**

Never store the log splitter inside next to appliances where there is a source of heat or open flame, spark or pilot light because they can ignite gasoline vapours. DO NOT store a log splitter near fertilizer or any corrosive material. Even with an empty gas tank, gasoline vapours could ignite.

 **NOTE**

Our engines work well with 10% or less ethanol blend fuels. When using blended fuels there are some issues worth noting:

- Ethanol-gasoline blends can absorb more water than gasoline alone.
- These blends can eventually separate, leaving water or a watery goo in the tank, fuel valve and carburetor.
- With gravity-fed fuel supplies, this compromised fuel can be drawn into the carburetor and cause damage to the engine and/or potential hazards.
- There are only a few suppliers of fuel stabilizer that are formulated to work with ethanol blend fuels.
- Any damages or hazards caused by using improper fuel, improperly stored fuel, and/or improperly formulated stabilizers, are not covered by manufacture's warranty.

It is advisable to always shut off the fuel supply, run the engine to fuel starvation and drain the tank when the equipment is not in use for more than 30 days.

# TROUBLESHOOTING

Problem	Cause	Solution
Engine will not start	No fuel	Add fuel
	Faulty spark plug	Replace spark plug
	Unit loaded during startup	Remove load from unit
Engine starts but runs roughly	Low oil level	Fill crankcase to the proper level Place log splitter on a flat, level surface
	Choke in the wrong position	Adjust choke
	Spark plug wire loose	Attach wire to spark plug
Engine shuts down during operation	Out of fuel	Fill fuel tank
	Low oil level	Fill crankcase to the proper level Place log splitter on a flat, level surface
Engine cannot supply enough power or overheating	Insufficient ventilation	Check for air restriction. Move to a well ventilated area
Wedge movement is slow or erratic	Air in the hydraulic oil system	Purge air by extending and retracting the wedge several times until motion is smooth
	Debris lodged in beam guides	Clear debris from beam
	Low hydraulic oil	Check oil level and add as needed
Oil leak from hose connection	Loose hose clamp or hydraulic fitting	Tighten hose clamp or hydraulic fitting
Oil leak from cylinder	Faulty cylinder rod seal	Contact Customer Service
	Scored or bent cylinder rod	Contact Customer Service
	Loose hydraulic fitting	Tighten hydraulic fitting
	Faulty combination washer seal on cylinder hydraulic fitting	Contact Customer Service
Wedge will not extend or retract	Faulty control valve	Contact Customer Service
	Faulty hydraulic pump	Contact Customer Service
	Low hydraulic oil	Check oil level and add as needed
Wedge does not Auto-Return	Low hydraulic oil	Check oil level and add as needed
	Faulty control valve	Contact Customer Service
Excessive bouncing while towing	Under-inflated tires	Inflate tires to proper pressure. Refer to tire sidewall

## For further technical support:

### Technical Service

Mon – Fri 8:30 AM – 5:00 PM (PST/PDT)

Toll Free: 1-877-338-0999

tech@championpowerequipment.com

**Log Splitter Specifications**

- Ram Force . . . . . 22 Ton
- Cycle Time . . . . . 14 seconds
- Hydraulic Tank Capacity . . . . . 5 gal. (18.9 L)
- Max Log Length . . . . . 23.8 in. (60.3 cm)
- Max Log Weight . . . . . 100 lb. (45 kg)
- Coupler Ball Size . . . . . 2 in. (5 cm)
- Tire Size . . . . . 16 in. (40.6 cm)
- Max towing speed . . . . . 45 MPH (72 KPH)
- Engine . . . . . 208 cc, OHV, 4 stroke
- Cylinder size . . . . . 4 in. x 22.6 in. (10 cm x 57.5 cm)
- Cylinder rod size . . . . . 1.6 in. (4 cm)
- Gear Pump . . . . . 2-stage
- Max pressure . . . . . 3500 psi
- Max flow capacity . . . . . 11 GPM
- Control Valve . . . . . Detent (auto-return)
- **Overall Dimensions**
- Gross Weight . . . . . 429.9 lb. (195 kg)
- Net Weight . . . . . 396.8 lb. (180 kg)
- Height . . . . . 45.9 in. (116.5 cm)
- Width . . . . . 40.7 in. (103.5 cm)
- Length . . . . . 85.8 in. (218 cm)

**Engine Specifications**

- Model . . . . . 170F
- Displacement . . . . . 208 cc
- Type . . . . . 4-Stroke OHV
- Start Type . . . . . Recoil

**Spark Plugs**

**OEM spark plug:** NHSP F6RTC

**Replacement spark plug:** NGK BPR6ES or equivalent

Make certain the spark plug gap is 0.6 - 0.8 mm or (0.024 - 0.031 in.).

**Maintenance Valve Clearance**

- Intake: 0.10 – 0.15 mm (0.004 – 0.006 in.)
- Exhaust: 0.15 – 0.20 mm (0.006 – 0.008 in.)

Note: Tech bulletin regarding the valve adjustment procedure is on [www.championpowerequipment.com](http://www.championpowerequipment.com).

**Hydraulic Oil System**

Oil capacity is 6.5 gallons (24.6 L).

For year round use in warmer climates (always ABOVE 32 °F/0 °C):

- SAE 10W
- ISO 32
- SAE 32
- ISO 46
- ASLE H-150
- Universal Hydraulic/Transmission Fluid

For year round use in colder climates

(sometimes BELOW 32 °F/0 °C):

- Automatic Transmission Fluid
- Spin-On Filter – 15 GPM, 10 Micron, ¾-16 Thread.

**NOTE**

When temperature is below 32° F (0°C) use universal tractor/transmission fluid.

**Fuel**

Fuel capacity is 0.5 gallons (2 L). Use regular unleaded gasoline with a minimum octane rating of 85 and an ethanol content of less than 10% by volume.

**Oil**

Use 10W-30 automotive oil.

Oil capacity is 0.6 qt. (0.6 L).

DO NOT OVERFILL.

Please reference the following chart for recommended oil types for use in the log splitter.

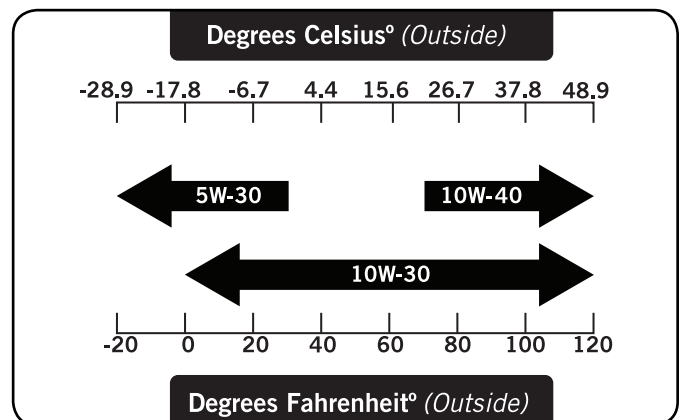

# SPECIFICATIONS

## Parts Diagram

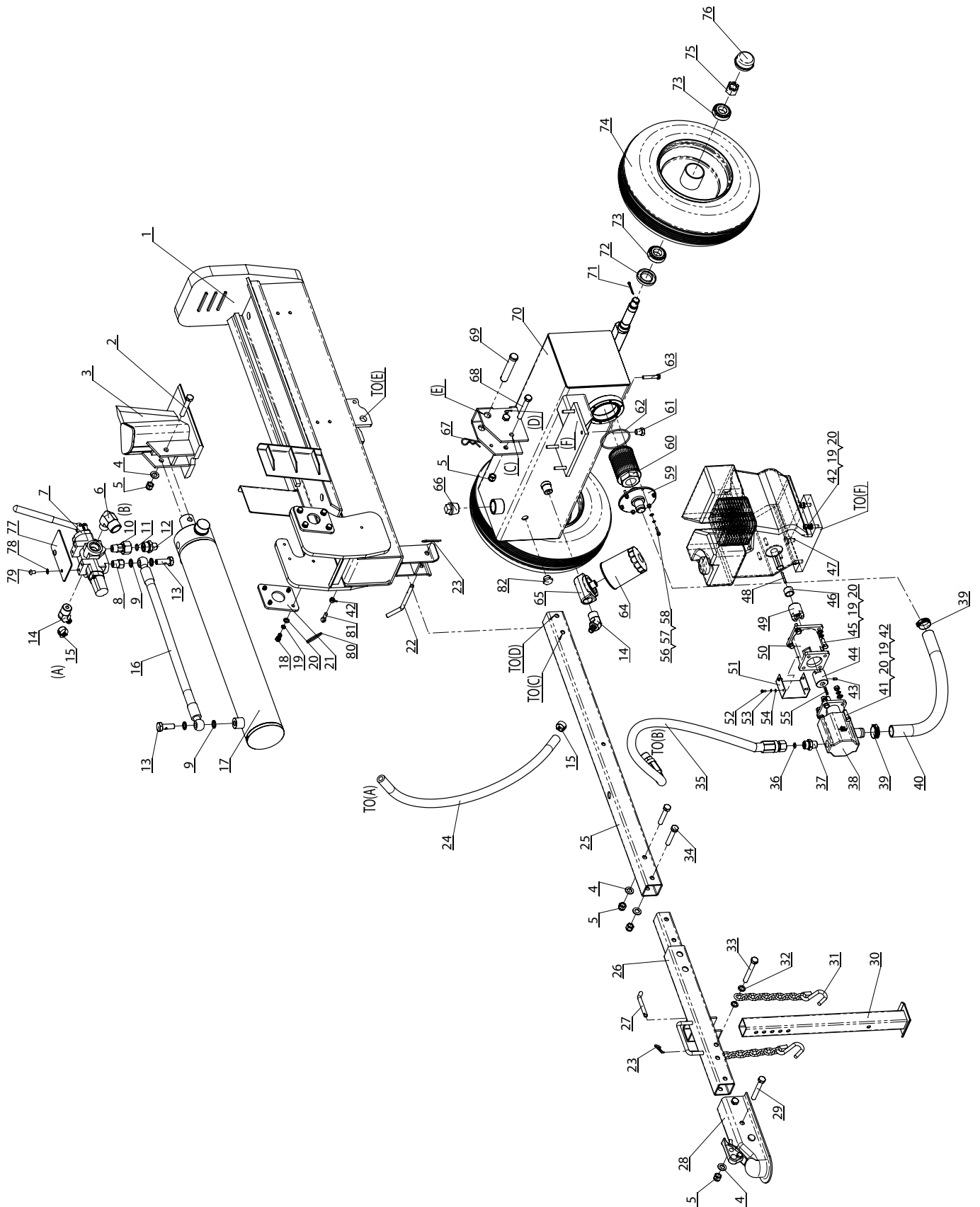



#	Part number	Description	Qty
1	PMJ22J-02-00	Beam	1
2	GB/T 5782-2000	BOLT M12×75(12.9)	1
3	PMJ22J-04-00	Wedge Slide	1
4	GB/T 95-2000	Washer 12	7
5	GB/T 889.1-2000	Lock Nut M12	8
6	PMJ22G-51	Filter Housing "IN" Connection	1
7	PMJ22J-12	Control Valve	1
8	PMJ22G-24	Valve Joiner	1
9	JB 982-1977	Combination Washer 14	4
10	PMJ22G-25	Valve Joiner	1
11	GB3452.1-92	"O" Ring 14×2.65	1
12	PMJ22G-22	Front Cover Connector	1
13	PMJ22G-23	Bolt Connector	2
14	PMJ22G-49	Filter Housing "OUT" Connection	2
15	JB/T 8870-1999	Clamp d25	2
16	PMJ22G-16	Hydraulic Hose(Valve-Cylinder)	1
17	PMJ22J-08-00	Cylinder	1
18	GB/T 5783-2000	Bolt M8×20	8
19	GB/T 93-1987	Lock Washer 8	20
20	GB/T 95-2000	Washer 8	20
21	PMJ22J-03	Cylinder Fixing Plate	2
22	PMJ22J-15	Pin	1
23	PMJ22G-30	R Pin	2
24	PMJ22G-15	Hydraulic Hose(Valve-Oil Tank)	1
25	PMJ22J-06	Base Tube	1
26	PMJ22J-01-00	Base Connector	1
27	PMJ22J-10	Pin	1
28	PMJ22G-40	2 in. (5.1 cm) Coupler	1
29	GB/T 5782-2000	Bolt M12×80	2
30	PMJ22J-07-00	Front Support Leg	1
31	PMJ22G-41	Safety Chain With Hook	2
32	GB/T 97.2-1985	Washer 12	4
33	GB/T 5782-2000	Bolt M12×90	1
34	GB/T 5782-2000	Bolt M12×65	2
35	PMJ22J-18	Hydraulic Hose(Valve-Pump)	1
36	GB/T 3452.1-92	"O" Ring 10×2.65	1
37	PMJ22G-21	Outlet Connector Of Pump	1
38	PMJ22J-14	Gear Pump	1
39	JB/T 8870-1999	Clamp d40	2
40	PMJ22G-17	Oil Pipe	1
41	GB/T 5783-2000	Bolt M8×30	4

#	Part number	Description	Qty
42	GB/T 6170-2000	Nut M8	9
43	GB/T 77-2000	Screw M6×10	1
44	PMJ22G-26	Gear Pump Connector	1
45	ASME B18.2.1 1996	Bolt 5/16"-24×1"	4
46	PMJ22G-29	Engine Bushing	1
47	TC7Q002	Engine	1
48	GB/T 1096-1979	Flat Key 5x5	1
49	PMJ22G-28	Engine Connector	1
50	PMJ22G-27	Gear Pump Stand	1
51	PMJ22G-32	Connector Cover	1
52	GB/T 845C-1985	Tapping Screw	4
53	GB/T 848-1985	Lock Washer 4	4
54	GB/T 859-1987	Washer 4	4
55	GB/T 1099-1979	Flat Key 3x3	1
56	GB/T 70.1-2000	Screw M5×20	6
57	GB/T 93-1987	Lock Washer 5	6
58	GB/T 95-1985	Washer 5	6
59	PMJ22G-07-00	Filter Fix Plate	1
60	PMJ22G-44	Filter	1
61	PMJ22G-19	Oil Plug	1
62	GB/T 3452.1-92	"O" Ring 80×3.55	1
63	GB/T 5782-2000	Bolt M8×45	4
64	PMJ22G-52	Auto Filter	1
65	PMJ22G-50	Auto Filter Base	1
66	PMJ22G-18	Screw NPT 1 in. (2.5 cm)	1
67	GJY12-3	R Pin	1
68	GB/T 5782-2000	Bolt M12×85	2
69	PMJ22G-12	Hinge Pin	1
70	PMJ22J-11-00	Oil Tank	1
71	GB/T 91-2000	Cotter Pin 4×32	2
72	PMJ22J-05-01	Cased Seal	2
73	L44634 LYC DS	Tapered Bearing	4
74	PMJ22J-05-03	Wheel	2
75	GB/T 9459-1988	Slotted Nut M20×1.5	2
76	PMJ22J-05-02	Axle Cap	2
77	PMJ22J-19	Plate	1
78	GB/T 859-1987	Washer 8	2
79	GB/T 818-2000	Bolt M8x12	2
80	PMJ22G-38	Big Tension Spring	1
81	GB/T 798-1988	Swing Bolt M8x28	1
82	GB 1160.2-89	Oil Scale	1

# SPECIFICATIONS

## Engine Parts Diagram

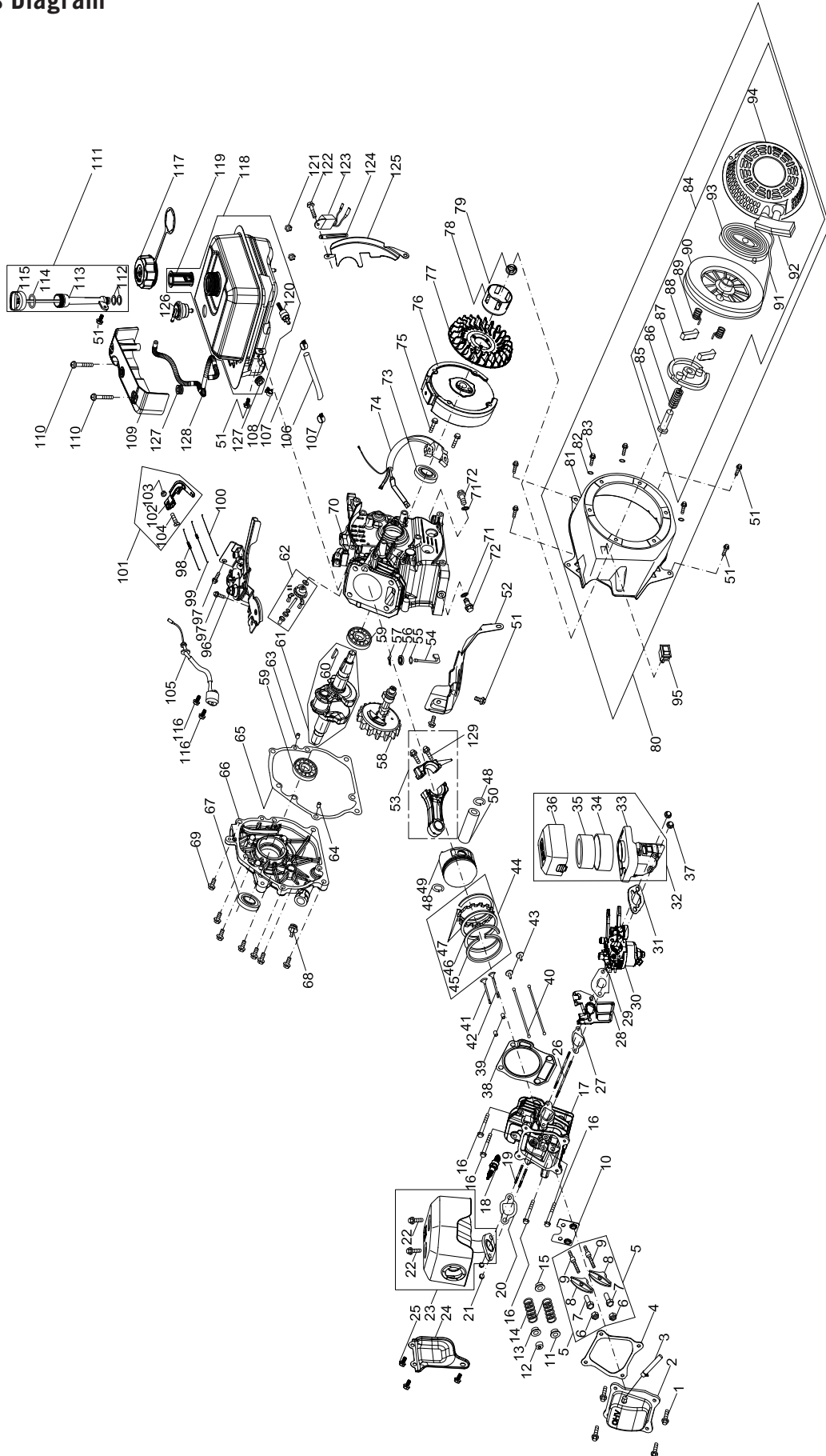

#	Part Number	Description	Qty
1	B057890006001670X	Bolt M6x16	4
2	11221-LC90-0500	Valve Cover	1
3	12104-KB01-0200	Breather Hose Assembly	1
4	90229-KB01-0400	Valve Cover Gasket	1
5	15400-LC90-0001	Rocker Arm Assembly	2
6	15414-KB01-0000	Nut,Pivot Locking	2
7	15403-KB01-0000	Adjusting Nut,Valve	2
8	15401-LC90-0001	Rocker Arm	2
9	15415-KB01-0000	Bolt,Pivot	2
10	15406-KB01-0000	Push Rod Guide	1
11	15711-KB01-0000	Valve Spring Retainer (Intake)	1
12	15713-KB01-0000	Exhaust Lash Cap	1
13	15712-KB01-0000	Valve Spring Retainer (Exhaust)	1
14	15703-KB01-0000	Valve Spring	2
15	1572B-JD45-0000	Valve Seal (Intake)	1
16	1122R-LC90-0000	Bolt M8x60	4
17	1122B-LC90-0300	Cylinder Head	1
18	81300-KB01-0400	Spark Plug(F6RTC)	1
19	91138-KB03-0000	Stud M8x34	2
20	18066-LC90-0000	Exhaust Pipe Gasket	1
21	B061700008000060X	Nut,M8	2
22	B0578900060010702	Bolt M6x10	2
23	18000-LZ4A-0000	Muffler Assembly	1
24	18016-LZ4A-0000	Exhaust Pipe Guard	1
25	B057890006000870H	Bolt M6x8	3
26	91127-KB01-0000	Stud M6x113	2
27	17107-LC90-0100	Carburetor Insulator Gasket	1
28	17112-KB01-0000	Carburetor Insulator	1
29	17182-KB01-0300	Carburetor Gasket	1
30	17100-LC90-2900	Carburetor Assembly	1
31	17113-KB01-0000	Carburetor Gasket Plate	1
32	16100-LZ4A-0100	Air Cleaner Assembly	1
33	16180-LZ4A-0100	Air Cleaner Housing	1
34	16104-IC77-0000	Sponge Filter	1
35	16101-IC77-0000	Air Cleaner Filter Assembly	1
36	16105-LZ4A-0000	Air Cleaner Cover	1
37	B06177P106000090X	Nut M6	2
38	9022B-LC90-0200	Gasket,Cylinder Head	1
39	91521-10001600000	Dowel Pin Ø10x16	2
40	15321-LC90-0000	Push Rod	2
41	15702-LC90-0000	Exhaust Valve	1
42	15701-KC67-0000	Intake Valve	1
43	15002-LC90-0000	Tappet	2
44	1310A-LZ4A-0000	Piston Ring Set	1
45	13103-LZ4A-0000	1St Piston Ring	1
46	13104-LZ4A-0000	2Nd Piston Ring	1
47	13120-LZ4A-0000	Oil Ring	1
48	13105-KB01-0000	Piston Pin Snap Ring	2
49	13101-LC90-0100	Piston	1
50	13102-LC90-0000	Piston Pin	1
51	B057890006001270X	Bolt M6x12	8
52	19113-Z6H-0000	Air Shield	1
53	13220-LC90-0000	Connecting Rod Assembly	1
54	24605-LC90-0000	Governor Arm Shaft	1
55	90101-10052000190	Washer Ø5.2x1.9	1
56	T1105006001100400	Governor Seal	1
57	24606-KB01-0000	Cotter Pin	1
58	15100-LC90-0000	Camshaft Assembly	1
59	92102-00000006205	Radial Ball Bearing,6205	2
60	91601-IB84-0000	Woodruff Key	1
61	13230-LC90-1400	Crankshaft Assembly	1
62	24620-LC90-0200	Governor Gear/Shaft Assembly	1
63	91521-07001400000	Dowel Pin Ø7x14	1
64	91521-09001400000	Dowel Pin Ø9x14	1
65	90208-LC90-0100	Crankcase Cover Gasket	1
66	12301-LC90-0002	Crankcase Cover	1
67	T1107025004125600	Oil Seal,Ø25xØ41.25x6	1

#	Part Number	Description	Qty
68	14311-LC90-0000CD	Dipstick Assembly	1
69	B057890008003270X	Bolt M8x32	7
70	12007-LG10-0700	Crankcase	1
71	91302-91001516000	Washer	2
72	91103-KB01-0000	Oil Drain Plug	2
73	T1105025004125600	Oil Seal Ø25xØ41.25x6	1
74	81200-LD29-0200	Ignition Coil Assembly	1
75	B057890006002570X	Bolt M6x25	2
76	82150-LC90-1400	Flywheel	1
77	19102-KB01-0100	Cooling Fan	1
78	21520-KB01-0700	Starter Cup	1
79	B06177F014000090X	Nut,Special,M14x1.5	1
80	21500-LZ4A-0600CD	Recoil Starter	1
81	21530-Z6H-0200CD	Blower Housing	1
82	B000950006000000X	Gasket Ø6	3
83	B16674A006001070X	Bolt M6x10	3
84	21510-LC90-14006X	Recoil Starter	1
85	21521-KB01-0000	Alignment Bolt	1
86	21518-KB01-0000	Spring	1
87	21513-KB01-0000	Guide Plate	1
88	21512-KB01-0000	Starter Pawl	2
89	21515-KB01-0000	Return Spring, Starter Pawl	2
90	21511-KB01-0000	Starter Reel	1
91	21517-KB01-0100	Starter Rope	1
92	21516-IB84-0000	Starter Handle	1
93	21514-LC90-0100	Recoil Spring	1
94	21519-LC90-07006X	Blower Housing	1
95	72380-IB84-0200	Ignition Switch	1
96	24610-KB01-2300	Primer Bracket	1
97	B057870006001270X	Bolt M6x12	2
98	24602-LC90-1100	Governor Spring	1
99	24603-KB01-0300	Throttle Linkage Spring	1
100	24604-KB01-0000	Throttle Linkage	1
101	24640-LC90-0000	Governor Arm Assembly	1
102	24607-LC90-0000	Governor Arm	1
103	B06177P106000090X	Nut M6	1
104	91121-1060-02120X	Governor Arm Bolt	1
105	87400-LC90-0200	Oil Sensor	1
106	T2999404001000108	Fuel Hose	1
107	17020-KB01-0400	Fuel Hose Clamp Ø9.5x8	2
108	10061-LZ4A-0000	Wire Clamp	1
109	14304-LZ4A-0100	Dipstick Decoration Cover	1
110	24681-LC90-0000	Bolt	2
111	14301-LC90-0500MV	Dipstick Assembly	1
112	90101-10155000150	Oil Filler Tube O-Ring	2
113	14312-LC90-0100MV	Oil Filler Tube	1
114	90101-30210000277	Oil Filler Tube O-Ring	1
115	14312-LC90-0100MV	Oil Filler Plug	1
116	B057870006001670X	Flange Bolt M6x16	2
117	61120-JC79-0700	Cap Componet,Fuel Tank	1
118	61100-LZ4A-04006X	Fuel Tank Assembly	1
119	61137-LC90-0300	Fuel Filter	1
120	61195-IB71-1300	Fuel Tank Nipple	1
121	B061770106000090X	Nut,M6	2
122	B057890006002070X	Bolt M6x20	1
123	87420-KB01-0000	Isolators	1
124	10008-9999-0100	Line Clamp	1
125	19112-LC90-0100	Blower Housing Shield	1
126	6114M-LC90-0000	Check Valve	1
127	61182-QD03-0000	Rubber Pad	2
128	61101-LZ4A-0100	Fuel Hose	1
129	13215-KB01-0000	Connecting Rod Bolt	2

# WARRANTY

## WARRANTY

CHAMPION POWER EQUIPMENT  
1-YEAR LIMITED WARRANTY

### Warranty Qualifications

Champion Power Equipment (CPE) will register this warranty upon receipt of your Warranty Registration Card and a copy of your sales receipt from one of CPE's retail locations as proof of purchase.

Please submit your warranty registration and your proof of purchase within ten (10) days of the date of purchase.

### Repair/Replacement Warranty

CPE warrants to the original purchaser that the mechanical and electrical components will be free of defects in material and workmanship for a period of one (1) year from the original date of purchase (90 days for commercial and industrial use). Transportation charges on product submitted for repair or replacement under this warranty are the sole responsibility of the purchaser. This warranty only applies to the original purchaser and is not transferable.

### Do Not Return The Unit To The Place Of Purchase

Contact CPE's Technical Service and CPE will troubleshoot any issue via phone or e-mail. If the problem is not corrected by this method, CPE will, at its option, authorize evaluation, repair or replacement of the defective part or component at a CPE Service Centre. CPE will provide you with a case number for warranty service. Please keep it for future reference. Repairs or replacements without prior authorization, or at an unauthorized repair facility, will not be covered by this warranty.

### Warranty Exclusions

This warranty does not cover the following repairs and equipment:

#### Normal Wear

Log Splitter needs periodic parts and service to perform well. This warranty does not cover repair when normal use has exhausted the life of a part or the equipment as a whole.

#### Installation, Use and Maintenance

This warranty will not apply to parts and/or labour if this log splitter is deemed to have been misused, neglected, involved in an accident, abused, loaded beyond its limits, modified, and installed improperly. Normal maintenance such as spark plugs, air filters, adjustments, fuel system cleaning and obstruction due to buildup is not covered by this warranty.

### Other Exclusions

This warranty excludes:

- Cosmetic defects such as paint, decals, etc.
- Wear items such as filter elements, o-rings, etc.
- Accessory parts such as starting batteries, and storage covers.
- Failures to due acts of God and other force majeure events beyond the manufacturer's control.
- Problems caused by parts that are not original Champion Power Equipment parts.

### Limits of Implied Warranty and Consequential Damage

Champion Power Equipment disclaims any obligation to cover any loss of time, use of this product, freight, or any incidental or consequential claim by anyone from using this log splitter. **THIS WARRANTY IS IN LIEU OF ALL OTHER WARRANTIES, EXPRESS OR IMPLIED, INCLUDING WARRANTIES OF MERCHANTABILITY OR FITNESS FOR A PARTICULAR PURPOSE.**

A unit provided as an exchange will be subject to the warranty of the original unit. The length of the warranty governing the exchanged unit will remain calculated by reference to the purchase date of the original unit.

This warranty gives you certain legal rights which may change from state to state or province to province. Your state or province may also have other rights you may be entitled to that are not listed within this warranty.

### Contact Information

#### Address

Champion Power Equipment, Inc.  
Customer Service  
10006 Santa Fe Springs Rd.  
Santa Fe Springs, CA 90670  
[www.championpowerequipment.com](http://www.championpowerequipment.com)

#### Customer Service

Mon – Fri 8:30 AM – 5:00 PM (PST/PDT)  
Toll Free: 1-877-338-0999  
[info@championpowerequipment.com](mailto:info@championpowerequipment.com)  
Fax no.: 1-562-236-9429

#### Technical Service

Mon – Fri 8:30 AM – 5:00 PM (PST/PDT)  
Toll Free: 1-877-338-0999  
[tech@championpowerequipment.com](mailto:tech@championpowerequipment.com)  
24/7 Tech Support: 1-562-204-1188

**Champion Power Equipment, Inc (CPE),  
Emission Control System Warranty**

Your Champion Power Equipment (CPE) engine complies with Environment Canada (EC) emission regulations.

**YOUR WARRANTY RIGHTS AND OBLIGATIONS:**

CPE is pleased to explain the Emission Control Systems Warranty on your 2014 small off-road engine. New engines must be designed, built and equipped, at the time of sale, to meet EC regulations for small non-road engines. CPE must warrant the emission control system on your small off-road engine for the period of time listed below, provided there has been no abuse, neglect, unapproved modification, or improper maintenance of your small off-road engine.

Your emission control system may include parts such as the carburetor, fuel-injection system, the ignition system, catalytic converter and fuel lines. Also included may be hoses, belts, connectors and other emission related assemblies. Where a warrantable condition exists, CPE will repair your small off-road engine at no cost to you including diagnosis, parts and labor.

**MANUFACTURER'S EMISSION CONTROL SYSTEM WARRANTY COVERAGE:**

This emission control system is warranted for two years, subject to provisions set forth below. If, during the warranty period, emission related part on your engine is defective in materials or workmanship, the part will be repaired or replaced by CPE.

**OWNER WARRANTY RESPONSIBILITIES:**

As the small off-road engine owner, you are responsible for the performance of the required maintenance listed in your Owner's Manual. CPE recommends that you retain all your receipts covering maintenance on your small off-road engine, but CPE cannot deny warranty solely for the lack of receipts or for your failure to ensure the performance of all scheduled maintenance.

**As the small off-road engine owner, you should however be aware that CPE may deny you warranty coverage if your small, off-road engine or a part has failed due to abuse, neglect, improper maintenance or unapproved modifications.**

You are responsible for presenting your small off-road engine to an Authorized CPE service outlet, CPE dealer or CPE, Santa Fe Springs, CA., USA as soon as a problem exists. The warranty repairs should be completed in a reasonable amount of time, not to exceed 30 days.

If you have any questions regarding your warranty rights and responsibilities, you should contact:

Champion Power Equipment, Inc.  
Customer Service  
10006 Santa Fe Springs Road  
Santa Fe Springs, CA 90670  
USA  
Tel: 1-877-338-0999  
tech@championpowerequipment.com

## **EMISSION CONTROL SYSTEM WARRANTY**

**The following are specific provisions relative to your Emission Control System Warranty Coverage.**

Emission Control System Warranty (ECS Warranty):

**1. APPLICABILITY:** The ECS Warranty Period shall begin on the date the new engine or equipment is delivered to its original, end-use purchaser, and shall continue for 24 consecutive months thereafter.

### **2. GENERAL EMISSIONS WARRANTY COVERAGE**

CPE warrants to the original, end-use purchaser of the new engine or equipment and to each subsequent purchaser that each of its small off-road engines is:

a. Designed, built and equipped so as to conform at the time of sale with applicable regulations under the Canadian Environmental Protection Act, 1999 (CEPA 1999).

b. Free from defects in materials and workmanship that cause the failure of a warranted part to be identical in all material respects to the part as described in the engine manufacturer's application for certification for a period of two years.

### **3. THE WARRANTY ON EMISSION-RELATED PARTS WILL BE INTERPRETED AS FOLLOWS:**

a. Any warranted part that is not scheduled for replacement as required maintenance in the Owners Manual shall be warranted for the ECS Warranty Period. If any such part fails during the ECS Warranty Period, it shall be repaired or replaced by CPE according to Subsection "d" below. Any such part repaired or replaced under the ECS Warranty shall be warranted for any remainder of the ECS Warranty Period.

b. Any warranted, emissions-related part which is scheduled only for regular inspection as specified in the Owners Manual shall be warranted for the ECS Warranty Period. A statement in such written instructions to the effect of "repair or replace as necessary", shall not reduce the ECS Warranty Period. Any such part repaired or replaced under the ECS Warranty shall be warranted for the remainder of the ECS Warranty Period.

c. Any warranted, emissions-related part which is scheduled for replacement as required maintenance in the Owner's Manual shall be warranted for the period of time prior to the first scheduled replacement point for that part. If the part fails prior to the first scheduled replacement, the part shall be repaired or replaced by CPE according to Subsection "d" below. Any such emissions-related part repaired or replaced under the ECS Warranty, shall be warranted for the remainder of the ECS Warranty Period prior to the first scheduled replacement point for such emissions-related part.

d. Repair or replacement of any warranted, emissions-related part under this ECS Warranty shall be performed at no charge to the owner at a CPE Authorized Service Outlet.

e. The owner shall not be charged for diagnostic labor which leads to the determination that a part covered by the ECS Warranty is in fact defective, provided that such diagnostic work is performed at a CPE Authorized Service Outlet.

f. CPE shall be liable for damages to other original engine components or approved modifications proximately caused by a failure under warranty of an emission-related part covered by the ECS Warranty.

g. Throughout the ECS Warranty Period, CPE shall maintain a supply of warranted emission-related parts sufficient to meet the expected demand for such emission-related parts.

h. Any CPE Authorized and approved emission-related replacement part may be used in the performance of any ECS Warranty maintenance or repair and will be provided without charge to the owner. Such use shall not reduce CPE's warranty obligation.

i. Unapproved add-on or modified parts may not be used to modify or repair a CPE engine. Such use voids this ECS Warranty and shall be sufficient grounds for disallowing an ECS Warranty claim. CPE shall not be liable hereunder for failures of any warranted parts of a CPE engine caused by the use of such an unapproved add-on or modified part.

**EMISSION-RELATED PARTS INCLUDE THE FOLLOWING: (using those portions of the list applicable to the engine)**

Systems covered by this warranty	Parts Description
Fuel Metering System	Fuel regulator, Carburetor and internal parts
Air Induction System	Air cleaner, Intake manifold
Ignition System	Spark plug and parts, Magneto ignition system
Exhaust System	Exhaust manifold, catalytic converter
Miscellaneous Parts	Tubing, Fittings, Seals, Gaskets, and Clamps associated with these listed systems.

**TO OBTAIN WARRANTY SERVICE:**

You must take your CPE engine or the product on which it is installed, along with your warranty registration card or other proof of original purchase date, at your expense, to any Champion Power Equipment dealer who is authorized by Champion Power Equipment, Inc. to sell and service that CPE product during his normal business hours. Claims for repair or adjustment found to be caused solely by defects in material or workmanship will not be denied because the engine was not properly maintained and used.

**If you have any questions regarding your warranty rights and responsibilities, or to obtain warranty service, please write or call Customer Service at Champion Power Equipment, Inc.**

**Champion Power Equipment, Inc.  
10006 Santa Fe Springs Road  
Santa Fe Springs, CA 90670  
USA  
1-877-338-0999  
Attn: Customer Service  
tech@championpowerequipment.com**