

476736

**NOTICE TO PERSONS RECEIVING THIS
DRAWING
AND/OR TECHNICAL INFORMATION:**

Checkpoint Systems claims proprietary rights to the material disclosed hereon.

This drawing and/or technical information is issued in confidence for engineering information only and may not be reproduced or used to manufacture anything shown or referred to hereon without direct written permission from Checkpoint Systems to the user. This drawing and/or technical information is the property of Checkpoint Systems and is loaned for mutual assistance, to be returned when its purpose has been served.

**THIS DRAWING AND/OR TECHNICAL INFORMATION IS THE
PROPERTY OF CHECKPOINT SYSTEMS, INC.**

Title:

**INSTALLATION & TUNE-UP
PROCEDURE
COUNTERPOINT IX**

Revisions

Revisions

Rev	Description	Date	Engineer	Rev	Description	Date	Approved
-----	-------------	------	----------	-----	-------------	------	----------

00

		Doc. Spec:	Date:
		Dwn:	Date:
		Chk:	Date:
		Eng	Date:
Used On		Appd:	Date:



Size A

476736

Scale: N/A

©Checkpoint Systems, Inc. 1996

Page 1 of 28



Table Of Contents

<u>Section</u>	<u>Description</u>	<u>Page</u>
A	Forward.	4
1.0	System Description	5-7
1.1	System Overview	5
1.1.1	How the System Works	5
1.1.2	System Effectiveness	5
1.2	Chassis	6
1.3	Power Supply and C/PT resettable fuse	6
1.4	Remote Unit	6
1.5	Antenna	6
1.6	Target	6
2.0	Recommended Tools and Equipment	7
2.1	Electronic Test Equipment	7
	<i>Table 2.1 - Recommended Electronic Test Equipment</i>	7
2.2	Installation Tools	7
	<i>Table 2.2 - Recommended Installation Tools</i>	7
3.0	Wiring the C/PT IX	8-11
3.1	Power Connection	8
	<i>Figure 3.1 - wire Connection</i>	8
3.2	Antenna Connection	9
3.2.1	Pad Connection	9
	<i>Figure 3.2.1 - Pad Connection</i>	9
3.2.2	Scanner Antenna Connection	10
	<i>Figure 3.2.2 - Scanner Connection</i>	10
3.3	Slaving Connection	10
3.3.1	Wire Slaving	10
3.3.2	Fiber Slaving	11
3.3.3	Secure Cables	11
3.4	Interlock Connection	11
3.5	Remote Unit Connection	11
	<i>Table 3.5 - Remote Unit Connection</i>	11
4.0	Install the C/PT IX	12-14
4.1	Chassis Installation	12
	<i>Figure 4.1A - Horizontal Chassis Installation</i>	12
	<i>Figure 4.1B - Vertical Chassis installation</i>	13
4.2	Remote Unit Installation	13
	<i>Figure 4.2A - Vertical Remote Unit Installation</i>	13
	<i>Figure 4.2B - Horizontal Remote Unit Installation</i>	14

 INSTALLATION & TUNE-UP PROCEDURE
 COUNTERPOINT IX

 March 9, 2000
 FCC ID: D04CP1900

5.0	C/PT IX DIP Switch Configuration	14-18
5.1	Antenna Matching	15
	<i>Table 5.1 - Antenna Matching Chart</i>	15
5.2	IV Mode	16
	<i>Table 5.2 - Settings for IV Mode</i>	16
5.3	V Mode	17
	<i>Table 5.3 - Settings for V Mode</i>	17
5.4	VI Mode	18
	<i>Table 5.4 - Settings for VI Mode</i>	18
6.0	C/PT IX Tune-Up and Test Procedure	19-20
6.1	Center Frequency and Deviation Verification	19
6.2	IV Mode	19
6.3	V Mode	19
6.4	VI Mode	20
6.5	Interlock Turn-On Time Adjustment	20
7.0	After the Installation	20-21
7.1	Turning the Deactivator On and Off	20
7.2	How the Deactivator Works	20
7.3	When the Tag Doesn't Deactivate	20-21
7.4	When the Sensing System Alarms	21
7.5	Testing the Deactivator	21
7.6	Operational Problems	21
7.7	Tagging	21
8.0	Figures and Tables	22-26
8.1	Test Points and Adjustments	22
	<i>Figure 8.1 - Test Points and Adjustments</i>	22
8.2	Slave/Inhibit Decision Chart	23
	<i>Table - 8.2 C/PT IX Slaving/Inhibit Decision Chart</i>	23
8.3	DIP Switch Settings	24
	<i>Table 8.3 - DIP Switch Settings</i>	24
8.4	INTERLOCK Time Adjustment Chart	25
	<i>Table 8.4 - INTERLOCK Time Adjustment Chart</i>	25
8.5	Performance Matrix	26
	<i>Table 8.5 - Performance Matrix</i>	26
Appendix A	Fine Tuning	27-29
A.1	Detailed Tuning in IV Mode	27-29
	<i>Figure A1.1 - AC Signal at TP2 with SW1,2 (1) On</i>	27
	<i>Figure A1.2 - AC Signal at TP2 with SW1,2 (5,6) On</i>	27
	<i>Figure A1.3 - AC Signal at TP2 with SW1,2 (3,4,5,6) On</i>	28
	<i>Figure A1.4 - AC Signal at TP4</i>	29
A.2	Detailed Tuning in V Mode	29
A.3	Detailed Tuning in VI Mode	29

**Scope of Document**

This manual describes the steps necessary to install, tune, test and operate the C/PT IX Deactivation system.

Manual Structure

This manual is organized with the following structure:

- | | |
|-------------|---|
| Section 1.0 | Describes the C/PT IX system components and how they work. |
| Section 2.0 | Lists the tools recommended to install, tune and test the C/PT IX system. |
| Section 3.0 | Lists and describes steps required to wire the C/PT IX system. |
| Section 4.0 | Lists and describes steps required to install the C/PT IX system. |
| Section 5.0 | Lists and describes steps to tune and test the C/PT IX system. |

Required Knowledge and Skill

This manual assumes that you have the technical skill and electronic knowledge you need to:

- Read a wiring diagram
- Connect and read electronic test instruments
- Make electrical wiring connections
- Do light construction work using hand and small power tools

Editorial Conventions

This manual numbers each paragraph and table to help you find information easily and quickly. Two levels of decimals indicate subsections; for example: 5.1 or 2.3.3 Tables and figures carry the number of the subsection in which they appear rather than consecutive numbers.



1.0 System Description

1.1 System Overview

Checkpoint's C/PT IX deactivation system dramatically cuts inventory shrinkage losses from customer shoplifting and employee pilferage when used in conjunction with a Checkpoint electronic article merchandising system. Although not foolproof, C/PT IX can reduce losses in retail stores so effectively that the savings will quickly exceed the system's cost. This manual describes how to install, tune, and test the C/PT IX system.

A complete C/PT IX system consists of one chassis, one or two pads or scanner antennas and targets attached to protected inventory. The pad rests on the top of the checkout counter where tagged merchandise can pass over it. The chassis is usually mounted under or inside the checkout counter. Clerks deactivate these targets at checkout. If someone should try to exit through the sensing system with an active target, an alarm sounds. The manager can then intercept and verify the item has been properly purchased.

1.1.1 How the System Works

One chassis can drive up to two pads or up to two scanner/deactivators or a combination of both. A random pulsed-RF signal is generated by the chassis. This signal is sent through a cable or cables connected to one or two pads creating a RF field above the pad(s). When a Checkpoint target enters the field, it responds to the chassis' signal by resonating and emitting a signal of its own. Depends on its operating modes, the chassis either picks up the target's signal, and amplifies the subsequent pulses to destroy or deactivate the target, or operates in the high power mode to destroy or deactivate the target all the time.

1.1.2 System Effectiveness

It is possible to subvert the C/PT IX system. For example, targeted merchandise can be deactivated by customers, then concealed. Customers could also remove targets from protected merchandise. Customers can learn these and other tricks to evade security measures.

Most theft loss arises from impulsive shoplifters, who sense an opportunity to steal and spontaneously act to take advantage of it. C/PT IX, in conjunction with a sensing system, acts effectively to discourage these casual shoplifters, and they seldom learn how to defeat this system.

**INSTALLATION & TUNE-UP PROCEDURE
COUNTERPOINT IX**March 9, 2000
FCC ID: D04CP1900**1.2 Chassis**

The chassis is mounted inside or under the checkout stand so that it is within 8 feet of an AC power outlet, 7 feet of a pad, 5 feet of a scanner antenna.

On the unit's face are:

- a recessed power switch,
- an access hole to the internal volume control,
- a green LED (**POWER**) that lights when power is on,
- a red LED (**ALARM**) that lights when a live tag is detected,
- a green LED (**SLAVE**) that lights when the C/PT IX is locked in slaved mode,
- a yellow LED (**DISABLE**) that lights when the C/PT IX is inhibited.

On the unit's back are:

- a 6-pin female connector for antenna connection,
- three access holes for power, slaving, interlock, inhibit, and remote unit cables.

1.3 Power Supply and C/PT resettable fuse

The standard C/PT IX chassis operates on 90 - 264 VAC 50/60Hz /15 VDC supply with a current rating of over 1.0 A. The C/PT IX uses a resettable fuse. To reset this fuse, turn off power, wait 1 minute and turn on power.

1.4 Remote Unit

When the C/PT IX is configured in IV or VI mode, a remote unit is needed.

On the remote unit's face are:

- a recessed power switch,
- a green LED that lights when power is on,
- a sonalert that beeps when a live tag is detected by the C/PT IX.

1.5 Antenna

The C/PT IX chassis can be used with a variety of antenna configurations. Checkpoint or some scanner manufacturers produce these antennas.

1.6 Target

The C/PT IX system is compatible with all 8.2 MHz deactivatable tags. In addition, the C/PT IX will alarm when a non-deactivatable tag is placed in its field, but it will not deactivate the tag. Occasionally, non-deactivatable paper tags (those with lower than average breakdown voltage) will be deactivated, especially when placed near a corner of the pad where field strength is greatest. The CSE should be aware of this rare event.



2.0 Recommended Tools and Equipment

2.1 Electronic Test Equipment

Table 2.1 lists the electronic equipment recommended for tuning the C/PT IX system.

Equipment	Comments
Oscilloscope	Minimum 20 MHz bandwidth, battery powered or filtered DC power supply, Two X10 probes, HITACHI V209 or equivalent.
Solid State Dip Meter	Or some type of oscillator to tune bandwidth. Delica MC200, or equivalent.
Multimeter with frequency counter	Fluke 79 Series II Multimeter or equivalent.

Table 2.1 Recommended Electronic Test Equipment

2.2 Installation Tools

The tools listed in Table 2.2 are recommended for installing the C/PT IX system.

Arrow Staple Gun, T-25	Penlight
Diagonal cutter, regular and midget	Coaxial wire strippers
Wire stripper	Crimper for RG58/59 coax cable
Electronic hand drill and bits:	Heyco bushing pliers - Heyco # 0022 (optional)
• Steel bits, assorted sizes	Screwdriver, regular
• Wood bits, assorted sizes	Screwdriver, #2, Phillips
25' heavy duty extension cord, 3-conductor	Tape measure, 25'
Marker, black felt	Tuning tool, plastic/non-conductive
Nut driver, 1/4" and 5/16"	Outlet tester
Wire snake	Wiremold removal tool
400 series test tag	A 300 Kohm or greater resistor (Used to bleed off capacitors)

Table 2.2 Recommended Installation Tools

3.0 Wiring the C/PT IX

3.1 Power Connection

The **BLACK/WHITE** or **POSITIVE** conductor from the power supply should be connected to the **PWR+** of **J2** and the **BLACK** or **GROUND** conductor from the power supply should be connected to the **PWR-** of **J2**.

If a switch is being used to cycle the power, the switch should be connected to the **SWITCH** of **J2**. If no switch is being used, place a jumper wire between those two pins of **SWITCH**. See Figure 3.1 for the detail.

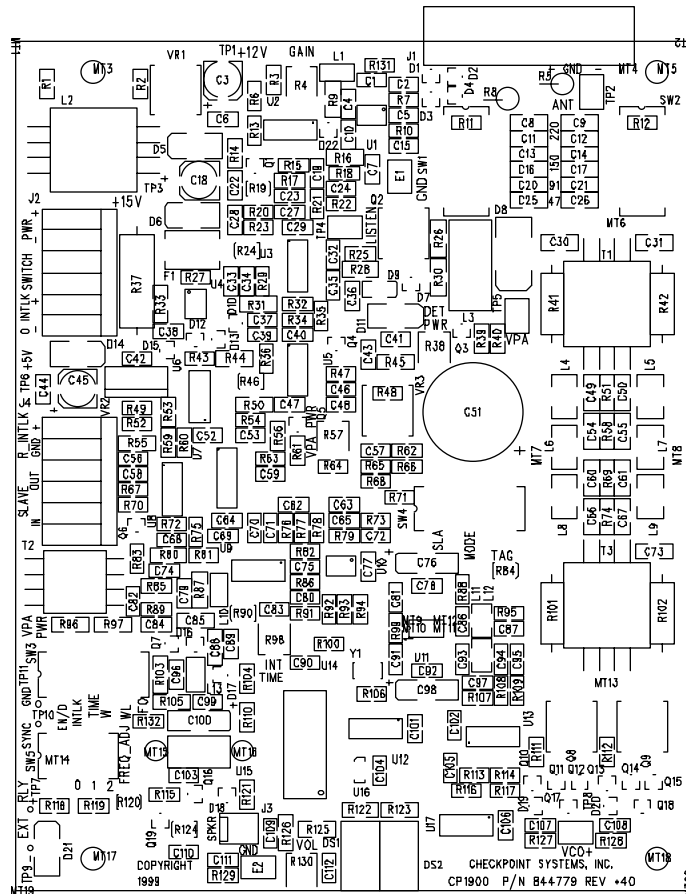

3.2 Antenna Connection

3.2.1 Pad Connection

C/PT IX can drive one or two pads or scanner/deactivators. The cable length for the pad is 8 feet. **(Don't alter the cable length under any circumstance)** Place each pad in position on its counter. The maximum distance between the two pads that are connected to a single chassis is 12 feet. The best performance can be achieved if the pad cable run straight out of the pad for at least 6" (15 cm) before it changes direction. See Figure 3.2.1. If the direct pad-chassis route takes the cable back under the pad, beneath the counter top, it's best to route the cable along the center of the pad. See Figure 3.2.1. Ensure that deactivation remains as transparent to the checkout process as possible. Connect the pads cables to either **ANT1** (pin 1,3 of J1) or **ANT2** (pin 4,6 of J1) with drain wires to **GND** (pin 2 or 5 of J1) on the C/PT IX. See Figure 3.1 for the detail.

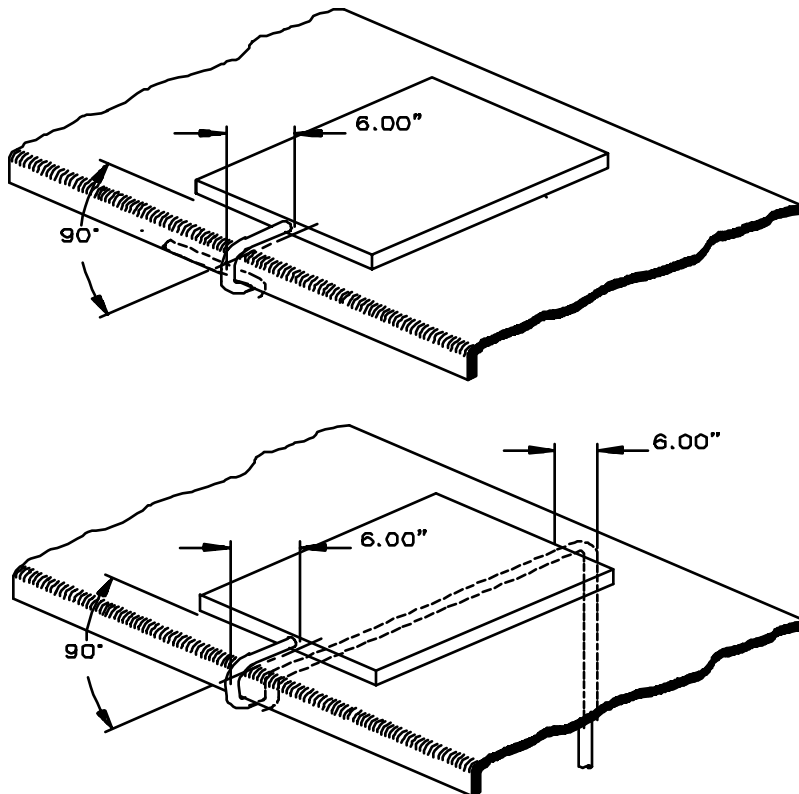

Figure 3.2.1 Pad Connection

3.2.2 Scanner Antenna Connection

To achieve optimized performance, the cable length from the chassis to 4_WAY connector or buttsplice should be kept to 6 feet in length. **(Don't alter this length under any circumstance)** Extend the scanner antenna cable by 6 feet using the 4-WAY connector or the buttsplice and the cable (Belden 8760 #18) provided with the installation kit. See Figure 3.2.2. Connect the antenna cable to either **ANT1** (pin 1,3 of J1) or **ANT2** (pin 4,6 of J1) with the drain wire to **GND** (pin 2 or 5 of J1) on C/PT IX. See Figure 3.1 for the detail.

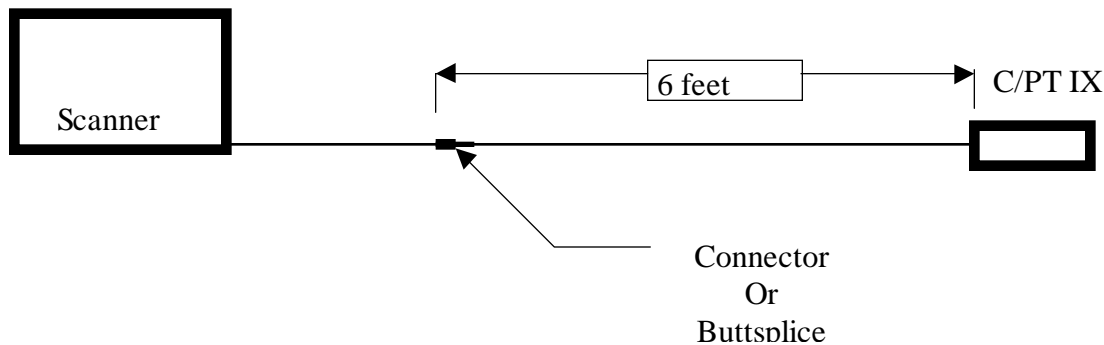

Figure 3.2.2 Scanner Connection

3.3 Slaving Connection

Whether or not the C/PT IX should be slaved to other EAS systems or deactivation systems depends on the environment of the site, the layout of the system, and the settings of the system. Refer to Table 8.1 as a guideline for the minimum distances required between the various EAS systems and the C/PT IX. If you are not sure, temporarily plug in and turn on the C/PT IX, attach the oscilloscope probe to the appropriate test point of the EAS systems receivers as you test for poor detection and phantoms.

NOTE: **The C/PT IX doesn't have MASTER SLAVE OUTPUT. It cannot be slaved to each other unless a master source such as an EAS system or fiber master exists.**

3.3.1 Wire Slaving

Connect the slaving input cable from the master source to **Slave In** (pin 5, 6 of J4). Connect the slaving output cable (daisy chain) to **Slave Out** (pin 3,4 of J4). Ground for wire slave is pin 2 of J4. See Figure 3.1 for the detail.



3.3.2 Fiber Slaving

When fiber slaving, you need the fiber receiver found in Fiber Slave Kit (P/N 469022). Plug the fiber receiver into U15 and tie wrap it. Connect the fiber cable with the connector from the fiber master to the fiber receiver.

3.3.3 Secure Cables

Secure slave/inhibit wiremold, measure, cut, and lay the cable. Secure the pad- chassis and power cables to the sales counter surfaces with cable ties. Use plastic wiremold where cables are visible to the store personnel. Secure the excess of either cable under the counter by bundling it. Do not coil it. Make sure to leave enough cable slack at the chassis end to allow service access. Leave the chassis unplugged. Install Heyco bushings at each cable entry on the rear of the deactivator chassis.

3.4 Interlock Connection

If the interlock function is used, connect the interlock input cable either directly from the scanner or from the audio interlock board to **INTLK** at J4. Notice the polarity. See Figure 3.1 for the detail.

3.5 Optional Remote Unit Connection

When configured in IV and VI modes, an optional remote unit containing a sonalert and the power **ON/OFF** switch can be connected to the C/PT IX chassis. The purpose of this unit is to provide easy access to power **ON/OFF** switch. To connect the remote unit, remove the wires from **SWITCH** at J2 of the C/PT IX chassis and cut off the exposed leads. Install the wires from the remote unit following Table 3.5. Install Heyco Bushing at the entry of the cable. See Figure 3.1 for the detail.

Cable From the Remote Unit	Connection to C/PT IX Chassis
Red, Brown and Yellow	SWITCH Pin 4 at J2 (next to SPKR)
Black and Green	SWITCH Pin 3 at J2 (next to PWR)
White	SPKR (+) at J3
Blue	SPKR (-) at J3
Orange	PWR (-) at J2

Table 3.5 Remote Unit Connection

4.0 Install the C/PT IX

4.1 Chassis Installation

The C/PT IX chassis can be installed vertically and horizontally. Ensure to install the chassis at a convenient location where the customer has easy access to **ON/OFF** switch. Unscrew and slide the cover out of the chassis, install the cover horizontally as shown in Figure 4.1A and vertically as shown in Figure 4.1B, and slide the chassis back on. Ensure to allow enough space so the chassis can slide in and out easily.

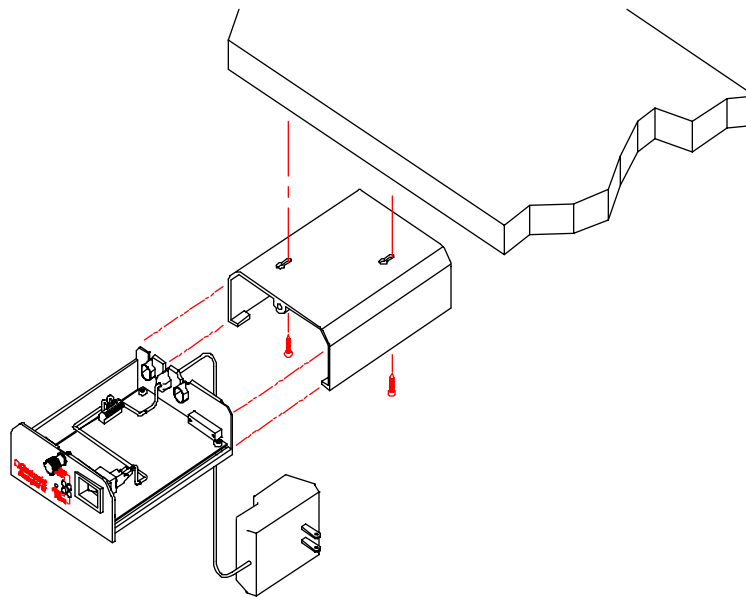

Figure 4.1A **Horizontal Chassis Installation**

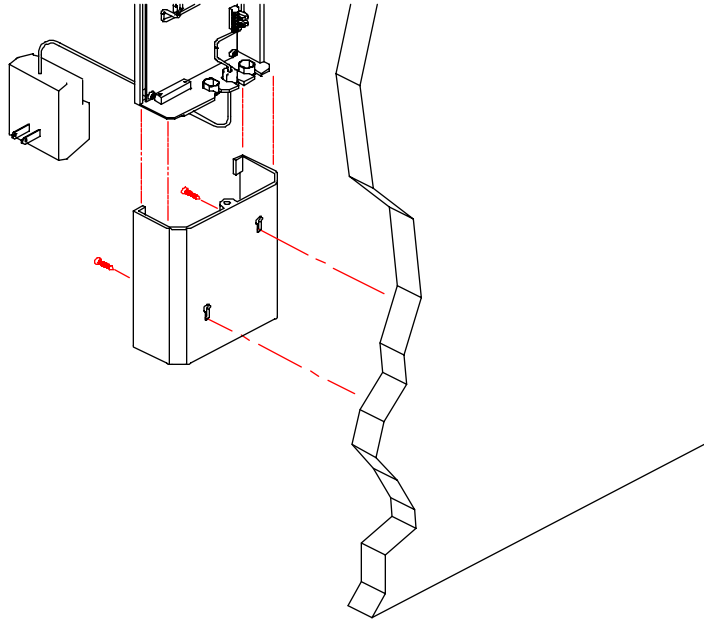

Figure 4.1B Vertical Chassis Installation

4.2 Remote Unit Installation

When a remote unit is used, it should be installed at a location where the customer has easy access to the unit. Figure 4.2A and 4.2B show examples.

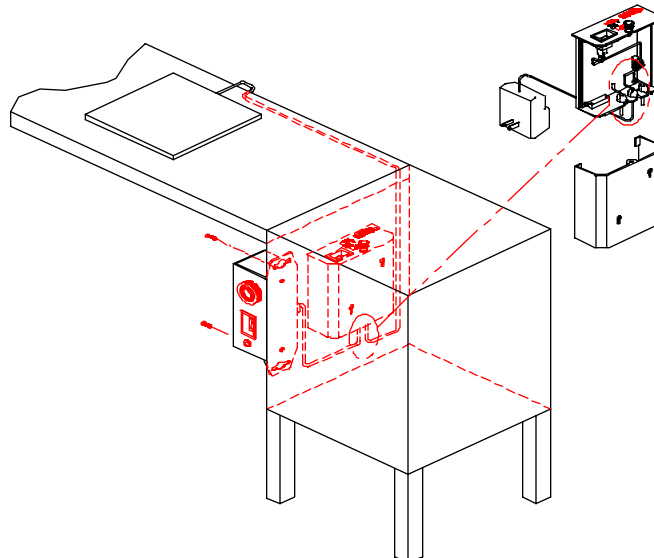

Figure 4.2A Vertical Remote Unit Installation

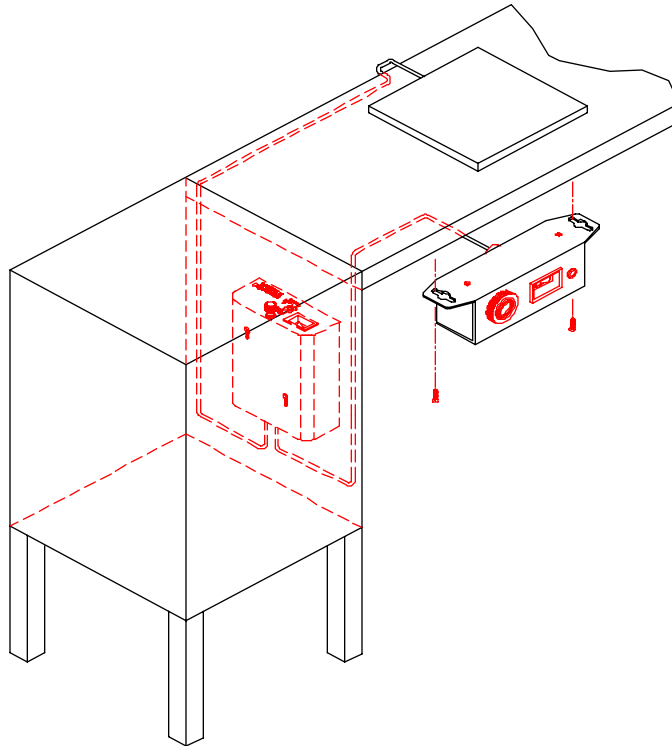

Figure 4.2B Horizontal Remote Unit Installation

5.0 C/PT IX DIP Switch Configuration

The C/PT IX can be configured as master or slave unit, operating in IV, V, or VI modes. This is done by the settings of SW1, SW2, SW3, SW4, and SW5.

In IV mode, the C/PT IX detects the tag first and switches from the low power mode to the high power mode to destroy the tag.

In V mode, the C/PT IX operates in the high power mode all the time to destroy the tag and will not detect the tag.

In VI mode, the C/PT IX operates in the high power mode all the time to destroy the tag but will detect the hard tags and any missed soft tags.

Almost all the C/PT IX's functions are configured by three banks of DIP switches. Refer to Table 8.3 for a complete listing of the DIP switches and their functions. A simplified table can also be found on the back of the chassis.

5.1 Antenna Matching



TECHNICAL DOCUMENTATION

INSTALLATION & TUNE-UP PROCEDURE
COUNTERPOINT IX

March 9, 2000
FCC ID: D04CP1900

To achieve optimized performance, the C/PT IX's output impedance needs to be matched to the scanner antenna or the pad it connects to. This is done by using DIP switches SW1 and SW2. **Table 5.1 applies to CP IV, V, or VI mode.**

Note 1: The cable length is 8 feet for the pads and 6 feet for the scanners.

Note 2: The table is for single pad or scanner. If double, refer to Section 8.0 for details.

SCANNERS	SW1,2 (1)	SW1,2 (2)	SW1,2 (3)	SW1,2 (4)	SW1,2 (5)	SW1,2 (6)
HS1250	<i>ON</i>	<i>OFF</i>	<i>OFF</i>	<i>OFF</i>	<i>ON</i>	<i>OFF</i>
LS5000	<i>OFF</i>	<i>OFF</i>	<i>ON</i>	<i>OFF</i>	<i>OFF</i>	<i>OFF</i>
LS5700	<i>ON</i>	<i>OFF</i>	<i>OFF</i>	<i>OFF</i>	<i>OFF</i>	<i>OFF</i>
LS9100	<i>OFF</i>	<i>OFF</i>	<i>ON</i>	<i>OFF</i>	<i>OFF</i>	<i>OFF</i>
MAGELLAN	<i>OFF</i>	<i>OFF</i>	<i>ON</i>	<i>OFF</i>	<i>OFF</i>	<i>OFF</i>
MAGELLAN SL	<i>ON</i>	<i>OFF</i>	<i>OFF</i>	<i>OFF</i>	<i>OFF</i>	<i>OFF</i>
NCR7820	<i>ON</i>	<i>OFF</i>	<i>OFF</i>	<i>OFF</i>	<i>ON</i>	<i>OFF</i>
NCR7824	<i>ON</i>	<i>OFF</i>	<i>OFF</i>	<i>OFF</i>	<i>ON</i>	<i>OFF</i>
NCR7870	<i>ON</i>	<i>OFF</i>	<i>OFF</i>	<i>OFF</i>	<i>OFF</i>	<i>OFF</i>
NCR7875	<i>OFF</i>	<i>OFF</i>	<i>OFF</i>	<i>OFF</i>	<i>OFF</i>	<i>ON</i>
ORION	<i>OFF</i>	<i>OFF</i>	<i>OFF</i>	<i>OFF</i>	<i>ON</i>	<i>OFF</i>
PADS	<i>ON</i>	<i>OFF</i>	<i>OFF</i>	<i>OFF</i>	<i>OFF</i>	<i>OFF</i>
SP750F	<i>ON</i>	<i>OFF</i>	<i>OFF</i>	<i>OFF</i>	<i>ON</i>	<i>OFF</i>
SP760SLS	<i>ON</i>	<i>OFF</i>	<i>ON</i>	<i>OFF</i>	<i>OFF</i>	<i>ON</i>
SP960LS	<i>ON</i>	<i>OFF</i>	<i>ON</i>	<i>OFF</i>	<i>OFF</i>	<i>OFF</i>
VS1000	<i>ON</i>	<i>OFF</i>	<i>ON</i>	<i>OFF</i>	<i>OFF</i>	<i>OFF</i>
VS1000S	<i>ON</i>	<i>OFF</i>	<i>OFF</i>	<i>OFF</i>	<i>OFF</i>	<i>OFF</i>
WAND	<i>OFF</i>	<i>OFF</i>	<i>OFF</i>	<i>OFF</i>	<i>OFF</i>	<i>OFF</i>

Table 5.1 Antenna Matching Chart



5.2 IV Mode

When configured as IV mode, SW1, SW2, SW3, SW4, and SW5 need to be set as follows:

SW1,2		DESCRIPTION
1,2	See Table 5.1	
3,4	See Table 5.1	
5,6	See Table 5.1	
SW3		
1	OFF See Note 3	Note 4: This is for interlock function. See Table 8.3. Note 6: This is a default setting for MASTER mode, see Table 8.3 for slaving
2	OFF See Note 4	
3	OFF See Note 4	
4	OFF See Note 6	
5	OFF See Note 6	
6	OFF See Note 6	
SW4		
1	OFF	Note 7: This is a default setting for MEDIUM detection, see Table 8.3 for different settings.
2	OFF	
3	ON	
4	OFF	
5	ON See Note 7	
6	OFF See Note 7	
SW5		
1	OFF See Table 8.3	Note 8: This is the default freq. band (7.6 – 8.7 MHz), see Table 8.3 for different bands.
2	OFF See Note 8	
3	OFF See Note 8	
4	OFF See Note 8	

Note 3: This is a default setting for Medium deactivation. (44 VDC at VPA TP2 for FCC, CE/UK compliance) For non- regulated market, please see Table 8.3 for the settings.

Table 5.2 Settings for IV Mode



INSTALLATION & TUNE-UP PROCEDURE

March 9, 2000

COUNTERPOINT IX

FCC ID: D04CP1900

5.3 V Mode

When configured as V mode, SW1, SW2, SW3, SW4, and SW5 need to be set as follows:

SW1,2		DESCRIPTION
1,2	See Table 5.1	
3,4	See Table 5.1	
5,6	See Table 5.1	
SW3		
1	OFF See Note 9	Note 10: This is for interlock function in IV mode Note 11: This is a default setting for MASTER mode, see Table 8.3 for slaving
2	OFF See Note 10	
3	OFF See Note 10	
4	OFF See Note 11	
5	OFF See Note 11	
6	OFF See Note 11	
SW4		
1	OFF	Note 12: Not used in V mode.
2	OFF	
3	OFF	
4	OFF	
5	N/A See Note 12	
6	N/A See Note 12	
SW5		
1	OFF See Table 8.3	Note 13: This is a default setting for MASTER mode, see Table 8.3 for slaving
2	OFF See Note 13	
3	OFF See Note 13	
4	OFF See Note 13	

Note 9: This is a default setting for Medium deactivation (44 VDC at VPA TP2 for FCC, CE/UK compliance)
For non- regulated market, please see Table 8.3 for the settings.

Table 5.3 Settings for V Mode



5.4 VI Mode

When configured as VI mode, SW1, SW2, SW3, SW4, and SW5 need to be set as follows:

SW1,2		DESCRIPTION
1,2	See Table 5.1	
3,4	See Table 5.1	
5,6	See Table 5.1	
SW3		
1	OFF See Note 14	Note 15: This is for interlock function. See Table 8.3. Note 16: This is a default setting for MASTER mode, see Table 8.3 for slaving
2	OFF See Note 15	
3	OFF See Note 15	
4	OFF See Note 16	
5	OFF See Note 16	
6	OFF See Note 16	
SW4		
1	ON	Note 18: This is for interlock function. See Table 8.3 for settings.
2	OFF	
3	N/A	
4	ON	
5	ON See Note 19	Note 19: This is a default setting for MEDIUM detection, see Table 8.3 for different settings.
6	OFF See Note 19	
SW5		
1	OFF See Table 8.3	Note 20: This is the default freq. band (7.6 – 8.7 MHz), see Table 8.3 for different bands.
2	OFF See Note 20	
3	OFF See Note 20	
4	OFF See Note 20	

Note 14: This is a default setting for Medium deactivation. (44 VDC at VPA TP2 for FCC, CE/UK compliance)
 For non- regulated market, please see Table 8.3 for the settings

Table 5.4 Settings for VI Mode



6.0 C/PT IX Tune Up and Test Procedure

If you haven't already done so, follow the standard procedure to tune the sensing system to Checkpoint's specifications **BEFORE** tuning the deactivators.

6.1 Center Frequency and Deviation Verify

Since the C/PT IX uses pulse-listen technology, it's difficult to measure the center frequency and the deviation using regular tools. Also, since the C/PT IX uses DDS (Direct Digital Synthesis), the frequency band can not be adjusted. Use dip meter and the ear phone to verify the center frequency and the deviation. You should hear the clicking sound with your earphone from 7.6 –8.7 MHz when you sweep the frequency using the dip meter. See Figure 8.1.

6.2 IV Mode

Follow step 5.2 to configure the chassis

Detection Field Adjustment

When in IV mode, the detection field should be adjusted properly to achieve the best performance.

To insure that tags will be detected before they are deactivated adjust R11 to its minimum setting which is approximately 0.7 VDC. See Figure 8.1.

Sensitivity adjustment

When in IV mode, the sensitivity of the receiver should be adjusted properly to achieve the best performance.

Adjust GAIN (R4) all the way clockwise (maximum) to achieve better detection. If phantoms occur, adjust GAIN (R4) counterclockwise slightly until the phantoms stop.

Test the detection height using standard 410 test tag. The detection height should be comparable to the numbers listed in Table 8.2. If the detection height is less than expected, go to Appendix A for the detailed tuning.

6.3 V Mode

Follow step 5.3 to configure the chassis. Test the deactivation height using live 410 tags. The deactivation height should be comparable to the numbers listed in Table 8.2. If the deactivation height is worse than expected, go to Appendix A for the detailed tuning.

**6.4 VI Mode**

Follow step 5.4 to configure the chassis. Test the deactivation height using live 410 tags. The deactivation height should be same or better compared to the numbers listed in Table 8.2. If the deactivation height is worse than expected, go to Appendix A for the detailed tuning. Test the detection height using standard 410 test tag, it should be at least 6" or higher if a pad is used.

6.5 Interlock Turn-On Time Adjustment

When the interlock function is used, adjust INT TIME (R98) clockwise to increase the interlock Turn-On time from 0.2 - 10 seconds in LO mode (SW3-3 OFF) and 1min - 10 min in HI mode (SW3-3 ON). See Figure 8.1.

7.0 After The Installation

Wait until after installation and tuning to show the customer personnel how the deactivator operates. Ensure that site management is present and let them designate which site employees will attend. If you have just installed a sensing system and deactivators, explain the sensing system operation first, then follow with the deactivator operations, as follows:

7.1 Turning the Deactivator On and Off

The deactivator should be turned off when not in use to prevent unauthorized personnel from deactivating tags.

Show the operation of the power switch, and point out the green light on the chassis, which shows that the power is on. If the sensing system control module is Model N or later, mention that a key is required to activate the system. If the sensing system is the master in a slaved configuration, indicate that it must be on before the deactivators will function.

7.2 How the Deactivator Works

Show how the deactivator operation is similar to the sensing system in that both systems transmit radio signals which cause tags to respond with their own radio signals when they come into range. Explain that each system's receiver recognizes the tag signal then verifies it. Then explain that the difference between the two is what each does with the verified tag signal. The sensing system alarms loudly upon tag verification. The deactivator alarms softly at the chassis and disables the tag. When deactivation is immediate, there will be no audible alarm.

7.3 When the Tag Doesn't Deactivate

Explain that tags vary in length of time required to deactivate. Some tags deactivate instantly, while others take longer. It may be that a very few wouldn't deactivate automatically. If this should occur, just place a Thank You label over the tag. Mention that any hard tags, hang tags, or non-deactivatable stickers also will not deactivate automatically. Clerks must either remove these tags, or mask them with a

Thank You label. For these tags, the deactivator acts as a point of sale detector. It continues to alarm softly until the tag is removed or masked.

7.4 When the Sensing System Alarms

Employees should follow their management's standard procedure for handling sensing system alarms, just as if there were no deactivators in the store. If there is no standard procedure, make a mental note to encourage management to set one. Wait until after you conclude the training meeting to avoid embarrassing management in front of the employees.

7.5 Testing the Deactivator

Employees should turn on the deactivator before use and turn off the deactivator when unattended. An employee verifies power by viewing the green light on the chassis. Beyond checking the power on switch, there isn't much need to test the deactivator's function because it will be immediately apparent should a unit fail to disable tags.

Show employees how to test for deactivation in case site management should want to test a unit. In IV and VI modes, use a hard tag, hang tag or non-deactivatable sticker. Hold it about 18" (46 cm) above each deactivator pad and bring it down slowly to the pad's surface. Point out alarm occurs at about 10.5" (27 cm) height. Take a deactivatable sticker and move it down in the same manner. Observe the signal stops as the tag gets closer. Try to alarm the deactivator again with the same tag to verify that it has been disabled. Make sure that this activity doesn't alarm any other deactivator or sensing system. In V mode, use DV1000 and live 410 tags to test the system.

7.6 Operational Problems

Give site management the telephone numbers used for calling Checkpoint service about equipment problems. Detail how to avoid potential problems by keeping permanent tags and stickers and also metal objects away from the deactivator pads.

7.7 Tagging

Show how deactivatable stickers can now be hidden in protected merchandise. Remind the customer that metal and foil objects usually can't be protected by pressure sensitive tags. Detail that all procedures for tagging merchandise covered in the User's Guide apply also to deactivatable tags. Detail the necessity of maintaining a tagging system, use of merchandise value or theft activity to decide which merchandise to tag, and the need for following an established procedure when the sensing system alarms.

8.0 Figures and Tables

8.1 Test Points and Adjustments

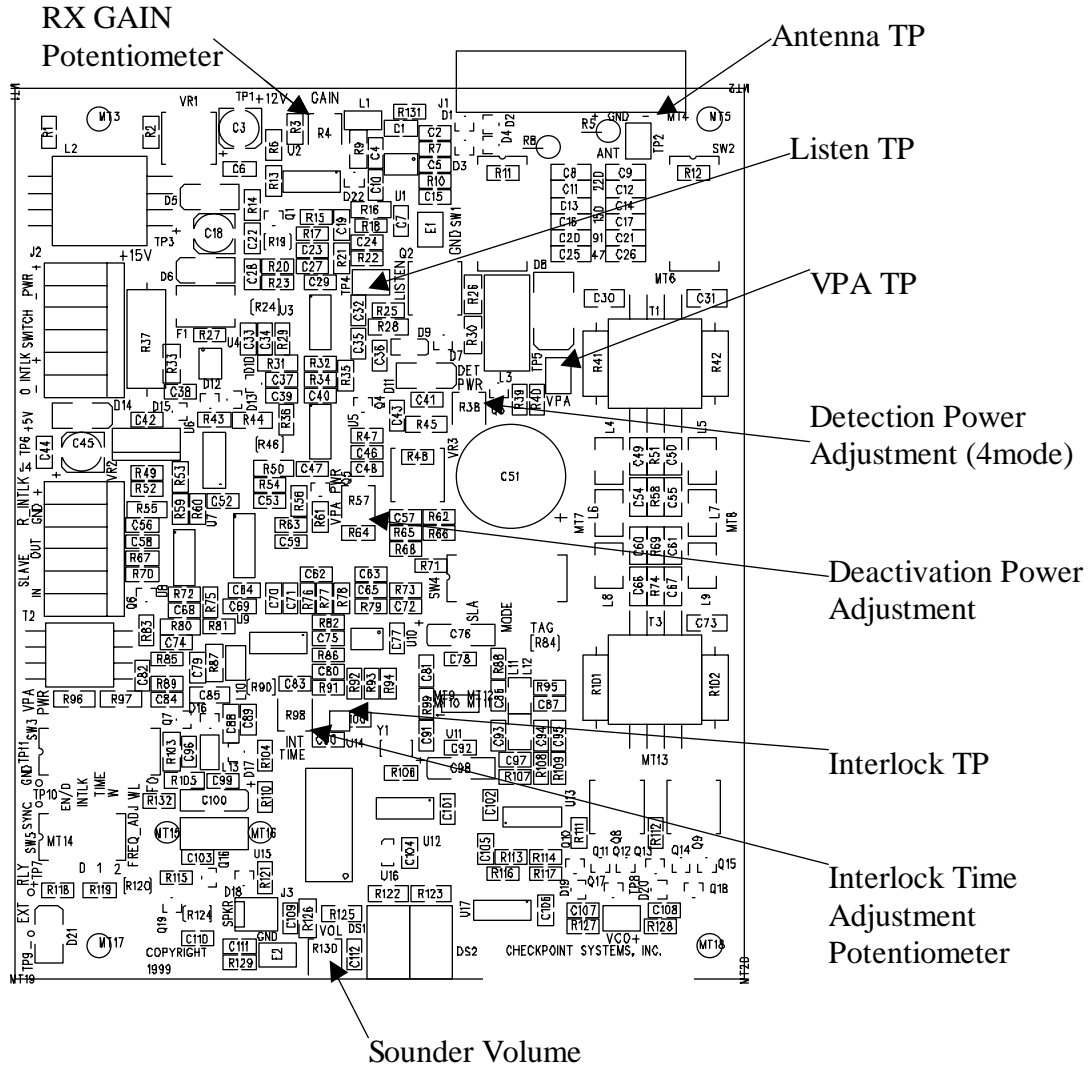

Figure 8.1 Test Points and Adjustment



TECHNICAL DOCUMENTATION

INSTALLATION & TUNE-UP PROCEDURE

March 9, 2000

COUNTERPOINT IX

FCC ID: D04CP1900

8.2

Slaving Decision Chart/All testing have been done with pads.

C/PT IX Slaving Decision Chart							
System	C/PT IX Power	C/PT IX Operating Mode					
		IV		V		VI	
		Slaved	Non-Slaved	Slaved	Non-Slaved	Slaved	Non-Slaved
Condor	Hi	15 ft	35 ft	20 ft	50 ft	20 ft	50 ft
	Med	15 ft	30 ft	20 ft	40 ft	20 ft	40 ft
	Low	15 ft	20 ft	20 ft	35 ft	20 ft	35 ft
QS4000	Hi	9 ft	9 ft	2 ft	4 ft	3 ft	4 ft
	Med	9 ft	9 ft	2 ft	3 ft	3 ft	3 ft
	Low	9 ft	9 ft	2 ft	3 ft	3 ft	3 ft
QS2000	Hi	8 ft	8 ft	2 ft	5 ft	2 ft	5 ft
	Med	8 ft	8 ft	2 ft	4 ft	2 ft	4 ft
	Low	8 ft	8 ft	2 ft	3 ft	2 ft	3 ft
QuickSilver	Hi	8 ft	8 ft	2 ft	5 ft	2 ft	5 ft
	Med	8 ft	8 ft	2 ft	4 ft	2 ft	4 ft
	Low	8 ft	8 ft	2 ft	3 ft	2 ft	3 ft
Inca	Hi	7 ft	7 ft	2 ft	5 ft	2 ft	5 ft
	Med	7 ft	7 ft	2 ft	4 ft	2 ft	4 ft
	Low	7 ft	7 ft	2 ft	3 ft	2 ft	3 ft
CP IV	Hi	7 ft	7 ft	13 ft	13 ft	13 ft	13 ft
	Med	7 ft	7 ft	7 ft	7 ft	7 ft	7 ft
	Low	7 ft	7 ft	4 ft	4 ft	4 ft	4 ft
CPV High Power	Hi	8 ft	8 ft	0 ft	0 ft	5 ft	5 ft
	Med	8 ft	8 ft	0 ft	0 ft	5 ft	5 ft
	Low	8 ft	8 ft	0 ft	0 ft	5 ft	5 ft
CP VI	Hi	18 ft	18 ft	1 ft	1 ft	6 ft	6 ft
	Med	18 ft	18 ft	1 ft	1 ft	6 ft	6 ft
	Low	18 ft	18 ft	1 ft	1 ft	6 ft	6 ft
C/PT IX in IV Mode	Hi	15 ft	15 ft	18 ft	18 ft	18 ft	18 ft
	Med	15 ft	15 ft	15 ft	15 ft	15 ft	15 ft
	Low	15 ft	15 ft	14 ft	14 ft	14 ft	14 ft
C/PT IX in V Mode	Hi	18 ft	18 ft	0 ft	0 ft	5 ft	5 ft
	Med	15 ft	15 ft	0 ft	0 ft	3 ft	3 ft
	Low	14 ft	14 ft	0 ft	0 ft	3 ft	3 ft
C/PT IX in VI Mode	Hi	18 ft	18 ft	5 ft	5 ft	5 ft	5 ft
	Med	15 ft	15 ft	3 ft	3 ft	3 ft	3 ft
	Low	14 ft	14 ft	3 ft	3 ft	3 ft	3 ft

Table 8.2 C/PT IX Slaving decision Chart



8.3 DIP Switch Settings

SW1,2	ON Position	OFF Position	Description				
1,2	220 pF enabled	220 pF disabled	Note: Use SW1 and SW2 to tune the antennas. Refer to Table 5.1 and Appendix A for the details				
3,4	150 pF enabled	150 pF disabled					
5	91 pF enabled	91 pF disabled					
6	47 pF enabled	47 pF disabled					
SW3	ON Position	OFF Position	Description				
1	ADJ. VPA (50–90V)	44V VPA	Use R57 to adjust VPA LO (0.2 – 10 sec), HI (1- 10 min) If no slave source is used 4,5, and 6 should kept OFF.				
2	Interlock enabled	Interlock disabled					
3	HI (Intlk. Time)	LO (Intlk. Time)					
4	Wire slave ON	Wire slave OFF					
5	Wireless slave ON	Wireless slave OFF					
6	Fiber slave ON	Fiber slave OFF					
SW4	1	2	3	4	5	6	Description
10Hz/ 16 pulse	OFF	OFF	---	---	---	---	10Hz is the average frequency when not slaved 164Hz is the average frequency when not slaved 2 tags in sequence 4 tags in sequence 16 tags in sequence
164Hz/ single pulse	ON	OFF	---	---	---	---	
Pulse Listen	N/A	ON	---	---	---	---	
4 Mode	---	---	ON	OFF	---	---	
5 Mode	---	---	OFF	OFF	---	---	
6 Mode	---	---	N/A	ON	---	---	
Fast Detection	---	---	---	---	OFF	OFF	
Medium Detection	---	---	---	---	ON	OFF	
Slow Detection	---	---	---	---	N/A	ON	
SW5	1	2	3	4			
Disable Dual Band	OFF	---	---	---	This feature is used to enable a second frequency band. Dual Band can't be used in the US. The software disables Dual band in 5Mode.		
Enable Dual Band	ON	---	---	---			
7.6 - 8.7 MHz	---	OFF	OFF	OFF	This is the default setting for the US.		
7.4 - 9.0 MHz	---	ON	OFF	OFF			
7.4 - 8.8 MHz	---	OFF	ON	OFF	This is the default setting for the Europe.		
7.8 - 9.4 MHz	---	ON	ON	OFF			
7.8 - 9.8 MHz	---	OFF	OFF	ON			
7.5 - 8.6 MHz	---	ON	OFF	ON			
7.7 - 8.8 MHz	---	OFF	ON	ON			
8.5 - 9.8 MHz	---	ON	ON	ON			

Table 8.3 DIP Switch Settings



8.4 INTERLOCK Time Adjustment Chart

The chart below specifies the voltage on the INTLK TP (Figure 8.1) to set the INTERLOCK time using INTERLOCK Adjustment potentiometer .

INTLK TP (Vdc +/-0.2Vdc)	INTLK TIME LO SW3-3 OFF	INTLK TIME HI SW3-3 ON
0.25	0.2 sec	1 min
0.75	1 sec	2 min
1.25	2 sec	3 min
1.75	3 sec	4 min
2.25	4 sec	5 min
2.75	5.5 sec	6 min
3.25	7 sec	7 min
3.75	8 sec	8 min
4.25	9 sec	9 min
4.75	10 sec	10 min

Table 8.4 INTERLOCK Time Adjustment Chart



8.5 Performance Matrix

SCANNER MGR.	ANTENNA NUMBER	C/PT IX - 4 Mode DETECTION	C/PT IX - 5/6 Mode DEACTIVATION
NCR			
7820	231088	3" - 4"	7-1/2" - 9"
7824	231088	3" - 4"	7-1/2" - 9"
7870	EAS ready	8-1/2" - 10"	13" - 15"
7875	EAS ready	6" - 8"	11" - 13"
Symbol			
LS5000-V	994026	6" - 8"	16" - 19"
LS5700	EAS ready	6" - 7"	13" - 15"
LS9100	076635	3" - 4"	4" - 5"
Spectra-Physics			
MAGELLAN	098409	4-1/2" - 6"	10" - 12"
MAGELLAN SL	EAS ready	4" - 6"	6" - 8"
VS1000	EAS ready	4-1/2" - 5-1/2"	8" - 10"
VS1000-Shroud	881777	6" - 8"	14" - 18"
HS1250	EAS ready	3-1/2" - 4"	6" - 8"
750F	231088	3-1/2" - 4-1/2"	8" - 9-1/2"
760SLS-M	881367	8" - 9"	15" - 18"
960LS	984483	4" - 5"	9" - 11-1/2"
ICL			
ORION	431727	9" - 10-1/2"	14" - 17"
MISC.			
CP WAND	076658	4-1/2" - 5-1/2"	5-1/2" - 6-1/2"
12 X 12 PAD	251281	8-1/2" - 9-1/2"	25" - 27"
LOW PROFILE	256279	7" - 8"	20" - 22"

V ---- Vertical H ---- Horizontal P ---- Plastic M ---- Metal W ---- Weigh Scale

Table 8.5 Performance Matrix

Appendix A Fine Tuning

DIP switch settings in Table 5.1 and Performance Matrix in Table 8.4 are based on the tests performed in the lab under following conditions:

1. Use of 6 feet, #18 cables for the scanners
2. Use of 8 feet, #18 cables for the pads
3. Free of any interfering RF systems in an open environment
4. Use of standard 410 test tag in V mode testing
5. Use of standard 410 tags in IV mode testing

In actual installation, these settings may be changed for proper performance of the C/PT IX due to environmental variations. If you are not able to tune the C/PT IX following the normal tuning procedure detailed in previous chapters, refer to this chapter for fine tunings.

A.1 Detailed Tuning in IV Mode

To fine tune the C/PT IX in IV mode, change switches SW1 and SW2 so that the average amplitude of the AC signal at ANT (TP2) is both maximized and as flat as possible. Start with SW1 and SW2 all off and turn on the DIP switches two at a time beginning at position (1). The following is an example of tuning 12 x 12 pad.

Scope Settings:

Ch1: Voltage: 5.00v/div Triggered on Ch1

Time: 50us/div

Test point: TP1

Maximized Intensity

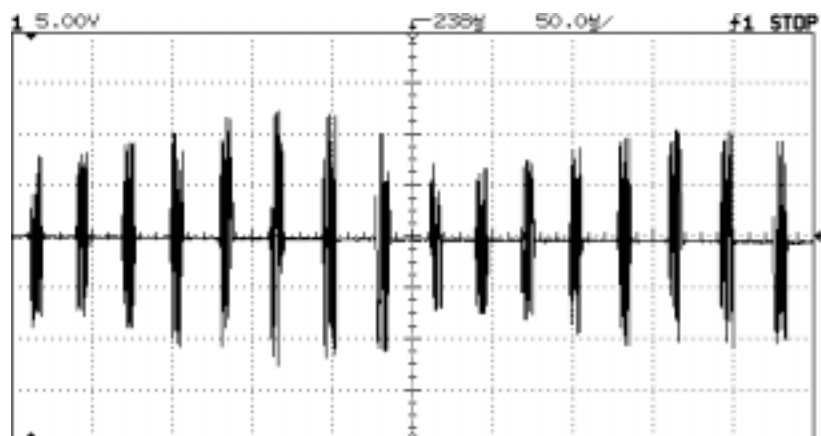

A1.1 AC Signal at ANT (TP2) with SW1, 2 (1) On

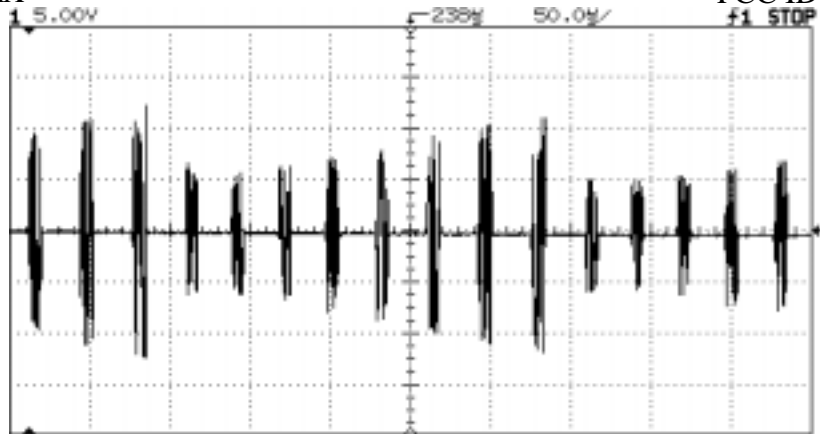

A1.2 AC Signal at ANT (TP2) with SW1, 2 (5,6) On

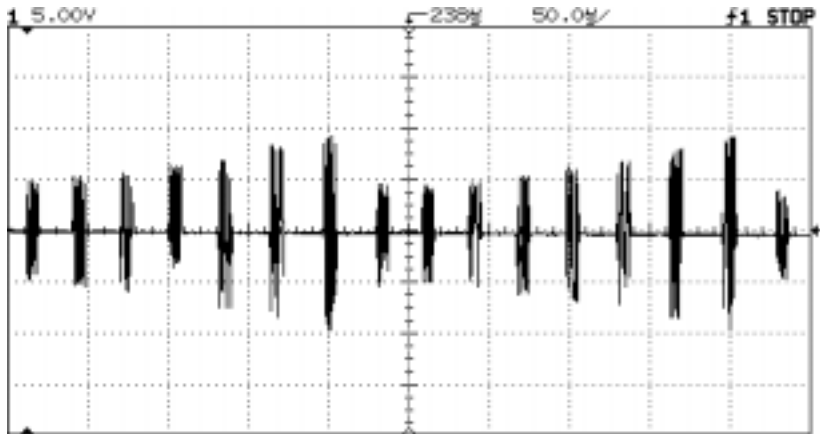

A1.3 AC Signal at ANT (TP2) with SW1, 2 (3,4,5,6) On

From A1.1 to A1.3 it's clear that SW1 and SW2 position (1) should be set to on (A1.1) for 12x12 pad because the average amplitude of the AC signal at ANT (TP2) is highest and more flat compared to the others.

**INSTALLATION & TUNE-UP PROCEDURE
COUNTERPOINT IX**

 March 9, 2000
 FCC ID: D04CP1900

If the C/PT IX phantoms, check the sensitivity as follows:

Scope Settings:

Ch1: Voltage: 100mv/div Triggered on Ch1
 Time: 200us/div
 Test point: LISTEN (TP4)
 Maximized Intensity

Ensure the peak amplitude of the AC signal without the tag at LISTEN (TP4) is below 0.5Vp-p as shown in A1.4.

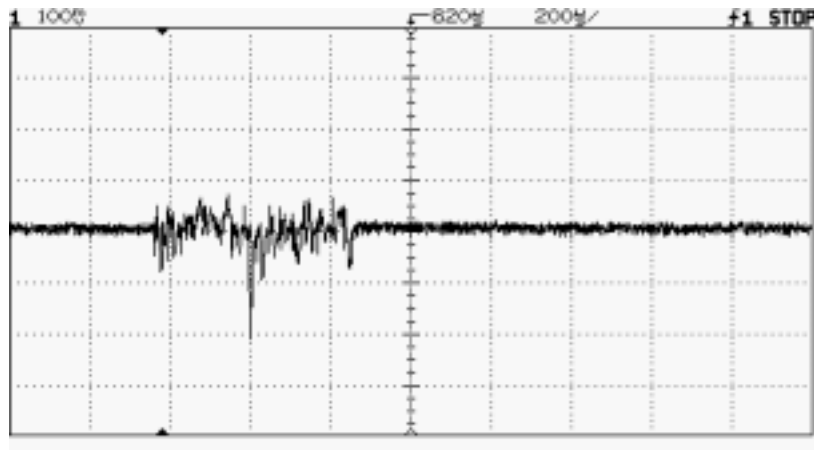
A1.4 AC Signal at LISTEN (TP4)

Readjust SW1 and SW2 if the signal at LISTEN (TP4) is over 0.5Vp-p.

A.2 Detailed Tuning in V Mode

Follow step A.1 to fine tune SW1 and SW2 without checking sensitivity.

A.3 Detailed Tuning in VI Mode

Follow step A.1 to fine tune the C/PT IX in VI mode for deactivation. If phantoms occur, reduce the sensitivity by adjusting GAIN (R4) counterclockwise all the way.