

# Classic Street



## Installation Manual

*Version \*60*



# Classic Street Installation Manual

Copyright © 2011 by Checkpoint Systems Inc.

Released XX/XX/2011.

Published by:

Checkpoint Systems Inc.

101 Wolf Drive

Thorofare, NJ 08086

## Document revision information

Classic Street Installation Manual, version \*60

Rev	Description	Date	Author
*60	CR2632	12/26/2011	Norman Wu, Chris Zheng

## Trademarks

Checkpoint is a registered trademark of Checkpoint Systems, Inc.

Checkpoint, Liberty, Evolve, and VisiPlus are registered trademarks of Checkpoint Systems, Inc. All rights reserved. Information in this document is subject to change without notice.

Other products © or ® their respective manufacturers or copyright holders.

Companies, names and data used in examples herein are fictitious unless otherwise noted. No part of the contents of this book may be reproduced or transmitted in any form or by any means without the written permission of the publisher.

## Copyright and Warranty Information

The information in this document is subject to change without notice.

Because of the changing nature of this product information presented in the Classic Street Installation Manual, Checkpoint Systems, Inc. is not liable for any omissions, misstatements, or other errors of information.

The information presented in this document may not be copied, used or disclosed to others for the purpose of procurement or manufacturing without the written permission of Checkpoint Systems, Inc. This guide and the products discussed in this guide are the exclusive property of Checkpoint Systems Inc. Copyright laws of the United States protect all information and products.

Copyright© 2011 Checkpoint Systems, Inc. All rights reserved.

## Important Information to our Users in North America

### FCC Regulatory Compliance Statement

Checkpoint Systems, Inc., offers Electronic Article Surveillance (EAS) or Radio Frequency Identification Products that have been FCC certified or verified to 47 CFR Part 15 Subparts B/C and/or 47 CFR Part 18. Appropriately, one of the following labels will apply to the approval:

NOTE: This equipment has been tested and found to comply with the limits for a class A digital device, pursuant to Part 15 of the FCC Rules. These limits are designed to provide reasonable protection against harmful interference when the equipment is operated in a commercial environment. This equipment generates, uses, and can radiate interference to radio communications. Operation of this equipment in a residential area is likely to cause harmful interference in which case the user will be required to correct the interference at his own expense.

- OR -

-

This device complies with Part 15 of the FCC Rules. Operation is subject to the following two conditions: (1) including this device may not cause harmful interference, and (2) this device must accept any interference received, including interference that may cause undesired operation, which may include intermittent decreases in detection and/or intermittent increases in alarm activity.

- OR -

-

NOTE: This equipment has been tested and found to comply with the limits for a miscellaneous type ISM device, pursuant to Part 18 of the FCC Rules. This equipment generates, uses, and can radiate radio frequency energy and, if not installed and used in accordance with the instruction manual, may cause harmful interference to radio communications. However, there is no guarantee that interference will not occur in a particular installation. If this equipment does cause harmful interference to radio communications reception, which can be determined by turning the equipment off and on, please contact Checkpoint Systems, Inc., at 1 (800) 257-5540 for further assistance.

### Industry Canada

Under Industry Canada regulations, this radio transmitter may only operate using an antenna of a type and maximum (or lesser) gain approved for the transmitter by Industry Canada. To reduce potential radio interference to other users, the antenna type and its gain should be so chosen that the equivalent isotropically radiated power (e.i.r.p.) is not more than that necessary for successful communication.

This radio transmitter (identify the device by certification number, or model number if Category II) has been approved by Industry Canada to operate with the antenna types listed below with the maximum permissible gain and required antenna impedance for

each antenna type indicated. Antenna types not included in this list, having a gain greater than the maximum gain indicated for that type, are strictly prohibited for use with this device

Operation is subject to the following two conditions: (1) this device may not cause interference, and (2) this device must accept any interference, including interference that may cause undesired operation of the device

To reduce potential radio interference to other users, the antenna type and its gain should be so chosen that the equivalent isotropically radiated power (e.i.r.p.) is not more than that permitted for successful communication.

## Industrie Canada

Conformément à la réglementation d'Industrie Canada, le présent émetteur radio peut fonctionner avec une antenne d'un type et d'un gain maximal (ou inférieur) approuvé pour l'émetteur par Industrie Canada. Dans le but de réduire les risques de brouillage radioélectrique à l'intention des autres utilisateurs, il faut choisir le type d'antenne et son gain de sorte que la puissance isotrope rayonnée équivalente (p.i.r.e.) ne dépasse pas l'intensité nécessaire à l'établissement d'une communication satisfaisante.

Le présent émetteur radio (identifier le dispositif par son numéro de certification ou son numéro de modèle s'il fait partie du matériel de catégorie I) a été approuvé par Industrie Canada pour fonctionner avec les types d'antenne énumérés ci-dessous et ayant un gain admissible maximal et l'impédance requise pour chaque type d'antenne. Les types d'antenne non inclus dans cette liste, ou dont le gain est supérieur au gain maximal indiqué, sont strictement interdits pour l'exploitation de l'émetteur

Le fonctionnement de l' appareil est soumis aux deux conditions suivantes:

1. Cet appareil ne doit pas perturber les communications radio, et
2. cet appareil doit supporter toute perturbation, y compris les perturbations qui pourraient provoquer son dysfonctionnement.

Pour réduire le risque d'interférence aux autres utilisateurs, le type d'antenne et son gain doivent être choisis de façon que la puissance isotrope rayonnée équivalente (PIRE) ne dépasse pas celle nécessaire pour une communication réussie.

## Equipment Safety Compliance Statement

Checkpoint Systems' EAS or Radio Frequency Identification products have been designed to be safe during normal use and, where applicable, certain components of the system or accessory sub-assemblies have been certified, listed or recognized in accordance with one or more of the following Safety standards: UL 1012, UL 1037, UL 1310, UL 60950-1, CSA C22.2 No. 205, CSA C22.2 No. 220, CSA C22.2 No. 223, CSA C22.2 No. 60950-1. Additional approvals may be pending.

**WARNING:** Changes or modifications to Checkpoint's EAS or Radio Frequency Identification (RFID) equipment not expressly approved by the party responsible for assuring compliance could void the user's authority to operate the equipment in a safe or otherwise regulatory compliant manner.

## Important Information to our Users in Europe CE Regulatory Compliance Statement

Where applicable, Checkpoint Systems, Inc., offers certain Electronic Article Surveillance (EAS) products that have CE Declarations of Conformity according to R&TTE Directive 99/5/EC.



System Electromagnetic Compatibility (EMC), has been tested and notified through Spectrum Management Authorities if necessary, using accredited laboratories, whereby, conformity is declared by voluntarily accepted European Telecommunications Standards Institute (ETSI) standards EN 301489-3 and EN 300330-2.

**NOTE:** Certain Electronic Article Surveillance (EAS) equipment have been tested and found to conform with the CE emission and immunity requirement in Europe. This equipment generates, uses, and can radiate radio frequency energy and, if not installed and used in accordance with the instruction manual, may cause harmful interference to radio communications. Under unusual circumstances, interference from external sources may degrade the system performance, which may include intermittent decreases in detection and/or intermittent increases in alarm activity. However, there is no guarantee that interference will not occur in a particular installation. If this equipment experiences frequent interference from external sources or does cause harmful interference to radio communications reception, which can be determined by turning the equipment off and on, please contact a Checkpoint Systems representative for further assistance.

## Equipment Safety Compliance Statement

Checkpoint Systems Electronic Article Surveillance products have been designed to be safe during normal use and, where applicable, certain components of the system or accessory subassemblies have been declared safe according to the European Low Voltage Directive (LVD) by being certified, listed, or recognized in accordance with one or more of the following European safety standards; EN 60950, EN 50364, EN 60742.

**WARNING:** Changes or modifications to Electronic Article Surveillance equipment not expressly approved by the party responsible for assuring compliance could void the user's authority to operate the equipment in a safe or otherwise regulatory compliant manner. Additional approvals may be pending.

# Table of Contents

---

TABLE OF CONTENTS.....	7
<b>INSTALLATION OVERVIEW .....</b>	<b>9</b>
OVERVIEW.....	9
REQUIREMENTS .....	9
<i>Tools</i> .....	9
<i>Parts</i> .....	10
INSTALLATION OUTLINE.....	10
<b>PHYSICAL INSTALLATION .....</b>	<b>11</b>
OVERVIEW.....	11
<i>Aisle Width</i> .....	11
POWER SUPPLY.....	11
<i>Placement</i> .....	11
ANTENNA MOUNTING .....	12
<i>Mounting Hardware</i> .....	12
<i>Wire Routing</i> .....	13
<b>ANTENNA WIRING .....</b>	<b>14</b>
OVERVIEW.....	14
GENERAL WIRING INSTRUCTION .....	14
<i>Wiring between PSB/SSB</i> .....	16
<i>Wiring 24VDC power supply</i> .....	17
SINGLE AISLE WIRING.....	18
<i>Secondary antenna (SSB) wiring</i> .....	19
<i>Primary antenna (PSB) wiring</i> .....	21
<b>ELECTRONICS SETTING .....</b>	<b>23</b>
OVERVIEW.....	23
<i>The Jumper setting for coupler aiming to antenna tuning</i> .....	23
<i>List of Ferrites for Classic Street</i> .....	24
<b>ANTENNA DIMENSIONS.....</b>	<b>25</b>
CLASSIC STREET PSB/SSB.....	25
<b>POWER SUPPLIES .....</b>	<b>26</b>
OVERVIEW.....	26
POWER SUPPLY USED IN UNITED STATES.....	26
POWER SUPPLY USED IN EUROPE.....	28

# CHAPTER

# 1

## INTRODUCTION

This Installation Manual details the steps necessary for the proper installation and configuration of the Classic Street systems.

In this manual, most illustrations and pictures will show the Classic Street as a place of reference, but it is to be understood that each antenna would be installed in the same manner (unless otherwise noted).



Classic Street front view



Classic Street Side view

**Figure 1 Classic Street antenna front and side view**



# CHAPTER

# 2

## INSTALLATION OVERVIEW

### Overview

---

This chapter is an overview of the installation process:

1. Requirements: Tool and part requirements for a typical installation.
2. Installation Outline: Lists the basic installation steps in sequence.

### Requirements

---

#### Tools

---

The following tools are required for Classic Street Antenna installations:

- Arrow T-25 Staple Gun
- Diagonal wire cutter
- Hammer drill with 3/16" and 1/2" bits
- Extension cord
- Tape Measure
- Hammer
- Marker, Black Felt
- Ratchet driver with 9/16" socket
- Screwdrivers, mini, regular and #2 Phillips
- Hacksaw
- Utility knife
- Wire Snake
- Wire Strippers
- Wrench, combination end 9/16"
- Classic Street Installation Manual (This manual)
- Tuning Procedure, TR4215 Checkpoint PN 7128336
- Checkpoint Systems Field Service Diagnostic Management Software (DMS version 1.8.31 or later version) installed on a laptop with the appropriate cables. DMS is an

application developed to install and configure TR4215 boards via serial connections. DMS provides for firmware updates without replacement of microchips.

## Parts

---

Quantity will vary according to site.

- 18 AWG 2-conductor (STP)
- CAT5e cable
- 22 AWG 4-conductor (STP) (5594)
- 1/2" Anchor Bolts
- \*DekDuct (wire chase)
- \*Wiremold (1500 or 2600 series)
- \*Wiremold anchor bolts Note:

\*Wire routing methods will vary by installation.

## Installation Outline

---

Follow this sequence to successfully install the components:

1. Determine optimal antenna placement based upon antenna type, tag type, and door opening width. (Refer to the TR4215 Product Reference Guide)
2. Determine power supply requirements and the ideal power supply location. (See "Appendix 2 Power Supplies")
3. Physically mount the antennas.
4. Connect the antenna wiring.
5. Install peripherals.
6. Configure the system using DMS.

The information covered in steps 1 and 2 is generally used during the survey and planning stage, but it is important for the installer to keep these specifications in mind to ensure that the systems are installed to specification.

## PHYSICAL INSTALLATION

### Overview

---

This chapter covers the physical placement and installation of the TR4215 antennas and power supply in the following sections:

1. Placement: How to determine the proper placement of the antennas.
2. Power Supply: Information on typical power supply placement.
3. Wire Routing: Information on typical wire routing methods.
4. Antenna Mounting: Antenna mounting information.

Note: For details of placement, refer to NGL installation manual, CKP P/N 7360602.

### Aisle Width

---

The maximum aisle width for the Classic Street antennas (with 410EP tag) is:

- Classic Street antennas (PSB/SSB) – 1.8 m [6 ft]

Classic Street antennas are composed of:

- Pedestal Classic Street NGL PSB (call it PSB for short, CKP P/N 10104118)
- Pedestal Classic Street NGL SSB (call it SSB for short, CKP P/N 10104133)

System performance is affected by aisle width and tag type. For aisle width details please refer to the TR4215 Product Reference Guide.

### Power Supply

---

Classic Street with coupler antennas utilizes a +24 VDC power supply.

### Placement

---

The power supply can be placed near the system, under a cashwrap counter, under shelving, above the drop ceiling (if using plenum-rated cabling), or in a nearby utility closet.

Placement Requirements:

- The power supply must be within 18m [60ft] of the furthest antenna.
- The power supply must be placed no higher than what is accessible from a store ladder.

- If mounted in a plenum space, proper plenum rated wiring and plenum rated enclosures are required.
- The maximum operation temperature should be no more than 40°C.

Note: For more information about power supplies, please see “Power Supplies” on Appendix 2.

## Antenna Mounting

---

Antennas are typically not mounted until after the finished flooring is in place.

### Mounting Hardware

---

#### ***For mounting on Concrete Floor***

Utilize two (2) 1.3cm [.5in.] anchor bolts per antenna.



**Figure 2 Anchor Bolt (Concrete Mounting)**

#### ***Wood Floor***

Utilize two (2) 1.3cm [.5in.] lag bolts per antenna.



**Figure 3 Lag Bolt (Wood Mounting)**

## Wire Routing

---

### **Methods of Wire Routing**

The cabling between PSB and SSB has to be routed either under floor or through floor wiremold. “Up & Over” routing method is not permitted for cabling between PSB and SSB.

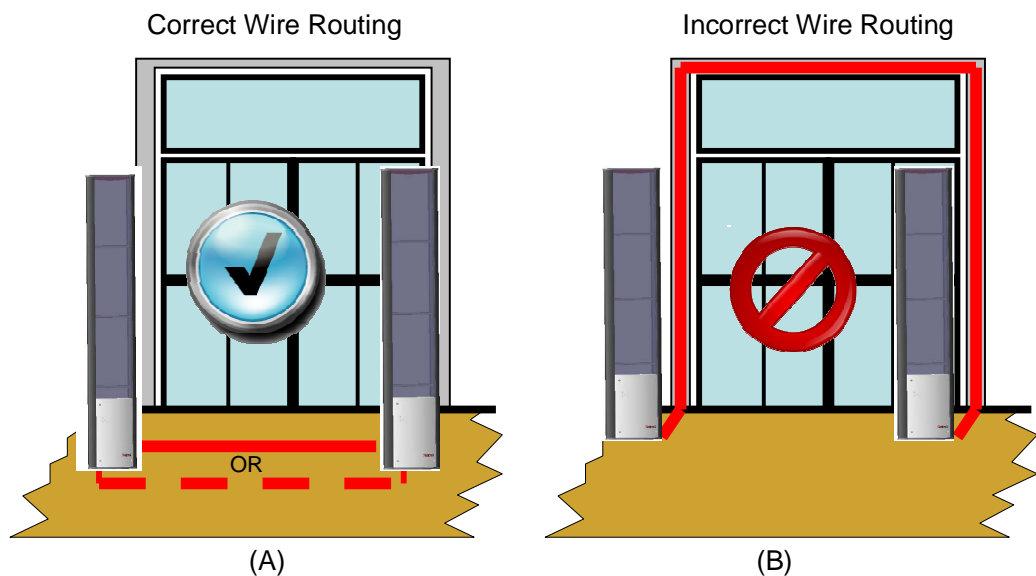

**Figure 4 Methods of Wire Routing**

- Floor Trench: Typically 1.3cm [.5in.] wide by 3.8cm [1.5in.], but an increase in dimensions is recommended for more than two antennas.
- Wiremold: 1500 or 2600 series wire mold can be utilized. Typically wire mold is not used within customer traffic areas, so a typical placement is from the outside of the antennas to the doorframe.
- Conduit: 2.5cm [1in.] diameter conduit can be utilized in new construction situations. It is recommended that swept 90 degree angles are used, and that pull-strings are provided by the conduit installer.
- Wall / Mullion: Wires can be contained within mullions, and hollow walls for vertical wire runs.
- Dek-Duct / Panduit: Wires can be contained within surface mount Dek-Duct or Panduit for vertical wire runs.

**WARNING:** Any wiring in plenum areas must be plenum rated. Additionally, ensure that the wire is installed in accordance with applicable (local/national) electrical codes.

# CHAPTER

# 4

## ANTENNA WIRING

### Overview

---

This chapter describes the Classic Street with Coupler primary (PSB) and secondary (SSB) antennas wiring and cabling.

**WARNING:** *This system runs on TR4215<sup>†</sup> electronics with firmware version 4.00 or higher. It is critical to note that ONLY TR4215 electronics can be used in conjunction with this system.* It is also critical that DMS version 1.8.31 or later be used to configure the system.

Information is covered in the following sections:

1. General wiring instruction
2. Aisle wiring

### General Wiring Instruction

---

This section describes how to prepare and wire all cables and wires involved in the antenna installation. Wires can be cut to required length. Below is a picture of a TR4215 board with all interfaces labeled.

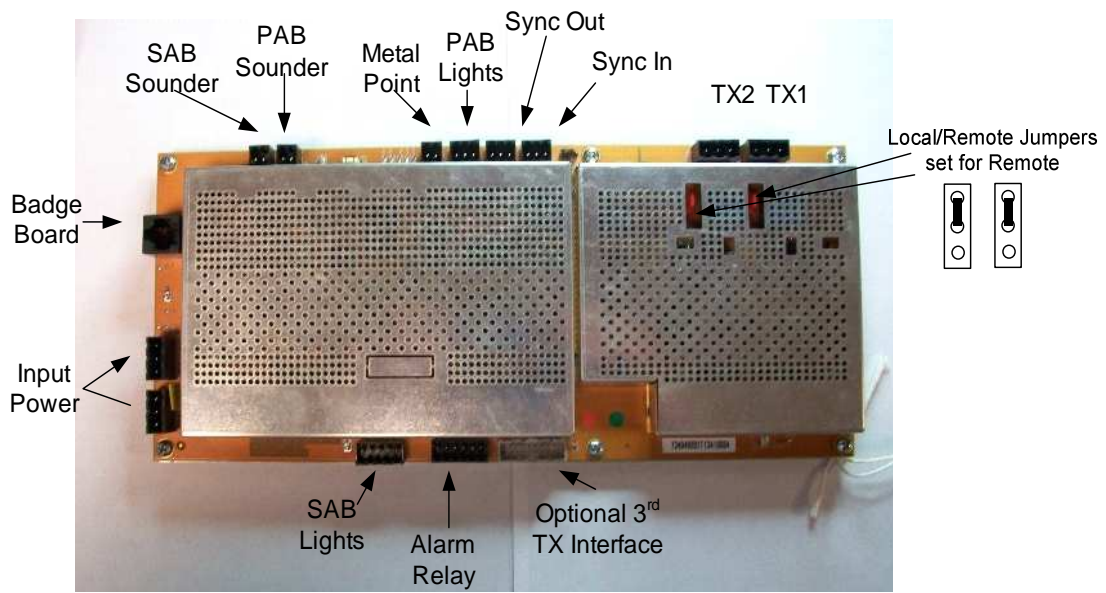

Figure 5 TR4215 Reader Board

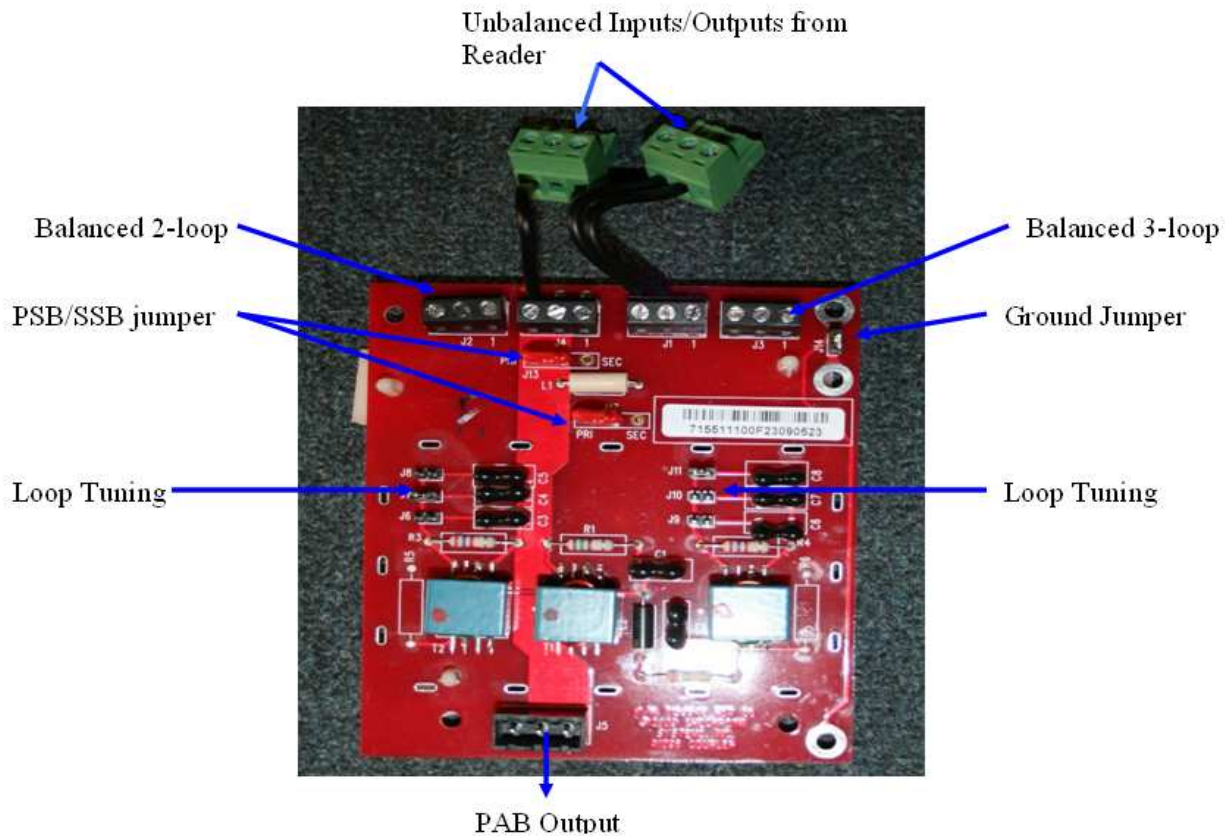

Figure 6 Passive Coupler Board

## Wiring between PSB/SSB

There are only two (2) wires connected between PSB and SSB. They are 1) RG59 coax cable and 2) SSB Light/Sounder cable (22 AWG 4-conductors (STP) (5594))

### RG59 Coax Cable:

A 13ft long, one end pre-terminated RG59 coaxial cable is packed with SSB antenna. It connects the coupler boards (J5) in the primary antenna (PSB) and in the secondary antenna (SSB). It is recommended to leave the pre-terminated end at the SSB. The installer has to terminate the other end at the primary antenna.

1. Strip the coax cable jack off for about 19mm [3/4in] at the un-terminated end, as shown in Figure 7 RG 59 Coax cable wiring diagram (A).
2. Separate and twist the shield braid tightly, leaving now loose strands.
3. Strip the center conductor to about 6 mm [1/4 in], insert it into connector pin #1, then tighten it with screwdriver.
4. Insert the twisted shield braid to the connector pin #2, and secure it with screwdriver.
5. Clamp 2 ferrite cores on each ends (PSB and SSB).
6. *Figure 7 RG 59 Coax cable wiring diagram (B)* shows the RG59 cable assembly been completely terminated with ferrite cores clamped on both ends.

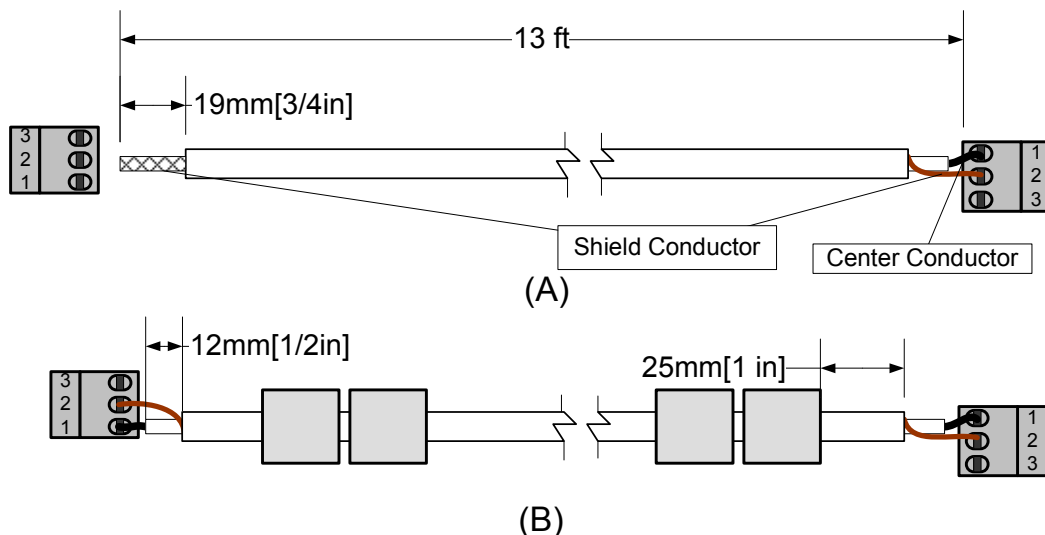

Figure 7 RG 59 Coax cable wiring diagram

### SSB Light/Sounder Cable

It is recommended to use CKP standard field service truck stock 4-conductor wire (AWG22). For the lights the white wire connects LT+ terminal and green wire connects LT- terminal. For the sounder the red wire connects to SD+ terminal and the black wire connects to the SD- terminal. The SSB light/sounder cable must mount a cylindrical ferrite at each end in PSB and SSB. A ferrite core with three turns is attached to each end.



SSB Light/Sounder Cable Wiring Table		
Wire Color	Primary Antenna (PSB)	Secondary Antenna (SSB)
WHITE	J41-5	LT+
GREEN	J41-4	LT-
RED	J54-1	SD+
BLACK	J54-2	SD-

**Table 1 SSB Light/Sounder Cable Wiring Table**

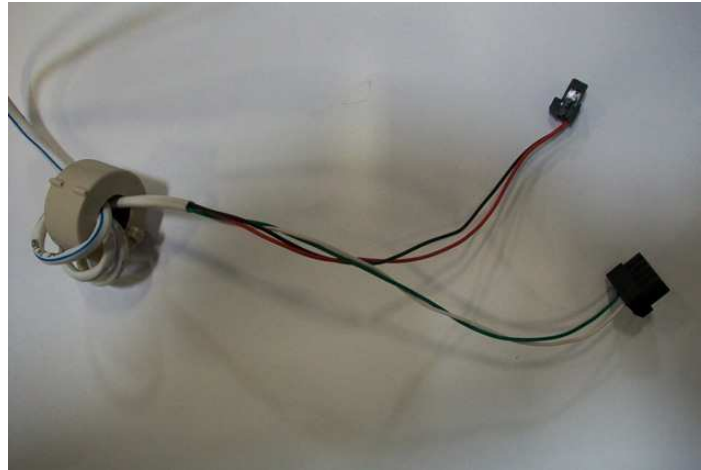

**Figure 8 SSB Light/Sounder cable with ferrite core.**

## Wiring 24VDC power supply

A Checkpoint certified 24VDC power supply can power up to two (2) PSBs. It is recommended to wire the 24VDC power supply to the nearer PSB filter board input, then, connect wire from this PSB's filter board to J18 connector on the reader. The other output from the filter board could be wired to other PSB filter board input. (See *Figure 10 24 VDC power filter*). 24VDC power cable uses AWG18 two (2) conductor cable.

Wire Color	Description
Black	GND
Red	+24 V

**Table 2 Power Cable Wiring Table**



**Figure 9 24 VDC Power Supply Cable**

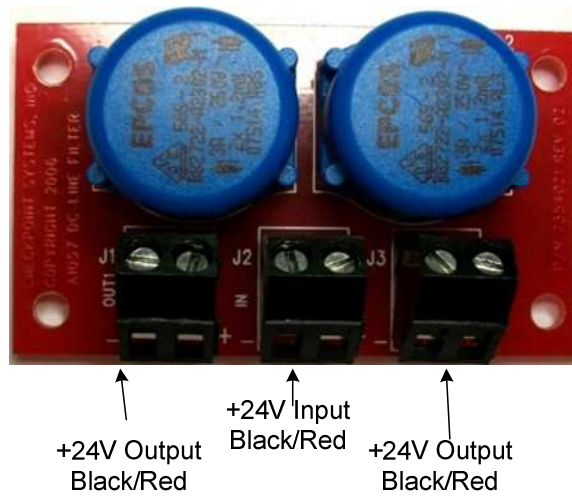
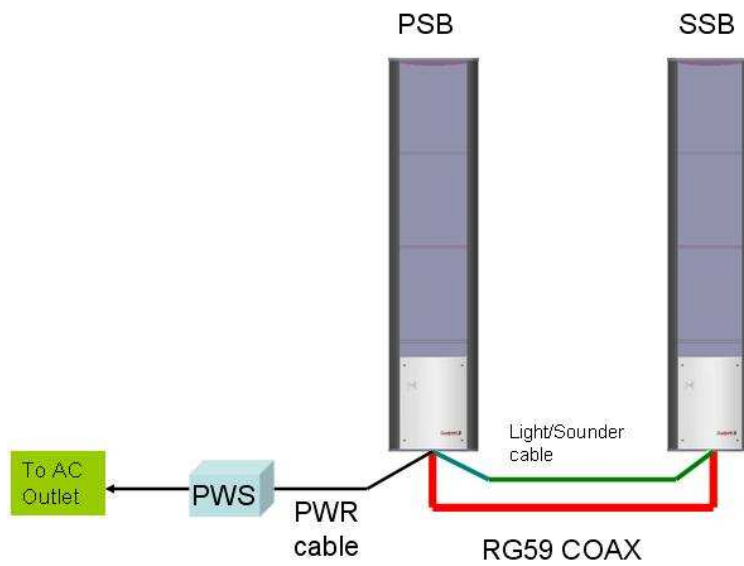

**Figure 10 24 VDC power filter**

## Single Aisle Wiring

---

The single aisle installation is the most common Classic Street application which best utilizes the PSB-SSB configuration (see *Figure 11 Single Aisle*). A typical single aisle installation consists of a Street primary antenna (PSB), a secondary antenna (SSB), a power supply and a cable kit (packaged with secondary antenna). It is recommended to start SSB wiring first, then wire the PSB. Connect the power cable last.



**Figure 11 Single Aisle**

## Secondary antenna (SSB) wiring

---

- Step 1:** Open the base cover.
- Step 2:** Plug the pre-terminated RG59 coax cable onto coupler board J5, then mount two (2) ferrite clippers close to the connector (see *Figure 7 RG 59 Coax cable wiring diagram*).
- Note:** It is recommended to leave the pre-terminated coax cable end at SSB location where the cable was laid out.
- Step 3:** Connect the SSB Lights/Sounder cable to the wire terminal LT+ (White) / LT- (Green) and SD+ (Red)/SD- (Black) resp.
- Step 4:** Inspect wiring and connections, confirm coupler board jumper settings (see *Figure 12 SSB Coupler Board Jumper Settings*).
- Step 5:** Put the base cover back and secure.

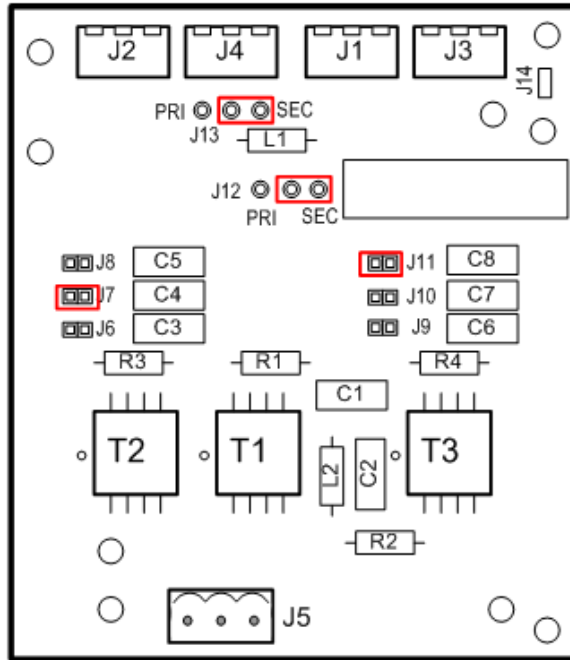

Figure 12 SSB Coupler Board Jumper Settings

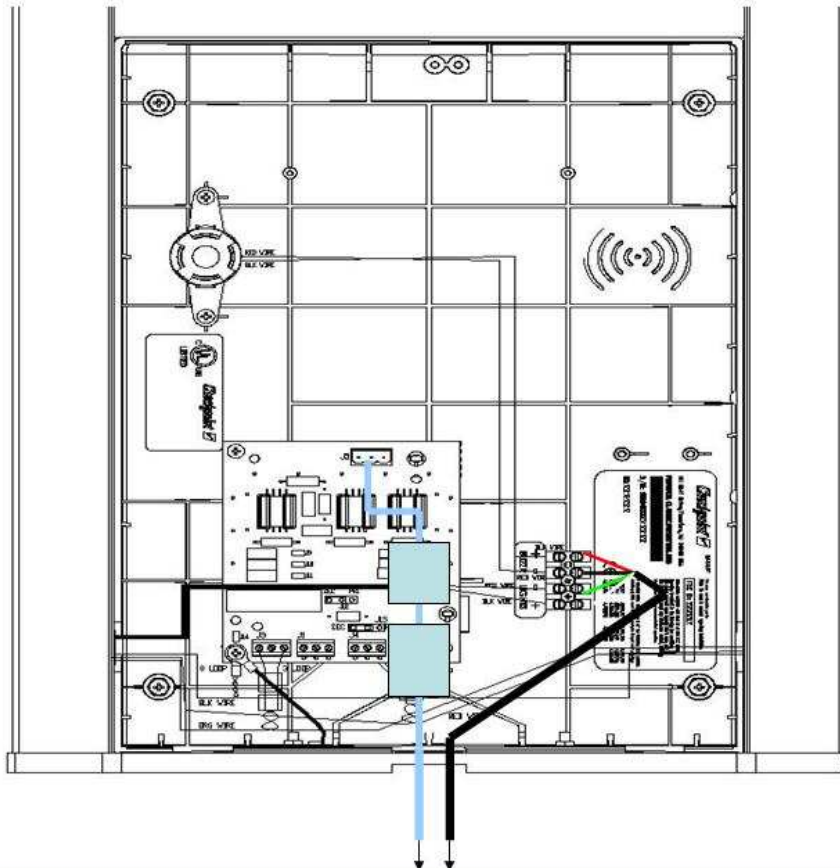

Figure 13 Classic Street SSB Antenna Wiring

## Primary antenna (PSB) wiring

- Step 1:** Open the base cover(s).
- Step 2:** Cut, strip and terminate the RG59 coax cable, then plug it to the coupler board. Check the coupler board jumper settings (see *figure 14 PSB Coupler Board Jumper Settings*).
- Step 3:** Connect the SSB Lights/Sounder Cable wires for the lights to the J41 on the electronic reader board (TR4215).
- Step 4:** Connect the SSB Lights/Sounder Cable wires for the sounder to J54 on the electronic reader board (TR4215).
- Step 5:** Connect 24v DC power cable to the VDC power filter and then the output of the filter board to J18 on the electronic reader board (TR4215).
- Step 6:** Inspect wiring and connections, confirm coupler board jumper settings (see *figure 14 PSB Coupler Board Jumper Settings*).
- Step 7:** Put the base cover(s) back and secure.

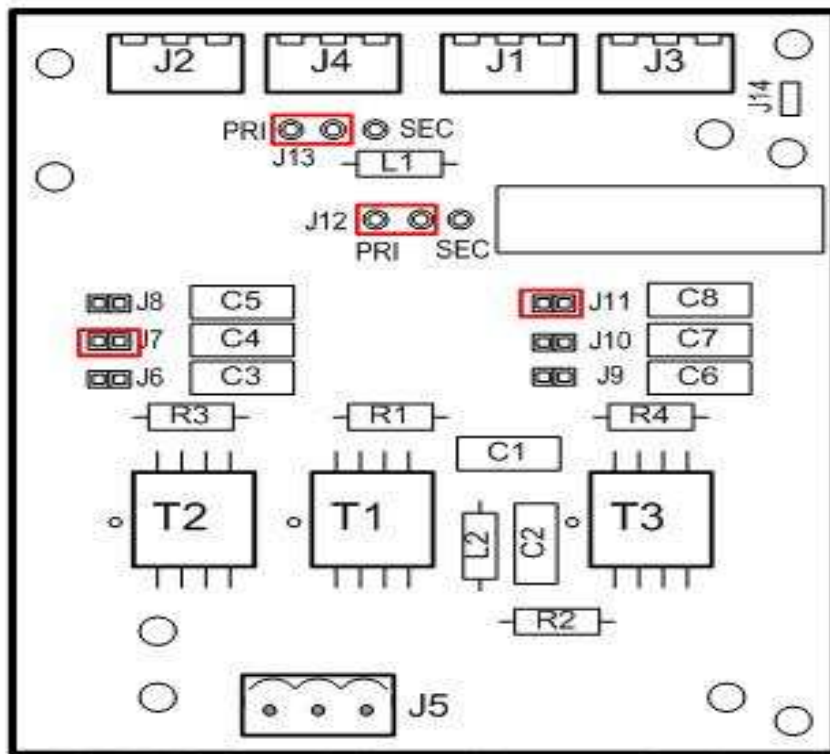

Figure 14 PSB Coupler Board Jumper Settings

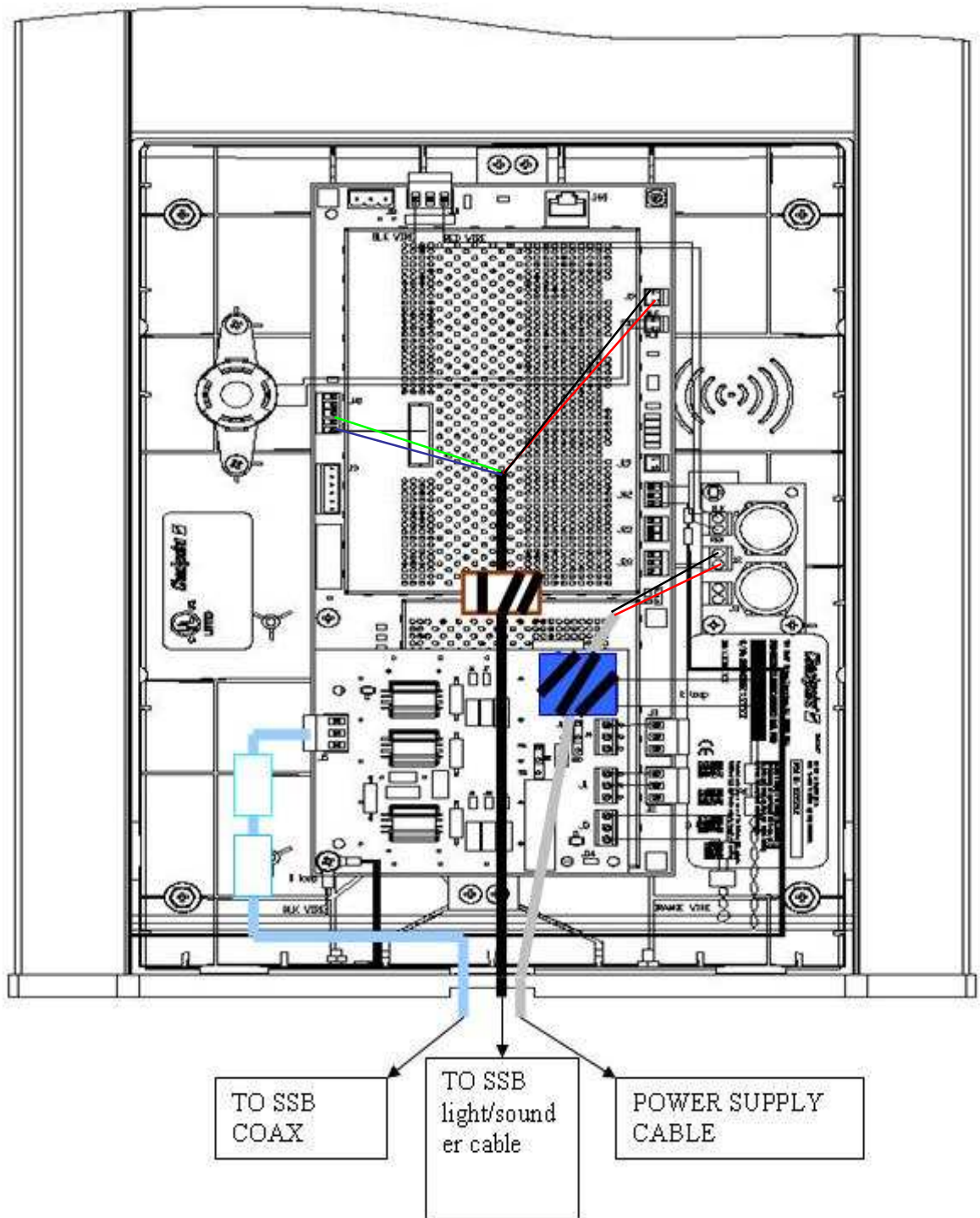

Figure 15 Classic Street PSB Antenna Wiring

# CHAPTER

# 5

## ELECTRONICS SETTING

### Overview

---

All electronics setting here aimed for on site configurations based on compliance and performance test result, If it sill can not illuminate fundamental noise, please refer to tuning procedure of TR4215 .

### The Jumper setting for coupler aiming to antenna tuning

Antenna Type	Jumper Settings
Classic Street	J7, J11

**Table 3: Coupler Board Jumper Settings**

## List of Ferrites for Classic Street

<b>Classic Street PSB</b>						
<b>CKP P/N</b>	<b>MFR</b>	<b>MFR &amp; MFR P/N</b>	<b># Turns</b>	<b>Cable installed on</b>	<b>install location</b>	<b>Qty</b>
7784420	Würth	WURTH 74271111	1	RG-59 COAX cable (both ends)	Liberty Coupler A1096	2
7284760	Fair Rite	FAIR RITE 0443806406	4	Pwr supply - dc cable	next to dc line filter pcb	1
7284760	Fair Rite	FAIR RITE 0443806406	4	LED+sounder cable	Next to terminal port of sounder and LED	1
617944	Fair-Rite	FAIR RITE 2843006802	1	LED cable to port J42	next to TR4215 / port J42	2
221412	Fair Rite	FAIR RITE 2861000202	1	Antenna Loop (2-Loop)	A1096 (J2)	2
221412	Fair Rite	FAIR RITE 2861000202	1	Antenna Loop (3-Loop)	A1096 (J3)	2
<b>Classic Street SSB</b>						
<b>CKP P/N</b>	<b>MFR</b>	<b>MFR &amp; MFR P/N</b>	<b># Turns</b>	<b>Cable installed on</b>	<b>install location</b>	<b>Qty</b>
7784420	Würth	WURTH 74271111	1	RG-59 COAX cable (both ends)	next to Liberty coupler	2
221412	Fair Rite	FAIR RITE 2861000202	1	Antenna Loop (2-Loop)	A1096 (J2)	2
221412	Fair Rite	FAIR RITE 2861000202	1	Antenna Loop (3-Loop)	A1096 (J3)	2
7284760	Fair Rite	FAIR RITE 0443806406	4	LED+sounder cable	close to 6- pin connector	1

**Table 5: Ferrites list for Classic Street**



# APPENDIX

# 1

## ANTENNA DIMENSIONS

### Classic Street PSB/SSB

---

The weight of the PSB antenna is 8.5kg, the SSB antenna is 8kg.

The dimension as following:

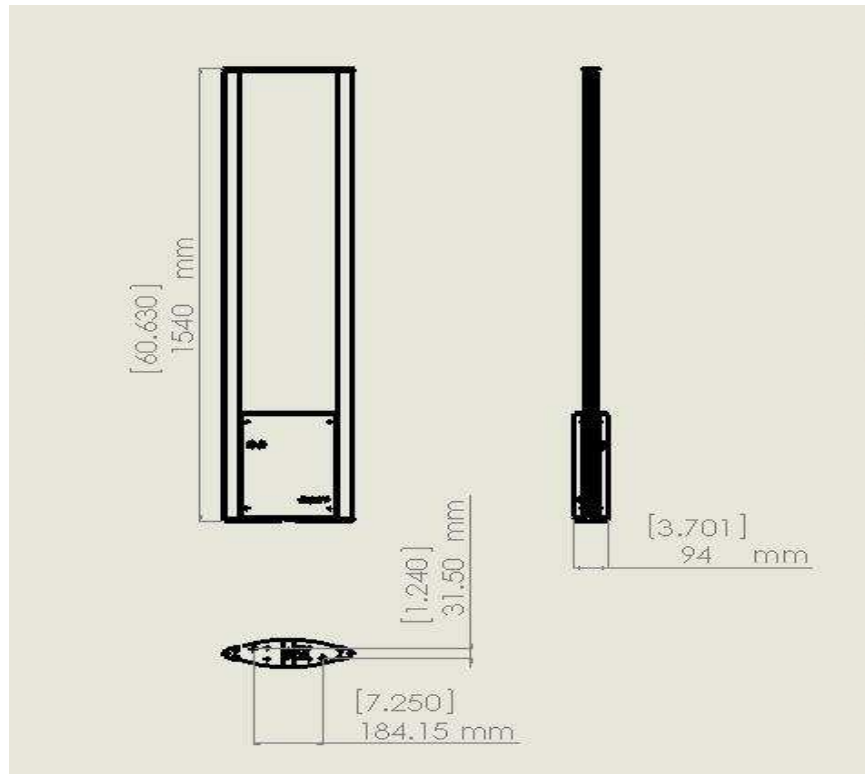

## POWER SUPPLIES

### Overview

---

This appendix covers all available (US and EU) TR4215 Street compatible power supplies.

#### Details

Power supplies have an output of +24 VDC.

#### Requirements

In the US, if the power supply is to be installed in a plenum (HVAC ventilation) area, the Globtek GS-599ES(R) and the Globtek GS-599MC-KIT(R) must be installed.

#### Capacity

The following power supplies can provide power for up to two aisle systems:

- Globtek GS-599 UF
- Globtek GS-599ES(R)
- EOS LFZVC65SG24E
- EOS- LFEVC65NS24PL (PN: 10102495)

The following power supply can provide power for one aisle systems:

- EOS LFZVC36FS24S91

### Power Supply Used in United States

---

#### Model

The US market uses the following power supply types:

#### 1. Globtek GS-599ES(R) (PN: 7116509)

Standard power supply rated for use in plenum areas.

**Note:** *For use in plenum areas, the Globtek GS-599MC-KIT(R) must be used in conjunction with the Globtek GS-599ES(R).*

#### Dimensions

Width: 10.50cm [4.13in]

Length: 15.24cm [6.00in]

Height: 8.64cm [3.40in]

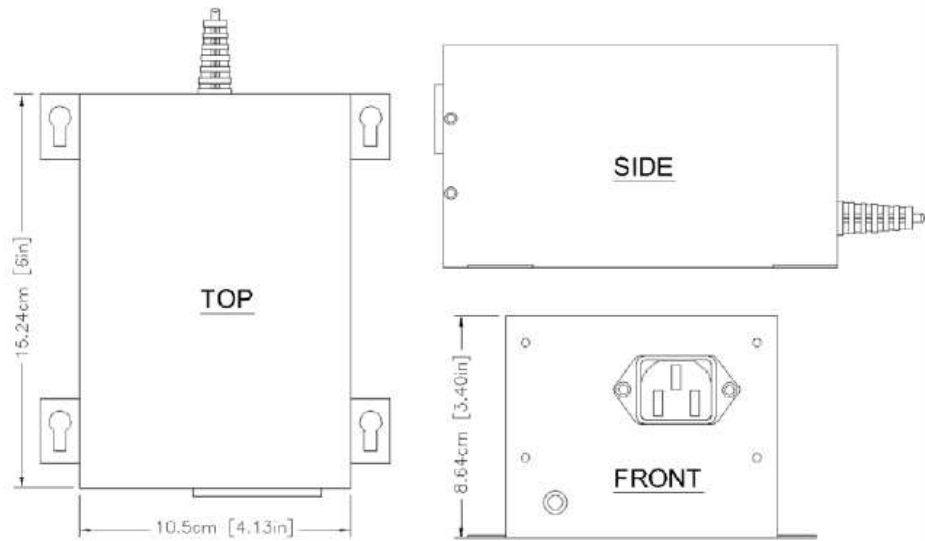

**2. EOS- LFEVC65NS24PL (PN: 10102495)**

**Note:**

**Dimensions**

- Width: 5.8 cm [2.284in]
- Length: 13.3 cm [5.236in]
- Height: 2.9 cm [1.152in]

**Weight**

350 grams (12.35 ounces)

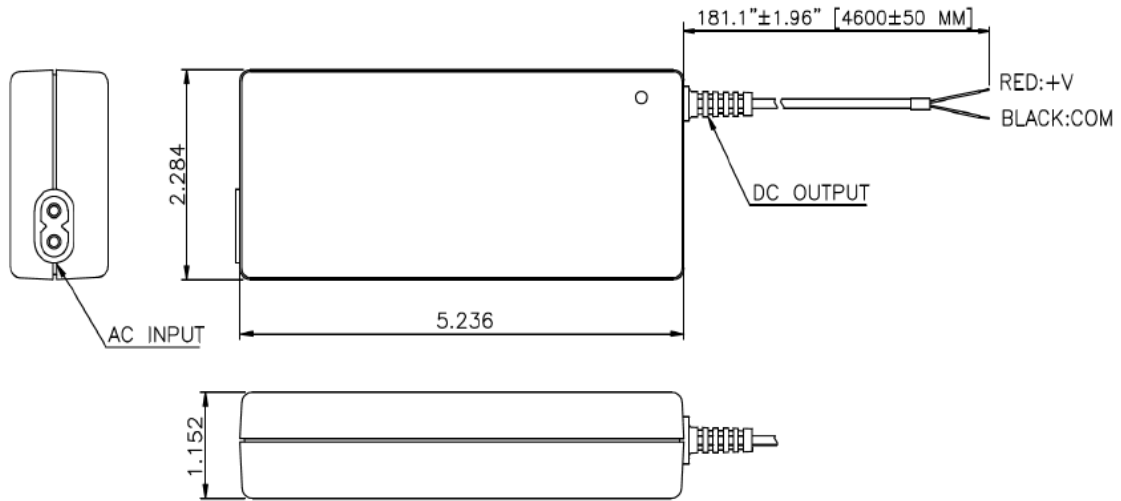

MECHANICAL OUTLINE DIMENSIONS  
 ALL DIMENSIONS ARE IN INCHES.  
 GEN TOLERANCE :+/-0.02

## Power Supply Used In Europe

### Model

The EU market uses one power supply types:

- EOS LFZVC36FS24S91 (PN: 7683707)

### Dimensions

Length: 8.89cm [3.50in]

Width: 2.42cm [0.95in]

Height: 4.47cm [1.75in]

