

SZU06A2 ZIGBEE WIRELESS COMMUNICATION MODULE



Product Manual



CHENGDU DIYUE TECHNOLOGY CO.,LTD.

Table of Contents

Table of Contents.....	1
1 General.....	1
1.1 Module introduction.....	1
1.2 Hardware description.....	1
2 Approvals.....	2
2.1 CE Approvals (ETSI).....	2
2.2 FCC Approvals.....	3
2.3 ATEX Approvals.....	4
3 Module Pinout.....	6
4 Hardware Description.....	8
4.1 Hardware Diagram.....	8
4.2 Interface characteristics.....	9
5 Absolute Maximum Ratings.....	10
5.1 Environmental characteristics.....	10
5.2 Recommended operating conditions.....	11
6 DC Electrical Characteristics.....	11
7 Digital IO Specifications.....	12
8 AC Electrical Characteristics.....	13
9 Physical Dimensions and Footprint.....	15
9.1 Physical Dimensions.....	15
9.2 Recommended Footprint.....	16
10 Soldering Temperature Time Profile (for reflow soldering).....	17
10.1 Recommended temperature time profile for lead-free solder.....	17
11 Reliability Test.....	18
12 Application Precautions.....	19
12.1 Safety precautions.....	19
12.2 Engineering design and using precautions.....	19

12.3 Storage conditions.....	20
13 Packaging.....	21
13.1 Carrier tape.....	21
13.2 Reel.....	22
14 Ordering Information.....	23
15 Drawing of Product Label.....	24
16 Disclaimer.....	25
17 RoHS Declaration.....	25
18 Data Sheet Status.....	25
19 Reference Documents.....	26
20 Contact Information.....	26



Module features

- Mini 33-pin stamp-like SMT package
- Provide on-board snake antenna
- Small form factor: 19 mm x 25 mm x 3.7 mm
- Compliant with EU CE certification
- Compliant with EU RoHS certification
- Compliant with EU ATEX certification
- Based on ARM Cortex[®]-M4 architecture
- 256K FLASH and 32K RAM
- Multiple sleep modes
- Operating voltage range: 2.1V to 3.9V
- Can act as End Device, Router or Coordinator
- Provide 8 GPIO lines
- Provide UART serial communication interface
- Firmware upgrade via serial port
- Hardware Supported AES-128 encryption
- Storage temperature range: -40°C to 125°C
- Operating temperature range: -40°C to 85°C
- Excellent anti-interference ability
- Outstanding networking stability
- Quick network data processing capability that collection of data from all nodes can be completed in 12 seconds in a ZigBee network composed of 100 nodes
- Serial data transmit-receive for end device in low power mode
- Remotely controlling other modules in the network with commands
- ZigBee channel scanning and PANID scanning
- Analyzing topology of current network with commands
- Updating the network key with commands
- Acquiring the neighbor table, routing table, and node information with commands
- Switching the current network channel with commands
- Providing abundant module registers for users to use and providing timers, interruptions etc. to execute users' built-in functions
- Scanning of ambient energy values to enable users to view jamming intensity of network channel signals
- ZigBee multicast function
- ZigBee binding function
- Providing DIYUE Terminal developed from the ZigBee PRO property set
- Standard JTAG or SWD programming and real-time online commissioning via IAR

RF Features

- Based on the Silicon Labs EFR32MG1 chip solution
- 2.4 GHz ISM frequency band
- 250 Kbps data transmission rate over the air
- 16 channels (IEEE802.15.4: CH11–CH26)
- Maximum output power: +8dbm
- Signal sensitivity: -98dBm@1% PER
- Sleep current: 2.7 μ A
- RX current :14mA
- TX current: 31mA @+8dBm
- Visible barrier-free communication distance: 600 m@-69dBm, PER=0.5‰

Applications

- Smart power grid
- Smart Energy
- Wireless alarm
- Safe home
- Smart household
- Smart building
- Smart agriculture
- Wireless sensor network
- M2M Industrial control
- Lighting, ventilation control
- Remote monitoring
- Environmental monitoring and control

Development kit

- Contain all of the platform which can quickly establish a simple Mesh network and evaluate SZU06A2 ZigBee wireless communication module performance
- AT-style software interface command dictionary can be modified for high volume customers.
- Custom software development available upon special request

1 General

1.1 Module introduction

SZU06A2 introduced in this document is an embedded wireless communication module based on IEEE802.15.4/ZigBee technology. The hardware has taken the EFR32MG1V132 chip solution of Silicon Labs and the software adopts the SZU06 AT instruction set self developed based on Ember Z-net_5.9.0 protocol stack released by Silicon Labs.

The advanced hardware design and the simple AT instruction interface enables SZU06A2 ZigBee wireless communication module to be blended into the wide range of applications.

Due to the strong configuration function of SZU06A2 AT instruction set, you can develop the products without extra MCU to save more time and cost. Besides, SZU06A2 ZigBee wireless communication module is also an ideal platform for development of ZigBee firmware apart from the use of customized firmware.

You can add the strong network function into your products without radio frequency experience or expertise, which can greatly shorten the research and development period of products and further speed up the marketing of the products.

1.2 Hardware description

SZU06A2 ZigBee wireless communication module is composed of the high performance and low power consumption RF chip EFR32MG1V132 from Silicon Labs, 38.4MHz system clock crystal oscillator, 32.768KHz monitoring clock oscillator and RF radio frequency front-end matching circuit which can optimize the radio frequency performance.

The module has been integrated a snake antenna on board, so that you can integrate it into your own products easily.

The maximum output power of RF chip is 8dBm, and the receive sensitivity is -100dBm typically.

Module	Chip	FLAH	RAM	Sealing Dimension
SZU06A2	EFR32MG1V132	256KB	32KB	19mm * 25mm * 3.7mm

Table 1- 1 Model of SZU06A2 Module

The SZU06A2 is used for ZigBee applications (www.zigbee.org). If you don't want to use the AT instruction interface we provided and expect to develop your own software, you need to download the official Simplicity Studio V4 development tool and Ember Z-net_5.9.0 or later protocol stack of Silicon Labs.

2 Approvals

2.1 CE Approvals (ETSI)

SZU06A2 ZigBee wireless communication module is certified CE by the following standards:

- EMC: Draft ETSI EN 301 489-1 V2.2.0:2017
Draft ETSI EN 301 489-17 V3.2.0:2017
- Radio: EN 300 328 V2.1.1:2016
EN 62479:2010
- Safety: EN 60950-1:2006/A11:2009/A1:2010/A12:2011/A2:2013

When SZU06A2 ZigBee wireless communication module is embedded into an OEM product, it is prohibited to declare that his OEM products comply with CE certification in the name of approved CE certification of our company. If the OEM manufacturer wants to declare that his final products comply with CE certification, it must be ensured that the final products shall comply with the European EMC, Radio and Safety standards. Otherwise, ChengDu DiYue Technology Co., Ltd. has the right to investigate and affix the responsibility for it.

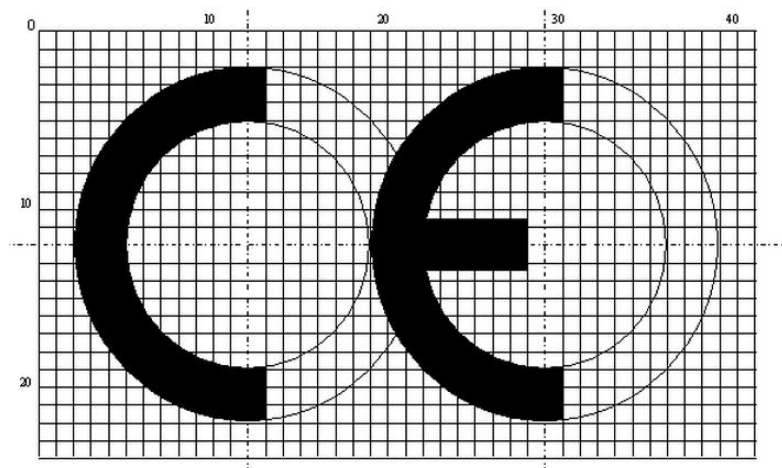

The "CE" marking must be placed in a prominent position of OEM products. Please refer to <http://ec.europa.eu/enterprise/faq/ce-mark.htm> for more information about CE certification mark.

2.2 FCC Approvals

The SUZ06A2 ZigBee wireless communication module has been tested to comply with **Part 15 of the FCC rules**.

FCC caution:

This device complies with Part 15 of the FCC rules. Operation is subject to the following two conditions: (1) this device may not cause harmful interference, and (2) this device must accept any interference received, including interference that may cause undesired operation.

Note:

This equipment has been tested and found to comply with the limits for a Class B digital device, pursuant to Part 15 of the FCC Rules. These limits are designed to provide reasonable protection against harmful interference in a residential installation. This equipment generates, uses and can radiate radio frequency energy and, if not installed and used in accordance with the instructions, may cause harmful interference to radio communications. However, there is no guarantee that interference will not occur in a particular installation. If this equipment does cause harmful interference to radio or television reception, which can be determined by turning the equipment off and on, the user is encouraged to try to correct the interference by one or more of the following measures:

- Reorient or relocate the receiving antenna.
- Increase the separation between the equipment and receiver.
- Connect the equipment into an outlet on a circuit different from that to which the receiver is connected.
- Consult the dealer or an experienced radio/TV technician for help.
- Please take attention that changes or modification not expressly approved by the party responsible for compliance could void the user's authority to operate the equipment.

FCC RF EXPOSURE STATEMENT:

The device has been evaluated to meet general RF exposure requirement, The device can be used in portable exposure condition without restriction.

2.3 ATEX Approvals

The SZU06A2 ZigBee wireless communication module has been tested to comply with the ATEX 2014/34/EU regulation about explosion proof products. Intended Use: Zone 2 GAS.

This device meets the following parameters:

$U_i=3.9V$, $I_i=1A$, $P_i=0.98W$, $C_i=15.32\mu F$, $L_i=5.64\mu H$, $-40^\circ C \leq T_s \leq 80^\circ C$

And it complies with the following standard:

- EN 60079-0:2012+A11:2013
- EN 60079-11:2012

Ex marking:



Certificate number:

TPS 17 ATEX 93558 006 U

When installing the SZU06C1 module into your own product and requiring explosion protection, please make sure that your product must meet the above explosion-proof parameters and indicate "Transceiver Module II 3G Ex ic IIC Gc" or similar words outside the final product.

Name And Address Of Notified Body: TÜV SÜD Product Service GmbH
Zertifizierstellen
Ridlerstraße 65
80339 MÜNCHEN
GERMANY

Number Of Notified Body: 0123

Special conditions for safe use:

1. The sign “U” placed after the certificate number indicates that the certificate must not be mistaken with a certificate intended for an equipment or protective system. This partial certification may be used as a basis for certification of equipment or protective system.
2. The maximum input parameters stated above shall be considered during installation. The rules for interconnection of intrinsically safety circuits according EN 60079-11 and EN 60079-14 have to be taken into account.
3. The maximum service temperature of the communication module when incorporated into apparatus is -40°C to +80°C. When utilized at this service temperature, a T4 temperature classification is suitable.
4. The communication module shall be installed in an enclosure that provides a minimum ingress protection of IP20.

3 Module Pinout

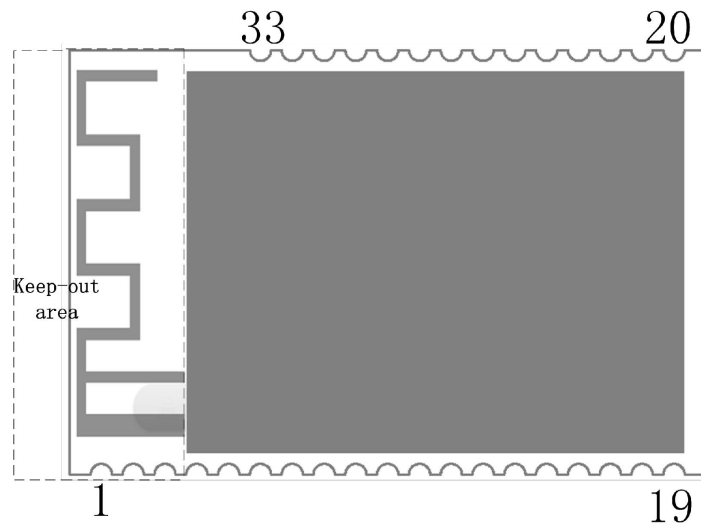

Fig. 3-1 SZU06A2 Pinout (top view)

In order to facilitate the user to develop and design the products based on SZU06A2 ZigBee wireless communication module, we have detailed the pin information of SZU06A2 ZigBee wireless communication module in the following Table 3-1.

All GND pins are directly connected with the module; but for best RF performance, each GND pin shall be connected to a complete ground externally .

Pin No.	Pin Name	Chip Pin	IO Characteristic	Function Description
1	GND	GND	-	System GND.
2	NC	-	-	Float directly.
3	NC	-	-	Float directly.
4	D0	PD13	RW	General GPIO
5	D1	PD14	RW	General GPIO
6	D2	PD15	RW	General GPIO
7	RESETn	RESETn	-	System Reset,see note 1
8	NC	-	-	Float directly.
9	NC	-	-	Float directly.
10	NC	-	-	Float directly.
11	NC	-	-	Float directly.

12	NC	-	-	Float directly.
13	GND	GND	-	System GND.
14	PTI.SYNC	PB13	R/RW	General GPIO
15	PTI.DATA	PB12	R/RW	General GPIO
16	PTI.CLK	PB11	R/RW	General GPIO
17	TXD	PA0	R/RW	Transmitted Data
18	RXD	PA1	R/RW	Received Data
19	GND	GND	-	System GND.
20	GND	GND	-	System GND.
21	TCK_SWCLK	PF0	-	Test Clock signal
22	TDO_SWO	PF2	-	Test Data Out
23	TDI	PF3	-	Test Data In
24	TMS_SWDIO	PF1	-	Test Mode signal
25	NC	-	-	Float directly.
26	NC	-	-	Float directly.
27	D3	PC0	R/RW	General GPIO
28	D4	PC1	R/RW	General GPIO
29	NC	-	-	Float directly.
30	NC	-	-	Float directly.
31	GND	GND	-	System GND.
32	VCC	VCC	-	System Power Supply,see
33	GND	GND	-	System GND.

Table 3- 1 Description of SZU06A2 Pinout

Notes:

①Low level is adopted for system reset. In case of nRESET='0', the module is staying in reset state, and the low level time should be longer than 20 μ s.

②System power supply range: 2.1V-3.9V.

4 Hardware Description

4.1 Hardware Diagram

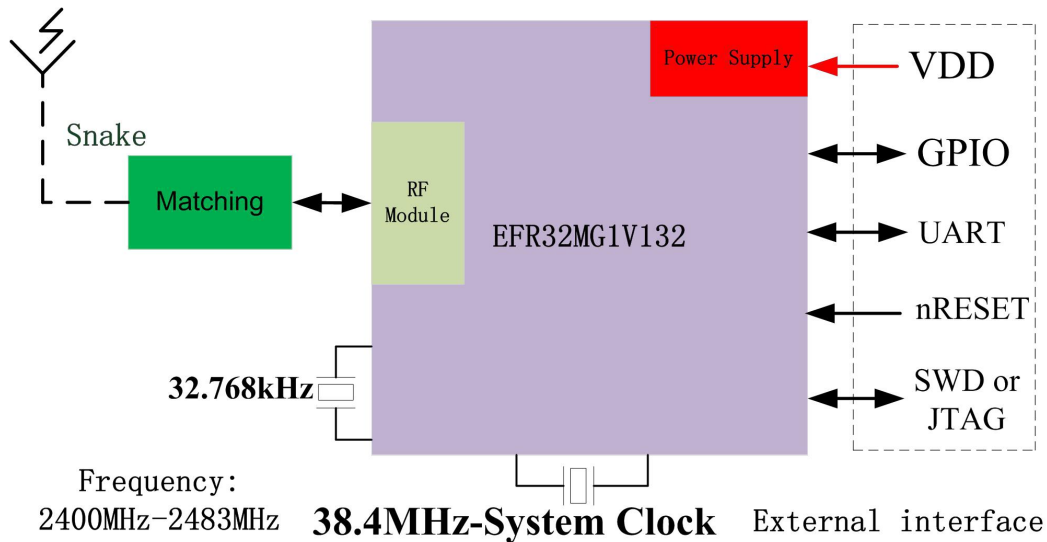

Fig. 4-1 Hardware Diagram of SZU06A2

SZU06A2 wireless communication module is based on EFR32MG1V1321 chip from Silicon Labs, which integrates the RF transceiver complying with 2.4-GHz IEEE 802.15.4, high performance 32-bit ARM Cortex®-M4 CPU, 256KB FLASH and 32KB RAM which can be programmed in the system and many other peripherals with strong functions. In addition, the EFR32MG1V132 has multiple sleep modes, which makes it to be more adaptable to the ultra-low power consumption system. It only takes a few milliseconds for change between different power modes that further ensures the low power consumption of the equipment.

SZU06A2 wireless communication module provides 8-lines GPIO, one UART communication interface, two debug interface (one is 2-wire SWD and the other is 4-wire JTAG). And you can develop your custom software easily with them.

In addition to this a number of MAC functions are also implemented in hardware to help maintain the strict timing requirements imposed by the ZigBee and IEEE802.15.4 standards.

4.2 Interface characteristics

Parameter	Test conditions	Minimum value	Typical values	Maximum value	Unit
UART Baud Rate		9600		115200	bps
Analog channel resolution	Half-duplex	6		12	bit
Analog input impedance			20		kΩ
Analog input voltage		2.1	3.3	3.9	V
GPIO output voltage		-0.3		3.9	V
Real-time clock frequency			32.768		kHz

Table 4-1 SZU06A2 Interface Characteristics

5 Absolute Maximum Ratings

Parameter	Symbol	Min value	Max value	Unit	Note
Supply voltage	V_{DD}	-0.3	3.9	V	
Supply current	I_{VDD}	-	1000	mA	
Pin voltage	V_{PIN}	-0.3	3.9	V	
RF input level	P_{max}	-	10	dBm	
Output power	P_{out}	-26	8	dBm	
Storage temperature range	T_{stg}	-40	125	°C	
Operating temperature range	T_{op}	-40	85	°C	
Reflow temperature	T_{death}		245	°C	Lead-free soldering

Table 5-1 Limit Parameter

Notes:

The limit values given in Table Table 5-1 shall not be exceeded under any condition and exceeding any one of the limit values may cause permanent damage to the device.

5.1 Environmental characteristics

Parameter	Symbol	Absolute maximum ratings	Unit	Note
ESD1	V_{THHBM}	±2	KV	Description of human-body mode circuit
ESD2	V_{THCDM}	±500	V	Description of charged device model
Humidity level	MSL	MSL3	-	

Table 5-2 Environmental Parameters



Notes:

Caution! ESD sensitive device. Precautions should be used when handling the device in order to prevent permanent damage.

5.2 Recommended operating conditions

Parameter	Min value	Typical value	Max value	Unit	Environment
Supply voltage	2.1	3.3	3.9	V	
RF input power	-	-	10	dbm	
RF frequency	2405		2480	MHz	
Operating temperature	-40	25	85	°C	-
Relative humidity	-	-	95	%	

Table 5-3 Recommended Operating Conditions

6 DC Electrical Characteristics

$V_{DD} = 3.3V, T_{OP} = 25^{\circ}C, f_C = 2400MHz - 2483.5MHz.$

Parameter	Test condition	Symbol	Value		
			Min.	Type	Max.
Supply Voltage		V_{DD}	2.1V	3.3V	3.9V
Supply Current		I_{VDD}	-	-	1000mA
Reset		I_{reset}		2.1mA	3mA
	Hard reset	t_{reset}		1ms	
FLASH	FLSH erase	C_{erase}	10000	-	-
	Flash data retention	$t_{retention}$	10years	-	-
	Page erase	t_{erase}	20ms		40ms
		I_{read}	-	-	3mA
	Write operation	I_{write}	-	-	3mA
RX Current	Receive enable	I_{RX}	-	14mA	14.2mA
TX Current	TX power = 0dBm	I_{TX}	-	15mA	16.7mA
	TX power = 3dBm		-	20.2mA	21mA
	TX power = 8dBm		29mA	31.2mA	32mA
Sleep Current	Enter EM2 mode	I_{sleep}	2.3μA	2.7μA	3.2μA
	Enter EM3 mode		-	1.7μA	-
	Enter EM4 mode		-	0.5μA	-
Wake up time	From EM1 to wake	t_{em1-wu}	-	3μs	-

	From EM2 to wake	$t_{em\ 2-wu}$	-	3 μ s	-
	From EM3 to wake	$t_{em\ 3-wu}$	-	3 μ s	-
	From EM4H to wake	$t_{em\ 4h-wu}$	-	20 μ s	-
	From EM4S to wake	$t_{em\ 4s-wu}$	-	290 μ s	-

Table 6-1 DC Electrical Characteristics of SZU06A2

7 Digital IO Specifications

$V_{DD} = 3.3V, T_{OP} = 25^{\circ}C$.

Parameter	Test conditions	Sym	Parameter value		
			Min.	Typ.	Max.
Logic0 input voltage		V_{IL}			0.3* V_{DD}
Logic1 input voltage		V_{IH}	0.7* V_{DD}		
Logic0 input current	Input voltage 0V	I_{IL}	-	0.1nA	30nA
Logic1 input current	Output voltage V_{DD}	I_{IH}	-	0.1nA	50nA
I/O-pin pullup resistors		R_{PU}	30k Ω	43k Ω	65k Ω
I/O-pin pulldown resistors		R_{PD}	30k Ω	43k Ω	65k Ω
Logic0 output voltage, 3mA	Output load current: 4mA	V_{OL3}			0.2* V_{DD}
Logic0 output voltage, 20mA	Output load current: 4mA	V_{OL20}			0.2* V_{DD}
Logic1 output voltage, 3mA	Output load current: 20mA	V_{OH3}	0.8* V_{DD}		
Logic1 output voltage, 20mA	Output load current: 20mA	V_{OH20}	0.8* V_{DD}		

Table 7-1 Digital IO Specification of SZU06A2

8 AC Electrical Characteristics

$V_{DD}=3.3V, T_{OP}=25^{\circ}C$.

No	Parameter	Test conditions	Min	Typ.	Max	Unit
1	Frequency range		2400		2500	MHz
2	Channel number	See Table 10.2 for the correspondence between channel and frequency	CH11		CH26	
3	Input impedance		47	50	53	Ω
4	Receiver sensitivity	PER=1%	-100	-98	-97	dBm
5	Input level Input voltage	PER=1%			10	dB
6	High-side adjacent channel rejection, 1% PER. Desired is reference signal at 3dB above reference sensitivity level ^①	Interferer is reference signal at +1 channel-spacing.	-	33.75	-	dB
		Interferer is filtered reference signal ^② at +1 channel-spacing.	-	52.5	-	dB
7	Low-side adjacent channel rejection, 1% PER. Desired is reference signal at 3dB above reference sensitivity level ^①	Interferer is reference signal at -1 channel-spacing.	-	35	-	dB
		Interferer is filtered reference signal ^② at -1 channel-spacing.	-	54.7	-	dB
8	Alternate channel rejection, 1% PER. Desired is reference signal at 3dB above reference sensitivity level ^①	Interferer is reference signal at ± 2 channel-spacing.	-	45.9	-	dB
		Interferer is filtered reference signal ^② at ± 2 channel-spacing.	-	56.8	-	dB
9	Co-channel interferer rejection, 1% PER	Desired signal 10 dB above sensitivity limit	-	-2.6	-	dB
10	RSSI Resolution		-	0.25	-	dB

11	RSSI accuracy in the linear region as defined by 802.15.4-2003		-	±1	-	dB
12	Frequency Tolerance for the crystal	38.4 MHz, ESR = 50 Ω , CL = 10pF	-40		+40	ppm
13	Occupied channel bandwidth per ETSI EN300.328	99% BW at highest and lowest channels in band	-	2.25	-	MHz
14	Error vector magnitude(EVM)	Output power at lowest power setting:8dBm	-	5.5%	-	%rms
15	Actual maximum output power	Output power at lowest power setting:8dBm		8	8.5	dBm
16	Actual minimum output power	Output power at lowest power setting:-26dBm	-28	-27	-26	dBm

Table 8-1 RF Characteristics of SZU06A2 RF Transceiver

Notes:

①Reference sensitivity level is -85 dBm.

②Filter is characterized as a symmetric band-pass centered on the adjacent channel having a 3dB bandwidth of 4.6 MHz and stop-band rejection better than 26 dB beyond 3.15 MHz from the adjacent carrier.

Channel	Frequency(center)	Channel	Frequency (center)
CH11	2,405MHz	CH19	2,445MHz
CH12	2,410MHz	CH20	2,450MHz
CH13	2,415MHz	CH21	2,455MHz
CH14	2,420MHz	CH22	2,460MHz
CH15	2,425MHz	CH23	2,465MHz
CH16	2,430MHz	CH24	2,470MHz
CH17	2,435MHz	CH25	2,475MHz
CH18	2,440MHz	CH26	2,480MHz

Totally 16 channels, frequency coverage: 2400MHz--2483MHz

Table 8-2 Channel VS. Frequency of SZU06A2

9 Physical Dimensions and Footprint

9.1 Physical Dimensions

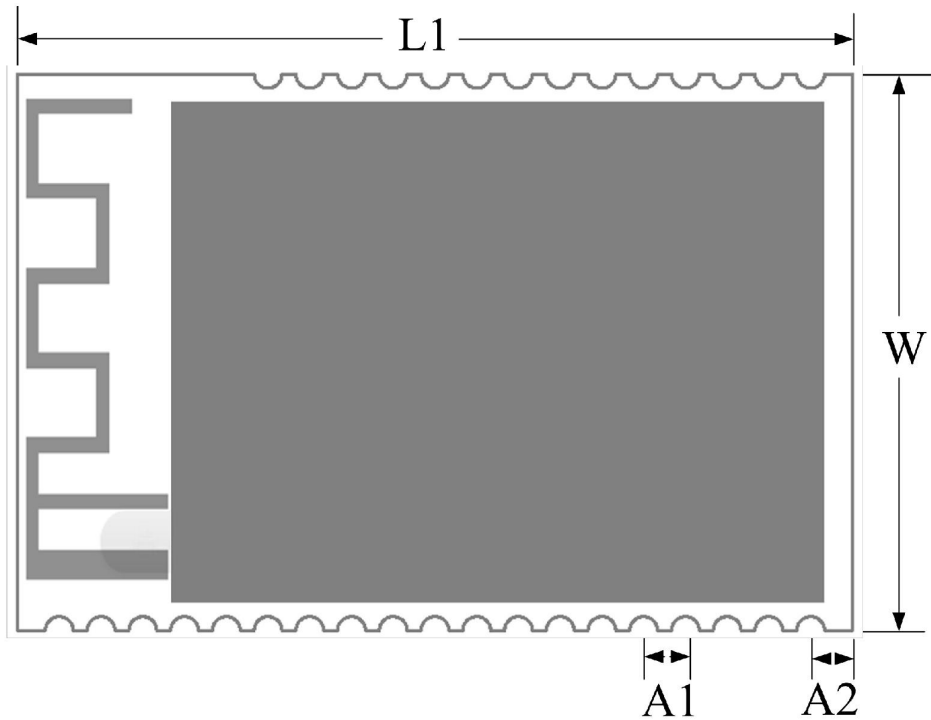

Fig. 9-1 Physical Dimensions of SZU06A2

Parameter	Parameter Description	Parameter value
W	Module width	19mm
L1	Module length	25mm
A1	Distance between semi-holes	1.27mm
A2	Distance from semi-hole to PCB	0.8mm

Table 9-1 Physical Dimensions of SZU06A2

9.2 Recommended Footprint

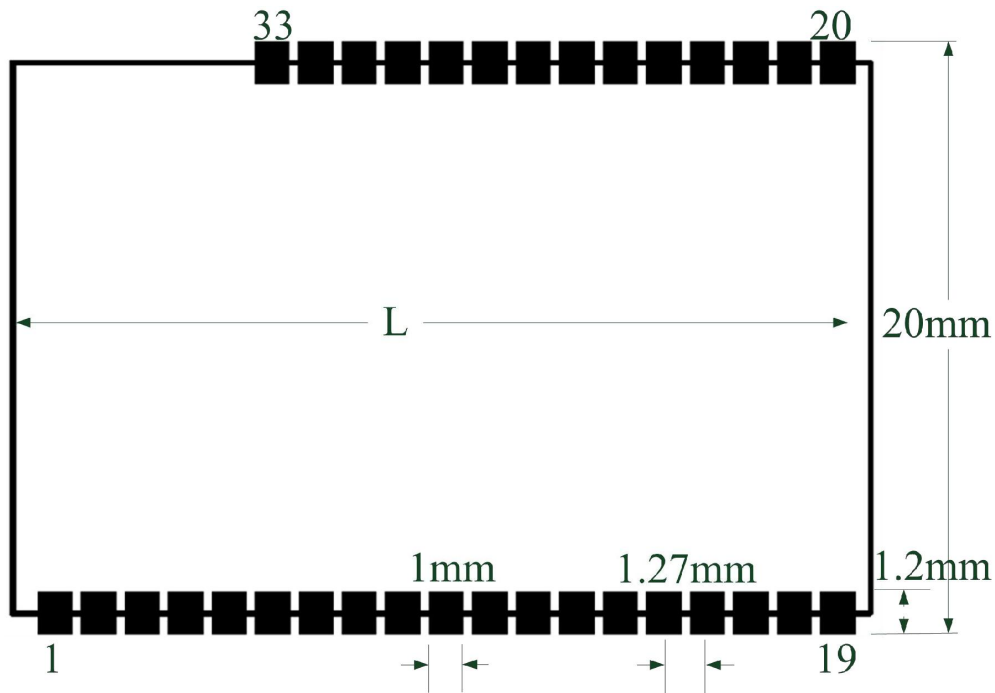

Fig. 9-2 Recommended Footprint of SZU06A2

Notes:

1. When the surface mounted SZU06A2 ZigBee wireless communication module is used, it is suggested that the bonding pad shall be 1mm wide and 1.2mm high.
2. $L=25\text{mm}$.
3. You must ensure that the corresponding PCB of “keep-out area” part in Fig. 3-1 shall have no any device, running line or applied copper.
4. You must also ensure that there is no exposed copper on your layout which may contact with the underside of the module.
5. To get the best RF performance, it is recommended that each GND pin shall be connected to a complete ground level.
6. It is recommended to use multiple vias between each ground pad and a solid ground plane to minimize inductivity in the ground path.

10 Soldering Temperature Time Profile (for reflow soldering)

10.1 Recommended temperature time profile for lead-free solder

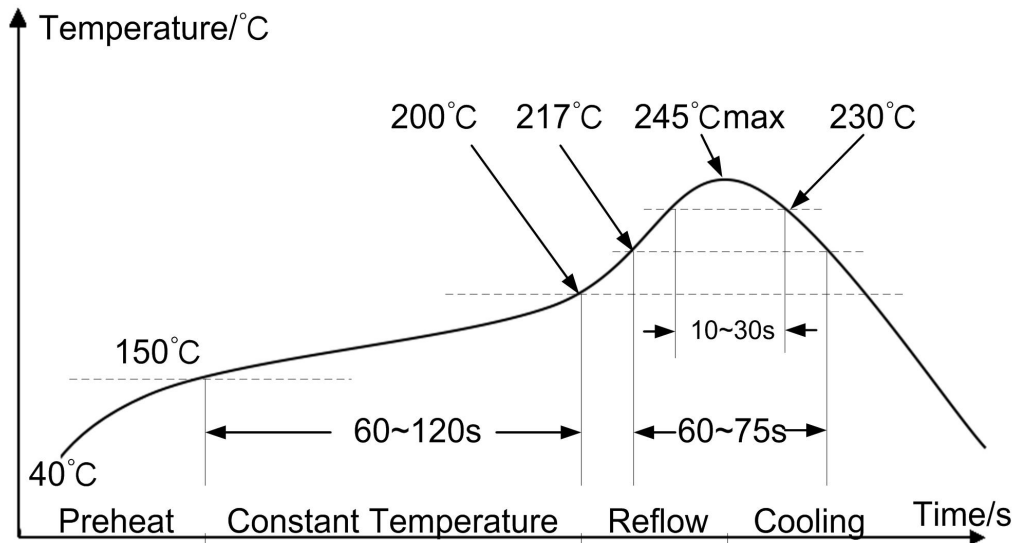

Fig. 10-1 SZU06A2 Temperature Profile for Lead-free Solder

Notes:

Preheat: The recommended temperature climbing speed shall be 2°C/s and not exceed 2.5°C/s at the preheat area.

Cooling: The recommended temperature descent speed shall be 3°C/s and not exceed 4°C/s at the cooling area.

Maximum Reflow Cycles of the module: twice



The module must not be placed at the bottom of PCB board for reflow soldering (if the module is placed at the bottom of PCB board for reflow soldering, device inside the module will drop off due to gravity).

11 Reliability Test

To guarantee the environment adaptability of SZU06A2, we have done the the following measurements.

No	Test items	Test methods
1	Vibration test	Setting the vibration frequency of 50Hz, amplitude of 1.5mm, and each side of XYZ vibrates for 20 minutes respectively
2	Shock test	The module is dropped from the height of 50cm to hard floor to carry out the test for 3 times
3	Heat cycle test	Charged operation of module: start temperature of cycle: 25°C-->-40°C (30 minutes) -->85°C (30 minutes), for 5 cycles between high and low temperature
4	Moisture test	Module operates at the environment of + 60°C and 90% RH for 24 hours
5	Low temperature cold start test	Module will be powered after placed in the environment of -40°C for 1 hour
6	Low temperature test	Operating in the environment of -40°C for 3 * 24 hours
7	High temperature test	Operating in the environment of +85°C for 3 * 24 hours

Table 11-1 Reliability Test of SZU06A2

12 Application Precautions

12.1 Safety precautions

Before use of SZU06A2, check and evaluate their operation when mounted on your products . These products may short-circuit. If electrical shocks, smoke, fire, and/or accidents involving human life are anticipated when a short circuit occurs, then provide the following failsafe functions as a minimum :

- (1) One protective circuit shall be designed or the protective device shall be installed to ensure the system safety
- (2) One redundant circuit or one system shall be designed to prevent the safety loopholes due to single malfunction so as to ensure the system safety.

12.2 Engineering design and using precautions

(1) Excess temperature during use of the products is the major factor of shortening the life of the products. Thus, full consideration of the impacts of heat radiation shall be taken in the design or use of the products to ensure that the environment temperature of the products shall not exceed the maximum operable temperature.

(2) Otherwise, it may cause the reduction of the product performance and damage the products.

(3) If impulse or other transient load will be loaded to your products, the operation of SZU06A2 module must be inspected before installation and the potential impacts on the products shall be evaluated.

(4) When the products are used under the following special environment, the product manual shall be carefully read and the using of performance and reliability of SZU06A2 must be evaluated;

- Liquid environment. Such as water, saline water, paint, alkali, organic solvent or other possible sprinkle liquid

- The environment of direct sunshine, outdoor or dusty environment
 - Environment easy to condensation
 - Environment with high concentration and harmful gases (such as air with salt, muriatic acid, chlorine, sulfur dioxide, sulfuretted hydrogen, ammonia gas or nitrogen oxide)
- (5) Mechanical stress shall be avoided in assembly or operation of SZU06A2.
- (6) Do not press the shielding cover or tighten the objects to the shielding cover
- (7) When the SZU06A2 is working, the safe distance between it and human body must be greater than 20 centimeters.

12.3 Storage conditions

- (1) SZU06A2 must not be stressed mechanically during storage
- (2) Performance characteristics of the module shall not be evaluated under the following environment and the storage under this environment may have a large impact on the performance of SZU06A2 (such as RF performance).
- ✧ Salty air or environment with high concentration corrosive gases (such as Cl₂, H₂S, NH₃, SO₂, OR NO_x)
 - ✧ Storage in direct sunshine
 - ✧ Storage in an environment where air humidity exceeds 85%
- (3) After the above-mentioned conditions are satisfied, the storage time of the module during assembly of final products shall not exceed two years.

13 Packaging

13.1 Carrier tape

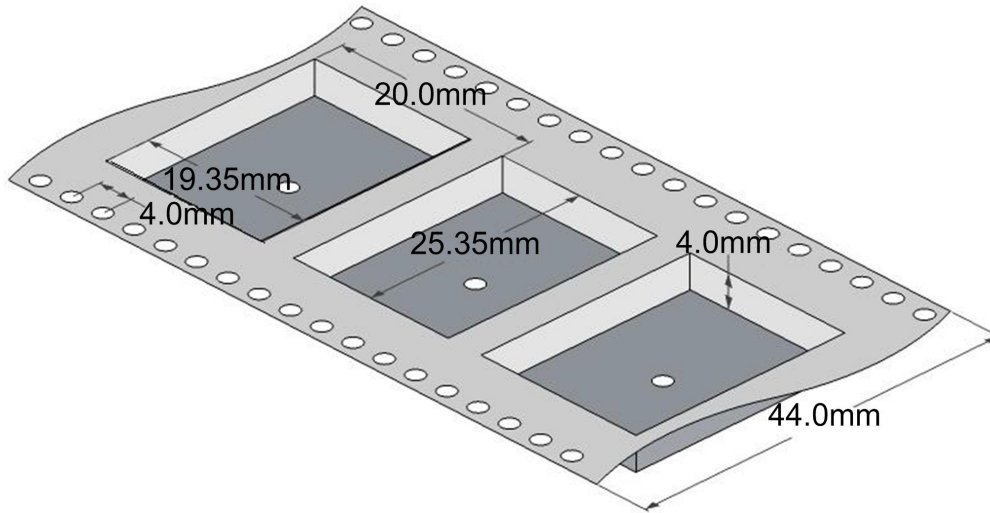

Fig. 13-1 Dimension of Carrier Tape (Top View)

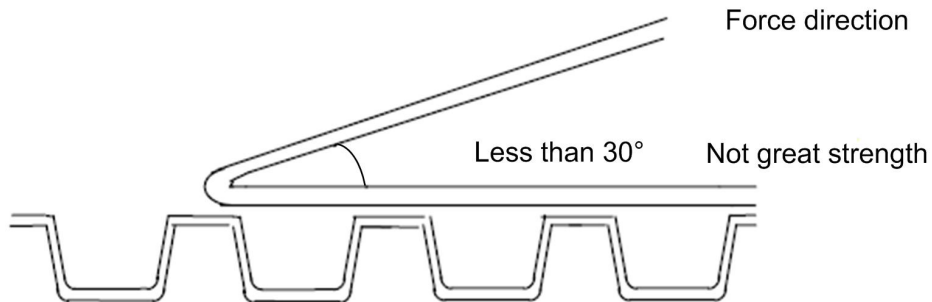

Fig. 13-2 Diagram of Cover Tape

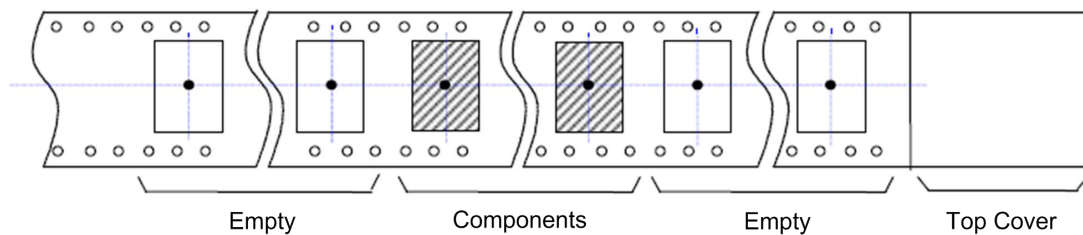

Fig. 13-3 Diagram of Empty pocket

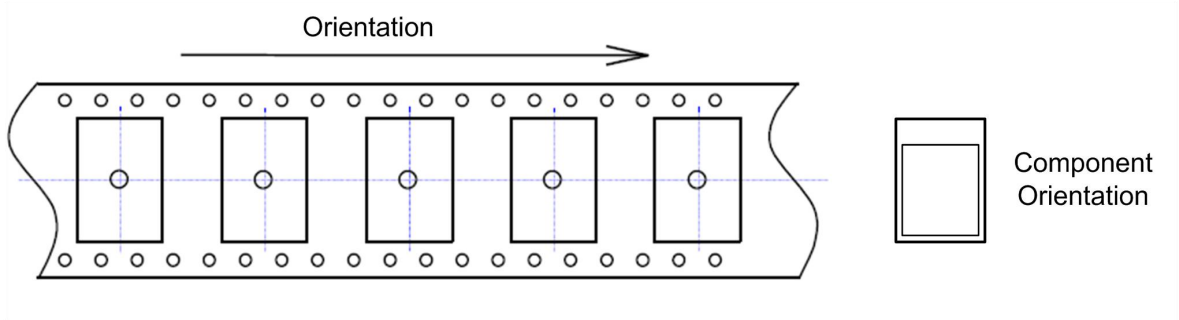

Fig. 13-4 Orientation of SZU06A2

13.2 Reel

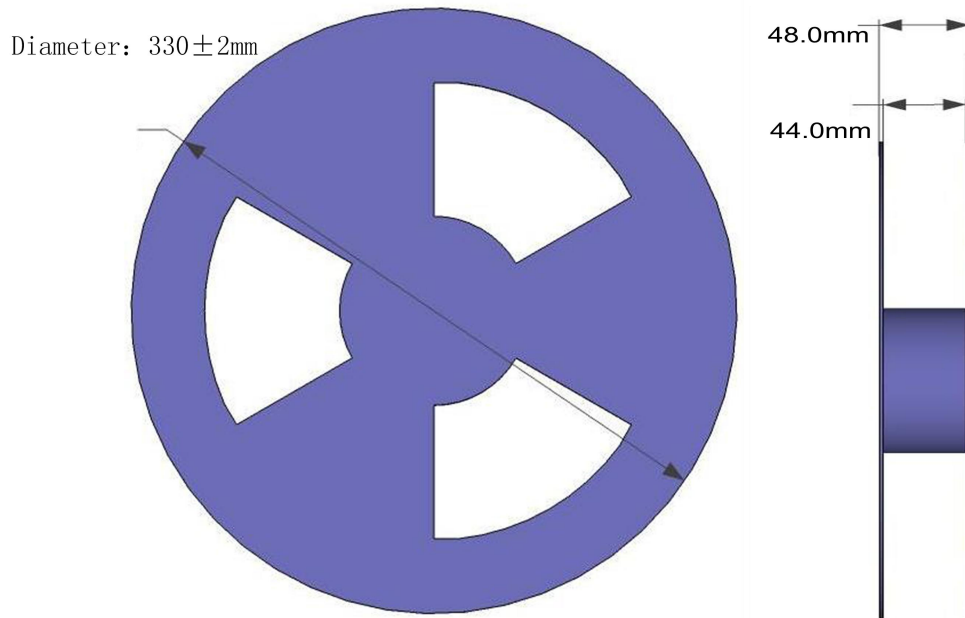
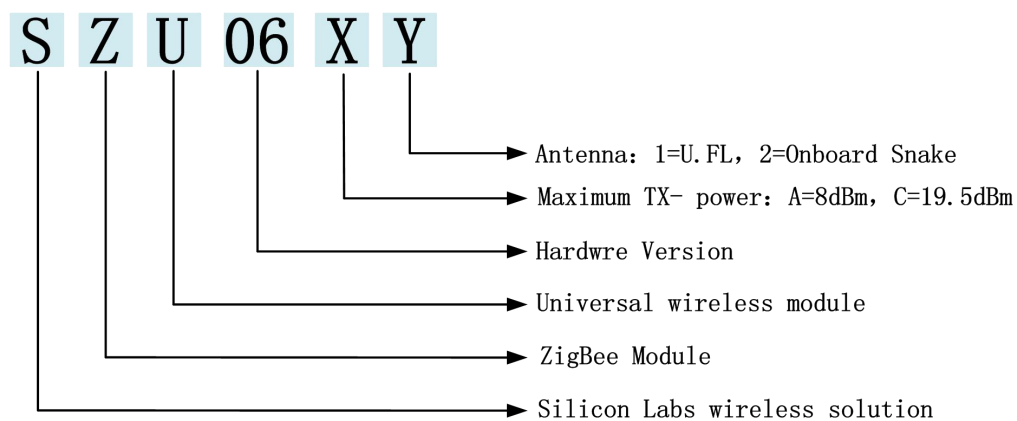

Fig. 13-5 Reel Dimensions

Each reel will be packed in a electrostatic shielding bag

14 Ordering Information

Product code	Brief description
SZU06A2	<ul style="list-style-type: none"> ● Based on EFR32MG1single chip solution ● On-board snake antenna ● 19mm * 25mm * 3.7mm ● Visible barrier-free communication distance is 600m @-69dBm
SZU06DVK	<p>Development kit contains</p> <ul style="list-style-type: none"> ● 2 X SZURF-EVB Development Boards ● 2 X SZU06A1 on Carrier-Board ● 2 X SZU06A2 on Carrier-Board ● 2 X SZU06C1 on Carrier-Board ● 2 X SZU06C2 on Carrier-Board
Development Kit	<ul style="list-style-type: none"> ● 2 X Pulse 2.0dbi antenna ● 2 X RF feeder ● 2 X molex Micro-USB-to-USB-A data cable ● DIYUE Terminal and user manual ● SZU06 Development Kit User Manual ● SZU06 series module firmware



15 Drawing of Product Label



Fig. 15-1 SZU06A2 Product Label

The label dimensions are 15.2mm*17mm and the label will withstand temperatures used during reflow soldering.

Mark	Detailed Description
SZU06A2	Module model
CE	CE mark
2D-Barcode	2D-Barcode shall include four parts: product batch, hardware reversion, module model and product serial number
FCC ID	FCC ID mark and number
170612	1706:Product batch;32:product code
753159963258	Product serial number
 II 3G Ex ic IIC Gc	Ex mark
TPS 17 ATEX 93558 006 U	ATEX Certificate number

Table 15-1 SZU06A2 Label details

16 Disclaimer

We reserve the right to modify or improve the product, company name and LOGO at any time without prior notice. In addition, Chengdu Diyue Technology Co., Ltd. does not convey any license under its patent rights or assume any responsibility for the use of the described product.

17 RoHS Declaration

Statement of compliance of SZU06A2 ZigBee wireless communication module to EU environmental protection:

Hereby we declare to our best present knowledge based on the declaration of our suppliers that SZU06A2 does not contain the following substances which are banned by Directive 2011/65/EU (RoHS) or if they do, contain a maximum concentration of 0,1% by weight in homogeneous materials for:

- ✧ Lead and lead compounds
- ✧ Mercury and mercury compounds
- ✧ Hexavalent Chromium
- ✧ PBB (polybrominated biphenyl) category
- ✧ PBDE (polybrominated biphenyl ether) category

And a maximum concentration of 0.01% by weight in homogeneous materials for:

- ✧ Cadmium and cadmium compounds

18 Data Sheet Status

In order to improve design performance and supply the best possible products to customers, Chengdu Diyue Technology Co., Ltd. reserves the right to change the product specifications without notice. Please download the latest product specifications provided by our company before initiating or completing one design.

19 Reference Documents

[1] Data sheet CC2530.TI. (www.ti.com-CC2530)

[2] Data sheet CC2591.TI. (www.ti.com-CC2591)

[3] Z-Stack-CC2530-2.5.1a (www.ti.com-Z-Stack-CC2530-2.5.1a)

20 Contact Information

Website: www.cdiyue.com

Add.: 4/F, Block A, Gaofa Building, No.6, Jiuxing Avenue, High-tech Zone, Chengdu

Tel: 0086-28-85138368

Fax: 0086-28-85189190

E-mail : public@cdiyue.com

Sales In China

Tel: 0086-28-85106132

Fax: 0086-28-85189190

E-mail : sales@cdiyue.com

International sales

Tel: 0086-28-85327536

Fax: 0086-28-85189190

E-mail : wsales@cdiyue.com