

CHERRY 

Energy harvesting wireless switch

Evaluation kit
Comfort/Engineer

Operating manual

Safety guidelines



WARNING: Danger to life

- Do not install this kit as part of a safety-relevant, life or health preserving facility.



CAUTION: Damage to components of the evaluation kit due to electrical discharge

- Observe the ESD protection.



CAUTION: Damage due to liquid in the components of the evaluation kit

- Prevent liquid from getting inside the components.
- Do not use solvents such as benzine or alcohol, or scouring agent and scourers for cleaning.

Contents

1	Area of application	4
1.1	Comfort evaluation kit.....	5
1.2	Engineer evaluation kit	6
2	Product description	7
2.1	Wireless switch	7
2.2	Generator model	7
2.3	Receiver	8
2.4	Software.....	8
2.5	Antennas.....	9
2.6	CD.....	9
3	Installing the USB driver	10
4	Installing software	11
5	Troubleshooting.....	13
6	Technical data.....	14
7	Engineer receiver interfaces.....	16
8	Declaration of conformity.....	19
9	Disposal.....	19
10	Contact	19
11	General user information	20

1 Area of application

The evaluation kits were designed to show you the main function and output of the energy harvesting wireless switch.

The components provided are for testing purposes and not suitable for using in a serial product, continuous operation or permanent connection to other units.

1.1 Comfort evaluation kit

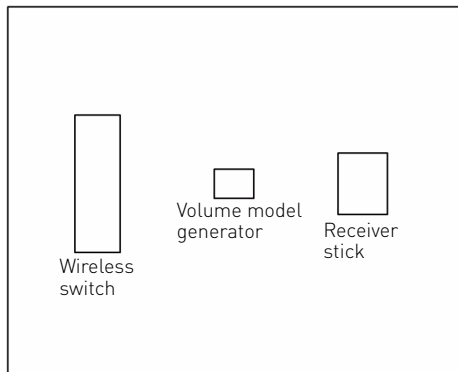

The Comfort evaluation kit receiver class 3 was developed for convenient operation in a compact design.

As only a small antenna is fitted due to its compact design, the range is less than with an external antenna.

The switch signals are displayed on the receiver stick with LEDs. You can also see the strength of the signals via software on a computer.

1.2 Engineer evaluation kit

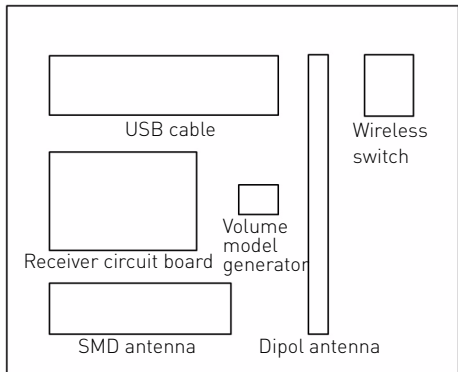

The engineer evaluation kit receiver class 2 is designed for optimum output and consists of several interfaces for the development environment. It may only be operated by those with electrical engineering expertise.

To gain direct access to the interfaces, the receiver consists of a large circuit board without housing. Several antennas can be connected to the SMA

connection on the circuit board.

See also: 7 "Engineer receiver interfaces".

You can also see the strength of the signals via the software on a computer. These can be exported for measuring.

2 Product description

2.1 Wireless switch

The switch contains a generator which converts the mechanical energy of the probe into electrical energy. The energy supplies the wireless electronics and data is transmitted the with 868 MHz (Europe) or 915 MHz (US version).

2.2 Generator model

To show the small size of this part, the evaluation kit contains a functionless volume model of the generator.

2.3 Receiver

The radio signal is received by the antenna. The electronics interpret the data and transmit the information to the hardware and software interfaces. The information is displayed via LEDs and the software.

See also: 7 "Engineer receiver interfaces".

2.4 Software

The software on the computer displays the following data:

Name	Value
Time stamp	Incoming time of the signal
UID	Switch ID
State	Switch status
Message	Signal received
Count	Number of signals received
Signal strength	Signal strengths received in dBm and nW/pW

You can save up to 10 000 data sets. The data can be deleted using the "Clear" button and saved as *.txt files using the "Export" button. The

communication with individual switches and the relay function can be deactivated.

2.5 Antennas

The Engineer evaluation kit contains 2 exchangeable antennas:

- SMD antenna circuit board with SMA connector
- SMA dipole antenna

2.6 CD

The CD contains demonstration software, CAD files with the dimensions and these operating instructions.

3 Installing the USB driver

System requirements:

Windows XP, Vista or 7, USB 2.0 connection.

1 Copy the "Cherry_EHS-RF_Software" folder from the CD onto your computer.

2 Connect the receiver.

- **Comfort evaluation kit:**

Plug the receiver stick into the computer so that the components (LEDs) can be seen on the circuit board. Use a USB hub or an extension cable if necessary.

- **Engineer evaluation kit:**

Connect the receiver circuit board to the computer using the USB cable provided.

The yellow LED flashes on the receiver.

The device driver installation prompts you to install the driver software. The drivers for 32- and 64-bit variants are located in the "Cherry_EHS-RF_Software/Driver" folder.

3 Follow the instructions in the installation wizard. If problems arise, you will find detailed video instructions on the CD.

The yellow LED lights up on the receiver.

- 4 Press and hold down the button on the wireless switch.
The green LED lights up.
- 5 Release the button again on the wireless switch.
The blue LED lights up.

4 Installing software

Requirement: The receiver is connected and the USB driver is installed (see 3 "Installing the USB driver"). The "Cherry_EHS-RF_Software" folder is on your computer.

- 1 Link the "RadioMonitor.exe" file on your desktop for later access.
- 2 Start the link to "RadioMonitor.exe".
If "dotNET Framework V4" is not installed on your computer you will receive a message. Load "dotNET Framework V4" from the CD and install it.
The "Set_Check_COM" window appears.
- 3 Select the COM port of the receiver from the list. (This is usually the one with the highest number.)

4 Press the wireless switch.

When you have selected the COM port of the receiver, the switch position is shown on the switch diagram.

The "Next >" button is active.

- **If the button is not active:**

Repeat the procedure by selecting another COM port from the list until you have found the connection for the receiver.

5 Click on the **Next >** button.

The "RadioMonitor" window appears.

6 Press the switch.

The status of the switch is displayed by the switch diagram, the two round areas and the status display in the table. (Green = Status 0 = pressed. Blue = Status 1 = released.)

5 Troubleshooting

- **The yellow LED on the receiver is not flashing:**
 - Use another USB port on the computer/laptop.
- **The reception is poor:**
 - Remove any metal objects from the transmission area.
 - Do not place transmitters and receivers directly on reflecting objects or walls.
 - Switch off any possible sources of radio interference, such as electrical appliances or machines.
 - Adjust the position of the antenna.
 - Shorten the distance between transmitter and receiver.
 - Do not keep pressing the switch in quick succession.
- **The same switching status is received several times in a row (00 or 11):**
 - Do not keep pressing the switch in quick succession.

6 Technical data

Name	Value
Storage and operating temperature	0 °C ... +50 °C
Permissible relative humidity	10 ... 90 %, noncondensing
Supply voltage receiver	5.0 V/DC \pm 5 % SELV
Receiver current consumption	Max. 100 mA
Receiver connection	USB 2.0, max. 3 m cable to computer
Frequency	EU (AFIK-1xxx): 868 MHz US (AFIK5xxx): 915 MHz
Modulation	FM
Transmission range	Open field: typ. 300 m, in buildings: typ. 30 m
Transmitter power level	At antenna connection: 10 dBm, on the antenna: max 9 dBm

Name	Value
Damping receiver	SMD circuit board antenna: typ. 5 dB SMA dipole antenna: typ. 1 dB
Receiver signal-to-noise ratio	Min. 6 dB
Analog interfaces	0 ... 5 V (USB input voltage), 10 bit resolution, max. output current 5 mA, short-circuit protected
Digital interfaces	5 V TTL, max. continuous current 5 mA, short-circuit protected

7 Engineer receiver interfaces

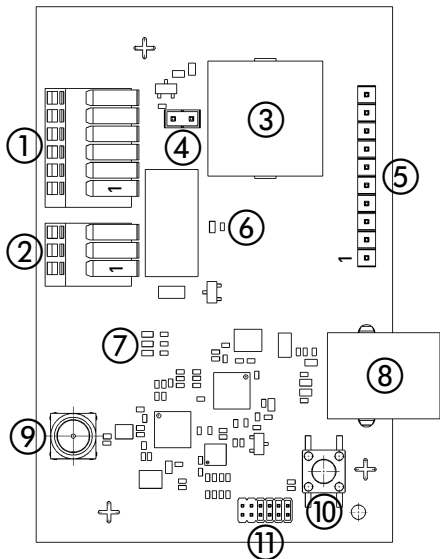

No.	Item	Description*
①	1	Analog 1: dimming
	2	Analog 4: signal strength dBm
	3	Digital 1: switch position
	4	Digital 2: weak signal
	5	Digital 3: interrupt for valid data
	6	COM 1: interrupt for invalid data
②		Relay, 12 V/DC, 1 A
	1	A
	2	COM
③		B
		Buzzer, 4 kHz
		Jumper set: buzzer on
⑤	1	Analog 2: dimming inverted
	2	Analog 3: reserved
	3	LED: LED status

No.	Item	Description*
	4	Digital 4: dimmer pulse width modulation (PWM)
	5	Digital 5: reserved
	6	Digital 6: reserved
	7	COM 2: interrupt for valid data (RF)
	8	Supply voltage (V_{CC})
	9	Earth (GND)
	10	Digital 7: ATA
	⑥	LED red
	⑦	Status LEDs: blue, yellow, green
	⑧	USB port
	⑨	Antenna connection SMA
	⑩	Reset button
	⑪	Internal programming interface for CHERRY

* You will find detailed comments on the CD.

8 Declaration of conformity



These components are CE certified and comply with the EN 300-220 guidelines. They were made and tested for use in Europe and USA in accordance with the FCC Part 15.249 and 15B. Observe the local regulations before using in other countries.

9 Disposal



Dispose of the used components of the evaluation kit at an official collection point for electronic waste or at your local dealer.

10 Contact

ZF Friedrichshafen AG
Electronic Systems
Cherrystraße
91275 Auerbach, Germany

Internet: www.cherryswitches.com

E-mail: info@cherryswitches.com

11 General user information

We reserve the right to make technical modifications which serve the development of our products. Improper use and storage can lead to faults and damage to the product.

The warranty expires completely once unauthorized modifications to the product have been carried out. Do not carry out any unauthorized repairs and do not open up the product. These instructions are only valid for the supplied product.

The warranty for this product is for commercial customers for one year from date of purchase. Liability for financial damages and defects is excluded.