

JD-0100

# PURE



WIRELESS MULTIMEDIA DESKTOP









Bedienungsanleitung  
Operating Manual  
Mode d'emploi  
Guida rapida  
Introducción  
Verkorte gebruikshandleiding

**CHERRY** 

## Tastenbelegung / Button function / Programmation des touches / Asignación de teclas / Assegnazione dei tasti / Toetstoewijzing

<p>Batteriestatus-LED Battery status LED DEL indiquant l'état des piles Visualización LED del estado de las pilas LED di indicazione dello stato delle batterie LED voor weergave van batterijstatus</p>	<p>Medioplayer Medioplayer Medioplayer Reproducteur multimedia Media Player Mediaspeler</p>	<p> </p>	<p>Browser, Startseite Browser, home Navigateur, démarrage Navegador, página de inicio Browser, home page Browser, startpagina</p>
	<p>E-Mail Programm E-Mail program Programme E-Mail Programa de correo electrónico Programma e-mail E-mailprogramma</p>	<p></p>	<p>Standby Standby Mise en veille Suspend Standby Stand-by</p>



<p>Ton leiser Volume down Volume plus bas Bajar volumen Diminuzione volume Geluid zachter</p>	<p></p>	<p></p>	<p>Nächster Titel Next title Titre suivant Título siguiente Titolo successivo Volgende titel</p>
<p>Ton an/aus Sound on/off Activer/désactiver le son Activar/desactivar el sonido Attivazione/disattivazione dell'audio Geluid in-/uitschakelen</p>	<p></p>	<p></p>	<p>Start/Pause Play/pause Lecteur/pause Inicio/Pausa Start/Pausa Start/Pauze</p>
<p>Ton lauter Volume up Volume plus fort Subir volumen Aumento volume Geluid harder</p>	<p></p>	<p></p>	<p>Voriger Titel Previous title Titre précédent Título anterior Titolo precedente Vorige titel</p>

Batteriestatus-LED  
Battery status LED  
DEL indiquant l'état de la pile  
Visualización LED del estado de  
la pila  
LED di indicazione dello stato della  
batteria  
LED voor weergave van  
batterijstatus

Browser vor  
Browser forward  
Navigation avant  
Navegador adelante  
Browser avanti  
Browser, vooruit

Browser zurück  
Browser back  
Navigation arrière  
Navegador atrás  
Browser indietro  
Browser, achteruit

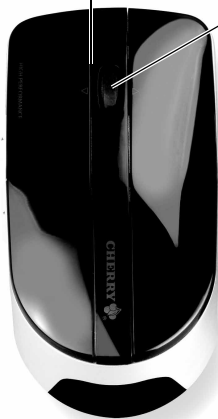

Durch seitlichen Druck auf das  
Scroll-Rad:  
Horizontal scrollen (links/rechts)

Side press on the scroll wheel:  
horizontal scroll (left/right)

Pression latérale sur le bouton de  
roulette:  
défilement horizontal  
(gauche/droite)

Desplazar horizontalmente  
(a izquierda/derecha) al presionar  
lateral en la rueda de  
desplazamiento

Premendo lateralmente sulla  
rotellina per lo scrolling:  
scorrimento orizzontale (sinistra/  
destra)

Door te drukken aan de zijkant van  
het scrollwiel:  
horizontaal scrollen (links/rechts)

- 1 Empfänger anschließen / Connecting receiver / Raccorder le récepteur / Conectar receptor / Collegare il ricevitore / Ontvanger aansluiten

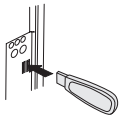

- 2 Batterie in die Maus einlegen / Inserting battery into the mouse / Insérer la pile dans la souris / Introducir la pila en el ratón / Inserire la batteria nel mouse / Batterij in de muis plaatsen

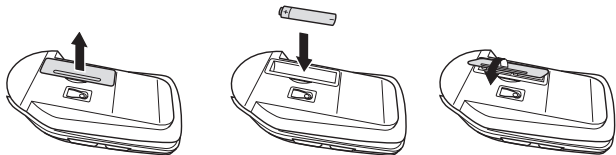

- 3 Batterien in die Tastatur einlegen / Inserting batteries into the keyboard / Insérer les piles dans le clavier / Colocar pilas en el teclado / Inserire le batterie nella tastiera / Batterijen in het toetsenbord plaatsen

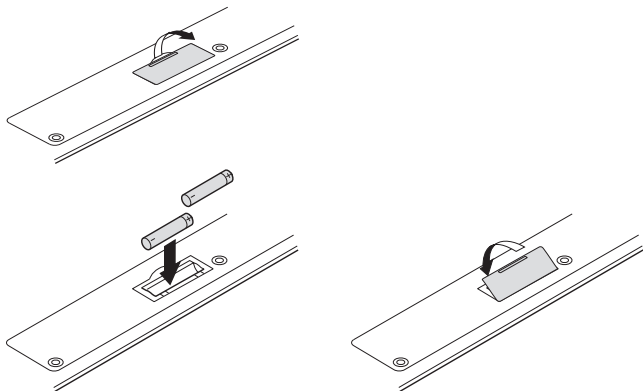

# Operating Manual

## Congratulations!

When you select a quality product from Cherry, you've always made the right choice. Cherry is a registered brand of ZF Electronics GmbH.

The following features in particular set your **PURE** apart:

- The freedom of no cables with a range of 10 m
- Precise and fast with optical sensor
- The red LED indicates that the batteries need to be replaced in good time
- Horizontal scrolling through side pressure on the scroll wheel. In order to use this function, software must be installed. (Download free-of-charge at: [www.cherry.de/english/service/download.php](http://www.cherry.de/english/service/download.php))

For information on additional products, downloads, and much more, please visit [www.cherry.de](http://www.cherry.de) or [www.cherrycorp.com](http://www.cherrycorp.com)

We hope you enjoy your new **PURE**.  
Your Cherry Team

## 1 Tips

### 1.1 Surface under the mouse

A bright, structured surface under the mouse increases the efficiency of the mouse and ensures optimum detection of movement.

A reflective surface is not suitable for use under the mouse.

### 1.2 Cleaning the devices



#### Caution!

Damage may be caused by harsh cleaning agents or liquids in the devices

- 1 Do not use solvents such as gasoline or alcohol and scouring agents or scouring sponges for cleaning.
  - 2 Prevent liquids from entering the devices.
  - 3 Do not remove the keycaps of the keyboard.
- 
- 1 Clean the mouse with a slightly damp cloth and some mild cleaning agent (e.g. dishwashing liquid).
  - 2 Dry off the mouse with a soft, lint-free cloth.

### 1.3 Disposal



Dispose of the old unit and the batteries via a collecting point for electronic scrap or via your dealer.

## 1.4 RSI syndrome



### RSI syndrome

RSI stands for "Repetitive Strain Injury". RSI results from small, continually repeated movements.

Typical symptoms are discomfort in the fingers or neck. For further information see: [www.cherry.de/english/service/servicedownload\\_rsi.htm](http://www.cherry.de/english/service/servicedownload_rsi.htm)

- 1 Set up your workspace for maximum ergonomic benefit.
- 2 Position the keyboard and mouse in such a way that your upper arms and wrists are on either side of your body and are stretched out.
- 3 Take several short breaks, with stretching exercises if necessary.
- 4 Change the position of your body often.

## 2 Troubleshooting

- 1 Check whether the batteries are inserted correctly and supply sufficient voltage.
- 2 Connect the receiver to another USB port on the PC.

## 3 Technical data

Designation	Value
Supply voltage keyboard	2.2 ... 3.0 V SELV
Supply voltage mouse	0.75 ... 1.5 V SELV
Supply voltage receiver	5.0 V/DC $\pm 5\%$ SELV
Current consumption keyboard	max. 3 mA
Current consumption mouse	max. 25 mA
Current consumption receiver	max. 30 mA
Battery type keyboard	2 batteries, type AAA (LR03)
Battery type mouse	1 battery, type AA (LR6)
Storage temperature	-20 °C ... +60 °C
Operating temperature	0 °C ... +40 °C

## 4 Contact

ZF Electronics GmbH  
Cherrystraße  
91275 Auerbach, Germany  
www.cherrycorp.com  
www.cherry.de  
E-mail: info@cherry.de  
Telephone:

Sales: +49 (0) 180 5 243779\* (0180 5 CHERRY\*)

Technical support: +49 (0) 180 5 919108\*

(\*14 euro cent/min. from German landlines, prices may vary for calls made from mobile networks.)

Please have the following information on hand when contacting technical support:

- Item and serial no. of the product
- Name and manufacturer of your system
- Operating system and, if applicable, installed service pack version

## 5 General advice

Cherry, a brand of ZF Electronics GmbH, continuously optimizes its products as new technologies are developed. For this reason we reserve the right to make technical alterations. The evaluation of product reliability and the definition of the product's technical performance are carried out according to our own requirements in order to meet internationally recognized regulations and standards. Requirements in addition to these can be met through mutual cooperation. Improper usage, handling, storage and external influences could lead to faults and defects during use.

We do not accept warranty for defects caused by alterations to our product by the user and shall not be held liable for unauthorized modifications. All repairs must be made by us or an officially appointed organization or person.

Possible compensation claims against ZF Electronics GmbH or its nominated officers – whatever the legal justification including physical or stress related injuries – are excluded. Exceptions to this exist in the case of intent or gross negligence on the part of ZF Electronics GmbH, infringements of Product Liability Law or in cases of injury, bodily harm or risk to health. These operating instructions only apply to the accompanying product. Full details can be obtained from your distributor or direct from us.

## 6 Warning note



### Danger of suffocation due to swallowing of small parts

- Ensure that this unit does not end up in the hands of children under the age of six.

## 7 Certifications

### 7.1 CE Declaration of Conformity

Hereby, ZF Electronics GmbH, Auerbach/Opf., Germany, declares that this Radio-Frequency peripheral is in compliance with the essential requirements and other relevant provisions of Directive 1999/5/EC. The CE Declaration of Conformity can be retrieved by accessing the following internet address:

**www.cherry.de/compliance**

Once accessed, click on the relevant product name to retrieve the CE Declaration of Conformity.

### 7.2 Federal Communications Commission (FCC) Radio Frequency Interface Statement

Information to the user: This equipment has been tested and found to comply with the limits for Class B digital device, pursuant to Part 15 of the FCC Rules. These limits are designed to provide reasonable protection against harmful interference in a residential installation. This equipment generates, uses and can radiate radio frequency energy and, if not installed and used in accordance with the instructions, may cause harmful interference to radio communications. However, there is no guarantee that interference will not occur in a particular installation. If this equipment does cause harmful interference to radio or television reception, which can be determined by turning the equipment off and on, the user is encouraged to try to correct the interference by one or more of the following measures:

- Reorientate or relocate the receiving antenna.
- Increase the separation between the equipment and receiver.
- Connect the equipment into an outlet on a circuit different from that to which the receiver is connected.
- Consult the dealer or an experienced radio/TV technician for help.

Caution: Any changes or modifications not expressly approved by the party responsible for compliance could void the user's authority to operate the equipment.

### 7.3 For UL

For use with Listed Personal Computers only!

# Restricted Manufacturer's Guarantee

**Restricted Guarantee – statutory Guarantee:** Please note that the Restricted Manufacturer's Guarantee set out below applies in addition to your statutory guarantee and neither replaces nor restricts it. Please contact the seller of this product with any claim based on your statutory guarantee rights arising from the sale of consumer goods.

**Guarantee rights:** Cherry is a registered brand of ZF Electronics GmbH. With effect from June 1, 2006, ZF Electronics GmbH ("ZF Electronics") grants the purchaser of this Cherry product ("Product") a Restricted Manufacturer's Guarantee ("Guarantee") provided that this Product is bought and used by the purchaser in his capacity as a consumer. Commercial users of this Product or purchasers acting in their capacity as entrepreneurs are excluded from the Guarantee as set out below. The granting of a guarantee and its contents for these purchasers can be agreed with ZF Electronics individually at the contact address given in the instructions for use.

The Guarantee is not transferable and is limited to the original purchaser.

This Guarantee applies only to Products bought in a member state of the European Union, Iceland, Norway, Switzerland or Turkey and which were intended for sale in one of these countries; it is valid and enforceable in these countries only.

**Guarantee period:** The Guarantee period begins on the date on which the Product is purchased by an end customer (date of original proof of purchase) and runs for three (3) years, or ninety (90) days for all media on which software for this Product is provided.

**Claiming under the Guarantee:** If you wish to make a claim under this Guarantee, you must, within thirty (30) days of the occurrence of a defect, submit the following to an authorized ZF Electronics customer service office: the Product and the original proof of purchase. This must show the name and address of the authorized ZF Electronics salesperson and the date and place of purchase as well as the unique product designation. Responsibility for loss or damage to the Product is not transferred to ZF Electronics until the product has reached ZF Electronics.

**Guarantee benefits:** Defects in the material, construction or processing of the hardware will be remedied within the Guarantee period by ZF Electronics or by an authorized ZF Electronics customer service office free of charge within a commercially acceptable period by repair to the extent necessary to restore operation, or, should ZF Electronics at its own discretion consider it necessary, by replacing the Product or parts of it. If neither of these two possibilities is feasible, ZF Electronics will reimburse the customer the purchase price paid. Replacement products may also be products which were state-of-the-art at the time of the purchase of the Product to be replaced. ZF Electronics may use new, refurbished or as-new products or parts for the repair and replacement of the Product. As far as legally possible, ZF Electronics may choose between the possibilities mentioned above at its own discretion.

Replaced parts or Products are guaranteed either until the end of the original Guarantee period for the original Product or for three (3) months from the exchange of the parts or Products, whichever Guarantee period is longer.

Exchanged or returned parts or pieces of equipment become the property of ZF Electronics.

Defects in parts subject to wear and tear, which by their nature have only a limited service life (e.g. batteries or fuses), are not covered by the Guarantee. Products from third parties supplied together with the Product under Guarantee are not covered by the Guarantee from ZF Electronics.

Furthermore, the Guarantee does not cover normal wear and tear. Additionally, the Guarantee from ZF Electronics does not apply if the defect is the result of disregard of the instructions for use, improper or rough treatment or attempts at modification, e.g. using sharp objects, bending, pressure or dropping, of unauthorized interference or attempts at connection, unauthorized opening or repair or attempted repair with non-approved spare parts, incorrect operation or faulty installation. Nor does the Guarantee cover cases where the

Product has been exposed to moisture, damp, extreme heat or extreme climatic conditions or short fluctuations of these influences, corrosion or oxidation, where food or liquids have been spilled over it or it has been attacked by chemical substances.

**Limitation of liability:** ZF Electronics liability is limited to the original purchase price of the Product.

to the legally permitted extent, ZF Electronics also precludes liability for any accompanying or resulting damage, indirect or other damage and the shortfall or loss of income or profit, the loss of information or data or other financial damage incurred in connection with the purchase, installation, maintenance or use of the product, in particular higher costs or expenditure on indirect losses or damage, even if ZF Electronics has been informed of the possibility of such damage.

The limitation and preclusion of liability shall apply even if a remedy provided under the Guarantee has not fulfilled its purpose.

ZF Electronics is under no circumstances responsible for the customer's software, information or data stored on or integrated into the Product returned to ZF Electronics.

The limitations of liability detailed above do not apply in cases of intent or gross negligence on the part of ZF Electronics or in the case of death or injury to persons.

**No guarantee on operator software:** This Product may contain software from third-party providers whose use is regulated through a separate licence contract, or it may be connected to software of this kind. The Guarantee granted by ZF Electronics does not cover such third-party software, regardless of whether it is contained in the product or has been downloaded on to the product and regardless of whether it was added during installation, assembly, transport or at any other time in the delivery chain or was received by the purchaser in another way. Information concerning the guarantee applicable in this case may be obtained from the licence contract with the end user, which regulates the use of software of this type.

**Further information:** This Guarantee contains the sole and exclusive legal remedy of the purchaser towards ZF Electronics and ZF Electronics sole and exclusive liability for defects in the product. This Guarantee replaces all other guarantees and declarations of liability where these were made in verbal, written or implied form or are based on (non-mandatory) applicable statutory or contractual provisions. It also replaces implied guarantees of the marketable quality of the Product or its suitability for a particular purpose.

No ZF Electronics distributor, sales agent or employee is authorized to grant amendments, extensions or supplements to this Guarantee.

Information on the conditions of the Guarantee, authorized customer service offices and any up-dates may be obtained from our web site at: [www.cherry.de/guarantee/](http://www.cherry.de/guarantee/).