



Cisco Nexus 2000 Series Hardware Installation Guide

February, 2015

Cisco Systems, Inc.

www.cisco.com

Cisco has more than 200 offices worldwide. Addresses, phone numbers, and fax numbers are listed on the Cisco website at www.cisco.com/go/offices.

THE SPECIFICATIONS AND INFORMATION REGARDING THE PRODUCTS IN THIS MANUAL ARE SUBJECT TO CHANGE WITHOUT NOTICE. ALL STATEMENTS, INFORMATION, AND RECOMMENDATIONS IN THIS MANUAL ARE BELIEVED TO BE ACCURATE BUT ARE PRESENTED WITHOUT WARRANTY OF ANY KIND, EXPRESS OR IMPLIED. USERS MUST TAKE FULL RESPONSIBILITY FOR THEIR APPLICATION OF ANY PRODUCTS.

THE SOFTWARE LICENSE AND LIMITED WARRANTY FOR THE ACCOMPANYING PRODUCT ARE SET FORTH IN THE INFORMATION PACKET THAT SHIPPED WITH THE PRODUCT AND ARE INCORPORATED HEREIN BY THIS REFERENCE. IF YOU ARE UNABLE TO LOCATE THE SOFTWARE LICENSE OR LIMITED WARRANTY, CONTACT YOUR CISCO REPRESENTATIVE FOR A COPY.

The following information is for FCC compliance of Class A devices: This equipment has been tested and found to comply with the limits for a Class A digital device, pursuant to part 15 of the FCC rules. These limits are designed to provide reasonable protection against harmful interference when the equipment is operated in a commercial environment. This equipment generates, uses, and can radiate radio-frequency energy and, if not installed and used in accordance with the instruction manual, may cause harmful interference to radio communications. Operation of this equipment in a residential area is likely to cause harmful interference, in which case users will be required to correct the interference at their own expense.

The following information is for FCC compliance of Class B devices: The equipment described in this manual generates and may radiate radio-frequency energy. If it is not installed in accordance with Cisco's installation instructions, it may cause interference with radio and television reception. This equipment has been tested and found to comply with the limits for a Class B digital device in accordance with the specifications in part 15 of the FCC rules. These specifications are designed to provide reasonable protection against such interference in a residential installation. However, there is no guarantee that interference will not occur in a particular installation.

Modifying the equipment without Cisco's written authorization may result in the equipment no longer complying with FCC requirements for Class A or Class B digital devices. In that event, your right to use the equipment may be limited by FCC regulations, and you may be required to correct any interference to radio or television communications at your own expense.

You can determine whether your equipment is causing interference by turning it off. If the interference stops, it was probably caused by the Cisco equipment or one of its peripheral devices. If the equipment causes interference to radio or television reception, try to correct the interference by using one or more of the following measures:

- Turn the television or radio antenna until the interference stops.
- Move the equipment to one side or the other of the television or radio.
- Move the equipment farther away from the television or radio.
- Plug the equipment into an outlet that is on a different circuit from the television or radio. (That is, make certain the equipment and the television or radio are on circuits controlled by different circuit breakers or fuses.)

Modifications to this product not authorized by Cisco Systems, Inc. could void the FCC approval and negate your authority to operate the product.

The Cisco implementation of TCP header compression is an adaptation of a program developed by the University of California, Berkeley (UCB) as part of UCB's public domain version of the UNIX operating system. All rights reserved. Copyright © 1981, Regents of the University of California.

NOTWITHSTANDING ANY OTHER WARRANTY HEREIN, ALL DOCUMENT FILES AND SOFTWARE OF THESE SUPPLIERS ARE PROVIDED "AS IS" WITH ALL FAULTS. CISCO AND THE ABOVE-NAMED SUPPLIERS DISCLAIM ALL WARRANTIES, EXPRESSED OR IMPLIED, INCLUDING, WITHOUT LIMITATION, THOSE OF MERCHANTABILITY, FITNESS FOR A PARTICULAR PURPOSE AND NONINFRINGEMENT OR ARISING FROM A COURSE OF DEALING, USAGE, OR TRADE PRACTICE.

IN NO EVENT SHALL CISCO OR ITS SUPPLIERS BE LIABLE FOR ANY INDIRECT, SPECIAL, CONSEQUENTIAL, OR INCIDENTAL DAMAGES, INCLUDING, WITHOUT LIMITATION, LOST PROFITS OR LOSS OR DAMAGE TO DATA ARISING OUT OF THE USE OR INABILITY TO USE THIS MANUAL, EVEN IF CISCO OR ITS SUPPLIERS HAVE BEEN ADVISED OF THE POSSIBILITY OF SUCH DAMAGES.

Cisco and the Cisco logo are trademarks or registered trademarks of Cisco and/or its affiliates in the U.S. and other countries. To view a list of Cisco trademarks, go to this URL: www.cisco.com/go/trademarks. Third-party trademarks mentioned are the property of their respective owners. The use of the word partner does not imply a partnership relationship between Cisco and any other company. (1110R)

Any Internet Protocol (IP) addresses used in this document are not intended to be actual addresses. Any examples, command display output, and figures included in the document are shown for illustrative purposes only. Any use of actual IP addresses in illustrative content is unintentional and coincidental.

Cisco Nexus 2000 Series Fabric Extender

© 2010-2015 Cisco Systems, Inc. All rights reserved.



Preface ix

Audience ix

Organization ix

Conventions x

Related Documentation xvi

Obtaining Documentation and Submitting a Service Request xvii

CHAPTER 1

Using a Fabric Extender with a Cisco Nexus 5000 Series or Cisco Nexus 6000 Series Switch 1-1

Information About Using a Fabric Extender with a Cisco Nexus Switch 1-1

Cisco Nexus 2300 Series 1-1

Chassis 1-2

Ports 1-5

Power Supplies 1-6

Fans 1-9

Supported Transceivers and Cables 1-10

Cisco Nexus 2248TP-E 1-10

Chassis 1-10

Ports 1-12

Power Supplies 1-12

Fan Trays 1-15

Supported Transceivers and Cables 1-17

Cisco Nexus 2248TP 1-17

Chassis 1-18

Ports 1-19

Power Supplies 1-19

Fan Tray 1-22

Supported Transceivers and Cables 1-24

Cisco Nexus 2248PQ 1-24

Chassis 1-25

Ports 1-25

Power Supplies 1-25

Fan Trays 1-26

Supported SFP+ Transceivers 1-27

Cisco Nexus 2232TM-10GE, Cisco Nexus N2K-C2232TM-E-10GE	1-27
Chassis	1-27
Ports	1-29
Power Supplies	1-30
Fan Trays	1-31
Supported Transceivers and Cables	1-32
Cisco Nexus 2224TP	1-32
Chassis	1-33
Ports	1-34
Power Supplies	1-34
Fan Tray	1-35
Supported SFP+ Transceivers	1-36
Cisco Nexus 2148T	1-36
Features	1-36
Chassis	1-36
Ports	1-38
Power Supplies	1-38
Fan Tray	1-39
Supported SFP Transceivers	1-40

CHAPTER 2

Using a Fabric Extender with a Cisco Nexus 7000 Series Switch 2-1

Information About Using a Fabric Extender with a Cisco Nexus 7000 Series Switch	2-1
Cisco Nexus 2248TP-E FEX	2-2
Ports for the Cisco Nexus 2248TP-E FEX	2-4
Power Supplies for the Cisco Nexus 2248TP-E FEX	2-4
Fan Tray for the Cisco Nexus 2248TP-E FEX	2-7
Transceivers and Connectors Supported by the Cisco Nexus 2248TP-E FEX	2-9
Cisco Nexus 2248TP FEX	2-11
Ports for the Cisco Nexus 2248TP FEX	2-13
Power Supplies for the Cisco Nexus 2248TP FEX	2-14
Fan Tray for the Cisco Nexus 2248TP FEX	2-14
Transceivers and Connectors Supported by the Cisco Nexus 2248TP FEX	2-15
Cisco Nexus 2232TM FEX	2-15
Ports for the Cisco Nexus 2232TM FEX	2-17
Power Supplies for the Cisco Nexus 2232TM FEX	2-18
Fan Tray for the Cisco Nexus 2232TM FEX	2-19
Transceivers and Connectors Supported by the Cisco Nexus 2232TM FEX	2-20
Cisco Nexus 2232PP FEX	2-22
Ports for the Cisco Nexus 2232PP FEX	2-24

Power Supplies for the Cisco Nexus 2232PP FEX	2-25
Fan Tray for the Cisco Nexus 2232PP FEX	2-26
Transceivers Supported by the Cisco Nexus 2232PP FEX	2-26
Cisco Nexus 2224TP FEX	2-27
Ports for the Cisco Nexus 2224TP FEX	2-29
Power Supplies for the Cisco Nexus 2224TP FEX	2-30
Fan Tray for the Cisco Nexus 2224TP FEX	2-31
Transceivers and Connectors Supported by the Cisco Nexus 2224TP FEX	2-31

CHAPTER 3**Using a Fabric Extender with a Cisco Nexus 9000 Series Switch 3-1**

Information About Using a Fabric Extender with a Cisco Nexus 9396PX Switch	3-1
Cisco Nexus 2248TP-E FEX	3-1
Ports for the Cisco Nexus 2248TP-E FEX	3-3
Power Supplies for the Cisco Nexus 2248TP-E FEX	3-4
Fan Tray for the Cisco Nexus 2248TP-E FEX	3-6
Transceivers and Connectors Supported by the Cisco Nexus 2248TP-E FEX	3-8
Cisco Nexus 2248TP FEX	3-10
Ports for the Cisco Nexus 2248TP FEX	3-12
Power Supplies for the Cisco Nexus 2248TP FEX	3-13
Fan Tray for the Cisco Nexus 2248TP FEX	3-13
Transceivers and Connectors Supported by the Cisco Nexus 2248TP FEX	3-13
Cisco Nexus 2232TM FEX	3-15
Ports for the Cisco Nexus 2232TM FEX	3-17
Power Supplies for the Cisco Nexus 2232TM FEX	3-17
Fan Tray for the Cisco Nexus 2232TM FEX	3-18
Transceivers and Connectors Supported by the Cisco Nexus 2232TM FEX	3-19
Cisco Nexus 2232PP FEX	3-21
Ports for the Cisco Nexus 2232PP FEX	3-22
Power Supplies for the Cisco Nexus 2232PP FEX	3-23
Fan Tray for the Cisco Nexus 2232PP FEX	3-23
Transceivers Supported by the Cisco Nexus 2232PP FEX	3-24
Cisco Nexus 2224TP FEX	3-25
Ports for the Cisco Nexus 2224TP FEX	3-27
Power Supplies for the Cisco Nexus 2224TP FEX	3-28
Fan Tray for the Cisco Nexus 2224TP FEX	3-28
Transceivers and Connectors Supported by the Cisco Nexus 2224TP FEX	3-28

CHAPTER 4**Installing a Cisco Nexus Fabric Extender 4-1**

Preparing for Installation	4-2
----------------------------	-----

- Installation Options 4-2
- Airflow Considerations 4-2
- Chassis Weight 4-3
- Installation Guidelines 4-3
- Required Tools and Equipment 4-4
- Unpacking and Inspecting the Cisco Nexus Fabric Extender 4-5
- Installing the Cisco Nexus Fabric Extender Chassis in a Cabinet or Rack 4-6
- Grounding the System 4-7
 - Proper Grounding Guidelines 4-8
 - Preventing Electrostatic Discharge Damage 4-9
 - Establishing the System Ground 4-13
 - Required Tools and Equipment 4-13
- Grounding the Chassis 4-14
- Starting the Cisco Nexus Fabric Extender 4-14
- Removing and Installing Components 4-16
 - Removing and Installing Power Supplies 4-16
 - Removing an AC Power Supply 4-17
 - Installing an AC Power Supply 4-17
 - Removing a DC Power Supply 4-18
 - Installing a DC Power Supply 4-19
 - Removing and Installing a Fan 4-19
 - Removing a Fan 4-20
 - Installing a Fan 4-20
 - Removing and Installing the Fan Tray 4-21
 - Removing a Fan Tray 4-21
 - Installing a Fan Tray 4-22
 - Removing the Cisco Nexus Fabric Extender 4-22
- Repacking the Cisco Nexus Fabric Extender for Return Shipment 4-23

CHAPTER 5

Connecting a Cisco Nexus Fabric Extender 5-1

- Preparing for Network Connections 5-2
- Connecting to the 1-Gigabit Ethernet Port 5-2
- Connecting to a 10-Gigabit and 40-Gigabit Ethernet Port 5-2
 - Removing and Installing SFP+ Transceivers 5-2
 - Installing an SFP+ Transceiver 5-3
 - Removing an SFP+ Transceiver 5-3
 - Removing and Installing Cables into SFP+ Transceivers 5-4
 - Removing a Cable from an SFP+ Transceiver 5-5
 - Installing a Cable into an SFP+ Transceiver 5-5

Maintaining SFP+ Transceivers and Cables 5-6

APPENDIX A

Cabinet and Rack Installation A-1

- Cabinet and Rack Requirements A-1
 - General Requirements for Cabinets and Racks A-1
 - Requirements Specific to Perforated Cabinets A-2
 - Requirements Specific to Standard Open Racks A-2
- Cable Management Guidelines A-3

APPENDIX B

Technical Specifications B-1

- Power Specifications B-1
- Environmental Specifications B-6
- Physical Specifications B-6
- Transceiver Specifications B-7
 - SFP+ Optical Transceiver Specifications B-8
 - SFP+ Copper Transceiver Specifications B-8
- Airflow Optimization Accessories B-9

APPENDIX C

Cable and Port Specifications C-1

- Supported Power Cords and Plugs C-1
 - Power Cords C-1
- Jumper Power Cord C-8

APPENDIX D

Troubleshooting Hardware Components D-1

- Overview D-1
- SNMP Traps D-1
- Device Hardware Guidelines D-2
 - Installation D-2
 - Initialization D-2
 - Device Operation D-2
- Contacting Customer Service D-3

APPENDIX E

LEDs E-1

- Chassis and Module LEDs for the Cisco Nexus Fabric Extenders E-1
 - Chassis and Module LED Descriptions E-2
 - Power Supply Status E-3
- Port LEDs E-4

Ethernet Port LEDs E-4
Ethernet and Fibre Channel LEDs E-4

APPENDIX F

Accessory Kit F-7

Accessory Kit for Cisco Nexus 2300 Series FEXs F-7
Accessory Kit for Cisco Nexus 2248TP-E, 2224TP, 2232PP, 2248TP, 2232TM, and 2148T F-8

APPENDIX G

Site Preparation and Maintenance Records G-1

Site Preparation Checklist G-1
Contact and Site Information G-3
Chassis and Module Information G-3



Preface

This preface describes the audience, organization, and conventions of the *Cisco Nexus 2000 Series Hardware Installation Guide*. It also provides information on how to obtain related documentation.

This preface includes the following sections:

- [Audience, page ix](#)
- [Organization, page ix](#)
- [Conventions, page x](#)
- [Related Documentation, page xvi](#)
- [Obtaining Documentation and Submitting a Service Request, page xvii](#)

Audience

To use this installation guide, you must be familiar with electronic circuitry and wiring practices and preferably be an electronic or electromechanical technician.

Organization

This guide is organized as follows:

Chapter and Title	Description
Chapter 1, “Using a Fabric Extender with a Cisco Nexus 5000 Series or Cisco Nexus 6000 Series Switch”	Provides an overview of the Cisco Nexus 2000 Series Fabric Extenders and their components as used with the Cisco Nexus 5000 Series switches.
Chapter 2, “Using a Fabric Extender with a Cisco Nexus 7000 Series Switch”	Provides an overview of the Cisco Nexus 2000 Series Fabric Extenders and their components as used with the Cisco Nexus 7000 Series switches.
Chapter 3, “Using a Fabric Extender with a Cisco Nexus 9000 Series Switch”	Provides an overview of the Cisco Nexus 2000 Series Fabric Extenders and their components as used with the Cisco Nexus 9000 Series switches.
Chapter 4, “Installing a Cisco Nexus Fabric Extender”	Describes how to install the Cisco Nexus 2000 Series Fabric Extenders, and how to install modules, power supplies, and fan assemblies.

Chapter and Title	Description
Chapter 5, “ Connecting a Cisco Nexus Fabric Extender ”	Describes how to connect the Cisco Nexus 2000 Series Fabric Extenders, including the modules.
Appendix A, “ Cabinet and Rack Installation ”	Provides guidelines for selecting an enclosed cabinet, and a procedure for installing a switch using the optional and EIA Shelf Bracket Kit.
Appendix B, “ Technical Specifications ”	Lists specifications for the Cisco Nexus 2000 Series Fabric Extenders and components including modules, power supplies, and transceivers.
Appendix C, “ Cable and Port Specifications ”	Lists cable and port specifications for the Cisco Nexus 2000 Series Fabric Extenders.
Appendix D, “ Troubleshooting Hardware Components ”	Describes how to identify and resolve problems that might occur with the hardware components of the Cisco Nexus 2000 Series Fabric Extenders.
Appendix E, “ LEDs ”	Describes the conditions indicated by the chassis and module LEDs on the Cisco Nexus 2000 Series Fabric Extenders.
Appendix F, “ Accessory Kit ”	Lists the accessory kit contents for the Cisco Nexus 2000 Series Fabric Extenders.
Appendix G, “ Site Preparation and Maintenance Records ”	Provides site preparation information for the Cisco Nexus 2000 Series Fabric Extenders.

Conventions

This document uses the following conventions for notes, cautions, and safety warnings.

Notes and Cautions contain important information that you should be aware of.



Note

Means *reader take note*. Notes contain helpful suggestions or references to material that are not covered in the publication.



Caution

Means *reader be careful*. You are capable of doing something that might result in equipment damage or loss of data.

Safety warnings appear throughout this publication in procedures that, if performed incorrectly, can cause physical injuries. A warning symbol precedes each warning statement.



Warning

IMPORTANT SAFETY INSTRUCTIONS

This warning symbol means danger. You are in a situation that could cause bodily injury. Before you work on any equipment, be aware of the hazards involved with electrical circuitry and be familiar with standard practices for preventing accidents. Use the statement number provided at the end of each warning to locate its translation in the translated safety warnings that accompanied this device. Statement 1071

SAVE THESE INSTRUCTIONS

Waarschuwing

BELANGRIJKE VEILIGHEIDSINSTRUCTIES

Dit waarschuwingssymbool betekent gevaar. U verkeert in een situatie die lichamelijk letsel kan veroorzaken. Voordat u aan enige apparatuur gaat werken, dient u zich bewust te zijn van de bij elektrische schakelingen betrokken risico's en dient u op de hoogte te zijn van de standaard praktijken om ongelukken te voorkomen. Gebruik het nummer van de verklaring onderaan de waarschuwing als u een vertaling van de waarschuwing die bij het apparaat wordt geleverd, wilt raadplegen.

BEWAAR DEZE INSTRUCTIES

Varoitus

TÄRKEITÄ TURVALLISUUSOHJEITA

Tämä varoitusmerkki merkitsee vaaraa. Tilanne voi aiheuttaa ruumiillisia vammoja. Ennen kuin käsittelet laitteistoa, huomioi sähköpiirien käsittelyyn liittyvät riskit ja tutustu onnettomuuksien yleisiin ehkäisytapoihin. Turvallisuusvaroitusten käännökset löytyvät laitteen mukana toimitettujen käännettyjen turvallisuusvaroitusten joukosta varoitusten lopussa näkyvien lausuntonumeroiden avulla.

SÄILYTÄ NÄMÄ OHJEET

Attention

IMPORTANTES INFORMATIONS DE SÉCURITÉ

Ce symbole d'avertissement indique un danger. Vous vous trouvez dans une situation pouvant entraîner des blessures ou des dommages corporels. Avant de travailler sur un équipement, soyez conscient des dangers liés aux circuits électriques et familiarisez-vous avec les procédures couramment utilisées pour éviter les accidents. Pour prendre connaissance des traductions des avertissements figurant dans les consignes de sécurité traduites qui accompagnent cet appareil, référez-vous au numéro de l'instruction situé à la fin de chaque avertissement.

CONSERVEZ CES INFORMATIONS

Warnung

WICHTIGE SICHERHEITSHINWEISE

Dieses Warnsymbol bedeutet Gefahr. Sie befinden sich in einer Situation, die zu Verletzungen führen kann. Machen Sie sich vor der Arbeit mit Geräten mit den Gefahren elektrischer Schaltungen und den üblichen Verfahren zur Vorbeugung vor Unfällen vertraut. Suchen Sie mit der am Ende jeder Warnung angegebenen Anweisungsnummer nach der jeweiligen Übersetzung in den übersetzten Sicherheitshinweisen, die zusammen mit diesem Gerät ausgeliefert wurden.

BEWAHREN SIE DIESE HINWEISE GUT AUF.

Avvertenza IMPORTANTI ISTRUZIONI SULLA SICUREZZA

Questo simbolo di avvertenza indica un pericolo. La situazione potrebbe causare infortuni alle persone. Prima di intervenire su qualsiasi apparecchiatura, occorre essere al corrente dei pericoli relativi ai circuiti elettrici e conoscere le procedure standard per la prevenzione di incidenti. Utilizzare il numero di istruzione presente alla fine di ciascuna avvertenza per individuare le traduzioni delle avvertenze riportate in questo documento.

CONSERVARE QUESTE ISTRUZIONI

Advarsel VIKTIGE SIKKERHETSINSTRUKSJONER

Dette advarselssymbolet betyr fare. Du er i en situasjon som kan føre til skade på person. Før du begynner å arbeide med noe av utstyret, må du være oppmerksom på farene forbundet med elektriske kretser, og kjenne til standardprosedyrer for å forhindre ulykker. Bruk nummeret i slutten av hver advarsel for å finne oversettelsen i de oversatte sikkerhetsadvarslene som fulgte med denne enheten.

TA VARE PÅ DISSE INSTRUKSJONENE

Aviso INSTRUÇÕES IMPORTANTES DE SEGURANÇA

Este símbolo de aviso significa perigo. Você está em uma situação que poderá ser causadora de lesões corporais. Antes de iniciar a utilização de qualquer equipamento, tenha conhecimento dos perigos envolvidos no manuseio de circuitos elétricos e familiarize-se com as práticas habituais de prevenção de acidentes. Utilize o número da instrução fornecido ao final de cada aviso para localizar sua tradução nos avisos de segurança traduzidos que acompanham este dispositivo.

GUARDE ESTAS INSTRUÇÕES

¡Advertencia! INSTRUCCIONES IMPORTANTES DE SEGURIDAD

Este símbolo de aviso indica peligro. Existe riesgo para su integridad física. Antes de manipular cualquier equipo, considere los riesgos de la corriente eléctrica y familiarícese con los procedimientos estándar de prevención de accidentes. Al final de cada advertencia encontrará el número que le ayudará a encontrar el texto traducido en el apartado de traducciones que acompaña a este dispositivo.

GUARDE ESTAS INSTRUCCIONES

Varning! VIKTIGA SÄKERHETSANVISNINGAR

Denna varningssignal signalerar fara. Du befinner dig i en situation som kan leda till personskada. Innan du utför arbete på någon utrustning måste du vara medveten om farorna med elkretsar och känna till vanliga förfaranden för att förebygga olyckor. Använd det nummer som finns i slutet av varje varning för att hitta dess översättning i de översatta säkerhetsvarningar som medföljer denna anordning.

SPARA DESSA ANVISNINGAR

Figyelem FONTOS BIZTONSÁGI ELOÍRÁSOK

Ez a figyelmeztető jel veszélyre utal. Sérülésveszélyt rejtő helyzetben van. Mielőtt bármely berendezésen munkát végezte, legyen figyelemmel az elektromos áramkörök okozta kockázatokra, és ismerkedjen meg a szokásos balesetvédelmi eljárásokkal. A kiadványban szereplő figyelmeztetések fordítása a készülékhez mellékelt biztonsági figyelmeztetések között található; a fordítás az egyes figyelmeztetések végén látható szám alapján kereshető meg.

ORIZZE MEG EZEKET AZ UTASÍTÁSOKAT!

Предупреждение ВАЖНЫЕ ИНСТРУКЦИИ ПО СОБЛЮДЕНИЮ ТЕХНИКИ БЕЗОПАСНОСТИ

Этот символ предупреждения обозначает опасность. То есть имеет место ситуация, в которой следует опасаться телесных повреждений. Перед эксплуатацией оборудования выясните, каким опасностям может подвергаться пользователь при использовании электрических цепей, и ознакомьтесь с правилами техники безопасности для предотвращения возможных несчастных случаев. Воспользуйтесь номером заявления, приведенным в конце каждого предупреждения, чтобы найти его переведенный вариант в переводе предупреждений по безопасности, прилагаемом к данному устройству.

СОХРАНИТЕ ЭТИ ИНСТРУКЦИИ

警告 重要的安全性说明

此警告符号代表危险。您正处于可能受到严重伤害的工作环境中。在您使用设备开始工作之前，必须充分意识到触电的危险，并熟练掌握防止事故发生的标准工作程序。请根据每项警告结尾提供的声明号码来找到此设备的安全性警告说明的翻译文本。

请保存这些安全性说明

警告 安全上の重要な注意事項

「危険」の意味です。人身事故を予防するための注意事項が記述されています。装置の取り扱い作業を行うときは、電気回路の危険性に注意し、一般的な事故防止策に留意してください。警告の各国語版は、各注意事項の番号を基に、装置に付属の「Translated Safety Warnings」を参照してください。

これらの注意事項を保管しておいてください。

주의 중요 안전 지침

이 경고 기호는 위험을 나타냅니다. 작업자가 신체 부상을 일으킬 수 있는 위험한 환경에 있습니다. 장비에 작업을 수행하기 전에 전기 회로와 관련된 위험을 숙지하고 표준 작업 관례를 숙지하여 사고를 방지하십시오. 각 경고의 마지막 부분에 있는 경고문 번호를 참조하여 이 장치와 함께 제공되는 번역된 안전 경고문에서 해당 번역문을 찾으십시오.

이 지시 사항을 보관하십시오.

Aviso INSTRUÇÕES IMPORTANTES DE SEGURANÇA

Este símbolo de aviso significa perigo. Você se encontra em uma situação em que há risco de lesões corporais. Antes de trabalhar com qualquer equipamento, esteja ciente dos riscos que envolvem os circuitos elétricos e familiarize-se com as práticas padrão de prevenção de acidentes. Use o número da declaração fornecido ao final de cada aviso para localizar sua tradução nos avisos de segurança traduzidos que acompanham o dispositivo.

GUARDE ESTAS INSTRUÇÕES

Advarsel VIGTIGE SIKKERHEDSANVISNINGER

Dette advarselssymbol betyder fare. Du befinder dig i en situation med risiko for legemeskade. Før du begynder arbejde på udstyr, skal du være opmærksom på de involverede risici, der er ved elektriske kredsløb, og du skal sætte dig ind i standardprocedurer til undgåelse af ulykker. Brug erklæringsnummeret efter hver advarsel for at finde oversættelsen i de oversatte advarsler, der fulgte med denne enhed.

GEM DISSE ANVISNINGER

تحذير

إرشادات الأمان الهامة

يوضح رمز التحذير هذا وجود خطر. وهذا يعني أنك متواجد في مكان قد ينتج عنه التعرض لإصابات. قبل بدء العمل، احذر مخاطر التعرض للصدمات الكهربائية وكن على علم بالإجراءات القياسية للحيلولة دون وقوع أي حوادث. استخدم رقم البيان الموجود في آخر كل تحذير لتحديد مكان ترجمته داخل تحذيرات الأمان المترجمة التي تأتي مع الجهاز. قم بحفظ هذه الإرشادات

Upozorenje VAŽNE SIGURNOSNE NAPOMENE

Ovaj simbol upozorenja predstavlja opasnost. Nalazite se u situaciji koja može prouzročiti tjelesne ozljede. Prije rada s bilo kojim uređajem, morate razumjeti opasnosti vezane uz električne sklopove, te biti upoznati sa standardnim načinima izbjegavanja nesreća. U prevedenim sigurnosnim upozorenjima, priloženima uz uređaj, možete prema broju koji se nalazi uz pojedino upozorenje pronaći i njegov prijevod.

SAČUVAJTE OVE UPUTE

Upozornění DŮLEŽITÉ BEZPEČNOSTNÍ POKYNY

Tento upozorňující symbol označuje nebezpečí. Jste v situaci, která by mohla způsobit nebezpečí úrazu. Před prací na jakémkoliv vybavení si uvědomte nebezpečí související s elektrickými obvody a seznamte se se standardními opatřeními pro předcházení úrazům. Podle čísla na konci každého upozornění vyhledejte jeho překlad v přeložených bezpečnostních upozorněních, která jsou přiložena k zařízení.

USCHOVEJTE TYTO POKYNY

Προειδοποίηση

ΣΗΜΑΝΤΙΚΕΣ ΟΔΗΓΙΕΣ ΑΣΦΑΛΕΙΑΣ

Αυτό το προειδοποιητικό σύμβολο σημαίνει κίνδυνο. Βρίσκεστε σε κατάσταση που μπορεί να προκαλέσει τραυματισμό. Πριν εργαστείτε σε οποιοδήποτε εξοπλισμό, να έχετε υπόψη σας τους κινδύνους που σχετίζονται με τα ηλεκτρικά κυκλώματα και να έχετε εξοικειωθεί με τις συνήθεις πρακτικές για την αποφυγή ατυχημάτων. Χρησιμοποιήστε τον αριθμό δήλωσης που παρέχεται στο τέλος κάθε προειδοποίησης, για να εντοπίσετε τη μετάφρασή της στις μεταφρασμένες προειδοποιήσεις ασφαλείας που συνοδεύουν τη συσκευή.

ΦΥΛΑΞΤΕ ΑΥΤΕΣ ΤΙΣ ΟΔΗΓΙΕΣ

אזהרה

הוראות בטיחות חשובות

סימן אזהרה זה מסמל סכנה. אתה נמצא במצב העלול לגרום לפציעה. לפני שתעבוד עם ציוד כלשהו, עליך להיות מודע לסכנות הכרוכות במגעלים חשמליים ולהכיר את הנהלים המקובלים למניעת תאונות. השתמש במספר ההוראה המסופק בסופה של כל אזהרה כדי לאתר את התרגום באזהרות הבטיחות המתורגמות שמצורפות להתקן.

שמור הוראות אלה

Opomena

ВАЖНИ БЕЗБЕДНОСНИ НАПАТСТВИЈА

Симболот за предупредување значи опасност. Се наоѓате во ситуација што може да предизвика телесни повреди. Пред да работите со опремата, бидете свесни за ризикот што постои кај електричните кола и треба да ги познавате стандардните постапки за спречување на несреќни случаи. Искористете го бројот на изјавата што се наоѓа на крајот на секое предупредување за да го најдете неговиот период во преведените безбедносни предупредувања што се испорачани со уредот.

ЧУВАЈТЕ ГИ ОБИЕ НАПАТСТВИЈА

Ostrzeżenie

WAŻNE INSTRUKCJE DOTYCZĄCE BEZPIECZEŃSTWA

Ten symbol ostrzeżenia oznacza niebezpieczeństwo. Zachodzi sytuacja, która może powodować obrażenia ciała. Przed przystąpieniem do prac przy urządzeniach należy zapoznać się z zagrożeniami związanymi z układami elektrycznymi oraz ze standardowymi środkami zapobiegania wypadkom. Na końcu każdego ostrzeżenia podano numer, na podstawie którego można odszukać tłumaczenie tego ostrzeżenia w dołączonym do urządzenia dokumencie z tłumaczeniami ostrzeżeń.

NINIEJSZE INSTRUKCJE NALEŻY ZACHOWAĆ

Upozornenie

DÔLEŽITÉ BEZPEČNOSTNÉ POKYNY

Tento varovný symbol označuje nebezpečenstvo. Nachádzate sa v situácii s nebezpečenstvom úrazu. Pred prácou na akomkoľvek vybavení si uvedomte nebezpečenstvo súvisiace s elektrickými obvodmi a oboznámte sa so štandardnými opatreniami na predchádzanie úrazom. Podľa čísla na konci každého upozornenia vyhľadajte jeho preklad v preložených bezpečnostných upozorneniach, ktoré sú priložené k zariadeniu.

USCHOVAJTE SI TENTO NÁVOD

Opozorilo **POMEMBNI VARNOSTNI NAPOTKI**

Ta opozorilni simbol pomeni nevarnost. Nahajate se v situaciji, kjer lahko pride do telesnih poškodb. Preden pričnete z delom na napravi, se morate zavedati nevarnosti udara električnega toka, ter tudi poznati preventivne ukrepe za preprečevanje takšnih nevarnosti. Uporabite obrazložitevno številko na koncu posameznega opozorila, da najdete opis nevarnosti v priloženem varnostnem priročniku.

SHRANITE TE NAPOTKE!

警告

重要安全性指示

此警告符號代表危險，表示可能造成人身傷害。使用任何設備前，請留心電路相關危險，並熟悉避免意外的標準作法。您可以使用每項警告後的聲明編號，查詢本裝置隨附之安全性警告譯文中的翻譯。請妥善保留此指示

Related Documentation

Documentation for Cisco Nexus 2000 Series Fabric Extenders is available at the following URL:

<http://www.cisco.com/c/en/us/support/switches/nexus-2000-series-fabric-extenders/tsd-products-support-series-home.html>

The following are related Cisco Nexus 2000 Series Fabric Extender documents.

Release Notes

Cisco Nexus 5000 Series and Cisco Nexus 2000 Series Release Notes

Cisco Nexus 5000 Series Switch Release Notes

Configuration Guides

Cisco Nexus 5000 Series Configuration Limits for Cisco NX-OS Release 5.0(2)N1(1)

Cisco Nexus 5000 Series Configuration Limits for Cisco NX-OS Release 4.2(1)N1(1) and Release 4.2(1)N2(1)

Cisco Nexus 5000 Series NX-OS Fibre Channel over Ethernet Configuration Guide

Cisco Nexus 5000 Series NX-OS Layer 2 Switching Configuration Guide

Cisco Nexus 5000 Series NX-OS Multicast Routing Configuration Guide

Cisco Nexus 5000 Series NX-OS Quality of Service Configuration Guide

Cisco Nexus 5000 Series NX-OS SAN Switching Configuration Guide

Cisco Nexus 5000 Series NX-OS Security Configuration Guide

Cisco Nexus 5000 Series NX-OS System Management Configuration Guide

Cisco Nexus 5000 Series NX-OS Unicast Routing Configuration Guide

Cisco Nexus 5000 Series Switch NX-OS Software Configuration Guide

Cisco Nexus 5000 Series Fabric Manager Configuration Guide, Release 3.4(1a)

Cisco Nexus 7000 Series NX-OS Fundamentals Configuration Guide, Release 4.2

Cisco Nexus 2000 Series Fabric Extender Software Configuration Guide

Maintain and Operate Guides

Cisco Nexus 5000 Series NX-OS Operations Guide

Installation and Upgrade Guides

Cisco Nexus 5000 Series and Cisco Nexus 5500 Platform Hardware Installation Guide

Cisco Nexus 2000 Series Hardware Installation Guide

Cisco Nexus 5000 Series NX-OS Software Upgrade and Downgrade Guide, Release 4.2(1)NI(1)

Regulatory Compliance and Safety Information for the Cisco Nexus 5000 Series Switches and Cisco Nexus 2000 Series Fabric Extenders

Licensing Guide

Cisco NX-OS Licensing Guide

Command References

Cisco Nexus 5000 Series Command Reference

Technical References

Cisco Nexus 5000 Series and Cisco Nexus 2000 Series Fabric Extender MIBs Reference

Error and System Messages

Cisco NX-OS System Messages Reference

Troubleshooting Guide

Cisco Nexus 5000 Troubleshooting Guide

Obtaining Documentation and Submitting a Service Request

For information on obtaining documentation, submitting a service request, and gathering additional information, see the monthly *What's New in Cisco Product Documentation*, which also lists all new and revised Cisco technical documentation, at:

<http://www.cisco.com/c/en/us/td/docs/general/whatsnew/whatsnew.html>

Subscribe to the *What's New in Cisco Product Documentation* as a Really Simple Syndication (RSS) feed and set content to be delivered directly to your desktop using a reader application. The RSS feeds are a free service and Cisco currently supports RSS Version 2.0.

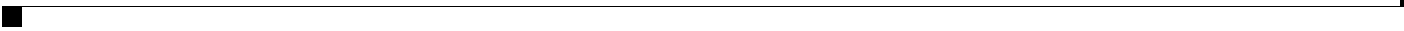



Using a Fabric Extender with a Cisco Nexus 5000 Series or Cisco Nexus 6000 Series Switch

This chapter describes the Cisco Nexus Fabric Extenders (FEXs) and includes these sections:

- [Information About Using a Fabric Extender with a Cisco Nexus Switch, page 1-1](#)
- [Cisco Nexus 2300 Series, page 1-1](#)
- [Cisco Nexus 2248TP-E, page 1-10](#)
- [Cisco Nexus 2248TP, page 1-17](#)
- [Cisco Nexus 2248PQ, page 1-24](#)
- [Cisco Nexus 2232TM-10GE, Cisco Nexus N2K-C2232TM-E-10GE, page 1-27](#)
- [Cisco Nexus 2224TP, page 1-32](#)
- [Cisco Nexus 2148T, page 1-36](#)

Information About Using a Fabric Extender with a Cisco Nexus Switch

The Cisco Nexus Fabric Extenders (FEXs) support Gigabit Ethernet and 10-Gigabit Ethernet environments while allowing transparent migration to 10-Gigabit Ethernet virtual machine aware unified fabric technologies. The Cisco Nexus FEXs behave as remote I/O modules for a parent Cisco Nexus switch. The FEX is an extension of the parent Cisco Nexus switch fabric, with the FEX and the parent Cisco Nexus switch together forming a virtual modular system.

A Cisco Nexus FEX forwards all the traffic to the parent Cisco Nexus Switch over 10-Gigabit Ethernet uplinks. Passing all traffic to the parent switch allows traffic to be shaped according to policies established on the parent Cisco Nexus switch with a single point of management.

Cisco Nexus 2300 Series

The Cisco Nexus 2300 Series FEXs are stackable, hardware capable, 1 RU FEXs that support 48 1/10G host ports as well as up to 6 40G uplink ports towards the parent switch. The 40G uplinks support bi-di optics for seamlessly connectivity. The platform has a deep 32MB shared buffer for increased performance.

The Cisco Nexus 2348TQ provides 48 1/10GBASE-T host ports, while the Cisco Nexus 2348UPQ provides 48 1/10G host unified ports. The unified ports provide native Fibre Channel as well as 1/10G Ethernet and FCoE connectivity options.

You can order the platform with port side exhaust or port side intake air cooling. The port side exhaust cooling model is compatible with data center hot-aisle and cold-aisle designs. This orientation places the ports on the hot aisle aligned with the server ports. Port side intake airflow is used in network rack designs in the data center such that the ports face the cold aisle. The Cisco Nexus 2300 Series is built for non-stop operation, with redundant hot-swappable power supplies and redundant hot-swappable fans.

The Cisco Nexus 2300 Series platform is managed and configured by the upstream switch. The FEX software ships with the Cisco Nexus switch software. The FEX downloads the software image from the switch the same way that a module would download it from the supervisor in a modular chassis.

**Note**

For the most current list of supported features, refer to the latest [Cisco Nexus 2000 Series Fabric Extenders Release Notes](#) at every release.

This section includes the following topics:

- [Chassis, page 1-2](#)
- [Ports, page 1-5](#)
- [Power Supplies, page 1-6](#)
- [Fans, page 1-9](#)
- [Supported Transceivers and Cables, page 1-10](#)

Chassis

The Cisco Nexus 2300 Series platform has a one-rack-unit (1 RU) form factor that takes up relatively little space, making it easy to incorporate into rack designs. The FEX is mounted in a standard 19-inch (48.26 cm) rack. All switch ports at the rear of the unit are in close proximity to server ports, and all user-serviceable components are accessible from the fan side panel.

You can order it with port side exhaust or port side intake air cooling, and with AC or DC power supplies. The port side intake cooling model is intended for installations or deployments where the ports are in the cold aisle, and the fans and power supplies are in the warm aisle.

[Figure 1-1](#) and [Figure 1-2](#) show the fan side view of the Cisco Nexus 2300 Series chassis. [Figure 1-3](#) and [Figure 1-4](#) show the port side view of the Cisco Nexus 2348TQ chassis, and [Figure 1-5](#) and [Figure 1-6](#) show the port side view of the Cisco Nexus 2348UPQ chassis.

Figure 1-1 Fan Side View of the Cisco Nexus 2300 Series Chassis

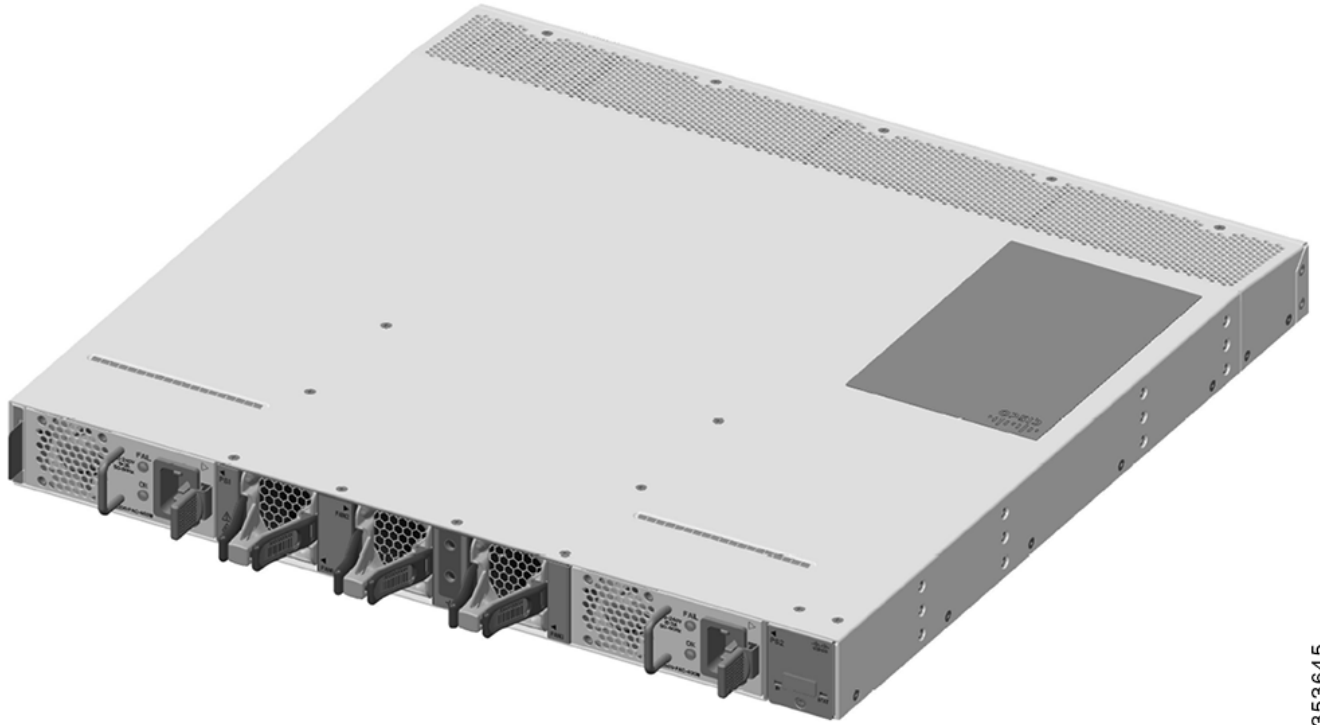

353645

Figure 1-2 Close up of Fan Side View of the Cisco Nexus 2300 Series Chassis

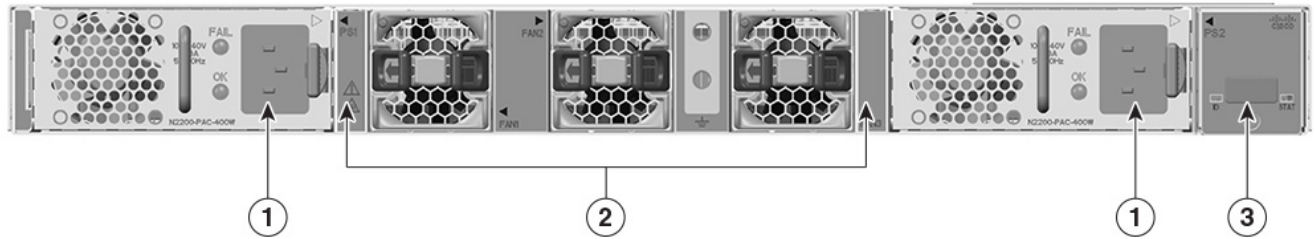

353642

1	Power supply (two 1+1 redundant, hot-swappable power supplies)
2	Fans (three, hot-swappable independent fans with support for 2+1 redundancy)
3	Mgmt/Console port

Figure 1-3 Port Side View of the Cisco Nexus 2348TQ Chassis

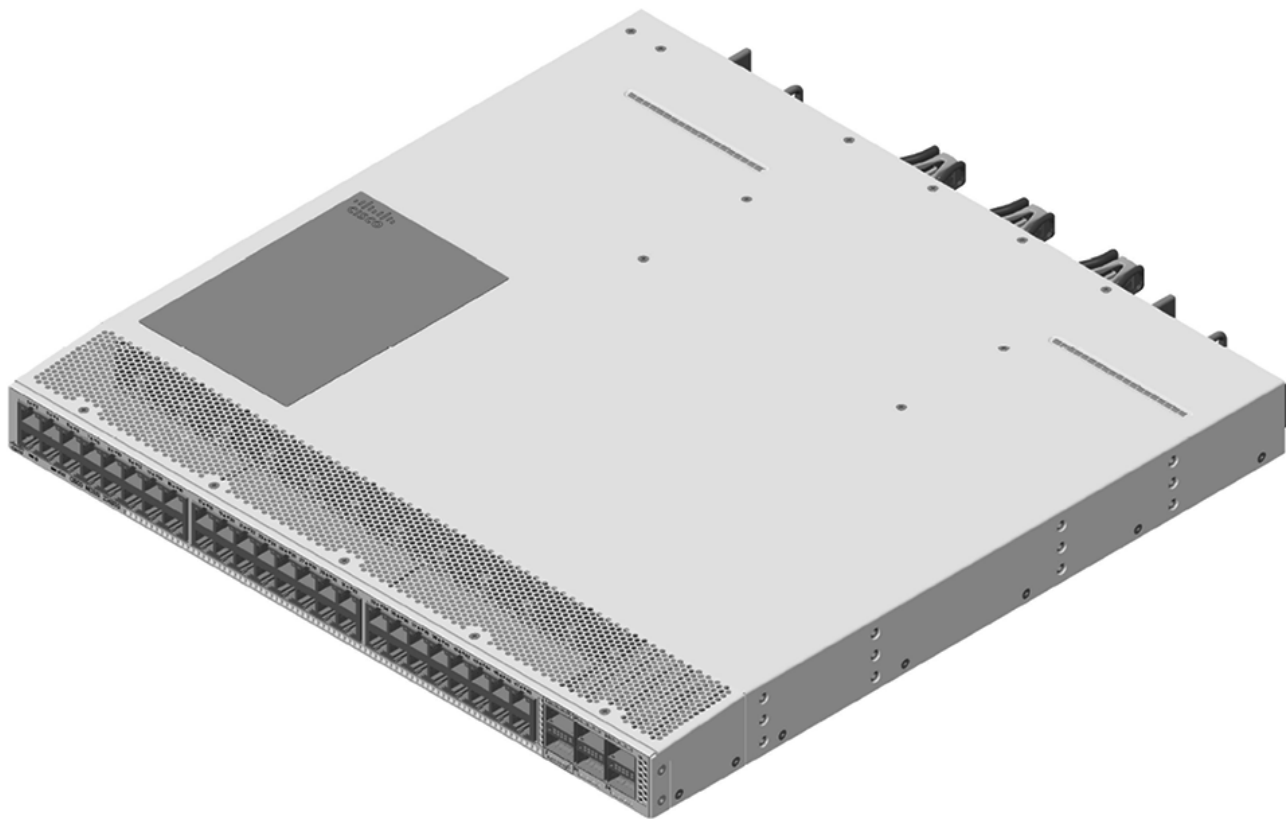

353644

Figure 1-4 Close up of Port Side View of the Cisco Nexus 2348TQ Chassis

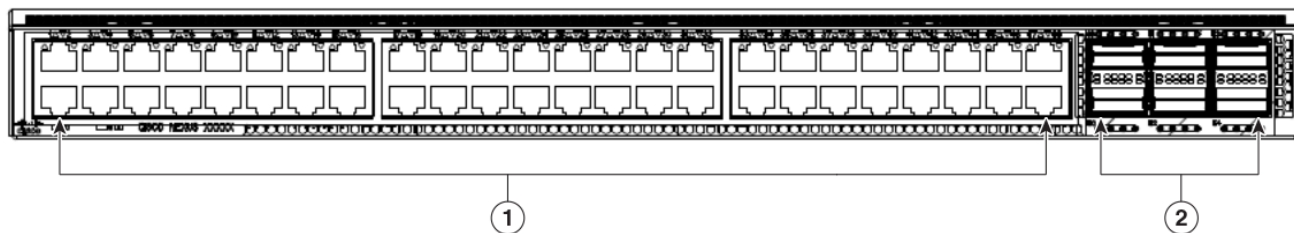

353643

1	48 Fixed 1/10GBASE-T SFP+ Ports
2	6 40G QSFP+ Ports

Figure 1-1 shows the fan side view of the Cisco Nexus 2348UPQ chassis, and Figure 1-3 shows the port side view of the chassis.

Figure 1-5 Port Side View of the Cisco Nexus 2348UPQ Chassis

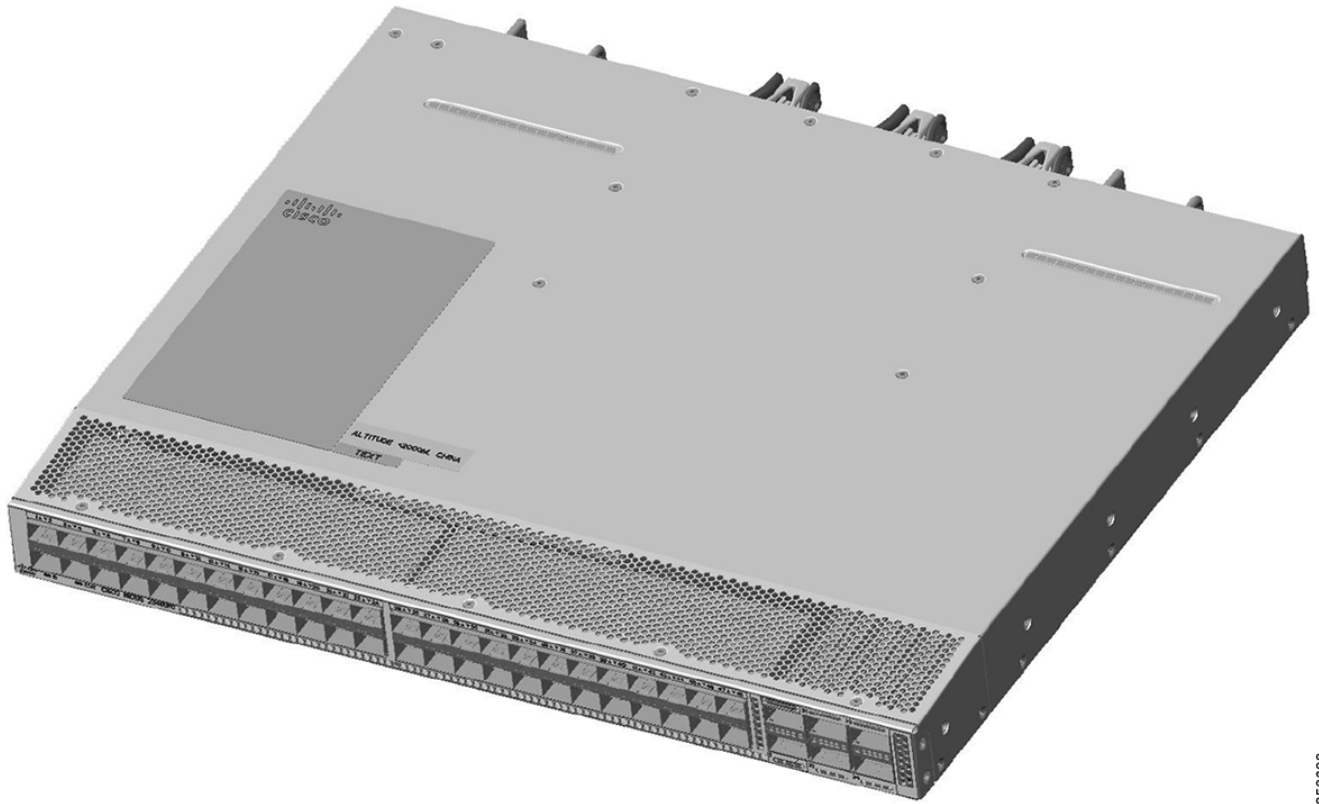

353698

Figure 1-6 Close up of Port Side View of the Cisco Nexus 2348UPQ Chassis

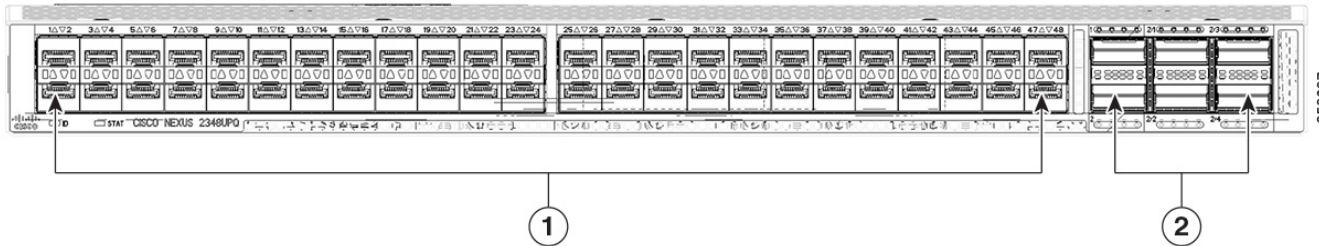

353697

1	48 Fixed 1/10G SFP+ Unified Capable Ports
2	6 40G QSFP+ Ports

Ports

The Cisco Nexus 2300 Series platform provides host-facing downlink ports, network-facing uplink ports, and service interface ports. The Cisco Nexus 2300 Series platform supports 48 1/10G host ports as well as up to 6 40G uplink ports towards the parent switch.

On the Cisco Nexus 2348TQ, the host ports provide connectivity to 1/10GBASE-T Ethernet. Dedicated uplink ports are color coded yellow (Network Interface Ports). Service Interface ports are color coded white.

On the Cisco Nexus 2348UPQ the host unified ports provide connectivity to 1/10G Ethernet and FCoE. Host ports with UP functionality are color coded orange (Host Interface Ports). Dedicated uplink ports are color coded yellow (Network Interface Ports). Service Interface ports are color coded white.

Power Supplies

The Cisco Nexus 2300 Series platform has two 1+1 redundant power supplies. The chassis is fully functional with one power supply, but you can install a second power supply for power redundancy. The power supply is hot swappable during operations. [Table 1-1](#) lists the power supplies that you can order with the Cisco Nexus 2300 Series platform.

Table 1-1 Power Supplies for the Cisco Nexus 2300 Platform Chassis

Power Supply	Part Number
AC power supply with port side exhaust airflow (Blue)	N2200-PAC-400W
AC power supply with port side intake airflow (Red)	N2200-PAC-400W-B
DC power supply with port side exhaust airflow (Blue)	N2200-PDC-400W
DC power supply with port side intake airflow (Red)	N2200-PDC-350W-B (for Cisco Nexus 2348UPQ only)

[Figure 1-7](#) shows an AC power supply with port-side exhaust airflow. [Figure 1-8](#) shows an AC power supply with port-side intake airflow. [Figure 1-9](#) shows a DC power supply with port-side exhaust airflow. [Figure 1-10](#) shows a DC power supply with port-side intake airflow.

Figure 1-7 AC Power Supply with Port-Side Exhaust Airflow for the Cisco Nexus 2300 Platform Chassis

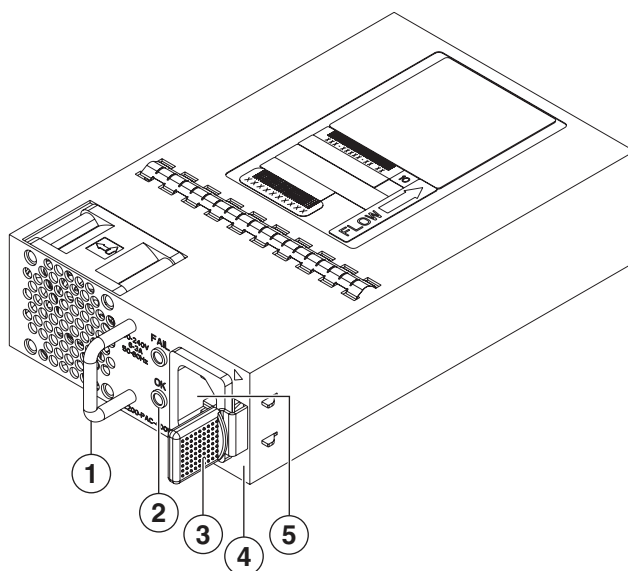

239843

1	Handle	4	No black stripe (port side exhaust airflow)
2	FAIL (top) and OK (bottom) LEDs	5	AC power receptacle
3	Ejector latch		

Figure 1-8 AC Power Supply with Port-Side Intake Airflow for the Cisco Nexus 2300 Platform Chassis

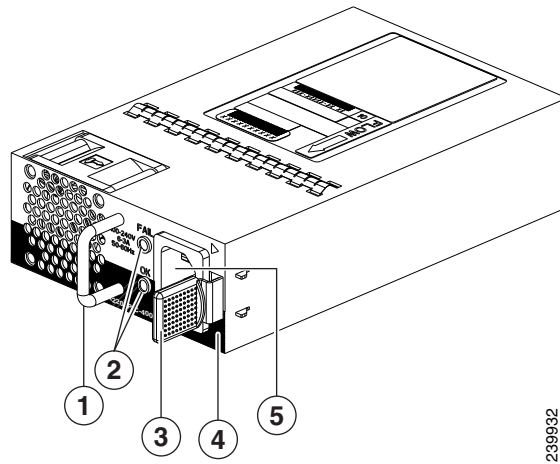

1	Handle	4	Black stripe (port side intake airflow)
2	FAIL (top) and OK (bottom) LEDs	5	AC power receptacle
3	Ejector latch		

Figure 1-9 DC Power Supply with Port-Side Exhaust Airflow for the Cisco Nexus 2300 Platform Chassis

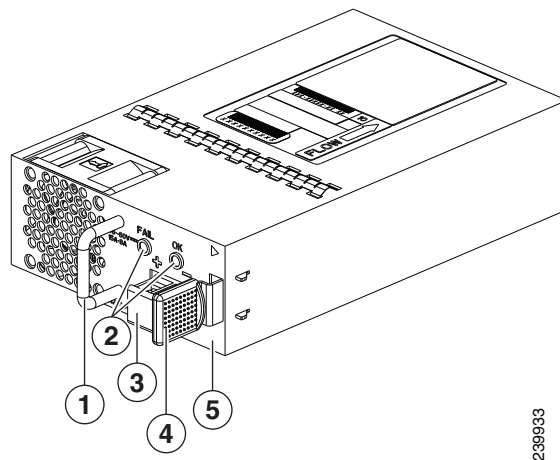

1	Handle	4	Ejector latch
2	FAIL (left) and OK (right) LEDs	5	No black stripe (port side exhaust airflow)
3	DC power receptacle		

Figure 1-10 DC Power Supply with Port-Side Intake Airflow for the Cisco Nexus 2300 Platform Chassis

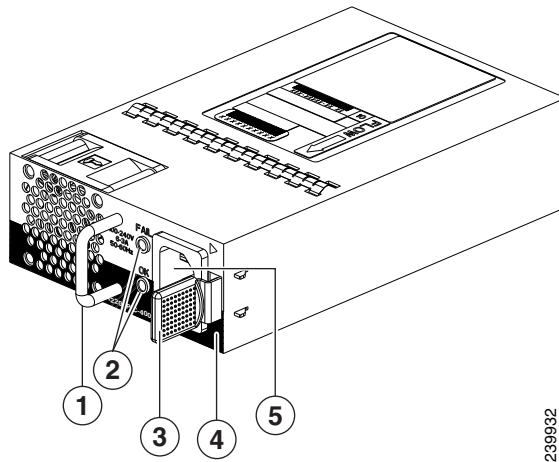

1	Handle	4	Black stripe (port side intake airflow)
2	FAIL (top) and OK (bottom) LEDs	5	AC power receptacle
3	Ejector latch		

You can order the Cisco Nexus 2300 Series platform with AC power supplies that have port-side exhaust or port-side intake airflow for cooling or DC power supplies that offer port-side exhaust and port-side intake airflow. The port-side intake airflow components have a black stripe on their front surface for easy visual identification. The port-side exhaust airflow components do not have a black stripe.



Note

Colored handles on each power supply clearly indicate the airflow direction.



Caution

Be sure that all of the power supply and fan modules in the same chassis have the same airflow direction and that the air intake for those modules is positioned on a cool aisle. If you install a module that uses a different direction of airflow than the other modules in the same switch, the switch can overheat and shut down. If you position a chassis with its modules taking cooling air from a warm aisle, the switch can over heat and shut down.

If one power supply is installed in the chassis, but the other power supply slot is empty, you should use a blank filler panel (part number N2200-P-BLNK) to cover the empty slot. [Figure 1-11](#) shows a blank power supply filler panel.

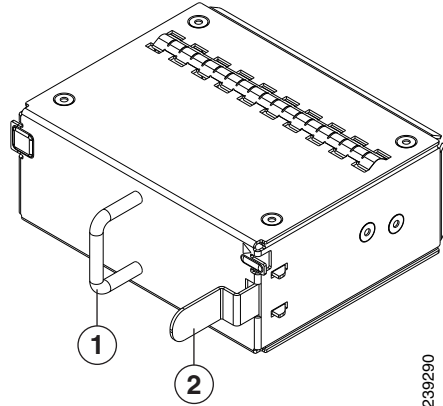
Figure 1-11 Blank Power Supply Filler Panel for the Cisco Nexus 2300 Platform Chassis

1	Handle	2	Ejector latch
----------	--------	----------	---------------

For power supply specifications, see the “[Power Specifications](#)” section on page B-1. To replace a power supply, see the “[Removing and Installing Power Supplies](#)” section on page 4-16.

Fans

The Cisco Nexus 2300 Series platform has three, hot-swappable independent fans with support for 2+1 redundancy. Depending on the arrangement of hot and cold aisles in your data center, you can order port-side exhaust airflow to position the fan side of the FEX chassis in a cold aisle or port-side intake airflow to position the back of the FEX chassis in a cold aisle. [Table 1-2](#) lists the part numbers for each of the fans that you can use with the Cisco Nexus 2300 Series chassis.



Note

Blue color coded tabs indicate port-side exhaust airflow. Red color coded tabs indicate port-side intake airflow.



Caution

Always make sure that all of the fan and power supply modules have the same direction of airflow and the same color designation for that airflow direction. The switch does not support having more than one direction of airflow with its modules.

Table 1-2 Fans for the Cisco Nexus 2300 Series Chassis

Description	Part Number
Port side exhaust airflow	N2K-2348UPQ-FAN (2348UPQ) N2K-2348TQ-FAN (2348TQ)
Port side intake airflow	N2K-2348UPQ-FAN-B (2348UPQ) N2K-2348TQ-FAN-B (2348TQ)

To replace a fan, see the “[Removing and Installing a Fan](#)” section on page 4-19.

Supported Transceivers and Cables

The Cisco Nexus 2300 Series platform supports a wide variety of 1, 10, and 40 Gigabit Ethernet connectivity options.

**Caution**

Currently, passive copper cables are not supported on the NIF/SIF ports. Also, 100M FX optics are not supported.

For the most current list of supported transceivers and optics, refer to the latest [Cisco Nexus 2000 Series Fabric Extenders Release Notes](#) at every release.

Cisco Nexus 2248TP-E

The Cisco Nexus 2248TP-E is a stackable 1 RU 17.2-inch (45 cm) deep FEX that supports 48 1000-TX host-facing (downlink) ports and 4 10-Gigabit SFP+ network-facing (uplink) ports. You can order it with port side exhaust or port side intake air cooling, and with AC or DC power supplies.

You can use this FEX with the Cisco Nexus 5000 Series switch. The Cisco Nexus 2248TP-E is managed and configured by the upstream switch. The FEX software ships with the Cisco Nexus 5000 Series switch software. The FEX downloads the software image from the switch the same way that a module would download it from the supervisor in a modular chassis.

This section includes the following topics:

- [Chassis, page 1-10](#)
- [Ports, page 1-12](#)
- [Power Supplies, page 1-12](#)
- [Fan Trays, page 1-15](#)
- [Supported Transceivers and Cables, page 1-17](#)

Chassis

The Cisco Nexus 2248TP-E FEX chassis has a height of 1.72 inches (4.37 cm), a width of 17.3 inches (43.94 cm), and a depth of 17.7 inches (44.96 cm). It weighs 17.7 pounds (8.0 kg). Its one-rack-unit (1 RU) form factor takes up relatively little space, making it easy to incorporate into rack designs. The FEX is mounted in a standard 19-inch (48.26 cm) rack. All switch ports at the rear of the unit are in close proximity to server ports, and all user-serviceable components are accessible from the fan side.

You can order it with port-side exhaust or port-side intake air cooling, and with AC or DC power supplies. If you are going to install the chassis with its fan side facing the cold aisle, you must order the chassis with port-side exhaust air flow. If you are going to install the chassis with its back end facing the cold aisle, you must order the chassis with port-side intake airflow.

**Caution**

Always make sure that all of the fan tray and power supply modules have the same direction of airflow and the same color designation for that airflow direction. The switch does not support having more than one direction of airflow with its modules.

Figure 1-12 shows the location of the components found on the fan side of the chassis, and Figure 1-13 shows the location of components found on the rear of the chassis. For information on what the chassis and component LEDs indicate, see Table E-1 on page E-2.

Figure 1-12 Fan side view of the Cisco Nexus 2248TP-E Chassis

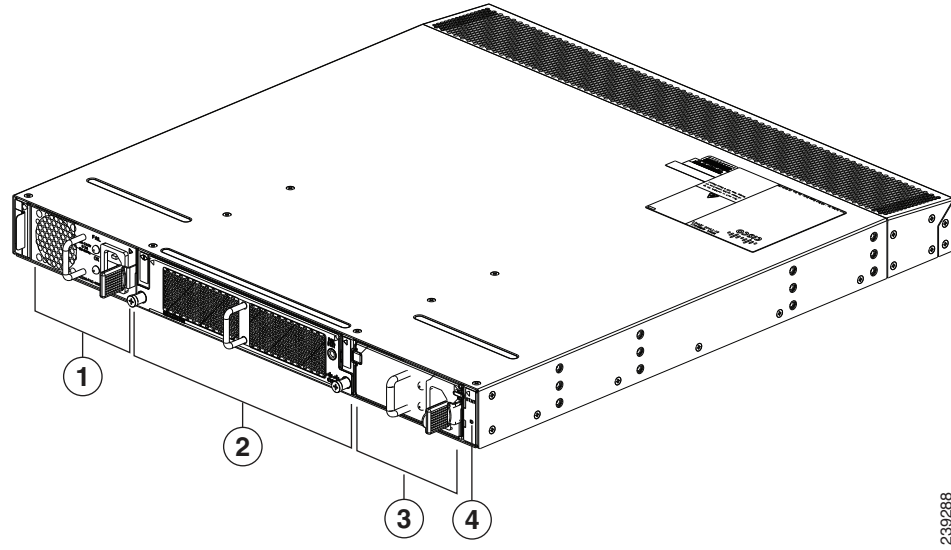

1	Power supply	3	Power supply (blank shown)
2	Fan tray	4	Status (top) and ID (bottom) LEDs

Figure 1-13 Rear View of the Cisco Nexus 2248TP-E Chassis

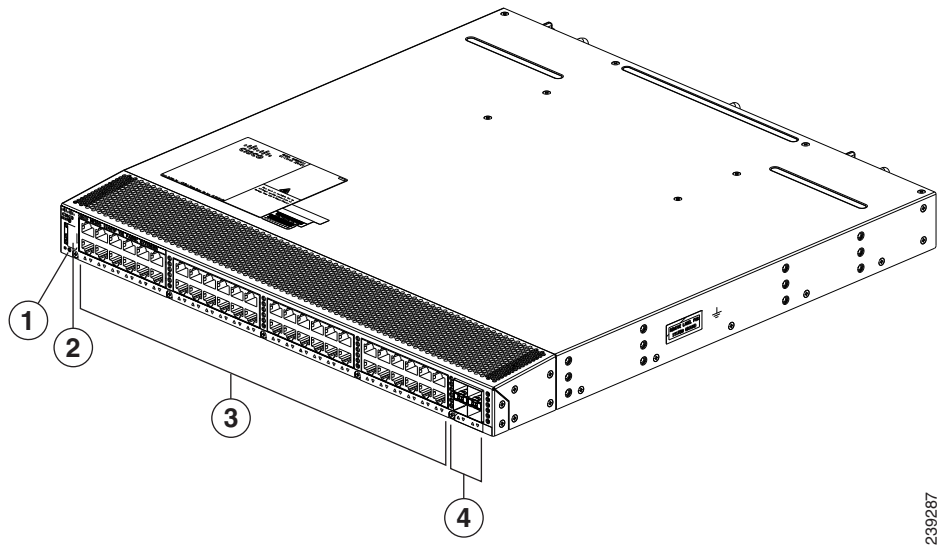

1	Status (top) and ID (bottom) LEDs	3	100/1000 downlink ports (48)
2	HDMI port	4	SFP+ uplink ports (four)

Ports

The Cisco Nexus 2248TP-E FEX supports a total of 48 100/1000BASE-T ports and four 10-Gigabit Ethernet uplinks (SFP+). The Cisco Nexus 2300 series provides three types of ports: ports for end-host attachment (host interfaces), uplink ports (fabric interfaces) and flexible ports (to be configured as either host or fabric interfaces). Fabric interfaces are for connectivity to the upstream parent Cisco Nexus switch and are indicated by yellow color. Flexible interfaces can be used for connectivity to the upstream parent or towards the host, and are indicated by white color.

Power Supplies

The Cisco Nexus 2248TP-E FEX chassis has two bays for fan side AC or DC power supplies. This chassis is fully functional with one power supply, but you can install a second power supply for power redundancy. The power supply is hot swappable during operations.

[Table 1-3](#) lists the power supplies that you can order with the Cisco Nexus 2248TP-E FEX.

Table 1-3 Power Supplies for the Cisco Nexus 2200 and Cisco Nexus 2300 Platform Chassis

Power Supply	Part Number
AC power supply with port-side exhaust airflow	N2200-PAC-400W
AC power supply with port-side intake airflow	N2200-PAC-400W-B
DC power supply with port-side exhaust airflow	N2200-PDC-400W
DC power supply with port-side intake airflow	N2200-PDC-350W-B



Caution

Always make sure that all of the fan tray and power supply modules have the same direction of airflow and the same color designation for that airflow direction. The switch does not support having more than one direction of airflow with its modules.

[Figure 1-14](#) shows an AC power supply with port-side exhaust airflow. [Figure 1-15](#) shows an AC power supply with port-side intake airflow. [Figure 1-16](#) shows a DC power supply with port-side exhaust airflow. [Figure 1-17](#) shows a DC power supply with port-side intake airflow.

Figure 1-14 AC Power Supply with Port-Side exhaust Airflow for the Cisco Nexus 2200 and Cisco Nexus 2300 Platform Chassis

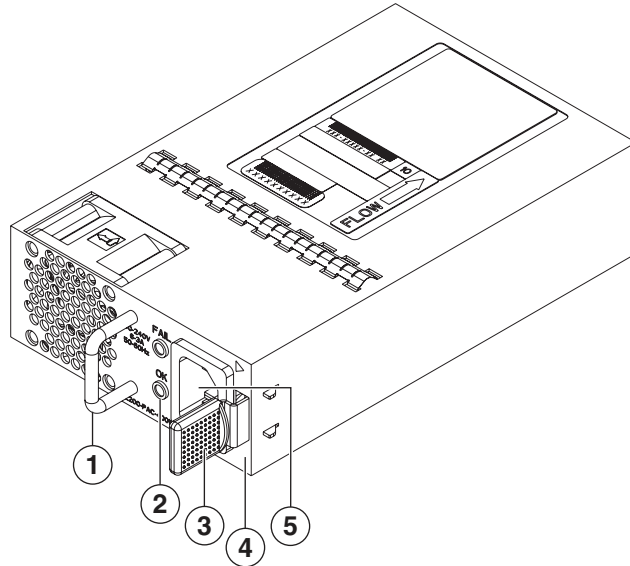

1	Handle	4	No black stripe (port-side exhaust airflow)
2	FAIL (top) and OK (bottom) LEDs	5	AC power receptacle
3	Ejector latch		

Figure 1-15 AC Power Supply with Port-Side Intake Airflow for the Cisco Nexus 2200 and Cisco Nexus 2300 Platform Chassis

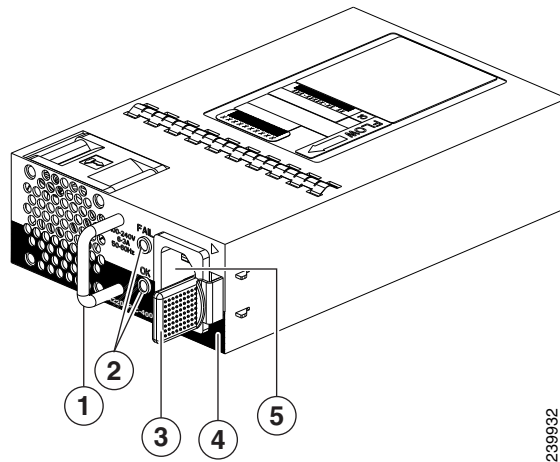

1	Handle	4	Black stripe (port side intake airflow)
2	FAIL (top) and OK (bottom) LEDs	5	AC power receptacle
3	Ejector latch		

Figure 1-16 DC Power Supply with Port-Side Exhaust Airflow for the Cisco Nexus 2200 and Cisco Nexus 2300 Platform Chassis

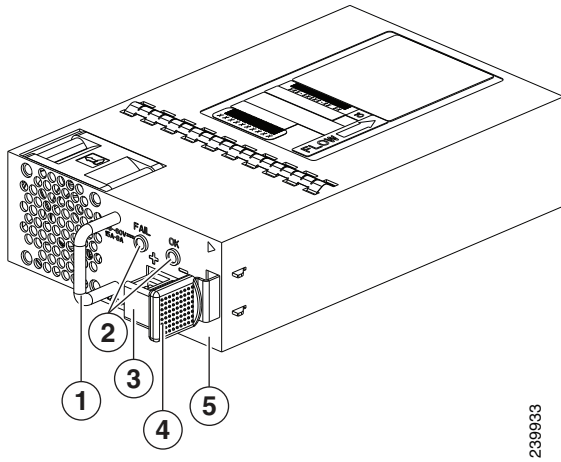

1	Handle	4	Ejector latch
2	FAIL (left) and OK (right) LEDs	5	No black stripe (port-side exhaust airflow)
3	DC power receptacle		

Figure 1-17 DC Power Supply with Port-Side Intake Airflow for the Cisco Nexus 2200 and Cisco Nexus 2300 Platform Chassis

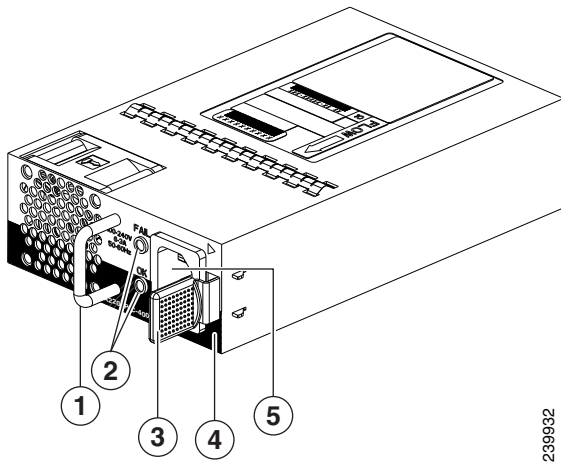

1	Handle	4	Black stripe (port-side intake airflow)
2	FAIL (top) and OK (bottom) LEDs	5	AC power receptacle
3	Ejector latch		

You can order the Cisco Nexus 2248TP-E FEX with AC power supplies that have port side exhaust or port side intake airflow for cooling or DC power supplies that offer port side exhaust airflow. The port side intake airflow components have a black stripe on their fan side surface for easy visual identification. The port side exhaust airflow components do not have a black stripe.

Caution

Be sure that all of the power supply and fan tray modules in the same chassis have the same airflow direction and that the air intake for those modules is positioned on a cool aisle. If you install a module that uses a different direction of airflow from the other modules in your system, you will see an error message. If you position a chassis with its modules taking cooling air from a warm aisle, the switch can over heat and shut down.

If one power supply is installed in the chassis, but the other power supply slot is empty, you should use a blank filler panel (part number N2200-P-BLNK) to cover the empty slot. [Figure 1-18](#) shows a blank power supply filler panel.

Figure 1-18 Blank Power Supply Filler Panel for the Cisco Nexus 2200 and Cisco Nexus 2300 Platform Chassis

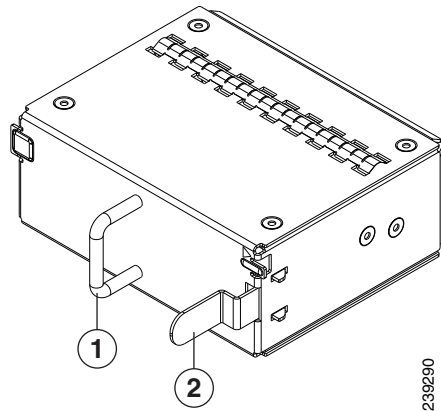

1	Handle	2	Ejector latch
----------	--------	----------	---------------

For power supply specifications, see the “[Power Specifications](#)” section on page B-1. To replace a power supply, see the “[Removing and Installing Power Supplies](#)” section on page 4-16. For LED descriptions, see [Table E-1](#) on page E-2.

Fan Trays

The Cisco Nexus 2248TP-E FEX has one fan tray that is hot swappable during operations. Depending on the arrangement of hot and cold aisles in your data center, you can order port-side exhaust airflow to position the fan side of the FEX chassis in a cold aisle or port-side intake airflow to position the back of the FEX chassis in a cold aisle. [Table 1-4](#) lists the part numbers for each of the fan trays that you can use with the Cisco Nexus 2248TP-E chassis.

Table 1-4 Fan Trays for the Cisco Nexus 2248TP-E FEXs

Description	Part Number
port-side exhaust airflow	N2K-C2248TP-FAN
port-side intake airflow	N2K-C2248TP-FAN-B

Caution

Always make sure that all of the fan tray and power supply modules have the same direction of airflow and the same color designation for that airflow direction. The switch does not support having more than one direction of airflow with its modules.

Figure 1-19 shows a port-side exhaust airflow fan tray, and Figure 1-20 shows a port-side intake airflow fan tray.

Figure 1-19 Port-Side Exhaust Airflow Fan Tray Components for the Cisco Nexus 2248TP-E and 2224TP FEXs

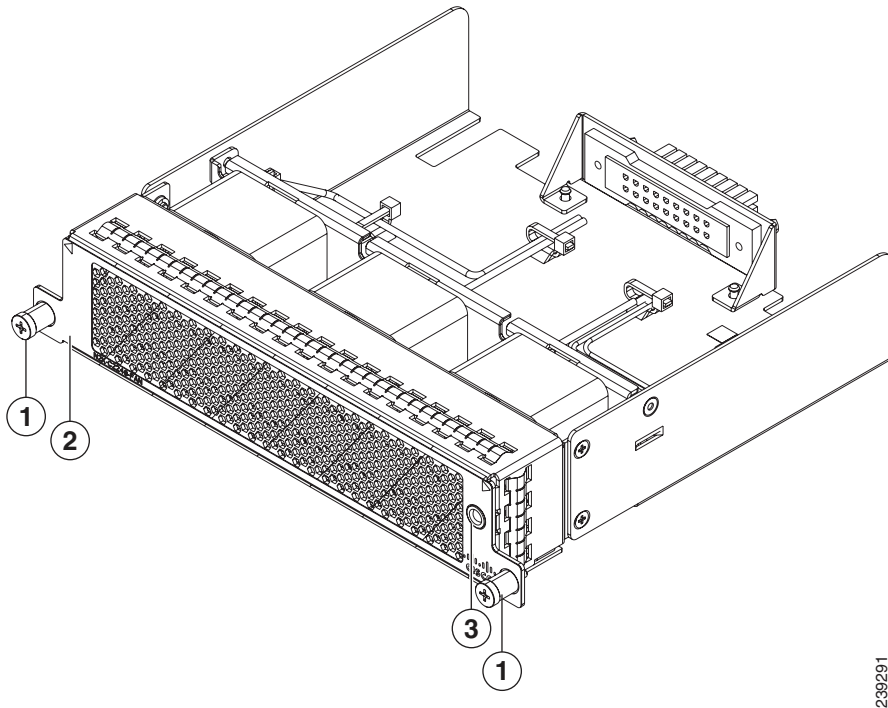

1	Captive screws (2)	3	Status LED
2	No black stripe indicates port-side exhaust airflow		

239291

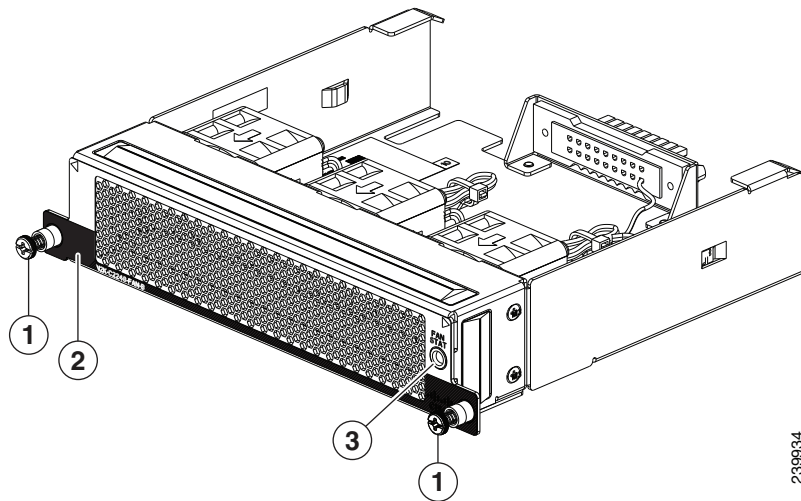
Figure 1-20 Port-Side Intake Airflow Fan Tray for the Cisco Nexus 2248TP-E FEX

1	Captive screws (2)	3	Status LED
2	Black stripe indicates port-side intake airflow		

To replace a fan tray, see the “[Removing and Installing the Fan Tray](#)” section on page 4-21. For LED descriptions, see [Table E-1](#) on page E-2.

Supported Transceivers and Cables

The Cisco Nexus 2248TP-E FEX supports SFP+ Ethernet transceivers. The enhanced Small-Form-Factor Pluggable (SFP+) 10-Gigabit Ethernet transceiver is a bidirectional device with a transmitter and receiver. It has a 20-pin connector on the electrical interface and duplex LC connector on the optical interface. Currently, the Cisco Nexus 2248TP-E FEX supports the short-range SFP and long-range SFP transceiver. Copper interface cables are available for use with the 10-Gigabit Ethernet SFP+ transceiver. For details see, the [Cisco Nexus 2000 Series Fabric Extenders Release Notes](#).

Cisco Nexus 2248TP

The Cisco Nexus 2248TP is a stackable 1 RU 17.2-inch (45 cm) deep FEX that supports 48 1000-TX host-facing (downlink) ports and 4 10-Gigabit SFP+ network-facing (uplink) ports. You can order it with port side exhaust or port side intake air cooling, and with AC or DC power supplies.

You can use this FEX with the Cisco Nexus 5000 Series switch. The Cisco Nexus 2248TP is managed and configured by the upstream switch. The FEX software ships with the Cisco Nexus 5000 Series switch software. The FEX downloads the software image from the switch the same way that a module would download it from the supervisor in a modular chassis.

This section includes the following topics:

- [Chassis, page 1-18](#)
- [Ports, page 1-19](#)

- [Power Supplies, page 1-19](#)
- [Fan Tray, page 1-22](#)
- [Supported Transceivers and Cables, page 1-24](#)

Chassis

The Cisco Nexus 2248TP FEX chassis has a height of 1.72 inches (4.37 cm), a width of 17.3 inches (43.94 cm), and a depth of 17.7 inches (44.96 cm). It weighs 17.7 pounds (8.0 kg). Its one-rack-unit (1 RU) form factor takes up relatively little space, making it easy to incorporate into rack designs. The FEX is mounted in a standard 19-inch (48.26 cm) rack. All switch ports at the rear of the unit are in close proximity to server ports, and all user-serviceable components are accessible from the fan side.

You can order it with port-side exhaust or port-side intake air cooling (do not mix air directions for a chassis), and with AC or DC power supplies. If you are going to install the chassis with its fan side facing the cold aisle, you must order the chassis with port-side exhaust airflow. If you are going to install the chassis with its back end facing the cold aisle, you must order the chassis with port-side intake airflow.

[Figure 1-21](#) shows the location of the components found on the fan side of the chassis, and [Figure 1-22](#) shows the location of components found on the rear of the chassis. For information on what the chassis and component LEDs indicate, see [Table E-1 on page E-2](#).

Figure 1-21 Fan side view of the Cisco Nexus 2248TP Chassis

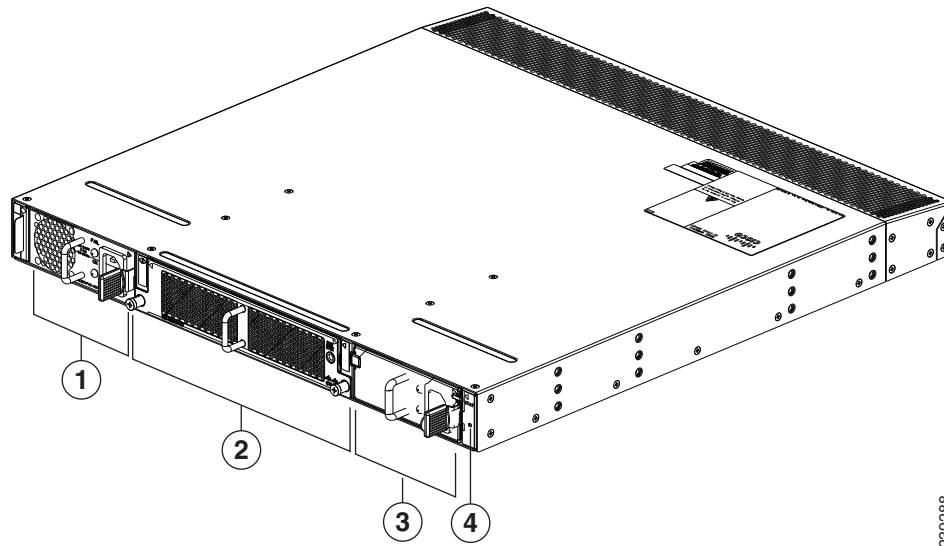

1	Power supply	3	Power supply (blank shown)
2	Fan tray	4	Status (top) and ID (bottom) LEDs

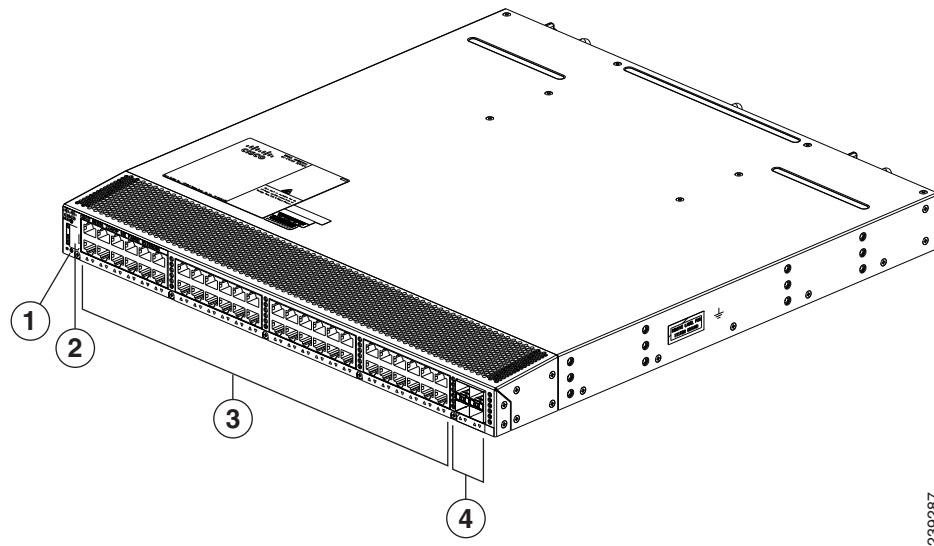
Figure 1-22 Rear View of the Cisco Nexus 2248TP Chassis

1	Status (top) and ID (bottom) LEDs	3	100/1000 downlink ports (48)
2	HDMI port	4	SFP+ uplink ports (four)

Ports

The Cisco Nexus 2248TP FEX supports a total of 48 100/1000BASE-T ports and four, 10-Gigabit Ethernet uplinks (SFP+). It provides two types of ports: host-facing downlink ports and network-facing uplink ports. Uplink ports are differentiated with yellow for connectivity to the upstream parent Cisco Nexus 5000 Series switch.

Power Supplies

The Cisco Nexus 2248TP FEX chassis has two bays for fan side AC or DC power supplies. This chassis is fully functional with one power supply, but you can install a second power supply for power redundancy. The power supply is hot swappable during operations.

[Table 1-5](#) lists the power supplies that you can order with the Cisco Nexus 2248TP FEX.

Table 1-5 Power Supplies for the Cisco Nexus 2200 and Cisco Nexus 2300 Platform Chassis

Power Supply	Part Number
AC power supply with port-side exhaust airflow	N2200-PAC-400W
AC power supply with port-side intake airflow	N2200-PAC-400W-B
DC power supply with port-side exhaust airflow	N2200-PDC-400W
DC power supply with port-side intake airflow	N2200-PDC-350W-B

**Caution**

Always make sure that all of the fan tray and power supply modules have the same direction of airflow and the same color designation for that airflow direction. The switch does not support having more than one direction of airflow with its modules.

Figure 1-23 shows an AC power supply with port-side exhaust airflow. Figure 1-24 shows an AC power supply with port-side intake airflow. Figure 1-25 shows a DC power supply with port-side exhaust airflow.

Figure 1-23 AC Power Supply with Port-Side Exhaust Airflow for the Cisco Nexus 2200 and Cisco Nexus 2300 Platform Chassis

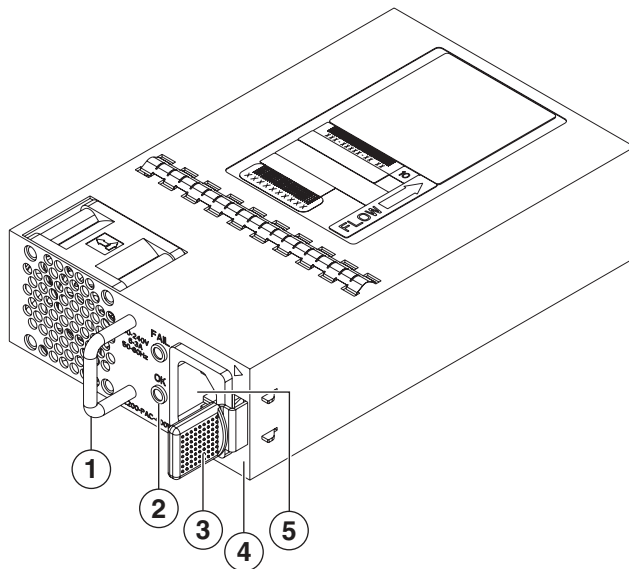

1	Handle	4	No black stripe (port-side exhaust airflow)
2	OK (top) and FAULT (bottom) LEDs	5	AC power receptacle
3	Ejector latch		

Figure 1-24 AC Power Supply with Port-Side Intake Airflow for the Cisco Nexus 2200 and Cisco Nexus 2300 Platform Chassis

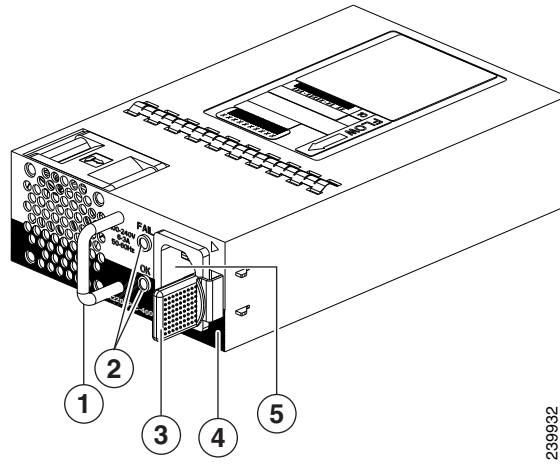

1	Handle	4	Black stripe (port-side intake airflow)
2	FAULT (top) and OK (bottom) LEDs	5	AC power receptacle
3	Ejector latch		

Figure 1-25 DC Power Supply with Port-Side Exhaust Airflow for the Cisco Nexus 2200 and Cisco Nexus 2300 Platform Chassis

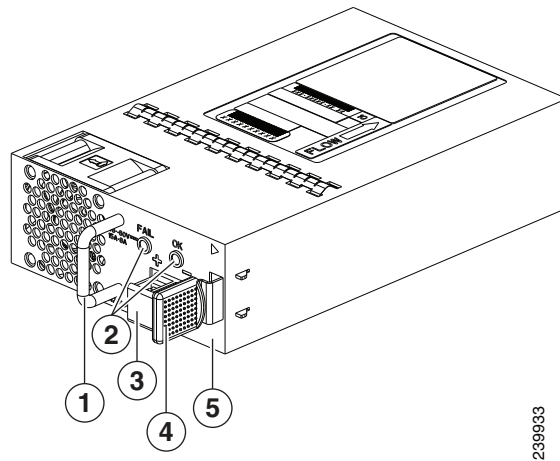

1	Handle	4	Ejector latch
2	FAULT (top) and OK (bottom) LEDs	5	No black stripe (port-side exhaust airflow)
3	DC power receptacle		

You can order the Cisco Nexus 2248TP FEX with AC power supplies that have port-side exhaust or port-side intake airflow for cooling or DC power supplies that offer port-side exhaust airflow. The port-side intake airflow components have a black stripe on their fan side surface for easy visual identification. The port-side exhaust airflow components do not have a black stripe.

**Caution**

Be sure that all of the power supply and fan tray modules in the same chassis have the same airflow direction and that the air intake for those modules is positioned on a cool aisle. If you install a module that uses a different direction of airflow from the other modules in your system, you will see an error message. If you position a chassis with its modules taking cooling air from a warm aisle, the switch can over heat and shut down.

If one power supply is installed in the chassis, but the other power supply slot is empty, you should use a blank filler panel (part number N2200-P-BLNK) to cover the empty slot. [Figure 1-26](#) shows a blank power supply filler panel.

Figure 1-26 Blank Power Supply Filler Panel for the Cisco Nexus 2200 and Cisco Nexus 2300 Platform Chassis

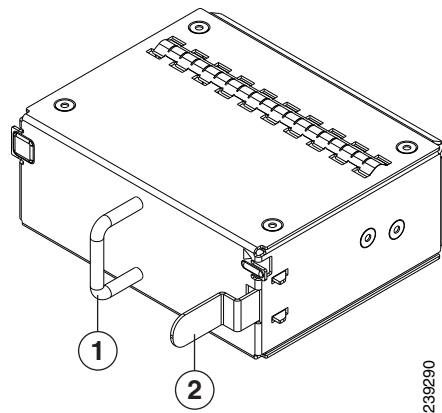

1	Handle	2	Ejector latch
----------	--------	----------	---------------

For power supply specifications, see the “[Power Specifications](#)” section on page B-1. To replace a power supply, see the “[Removing and Installing Power Supplies](#)” section on page 4-16. For LED descriptions, see [Table E-1](#) on page E-2.

Fan Tray

The Cisco Nexus 2248TP (and 2224TP) FEX has one fan tray that is hot swappable during operations. Depending on the arrangement of hot and cold aisles in your data center, you can order port-side exhaust airflow to position the fan side of the FEX chassis in a cold aisle or port-side intake airflow to position the back of the FEX chassis in a cold aisle. [Table 1-6](#) lists the part numbers for each of the fan trays that you can use with the Cisco Nexus 2248TP and 2224TP chassis.

Table 1-6 Fan Trays for the Cisco Nexus 2248TP and 2224TP FEXs

Description	Part Number
Port-side exhaust airflow	N2K-C2248-FAN
Port-side intake airflow	N2K-C2248-FAN-B

**Caution**

Always make sure that all of the fan tray and power supply modules have the same direction of airflow and the same color designation for that airflow direction. The switch does not support having more than one direction of airflow with its modules.

Figure 1-27 shows a port-side exhaust airflow fan tray, and Figure 1-28 shows a port side intake airflow fan tray.

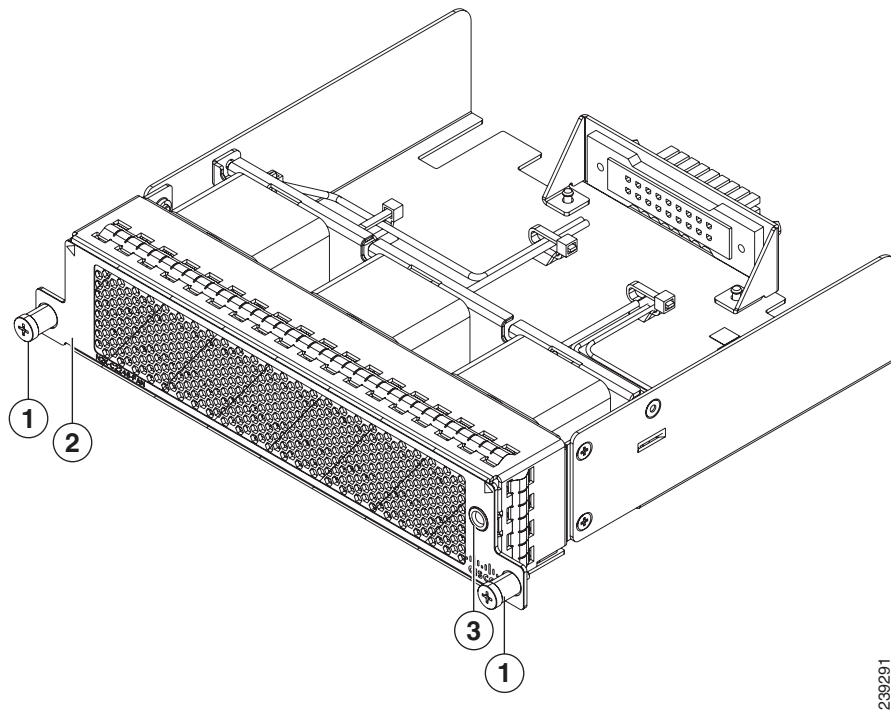
Figure 1-27 Port-Side Exhaust Airflow Fan Tray Components for the Cisco Nexus 2248TP and 2224TP FEXs

1	Captive screws (2)	3	Status LED
2	No black stripe indicates port-side exhaust airflow		

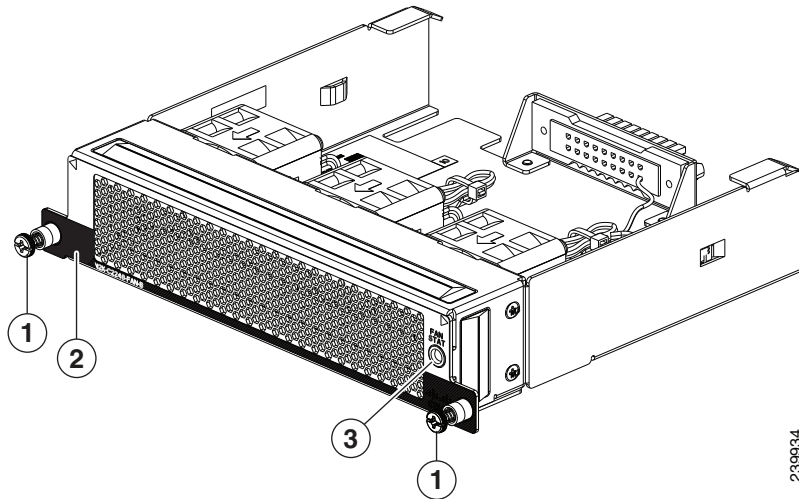
Figure 1-28 Port-Side Intake Airflow Fan Tray for the Cisco Nexus 2248TP and 224TP FEXs

1	Captive screws (2)	3	Status LED
2	Black stripe indicates port-side intake airflow		

To replace a fan tray, see the “[Removing and Installing the Fan Tray](#)” section on page 4-21. For LED descriptions, see [Table E-1](#) on page E-2.

Supported Transceivers and Cables

The Cisco Nexus 2248TP FEX supports SFP+ Ethernet transceivers. The enhanced Small-Form-Factor Pluggable (SFP+) 10-Gigabit Ethernet transceiver is a bidirectional device with a transmitter and receiver. It has a 20-pin connector on the electrical interface and duplex LC connector on the optical interface. Currently, the Cisco Nexus 2000 Series FEX supports the short-range SFP and long-range SFP transceiver. Copper interface cables are available for use with the 10-Gigabit Ethernet SFP+ transceiver. For an updated list of supported transceivers and optics, please see the [Cisco Nexus 2000 Series Fabric Extenders Release Notes](#).

Cisco Nexus 2248PQ

The Cisco Nexus 2248PQ is a stackable 1 RU 17.2 inch (45 cm) deep FEX that supports high-density 10-Gigabit Ethernet environments and has 48 1/10-Gigabit SFP+ host interfaces and 4 QSFP+ (16 10-Gigabit) on network interfaces. QSFP+ connectivity simplifies cabling while lowering power and solution costs. You can order it with port side exhaust or port side intake air cooling, which makes this FEX compatible with hot-aisle, cold aisle data center designs.

You can use this FEX with the Cisco Nexus 5500 Series switch and the Cisco Nexus 6004 parent switch (The supported software is Cisco Nexus OS Release 6.0(2)N1(1)). The Cisco Nexus 2248PQ is managed and configured by the upstream switch. The FEX software ships with the Cisco Nexus 5500 Series switch software. The FEX downloads the software image from the switch the same way that a module would download it from the supervisor in a modular chassis.

This section includes the following topics:

- [Chassis, page 1-25](#)
- [Ports, page 1-25](#)
- [Power Supplies, page 1-25](#)
- [Fan Trays, page 1-26](#)
- [Supported SFP+ Transceivers, page 1-27](#)

Chassis

The Cisco Nexus 2248PQ FEX chassis has a height of 1.72 inches (4.37 cm), a width of 17.3 inches (43.94 cm), and a depth of 17.7 inches (44.96 cm). It weighs 17.5 pounds (8.0 kg). Its one-rack-unit (1 RU) form factor takes up relatively little space, making it easy to incorporate into rack designs. The FEX is mounted in a standard 19-inch (48.26 cm) rack. All of the switch ports at the rear of the chassis are in close proximity to server ports, and all user-serviceable components are accessible from the fan side.

You can order port-side exhaust airflow or port-side intake airflow for cooling. If you are going to install the chassis with its fan side facing the cold aisle, you must order the chassis with port-side exhaust air flow. If you are going to install the chassis with its back end facing the cold aisle, you must order the chassis with port-side intake airflow.

Ports

The Cisco Nexus 2248PQ FEX supports a total of 48 1/10-Gigabit Ethernet/Fibre Channel over Ethernet (FCoE) ports (SFP+) and 4 QSFP+ (16 10-Gigabit) fabric ports. The Cisco Nexus 2248PQ provides two types of ports: ports for end-host attachments and uplink ports. Uplink ports are differentiated with yellow for connectivity to the upstream parent Cisco Nexus 5000 Series switch.

The Cisco Nexus 2248PQ 10GE Fabric Extender supports FCoE and Data Center Bridging (DCB) which increases the reliability, efficiency, and scalability of Ethernet networks by allowing the switches to support multiple traffic classes over a lossless Ethernet fabric, enabling consolidation of LAN, SAN, and cluster environments.

Power Supplies

The Cisco Nexus 2248PQ FEX chassis has two bays for fan side AC or DC power supplies. This chassis is fully functional with one power supply, but you can install a second power supply for power redundancy. The power supply is hot swappable during operations.

[Table 1-7](#) lists the power supplies that you can order with the Cisco Nexus 2248PQ FEX.

Table 1-7 Power Supplies for the Cisco Nexus 2200 and Cisco Nexus 2300 Platform Chassis

Power Supply	Part Number
AC power supply with port-side exhaust airflow	N2200-PAC-400W
AC power supply with port-side intake airflow	N2200-PAC-400W-B

Table 1-7 Power Supplies for the Cisco Nexus 2200 and Cisco Nexus 2300 Platform Chassis

Power Supply	Part Number
DC power supply with port-side exhaust airflow	N2200-PDC-400W
DC power supply with port-side intake airflow	N2200-PDC-350W-B

[Figure 1-23 on page 1-20](#) shows an AC power supply with port-side exhaust airflow. [Figure 1-24 on page 1-21](#) shows an AC power supply with port-side intake airflow. [Figure 1-25 on page 1-21](#) shows a DC power supply with port-side exhaust airflow.

You can order the Cisco Nexus 2248PQ FEX with AC power supplies that have port-side exhaust or port-side intake airflow for cooling or DC power supplies that have port-side exhaust airflow. The port-side intake airflow components have a black stripe on their fan side surface for easy visual identification. The port-side exhaust airflow components do not have a black stripe.

[Table 1-5 on page 1-19](#) lists the power supplies that you can order with the Cisco Nexus 2200 and Cisco Nexus 2300 Platform FEXs.

**Caution**

Be sure that all of the power supply and fan tray modules in the same chassis have the same airflow direction and that the air intake for those modules is positioned on a cool aisle. If you install a module that uses a different direction of airflow from the other modules in your system, you will see an error message. If you position a chassis with its modules taking cooling air from a warm aisle, the switch can over heat and shut down.

If one power supply is installed in the chassis, but the other power supply slot is empty, you should use a blank filler panel (N2200-P-BLNK) to cover the empty slot. [Figure 1-26 on page 1-22](#) shows a blank power supply filler panel.

For power supply specifications, see “[Power Specifications](#)”. To replace a power supply, see the “[Removing and Installing Power Supplies](#)” section on page 4-16.

**Caution**

Hot swapping of different direction fans and power supplies is not supported.

Fan Trays

The Cisco Nexus 2248PQ FEX has one fan tray that is hot swappable during operations. Depending on whether there is a cold aisle in the fan side or port side of the chassis, you can order port side exhaust airflow or port side intake airflow for the fan tray and the power supplies in the same chassis. [Table 1-8](#) lists the part numbers for each of the fan trays that you can use with this chassis.

Table 1-8 Fan Trays for the Cisco Nexus 2248PQ FEX

Description	Part Number
Port-side exhaust airflow (blue color coded fans)	N2K-C2248PQ-FAN
Port-side intake airflow (red color coded fans)	N2K-C2248PQ-FAN-B

**Caution**

Always make sure that all of the fan tray and power supply modules have the same direction of airflow and the same color designation for that airflow direction. The switch does not support having more than one direction of airflow with its modules.

To replace a fan tray, see the “[Removing and Installing the Fan Tray](#)” section on page 4-21. For LED descriptions, see “[Chassis and Module LEDs for the Cisco Nexus Fabric Extenders](#)”.

Supported SFP+ Transceivers

The Cisco Nexus 2248PQ Series FEX supports SFP+ Ethernet transceivers. The enhanced Small-Form-Factor Pluggable (SFP+) 10-Gigabit Ethernet transceiver is a bidirectional device with a transmitter and receiver. It has a 20-pin connector on the electrical interface and duplex LC connector on the optical interface. Currently, the Cisco Nexus 2000 Series FEX supports the short-range SFP and long-range SFP transceiver. Copper interface cables are available for use with the 10-Gigabit Ethernet SFP+ transceiver. For an updated list of supported transceivers and optics, please see the [Cisco Nexus 2000 Series Fabric Extenders Release Notes](#).

Cisco Nexus 2232TM-10GE, Cisco Nexus N2K-C2232TM-E-10GE

The Cisco Nexus 2232TM-10GE is a stackable 1 RU 17.72 inch (45 cm) deep FEX that supports 32 1/10-Gigabit Base-T host-facing (downlink) ports and 8 10-Gigabit Ethernet (SFP+) network-facing (uplink) ports through an uplink module.

You can use this FEX with the Cisco Nexus 5000 Series switch. The Cisco Nexus 2232TM-10GE is managed and configured by the upstream switch. The FEX software ships with the Cisco Nexus 5000 Series switch software. The FEX downloads the software image from the switch the same way that a module would download it from the supervisor in a modular chassis.

You can use the Cisco Nexus 2232TM-E-10GE with the Cisco Nexus 5000 Series switch starting in the NX-OS 5.2(1)N1(1) release and beyond

This section includes the following topics:

- [Chassis, page 1-27](#)
- [Ports, page 1-29](#)
- [Power Supplies, page 1-30](#)
- [Fan Trays, page 1-31](#)
- [Supported Transceivers and Cables, page 1-32](#)

Chassis

The Cisco Nexus 2232TM FEX chassis has a height of 1.72 inches (4.37 cm), a width of 17.3 inches (43.94 cm), and a depth of 17.7 inches (44.96 cm). It weighs 18.5 pounds (8.4 kg). Its one-rack-unit (1 RU) form factor takes up relatively little space, making it easy to incorporate into rack designs. The FEX is mounted in a standard 19-inch (48.26 cm) rack and supports vertical orientation. All of the switch ports at the rear of the chassis are in close proximity to server ports, and all user-serviceable components are accessible from the fan side.

You can order it with port-side exhaust or port-side intake air cooling, and AC or DC power supplies. If you are going to install the chassis with its fan side facing the cold aisle, you must order the chassis with port-side exhaust airflow. If you are going to install the chassis with its back end facing the cold aisle, you must order the chassis with port-side intake airflow.

Figure 1-29 shows the location of the components on the fan of the chassis, and Figure 1-30 shows the location of components on the rear of the chassis. For information on what the chassis and component LEDs indicate, see “Chassis and Module LEDs for the Cisco Nexus Fabric Extenders”.

Figure 1-29 Fan side view of the Cisco Nexus 2232TM-10GE Chassis

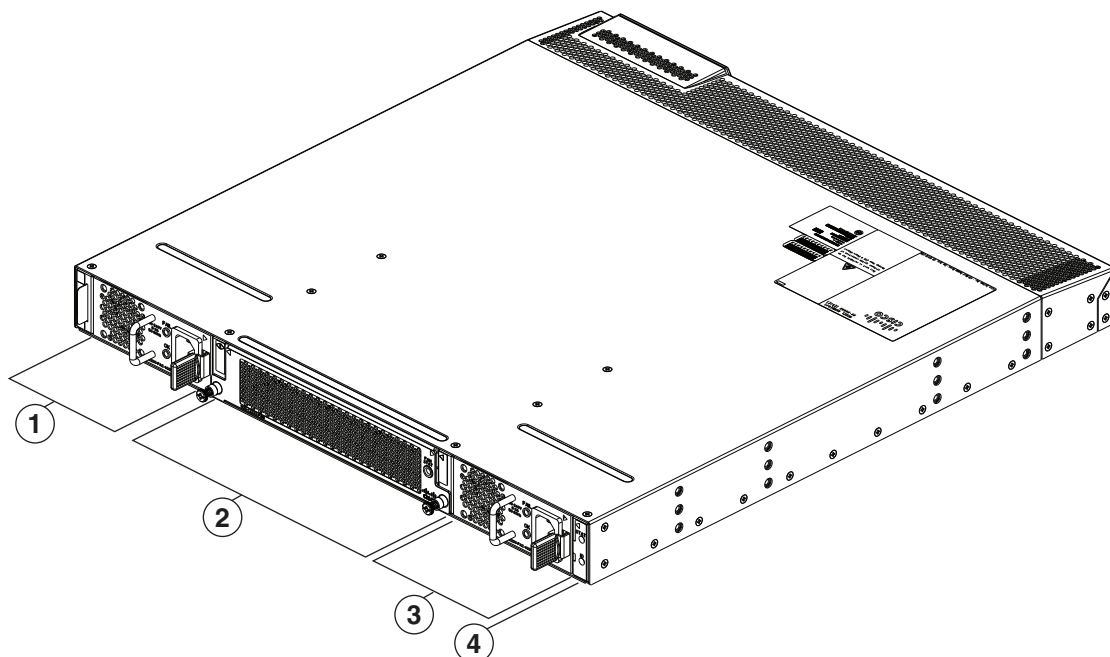

330055

1	Power supply	3	Power supply
2	Fan tray	4	Status (top) and ID (bottom) LEDs

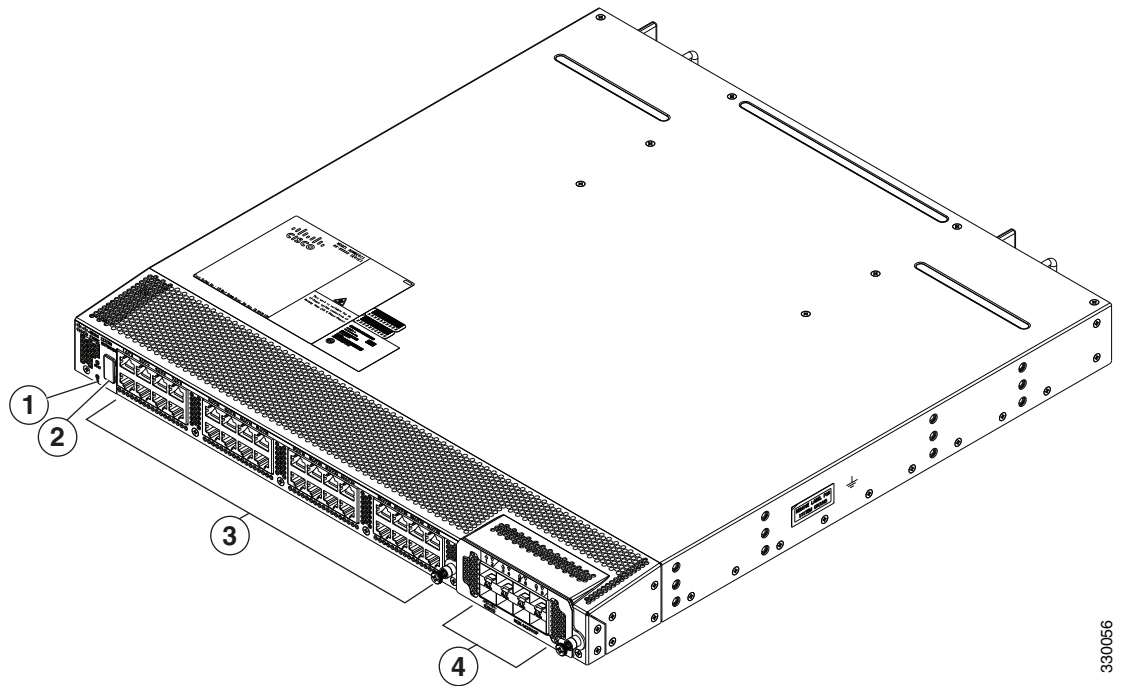
Figure 1-30 Rear View of the Cisco Nexus 2232TM Chassis

330056

1	Status and ID LEDs	3	10-Gigabit Base-T host-facing (downlink) ports (32)
2	HDMI port	4	10-Gigabit SFP+ ports (8)

Ports

The Cisco Nexus 2232TM FEX supports a total of 32 10-Gigabit Ethernet ports (SFP+) and 8 10-Gigabit Ethernet/FCoE uplinks (SFP+). SFP transceivers can also be plugged into the SFP+ cages to allow a 1-Gigabit downlink. The Cisco Nexus 2232TM-10GE provides two types of ports: ports for end-host attachment and uplink ports. Uplink ports, which are colored yellow, connect to the upstream parent Cisco Nexus 5000 Series switch.

The Cisco Nexus 2232TM-10GE supports Data Center Bridging (DCB) which increases the reliability, efficiency, and scalability of Ethernet networks by allowing the switches to support multiple traffic classes over a lossless Ethernet fabric. These features allow the switches to support multiple traffic classes over a lossless Ethernet fabric, enabling consolidation of LAN, SAN, and cluster environments.

[Figure 1-31](#) shows the ports on the rear of the Cisco Nexus 2232TM-10GE chassis.

Figure 1-31 Ports Located on the Rear of the Cisco Nexus 2232TM-10GE Chassis

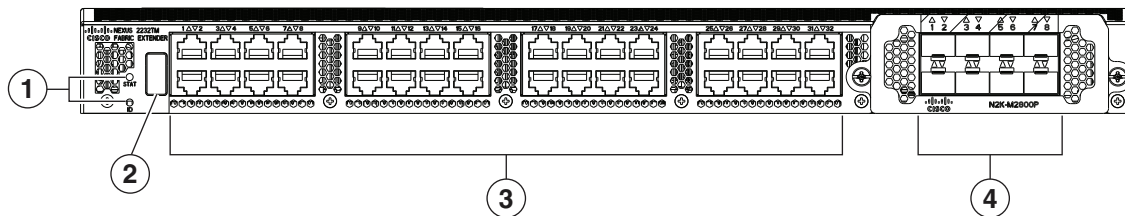

1	Status (top) and ID (bottom) LEDs	3	32 10-Gigabit BaseT host ports
2	HDMI Connector	4	8 10-Gigabit SFP+ ports

Power Supplies

The Cisco Nexus 2232TM-10GE FEX chassis has two bays for fan side AC or DC power supplies. This chassis is fully functional with one power supply, but you can install a second power supply for power redundancy. The power supply is hot-swappable during operations.

Table 1-9 lists the power supplies that you can order with the Cisco Nexus 2232TM-10GE FEX.

Table 1-9 Power Supplies for the Cisco Nexus 2232TM-10GE FEX

Power Supply	Part Number
AC power supply with port-side exhaust airflow	N2K-PAC-400W
AC power supply with port-side intake airflow	N2K-PAC-400W-B
DC power supply with port-side exhaust airflow	N2K-PDC-400W

Figure 1-23 on page 1-20 shows an AC power supply with port-side exhaust airflow. Figure 1-24 on page 1-21 shows an AC power supply with port-side intake airflow. Figure 1-25 on page 1-21 shows a DC power supply with port-side exhaust airflow.

You can order the Cisco Nexus 2232TM-10GE FEX with AC power supplies that have port-side exhaust or port-side intake airflow for cooling or DC power supplies that have port-side exhaust airflow. The port-side intake airflow components have a black stripe on their fan side surface for easy visual identification. The port-side exhaust airflow components do not have a black stripe.



Caution

Be sure that all of the power supply and fan tray modules in the same chassis have the same airflow direction and that the air intake for those modules is positioned on a cool aisle. If you install a module that uses a different direction of airflow from the other modules in your system, you will see an error message. If you position a chassis with its modules taking cooling air from a warm aisle, the switch can over heat and shut down.

If one power supply is installed in the chassis, but the other power supply slot is empty, you should use a blank filler panel (N2200-P-BLNK) to cover the empty slot. Figure 1-26 on page 1-22 shows a blank power supply filler panel.

For power supply specifications, see [Power Specifications, page B-1](#). To replace a power supply, see the “[Removing and Installing Power Supplies](#)” section on page 4-16.

For LED descriptions, see “[Chassis and Module LEDs for the Cisco Nexus Fabric Extenders](#)”.

Fan Trays

The Cisco Nexus 2232TM-10GE FEX has one fan tray that is hot swappable during operations. Depending on whether there is a cold aisle in fan side or port side of the chassis, you can order port-side exhaust airflow or port-side intake airflow for the fan tray and the power supplies in the same chassis. [Table 1-10](#) lists the part numbers for each of the fan trays that you can use with this chassis.

Table 1-10 Fan Trays for the Cisco Nexus 2232TM-10GE FEX

Description	Part Number
Port-side exhaust airflow	N2K-C2232-FAN
Port-side intake airflow	N2K-C2232-FAN-B



Caution

Always make sure that all of the fan tray and power supply modules have the same direction of airflow and the same color designation for that airflow direction. The switch does not support having more than one direction of airflow with its modules.

To see the components used when installing a fan tray, see [Figure 1-32](#) (port-side exhaust airflow) or [Figure 1-33](#) (port-side intake airflow).

Figure 1-32 Port-Side Exhaust Airflow Fan Tray for the Cisco Nexus 2232TM-10GE FEX

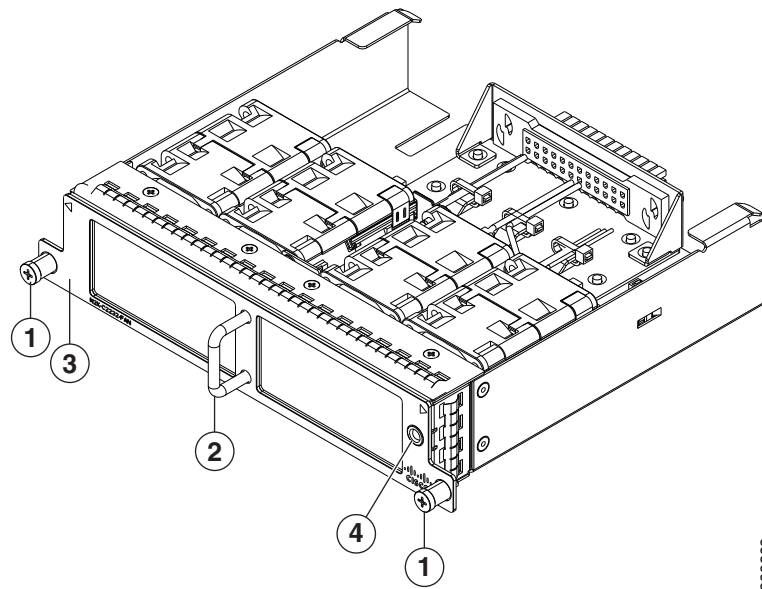

299292

1	Captive screws (2)	3	No black stripe indicates port-side exhaust airflow
2	Handle	4	Status LED

Figure 1-33 Port-Side Intake Airflow Fan Tray for the Cisco Nexus 2232TM-10GE FEX

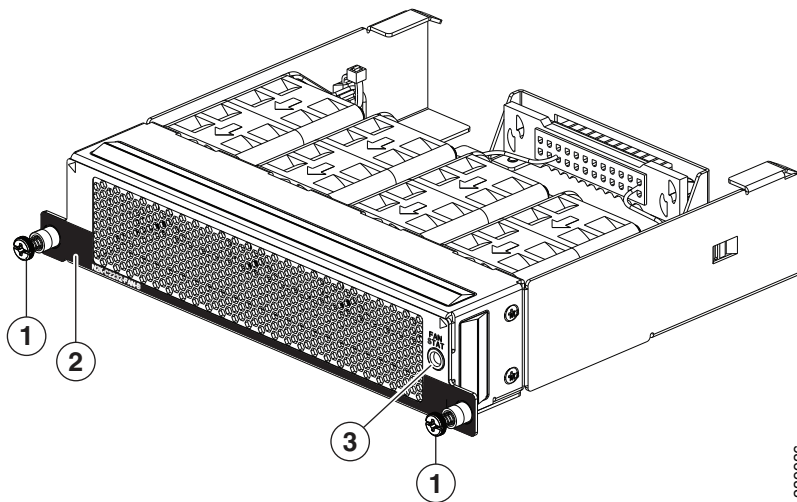

1	Captive screws (2)	3	Status LED
2	Black stripe indicates port-side intake airflow		

To replace a fan tray, see the “[Removing and Installing the Fan Tray](#)” section on page 4-21. For LED descriptions, see [Table E-1](#) on page E-2.

Supported Transceivers and Cables

The Cisco Nexus 2232TM-10GE Series FEX supports SFP+ Ethernet transceivers. The enhanced Small-Form-Factor Pluggable (SFP+) 10-Gigabit Ethernet transceiver is a bidirectional device with a transmitter and receiver. It has a 20-pin connector on the electrical interface and duplex LC connector on the optical interface. Currently, the FEX supports the short-range SFP and long-range SFP transceiver. Copper interface cables are available for use with the 10-Gigabit Ethernet SFP+ transceiver. For an updated list of supported transceivers and optics, please see the [Cisco Nexus 2000 Series Fabric Extenders Release Notes](#).

Cisco Nexus 2224TP

The Cisco Nexus 2224TP is a stackable 1 RU FEX. This FEX is very similar to the Cisco Nexus 2248TP except that it has 24 100/1000BASE-T downlink ports, 2 SFP+ uplink ports and you can order it with port-side exhaust airflow or port-side intake airflow. You can use this FEX with the Cisco Nexus 5000 Series switch. The Cisco Nexus 2224TP is managed and configured by the upstream switch. The FEX

software ships with the Cisco Nexus 5000 Series switch software. The FEX downloads the software image from the switch the same way that a module would download it from the supervisor in a modular chassis.

This section includes the following topics:

- [Chassis, page 1-33](#)
- [Ports, page 1-34](#)
- [Power Supplies, page 1-34](#)
- [Fan Tray, page 1-35](#)
- [Supported SFP+ Transceivers, page 1-36](#)

Chassis

The Cisco Nexus 2224TP chassis has a height of 1.72 inches (4.37 cm), a width of 17.34 inches (44.04 cm), and a depth of 18.9 inches (48.1 cm). It weighs 18 pounds (8.0 kg). Its one-rack-unit (1 RU) form factor takes up relatively little space, making it easy to incorporate into rack designs. The FEX is mounted in a standard 19-inch (48.26-cm) rack. It has port side exhaust or port side intake airflow for cooling. All switch ports are located at the rear of the unit in close proximity to server ports, and all user-serviceable components are accessible from the fan side.

[Figure 1-34](#) shows the location of the components on the fan side of the chassis, and [Figure 1-35](#) shows the location of components on the rear of the chassis. For information on what the chassis and component LEDs indicate, see [Table E-1 on page E-2](#).

Figure 1-34 Fan side of the Cisco Nexus 2224TP Chassis

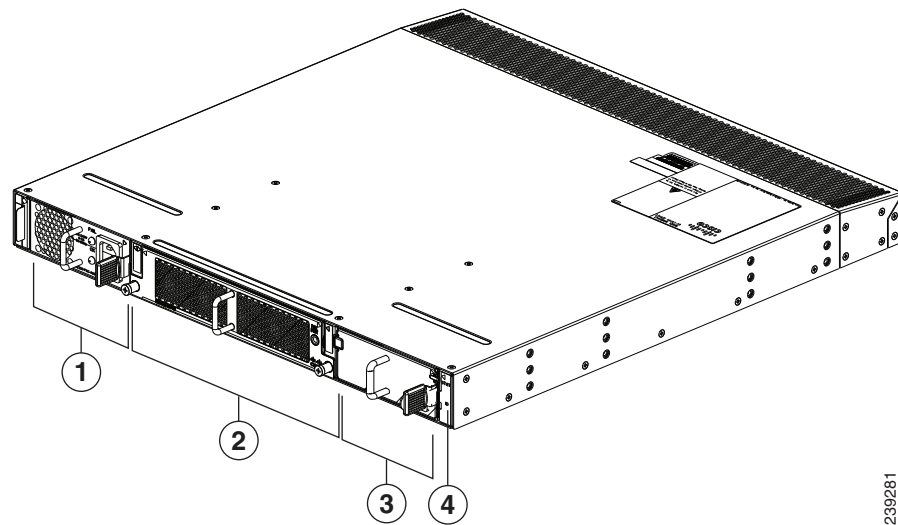

1	Power supply	3	Power supply (blank power supply shown)
2	Fan tray (1)	4	Status (top) and ID (bottom) LEDs

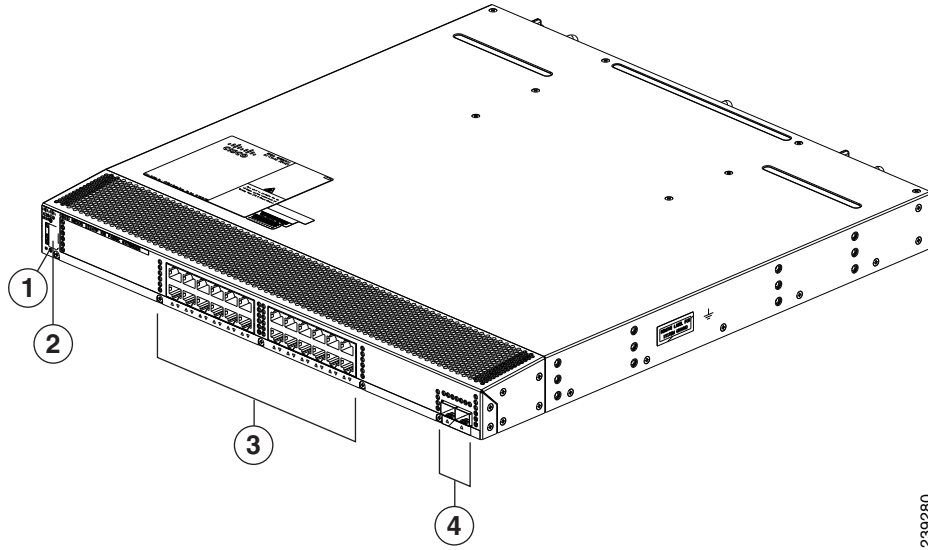
Figure 1-35 Rear View of the Nexus 2224TP Chassis

239280

1	Status (top) and ID (bottom) LEDs	3	100/1000BASE-T data ports (24)
2	HDMI port	4	SFP+ uplink ports (2)

Ports

The Cisco Nexus 2224TP FEX supports a total of 24 100/1000BASE-T downlink ports and two SFP+ uplink ports on the rear panel. There is an HDMI port on the rear panel for console and management port connectivity. Uplink ports are colored yellow for connectivity to the upstream parent Cisco Nexus 5000 Series switch.

Power Supplies

The Cisco Nexus 2224TP FEX chassis has two bays for fan side AC or DC power supplies (the same power supplies used for the Cisco Nexus 2248TP). This chassis is fully functional with one power supply, but you can install a second power supply for power redundancy. The power supply is hot swappable during operations.

[Table 1-11](#) lists the power supplies that you can order with the Cisco Nexus 2224TP FEX.

Table 1-11 Power Supplies for the Cisco Nexus 2224TP FEX

Power Supply	Part Number
AC power supply with port-side exhaust airflow	N2200-PAC-400W
AC power supply with port-side intake airflow	N2200-PAC-400W-B
DC power supply with port-side exhaust airflow	N2200-PDC-400W
DC power supply with port-side intake airflow	N2200-PDC-350W-B

To see the components that you use when installing a power supply unit, see [Figure 1-23 on page 1-20](#) for the AC power supply with port-side exhaust airflow, [Figure 1-24 on page 1-21](#) for the AC power supply with port-side intake airflow, and [Figure 1-25 on page 1-21](#) for the DC power supply with port-side exhaust airflow.

You can order the Cisco Nexus 2224TP FEX with AC power supplies that have port-side exhaust or port-side intake airflow for cooling or DC power supplies that have port-side exhaust airflow. The port-side intake airflow components have a black stripe on their fan side surface for easy visual identification. The port-side exhaust airflow components do not have a black stripe.

**Caution**

Be sure that all of the power supply and fan tray modules in the same chassis have the same airflow direction and that the air intake for those modules is positioned on a cool aisle. If you install a module that uses a different direction of airflow from the other modules in your system, you will see an error message. If you position a chassis with its modules taking cooling air from a warm aisle, the switch can over heat and shut down.

If one power supply is installed in the chassis, but the other power supply slot is empty, you should use a blank filler panel to cover the empty slot. [Figure 1-26 on page 1-22](#) shows a blank power supply filler panel.

For power supply specifications, see [Table B-1 on page B-2](#). To replace a power supply, see the “[Removing and Installing Power Supplies](#)” section on page 4-16.

Fan Tray

The Cisco Nexus 2224TP FEX has one fan tray that is hot swappable during operations. Depending on whether there is a cold aisle in fan side or port-side of the chassis, you can order port-side exhaust airflow or port-side intake airflow for the fan tray and the power supplies in the same chassis. [Table 1-12](#) lists the part numbers for each of the fan trays that you can use with this chassis.

Table 1-12 Fan Trays for the Cisco Nexus 2224TP and 2248TP FEXs

Description	Part Number
port side exhaust airflow	N2K-C2248-FAN
port side intake airflow	N2K-C2248-FAN-B

**Caution**

Always make sure that all of the fan tray and power supply modules have the same direction of airflow and the same color designation for that airflow direction. The switch does not support having more than one direction of airflow with its modules.

To see the components used when installing one of these fan trays, see [Figure 1-27](#) (port side exhaust airflow) or [Figure 1-28](#) (port side intake airflow).

To replace a fan tray, see the “[Removing and Installing the Fan Tray](#)” section on page 4-21. For LED descriptions, see [Table E-1 on page E-2](#).

Supported SFP+ Transceivers

The Cisco Nexus 2224TP FEX supports SFP+ Ethernet transceivers. The enhanced Small-Form-Factor Pluggable (SFP+) 10-Gigabit Ethernet transceiver is a bidirectional device with a transmitter and receiver. It has a 20-pin connector on the electrical interface and duplex LC connector on the optical interface. Currently, the Cisco Nexus 2224TP FEX supports the short-range SFP and long-range SFP transceiver. Copper interface cables are available for use with the 10-Gigabit Ethernet SFP+ transceiver. For an updated list of supported transceivers and optics, please see the [Cisco Nexus 2000 Series Fabric Extenders Release Notes](#).

Cisco Nexus 2148T

The Cisco Nexus 2148T FEX is a 1 RU device that acts as a remote I/O module on the Cisco Nexus 5000 Series switch. All device configurations are managed on the switch and configuration information is downloaded through inband communication to the FEX. You can use this FEX with the Cisco Nexus 5000 Series switch. The FEX software ships with the Cisco Nexus 5000 Series switch software. The FEX downloads the software image from the switch the same way that a module would download it from the supervisor in a modular chassis.

This section includes the following topics:

- [Features, page 1-36](#)
- [Chassis, page 1-36](#)
- [Ports, page 1-38](#)
- [Power Supplies, page 1-38](#)
- [Fan Tray, page 1-39](#)
- [Supported SFP Transceivers, page 1-40](#)

Features

The Cisco Nexus 2148T FEX has the following features:

- Forty-eight 1-Gigabit Ethernet ports
- Four 10-Gigabit Ethernet ports
- Redundant (dual) 200-W modular, hot-swappable power supplies with a power switch on each supply
- Removable fan tray with redundant fans. The fan tray can be removed for hot swapping. If it is not replaced within 60 seconds, the system shuts down.
- Port-side exhaust airflow

Chassis

The Cisco Nexus 2148T FEX has a height of 1.72 inches (4.37 cm), a width of 17.3 inches (43.94 cm), and a depth of 20 inches (50.8 cm). The FEX is mounted in a standard 19-inch (48.24 cm) rack. The chassis requires 1 RU. One fan tray and two power supplies are located at the fan side of the device. The

ports are located at the rear of the device. The chassis has port-side exhaust airflow with cool air entering the chassis through the fan tray and power supply modules and exhausting through the port side of the chassis.

Figure 1-36 identifies the features on the fan side of the Cisco Nexus 2148T FEX.

Figure 1-36 Fan side view of the Cisco Nexus 2148T FEX

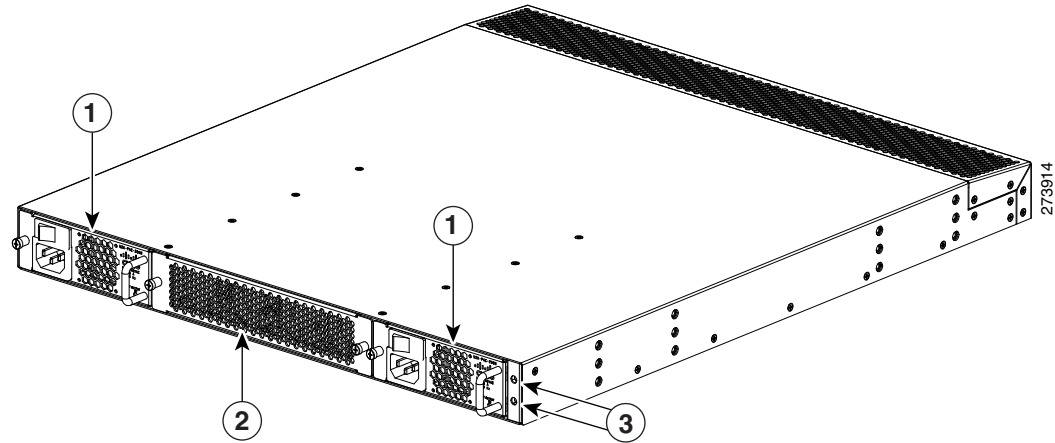

1	Power supply (two)	3	Status (top) and ID (bottom) LEDs
2	Fan tray (1)		

The rear of the Cisco Nexus 2148T FEX has 48 1-Gigabit Ethernet ports, 4 10-Gigabit Ethernet ports, and status and ID LEDs. Figure 1-37 identifies the components found on the rear of the Cisco Nexus 2148T FEX.

Figure 1-37 Rear View of the Cisco Nexus 2148T FEX

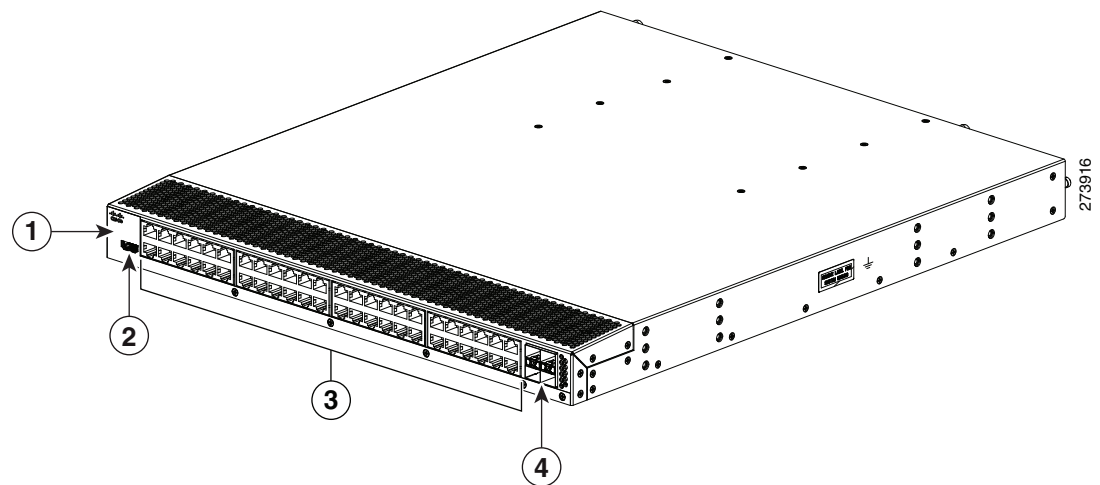

1	System status (top) and Beacon (bottom) LED	3	1-Gigabit Ethernet downlink ports (48)
2	HDMI port	4	10-Gigabit Ethernet uplink ports (4)

Ports

Each port on the Cisco Nexus 2148T FEX is numbered, and groups of ports are numbered based on their function. The ports are numbered from top to bottom and left to right.

Group 1 includes 48 1-Gigabit Ethernet data ports. Group 2 includes four 10-Gigabit Ethernet ports. [Figure 1-38](#) shows how ports are numbered and grouped by function.

Figure 1-38 Port Numbering on the Cisco Nexus 2148T FEX

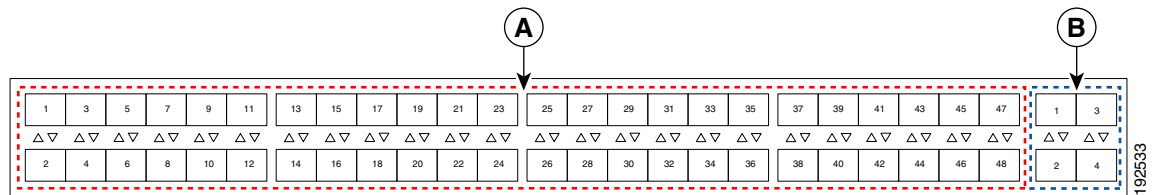

1	Group 1: Data ports 1 through 48	2	Group 2: Uplink ports 1 through 4
----------	----------------------------------	----------	-----------------------------------

Power Supplies

The Cisco Nexus 2148T FEX uses a fan side 200-W AC power supply that has port-side exhaust airflow. The chassis has two bays for two power supplies. Two power supplies can be used for redundancy, but the Cisco Nexus 2148T FEX is fully functional with one power supply. [Figure 1-39](#) shows the power supply with two LEDs: one for power status and one for a failure condition. The power supply is hot-swappable. For details on how to install a power supply, see the “[Removing and Installing Power Supplies](#)” section on page 4-16.

Figure 1-39 AC Power Supply for the Cisco Nexus 2148T Series FEX

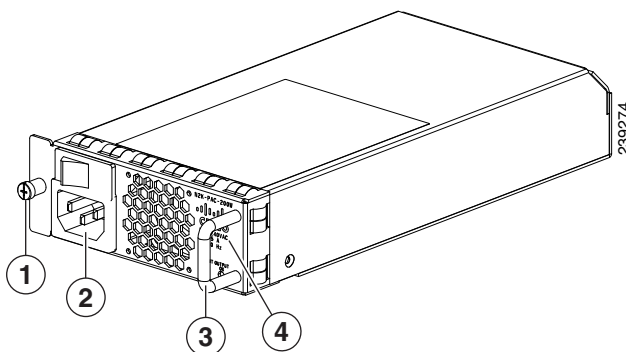

1	Green power LED indicates the power status.	2	Amber fail LED indicates a failure condition.
----------	---	----------	---

If one power supply is installed in the chassis, but the other power supply slot is empty, you should use a blank filler panel to cover the empty slot. [Figure 1-40](#) shows a blank power supply filler panel.

Figure 1-40 Blank Power Supply Filler Panel

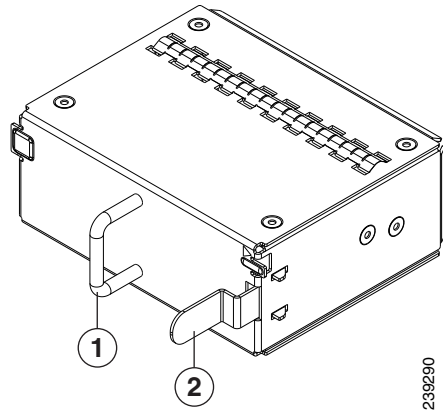

1	Handle	2	Ejector latch
----------	--------	----------	---------------

Fan Tray

The Cisco Nexus 2148T FEX has one fan tray that has port-side exhaust airflow. [Figure 1-41](#) shows the fan tray. The fan tray is hot-swappable as long as you replace it within 60 seconds.

Figure 1-41 Port-Side Exhaust Airflow Fan Tray for Cisco Nexus 2148T FEX

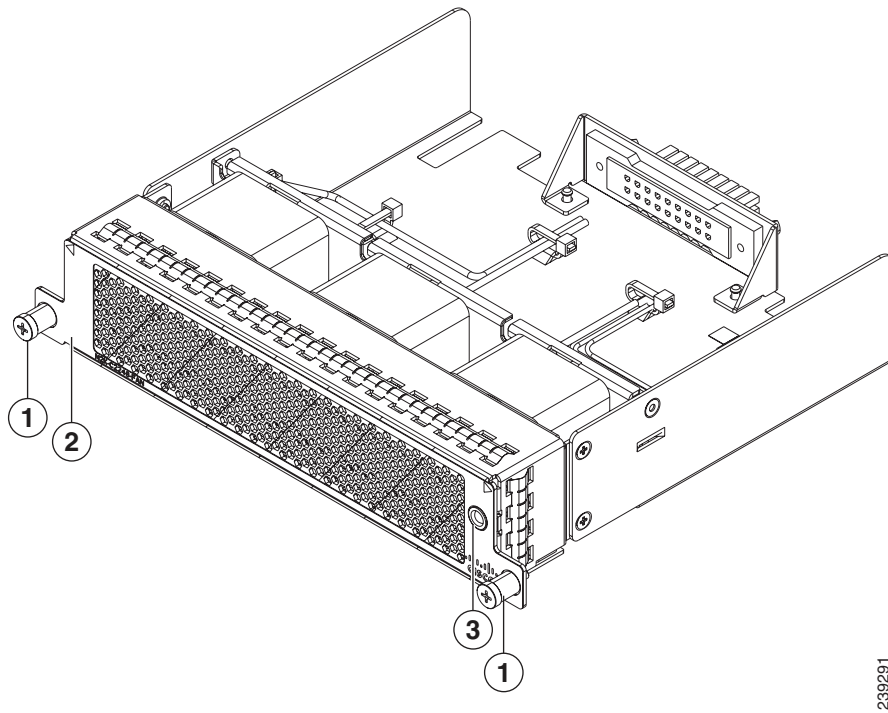

1	Captive screws (2)	2	Status LED
3	No black stripe indicates port-side exhaust airflow		

Supported SFP Transceivers

The Cisco Nexus 2148T FEX supports SFP+ Ethernet transceivers. The enhanced Small-Form-Factor Pluggable (SFP+) 10-Gigabit Ethernet transceiver is a bidirectional device with a transmitter and receiver. It has a 20-pin connector on the electrical interface and duplex LC connector on the optical interface. Currently, the FEX supports the short-range SFP and long-range SFP transceiver. Copper interface cables are available for use with the 10-Gigabit Ethernet SFP+ transceiver. For an updated list of supported transceivers and optics, please see the [Cisco Nexus 2000 Series Fabric Extenders Release Notes](#).



Using a Fabric Extender with a Cisco Nexus 7000 Series Switch

This chapter describes the Cisco Nexus 2200 Platform Fabric Extender (FEX) chassis and the components that you can connect to a Cisco Nexus 7000 Series switch. This chapter includes the following sections:

- [Information About Using a Fabric Extender with a Cisco Nexus 7000 Series Switch, page 2-1](#)
- [Cisco Nexus 2248TP-E FEX, page 2-2](#)
- [Cisco Nexus 2248TP FEX, page 2-11](#)
- [Cisco Nexus 2232TM FEX, page 2-15](#)
- [Cisco Nexus 2232PP FEX, page 2-22](#)
- [Cisco Nexus 2224TP FEX, page 2-27](#)

Information About Using a Fabric Extender with a Cisco Nexus 7000 Series Switch

You can extend the Cisco Nexus 7000 Series switch architecture by connecting up to 32 FEXs as remote I/O modules. Depending on which FEX model that you connect to the switch, the FEX provides top-of-the-rack connectivity for up to 48, 32, or 24 hosts, and it becomes an extension of the parent Cisco Nexus 7000 Series switch fabric, with the FEX and the switch becoming a virtual modular system. The FEX forwards all 100/1000 Ethernet or 1- and 10-Gigabit Ethernet traffic from the hosts to the switch over 10-Gbps uplinks. Traffic flows from the switch to the FEX over the 10-Gbps uplinks and to the individual hosts over 100/1000 Ethernet or 1- and 10-Gigabit Ethernet downlinks.

You connect a FEX uplink port to the Cisco Nexus 7000 Series switch through one of the following Ethernet I/O modules installed in the switch:

- F2 Series 48-port 1 or 10-Gigabit Ethernet I/O module (N7K-F248XP-25)
- M1 Series 32-port 10-Gigabit Ethernet I/O module (N7K-M132XP-12)
- M1 Series 32-port 10-Gigabit Ethernet I/O module with XL option (N7K-M132XP-12L)
- M2 Series 24-port 10-Gigabit Ethernet I/O module (N7K-M224XP-23L)

Cisco Nexus 2248TP-E FEX

The Cisco Nexus 2248TP-E FEX (N2K-C2248TP-E) is a stackable 1-RU FEX that has 48 100/1000 Ethernet host-facing (downlink) ports and four 10-Gigabit Ethernet network-facing (uplink) ports. It requires a 19-inch (48.26 cm) rack for its installation. [Table 2-1](#) lists its physical characteristics.

Table 2-1 Physical Characteristics for the Cisco Nexus 2248TP-E FEX

Dimensions	
Width	17.3 inches (43.9 cm)
Depth	20.0 inches (50.8 cm)
Height	1.72 inches (4.4 cm)
Weight ¹	
	17.7 lb (8.0 kg)

1. Measured with two power supplies and one fan module installed.

You can order the Cisco Nexus 2248TP-E with port-side exhaust or back-to-front airflow and with AC or DC power supplies. If you are going to install the port side in a hot aisle, then order port-side exhaust airflow for all of the fan trays and power supplies. If you are going to install the port side in the cold aisle, order port-side intake airflow for the fan trays and power supplies.



Note

For visual identification, port-side exhaust airflow power supplies and fan trays have a black stripe across their front, and port-side intake airflow modules do not have a black stripe across their front. All of the power supplies and fan trays must have the same direction of airflow for the components to properly function (all of these components must either have a black stripe or all of the components must not have a black stripe).

The front of the Cisco Nexus 2248TP-E FEX chassis has one or two power supplies, a fan tray, and two chassis LEDs as shown in [Figure 2-1](#). This FEX model requires one power supply, but if you want power redundancy, you must install a second power supply.

Figure 2-1 Front View of the Cisco Nexus 2248TP-E Chassis

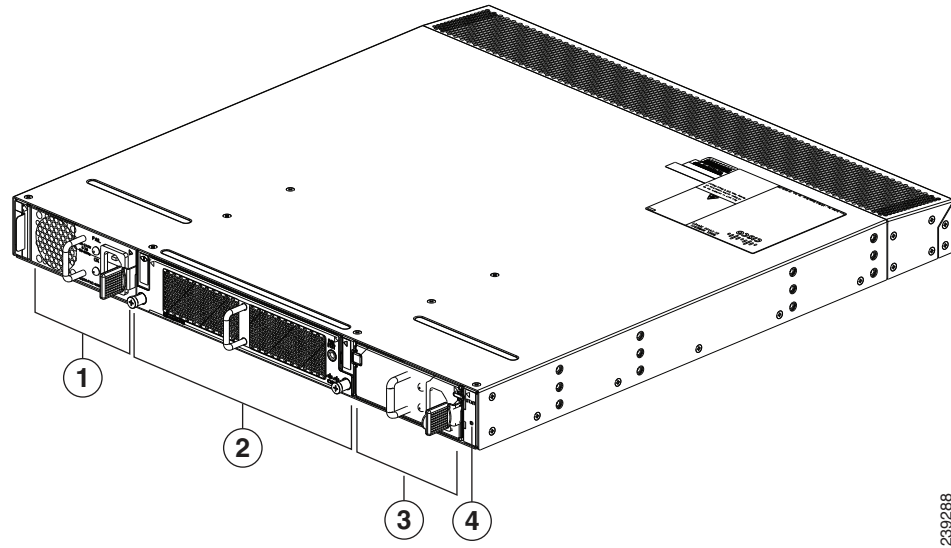

1	Power supply	3	Power supply (blank shown)
2	Fan tray	4	Status (top) and ID (bottom) LEDs

The rear of the Cisco Nexus 2248TP-E FEX chassis has 48 100/1000 Ethernet downlink ports, four 10-Gigabit Ethernet uplink ports, an HDMI port, and LEDs, as shown in [Figure 2-2](#).

Figure 2-2 Rear View of the Cisco Nexus 2248TP-E Chassis

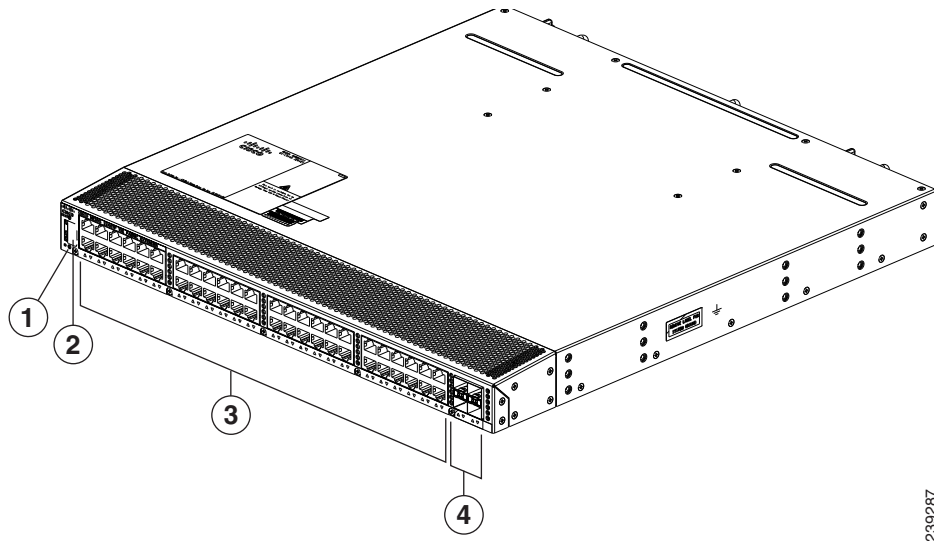

1	Status (top) and ID (bottom) LEDs	3	100/1000 Ethernet host-facing (downlink) ports (48)
2	HDMI port	4	10-Gigabit Ethernet network-facing (uplink) ports (4)

For LED descriptions, see [Appendix E, “LEDs.”](#)

This section includes the following topics:

- [Ports for the Cisco Nexus 2248TP-E FEX, page 2-4](#)
- [Power Supplies for the Cisco Nexus 2248TP-E FEX, page 2-4](#)
- [Fan Tray for the Cisco Nexus 2248TP-E FEX, page 2-7](#)
- [Transceivers and Connectors Supported by the Cisco Nexus 2248TP-E FEX, page 2-9](#)

Ports for the Cisco Nexus 2248TP-E FEX

The downlink and uplink ports are numbered from top to bottom and then left to right as shown in [Figure 2-3](#).

Figure 2-3 Port Numbering on the Cisco Nexus 2248TP-E FEX

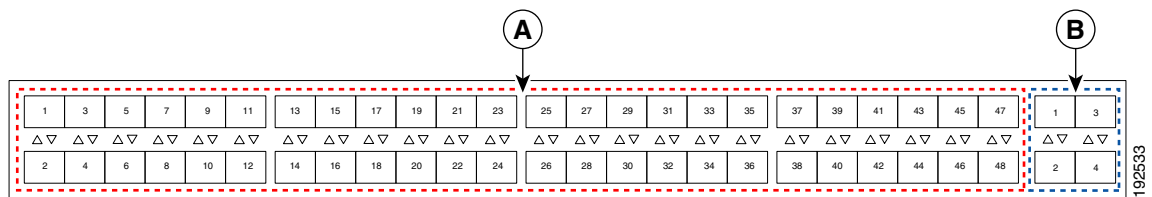

A	100/1000 Ethernet downlink ports, numbered 1 through 48	B	10-Gigabit Ethernet uplink ports, numbered 1 through 4
----------	---	----------	--



Note

For a fully dedicated 10-Gbps bandwidth through a M1 Series 32-port 10-Gigabit Ethernet I/O module (either the N7K-M132XP-12 or N7K-M132XP-12L), connect each FEX to one port in a set of four shared ports on the module (you connect each set of shared ports to one FEX). If you are using the M2 Series 24-port, 10-Gigabit Ethernet I/O module (N7K-M224XP-23L), you can connect the FEX to any of its ports for a fully dedicated bandwidth. If you are using the F2 Series 48-port, 10-Gigabit Ethernet I/O module (N7K-F248XP-25), use the connectivity rule order (connect the same port numbers for each port group (for example, if you connect ports 1 and 2 of a port-group, then connect the same ports of another port group).

For information about the transceivers and connectors that you can use with these ports, see the [“Transceivers and Connectors Supported by the Cisco Nexus 2248TP-E FEX”](#) section on page 2-9.

Power Supplies for the Cisco Nexus 2248TP-E FEX

The Cisco Nexus 2200 Series FEX chassis have two slots for front-end AC or DC power supplies that have port-side exhaust or port-side intake airflow. These chassis are fully functional with one power supply, but you can install a second power supply for power redundancy. If you have only one power supply in the chassis, install a blank filler panel (N2200-P-BLNK) to maintain the designed airflow in the chassis. You can install any of the following power supplies in those two bays:

- AC power supply with port-exhaust airflow (N2200-PAC-400W)

- AC power supply with port-side intake airflow (N2200-PAC-400W-B)
- DC power supply with port-side exhaust airflow (N2200-PDC-400W)
- DC power supply with port-side intake airflow (N2200-PDC-350W-B)



Caution

Make sure that all of the fan tray and power supply modules use the same airflow direction and have the same color designation on the front. Otherwise, the switch can over heat and shut down,

Figure 2-4 shows the exterior components on an AC power supply with port-side exhaust airflow (no black stripe on the front). Figure 2-5 shows the components on a DC power supply with port-side exhaust airflow. Figure 2-6 shows the black stripe used to indicate port-side intake airflow (in this case on an AC power supply). Figure 2-7 shows the blank filler panel that you should install in an open power supply slot if the chassis has only one power supply.

Figure 2-4 AC Power Supply with Port-Side Exhaust Airflow for the Cisco Nexus 2200 Platform

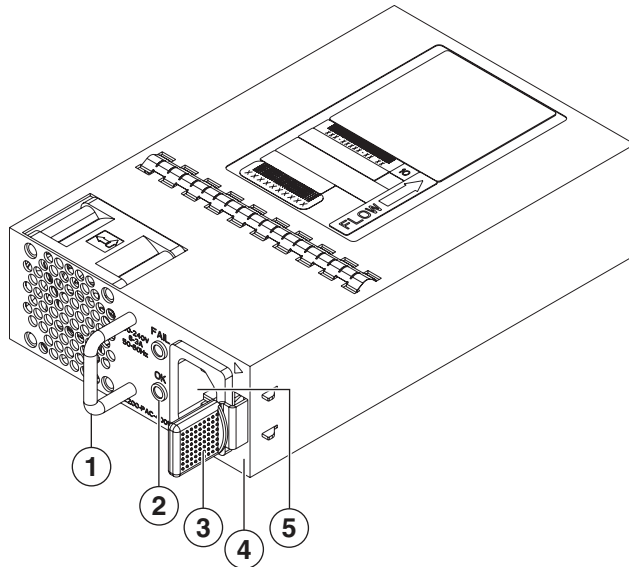

1	Handle	4	No black stripe (port-side exhaust airflow)
2	FAIL (top) and OK (bottom) LEDs	5	AC power receptacle
3	Ejector latch		

Figure 2-5 DC Power Supply with Port-Side Exhaust Airflow for the Cisco Nexus 2200 Platform

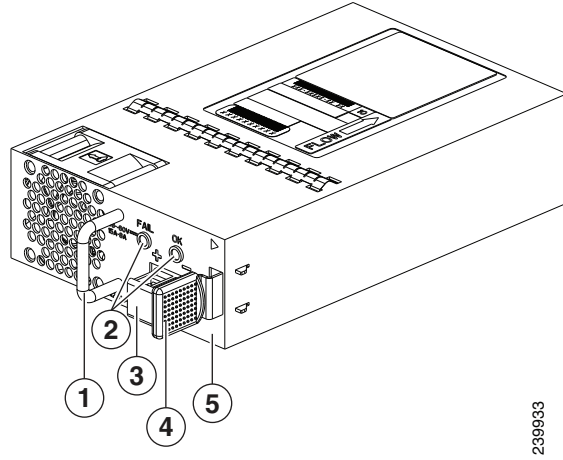

239933

1	Handle	4	Ejector latch
2	FAIL (left) and OK (right) LEDs	5	No black stripe (port-side exhaust airflow)
3	DC power connector with safety cover		

Figure 2-6 Black Stripe Used to Indicate Port-Side Intake Airflow

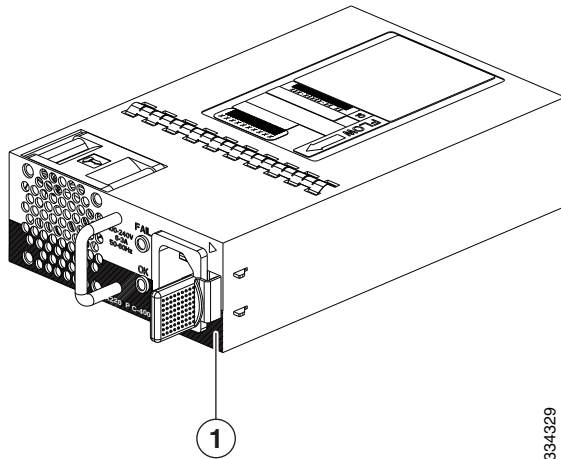

334329

1	Black stripe (port-side intake airflow)		
----------	---	--	--

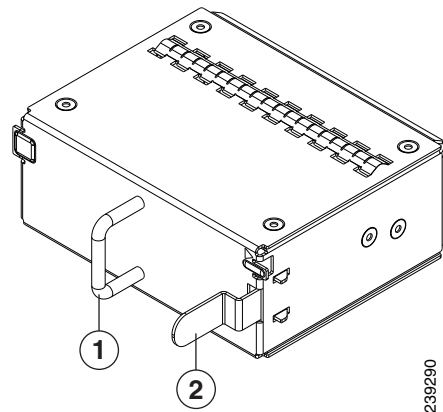
Figure 2-7 Blank Power Supply Filler Panel for a Cisco Nexus 2200 Platform Power Supply Bay

1 Handle	2 Ejector latch
----------	-----------------

For LED descriptions, see [Appendix E, “LEDs”](#).

For power supply specifications, see [Appendix B, “Technical Specifications”](#).

Fan Tray for the Cisco Nexus 2248TP-E FEX

The Cisco Nexus 2224TP, 2248TP, and 2248TP-E FEXs use the same fan tray that you can order with either port-side exhaust airflow (N2K-C2248-FAN) or port-side intake airflow (N2K-C2248-FAN-B). The fan tray includes a status LED that indicates whether the module is operational. You can hot swap the fan tray during operations.



Caution

Make sure that all of the fan tray and power supply modules use the same airflow direction and have the same color designation on the front. Otherwise, the switch can over heat and shut down,

[Figure 2-8](#) shows the fan tray with port-side exhaust airflow (no black stripe on front) and identifies its components, and [Figure 2-9](#) shows the fan tray with port-side intake airflow (black stripe on front) and identifies its components.

Figure 2-8 Port-Side Exhaust Airflow Fan Tray for the Cisco Nexus 2000 Series FEX

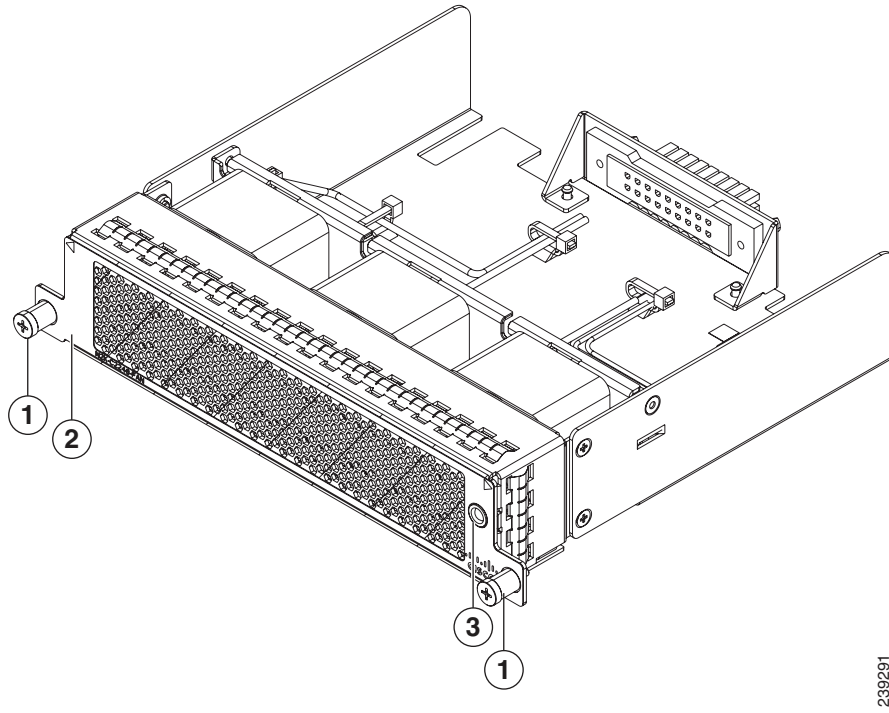

1	Captive screws (2)	3	Status LED
2	No black stripe on the front indicates that this fan tray has port-side exhaust airflow.		

Figure 2-9 Port-Side Intake Airflow Fan Tray for the Cisco Nexus 2000 Series FEX

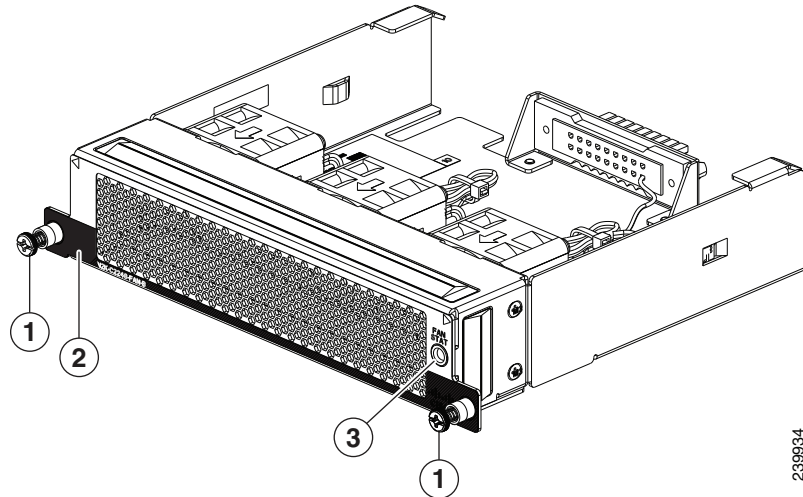

1	Captive screws (2)	3	Status LED
2	Black stripe on the front indicates that this fan tray has port-side intake airflow.		

For information on this fan tray, see the “[Fan Tray for the Cisco Nexus 2248TP FEX](#)” section on [page 2-14](#) and the fan tray specifications in [Appendix B, “Technical Specifications”](#). For LED descriptions, see [Appendix E, “LEDs”](#). To replace one of these fan trays, see the “[Removing and Installing the Fan Tray](#)” section on [page 4-21](#).

Transceivers and Connectors Supported by the Cisco Nexus 2248TP-E FEX

The Cisco Nexus 2248TP-E FEX supports SFP+ Ethernet optical and copper transceivers and optical FEX Transceivers (FETs) for up to four fabric uplink connections to Cisco Nexus 7000 Series switches, and it supports RJ-45 connectors for up to 48 downlink connections to hosts. For each uplink cable, you must use the same transceiver on both ends. [Table 2-2](#) lists the transceivers supported by this FEX for its uplink fabric.

Table 2-2 Supported Transceivers and Connector for the Cisco Nexus 2248TP-E FEX Uplink Interfaces

Transceiver or Connector	Cable Type	Fabric Interface (Uplink)	Host Interface (Downlink)	Comments
FET-10G	Optical	X	–	10 Gbps FEX transceiver
SFP-10G-LR	Optical	X	–	10 Gbps long range transceiver (up to 6.2 miles [10 km])
SFP-10G-SR	Optical	X	–	10 Gbps Short range transceiver (up to 984 feet [300 m])
SFP -H10GB-CU1M	Copper	X	–	10 Gbps Twinax, passive transceiver (3.3 feet [1 meter])
SFP -H10GB-CU3M	Copper	X	–	10 Gbps Twinax, passive transceiver (9.8 feet [3 meters])
SFP -H10GB-CU5M	Copper	X	–	10 Gbps Twinax, passive transceiver (16.4 feet [5 meters])

Table 2-2 Supported Transceivers and Connector for the Cisco Nexus 2248TP-E FEX Uplink Interfaces

Transceiver or Connector	Cable Type	Fabric Interface (Uplink)	Host Interface (Downlink)	Comments
SFP -H10GB-ACU7M	Copper	X	–	10 Gbps Twinax, active transceiver (23.0 feet [7 meters])
SFP -H10GB-ACU10M	Copper	X	–	10 Gbps Twinax, active transceiver (32.8 feet [10 meters])
RJ-45	Copper	–	X	100/1000 Mbps Connector

Figure 2-10 shows the SFP+ optical transceiver used for uplink connections.

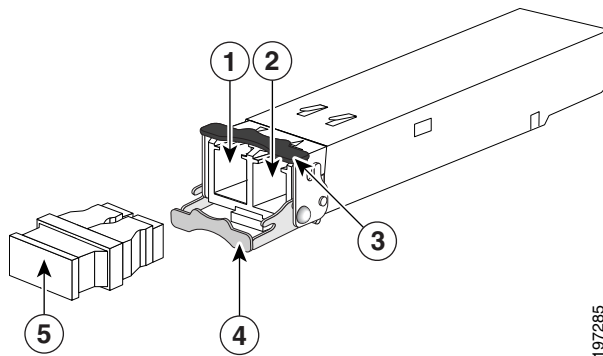
Figure 2-10 SFP+ Optical Transceivers and FETs

1	Receive optical bore	4	Clasp shown in open position
2	Transmit optical bore	5	Dust plug (use this to protect the bores from dust contamination when the optical cables are removed)
3	Clasp shown in closed position		

Figure 2-11 identifies the major features of the SFP+ copper transceiver and cable used for uplink connections.

Figure 2-11 SFP+ Copper Transceiver Module

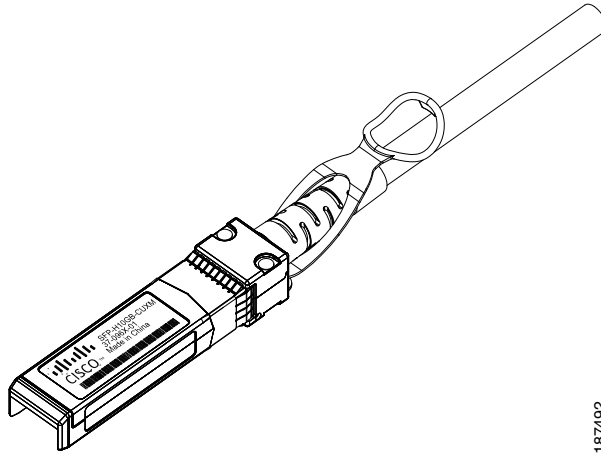
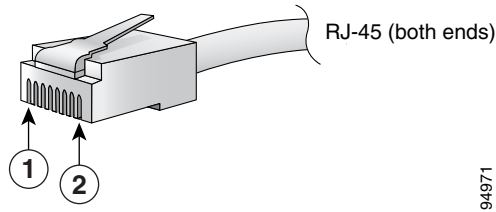

Figure 2-12 identifies the major features of RJ-45 connectors, which are used for the downlink connections.

Figure 2-12 RJ-45 Connector



1	Pin 1	2	Pin 8
----------	-------	----------	-------

Cisco Nexus 2248TP FEX

The Cisco Nexus 2248TP FEX is a stackable 1-RU FEX that has 48 100/1000 Ethernet host-facing (downlink) ports and four 10-Gigabit Ethernet network-facing (uplink) ports. It requires a 19-inch (48.26 cm) rack for its installation. Table 2-3 lists its physical characteristics.

Table 2-3 Physical Characteristics for the Cisco Nexus 2248TP FEX

Dimensions	
Width	17.3 inches (43.9 cm)
Depth	20.0 inches (50.8 cm)
Height	1.72 inches (4.4 cm)
Weight ¹	17.7 lb (8.0 kg)

1. Measured with two power supplies and one fan module installed.

You can order the Cisco Nexus 2248TP with port-side exhaust or port-side intake airflow and with AC or DC power supplies. If you are going to install the ports in a hot aisle, then order port-side exhaust airflow for all of the fan trays and power supplies. If you are going to install the ports in the cold aisle, order port-side intake airflow for all of the fan trays and power supplies.

**Caution**

Make sure that all of the fan tray and power supply modules use the same airflow direction and have the same color designation on the front. Otherwise, the switch can over heat and shut down,

**Note**

For visual identification, port-side exhaust airflow fan trays and power supplies have a black stripe across their front, and port-side intake airflow modules do not have a black stripe across their front. All of the power supplies and fan trays must have the same direction of airflow for the components to properly function (all of these components must either have a black stripe or all of the components must not have a black stripe).

The front of the Cisco Nexus 2248TP FEX chassis has one or two power supplies, a fan tray, and two chassis LEDs as shown in [Figure 2-13](#). This FEX model requires one power supply, but if you want power redundancy, you must install a second power supply.

Figure 2-13 Front View of the Cisco Nexus 2248TP Chassis

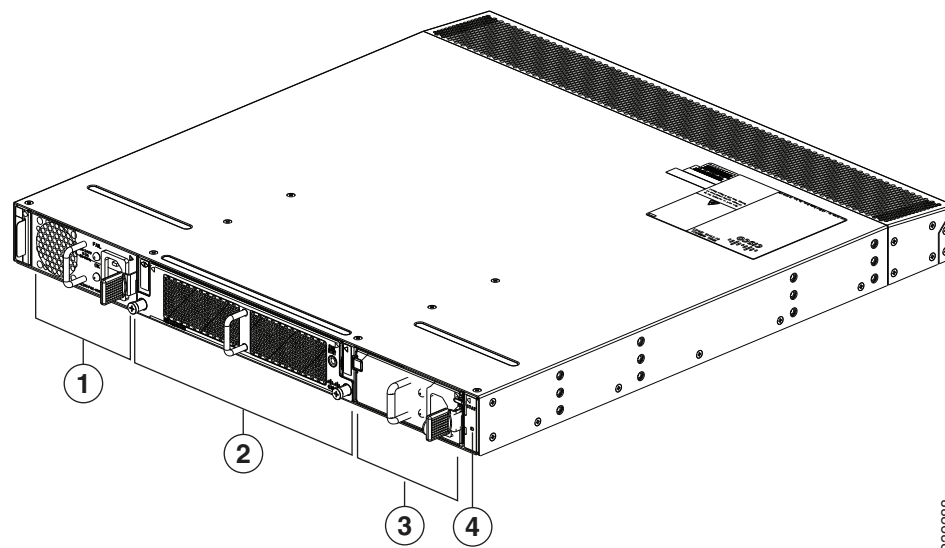

1	Power supply	3	Power supply (blank shown)
2	Fan tray	4	Status (top) and ID (bottom) LEDs

The rear of the Cisco Nexus 2248TP-E FEX has 48 100/1000 Ethernet downlink ports, four 10-Gigabit Ethernet uplink ports, an HDMI port, and LEDs, as shown in [Figure 2-14](#).

Figure 2-14 Rear View of the Cisco Nexus 2248TP Chassis

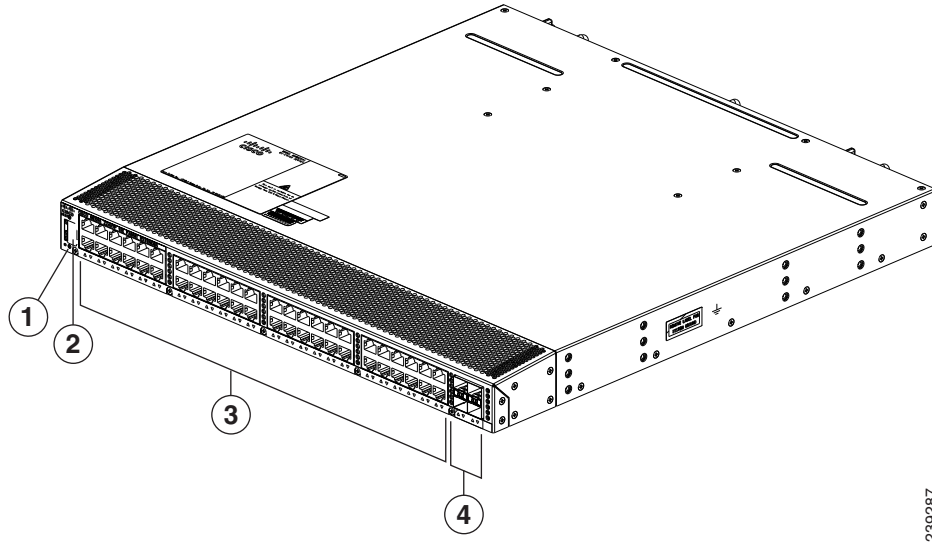

1	Status (top) and ID (bottom) LEDs	3	100/1000 Ethernet host-facing (downlink) ports (48)
2	HDMI port	4	10-Gigabit Ethernet network-facing (uplink) ports (4)

For LED descriptions, see [Appendix E, “LEDs.”](#)

This section includes the following topics:

- [Ports for the Cisco Nexus 2248TP FEX, page 2-13](#)
- [Power Supplies for the Cisco Nexus 2248TP FEX, page 2-14](#)
- [Fan Tray for the Cisco Nexus 2248TP FEX, page 2-14](#)
- [Transceivers and Connectors Supported by the Cisco Nexus 2248TP FEX, page 2-14](#)

Ports for the Cisco Nexus 2248TP FEX

The downlink and uplink ports are numbered from top to bottom and then left to right as shown in [Figure 2-15](#).

Figure 2-15 Port Numbering on the Cisco Nexus 2248TP FEX

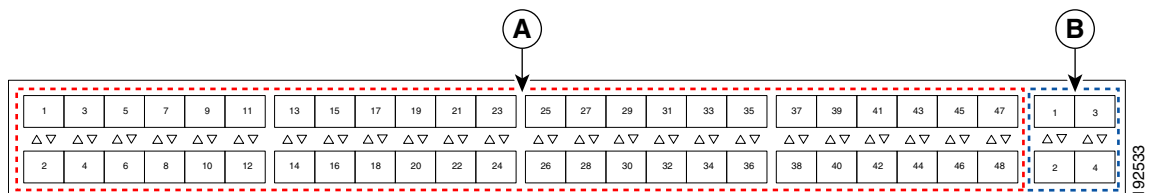

A	100/1000 Ethernet downlink ports, numbered 1 through 48	B	10-Gigabit Ethernet uplink ports, numbered 1 through 4
----------	---	----------	--

**Note**

For a fully dedicated 10-Gbps bandwidth through a M1 Series 32-port 10-Gigabit Ethernet I/O module (either the N7K-M132XP-12 or N7K-M132XP-12L), connect each FEX to one port in a set of four shared ports on the module (you connect each set of shared ports to one FEX). If you are using the M2 Series 24-port, 10-Gigabit Ethernet I/O module (N7K-M224XP-23L), you can connect the FEX to any of its ports for a fully dedicated bandwidth. If you are using the F2 Series 48-port, 10-Gigabit Ethernet I/O module (N7K-F248XP-25), use the connectivity rule order (connect the same port numbers for each port group (for example, if you connect ports 1 and 2 of a port-group, then connect the same ports of another port group)).

For information about the transceivers and connectors that you can use with these ports, see the [“Transceivers and Connectors Supported by the Cisco Nexus 2248TP FEX”](#) section on page 2-14.

Power Supplies for the Cisco Nexus 2248TP FEX

The Cisco Nexus 2200 Platform FEX chassis have two slots for front-end AC or DC power supplies that have port-side exhaust or port-side intake airflow. These chassis are fully functional with one power supply, but you can install a second power supply for power redundancy. You can install any of the following power supplies in those two bays:

- AC power supply with port-side exhaust airflow (N2200-PAC-400W)
- AC power supply with port-side intake airflow (N2200-PAC-400W-B)
- DC power supply with port-side exhaust airflow (N2200-PDC-400W)
- DC power supply with port-side intake airflow (N2200-PDC-350W-B)

**Caution**

Make sure that all of the fan tray and power supply modules use the same airflow direction and have the same color designation on the front. Otherwise, the switch can over heat and shut down,

For information on these power supplies, see the [“Power Supplies for the Cisco Nexus 2248TP FEX”](#) section on page 2-14 and the power supply specifications in [Appendix B, “Technical Specifications.”](#). To replace one of these power supplies, see the [“Removing and Installing Power Supplies”](#) section on page 4-16.

Fan Tray for the Cisco Nexus 2248TP FEX

The Cisco Nexus 2224TP, 2248TP, and 2248TP-E FEXs use the same fan tray that you can order with either port-side exhaust airflow (N2K-C2248-FAN) or port-side intake airflow (N2K-C2248-FAN-B).

For information on this fan tray, see the [“Fan Tray for the Cisco Nexus 2248TP-E FEX”](#) section on page 2-7. For LED descriptions, see [Appendix E, “LEDs”](#).

Transceivers and Connectors Supported by the Cisco Nexus 2248TP FEX

The Cisco Nexus 2248TP FEX supports SFP+ Ethernet optical and copper transceivers and optical FEX Transceivers (FETs) for up to four fabric uplink connections to Cisco Nexus 7000 Series switches, and it supports RJ-45 connectors for up to 48 downlink connections to hosts. For each uplink cable, you must use the same transceiver on both ends. [Table 2-2](#) lists the transceivers supported by this FEX for its

uplink fabric.

Table 2-4 Supported Transceivers and Connector for the Cisco Nexus 2248TP FEX Uplink Interfaces

Transceiver or Connector	Cable Type	Fabric Interface (Uplink)	Host Interface (Downlink)	Comments
FET-10G	Optical	X	–	10 Gbps FEX transceiver
SFP-10G-LR	Optical	X	–	10 Gbps long range transceiver (up to 6.2 miles [10 km])
SFP-10G-SR	Optical	X	–	10 Gbps Short range transceiver (up to 984 feet [300 m])
SFP -H10GB-CU1M	Copper	X	–	10 Gbps Twinax, passive transceiver (3.3 feet [1 meter])
SFP -H10GB-CU3M	Copper	X	–	10 Gbps Twinax, passive transceiver (9.8 feet [3 meters])
SFP -H10GB-CU5M	Copper	X	–	10 Gbps Twinax, passive transceiver (16.4 feet [5 meters])
SFP -H10GB-ACU7M	Copper	X	–	10 Gbps Twinax, active transceiver (23.0 feet [7 meters])
SFP -H10GB-ACU10M	Copper	X	–	10 Gbps Twinax, active transceiver (32.8 feet [10 meters])
RJ-45	Copper	–	X	100/1000 Mbps Connector

Figure 2-10 on page 2-10 shows the SFP+ optical transceiver used for uplink connections.

Figure 2-11 on page 2-11 identifies the major features of the SFP+ copper transceiver and cable used for uplink connections.

Figure 2-12 on page 2-11 identifies the major features of RJ-45 connectors, which are used for the downlink connections.

Cisco Nexus 2232TM FEX

The Cisco Nexus 2232TM FEX is a stackable, 1- and 10-Gigabit FEX that has 32 1- and 10-Gbps Ethernet host-facing (downlink) 1/10GBASE-T ports and eight 10-Gbps Ethernet network-facing (uplink) SFP+ ports. It requires a 19-inch (48.26 cm) rack for its installation. Table 2-7 lists its physical characteristics.

Table 2-5 Physical Characteristics for the Cisco Nexus 2232TM FEX

Dimensions	
Width	17.3 inches (43.94 cm)
Depth	17.7 inches (44.96 cm)
Height	1.72 inches (4.37 cm)
Weight ¹	
	18.3 lb (8.3 kg)

1. Measured with two power supplies and one fan module installed

You can order the Cisco Nexus 2232TM with port-side exhaust or port-side intake airflow and with AC or DC power supplies. If you are going to install the port side in a hot aisle, then order port-side exhaust airflow for all of the fan trays and power supplies. If you are going to install the port side in the cold aisle, order port-side intake airflow for all of the fan trays and power supplies.

**Caution**

Make sure that all of the fan tray and power supply modules use the same airflow direction and have the same color designation on the front. Otherwise, the switch can over heat and shut down,

The front of the Cisco Nexus 2232TM FEX chassis has one or two power supplies, a fan tray, and two LEDs as shown in [Figure 2-16](#). This FEX model requires one power supply, but if you want power redundancy, you must install a second power supply.

Figure 2-16 Front View of the Cisco Nexus 2232TM Chassis

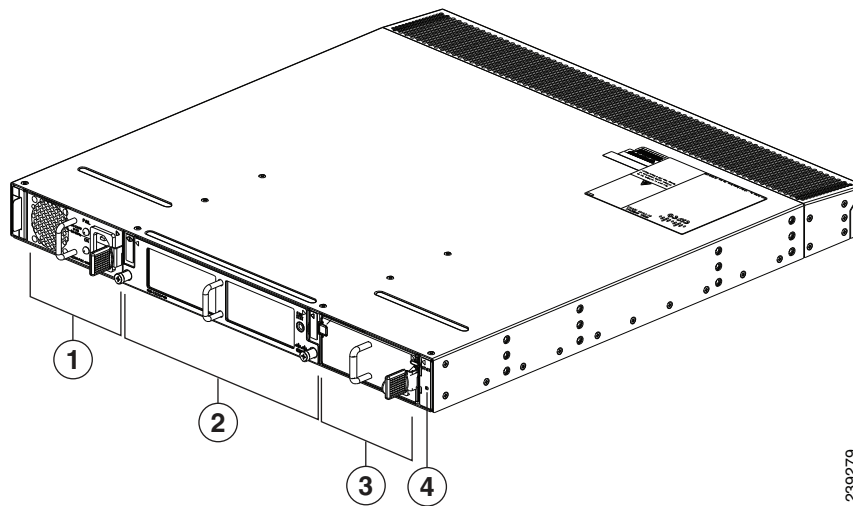

1	Power supply	3	Power supply (blank shown)
2	Fan tray	4	Status (top) and ID (bottom) LEDs

The rear of the Cisco Nexus 2232TM FEX has 32 1- and 10-Gigabit Ethernet downlink ports, eight 10-Gigabit Ethernet uplink ports, an HDMI port, and two LEDs, as shown in [Figure 2-22](#).

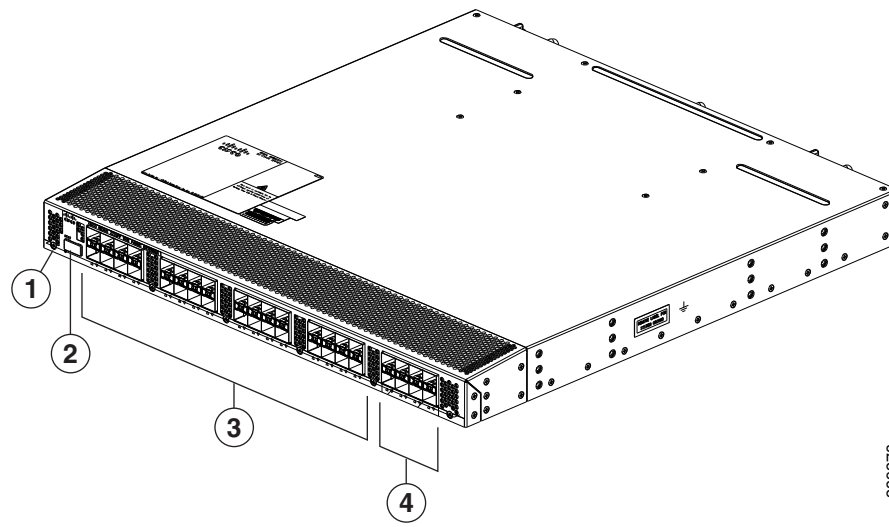
Figure 2-17 Rear View of the Cisco Nexus 2232TM Chassis

239278

1	Status (top) and ID (bottom) LEDs	3	1- and 10-Gigabit host-facing Ethernet (downlink) ports (48)
2	HDMI port	4	10-Gigabit network-facing Ethernet (uplink) ports (8)

For LED descriptions, see [Appendix E, “LEDs.”](#)

This section includes the following topics:

- [Ports for the Cisco Nexus 2232TM FEX, page 2-17](#)
- [Power Supplies for the Cisco Nexus 2232TM FEX, page 2-18](#)
- [Fan Tray for the Cisco Nexus 2232TM FEX, page 2-19](#)
- [Transceivers and Connectors Supported by the Cisco Nexus 2232TM FEX, page 2-20](#)

Ports for the Cisco Nexus 2232TM FEX

The downlink and uplink ports are numbered from top to bottom and then from left to right as shown in [Figure 2-23](#).

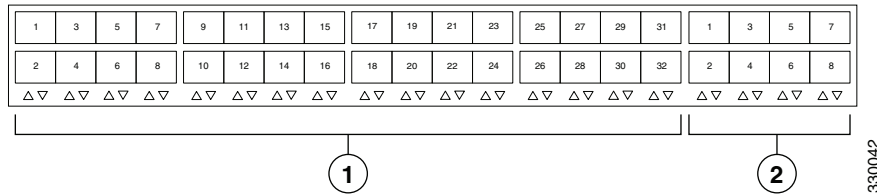
Figure 2-18 Port Numbering on the Cisco Nexus 2232TM FEX

1	1- and 10-Gigabit Ethernet downlink ports, numbered 1 through 32	2	10-Gigabit Ethernet uplink ports, numbered 1 through 8
----------	--	----------	--

**Note**

For a fully dedicated 10-Gbps bandwidth through a M1 Series 32-port 10-Gigabit Ethernet I/O module (either the N7K-M132XP-12 or N7K-M132XP-12L), connect each FEX to one port in a set of four shared ports on the module (you connect each set of shared ports to one FEX). If you are using the M2 Series 24-port, 10-Gigabit Ethernet I/O module (N7K-M224XP-23L), you can connect the FEX to any of its ports for a fully dedicated bandwidth. If you are using the F2 Series 48-port, 10-Gigabit Ethernet I/O module (N7K-F248XP-25), use the connectivity rule order (connect the same port numbers for each port group (for example, if you connect ports 1 and 2 of a port-group, then connect the same ports of another port group)).

For information about the transceivers and connectors that you can use with these ports, see the [“Transceivers and Connectors Supported by the Cisco Nexus 2232TM FEX”](#) section on page 2-20.

Power Supplies for the Cisco Nexus 2232TM FEX

The Cisco Nexus 2200 Platform FEX chassis have two slots for front-end AC or DC power supplies that have port-side exhaust or port-side intake airflow. These chassis are fully functional with one power supply, but you can install a second power supply for power redundancy. You can install any of the following power supplies in those two bays:

- AC power supply with port-side exhaust airflow (N2200-PAC-400W)
- AC power supply with port-side intake airflow (N2200-PAC-400W-B)
- DC power supply with port-side exhaust airflow (N2200-PDC-400W)
- DC power supply with port-side intake airflow (N2200-PDC-350W-B)

**Caution**

Make sure that all of the fan tray and power supply modules use the same airflow direction and have the same color designation on the front. Otherwise, the switch can over heat and shut down,

If you have only one power supply in a chassis, then you must install a blank filler plate (N2200-P-BLNK) in the open slot to maintain the designed airflow.

For more information on these power supplies, see the [“Power Supplies for the Cisco Nexus 2248TP-E FEX”](#) section on page 2-4 and the power supply specifications in the [Appendix B, “Technical Specifications”](#).

Fan Tray for the Cisco Nexus 2232TM FEX

The Cisco Nexus 2232PP and 2232TM FEX use the same fan tray, which you can order with either port-side exhaust airflow (N2K-C2248-FAN) or port-side intake airflow (N2K-C2248-FAN-B). The fan tray includes a status LED that indicates whether the module is operational.



Caution

Make sure that all of the fan tray and power supply modules use the same airflow direction and have the same color designation on the front. Otherwise, the switch can over heat and shut down,

Figure 2-19 shows the fan tray with port-side exhaust airflow (no black stripe across the front), and Figure 2-20 shows the fan tray with port-side intake airflow (black stripe across the front).

Figure 2-19 Port-Side Exhaust Airflow Fan Tray for the Cisco Nexus 2232PP and 2232TM FEXs

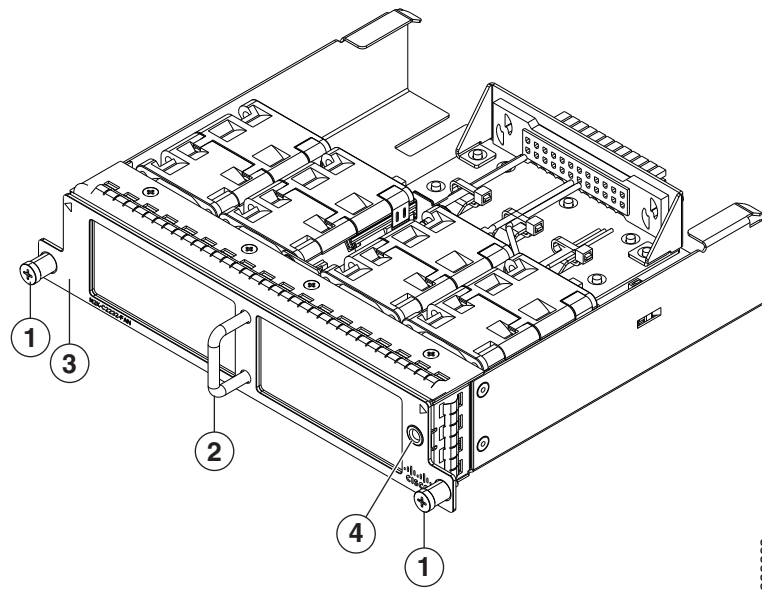

1	Captive screws (2)	3	Port-side exhaust airflow indicated by a lack of black stripe on the front.
2	Handle used for removing and installing the module	4	Status LED

Figure 2-20 Port-Side Intake Airflow Fan Tray for the Cisco Nexus 2232PP and 2232TM FEXs

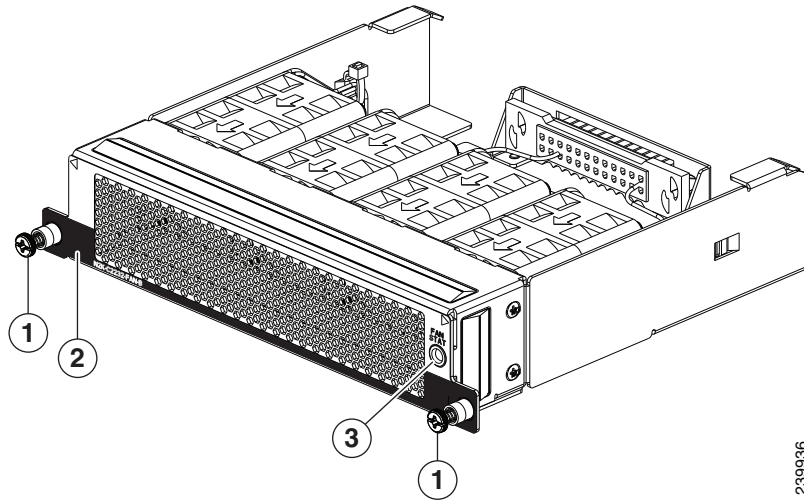

1	Captive screws (2)	3	Port-side intake airflow indicated by a black stripe on the front.
2	Handle used for removing and installing the module	4	Status LED

For more information on this fan tray, see the fan tray specifications in [Appendix B, “Technical Specifications”](#). For LED descriptions, see [Appendix E, “LEDs”](#).

Transceivers and Connectors Supported by the Cisco Nexus 2232TM FEX

The Cisco Nexus 2232TM FEX supports SFP+ Ethernet optical and copper transceivers and optical FEX Transceivers (FETs) for up to eight fabric uplink connections to the following Cisco Nexus 7000 Series switch I/O modules:

- F2 Series 48-port 10-Gigabit I/O module (N7K-F248XP-25)
- M1 Series 32-port, 10-Gigabit Ethernet I/O module (N7K-M132XP-12)
- M1 Series 32-port, 10-Gigabit Ethernet I/O module with XL option (N7K-M132XP-12L)
- M2 Series 24-port 10-Gigabit I/O module (N7K-M224XP-23L)

You must use the same transceivers on both ends of the same uplink cable.

**Note**

To get the fully dedicated 10-Gbps bandwidth through a M1 Series 32-port 10-Gigabit Ethernet I/O module, connect each FEX to one port in a set of four shared ports on the module (you connect each set of shared ports to one FEX) and use the shared mode on the I/O module. If you are using the F2 Series 48-port 10-Gigabit Ethernet I/O module (N7K-F248XP-25) or the M2 Series 24-port 10-Gigabit Ethernet I/O module (N7K-M224XP-23L), you can connect the FEX to any of its ports.

The Cisco Nexus 2232TM FEX also supports RJ-45 connectors for up to 32 downlink connections to hosts. [Table 2-2](#) lists the transceivers supported by this FEX for its uplink and downlink connections.

Table 2-6 Supported Transceivers and Connector for the Cisco Nexus 2232TM FEX Uplink Interfaces

Transceiver or Connector	Cable Type	Fabric Interface (Uplink)	Host Interface (Downlink)	Comments
FET-10G	Optical	X	–	10 Gbps FEX transceiver
SFP-10G-LR	Optical	X	–	10 Gbps long range transceiver (up to 6.2 miles [10 km])
SFP-10G-SR	Optical	X	–	10 Gbps Short range transceiver (up to 984 feet [300 m])
SFP -H10GB-CU1M ¹	Copper	X	–	10 Gbps Twinax, passive transceiver (3.3 feet [1 meter])
SFP -H10GB-CU3M	Copper	X	–	10 Gbps Twinax, passive transceiver (9.8 feet [3 meters])
SFP -H10GB-CU5M	Copper	X	–	10 Gbps Twinax, passive transceiver (16.4 feet [5 meters])
SFP -H10GB-ACU7M	Copper	X	–	10 Gbps Twinax, active transceiver (23.0 feet [7 meters])
SFP -H10GB-ACU10M	Copper	X	–	10 Gbps Twinax, active transceiver (32.8 feet [10 meters])
RJ-45	Copper	–	X	100/1000 Mbps Connector

1. The SFP-H10GB-CUxM transceivers are not supported by the M1 Series 32-port 10-Gigabit Ethernet I/O module (N7K-M132XP-12). These transceivers are supported by the other Cisco Nexus 7000 Series I/O modules.

[Figure 2-10 on page 2-10](#) shows the major features of the SFP+ optical transceiver used for uplink connections.

[Figure 2-11 on page 2-11](#) shows the major features of the SFP+ copper transceiver and cable used for uplink connections.

[Figure 2-12 on page 2-11](#) shows the major features of RJ-45 connectors, which are used for the downlink connections.

Cisco Nexus 2232PP FEX

The Cisco Nexus 2232PP FEX is a stackable 1- and 10-Gigabit FEX that has 32 1- and 10-Gbps Ethernet host-facing (downlink) SFP or SFP+ ports and eight 10-Gbps Ethernet and Fibre Channel over Ethernet (FCoE) network-facing (uplink) SFP+ or FET ports. It requires a 19-inch (48.26 cm) rack for its installation. [Table 2-7](#) lists its physical characteristics.

Table 2-7 Physical Characteristics for the Cisco Nexus 2232PP FEX

Dimensions	
Width	17.3 inches (43.94 cm)
Depth	17.7 inches (44.96 cm)
Height	1.72 inches (4.37 cm)
Weight ¹	18.3 lb (8.3 kg)

1. Measured with two power supplies and one fan module installed

You can order the Cisco Nexus 2232PP with port-side exhaust or port-side intake airflow and with AC or DC power supplies. If you are going to install the port side in a hot aisle, then order port-side exhaust airflow for all of the fan trays and power supplies. If you are going to install the port side in the cold aisle, order port-side intake airflow for all of the fan trays and power supplies.



Caution

Make sure that all of the fan tray and power supply modules use the same airflow direction and have the same color designation on the front. Otherwise, the switch can over heat and shut down,

The front of the Cisco Nexus 2232PP FEX chassis has one or two power supplies, a fan tray, and two LEDs as shown in [Figure 2-21](#). This FEX model requires one power supply, but if you want power redundancy, you must install a second power supply.

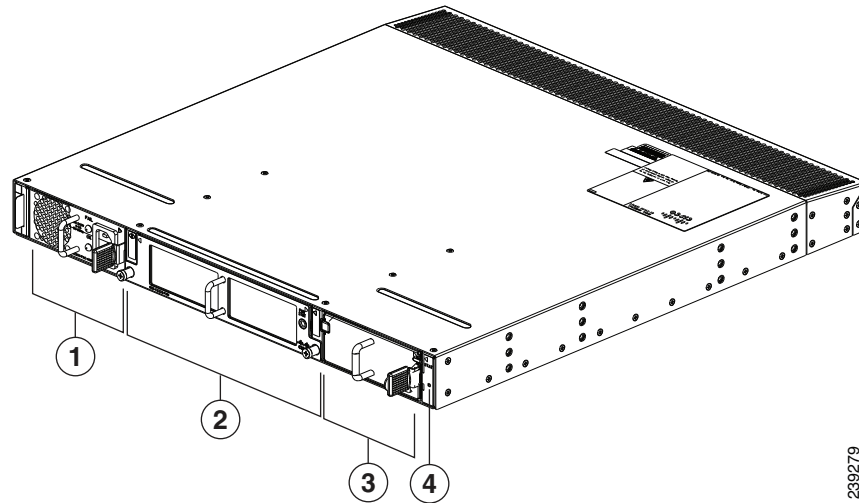
Figure 2-21 Front View of the Cisco Nexus 2232PP Chassis

1	Power supply	3	Power supply (blank shown)
2	Fan tray	4	Status (top) and ID (bottom) LEDs

The rear of the Cisco Nexus 2232PP FEX has 32 1- and 10-Gigabit Ethernet downlink SFP or SFP+ ports, eight 10-Gigabit Ethernet uplink SFP+ or FET ports, an HDMI port, and two LEDs, as shown in [Figure 2-22](#).

Figure 2-22 Rear View of the Cisco Nexus 2232PP Chassis

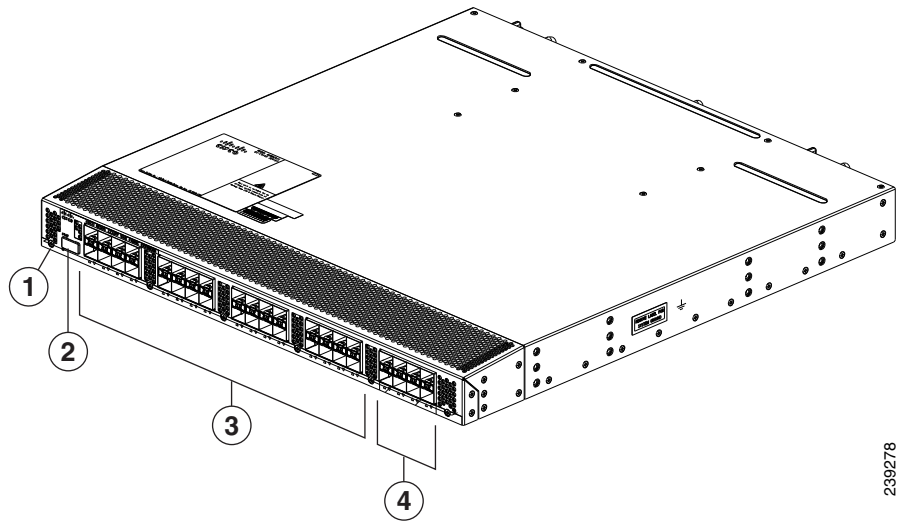

239278

1	Status (top) and ID (bottom) LEDs	3	1- and 10-Gigabit host-facing Ethernet (downlink) SFP or SFP+ ports (48)
2	HDMI port	4	10-Gigabit network-facing Ethernet (uplink) SFP+ ports (4)

For LED descriptions, see [Appendix E, “LEDs.”](#)

This section includes the following topics:

- [Ports for the Cisco Nexus 2232PP FEX, page 2-24](#)
- [Power Supplies for the Cisco Nexus 2232PP FEX, page 2-25](#)
- [Fan Tray for the Cisco Nexus 2232PP FEX, page 2-26](#)
- [Transceivers Supported by the Cisco Nexus 2232PP FEX, page 2-26](#)

Ports for the Cisco Nexus 2232PP FEX

The downlink and uplink ports are numbered from top to bottom and then from left to right as shown in [Figure 2-23](#).

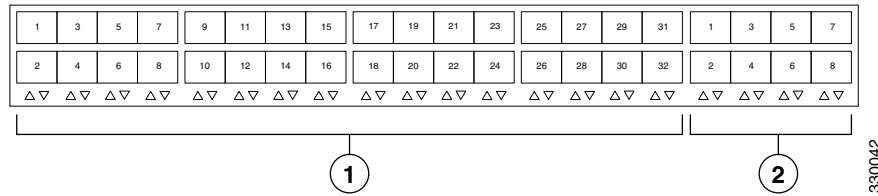
Figure 2-23 Port Numbering on the Cisco Nexus 2232PP FEX

1	1- and 10-Gigabit Ethernet downlink ports, numbered 1 through 32	2	10-Gigabit Ethernet uplink ports, numbered 1 through 8
----------	--	----------	--

**Note**

For a fully dedicated 10-Gbps bandwidth through a M1 Series 32-port 10-Gigabit Ethernet I/O module (either the N7K-M132XP-12 or N7K-M132XP-12L), connect each FEX to one port in a set of four shared ports on the module (you connect each set of shared ports to one FEX). If you are using the M2 Series 24-port, 10-Gigabit Ethernet I/O module (N7K-M224XP-23L), you can connect the FEX to any of its ports for a fully dedicated bandwidth. If you are using the F2 Series 48-port, 10-Gigabit Ethernet I/O module (N7K-F248XP-25), use the connectivity rule order (connect the same port numbers for each port group (for example, if you connect ports 1 and 2 of a port-group, then connect the same ports of another port group)).

For information about the transceivers and connectors that you can use with these ports, see the [“Transceivers Supported by the Cisco Nexus 2232PP FEX”](#) section on page 2-26.

Power Supplies for the Cisco Nexus 2232PP FEX

The Cisco Nexus 2200 Platform FEX chassis have two slots for front-end AC or DC power supplies that have port-side exhaust or port-side intake airflow. These chassis are fully functional with one power supply, but you can install a second power supply for power redundancy. You can install any of the following power supplies in those two bays:

- AC power supply with port-side exhaust airflow (N2200-PAC-400W)
- AC power supply with port-side intake airflow (N2200-PAC-400W-B)
- DC power supply with port-side exhaust airflow (N2200-PDC-400W)
- DC power supply with port-side intake airflow (N2200-PDC-350W-B)

**Caution**

Make sure that all of the fan tray and power supply modules use the same airflow direction and have the same color designation on the front. Otherwise, the switch can over heat and shut down,

For information on these power supplies, see the [“Power Supplies for the Cisco Nexus 2248TP FEX”](#) section on page 2-14 and the power supply specifications in the [“Technical Specifications”](#) section on page B-1.

Fan Tray for the Cisco Nexus 2232PP FEX

The Cisco Nexus 2232PP and 2232TM FEX use the same fan tray, which you can order with either port-side exhaust airflow (N2K-C2232-FAN) or port-side intake airflow (N2K-C2232-FAN-B).



Caution

Make sure that all of the fan tray and power supply modules use the same airflow direction and have the same color designation on the front. Otherwise, the switch can over heat and shut down,

For more information on this fan tray, see the “[Fan Tray for the Cisco Nexus 2232TM FEX](#)” section on [page 2-19](#) and the fan tray specifications in [Appendix B, “Technical Specifications”](#). For LED descriptions, see [Appendix E, “LEDs”](#).

Transceivers Supported by the Cisco Nexus 2232PP FEX

The Cisco Nexus 2232PP FEX supports SFP+ Ethernet optical and copper transceivers and optical FEX Transceivers (FETs) for up to eight fabric uplink connections to the following Cisco Nexus 7000 Series switch I/O modules:

- F2 Series 48-port 10-Gigabit I/O module (N7K-F248XP-25)
- M1 Series 32-port 10-Gigabit Ethernet I/O module (N7K-M132XP-12)
- M1 Series 32-port 10-Gigabit Ethernet I/O module with XL option (N7K-M132XP-12L)
- M2 Series 24-port 10-Gigabit I/O module (N7K-M224XP-23L)

You must use the same transceivers on both ends of the same uplink cable.



Note

To get the fully dedicated 10-Gbps bandwidth through a M1 Series 32-port 10-Gigabit Ethernet I/O module, connect each FEX to one port in a set of four shared ports on the module (you connect each set of shared ports to one FEX) and use the shared mode on the I/O module. If you are using the F2 Series 48-port 10-Gigabit Ethernet I/O module (N7K-F248XP-25) or the M2 Series 24-port 10-Gigabit Ethernet I/O module (N7K-M224XP-23L), you can connect the FEX to any of its ports.

The Cisco Nexus 2232TM FEX also supports RJ-45 connectors for up to 32 downlink connections to hosts. [Table 2-2](#) lists the transceivers supported by this FEX for its uplink and downlink connections.

Table 2-8 Supported Transceivers and Connector for the Cisco Nexus 2232TM FEX Uplink Interfaces

Transceiver or Connector	Cable Type	Fabric Interface (Uplink)	Host Interface (Downlink)	Comments
FET-10G	Optical	X	–	10 Gigabit FEX transceiver
GLC-LH-SM	Optical	–	X	Gigabit SFP transceiver
GLC-SX-MM	Optical	–	X	Gigabit SFP transceiver
GLC-T	Copper	–	X	Gigabit SFP transceiver
SFP-10G-LR	Optical	X	X	10 Gigabit long range transceiver (up to 6.2 miles [10 km])
SFP-10G-SR	Optical	X	X	10 Gigabit Short range transceiver (up to 984 feet [300 m])

Table 2-8 Supported Transceivers and Connector for the Cisco Nexus 2232TM FEX Uplink Interfaces

Transceiver or Connector	Cable Type	Fabric Interface (Uplink)	Host Interface (Downlink)	Comments
SFP-GE-L	Optical	–	X	Gigabit SFP transceiver
SFP-GE-S	Optical	–	X	Gigabit SFP transceiver
SFP-GE-T	Copper	–	X	Gigabit SFP transceiver
SFP -H10GB-CU1M ¹	Copper	X	X	10 Gigabit Twinax, passive transceiver (3.3 feet [1 meter])
SFP -H10GB-CU3M ¹	Copper	X	X	10 Gigabit Twinax, passive transceiver (9.8 feet [3 meters])
SFP -H10GB-CU5M ¹	Copper	X	X	10 Gigabit Twinax, passive transceiver (16.4 feet [5 meters])
SFP -H10GB-ACU7M	Copper	X	X	10 Gigabit Twinax, active transceiver (23.0 feet [7 meters])
SFP -H10GB-ACU10M	Copper	X	X	10 Gigabit Twinax, active transceiver (32.8 feet [10 meters])

1. The SFP-H10GB-CUxM transceivers are not supported by the M1 Series 32-port 10-Gigabit Ethernet I/O module (N7K-M132XP-12). These transceivers are supported by the other Cisco Nexus 7000 Series I/O modules.

[Figure 2-10 on page 2-10](#) shows the major features of the SFP+ optical transceiver used for uplink connections.

[Figure 2-11 on page 2-11](#) shows the major features of the SFP+ copper transceiver and cable used for uplink connections.

[Figure 2-12 on page 2-11](#) shows the major features of RJ-45 connectors, which are used for the downlink connections.

Cisco Nexus 2224TP FEX

The Cisco Nexus 2224TP FEX is a stackable Gigabit Ethernet FEX that has 24 100/1000BASE-T Ethernet host-facing (downlink) RJ-45 ports and two 10-Gigabit Ethernet network-facing (uplink) SFP+ ports. It requires a 19-inch (48.26 cm) rack for its installation. [Table 2-9](#) lists its physical characteristics.

Table 2-9 Physical Characteristics for the Cisco Nexus 2224TP FEX

Dimensions	
Width	17.3 inches (43.94 cm)
Depth	17.7 inches (44.96 cm)
Height	1.72 inches (4.37 cm)
Weight ¹	16.6 lb (7.53 kg)

1. Measured with two power supplies and one fan module installed.

You can order the Cisco Nexus 2224TP FEX with port-side exhaust or port-side intake airflow and with AC or DC power supplies. If you are going to install the port side in a hot aisle, then order port-side exhaust airflow for all of the fan trays and power supplies. If you are going to install the port side in the cold aisle, order port-side intake airflow for all of the fan trays and power supplies.

**Caution**

Make sure that all of the fan tray and power supply modules use the same airflow direction and have the same color designation on the front. Otherwise, the switch can over heat and shut down,

The front of the Cisco Nexus 2224TP FEX chassis has one or two power supplies, a fan tray, and two LEDs as shown in [Figure 2-24](#). This FEX model requires one power supply, but if you want power redundancy, you must install a second power supply.

Figure 2-24 Front View of the Cisco Nexus 2224TP Chassis

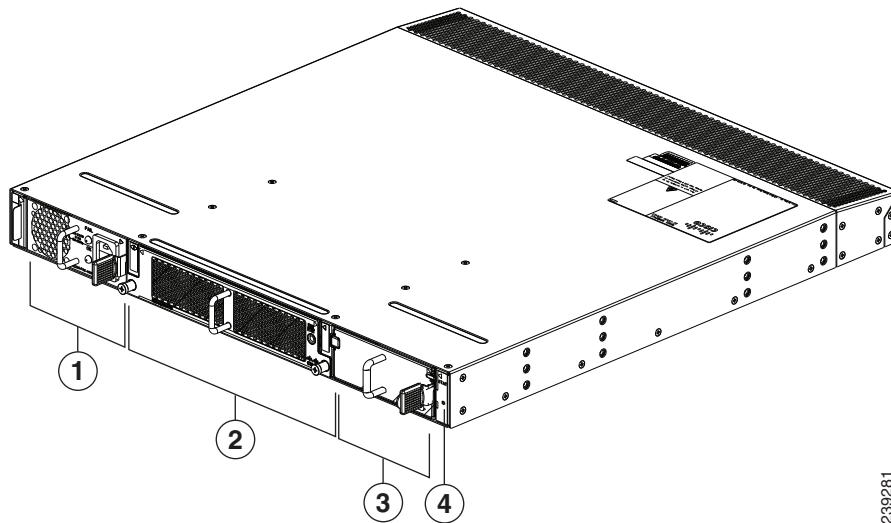

1	Power supply	3	Power supply (blank shown)
2	Fan tray	4	Status (top) and ID (bottom) LEDs

The rear of the Cisco Nexus 2224TP FEX has 24 100/1000 BASE-T Ethernet downlink ports, two 10-Gigabit Ethernet uplink ports, an HDMI port, and LEDs, as shown in [Figure 2-25](#).

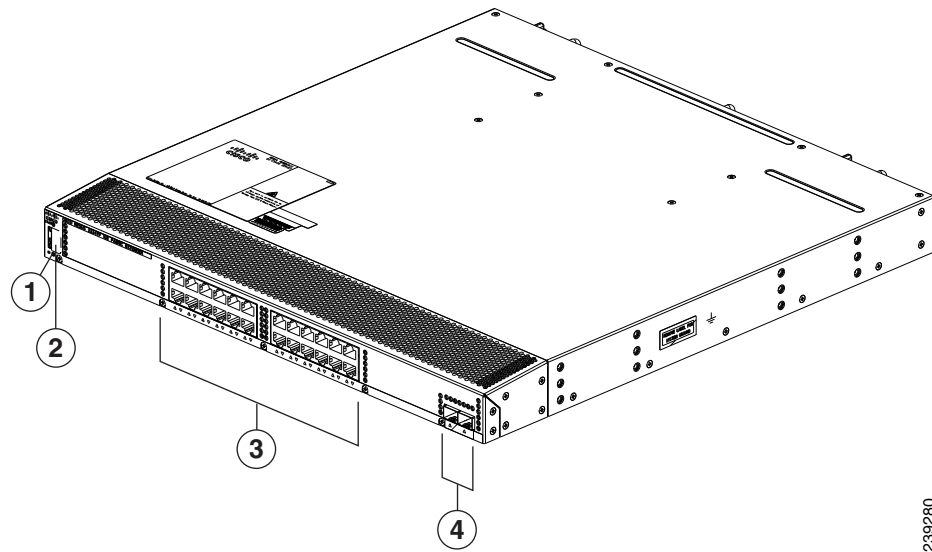
Figure 2-25 Rear View of the Cisco Nexus 2224TP Chassis

239280

1	Status (top) and ID (bottom) LEDs	3	100/1000 Ethernet downlink ports (24)
2	HDMI port	4	10-Gigabit Ethernet uplink ports (2)

For LED descriptions, see [Appendix E, “LEDs.”](#)

This section includes the following topics:

- [Ports for the Cisco Nexus 2224TP FEX, page 2-29](#)
- [Power Supplies for the Cisco Nexus 2224TP FEX, page 2-30](#)
- [Fan Tray for the Cisco Nexus 2224TP FEX, page 2-31](#)
- [Transceivers and Connectors Supported by the Cisco Nexus 2224TP FEX, page 2-31](#)

Ports for the Cisco Nexus 2224TP FEX

The downlink and uplink ports are numbered from top to bottom and then from left to right as shown in [Figure 2-26](#).

Figure 2-26 Port Numbering on the Cisco Nexus 2224TP FEX

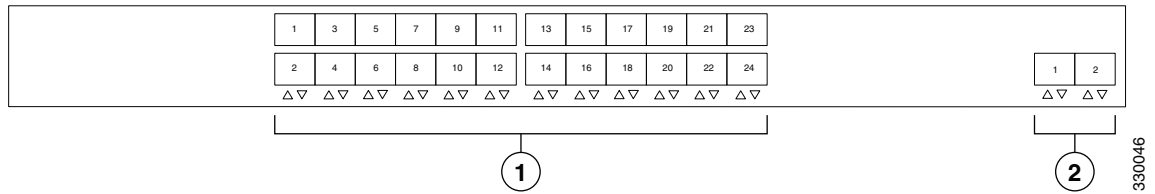

1	1- and 10-Gigabit Ethernet downlink ports, numbered 1 through 24	2	10-Gigabit Ethernet uplink ports, numbered 1 through 2
----------	--	----------	--

**Note**

For a fully dedicated 10-Gbps bandwidth through a M1 Series 32-port 10-Gigabit Ethernet I/O module (either the N7K-M132XP-12 or N7K-M132XP-12L), connect each FEX to one port in a set of four shared ports on the module (you connect each set of shared ports to one FEX). If you are using the M2 Series 24-port, 10-Gigabit Ethernet I/O module (N7K-M224XP-23L), you can connect the FEX to any of its ports for a fully dedicated bandwidth. If you are using the F2 Series 48-port, 10-Gigabit Ethernet I/O module (N7K-F248XP-25), use the connectivity rule order (connect the same port numbers for each port group (for example, if you connect ports 1 and 2 of a port-group, then connect the same ports of another port group)).

For information about the transceivers and connectors that you can use with these ports, see the [“Transceivers and Connectors Supported by the Cisco Nexus 2224TP FEX”](#) section on page 2-31.

Power Supplies for the Cisco Nexus 2224TP FEX

The Cisco Nexus 2200 Platform FEX chassis have two slots for front-end AC or DC power supplies that have port-side exhaust or port-side intake airflow. These chassis are fully functional with one power supply, but you can install a second power supply for power redundancy. You can install any of the following power supplies in those two bays:

- AC power supply with port-side exhaust airflow (N2200-PAC-400W)
- AC power supply with port-side intake airflow (N2200-PAC-400W-B)
- DC power supply with port-side exhaust airflow (N2200-PDC-400W)
- DC power supply with port-side intake airflow (N2200-PDC-350W-B)

**Caution**

Make sure that all of the fan tray and power supply modules use the same airflow and have the same color designation on the front. Otherwise, the switch can over heat and shut down,

For information on these power supplies, see the [“Power Supplies for the Cisco Nexus 2248TP FEX”](#) section on page 2-14 and the power supply specifications in [Appendix B, “Technical Specifications”](#).

Fan Tray for the Cisco Nexus 2224TP FEX

The Cisco Nexus 2224TP, 2248TP, and 2248TP-E FEXs use the same fan tray that you can order with either port-side exhaust airflow (N2K-C2248-FAN) or port-side intake airflow (N2K-C2248-FAN-B).



Caution

Make sure that all of the fan tray and power supply modules use the same airflow and have the same color designation on the front. Otherwise, the switch can over heat and shut down,

For information on this fan tray, see the “[Fan Tray for the Cisco Nexus 2248TP FEX](#)” section on [page 2-14](#) and the fan tray specifications in [Appendix B, “Technical Specifications”](#). For LED descriptions, see [Appendix E, “LEDs”](#).

Transceivers and Connectors Supported by the Cisco Nexus 2224TP FEX

The Cisco Nexus 2224TP FEX supports SFP+ Ethernet optical and copper transceivers and optical FEX Transceivers (FETs) for up to four fabric uplink connections to Cisco Nexus 7000 Series switches, and it supports RJ-45 connectors for up to 48 downlink connections to hosts. For each uplink cable, you must use the same transceiver on both ends. [Table 2-2](#) lists the transceivers supported by this FEX for its uplink fabric.

Table 2-10 Supported Transceivers and Connector for the Cisco Nexus 2224TP FEX Uplink Interfaces

Transceiver or Connector	Cable Type	Fabric Interface (Uplink)	Host Interface (Downlink)	Comments
FET-10G	Optical	X	–	10 Gbps FEX transceiver
SFP-10G-LR	Optical	X	–	10 Gbps long range transceiver (up to 6.2 miles [10 km])
SFP-10G-SR	Optical	X	–	10 Gbps Short range transceiver (up to 984 feet [300 m])
SFP -H10GB-CU1M	Copper	X	–	10 Gbps Twinax, passive transceiver (3.3 feet [1 meter])
SFP -H10GB-CU3M	Copper	X	–	10 Gbps Twinax, passive transceiver (9.8 feet [3 meters])
SFP -H10GB-CU5M	Copper	X	–	10 Gbps Twinax, passive transceiver (16.4 feet [5 meters])
SFP -H10GB-ACU7M	Copper	X	–	10 Gbps Twinax, active transceiver (23.0 feet [7 meters])
SFP -H10GB-ACU10M	Copper	X	–	10 Gbps Twinax, active transceiver (32.8 feet [10 meters])
RJ-45	Copper	–	X	100/1000 Mbps Connector

[Figure 2-10 on page 2-10](#) shows the SFP+ optical transceiver used for uplink connections.

[Figure 2-11 on page 2-11](#) identifies the major features of the SFP+ copper transceiver and cable used for uplink connections.

[Figure 2-12 on page 2-11](#) identifies the major features of RJ-45 connectors, which are used for the downlink connections.



Using a Fabric Extender with a Cisco Nexus 9000 Series Switch

This chapter describes the Cisco Nexus 2200 Platform Fabric Extender (FEX) chassis and the components that you can connect to a Cisco Nexus 9000 Series switch.

This chapter includes the following sections:

- [Information About Using a Fabric Extender with a Cisco Nexus 9396PX Switch, page 3-1](#)
- [Cisco Nexus 2248TP-E FEX, page 3-1](#)
- [Cisco Nexus 2248TP FEX, page 3-10](#)
- [Cisco Nexus 2232TM FEX, page 3-15](#)
- [Cisco Nexus 2232PP FEX, page 3-21](#)
- [Cisco Nexus 2224TP FEX, page 3-25](#)

Information About Using a Fabric Extender with a Cisco Nexus 9396PX Switch

With Cisco NX-OS Release 6.1(2)I2(3) and later releases, you can extend the Cisco Nexus 9396PX switch architecture by connecting up to six FEXs as remote I/O modules. Depending on which FEX model that you connect to the switch, the FEX provides top-of-the-rack connectivity for up to 48, 32, or 24 hosts, and it becomes an extension of the parent Cisco Nexus 9396PX switch fabric, with the FEX and the switch becoming a virtual modular system. The FEX forwards all 100/1000 Ethernet or 1- and 10-Gigabit Ethernet traffic from the hosts to the switch over 10-Gbps uplinks. Traffic flows from the switch to the FEX over the 10-Gbps uplinks and to the individual hosts over 100/1000 Ethernet or 1- and 10-Gigabit Ethernet downlinks.

Cisco Nexus 2248TP-E FEX

The Cisco Nexus 2248TP-E FEX (N2K-C2248TP-E) is a stackable 1-RU FEX that has 48 100/1000 Ethernet host interfaces (downlink ports for copper RJ-45 connectors) and four 10-Gigabit Ethernet fabric interfaces (uplink ports for copper/optical SFP+ connectors). This FEX requires a 19-inch (48.26-cm) rack for its installation. [Table 3-1](#) lists its physical characteristics.

Table 3-1 Physical Characteristics for the Cisco Nexus 2248TP-E FEX

Dimensions	
Width	17.3 inches (43.9 cm)
Depth	20.0 inches (50.8 cm)
Height	1.72 inches (4.4 cm)
<hr/>	
Weight ¹	17.7 lb (8.0 kg)

1. Measured with two power supplies and one fan module installed.

You can order the Cisco Nexus 2248TP-E FEX with port-side exhaust or port-side intake airflow and with AC or DC power supplies. If you are going to install the port side in a hot aisle, then order port-side-exhaust airflow for all of the fan trays and power supplies. If you are going to install the port side in the cold aisle, order port-side-intake airflow for all of the fan trays and power supplies.

**Note**

For visual identification, port-side-intake airflow power supplies and fan trays have a black stripe across their front, and port-side-exhaust airflow modules do not have a black stripe across their front. All of the power supplies and fan trays must have the same direction of airflow for the components to properly function (all of these components must either have a black stripe or all of the components must not have a black stripe).

The front of the Cisco Nexus 2248TP-E FEX chassis has one or two power supplies, a fan tray, and two chassis LEDs as shown in [Figure 3-1](#). This FEX model requires one power supply, but if you want power redundancy, you must install a second power supply.

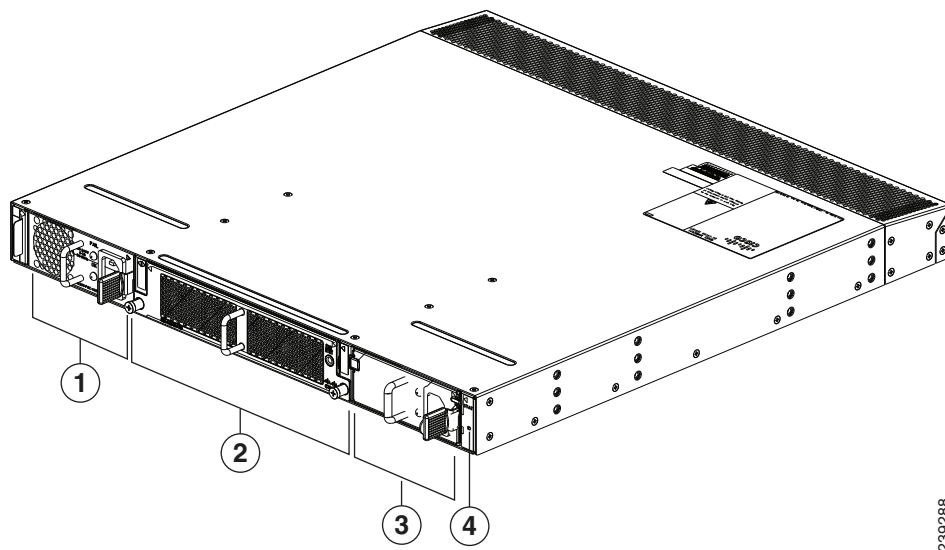
Figure 3-1 Front View of the Cisco Nexus 2248TP-E Chassis

1	Power supply	3	Power supply (blank shown)
2	Fan tray	4	Status (top) and ID (bottom) LEDs

The rear of the Cisco Nexus 2248TP-E FEX chassis has 48 100/1000 Ethernet downlink ports, four 10-Gigabit Ethernet uplink ports, an HDMI port, and LEDs, as shown in [Figure 3-2](#).

Figure 3-2 Rear View of the Cisco Nexus 2248TP-E Chassis

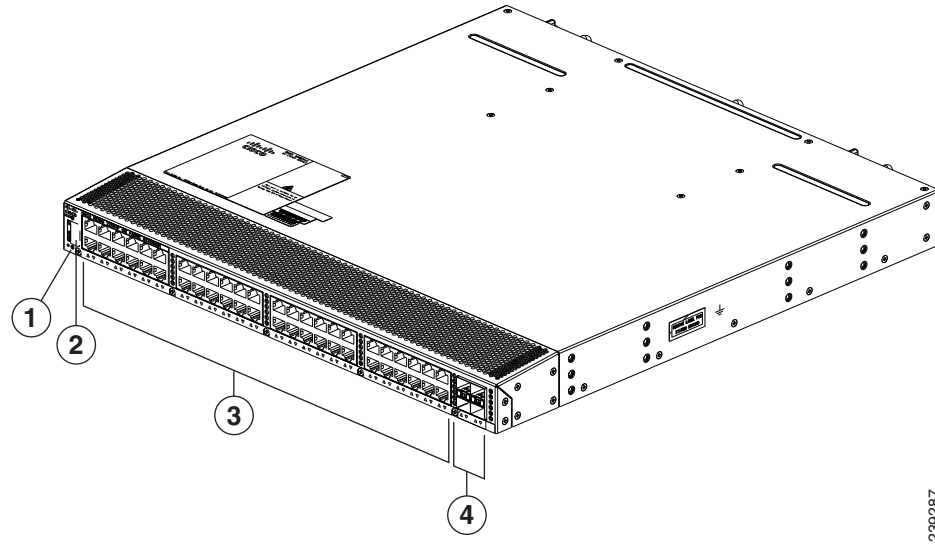

1	Status (top) and ID (bottom) LEDs	3	100/1000BASE-T Ethernet ports (copper downlink ports for RJ-45 connectors) (48)
2	HDMI port	4	10-Gigabit Ethernet fabric ports (copper/optical uplink ports for SFP+ transceivers) (4)

For LED descriptions, see [Appendix E, “LEDs.”](#)

This section includes the following topics:

- [Ports for the Cisco Nexus 2248TP-E FEX, page 3-3](#)
- [Power Supplies for the Cisco Nexus 2248TP-E FEX, page 3-4](#)
- [Fan Tray for the Cisco Nexus 2248TP-E FEX, page 3-6](#)
- [Transceivers and Connectors Supported by the Cisco Nexus 2248TP-E FEX, page 3-8](#)

Ports for the Cisco Nexus 2248TP-E FEX

The downlink and uplink ports are numbered from top to bottom and then left to right as shown in [Figure 3-3](#).

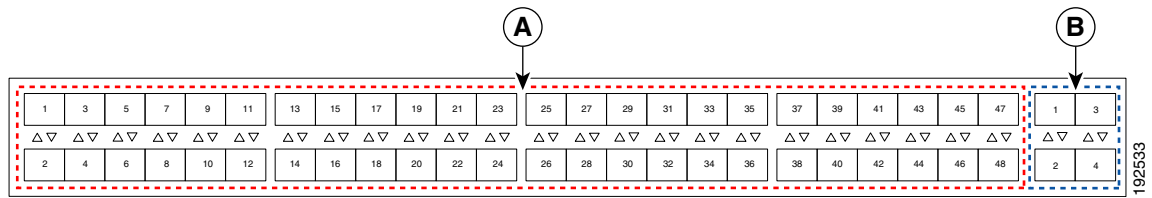
Figure 3-3 Port Numbering on the Cisco Nexus 2248TP-E FEX

A	100/1000BASE-T Ethernet downlink ports, numbered 1 through 48	B	10-Gigabit Ethernet uplink ports, numbered 1 through 4
----------	---	----------	--

For information about the transceivers and connectors that you can use with these ports, see the [“Transceivers and Connectors Supported by the Cisco Nexus 2248TP-E FEX”](#) section on page 3-8.

Power Supplies for the Cisco Nexus 2248TP-E FEX

The Cisco Nexus 2200 Series FEX chassis have two slots for front-end AC or DC power supplies that have port-side-exhaust or port-side-intake airflow. These chassis are fully functional with one power supply, but you can install a second power supply for power redundancy. If you have only one power supply in the chassis, install a blank filler panel (N2200-P-BLNK) to maintain the designed airflow in the chassis. You can install any of the following power supplies in those two bays:

- AC power supply with port-side-exhaust airflow (N2200-PAC-400W)
- AC power supply with port-side-intake airflow (N2200-PAC-400W-B)
- DC power supply with port-side-exhaust airflow (N2200-PDC-400W)
- DC power supply with port-side-intake airflow (N2200-PDC-350W-B)



Caution

Make sure that all of the fan tray and power supply modules use the same airflow direction and have the same color designation on the front. Otherwise, the switch can over heat and shut down,

[Figure 3-4](#) shows the exterior components on an AC power supply with port-side-exhaust airflow (no black stripe on the front). [Figure 3-5](#) shows the components on a DC power supply with port-side-exhaust airflow. [Figure 3-6](#) shows the black stripe used to indicate port-side-intake airflow (in this case on an AC power supply). [Figure 3-7](#) shows the blank filler panel that you should install in an open power supply slot if the chassis has only one power supply.

Figure 3-4 AC Power Supply with Port-Side-Exhaust Airflow for the Cisco Nexus 2200 Platform

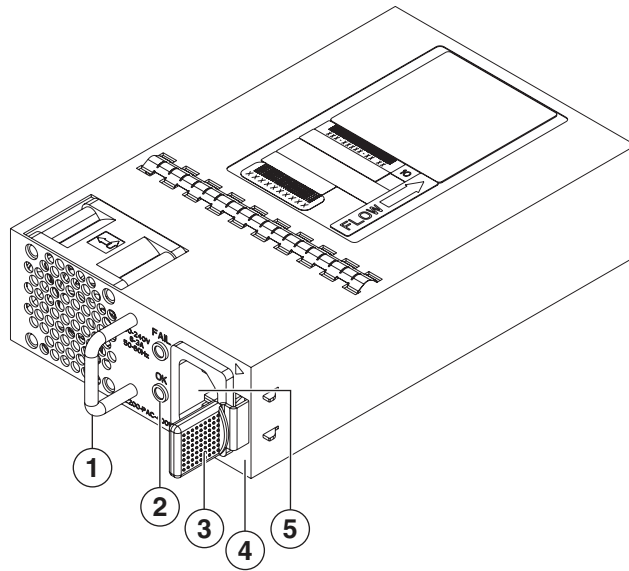

1	Handle	4	No black stripe (port-side-exhaust airflow)
2	FAIL (top) and OK (bottom) LEDs	5	AC power receptacle
3	Ejector latch		

Figure 3-5 DC Power Supply with Front-to-Back Airflow for the Cisco Nexus 2200 Platform

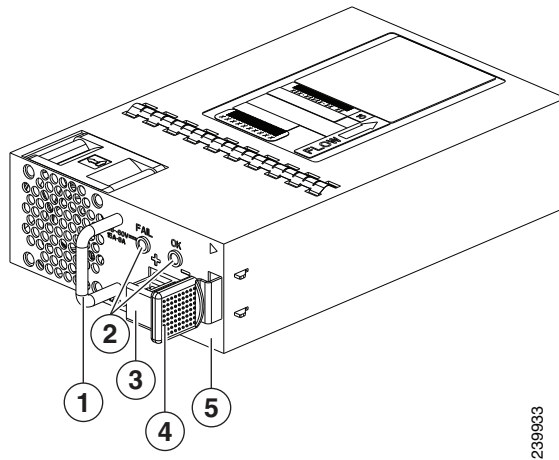

1	Handle	4	Ejector latch
2	FAIL (left) and OK (right) LEDs	5	No black stripe (port-side-exhaust airflow)
3	DC power connector with safety cover		

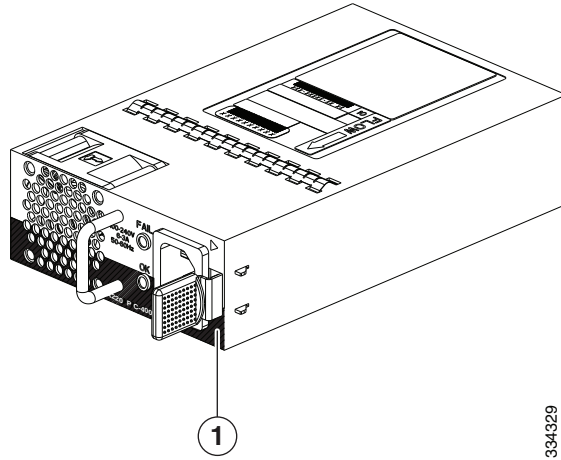
Figure 3-6 Black Stripe Used to Indicate Port-Side-Intake Airflow

1	Black stripe (port-side-intake airflow)
----------	---

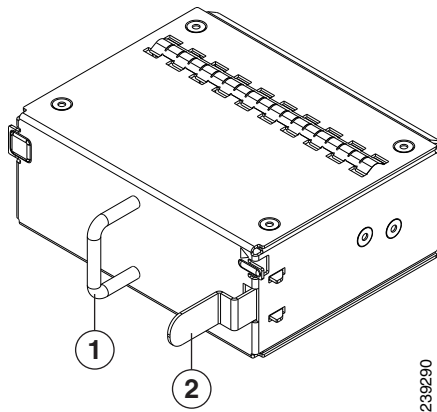
Figure 3-7 Blank Power Supply Filler Panel for a Cisco Nexus 2200 Platform Power Supply Bay

1	Handle	2	Ejector latch
----------	--------	----------	---------------

For LED descriptions, see [Appendix E, “LEDs”](#).

For power supply specifications, see the [Appendix B, “Technical Specifications”](#).

Fan Tray for the Cisco Nexus 2248TP-E FEX

The Cisco Nexus 2224TP, 2248TP, and 2248TP-E FEXs use the same fan tray that you can order with either port-side-exhaust airflow (N2K-C2248-FAN) or port-side-intake airflow (N2K-C2248-FAN-B). The fan tray includes a status LED that indicates whether the module is operational.



Caution

Make sure that all of the fan tray and power supply modules use the same airflow direction and have the same color designation on the front. Otherwise, the switch can over heat and shut down,

Figure 3-8 shows the fan tray with port-side-exhaust airflow (no black stripe on front) and identifies its components, and Figure 3-9 shows the fan tray with port-side-intake airflow (black stripe on front) and identifies its components.

Figure 3-8 Port-Side-Exhaust Airflow Fan Tray for the Cisco Nexus 2000 Series FEX

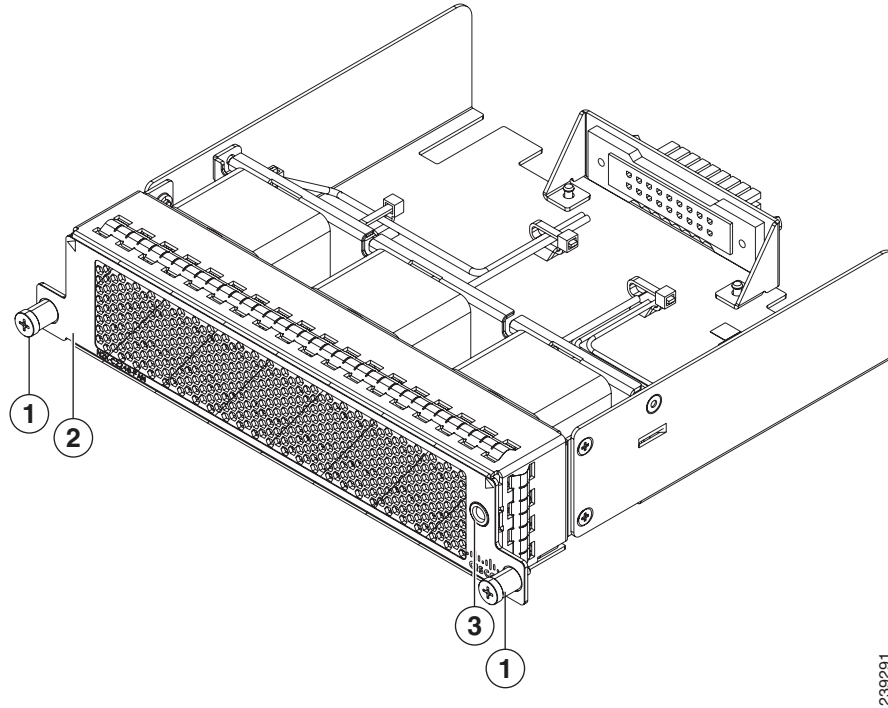

1	Captive screws (2)	3	Status LED
2	No black stripe on the front indicates that this fan tray has port-side-exhaust airflow.		

Figure 3-9 Port-Side Intake Airflow Fan Tray for the Cisco Nexus 2000 Series FEX

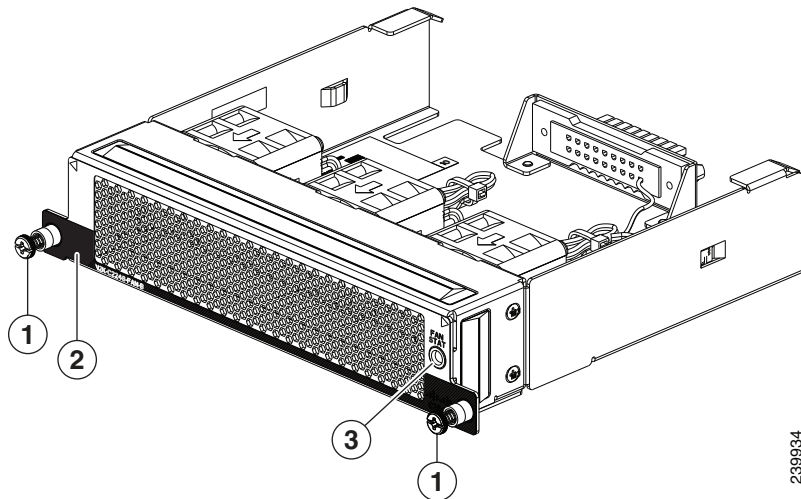

1	Captive screws (2)	3	Status LED
2	Black stripe on the front indicates that this fan tray has port-side intake airflow.		

For information on this fan tray, see the “Fan Tray for the Cisco Nexus 2248TP FEX” section on page 3-13 and the fan tray specifications in Appendix B, “Technical Specifications”. For LED descriptions, see Appendix E, “LEDs”.

Transceivers and Connectors Supported by the Cisco Nexus 2248TP-E FEX

The Cisco Nexus 2248TP-E FEX supports SFP+ Ethernet copper and optical transceivers for up to four fabric uplink connections to Cisco Nexus 9396PX switches, and it supports 100/1000BASE-T RJ-45 connectors for up to 48 downlink connections to hosts. Table 3-2 lists the transceivers supported by this FEX for its uplink and downlink connections.

Table 3-2 Supported Transceivers and Connector for the Cisco Nexus 2248TP-E FEX Interfaces

Transceiver or Connector	Cable Type	Fabric Interface (Uplink)	Host Interface (Downlink)	Comments
FET-10G	Optical	X	–	10-Gbps FEX transceiver
SFP-10G-LR	Optical	X	–	10-Gbps long range transceiver (up to 6.2 miles [10 km])
SFP-10G-SR	Optical	X	–	10-Gbps Short range transceiver (up to 984 feet [300 m])
SFP -H10GB-CU1M	Copper	X	–	10-Gbps Twinax, passive transceiver (3.3 feet [1 meter])
SFP -H10GB-CU3M	Copper	X	–	10-Gbps Twinax, passive transceiver (9.8 feet [3 meters])
SFP -H10GB-CU5M	Copper	X	–	10-Gbps Twinax, passive transceiver (16.4 feet [5 meters])
SFP -H10GB-ACU7M	Copper	X	–	10-Gbps Twinax, active transceiver (23.0 feet [7 meters])
SFP -H10GB-ACU10M	Copper	X	–	10-Gbps Twinax, active transceiver (32.8 feet [10 meters])
SFP-10G-AOC1M	Optical	X	–	10-Gbps active optical cable (3.3 feet [1 meter])
SFP-10G-AOC2M	Optical	X	–	10-Gbps active optical cable (6.6 feet [2 meters])
SFP-10G-AOC3M	Optical	X	–	10-Gbps active optical cable (9.8 feet [3 meters])
SFP-10G-AOC5M	Optical	X	–	10-Gbps active optical cable (16.4 feet [5 meters])
SFP-10G-AOC7M	Optical	X	–	10-Gbps active optical cable (23.0 feet [7 meters])
SFP-10G-AOC10M	Optical	X	–	10-Gbps active optical cable (32.8 feet [10 meters])
QSFP-4X10G-AOC1M	Optical	X	–	40- and 10-Gbps active optical breakout cable (3.3 feet [1 meter])
QSFP-4X10G-AOC2M	Optical	X	–	40- and 10-Gbps active optical breakout cable (6.6 feet [2 meters])
QSFP-4X10G-AOC3M	Optical	X	–	40- and 10-Gbps active optical breakout cable (9.8 feet [3 meters])

Table 3-2 Supported Transceivers and Connector for the Cisco Nexus 2248TP-E FEX Interfaces

Transceiver or Connector	Cable Type	Fabric Interface (Uplink)	Host Interface (Downlink)	Comments
QSFP-4X10G-AOC5M	Optical	X	–	40- and 10-Gbps active optical breakout cable (16.4 feet [5 meters])
QSFP-4X10G-AOC7M	Optical	X	–	40- and 10-Gbps active optical breakout cable (23.0 feet [7 meters])
QSFP-4X10G-AOC10M	Optical	X	–	40- and 10-Gbps active optical breakout cable (32.8 feet [10 meters])
QSFP-4SFP10G-CU1M	Optical	X	–	40- and 10-Gbps copper breakout cable (3.3 feet [1 meter])
QSFP-4SFP10G-CU3M	Optical	X	–	40- and 10-Gbps copper breakout cable (9.8 feet [3 meters])
QSFP-4SFP10G-CU5M	Optical	X	–	40- and 10-Gbps copper breakout cable (16.4 feet [5 meters])
QSFP-4SFP10G-CU7M	Optical	X	–	40- and 10-Gbps copper breakout cable (23.0 feet [7 meters])
QSFP-4SFP10G-CU10M	Optical	X	–	40- and 10-Gbps copper breakout cable (32.8 feet [10 meters])
RJ-45	Copper	–	X	100/1000 Mbps Connector

For more information on the transceivers that you can use with this FEX, see the *Cisco Transceiver Modules Compatibility Information* at <http://www.cisco.com/c/en/us/support/interfaces-modules/transceiver-modules/products-device-support-tables-list.html>.

Figure 3-10 shows the SFP+ optical transceiver used for uplink connections.

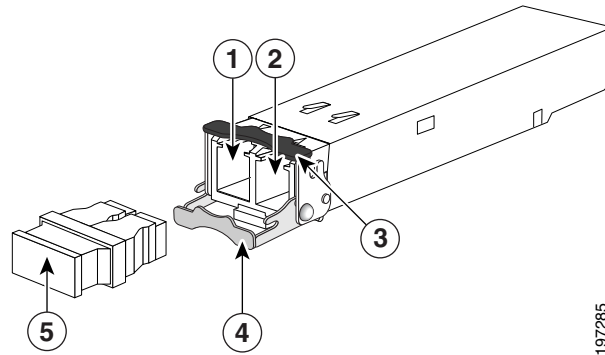
Figure 3-10 SFP+ Optical Transceivers and FETs

1	Receive optical bore	4	Clasp shown in open position
2	Transmit optical bore	5	Dust plug (use this to protect the bores from dust contamination when the optical cables are removed)
3	Clasp shown in closed position		

Figure 3-11 identifies the major features of the SFP+ copper transceiver and cable used for uplink connections. For the cable specifications that apply to these transceivers, see Appendix C, “Cable and Port Specifications”.

Figure 3-11 SFP+ Copper Transceiver Module

Figure 3-12 identifies the major features of RJ-45 connectors, which are used for the downlink connections.

Figure 3-12 RJ-45 Connector

1	Pin 1	2	Pin 8
----------	-------	----------	-------

Cisco Nexus 2248TP FEX

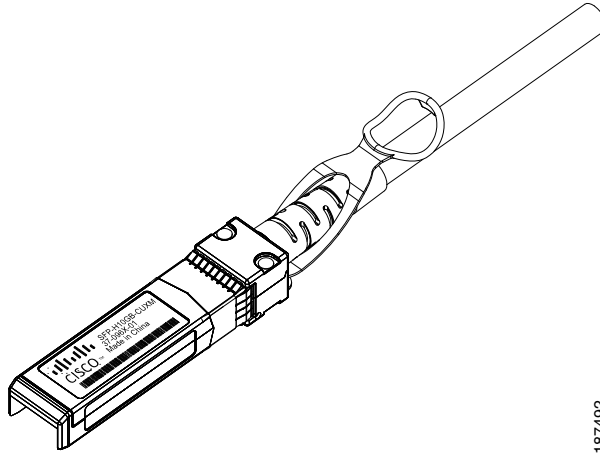
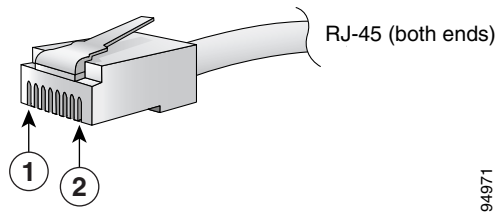
The Cisco Nexus 2248TP FEX (N2K-C2248TP) is a stackable 1-RU FEX that has 48 100/1000 Ethernet host interfaces (downlink ports for copper RJ-45 connectors) and four 10-Gigabit Ethernet fabric interfaces (uplink ports for copper/optical SFP+ transceivers). It requires a 19-inch (48.26-cm) rack for its installation. Table 3-3 lists its physical characteristics.

Table 3-3 Physical Characteristics for the Cisco Nexus 2248TP FEX

Dimensions	
Width	17.3 inches (43.9 cm)
Depth	20.0 inches (50.8 cm)
Height	1.72 inches (4.4 cm)
Weight ¹	
	17.7 lb (8.0 kg)

1. Measured with two power supplies and one fan module installed.

You can order the Cisco Nexus 2248TP FEX with front-to-back (port-side exhaust) or back-to-front (port-side intake) airflow and with AC or DC power supplies. If you are going to install the port side in a hot aisle, then order port-side-exhaust airflow for the fan trays and power supplies. If you are going to install the port side in the cold aisle, order port-side-intake airflow for the fan trays and power supplies.



Note

For visual identification, port-side-intake airflow fan trays and power supplies have a black stripe across their front, and port-side-exhaust airflow modules do not have a black stripe across their front. All of the power supplies and fan trays must have the same direction of airflow for the components to properly function (all of these components must either have a black stripe or all of the components must not have a black stripe).

The front of the Cisco Nexus 2248TP FEX chassis has one or two power supplies, a fan tray, and two chassis LEDs as shown in [Figure 3-13](#). This FEX model requires one power supply, but if you want power redundancy, you must install a second power supply.

Figure 3-13 Front View of the Cisco Nexus 2248TP Chassis

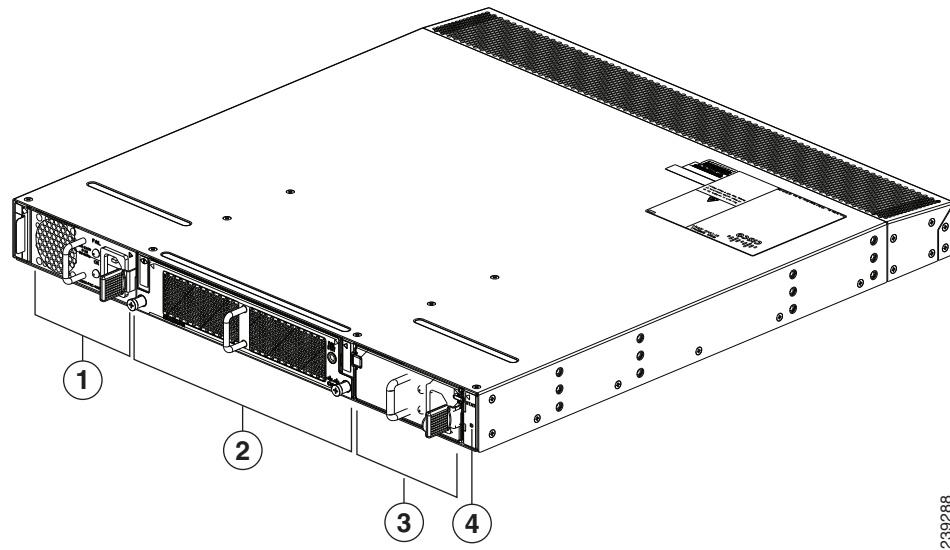

1	Power supply	3	Power supply (blank shown)
2	Fan tray	4	Status (top) and ID (bottom) LEDs

The rear of the Cisco Nexus 2248TP-E FEX has 48 100/1000 Ethernet downlink ports, four 10-Gigabit Ethernet uplink ports, an HDMI port, and LEDs, as shown in [Figure 3-14](#).

Figure 3-14 Rear View of the Cisco Nexus 2248TP Chassis

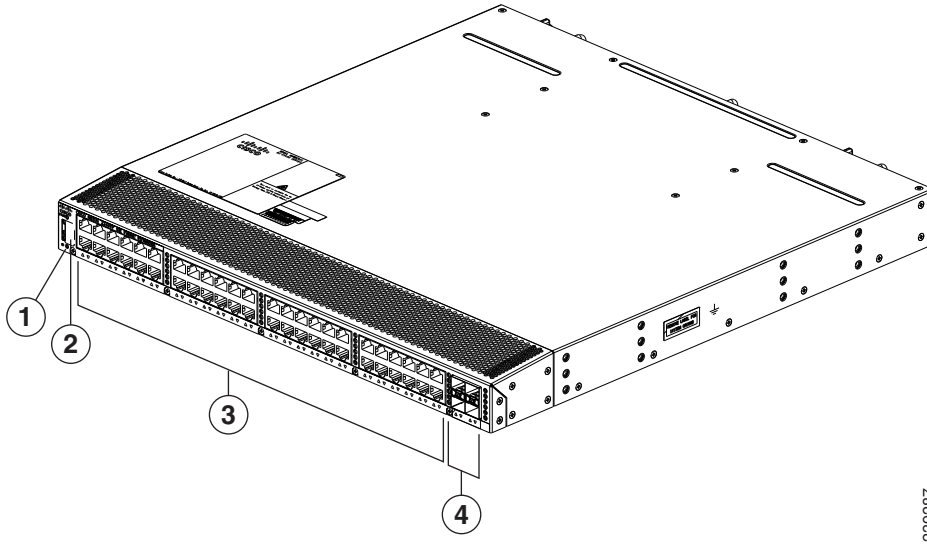

239287

1	Status (top) and ID (bottom) LEDs	3	100/1000 BASE-T host-facing (downlink) ports (48)
2	HDMI port	4	10-Gigabit SFP+ network-facing (uplink) ports (4)

For LED descriptions, see [Appendix E, “LEDs”](#).

This section includes the following topics:

- [Ports for the Cisco Nexus 2248TP FEX, page 3-12](#)
- [Power Supplies for the Cisco Nexus 2248TP FEX, page 3-13](#)
- [Fan Tray for the Cisco Nexus 2248TP FEX, page 3-13](#)
- [Transceivers and Connectors Supported by the Cisco Nexus 2248TP FEX, page 3-13](#)

Ports for the Cisco Nexus 2248TP FEX

The downlink and uplink ports are numbered from top to bottom and then left to right as shown in [Figure 3-15](#).

Figure 3-15 Port Numbering on the Cisco Nexus 2248TP FEX

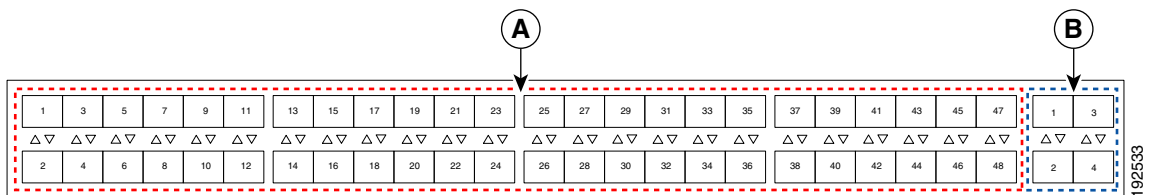

A	100/1000BASE-T Ethernet ports, numbered 1 through 48	B	10-Gigabit SFP+ Ethernet uplink ports, numbered 1 through 4
----------	--	----------	---

For information about the transceivers and connectors that you can use with these ports, see the [“Transceivers and Connectors Supported by the Cisco Nexus 2248TP FEX”](#) section on page 3-13.

Power Supplies for the Cisco Nexus 2248TP FEX

The Cisco Nexus 2200 Platform FEX chassis have two slots for front-end AC or DC power supplies that have port-side-exhaust or port-side-intake airflow. These chassis are fully functional with one power supply, but you can install a second power supply for power redundancy. You can install any of the following power supplies in those two bays:

- AC power supply with port-side-exhaust airflow (N2200-PAC-400W)
- AC power supply with port-side-intake airflow (N2200-PAC-400W-B)
- DC power supply with port-side-exhaust airflow (N2200-PDC-400W)
- DC power supply with port-side-intake airflow (N2200-PDC-350W-B)

**Caution**

Make sure that all of the fan tray and power supply modules use the same airflow direction and have the same color designation on the front. Otherwise, the switch can over heat and shut down,

For information on these power supplies, see the [“Power Supplies for the Cisco Nexus 2248TP FEX”](#) section on page 3-13 and the power supply specifications in the [Appendix B, “Technical Specifications”](#).

Fan Tray for the Cisco Nexus 2248TP FEX

The Cisco Nexus 2224TP, 2248TP, and 2248TP-E FEXs use the same fan tray that you can order with either port-side-exhaust airflow (N2K-C2248-FAN) or port-side-intake airflow (N2K-C2248-FAN-B).

**Caution**

Make sure that all of the fan tray and power supply modules use the same airflow direction and have the same color designation on the front. Otherwise, the switch can over heat and shut down,

For information on this fan tray, see the [“Fan Tray for the Cisco Nexus 2248TP-E FEX”](#) section on page 3-6 and the fan tray specifications in [Appendix B, “Technical Specifications”](#). For LED descriptions, see [Appendix E, “LEDs”](#).

Transceivers and Connectors Supported by the Cisco Nexus 2248TP FEX

The Cisco Nexus 2248TP FEX supports SFP+ Ethernet copper and optical transceivers for up to four fabric uplink connections to Cisco Nexus 9396PX switches, and it supports 100/1000BASE-T RJ-45 connectors for up to 48 downlink connections to hosts. For each uplink cable, you must use the same transceiver on both ends. [Table 3-2](#) lists the transceivers supported by this FEX for its uplink fabric.

Table 3-4 Supported Transceivers and Connector for the Cisco Nexus 2248TP FEX Interfaces

Transceiver or Connector	Cable Type	Fabric Interface (Uplink)	Host Interface (Downlink)	Comments
FET-10G	Optical	X	–	10-Gbps FEX transceiver
SFP-10G-LR	Optical	X	–	10-Gbps long range transceiver (up to 6.2 miles [10 km])
SFP-10G-SR	Optical	X	–	10-Gbps Short range transceiver (up to 984 feet [300 m])
SFP -H10GB-CU1M	Copper	X	–	10-Gbps Twinax, passive transceiver (3.3 feet [1 meter])
SFP -H10GB-CU3M	Copper	X	–	10-Gbps Twinax, passive transceiver (9.8 feet [3 meters])
SFP -H10GB-CU5M	Copper	X	–	10-Gbps Twinax, passive transceiver (16.4 feet [5 meters])
SFP -H10GB-ACU7M	Copper	X	–	10-Gbps Twinax, active transceiver (23.0 feet [7 meters])
SFP -H10GB-ACU10M	Copper	X	–	10-Gbps Twinax, active transceiver (32.8 feet [10 meters])
SFP-10G-AOC1M	Optical	X	–	10-Gbps active optical cable (3.3 feet [1 meter])
SFP-10G-AOC2M	Optical	X	–	10-Gbps active optical cable (6.6 feet [2 meters])
SFP-10G-AOC3M	Optical	X	–	10-Gbps active optical cable (9.8 feet [3 meters])
SFP-10G-AOC5M	Optical	X	–	10-Gbps active optical cable (16.4 feet [5 meters])
SFP-10G-AOC7M	Optical	X	–	10-Gbps active optical cable (23.0 feet [7 meters])
SFP-10G-AOC10M	Optical	X	–	10-Gbps active optical cable (32.8 feet [10 meters])
QSFP-4X10G-AOC1M	Optical	X	–	40- and 10-Gbps active optical breakout cable (3.3 feet [1 meter])
QSFP-4X10G-AOC2M	Optical	X	–	40- and 10-Gbps active optical breakout cable (6.6 feet [2 meters])
QSFP-4X10G-AOC3M	Optical	X	–	40- and 10-Gbps active optical breakout cable (9.8 feet [3 meters])
QSFP-4X10G-AOC5M	Optical	X	–	40- and 10-Gbps active optical breakout cable (16.4 feet [5 meters])
QSFP-4X10G-AOC7M	Optical	X	–	40- and 10-Gbps active optical breakout cable (23.0 feet [7 meters])
QSFP-4X10G-AOC10M	Optical	X	–	40- and 10-Gbps active optical breakout cable (32.8 feet [10 meters])
QSFP-4SFP10G-CU1M	Optical	X	–	40- and 10-Gbps copper breakout cable (3.3 feet [1 meter])
QSFP-4SFP10G-CU3M	Optical	X	–	40- and 10-Gbps copper breakout cable (9.8 feet [3 meters])
QSFP-4SFP10G-CU5M	Optical	X	–	40- and 10-Gbps copper breakout cable (16.4 feet [5 meters])
QSFP-4SFP10G-CU7M	Optical	X	–	40- and 10-Gbps copper breakout cable (23.0 feet [7 meters])
QSFP-4SFP10G-CU10M	Optical	X	–	40- and 10-Gbps copper breakout cable (32.8 feet [10 meters])
RJ-45	Copper	–	X	100/1000 Mbps Connector

For more information on the transceivers that you can use with this FEX, see the *Cisco Transceiver Modules Compatibility Information* at <http://www.cisco.com/c/en/us/support/interfaces-modules/transceiver-modules/products-device-support-tables-list.html>.

[Figure 3-10 on page 3-9](#) shows the SFP+ optical transceiver used for uplink connections.

[Figure 3-11 on page 3-10](#) identifies the major features of the SFP+ copper transceiver and cable used for uplink connections.

[Figure 3-12 on page 3-10](#) identifies the major features of RJ-45 connectors, which are used for the downlink connections.

Cisco Nexus 2232TM FEX

The Cisco Nexus 2232TM FEX (N2K-C2232TM) is a stackable 1-RU FEX that has 32 1- and 10-Gigabit Ethernet host interfaces (1/10GBASE-T downlink ports for RJ-45 connectors) and eight 10-Gigabit Ethernet fabric interfaces (copper/optical uplink ports for SFP+ transceivers). It requires a 19-inch (48.26-cm) rack for its installation. [Table 3-7](#) lists its physical characteristics.

Table 3-5 Physical Characteristics for the Cisco Nexus 2232TM FEX

Dimensions	
Width	17.3 inches (43.94 cm)
Depth	17.7 inches (44.96 cm)
Height	1.72 inches (4.37 cm)
Weight ¹	
	18.3 lb (8.3 kg)

1. Measured with two power supplies and one fan module installed

You can order the Cisco Nexus 2232TM with port-side exhaust or port-side-intake airflow and with AC or DC power supplies. If you are going to install the port side in a hot aisle, then order port-side exhaust airflow for the fan trays and power supplies. If you are going to install the port side in the cold aisle, order port-side intake airflow for the fan trays and power supplies.

The front of the Cisco Nexus 2232TM FEX chassis has one or two power supplies, a fan tray, and two LEDs as shown in [Figure 3-16](#). This FEX model requires one power supply, but if you want power redundancy, you must install a second power supply.

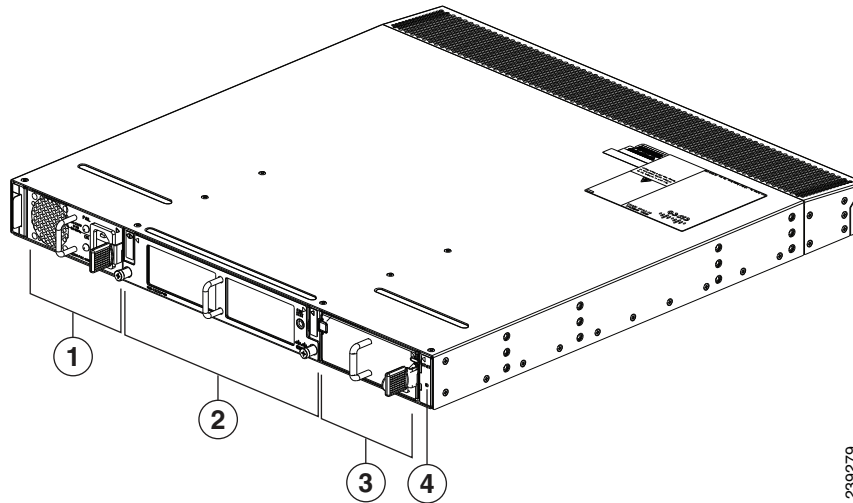
Figure 3-16 Front View of the Cisco Nexus 2232TM Chassis

1	Power supply	3	Power supply (blank shown)
2	Fan tray	4	Status (top) and ID (bottom) LEDs

The rear of the Cisco Nexus 2232TM FEX has 32 1- and 10-Gigabit Ethernet downlink ports, eight 10-Gigabit Ethernet uplink ports, an HDMI port, and two LEDs, as shown in [Figure 3-22](#).

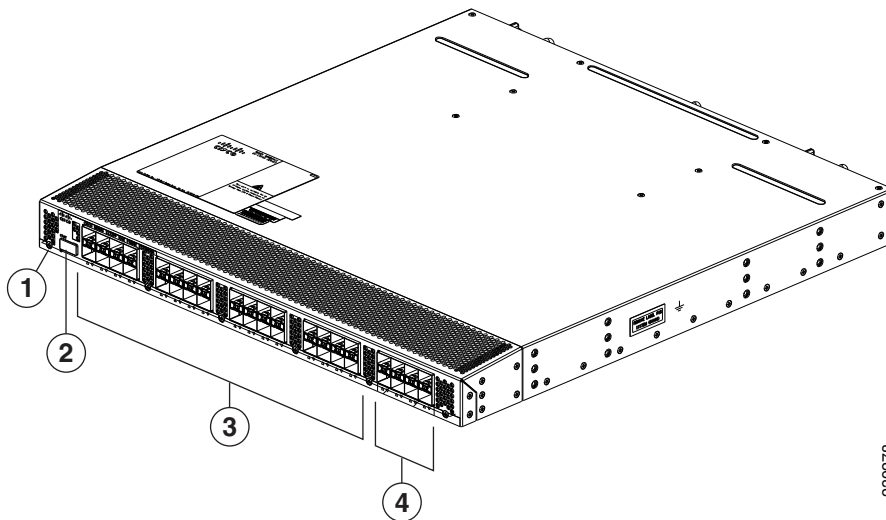
Figure 3-17 Rear View of the Cisco Nexus 2232TM Chassis

1	Status (top) and ID (bottom) LEDs	3	1- and 10-Gigabit Ethernet host ports (1/10GBASE-T downlink ports for RJ-45 connectors) (48)
2	HDMI port	4	10-Gigabit Ethernet fabric ports (copper/optical uplink ports for SFP+ transceivers) (8)

For LED descriptions, see [Appendix E, “LEDs”](#).

This section includes the following topics:

- [Ports for the Cisco Nexus 2232TM FEX, page 3-17](#)
- [Power Supplies for the Cisco Nexus 2232TM FEX, page 3-17](#)
- [Fan Tray for the Cisco Nexus 2232TM FEX, page 3-18](#)
- [Transceivers and Connectors Supported by the Cisco Nexus 2232TM FEX, page 3-19](#)

Ports for the Cisco Nexus 2232TM FEX

The downlink and uplink ports are numbered from top to bottom and then from left to right as shown in [Figure 3-23](#).

Figure 3-18 Port Numbering on the Cisco Nexus 2232TM FEX

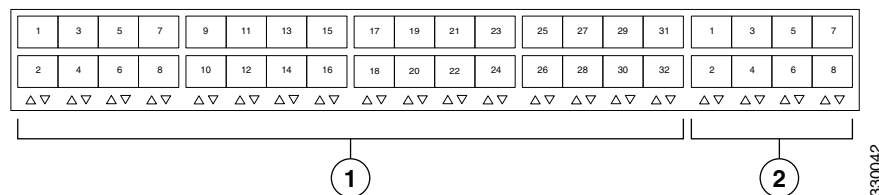

1	1- and 10-Gigabit Ethernet downlink ports, numbered 1 through 32	2	10-Gigabit Ethernet uplink ports, numbered 1 through 8
----------	--	----------	--

For information about the transceivers and connectors that you can use with these ports, see the [“Transceivers and Connectors Supported by the Cisco Nexus 2232TM FEX”](#) section on [page 3-19](#).

Power Supplies for the Cisco Nexus 2232TM FEX

The Cisco Nexus 2200 Platform FEX chassis have two slots for front-end AC or DC power supplies that have port-side-exhaust or port-side-intake airflow. These chassis are fully functional with one power supply, but you can install a second power supply for power redundancy. You can install any of the following power supplies in those two bays:

- AC power supply with port-side-exhaust airflow (N2200-PAC-400W)
- AC power supply with port-side-intake airflow (N2200-PAC-400W-B)
- DC power supply with port-side-exhaust airflow (N2200-PDC-400W)
- DC power supply with port-side-intake airflow (N2200-PDC-350W-B)



Caution

Make sure that all of the fan tray and power supply modules use the same airflow direction and have the same color designation on the front. Otherwise, the switch can over heat and shut down,

If you have only one power supply in a chassis, then you must install a blank filler plate (N2200-P-BLNK) in the open slot to maintain the designed airflow.

For more information on these power supplies, see the “Power Supplies for the Cisco Nexus 2248TP-E FEX” section on page 3-4 and the power supply specifications in the Appendix B, “Technical Specifications”.

Fan Tray for the Cisco Nexus 2232TM FEX

The Cisco Nexus 2232PP and 2232TM FEX use the same fan tray, which you can order with either port-side-exhaust airflow (N2K-C2232-FAN) or port-side-intake airflow (N2K-C2232-FAN-B). The fan tray includes a status LED that indicates whether the module is operational.



Caution

Make sure that all of the fan tray and power supply modules use the same airflow direction and have the same color designation on the front. Otherwise, the switch can over heat and shut down,

Figure 3-19 shows the fan tray with port-side-exhaust airflow (no black stripe across the front), and Figure 3-20 shows the fan tray with port-side-intake airflow (black stripe across the front).

Figure 3-19 Front-to-Back Airflow Fan Tray for the Cisco Nexus 2232PP and 2232TM FEXs

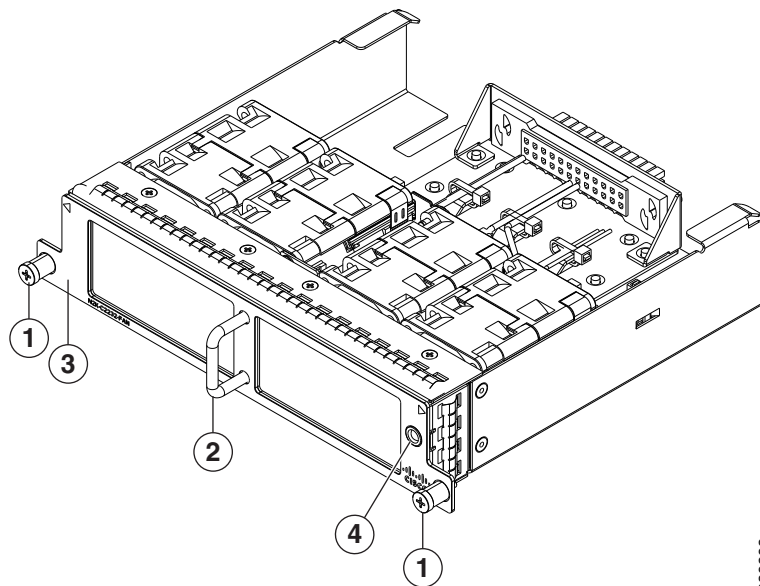

1	Captive screws (2)	3	Front-to-back airflow indicated by a lack of black stripe on the front.
2	Handle used for removing and installing the module	4	Status LED

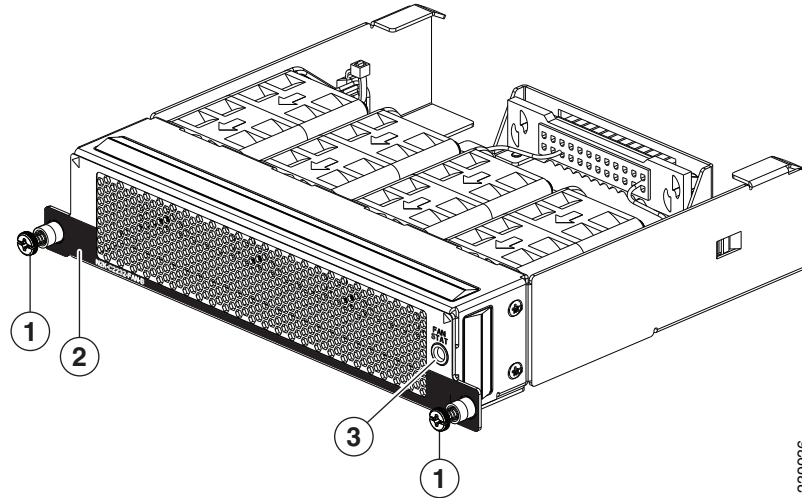
Figure 3-20 Back-to-Front Airflow Fan Tray for the Cisco Nexus 2232PP and 2232TM FEXs

1	Captive screws (2)	3	Back-to-front airflow indicated by a black stripe on the front.
2	Handle used for removing and installing the module	4	Status LED

For more information on this fan tray, see the fan tray specifications in [Appendix B, “Technical Specifications”](#). For LED descriptions, see [Appendix E, “LEDs”](#). To replace one of these fan trays, see [“Removing and Installing the Fan Tray”](#) section on page 4-21.

Transceivers and Connectors Supported by the Cisco Nexus 2232TM FEX

The Cisco Nexus 2232TM FEX supports SFP+ Ethernet optical and copper transceivers and optical FEX Transceivers (FETs) for up to eight fabric uplink connections to the Cisco Nexus 9396PX switch.

The Cisco Nexus 2232TM FEX also supports RJ-45 connectors for up to 32 downlink connections to hosts. [Table 3-2](#) lists the transceivers and connectors supported by this FEX for its uplink and downlink connections.

Table 3-6 Supported Transceivers and Connector for the Cisco Nexus 2232TM FEX Interfaces

Transceiver or Connector	Cable Type	Fabric Interface (Uplink)	Host Interface (Downlink)	Comments
FET-10G	Optical	X	–	10-Gbps FEX transceiver
SFP-10G-LR	Optical	X	–	10-Gbps long range transceiver (up to 6.2 miles [10 km])
SFP-10G-SR	Optical	X	–	10-Gbps Short range transceiver (up to 984 feet [300 m])
SFP-H10GB-CU1M	Copper	X	–	10-Gbps Twinax, passive transceiver (3.3 feet [1 meter])
SFP-H10GB-CU3M	Copper	X	–	10-Gbps Twinax, passive transceiver (9.8 feet [3 meters])
SFP-H10GB-CU5M	Copper	X	–	10-Gbps Twinax, passive transceiver (16.4 feet [5 meters])

Table 3-6 Supported Transceivers and Connector for the Cisco Nexus 2232TM FEX Interfaces

Transceiver or Connector	Cable Type	Fabric Interface (Uplink)	Host Interface (Downlink)	Comments
SFP-H10GB-ACU7M	Copper	X	–	10-Gbps Twinax, active transceiver (23.0 feet [7 meters])
SFP-H10GB-ACU10M	Copper	X	–	10-Gbps Twinax, active transceiver (32.8 feet [10 meters])
SFP-10G-AOC1M	Optical	X	–	10-Gbps active optical cable (3.3 feet [1 meter])
SFP-10G-AOC2M	Optical	X	–	10-Gbps active optical cable (6.6 feet [2 meters])
SFP-10G-AOC3M	Optical	X	–	10-Gbps active optical cable (9.8 feet [3 meters])
SFP-10G-AOC5M	Optical	X	–	10-Gbps active optical cable (16.4 feet [5 meters])
SFP-10G-AOC7M	Optical	X	–	10-Gbps active optical cable (23.0 feet [7 meters])
SFP-10G-AOC10M	Optical	X	–	10-Gbps active optical cable (32.8 feet [10 meters])
QSFP-4X10G-AOC1M	Optical	X	–	40- and 10-Gbps active optical breakout cable (3.3 feet [1 meter])
QSFP-4X10G-AOC2M	Optical	X	–	40- and 10-Gbps active optical breakout cable (6.6 feet [2 meters])
QSFP-4X10G-AOC3M	Optical	X	–	40- and 10-Gbps active optical breakout cable (9.8 feet [3 meters])
QSFP-4X10G-AOC5M	Optical	X	–	40- and 10-Gbps active optical breakout cable (16.4 feet [5 meters])
QSFP-4X10G-AOC7M	Optical	X	–	40- and 10-Gbps active optical breakout cable (23.0 feet [7 meters])
QSFP-4X10G-AOC10M	Optical	X	–	40- and 10-Gbps active optical breakout cable (32.8 feet [10 meters])
QSFP-4SFP10G-CU1M	Optical	X	–	40- and 10-Gbps copper breakout cable (3.3 feet [1 meter])
QSFP-4SFP10G-CU3M	Optical	X	–	40- and 10-Gbps copper breakout cable (9.8 feet [3 meters])
QSFP-4SFP10G-CU5M	Optical	X	–	40- and 10-Gbps copper breakout cable (16.4 feet [5 meters])
QSFP-4SFP10G-CU7M	Optical	X	–	40- and 10-Gbps copper breakout cable (23.0 feet [7 meters])
QSFP-4SFP10G-CU10M	Optical	X	–	40- and 10-Gbps copper breakout cable (32.8 feet [10 meters])
RJ-45	Copper	–	X	100/1000 Mbps Connector

For more information on the transceivers that you can use with this FEX, see the *Cisco Transceiver Modules Compatibility Information* at <http://www.cisco.com/c/en/us/support/interfaces-modules/transceiver-modules/products-device-support-tables-list.html>.

Figure 3-10 on page 3-9 shows the major features of the SFP+ optical transceiver used for uplink connections.

Figure 3-11 on page 3-10 shows the major features of the SFP+ copper transceiver and cable used for uplink connections.

Figure 3-12 on page 3-10 shows the major features of RJ-45 connectors, which are used for the downlink connections.

Cisco Nexus 2232PP FEX

The Cisco Nexus 2232PP FEX (N2K-C2248PP) is a stackable 1-RU FEX that has 32 1- and 10-Gigabit Ethernet host interfaces (downlink ports for SFP and SFP+ transceivers) and eight 10-Gigabit Ethernet and Fibre Channel over Ethernet (FCoE) fabric interfaces (uplink ports for SFP+ transceivers). This FEX requires a 19-inch (48.26 cm) rack for its installation. [Table 3-7](#) lists its physical characteristics.

Table 3-7 Physical Characteristics for the Cisco Nexus 2232PP FEX

Dimensions	
Width	17.3 inches (43.94 cm)
Depth	17.7 inches (44.96 cm)
Height	1.72 inches (4.37 cm)
<hr/>	
Weight ¹	18.3 lb (8.3 kg)

1. Measured with two power supplies and one fan module installed

You can order the Cisco Nexus 2232PP with front-to-back (port-side exhaust) or back-to-front (port-side intake) airflow and with AC or DC power supplies. If you are going to install the port side in a hot aisle, then order port-side-exhaust airflow for the fan trays and power supplies. If you are going to install the port side in the cold aisle, order port-side-intake airflow for the fan trays and power supplies.



Caution

Make sure that all of the fan tray and power supply modules use the same airflow direction and have the same color designation on the front. Otherwise, the switch can over heat and shut down,

The front of the Cisco Nexus 2232PP FEX chassis has one or two power supplies, a fan tray, and two LEDs as shown in [Figure 3-21](#). This FEX model requires one power supply, but if you want power redundancy, you must install a second power supply.

Figure 3-21 Front View of the Cisco Nexus 2232PP Chassis

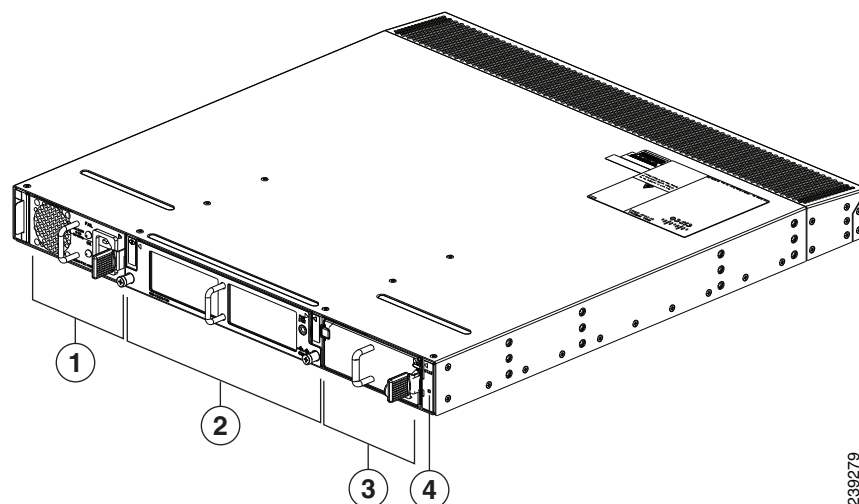

1	Power supply	3	Power supply (blank shown)
2	Fan tray	4	Status (top) and ID (bottom) LEDs

The rear of the Cisco Nexus 2232PP FEX has 32 1- and 10-Gigabit Ethernet downlink SFP or SFP+ ports, eight 10-Gigabit Ethernet uplink SFP+ or FET ports, an HDMI port, and two LEDs, as shown in [Figure 3-22](#).

Figure 3-22 Rear View of the Cisco Nexus 2232PP Chassis

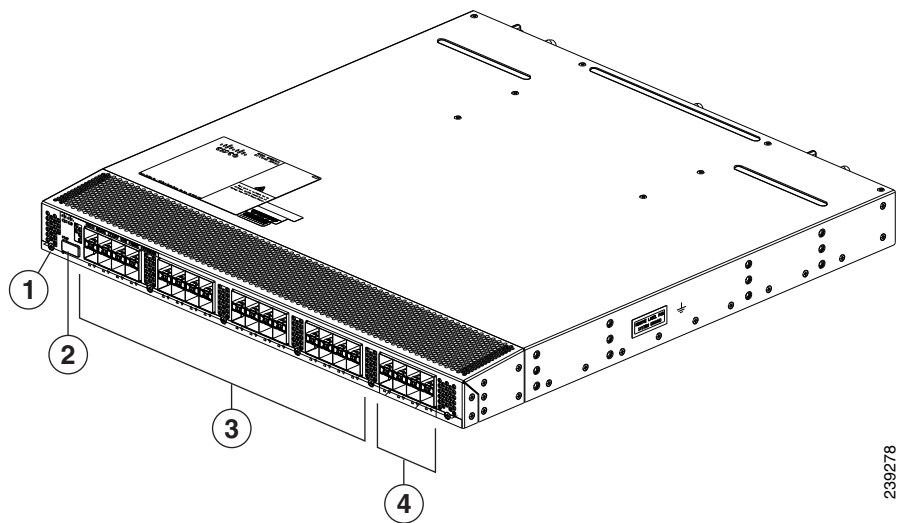

1	Status (top) and ID (bottom) LEDs	3	1- and 10-Gigabit Ethernet host ports (copper/optical downlink ports for SFP or SFP+ transceivers) (48)
2	HDMI port	4	10-Gigabit Ethernet fabric ports (copper/optical uplink ports for SFP+ or FET transceivers) (4)

For LED descriptions, see [Appendix E, “LEDs.”](#)

This section includes the following topics:

- [Ports for the Cisco Nexus 2232PP FEX, page 3-22](#)
- [Power Supplies for the Cisco Nexus 2232PP FEX, page 3-23](#)
- [Fan Tray for the Cisco Nexus 2232PP FEX, page 3-23](#)
- [Transceivers Supported by the Cisco Nexus 2232PP FEX, page 3-24](#)

Ports for the Cisco Nexus 2232PP FEX

The downlink and uplink ports are numbered from top to bottom and then from left to right as shown in [Figure 3-23](#).

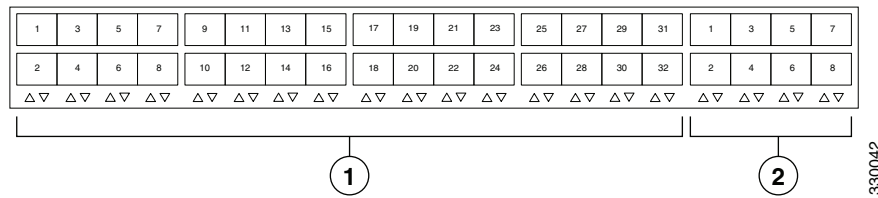
Figure 3-23 Port Numbering on the Cisco Nexus 2232PP FEX

1	1- and 10-Gigabit Ethernet downlink ports, numbered 1 through 32	2	10-Gigabit Ethernet uplink ports, numbered 1 through 8
----------	--	----------	--

For information about the transceivers and connectors that you can use with these ports, see the [“Transceivers Supported by the Cisco Nexus 2232PP FEX”](#) section on page 3-24.

Power Supplies for the Cisco Nexus 2232PP FEX

The Cisco Nexus 2200 Platform FEX chassis have two slots for front-end AC or DC power supplies that have port-side-exhaust or port-side-intake airflow. These chassis are fully functional with one power supply, but you can install a second power supply for power redundancy. You can install any of the following power supplies in those two bays:

- AC power supply with port-side-exhaust airflow (N2200-PAC-400W)
- AC power supply with port-side-intake airflow (N2200-PAC-400W-B)
- DC power supply with port-side-exhaust airflow (N2200-PDC-400W)
- DC power supply with port-side-intake airflow (N2200-PDC-350W-B)



Caution

Make sure that all of the fan tray and power supply modules use the same airflow direction and have the same color designation on the front. Otherwise, the switch can over heat and shut down,

For information on these power supplies, see the [“Power Supplies for the Cisco Nexus 2248TP FEX”](#) section on page 3-13 and the power supply specifications in the [Appendix B, “Technical Specifications”](#).

Fan Tray for the Cisco Nexus 2232PP FEX

The Cisco Nexus 2232PP and 2232TM FEX use the same fan tray, which you can order with either port-side-exhaust airflow (N2K-C2232-FAN) or port-side-intake airflow (N2K-C2232-FAN-B).



Caution

Make sure that all of the fan tray and power supply modules use the same airflow direction and have the same color designation on the front. Otherwise, the switch can over heat and shut down,

For more information on this fan tray, see the [“Fan Tray for the Cisco Nexus 2232TM FEX”](#) section on page 3-18 and the fan tray specifications in [Appendix B, “Technical Specifications”](#). For LED descriptions, see [Appendix E, “LEDs”](#).

Transceivers Supported by the Cisco Nexus 2232PP FEX

The Cisco Nexus 2232PP FEX supports copper or optical SFP and SFP+ transceivers for up to 32 host downlink connections and optical FEX Transceivers (FETs) and SFP+ transceivers for up to eight fabric uplink connections, as specified in the following table.

Table 3-8 Supported Transceivers and Connector for the Cisco Nexus 2232PP FEX Interfaces

Transceiver or Connector	Cable Type	Fabric Interface (Uplink)	Host Interface (Downlink)	Comments
FET-10G	Optical	X	–	10-Gbps FEX transceiver
GLC-LH-SM	Optical		X	1-Gbps
GLC-SX-MM	Optical		X	1-Gbps
GLC-T	Copper		X	1-Gbps
SFP-GE-L	Optical		X	1-Gbps
SFP-GE-S	Optical		X	1-Gbps
SFP-GE-T	Copper		X	1-Gbps
SFP-10G-LR	Optical	X	X	10-Gbps long range transceiver (up to 6.2 miles [10 km])
SFP-10G-SR	Optical	X	X	10-Gbps Short range transceiver (up to 984 feet [300 m])
SFP -H10GB-CU1M	Copper	X	X	10-Gbps Twinax, passive transceiver (3.3 feet [1 meter])
SFP -H10GB-CU3M	Copper	X	X	10-Gbps Twinax, passive transceiver (9.8 feet [3 meters])
SFP -H10GB-CU5M	Copper	X	X	10-Gbps Twinax, passive transceiver (16.4 feet [5 meters])
SFP -H10GB-ACU7M	Copper	X	X	10-Gbps Twinax, active transceiver (23.0 feet [7 meters])
SFP -H10GB-ACU10M	Copper	X	X	10-Gbps Twinax, active transceiver (32.8 feet [10 meters])
SFP-10G-AOC1M	Optical	X	X	10-Gbps active optical cable (3.3 feet [1 meter])
SFP-10G-AOC2M	Optical	X	X	10-Gbps active optical cable (6.6 feet [2 meters])
SFP-10G-AOC3M	Optical	X	X	10-Gbps active optical cable (9.8 feet [3 meters])
SFP-10G-AOC5M	Optical	X	X	10-Gbps active optical cable (16.4 feet [5 meters])
SFP-10G-AOC7M	Optical	X	X	10-Gbps active optical cable (23.0 feet [7 meters])
SFP-10G-AOC10M	Optical	X	X	10-Gbps active optical cable (32.8 feet [10 meters])
QSFP-4X10G-AOC1M	Optical	X	–	40- and 10-Gbps active optical breakout cable (3.3 feet [1 meter])
QSFP-4X10G-AOC2M	Optical	X	–	40- and 10-Gbps active optical breakout cable (6.6 feet [2 meters])
QSFP-4X10G-AOC3M	Optical	X	–	40- and 10-Gbps active optical breakout cable (9.8 feet [3 meters])
QSFP-4X10G-AOC5M	Optical	X	–	40- and 10-Gbps active optical breakout cable (16.4 feet [5 meters])
QSFP-4X10G-AOC7M	Optical	X	–	40- and 10-Gbps active optical breakout cable (23.0 feet [7 meters])

Table 3-8 Supported Transceivers and Connector for the Cisco Nexus 2224TP FEX Interfaces

Transceiver or Connector	Cable Type	Fabric Interface (Uplink)	Host Interface (Downlink)	Comments
QSFP-4X10G-AOC10M	Optical	X	–	40- and 10-Gbps active optical breakout cable (32.8 feet [10 meters])
QSFP-4SFP10G-CU1M	Optical	X	–	40- and 10-Gbps copper breakout cable (3.3 feet [1 meter])
QSFP-4SFP10G-CU3M	Optical	X	–	40- and 10-Gbps copper breakout cable (9.8 feet [3 meters])
QSFP-4SFP10G-CU5M	Optical	X	–	40- and 10-Gbps copper breakout cable (16.4 feet [5 meters])
QSFP-4SFP10G-CU7M	Optical	X	–	40- and 10-Gbps copper breakout cable (23.0 feet [7 meters])
QSFP-4SFP10G-CU10M	Optical	X	–	40- and 10-Gbps copper breakout cable (32.8 feet [10 meters])
RJ-45	Copper	–	X	100/1000 Mbps Connector

For more information on the transceivers that you can use with this FEX, see the *Cisco Transceiver Modules Compatibility Information* at <http://www.cisco.com/c/en/us/support/interfaces-modules/transceiver-modules/products-device-support-tables-list.html>.

Figure 3-10 on page 3-9 shows the major features of the SFP+ optical transceiver used for uplink connections.

Figure 3-11 on page 3-10 shows the major features of the SFP+ copper transceiver and cable used for uplink connections.

Figure 3-12 on page 3-10 shows the major features of RJ-45 connectors, which are used for the downlink connections.

Cisco Nexus 2224TP FEX

The Cisco Nexus 2224TP FEX is a stackable, 1-RU FEX that has 24 100/1000 Ethernet host interfaces (100/1000BASE-T downlink ports for RJ-45 connectors) and two 10-Gigabit Ethernet fabric interfaces (copper/optical uplink ports for SFP+ transceivers). It requires a 19-inch (48.26 cm) rack for its installation. Table 3-9 lists its physical characteristics.

Table 3-9 Physical Characteristics for the Cisco Nexus 2224TP FEX

Dimensions	
Width	17.3 inches (43.94 cm)
Depth	17.7 inches (44.96 cm)
Height	1.72 inches (4.37 cm)
Weight ¹	16.6 lb (7.53 kg)

1. Measured with two power supplies and one fan module installed.

You can order the Cisco Nexus 2224TP FEX with front-to-back (port-side exhaust) or port-side-intake (port-side intake) airflow and with AC or DC power supplies. If you are going to install the port side in a hot aisle, then order port-side-exhaust airflow for the fan trays and power supplies. If you are going to install the port side in the cold aisle, order port-side-intake airflow for the fan trays and power supplies.

The front of the Cisco Nexus 2224TP FEX chassis has one or two power supplies, a fan tray, and two LEDs as shown in [Figure 3-24](#). This FEX model requires one power supply, but if you want power redundancy, you must install a second power supply.

**Caution**

Make sure that all of the fan tray and power supply modules use the same airflow direction and have the same color designation on the front. Otherwise, the switch can over heat and shut down,

Figure 3-24 Front View of the Cisco Nexus 2224TP Chassis

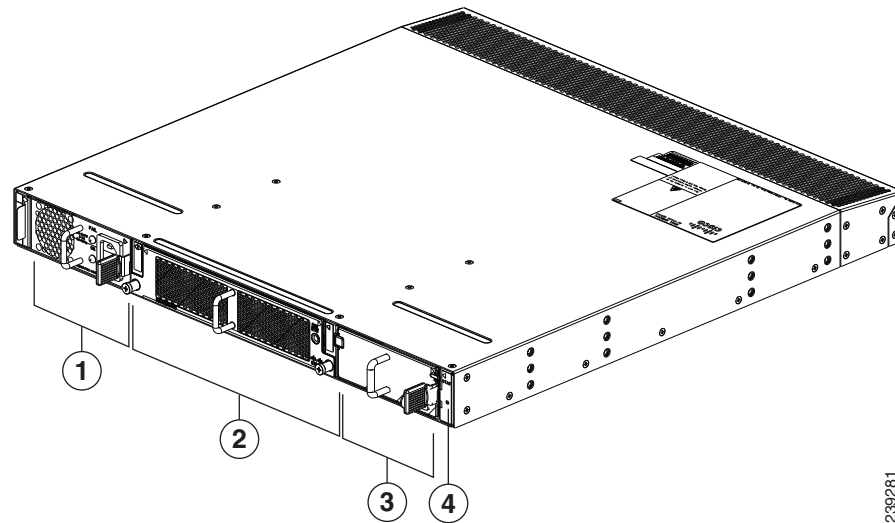

239281

1	Power supply	3	Power supply (blank shown)
2	Fan tray	4	Status (top) and ID (bottom) LEDs

The rear of the Cisco Nexus 2224TP FEX has 24 100/1000BASE-T Ethernet downlink ports, two 10-Gigabit Ethernet uplink ports, an HDMI port, and LEDs, as shown in [Figure 3-25](#).

Figure 3-25 Rear View of the Cisco Nexus 2224TP Chassis

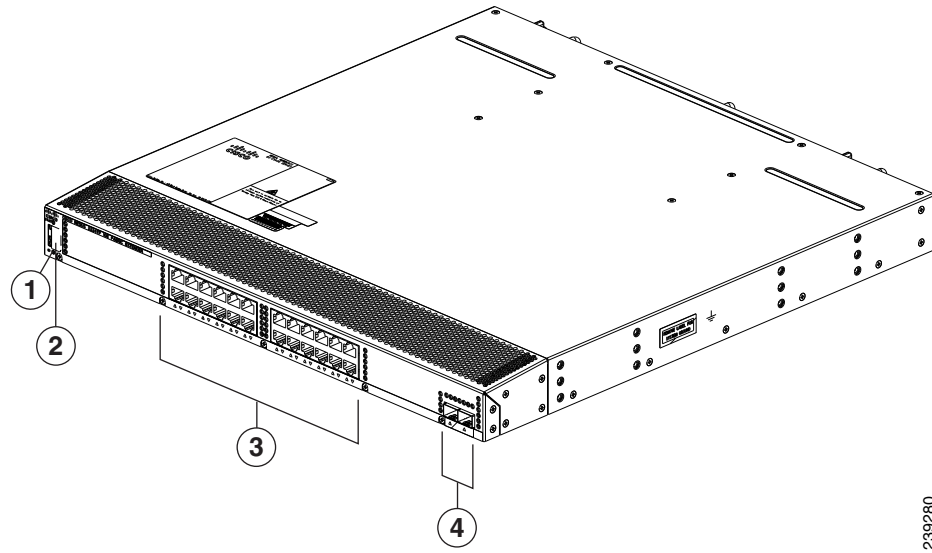

1	Status (top) and ID (bottom) LEDs	3	100/1000BASE-T Ethernet downlink ports (24)
2	HDMI port	4	10-Gigabit Ethernet uplink ports (2)

For LED descriptions, see [Appendix E, “LEDs.”](#)

This section includes the following topics:

- [Ports for the Cisco Nexus 2224TP FEX, page 3-27](#)
- [Power Supplies for the Cisco Nexus 2224TP FEX, page 3-28](#)
- [Fan Tray for the Cisco Nexus 2224TP FEX, page 3-28](#)
- [Transceivers and Connectors Supported by the Cisco Nexus 2224TP FEX, page 3-28](#)

Ports for the Cisco Nexus 2224TP FEX

The downlink and uplink ports are numbered from top to bottom and then from left to right as shown in [Figure 3-26](#).

Figure 3-26 Port Numbering on the Cisco Nexus 2224TP FEX

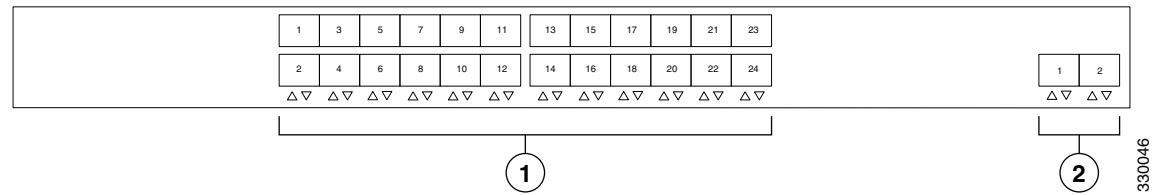

1	1- and 10-Gigabit Ethernet downlink ports, numbered 1 through 24	2	10-Gigabit Ethernet uplink ports, numbered 1 through 2
----------	--	----------	--

For information about the transceivers and connectors that you can use with these ports, see the [“Transceivers and Connectors Supported by the Cisco Nexus 2224TP FEX”](#) section on page 3-28.

Power Supplies for the Cisco Nexus 2224TP FEX

The Cisco Nexus 2200 Platform FEX chassis have two slots for front-end AC or DC power supplies that have port-side-exhaust or port-side-intake airflow. These chassis are fully functional with one power supply, but you can install a second power supply for power redundancy. You can install any of the following power supplies in those two bays:

- AC power supply with port-side-exhaust airflow (N2200-PAC-400W)
- AC power supply with port-side-intake airflow (N2200-PAC-400W-B)
- DC power supply with port-side-exhaust airflow (N2200-PDC-400W)
- DC power supply with port-side-intake airflow (N2200-PDC-350W-B)



Caution

Make sure that all of the fan tray and power supply modules use the same airflow direction and have the same color designation on the front. Otherwise, the switch can over heat and shut down,

For information on these power supplies, see the [“Power Supplies for the Cisco Nexus 2248TP FEX”](#) section on page 3-13 and the power supply specifications in the [Appendix B, “Technical Specifications”](#).

Fan Tray for the Cisco Nexus 2224TP FEX

The Cisco Nexus 2224TP, 2248TP, and 2248TP-E FEXs use the same fan tray that you can order with either port-side-exhaust airflow (N2K-C2248-FAN) or port-side-intake airflow (N2K-C2248-FAN-B).

For information on this fan tray, see the [“Fan Tray for the Cisco Nexus 2248TP FEX”](#) section on page 3-13 and the fan tray specifications in [Appendix B, “Technical Specifications”](#). For LED descriptions, see [Appendix E, “LEDs”](#). To replace one of these fan trays, see [“Removing and Installing the Fan Tray”](#) section on page 4-21.

Transceivers and Connectors Supported by the Cisco Nexus 2224TP FEX

The Cisco Nexus 2224TP FEX supports SFP+ Ethernet optical and copper transceivers and optical FEX Transceivers (FETs) for up to two fabric uplink connections to Cisco Nexus 9396PX switches, and it supports RJ-45 connectors for up to 24 downlink connections to hosts. [Table 3-2](#) lists the transceivers supported by this FEX for its uplink and downlink connections.

Table 3-10 Supported Transceivers and Connector for the Cisco Nexus 2224TP FEX Interfaces

Transceiver or Connector	Cable Type	Fabric Interface (Uplink)	Host Interface (Downlink)	Comments
FET-10G	Optical	X	–	10-Gbps FEX transceiver
SFP-10G-LR	Optical	X	–	10-Gbps long range transceiver (up to 6.2 miles [10 km])
SFP-10G-SR	Optical	X	–	10-Gbps Short range transceiver (up to 984 feet [300 m])

Table 3-10 Supported Transceivers and Connector for the Cisco Nexus 2224TP FEX Interfaces

Transceiver or Connector	Cable Type	Fabric Interface (Uplink)	Host Interface (Downlink)	Comments
SFP -H10GB-CU1M	Copper	X	–	10-Gbps Twinax, passive transceiver (3.3 feet [1 meter])
SFP -H10GB-CU3M	Copper	X	–	10-Gbps Twinax, passive transceiver (9.8 feet [3 meters])
SFP -H10GB-CU5M	Copper	X	–	10-Gbps Twinax, passive transceiver (16.4 feet [5 meters])
SFP -H10GB-ACU7M	Copper	X	–	10-Gbps Twinax, active transceiver (23.0 feet [7 meters])
SFP -H10GB-ACU10M	Copper	X	–	10-Gbps Twinax, active transceiver (32.8 feet [10 meters])
SFP-10G-AOC1M	Optical	X	–	10-Gbps active optical cable (3.3 feet [1 meter])
SFP-10G-AOC2M	Optical	X	–	10-Gbps active optical cable (6.6 feet [2 meters])
SFP-10G-AOC3M	Optical	X	–	10-Gbps active optical cable (9.8 feet [3 meters])
SFP-10G-AOC5M	Optical	X	–	10-Gbps active optical cable (16.4 feet [5 meters])
SFP-10G-AOC7M	Optical	X	–	10-Gbps active optical cable (23.0 feet [7 meters])
SFP-10G-AOC10M	Optical	X	–	10-Gbps active optical cable (32.8 feet [10 meters])
QSFP-4X10G-AOC1M	Optical	X	–	40- and 10-Gbps active optical breakout cable (3.3 feet [1 meter])
QSFP-4X10G-AOC2M	Optical	X	–	40- and 10-Gbps active optical breakout cable (6.6 feet [2 meters])
QSFP-4X10G-AOC3M	Optical	X	–	40- and 10-Gbps active optical breakout cable (9.8 feet [3 meters])
QSFP-4X10G-AOC5M	Optical	X	–	40- and 10-Gbps active optical breakout cable (16.4 feet [5 meters])
QSFP-4X10G-AOC7M	Optical	X	–	40- and 10-Gbps active optical breakout cable (23.0 feet [7 meters])
QSFP-4X10G-AOC10M	Optical	X	–	40- and 10-Gbps active optical breakout cable (32.8 feet [10 meters])
QSFP-4SFP10G-CU1M	Optical	X	–	40- and 10-Gbps copper breakout cable (3.3 feet [1 meter])
QSFP-4SFP10G-CU3M	Optical	X	–	40- and 10-Gbps copper breakout cable (9.8 feet [3 meters])
QSFP-4SFP10G-CU5M	Optical	X	–	40- and 10-Gbps copper breakout cable (16.4 feet [5 meters])
QSFP-4SFP10G-CU7M	Optical	X	–	40- and 10-Gbps copper breakout cable (23.0 feet [7 meters])
QSFP-4SFP10G-CU10M	Optical	X	–	40- and 10-Gbps copper breakout cable (32.8 feet [10 meters])
RJ-45	Copper	–	X	100/1000 Mbps Connector

For more information on the transceivers that you can use with this FEX, see the *Cisco Transceiver Modules Compatibility Information* at <http://www.cisco.com/c/en/us/support/interfaces-modules/transceiver-modules/products-device-support-tables-list.html>.

[Figure 3-10 on page 3-9](#) shows the SFP+ optical transceiver used for uplink connections.

[Figure 3-11 on page 3-10](#) identifies the major features of the SFP+ copper transceiver and cable used for uplink connections.

[Figure 3-12 on page 3-10](#) identifies the major features of RJ-45 connectors, which are used for the downlink connections.



Installing a Cisco Nexus Fabric Extender

This chapter describes how to install the Cisco Nexus Fabric Extenders (FEXs) and includes the following sections:

- [Preparing for Installation, page 4-2](#)
- [Installing the Cisco Nexus Fabric Extender Chassis in a Cabinet or Rack, page 4-6](#)
- [Grounding the System, page 4-7](#)
- [Grounding the Chassis, page 4-14](#)
- [Starting the Cisco Nexus Fabric Extender, page 4-14](#)
- [Removing and Installing Components, page 4-16](#)
- [Repacking the Cisco Nexus Fabric Extender for Return Shipment, page 4-23](#)



Note

Before you install, operate, or service the system, read the *Regulatory Compliance and Safety Information* for important safety information.



Warning

IMPORTANT SAFETY INSTRUCTIONS

This warning symbol means danger. You are in a situation that could cause bodily injury. Before you work on any equipment, be aware of the hazards involved with electrical circuitry and be familiar with standard practices for preventing accidents. Use the statement number provided at the end of each warning to locate its translation in the translated safety warnings that accompanied this device.
Statement 1071



Warning

This unit is intended for installation in restricted access areas. A restricted access area can be accessed only through the use of a special tool, lock and key, or other means of security.

Statement 1017



Warning

Only trained and qualified personnel must be allowed to install, replace, or service this equipment.

Statement 1030

Preparing for Installation

This section includes the following topics:

- [Installation Options, page 4-2](#)
- [Airflow Considerations, page 4-2](#)
- [Chassis Weight, page 4-3](#)
- [Installation Guidelines, page 4-3](#)
- [Required Tools and Equipment, page 4-4](#)
- [Unpacking and Inspecting the Cisco Nexus Fabric Extender, page 4-5](#)

Installation Options

The Cisco Nexus FEX can be installed using the following methods:

- In an open EIA rack, using the following items:
 - The rack-mount kit shipped with the device
 - The EIA Shelf Bracket Kit (an optional kit, purchased separately)
- In a perforated or solid-walled EIA cabinet, using one of the following:
 - The rack-mount kit shipped with the device
 - The EIA Shelf Bracket Kit (an optional kit, purchased separately)

For instructions on installing the device using the rack-mount kit shipped with the device, see the [“Installing the Cisco Nexus Fabric Extender Chassis in a Cabinet or Rack”](#) section on page 4-6.

**Note**

The optional EIA Shelf Bracket Kit is not provided with the device. To order the kit, contact your device provider.

Airflow Considerations

Airflow through the Cisco Nexus FEX is from the port side exhaust to the back or the back to the port side exhaust. To ensure proper airflow, follow these guidelines:

- Position the chassis so that its air intake side (port side exhaust side for port side exhaust airflow or back side for port side intake airflow) is in a cold aisle. Otherwise, an overtemperature condition can occur and the system can shut down.
- Avoid having the air intake where other systems exhaust air.
- Due to the shallow depth of the Cisco Nexus FEX, it is also possible for air to recirculate across the top and bottom of the chassis in a partially populated rack.
- Make sure that the fan tray and power supply modules all use the same direction of airflow. All of the modules should have no black stripe (port side exhaust airflow) or all of the modules should have a black stripe (port side intake airflow).

**Note**

If the switch is powered up with modules that have different airflow directions, you need to shut down the switch before replacing the modules with the wrong airflow direction.

- Maintain ambient airflow throughout the data center to ensure normal operation.
- Consider the heat dissipation of all equipment when determining air-conditioning requirements. When evaluating airflow requirements, take into consideration that hot air generated by equipment at the bottom of the rack can be drawn in the intake ports of the equipment above.
- If you mount a chimney type of rack, avoid mounting it in a way that is contrary to the direction of flow in the chimney, where the chimney overpowers the system fans.

Chassis Weight

When lifting the system, follow these guidelines:

- Disconnect all power and external cables before lifting the system.
- Have two people lift the system. The Cisco Nexus FEXs can weigh up to 18.5 pounds (8.4 kg).
- Ensure that your footing is solid and the weight of the system is evenly distributed between your feet.
- Lift the system slowly, keeping your back straight. Lift with your legs, not with your back. Bend at the knees, not at the waist.

Installation Guidelines

When installing the Cisco Nexus FEX, follow these guidelines:

- Plan your site configuration and prepare the site before installing the chassis. Appendix G, “Site Preparation and Maintenance Records,” lists the recommended site planning tasks.
- Record the information listed in Appendix G, “Site Preparation and Maintenance Records,” as you install and configure the device.
- Ensure that there is adequate space around the device to allow for servicing the device and for adequate airflow ([Appendix B, “Technical Specifications,”](#) lists airflow requirements).
- Ensure that the air-conditioning meets the heat dissipation requirements listed in [Appendix B, “Technical Specifications,”](#)
- Ensure that the chassis air intake will be located in a cold aisle and away from the exhaust of other systems.
- Ensure that all of the fan tray and power supply modules have the same direction of airflow as follows (the switch supports only one airflow direction for all modules):
 - Port-side intake airflow modules have black stripes.
 - Port-side exhaust airflow modules have no colored stripes.

**Note**

If the switch is powered up with modules that have different airflow directions, you need to shut down the switch before replacing the modules with the wrong airflow direction.

- Ensure that the cabinet or rack meets the requirements listed in [Appendix A, “Cabinet and Rack Installation.”](#)



Note Jumper power cords are available for use in a cabinet. See the [“Jumper Power Cord” section on page C-8.](#)

- Ensure that the chassis is adequately grounded. If the device is not mounted in a grounded rack, we recommend connecting both the system ground on the chassis and the power supply ground to an earth ground.
- Ensure that the site power meets the power requirements listed in [Appendix B, “Technical Specifications,”](#) If available, you can use an uninterruptible power supply (UPS) to protect against power failures.



Caution Avoid UPS types that use ferroresonant technology. These UPS types can become unstable with systems such as the Cisco Nexus FEX, which can have substantial current draw fluctuations because of fluctuating data traffic patterns.

- Ensure that circuits are sized according to local and national codes. For North America, the power supply requires a 15-A or 20-A circuit.



Caution To prevent loss of input power, ensure the total maximum loads on the circuits supplying power to the device are within the current ratings for the wiring and breakers.

- Use the following screw torques when installing the device:
 - Captive screws: 4 in-lb
 - M3 screws: 4 in-lb
 - M4 screws: 12 in-lb
 - 10-32 screws: 20 in-lb
 - 12-24 screws: 30 in-lb

Required Tools and Equipment

Before beginning the installation, ensure that the following items are ready:

- Number 1 and number 2 Phillips screwdrivers with torque capability
- 3/16-inches flat-blade screwdriver
- Tape measure and level
- ESD wrist strap or other grounding device
- Antistatic mat or antistatic foam

The following additional items (not found in the accessory kit) are required to ground the chassis:

- Grounding cable (6 AWG recommended), sized according to local and national installation requirements; the required length depends on the proximity of the Cisco Nexus FEX to proper grounding facilities
- Crimping tool large enough to accommodate girth of lug

- Wire-stripping tool

Unpacking and Inspecting the Cisco Nexus Fabric Extender

**Caution**

When handling device components, wear an ESD wrist strap and handle modules by the carrier edges only. An ESD socket is provided on the chassis. For the ESD socket to be effective, the chassis must be grounded through the power cable, the chassis ground, or the metal-to-metal contact with a grounded rack.

**Tip**

Keep the shipping container in case the chassis requires shipping in the future.

**Note**

The device is thoroughly inspected before shipment. If any damage occurred during transportation or any items are missing, contact your customer service representative immediately.

To inspect the shipment, follow these steps:

-
- Step 1** Compare the shipment to the equipment list provided by your customer service representative and verify that you have received all items, including the following:
- Print documentation
 - Grounding lug kit
 - Rack-mount kit
 - ESD wrist strap
 - Cables with connectors
 - Any optional items ordered
- Step 2** Check for damage and report any discrepancies or damage to your customer service representative. Have the following information ready:
- Invoice number of shipper (see packing slip)
 - Model and serial number of the damaged unit
 - Description of damage
 - Effect of damage on the installation
- Step 3** Make sure that the fan tray and power supplies all use the same direction of airflow.
- Port-side exhaust airflow modules do not have a black stripe across the front of the module.
 - Port-side intake airflow modules have a black stripe across the front of the module.
-

Installing the Cisco Nexus Fabric Extender Chassis in a Cabinet or Rack

This section describes how to use the rack-mount kit provided with the device to install the Cisco Nexus Fabric Extender into a cabinet or rack that meets the requirements described in [Appendix A, “Cabinet and Rack Installation.”](#)

Caution

If the rack is on wheels, ensure that the brakes are engaged or that the rack is otherwise stabilized.

[Table 4-1](#) lists the items contained in the rack-mount kit provided with the device.

Table 4-1 Cisco Nexus 2000 Series FEX Rack-Mount Kit

Quantity	Part Description
2	Rack-mount brackets
12	M4x0.7 x 8-mm Phillips countersunk screws
2	Rack-mount guides
10	10-32 rack nuts
10	10-32 x 3/4-inch Phillips pan head screws
2	Slider rails

[Table 4-1](#) lists the items contained in the rack-mount kit provided with the device.

Table 4-2 Cisco Nexus 2300 Series FEX Rack-Mount Kit

Quantity	Part Description
2	Rack-mount brackets
2	M4 8-mm Phillips pan head screws
2	Rack-mount guides
10	M4 x 0.7 x 7 mm rack nuts
10	10-32 x 3/4-inch Phillips pan head screws
2	Slider rails

To install the device in a cabinet or rack using the rack-mount kit provided with the device, follow these steps:

-
- Step 1** Install the front rack-mount brackets as follows:
- Position a front rack-mount bracket against the chassis and align the screw holes. Attach the front rack-mount bracket to the chassis with six of the M4 screws.
 - Repeat with the other front rack-mount bracket on the other side of the device.
- Step 2** Install the rack-mount guides on the device as follows:
- Position one of the rack-mount brackets against the side of the device and align the screw holes. Attach the bracket to the device with two of the flat-head M4 screws.
 - Repeat with the other rack-mount bracket on the other side of the device.
- Step 3** Attach the slider rails to the rack. Use two 12-24 screws or two 10-32 screws, depending on the rack rail thread type. For racks with square holes, insert the 12-24 cage nuts in position behind the mounting holes in the slider rails.
- Repeat with the other slider rail on the other side of the rack.
 - Use the tape measure and level to verify that the rails are horizontal and at the same height.
- Step 4** Insert the device into the rack as follows:
- Using both hands, position the device with the back of the device between the port side exhaust posts of the rack.
 - Align the two rack-mount guides on either side of the device with the slider rails installed in the rack. Slide the rack-mount glides onto the slider rails, and then gently slide the device all the way into the rack. If the device does not slide easily, try realigning the rack-mount glides on the slider rails.
- Step 5** Stabilize the device in the rack by attaching the front rack-mount brackets to the front rack-mounting rails as follows:
- Insert two screws (12-24 or 10-32, depending on the rack type) through the cage nuts and the holes in one of the front rack-mount brackets and into the threaded holes in the rack-mounting rail.
 - Repeat for the front rack-mount bracket on the other side of the device.
-

Grounding the System

This section describes the need for system grounding and explains how to prevent damage from electrostatic discharge.

This section includes the following topics:

- [Proper Grounding Guidelines, page 4-8](#)
- [Preventing Electrostatic Discharge Damage, page 4-9](#)
- [Establishing the System Ground, page 4-13](#)
- [Required Tools and Equipment, page 4-13](#)

Proper Grounding Guidelines

Grounding is one of the most important parts of equipment installation. Proper grounding practices ensure that the buildings and the installed equipment within them have low-impedance connections and low-voltage differentials between chassis. When you properly ground systems during installation, you reduce or prevent shock hazards, equipment damage due to transients, and data corruption. [Table 4-3](#) lists some general grounding practice guidelines.

Table 4-3 Proper Grounding Guidelines

Environment	Electromagnetic Noise Severity Level	Grounding Recommendations
Commercial building is subjected to direct lightning strikes. For example, some places in the United States, such as Florida, are subject to more lightning strikes than other areas.	High	All lightning protection devices must be installed in strict accordance with manufacturer recommendations. Conductors carrying lightning current should be spaced away from power and data lines in accordance with applicable recommendations and codes. Best grounding recommendations must be closely followed.
Commercial building is located in an area where lightning storms frequently occur but is not subject to direct lightning strikes.	High	Grounding recommendations must be closely followed.
Commercial building contains a mix of information technology equipment and industrial equipment, such as welding.	Medium to high	Grounding recommendations must be closely followed.
Existing commercial building is not subject to natural environmental noise or man-made industrial noise. This building contains a standard office environment. This installation has a history of malfunction due to electromagnetic noise.	Medium	Determine source and cause of noise if possible, and mitigate as closely as possible at the noise source or reduce coupling from the noise source to the affected equipment. Grounding recommendations must be closely followed.

Table 4-3 Proper Grounding Guidelines

Environment	Electromagnetic Noise Severity Level	Grounding Recommendations
New commercial building is not subject to natural environmental noise or man-made industrial noise. This building contains a standard office environment.	Low	Electromagnetic noise problems are not anticipated, but installing a grounding system in a new building is often the least expensive route and the best way to plan for the future. Grounding recommendations should be followed as closely as possible.
Existing commercial building is not subject to natural environmental noise or man-made industrial noise. This building contains a standard office environment.	Low	Electromagnetic noise problems are not anticipated, but installing a grounding system is always recommended. Grounding recommendations should be followed as much as possible.

**Note**

In all situations, grounding practices must comply with local National Electric Code (NEC) requirements or local laws and regulations.

**Note**

Always ensure that all of the devices are completely installed and that the captive installation screws are fully tightened. In addition, ensure that all I/O cables and power cords are properly seated. These practices are normal installation practices and must be followed in all installations.

Preventing Electrostatic Discharge Damage

Electrostatic discharge (ESD) damage, which can occur when modules or other Field Replaceable Units (FRUs) are improperly handled, results in intermittent or complete failures. Devices consist of printed circuit boards that are fixed in metal carriers. Electromagnetic interference (EMI) shielding and connectors are integral components of the carrier. Although the metal carrier helps to protect the board from ESD, always use an ESD grounding strap when handling modules.

For preventing ESD damage, follow these guidelines:

- Always use an ESD wrist strap and ensure that it makes maximum contact with bare skin.
- ESD grounding straps are available with banana plugs, metal spring clips, or alligator clips. All Cisco Nexus 2000 Series FEX chassis are equipped with a banana plug connector (identified by the ground symbol next to the connector) somewhere on the port side exhaust panel. We recommend that you use a personal ESD grounding strap equipped with a banana plug.
- If you choose to use the disposable ESD wrist strap supplied with most FRUs or an ESD wrist strap equipped with an alligator clip, you must attach the system ground lug to the chassis in order to provide a proper grounding point for the ESD wrist strap.

**Note**

This system ground is also referred to as the network equipment building system (NEBS) ground.

- If your chassis does not have the system ground attached, you must install the system ground lug. See the “[Establishing the System Ground](#)” section on page 4-13 for installation instructions and location of the chassis system ground pads.

**Note**

You do not need to attach a supplemental system ground wire to the system ground lug; the lug provides a direct path to the bare metal of the chassis.

After you install the system ground lug, follow these steps to correctly attach the ESD wrist strap:

-
- Step 1** Attach the ESD wrist strap to your bare skin as follows:
- If you are using the ESD wrist strap supplied with the FRUs, open the wrist strap package and unwrap the ESD wrist strap. Place the black conductive loop over your wrist and tighten the strap so that it makes good contact with your bare skin.
 - If you are using an ESD wrist strap equipped with an alligator clip, open the package and remove the ESD wrist strap. Locate the end of the wrist strap that attaches to your body and secure it to your bare skin.
- Step 2** Grasp the spring or alligator clip on the ESD wrist strap and momentarily touch the clip to a bare metal spot (unpainted surface) on the rack. We recommend that you touch the clip to an unpainted rack rail so that any built-up static charge is then safely dissipated to the entire rack.
- Step 3** Attach either the spring clip or the alligator clip to the ground lug screw as follows (see [Figure 4-1](#) and [Figure 4-2](#)):
- If you are using the ESD wrist strap that is supplied with the FRUs, squeeze the spring clip jaws open, position the spring clip to one side of the system ground lug screw head, and slide the spring clip over the lug screw head so that the spring clip jaws close behind the lug screw head.

**Note**

The spring clip jaws do not open wide enough to fit directly over the head of the lug screw or the lug barrel.

- If you are using an ESD wrist strap that is equipped with an alligator clip, attach the alligator clip directly over the head of the system ground lug screw or to the system ground lug barrel.
-

Figure 4-1 shows how to attach the ESD wrist strap to the system ground lug screw for the Cisco Nexus 2000 Series FEX.

Figure 4-1 Attaching the ESD Wrist Strap to the System Ground Lug Screw for a Cisco Nexus 2000 Series FEX

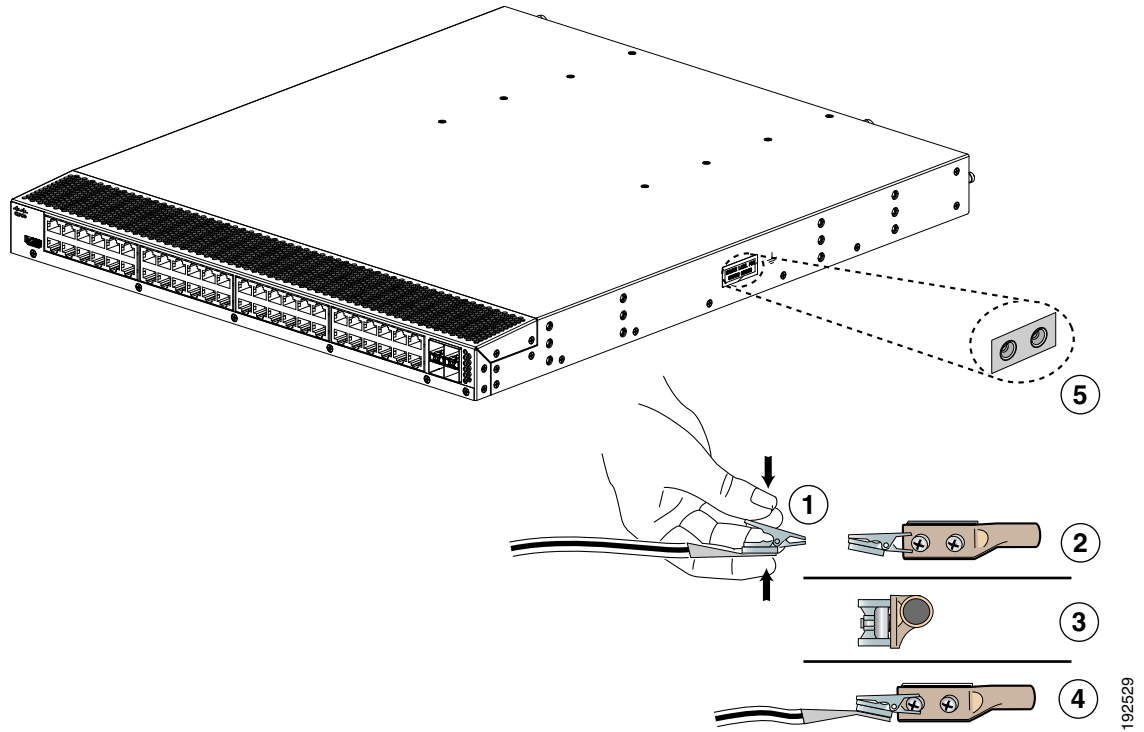

1	ESD ground strap	4	Clip installed (behind screw)
2	Clip and grounding lug	5	System ground connector
3	Side view of grounding lug (clip slid behind screw)		

 **Note**

For the Cisco Nexus 2300 Series FEX, the ground lug holes have been moved from the side to the rear of the system. Figure 4-2. shows the Cisco Nexus 2348UPQ FEX.

Figure 4-2 Cisco Nexus 2300 Series FEX Ground Lug Location

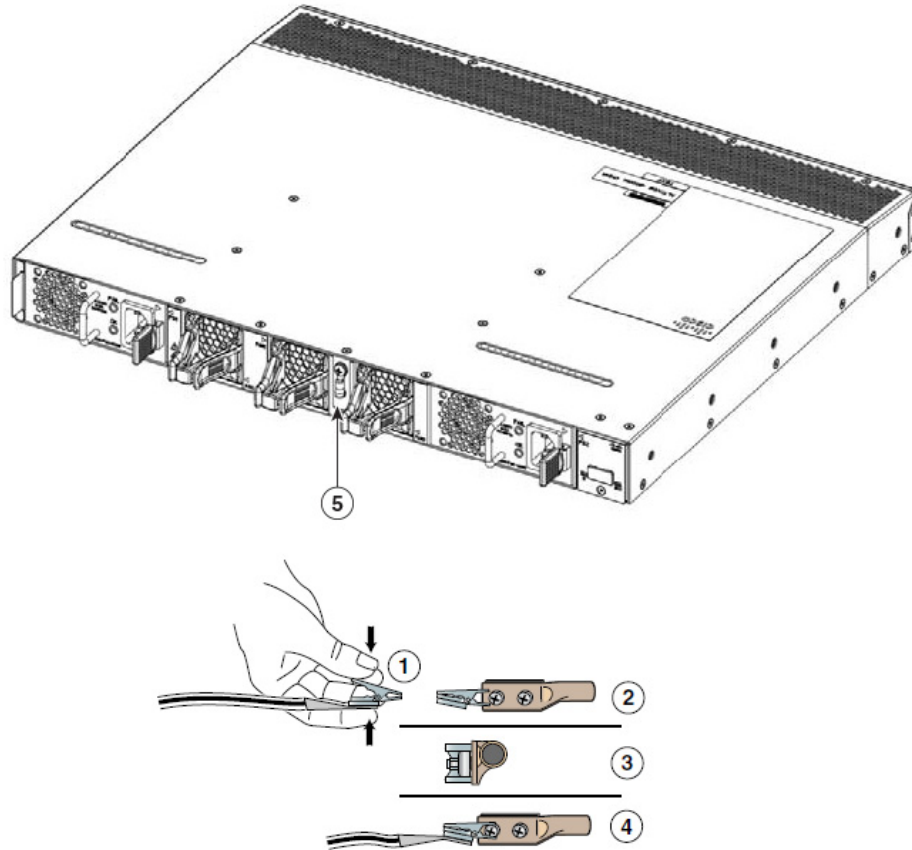

35.3654

1	ESD ground strap	4	Clip installed (behind screw)
2	Clip and grounding lug	5	Ground Lug
3	Side view of grounding lug (clip slid behind screw)		

In addition, follow these guidelines when handling these devices:

- Handle carriers by available handles or edges only; avoid touching the printed circuit boards or connectors.
- Place a removed component board-side-up on an antistatic surface or in a static-shielding container. If you plan to return the component to the factory, immediately place it in a static-shielding container.
- Never attempt to remove the printed circuit board from the metal carrier.

Caution

For safety, periodically check the resistance value of the antistatic strap. The measurement should be between 1 and 10 megohm (Mohm).

Establishing the System Ground

This section describes how to connect a system ground to the Cisco Nexus 2000 and 2300 Series FEXs.

**Note**

This system ground is also referred to as the network equipment building system (NEBS) ground.

You must use the system (NEBS) ground on AC-powered systems if you are installing this equipment in a U.S. or European Central Office.

The system (NEBS) ground provides additional grounding for EMI shielding requirements and grounding for the low-voltage supplies (DC-DC converters) on the devices and is intended to satisfy the Telcordia Technologies NEBS requirements for supplemental bonding and grounding connections. You must observe the following system grounding guidelines for your chassis:

- You must install the system (NEBS) ground connection with any other rack or system power ground connections that you make. The system ground connection is required if this equipment is installed in a U.S. or European Central Office.
- You must connect both the system (NEBS) ground connection and the power supply ground connection to an earth ground. The system (NEBS) ground connection is required if this equipment is installed in a U.S. or European Central Office.
- You do not need to power down the chassis because the Cisco Nexus FEX is equipped with AC-input power supplies.

Required Tools and Equipment

To connect the system ground, you need the following tools and materials:

- Grounding lug—A two-hole standard barrel lug that supports up to 6 AWG wire. This lug is supplied as part of accessory kit.
- Grounding screws—Two M4 x 8mm (metric) pan-head screws. The screws are supplied as part of the accessory kit.
- Grounding wire—Not supplied as part of the accessory kit. The grounding wire should be sized according to local and national installation requirements. Depending on the power supply and system, a 12 AWG to 6 AWG copper conductor is required for U.S. installations. Commercially available 6 AWG wire is recommended. The length of the grounding wire depends on the proximity of the device to proper grounding facilities.
- No. 1 Phillips screwdriver.
- Crimping tool to crimp the grounding wire to the grounding lug.
- Wire-stripping tool to remove the insulation from the grounding wire.

Grounding the Chassis

The chassis has a grounding pad with two threaded M4 holes for attaching a grounding lug.



Warning

When installing or replacing the unit, the ground connection must always be made first and disconnected last. Statement 1046



Caution

We recommend that you ground the chassis, even if the rack is already grounded.



Caution

You must ground all power supplies. The receptacles of the AC power cables used to provide power to the chassis must be the grounding type, and the grounding conductors should connect to protective earth ground at the service equipment.



Warning

When installing or replacing the unit, the ground connection must always be made first and disconnected last.

Statement 1046



Caution

Grounding the chassis is required if you are using DC power supplies, even if the rack is already grounded. A grounding pad with two threaded M4 holes is provided on the chassis for attaching a grounding lug. The ground lug must be NRTL listed. In addition, the copper conductor (wires) must be used and the copper conductor must comply with the NEC code.

To attach the grounding lug and cable to the chassis, follow these steps:

- Step 1** Use a wire-stripping tool to remove approximately 0.75 inches (19 mm) of the covering from the end of the grounding cable.
- Step 2** Insert the stripped end of the grounding cable into the open end of the grounding lug.
- Step 3** Use the crimping tool to secure the grounding cable in the grounding lug.
- Step 4** Remove the adhesive label from the grounding pad on the chassis.
- Step 5** Place the grounding lug against the grounding pad so that there is solid metal-to-metal contact, and insert the two M4 screws with washers through the holes in the grounding lug and into the grounding pad.
- Step 6** Ensure that the lug and cable do not interfere with other equipment.
- Step 7** Prepare the other end of the grounding cable and connect it to an appropriate grounding point in your site to ensure adequate earth ground.

Starting the Cisco Nexus Fabric Extender

This section describes how to power up the device and verify the hardware operation.

**Note**

Do not connect the Ethernet port to the LAN until the initial device configuration has been performed. For instructions on configuring the device, see the *Cisco Nexus 2300 Series Fabric Extender Software Configuration Guide*. For instructions on connecting to the console port, see the [“Connecting to the 1-Gigabit Ethernet Port”](#) section on page 5-2.

**Warning**

When installing or replacing the unit, the ground connection must always be made first and disconnected last.

Statement 1046

To power up the device and verify the hardware operation, follow these steps:

Step 1 Verify that the empty power supply bays have filler panels installed, the faceplates of all modules are flush with the port side exhaust of the chassis, and the captive screws of the power supplies, fan tray, and all expansion modules are tight.

Step 2 Verify that the power supply and the fan trays are installed.

**Note**

Depending on the outlet receptacle on your power distribution unit, you may need the optional jumper power cord to connect the Cisco Nexus 2000 Series FEX to your outlet receptacle. See the [“Jumper Power Cord”](#) section on page C-8.

Step 3 Ensure that the device is adequately grounded as described in the [“Grounding the System”](#) section on page 4-7.

Step 4 If you are installing an AC power supply, connect the power supply to an AC power source as follows:

- Plug the power cable into the power receptacle on the power supply.
- Attach the other end of the power cable to the AC power source.
- If you are connecting cables to a Cisco Nexus 2148T power supply, flip the switch above the AC receptacle on the power supply to ON.
- Verify that the power supply is functioning by making sure that the OK LED turns green and the FAULT LED is off.

Step 5 If you are installing a DC power supply, connect the power supply to a DC power source as follows:

- Make sure that the DC power source is turned off at the circuit breaker.
- Connect a negative cable from the power source to the positive (+) terminal on the power supply and fasten with the screw from that terminal.
- Connect a positive cable from the power source to the negative (-) terminal on the power supply and fasten with the screw from that terminal.
- Turn on the power at the circuit breaker.
- Verify that the power supply is functioning by making sure that the OK LED turns green and the FAULT LED is off.

Step 6 Listen for the fans; they should begin operating when the power cable is plugged in.

- Step 7** After the device boots, verify that the LED operation is as follows:
- Power supply—The system status LED is green.
 - After initialization, the system status LED is green, indicating that all chassis environmental monitors are reporting that the system is operational. If this LED is orange or red, one or more environmental monitor is reporting a problem.
 - The Link LEDs for the Ethernet connector should not be on unless the cable is connected.

If a component is not operating correctly, remove and reinstall that component. If it still does not operate correctly, contact your customer service representative for a replacement.



Note If you purchased this product through a Cisco reseller, contact the reseller directly for technical support. If you purchased this product directly from Cisco, contact Cisco Technical Support at this URL: http://www.cisco.com/en/US/support/tsd_cisco_worldwide_contacts.html.

- Step 8** Verify that the system software has booted and the device has initialized without error messages. If you cannot resolve an issue, contact your customer service representative.
- Step 9** Complete the worksheets provided in “Site Preparation and Maintenance Records” for future reference.

Removing and Installing Components

This section describes how to remove and install components on the Cisco Nexus 2000 and 2300 Series FEXs.

This section includes the following topics:

- [Removing and Installing Power Supplies, page 4-16](#)
- [Removing and Installing a Fan, page 4-19](#)
- [Removing and Installing the Fan Tray, page 4-21](#)
- [Removing the Cisco Nexus Fabric Extender, page 4-22](#)



Caution

To prevent ESD damage, wear grounding wrist straps during these procedures and handle modules by the carrier edges only.

Removing and Installing Power Supplies

The Cisco Nexus 2000 Series FEX supports two power supplies, but the FEX uses only one power supply for operations. The other power supply is for redundancy.



Caution

Whenever you replace a power supply, make sure that it has the same direction of airflow as the rest of the module in the switch (all fan tray and power supply modules must have the same direction of airflow and the same color designation for the airflow direction or else the switch can over heat and shut down).

**Note**

If you power up a FEX with power supply and fan tray modules that have different directions of airflow, an error condition will occur and the switch can over heat and shut down. With this error condition, you must shut down the switch to replace the modules that do not take in cool air from the cold aisle. After you ensure that all of the modules have the same direction of airflow and that they take in cooling air from the cold aisle, you can power up the FEX.

This section includes the following topics:

- [Removing an AC Power Supply, page 4-17](#)
- [Installing an AC Power Supply, page 4-17](#)
- [Removing a DC Power Supply, page 4-18](#)
- [Installing a DC Power Supply, page 4-19](#)

**Note**

You can replace a faulty power supply while the system is operating if the other power supply is functioning.

Removing an AC Power Supply

**Caution**

If you are using the Cisco Nexus 2000 or 2300 Series FEX with one power supply, removing the power supply causes the device to shut down. If you are using two power supplies and you remove one of them, the device continues to operate.

To remove an AC power supply, follow these steps:

- Step 1** Pull the power cord out from the power receptacle on the power supply.
- Step 2** Release the power supply from the chassis as follows:
 - If you are removing a power supply from a Cisco Nexus 2148T chassis, loosen the captive screw and then pull the power supply part way out of the chassis.
 - If you are removing a power supply from a Cisco Nexus 2248T, 2232PP, or 2224TP chassis, push and hold the thumb latch to the left and pull the power supply part way out of the chassis.
- Step 3** Place your other hand under the power supply to support it while you slide it out of the chassis.
- Step 4** If the power supply bay is to remain empty, install a blank power supply filler panel.

Installing an AC Power Supply

**Caution**

Be sure that the power supply that you are installing has the same airflow direction as the fan tray module and the other power supply. Either all of the modules must have port-side exhaust airflow (blue or no color on the front of the module) or all of the modules must have port-side intake airflow (red or black color on the front of the module). To prevent over heating, the switch does not support more than one airflow direction for the modules in the chassis.

To install a power supply, follow these steps:

-
- Step 1** Ensure that the system (earth) ground connection has been made for the chassis. For ground connection instructions, see the [“Grounding the System” section on page 4-7](#).
- Step 2** If the power supply bay has a filler panel, remove it from the slot as follows:
- If you are removing a filler panel from a Cisco Nexus 2248TP, 2232PP, or 2224TP FEX, push its thumb latch to the left and pull the panel out of the chassis.
 - If you are removing a filler panel from a Cisco Nexus 2148T FEX, loosen its captive screw, and then pull the panel out of the power supply bay.
- Step 3** Hold the replacement power supply by its handle and position it so that the captive screw is on the left, and then slide it into the power supply bay, ensuring that the power supply is fully seated in the bay.
- Step 4** Secure the power supply to the chassis as follows:
- If you are installing a Cisco Nexus 2248TP, 2232PP, or 2224TP FEX, make sure that the thumb latch engages with the chassis so that the power supply is held in the slot.
 - If you are installing a Cisco Nexus 2148T, fasten the power supply to the chassis by screwing its captive screw into its hole in the chassis and tightening it.



Note Depending on the outlet receptacle on your power distribution unit, you may need the optional jumper power cord to connect the Cisco Nexus 2000 Series FEX to your outlet receptacle. See the [“Jumper Power Cord” section on page C-8](#).

- Step 5** Connect the other end of the power cable to an AC power source.



Caution In a system with dual power supplies, connect each power supply to a separate power source. If a power source failure occurs, the second source will most likely still be available.

- Step 6** Verify power supply operation by checking that the power supply LED is green. For information about what the power supply LEDs indicate, see the [“Power Supply Status” section on page E-3](#).
-

Removing a DC Power Supply



Caution If you are using the Cisco Nexus 2200 platform FEX with one DC power supply, removing the power supply causes the device to shut down. If you are using two power supplies and you remove one of them, the device continues to operate.

To remove a DC power supply, follow these steps:

-
- Step 1** Shut off the DC power to the power supply at the circuit breaker. Make sure that both LEDs are off.
- Step 2** Unfasten the positive power cable from the negative (-) terminal.
- Step 3** Unfasten the negative power cable from the positive (+) terminal.
- Step 4** Press the thumb latch to disengage the power supply from the chassis and use the handle to pull it part way out of the chassis.

- Step 5** Place your other hand under the power supply to support it while you slide it out of the chassis. Place the power supply on an antistatic surface.
- Step 6** If the power supply bay is to remain empty, install a blank power supply filler panel.
-

Installing a DC Power Supply

In a system with dual power supplies, connect each power supply to a separate power source. If a power source failure occurs, the second source will most likely still be available.



Caution

Be sure that the power supply that you are installing has the same airflow direction as the fan tray module and the other power supply. Either all of the modules must have port-side exhaust airflow (blue or no color on the front of the module) or all of the modules must have port-side intake airflow (red or black color on the front of the module). To prevent over heating, the switch does not support more than one airflow direction for the chassis.

To install a power supply, follow these steps:

- Step 1** Ensure that the system (earth) ground connection has been made for the chassis. For ground connection instructions, see the [“Grounding the System” section on page 4-7](#).
- Step 2** If the power supply bay has a filler panel, push and hold the thumb latch to the left, and then slide the filler panel out of the power supply bay.
- Step 3** Hold the replacement power supply by the handle and position it so that the thumb latch is on the right, and then slide it into the power supply bay, ensuring that the power supply is fully seated in the bay.
- Step 4** Engage the thumb latch so that the power supply is firmly held in place in its slot.
- Step 5** Fasten the positive cable to the negative (-) terminal.
- Step 6** Fasten the negative cable to the positive (+) terminal.
- Step 7** Turn on the power at the circuit breaker.
- Step 8** Verify power supply operation by checking that the power supply LED is green. For information about what the power supply LEDs indicate, see the [“Power Supply Status” section on page E-3](#).
-

Removing and Installing a Fan

The Cisco Nexus 2300 Series FEXs support three fans, but the FEX needs only two fans for operation. The other fan is for redundancy. Individual fans are designed to be removed and replaced while the system is operating, without causing an electrical hazard or damage to the system.

If you are replacing a fan tray on a Cisco Nexus 2200 Series FEX, or Cisco Nexus 2148T FEX, see the [“Removing and Installing the Fan Tray” section on page 4-21](#).

**Caution**

Be sure that the fan that you are installing has the same airflow direction as the other fans and power supply modules in the same chassis. Either all of the modules must have port-side exhaust airflow (a blue or no color on the front of the module) or all of the modules must have port-side intake airflow (red or black color on the front of the module). If the modules have different airflow directions in the same chassis, an error condition occurs, the switch can over heat, and the switch can shut down.

**Note**

If you power up a FEX with power supply and fan modules that have different directions of airflow, an error condition will occur and the switch can over heat and shut down. With this error condition, you must shut down the switch to replace the modules that do not take in cool air from the cold aisle. After you ensure that all of the modules have the same direction of airflow and take in cooling air from the cold aisle, you can power up the FEX.

This section includes the following topics:

- [Removing a Fan, page 4-20](#)
- [Installing a Fan, page 4-20](#)

Removing a Fan

**Warning**

When removing the fan tray, keep your hands and fingers away from the spinning fan blades. Let the fan blades completely stop before you finish removing the fan tray. Statement 258

To remove a fan, follow these steps:

- Step 1** Pinch the two protruding tabs of the fan towards each other to release the latch and pull the fan outward.
- Step 2** Pull the fan clear of the chassis and set it on an antistatic surface or repack it in packing materials.

Installing a Fan

To install a fan, follow these steps:

- Step 1** Place the fan into the port-side exhaust chassis cavity so it rests on the chassis, and then push the fan into the chassis as far as it can go until it is latched in place.
- Step 2** Listen for the fan if the device is powered on. You should immediately hear it operating. If you do not hear it, ensure that the fan is inserted completely in the chassis and the faceplate is flush with the outside surface of the chassis.
- Step 3** Verify that the LED is green. If the LED is not green, the fan is faulty. If this problem occurs, contact your customer service representative for a replacement part.

**Note**

If you purchased this product through a Cisco reseller, contact the reseller directly for technical support. If you purchased this product directly from Cisco, contact Cisco Technical Support at this URL: <http://www.cisco.com/c/en/us/support/web/tsd-cisco-worldwide-contacts.html>.

Removing and Installing the Fan Tray

The Cisco Nexus 2200 Series FEXs, and Cisco Nexus 2148T FEX, use a fan tray. The fan tray is designed to be removed and replaced while the system is operating without causing an electrical hazard or damage to the system, if the replacement is performed within 1 minute.

**Caution**

Be sure that the fan tray that you are installing has the same airflow direction as the other fan tray and power supply modules in the same chassis. Either all of the modules must have port-side exhaust airflow (a blue or no color on the front of the module) or all of the modules must have port-side intake airflow (red or black color on the front of the module). If the modules have different airflow directions in the same chassis, an error condition occurs, the switch can over heat, and the switch can shut down.

**Note**

If you power up a FEX with power supply and fan tray modules that have different directions of airflow, an error condition will occur and the switch can over heat and shut down. With this error condition, you must shut down the switch to replace the modules that do not take in cool air from the cold aisle. After you ensure that all of the modules have the same direction of airflow and take in cooling air from the cold aisle, you can power up the FEX.

This section includes the following topics:

- [Removing a Fan Tray, page 4-21](#)
- [Installing a Fan Tray, page 4-22](#)

Removing a Fan Tray

**Warning**

When removing the fan tray, keep your hands and fingers away from the spinning fan blades. Let the fan blades completely stop before you finish removing the fan tray. Statement 258

To remove a fan tray, follow these steps:

- Step 1** Loosen the captive screws on the fan tray by turning them counterclockwise, using a flat-blade or number 2 Phillips screwdriver if required.
- Step 2** Grasp the captive screws of the fan tray and pull it outward.
- Step 3** Pull the fan tray clear of the chassis and set it on an antistatic surface or repack it in packing materials.



Note If you remove a fan tray while the system is running, you must install the new fan tray within 1 minute to prevent overheating.

Installing a Fan Tray

To install a fan tray, follow these steps:

-
- Step 1** Hold the fan tray with the sheet metal flange holding the connector on the bottom.
 - Step 2** Place the fan tray into the port-side exhaust chassis cavity so it rests on the chassis, and then push the fan tray into the chassis as far as it can go until the captive screw makes contact with the chassis.
 - Step 3** Tighten the captive screw.
 - Step 4** Listen for the fans if the device is powered on. You should immediately hear them operating. If you do not hear them, ensure that the fan tray is inserted completely in the chassis and the faceplate is flush with the outside surface of the chassis.
 - Step 5** Verify that the LED is green. If the LED is not green, one or more fans are faulty. If this problem occurs, contact your customer service representative for a replacement part.



Note If you purchased this product through a Cisco reseller, contact the reseller directly for technical support. If you purchased this product directly from Cisco, contact Cisco Technical Support at this URL: <http://www.cisco.com/c/en/us/support/web/tsd-cisco-worldwide-contacts.html>.

Removing the Cisco Nexus Fabric Extender



Caution The slider rail and port side exhaust rack-mount brackets do not have a stop mechanism when sliding in and out. If the port side exhaust of the chassis is unfastened from the rack and the chassis slides forward on the slider rails, it may slip off the end of the rails and fall out of the rack.

To remove the Cisco Nexus 2000 Series FEX from a rack, follow these steps:

-
- Step 1** Ensure that the weight of the FEX is fully supported and that the device is being held by another person.
 - Step 2** Turn off the power at the circuit breaker.
 - Step 3** Disconnect the power cord as follows:
 - For AC power supplies, disconnect the power cord and the console cables.
 - For DC power supplies, disconnect the positive cable from the negative (-) terminal, and disconnect the negative cable from the positive (+) terminal.
 - Step 4** Disconnect all ports.
 - Step 5** Remove the screws that fasten the port side exhaust rack-mount brackets to the mounting rails.

Step 6 Gently slide the chassis toward you, off of the slider rails and out of the rack.

Repacking the Cisco Nexus Fabric Extender for Return Shipment

If you need to return the Cisco Nexus 2000 and 2300 Series FEX, remove the device from the rack by following the steps in the [“Removing the Cisco Nexus Fabric Extender”](#) section on page 4-22, and repack it for shipment. If possible, use the original packing materials and container to repack the device. Contact your Cisco customer service representative to arrange for return shipment to Cisco.



Connecting a Cisco Nexus Fabric Extender

This chapter describes how to connect the ports on a Cisco Nexus Fabric Extender (FEX).



Caution

When running power and data cables in overhead or subfloor cable trays, we strongly recommend that you have power cables and other potential noise sources as far away as practical from network cabling that terminates on Cisco equipment. In situations where long parallel cable runs cannot be separated by at least 3.3 feet (1 m), we recommend that you shield any potential noise sources by housing them in a grounded metallic conduit.

This chapter includes the following sections:

- [Preparing for Network Connections, page 5-2](#)
- [Connecting to the 1-Gigabit Ethernet Port, page 5-2](#)
- [Connecting to a 10-Gigabit and 40-Gigabit Ethernet Port, page 5-2](#)

Preparing for Network Connections

When preparing your site for network connections to the Cisco Nexus FEX, consider the following for each type of interface, and gather all the required equipment before connecting the ports:

- Cabling required for each interface type
- Distance limitations for each signal type
- Additional interface equipment required

Connecting to the 1-Gigabit Ethernet Port

This section describes how to connect a 1-Gigabit Ethernet port to a host.

The 1-Gigabit Ethernet ports have RJ-45 interfaces. There are 48 1-Gigabit Ethernet server ports.

To connect a 1-Gigabit Ethernet port to a host, follow these steps:

-
- Step 1** Connect the appropriate modular cable to the 1-Gigabit Ethernet port.
- Step 2** Connect the other end of the cable to the device.
-

Connecting to a 10-Gigabit and 40-Gigabit Ethernet Port

This section describes how to connect a 10-Gigabit or 40-Gigabit Ethernet port to a host. There are four network facing 10-Gigabit Ethernet ports for the Cisco Nexus 2148T and 2248TP, eight for the Cisco Nexus 2232TM, 2232TM-E, and 2232PP, and two on the Cisco Nexus 2224TP. An SFP+ transceiver is used to connect to a 10-Gigabit Ethernet port. The Cisco Nexus 2300 Series platform FEXs provide six network facing 40-Gigabit uplink ports. A QSFP+ transceiver is used to connect to a 40-Gigabit Ethernet port.

This section includes the following topics:

- [Removing and Installing SFP+ Transceivers, page 5-2](#)
- [Removing and Installing Cables into SFP+ Transceivers, page 5-4](#)
- [Maintaining SFP+ Transceivers and Cables, page 5-6](#)

Removing and Installing SFP+ Transceivers



Caution

Excessively removing and installing an SFP transceiver can shorten its life. Do not remove and insert SFP+ transceivers more often than is necessary. We recommend that you disconnect cables before installing or removing SFP transceivers to prevent damage to the cable or transceiver.

This section describes how to install and remove an SFP+ transceiver. This section includes the following topics:

- [Installing an SFP+ Transceiver, page 5-3](#)

- [Removing an SFP+ Transceiver, page 5-3](#)

Installing an SFP+ Transceiver

To install an SFP+ transceiver, follow these steps:

-
- Step 1** Attach an ESD-preventive wrist strap and follow its instructions for use.
- Step 2** Remove the dust cover from the port cage.
- Step 3** Remove the dust cover from the port end of the transceiver.
- Step 4** Insert the transceiver into the port as follows:
- If the transceiver has a Mylar tab latch, position the transceiver with the tab on the bottom, and then gently insert the transceiver into the port until it clicks into place.
 - If the transceiver has a bale clasp latch, position the transceiver with the clasp on the bottom, close the clasp by pushing it up over the transceiver, and then gently insert the transceiver into the port until it clicks into place.



Caution If the transceiver does not install easily, ensure that it is correctly positioned and the tab or clasp are in the correct position before continuing.



Note If you cannot install the cable into the transceiver, insert or leave the dust cover in the cable end of the transceiver.

Removing an SFP+ Transceiver

To remove an SFP+ transceiver, follow these steps:

-
- Step 1** Attach an ESD-preventive wrist strap and follow its instructions for use.
- Step 2** If a cable is installed in the transceiver, do one of the following:
- a. Record the cable and port connections for later reference.
 - b. Press the release latch on the cable, grasp the connector near the connection point, and gently pull the connector from the transceiver.
 - c. Insert a dust plug into the cable end of the transceiver.



Caution If the transceiver does not remove easily in the next step, push the transceiver completely in and then ensure that the latch is in the correct position before continuing.

- Step 3** Remove the transceiver from the port as follows:
- If the transceiver has a Mylar tab latch, gently pull the tab straight out (do not twist), and then pull the transceiver out of the port.

- If the transceiver has a bale clasp latch, open the clasp by pressing it downward, and then pull the transceiver out of the port.



Note If you have difficulty removing a bale clasp SFP+ transceiver, you should reseal it by returning the bale clasp to the up position. Press the SFP+ transceiver inward and upward into the cage. Next, lower the bale clasp and pull the SFP+ transceiver straight out with a slight upward lifting force (see [Figure 5-1](#)). Be careful not to damage the port cage during this process.

Figure 5-1 Alternate Removal Method for Bale Clasp SFP+ Transceivers

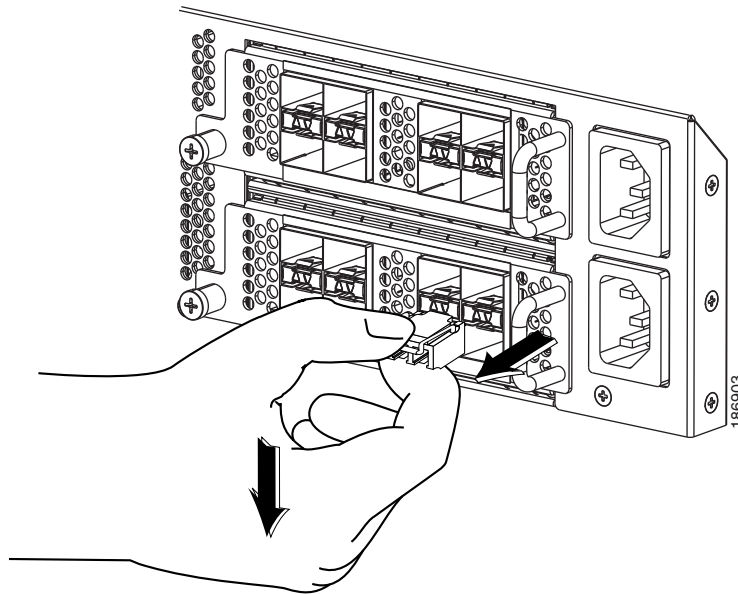

- Step 4** Insert a dust cover into the port end of the transceiver and place the transceiver on an antistatic mat or into a static shielding bag if you plan to return it to the factory.
- Step 5** If another transceiver is not being installed, protect the optical cage by inserting a clean cover.

Removing and Installing Cables into SFP+ Transceivers

This section describes how to remove and install cables into and from SFP+ transceivers.



Caution

To prevent damage to the copper cables, do not place more tension on them than the rated limit and do not bend to a radius of less than 1 inch if there is no tension in the cable, or 2 inches if there is tension in the cable.

This section includes the following topics:

- [Installing a Cable into an SFP+ Transceiver, page 5-5](#)
- [Removing a Cable from an SFP+ Transceiver, page 5-5](#)

Removing a Cable from an SFP+ Transceiver

**Caution**

When pulling a cable from a transceiver, grip the body of the connector. Do not pull on the jacket sleeve, because this action can compromise the fiber-optic termination in the connector.

**Caution**

If the cable does not remove easily, ensure that any latch present on the cable has been released before continuing.

To remove the cable, follow these steps:

- Step 1** Attach an ESD-preventive wrist strap and follow its instructions for use.
- Step 2** Press the release latch on the cable, grasp the connector near the connection point, and gently pull the connector from the transceiver.
- Step 3** Insert a dust plug into the cable end of the transceiver.
- Step 4** Insert a dust plug onto the end of the cable.

Installing a Cable into an SFP+ Transceiver

**Caution**

To prevent possible damage to the cable or transceiver, install the transceiver in the port before installing the cable in the transceiver.

To install a cable into a transceiver, follow these steps:

- Step 1** Attach an ESD-preventive wrist strap and follow its instructions for use.
- Step 2** Remove the dust cover from the connector on the cable.
- Step 3** Remove the dust cover from the cable end of the transceiver.
- Step 4** Align the cable connector with the transceiver and insert the connector into the transceiver until it clicks into place.

**Caution**

If the cable does not install easily, ensure that it is correctly positioned before continuing.

For instructions on verifying connectivity, see the *Cisco Nexus 2000 Series Fabric Extender Software Configuration Guide*.

Maintaining SFP+ Transceivers and Cables

You must keep SFP+ transceivers clean and dust free to maintain high signal accuracy and prevent damage to the connectors. Attenuation (loss of light) is increased by contamination and should be below 0.35 dB.

Follow these maintenance guidelines:

- SFP+ transceivers are static sensitive. To prevent ESD damage, wear an ESD-preventive wrist strap that is connected to the chassis.
- Do not remove and insert a transceiver more often than is necessary. Repeated removals and insertions can shorten its life.
- Keep all optical connections covered when not in use. If they become dusty, clean before using to prevent dust from scratching the fiber-optic cable ends.
- Do not touch ends of connectors to prevent fingerprints and other contamination.
- Clean regularly; the required frequency of cleaning depends upon the environment. In addition, clean connectors if they are exposed to dust or accidentally touched. Both wet and dry cleaning techniques can be effective; refer to your site's fiber-optic connection cleaning procedure.
- Inspect routinely for dust and damage. If damage is suspected, clean and then inspect fiber ends under a microscope to determine if damage has occurred.



Cabinet and Rack Installation

This appendix provides the requirements for cabinet and rack installation and includes the following sections:

- [Cabinet and Rack Requirements, page A-1](#)
- [Cable Management Guidelines, page A-3](#)

Cabinet and Rack Requirements

This section provides the requirements for the following types of cabinets and racks, assuming an external ambient air temperature range of 0 to 104°F (0 to 40°C):

- Standard perforated cabinets
- Solid-walled cabinets with a roof fan tray (bottom to top cooling)
- Standard open racks



Note

If you are selecting an enclosed cabinet, we recommend one of the thermally validated types, either standard perforated or solid-walled with a fan tray.



Note

Do not use racks that have obstructions (such as power strips), because the obstructions could impair access to field-replaceable units (FRUs).

This section includes the following topics:

- [General Requirements for Cabinets and Racks, page A-1](#)
- [Requirements Specific to Perforated Cabinets, page A-2](#)
- [Requirements Specific to Standard Open Racks, page A-2](#)

General Requirements for Cabinets and Racks

The cabinet or rack must be one of the following types:

- Standard 19-in. (48.3 cm) (four-post EIA cabinet or rack, with mounting rails that conform to English universal hole spacing per section 1 of ANSI/EIA-310-D-1992). See the [“Requirements Specific to Perforated Cabinets”](#) section on page A-2.

The cabinet or rack must also meet the following requirements:

- The minimum vertical rack space per Cisco Nexus 2000 Series FEX chassis or Cisco Nexus 2300 Series FEX chassis must be one RU (rack units), equal to 1.75 inches (4.4 cm).
- The width between the rack-mounting rails must be at least 17.75 inches (45.0 cm) if the rear of the device is not attached to the rack. For four-post EIA racks, this measurement is the distance between the two port side exhaust rails.
- For four-post EIA cabinets (perforated or solid-walled), the requirements are as follows:
 - The minimum spacing for the bend radius for fiber-optic cables should have the port side exhaust-mounting rails of the cabinet offset from the port side exhaust door by a minimum of 3 inches (7.6 cm).
 - The distance between the outside face of the port side exhaust mounting rail and the outside face of the back mounting rail should be 23.0 to 30.0 inches (58.4 to 76.2 cm) to allow for rear-bracket installation.
 - A minimum of 2.5 inches (6.4 cm) of clear space should exist between the side edge of the chassis and the side wall of the cabinet. No sizeable flow obstructions should be immediately in the way of chassis air intake or exhaust vents.



Note Optional jumper power cords are available for use in a cabinet. See the [“Jumper Power Cord” section on page C-8](#).

Requirements Specific to Perforated Cabinets

A perforated cabinet is defined as a cabinet with perforated port side exhaust and rear doors and solid side walls. In addition to the requirements listed in the [“General Requirements for Cabinets and Racks” section on page A-1](#), perforated cabinets must meet the following requirements:

- The port side exhaust and rear doors must have at least a 60 percent open area perforation pattern with at least 15 square inches (96.774 square cm) of open area per rack unit of door height.
- The roof should be perforated with at least a 20 percent open area.
- The cabinet floor should be open or perforated to enhance cooling.

The Cisco R Series rack conforms to these requirements.

Requirements Specific to Standard Open Racks

In addition to the requirements listed in the [“General Requirements for Cabinets and Racks” section on page A-1](#), if mounting the chassis in an open rack (no side panels or doors), ensure that the rack meets the following requirements:

- The minimum vertical rack space per chassis must be two rack units (RU), equal to 3.47 inches (8.8 cm).
- The horizontal distance between the chassis and any adjacent chassis should be 6 inches (15.2 cm), and the distance between the chassis air vents and any walls should be 2.5 inches (6.4 cm).

Cable Management Guidelines

To help with cable management, you might want to allow additional space in the rack above and below the chassis to make it easier to route as many as 56 fiber or copper cables through the rack.



Technical Specifications

This appendix describes the technical specifications for the Cisco Nexus Fabric Extenders (FEXs) and includes the following sections:

- [Power Specifications, page B-1](#)
- [Environmental Specifications, page B-6](#)
- [Physical Specifications, page B-6](#)
- [Transceiver Specifications, page B-7](#)
- [Airflow Optimization Accessories, page B-9](#)



Note

Specifications for cables and connectors are provided in [Appendix C, “Cable and Port Specifications.”](#)

Power Specifications

This section describes the power specifications for the Cisco Nexus Fabric Extenders.

The power supplies connect directly to the system through connectors attached to the baseboard through cables. One connector is on the baseboard for each power supply. AC input is through an IEC connector mounted on the power supply port side exhaust panel. [Table B-1](#) lists the specifications for the FEX power supplies.

Table B-1 Power Specifications for the Cisco Nexus Fabric Extender

Cisco Nexus Fabric Extender	Power Supply		
		N2K-PAC-200W	N2200-PAC-400W N2200-PAC-400W-B N2200-PDC-400W
FEXs	Cisco Nexus 2148T	Cisco Nexus 2348TQ and 2348UPQ, Cisco Nexus 2248TP-E, 2248TP, 2232PP, 2224TP, 2248PQ and 2232TM	Cisco Nexus 2348UPQ, Cisco Nexus 2248TP-E, 2248TP, 2232PP, 2248PQ and 2224TP
Typical Input Operating Power	165 W	187 W @ 30M, 239 W @ 100M to 300 W (Cisco Nexus 2348TQ) 125 W to 200 W (Cisco Nexus 2348UPQ) 110 W (Cisco Nexus 2248TP-E and 2248TP) 270 W (Cisco Nexus 2232PP) 350 W to 386 W (Cisco Nexus 2232TM)	110 W (Cisco Nexus 2248TP-E and 2248TP) 270 W (Cisco Nexus 2232PP) 95 W (Cisco Nexus 2224TP)
Maximum Output Power	200 W	400 W	350 W
Input Voltage	90 to 264 VAC	90 to 264 VAC N2K-PDC-400W: -40 to -72 VDC	-40 to -72 VDC
Frequency	50 to 60 Hz	50 to 60 Hz N2K-PDC-400W: N/A	N/A

Table B-1 Power Specifications for the Cisco Nexus Fabric Extender (continued)

	Power Supply		
Cisco Nexus Fabric Extender	N2K-PAC-200W	N2200-PAC-400W N2200-PAC-400W-B N2200-PDC-400W	N2200-PDC-350W-B
	Input Current	1.5 A/2.2 A* (typical/maximum) * The Input currents listed for 110 V; divide by two for 220 V	Cisco Nexus 2348TQ: 1.7 A/2.17 A* (typical/maximum) Cisco Nexus 2348UPQ: 1.14 A/1.82 A* (typical/maximum) Cisco Nexus 2248TP-E: 1.0 A/1.2 A* (typical/maximum) Cisco Nexus 2248TP: 1.0 A/1.2 A* (typical/maximum) Cisco Nexus 2232PP: 2.5 A/4.1 A* (typical/maximum) Cisco Nexus 2224TP: 0.75 A/0.9 A* (typical/maximum) Cisco Nexus 2232TM 3.18 A/3.51 A* (typical/maximum) * Input currents listed for 110 V; divide by two for 220 V

Table B-1 Power Specifications for the Cisco Nexus Fabric Extender (continued)

	Power Supply		
Cisco Nexus Fabric Extender	N2K-PAC-200W	N2200-PAC-400W N2200-PAC-400W-B N2200-PDC-400W	N2200-PDC-350W-B
Output Current	11.5 A/16.7 A (typical/maximum)	Cisco Nexus 2348TQ: 14.8 A/24.75 A (typical/maximum) Cisco Nexus 2348UPQ: 9.9 A/16.5 A (typical/maximum) Cisco Nexus 2248TP-E: 8 A/10 A (typical/maximum) Cisco Nexus 2248TP: 8 A/10 A (typical/maximum) Cisco Nexus 2232PP: 20 A/33 A (typical/maximum) Cisco Nexus 2224TP: 5 A/7 A (typical/maximum) Cisco Nexus 2232TM: 26 A/28.9 A (typical/maximum)	Cisco Nexus 2248TP-E: 8 A/10 A (typical/maximum) Cisco Nexus 2248TP: 8 A/10 A (typical/maximum) Cisco Nexus 2232PP: 20 A/33 A (typical/maximum) Cisco Nexus 2224TP: 5 A/7 A (typical/maximum)
Efficiency	84 percent at typical power draw	90/92 percent (110/240 Vin) at typical power draw 88/91 percent (110/240 Vin) at max power draw N2K-PDC-400 W: 88% (-48 Vin) at typical power draw 85% (-48 Vin) at maximum power draw	88% (-48Vin) at typical power draw 85% (-48Vin) at maximum power draw
RoHS Compliance	RoHS-5 compliant	RoHS-6 compliant	RoHS-6 compliant
Hot Swappable	Yes	Yes	Yes

Table B-1 Power Specifications for the Cisco Nexus Fabric Extender (continued)

	Power Supply		
Cisco Nexus Fabric Extender	N2K-PAC-200W	N2200-PAC-400W N2200-PAC-400W-B N2200-PDC-400W	N2200-PDC-350W-B
Heat Dissipation	670 BTU/hr	Cisco Nexus 2348TQ: 638/1023 BTU/hour (typical/maximum) Cisco Nexus 2348UPQ: 426/682 BTU/hour (typical/maximum) Cisco Nexus 2248TP-E: 322/403 BTU/hour (typical/maximum) Cisco Nexus 2248TP: 322/403 BTU/hour (typical/maximum) Cisco Nexus 2232PP: 806/1330 BTU/hour (typical/maximum) Cisco Nexus 2224TP: 202/282 BTU/hour (typical/maximum) Cisco Nexus 2232TM: 1176/1297 BTU/hour (typical/maximum)	Cisco Nexus 2248TP-E: 322/403 BTU/hour (typical/maximum) Cisco Nexus 2248TP: 322/403 BTU/hour (typical/maximum) Cisco Nexus 2232PP: 806/1330 BTU/hour (typical/maximum) Cisco Nexus 2224TP: 202/282 BTU/hour (typical/maximum)
Power Cord Rating	3 A @ 100 Vin / 1.5 A @ 240 Vin maximum	6 A @ 100 Vin / 3 A @ 240 Vin maximum N2K-PDC-400W: 15 A @ -48 Vin / 8 A @ -60 Vin maximum	15A @ -48Vin / 8A @ -60Vin maximum
Cubic Inches	51 in ³	39 in ³	39 in ³
Power Density	3.9 W/in ³	10.2 W/in ³	10.2 W/in ³
Operating Temperature	50°C	50°C	50°C
Cooling	Internal fans to cool the supply	Internal fans to cool the supply	Internal fans to cool the supply
Input connector	AC connector in the power supply face	AC connector in the power supply face	AC connector in the power supply face

Table B-1 Power Specifications for the Cisco Nexus Fabric Extender (continued)

	Power Supply		
Cisco Nexus Fabric Extender	N2K-PAC-200W	N2200-PAC-400W N2200-PAC-400W-B N2200-PDC-400W	N2200-PDC-350W-B
Output connector	DC output connector in the back	DC output connector in the back	DC output connector in the back
Supply Indicators	Supply Health: Green indicates the power supply is operational and red indicates a fault. AC good indicator: Solid green indicates that AC is present and is within the supply specifications.	Supply Health: Green indicates the power supply is operational and amber indicates a fault. AC good indicator: Solid green indicates that AC is present and is within the supply specifications.	Supply Health: Green indicates the power supply is operational and amber indicates a fault.

Environmental Specifications

Table B-2 lists the environmental specifications for a FEX.

Table B-2 Environmental Specifications for the Cisco Nexus Fabric Extender

Description	Specification
Temperature, operating	32 to 104°F (0 to 40°C); 32 to 131°F (0 to 55°C) for the Cisco Nexus 2348TQ and 2348UPQ
Temperature, nonoperating	−4 to 158°F (−20 to 70°C); −40 to 158°F (−40 to 70°C) for the Cisco Nexus 2348TQ and 2348UPQ
Humidity (RH), noncondensing	5 to 95%
Altitude	0 to 10000 ft (0 to 3000 m)

The Cisco Nexus 2348TQ, Cisco Nexus 2348UPQ, Cisco Nexus 2232PP, 2232TM, and the Cisco Nexus 2248TP-ETP FEXs can operate in a horizontal or vertical rack mount configuration.

Physical Specifications

Table B-3 lists the dimensions and weights for the Cisco Nexus Fabric Extenders.

Table B-3 Physical Specifications for Installing the Cisco Nexus Fabric Extender

Cisco Nexus Fabric Extender	Dimensions (Height x Width x Depth) ¹		Weight ²
	Inches	Centimeters	
Cisco Nexus 2348TQ chassis	1.72 x 17.3 x 17.07 in.	4.37 x 43.94 x 43.36 cm	17.0 lb (7.7 kg)
Power supply	—	—	2.2 lb (1.0 kg)
Fan tray	—	—	1.4 lb (0.6 kg)
Cisco Nexus 2348UPQ chassis	1.72 x 17.3 x 14.05 in.	4.37 x 43.94 x 35.69 cm	15.5 lb (7.0 kg)
Power supply	—	—	2.2 lb (1.0 kg)
Fan tray	—	—	1.4 lb (0.6 kg)
Cisco Nexus 2248TP-E chassis	1.72 x 17.3 x 17.7 in.	4.37 x 43.94 x 44.96 cm	17.7 lb (8.03 kg)
Power supply	—	—	2.2 lb (1.0 kg)
Fan tray	—	—	1.4 lb (0.6 kg)
Cisco Nexus 2248TP chassis	1.72 x 17.3 x 17.7 in.	4.37 x 43.94 x 44.96 cm	17.7 lb (8.03 kg)
Power supply	—	—	2.2 lb (1.0 kg)
Fan tray	—	—	1.4 lb (0.6 kg)
Cisco Nexus 2248PQ chassis	1.72 x 17.3 x 17.7 in.	4.37 x 43.94 x 44.96 cm	17.5 lb (8.0 kg)
Power supply	—	—	2.2 lb (1.0 kg)
Fan tray	—	—	1.8 lb (0.8 kg)
Cisco Nexus 2232PP chassis	1.72 x 17.3 x 17.7 in.	4.37 x 43.94 x 44.96 cm	18.3 lb (8.3 kg)
Power supply	—	—	2.2 lb (1.0 kg)
Fan tray	—	—	1.8 lb (0.8 kg)
Cisco Nexus 2224TP chassis	1.72 x 17.3 x 17.7 in.	4.37 x 43.94 x 44.96 cm	16.6 lb (1.0 kg)
Power supply	—	—	2.2 lb (1.0 kg)
Fan tray	—	—	1.4 lb (0.6 kg)
Cisco Nexus 2148T chassis	1.72 x 17.3 x 20.0 in.	4.37 x 43.94 x 50.8 cm	18.0 lb (8.2 kg)
Power supply	—	—	1.5 lb (0.7 kg)
Fan tray	—	—	1.5 lb (0.7 kg)
Cisco Nexus 2232TM chassis	1.72 x 17.3 x 17.7 in.	4.37 x 43.94 x 44.96 cm	18.5 lb (8.4 kg)
Power supply	—	—	2.2 lb (1.0 kg)
Fan tray	—	—	1.8 lb (0.8 kg)

1. Dimensions are presented for only the chassis rack size and service clearance requirements.
2. Combine the chassis, power supply, and fan tray weights for the overall weight of the switch to be installed. Remember to double the power supply weights if there are two power supplies installed in the FEX.

Transceiver Specifications

This section describes the transceiver specifications for the Cisco Nexus FEX. This section includes the following topics:

- [SFP+ Optical Transceiver Specifications, page B-8](#)

SFP+ Optical Transceiver Specifications

This section provides the general and environmental specifications for the SFP+ transceivers used with optical cables.

For the general specifications that apply to SFP+ transceivers, see [Table B-4](#). For the environmental specifications, see [Table B-5](#).

For information about Cisco 10GBASE SFP modules, refer to the [Cisco Transceiver Modules Datasheet](#).

Table B-4 SFP+ Transceiver General Specifications

Transceiver	Cable Type	Connector Type	Wavelength (nm)	Core Size (microns)	Modal Bandwidth (MHz-km)	Maximum Cable Distance
N2200 FET	MMF	Dual LC/PC	850	50	500	82 feet (25 meters)
				50	2000	328 feet (100 meters)
SFP-10G-SR	MMF	Dual LC/PC	850	62.5	160	85 feet (26 meters)
				62.5	200	108 feet (33 meters)
				50.0	400	216 feet (66 meters)
				50.0	500	269 feet (82 meters)
				50.0	2000	984 feet (984 meters)
SFP-10G-LR	SMF	Dual LC/PC	1310	G.652 fiber	—	6.2 miles (10 km)

Table B-5 Environmental and Power Specifications for the 10-Gbps SFP+ Optical Transceivers

Parameter ¹	Specification
Storage temperature	−40 to 185°F (−40 to 85°C)
Case temperature ²	32 to 158°F (0 to 70°C)
Relative humidity	5 to 95%
Module supply voltage	3.1 to 3.5 V

1. Absolute maximum ratings are those values beyond which damage to the device may occur if these limits are exceeded for other than a short period of time.
2. Functional performance is not intended, device reliability is not implied, and damage to the device may occur over an extended period of time between absolute maximum ratings and the recommended operating conditions.

SFP+ Copper Transceiver Specifications

This section provides the general and environmental specifications for the SFP+ transceivers used with copper cables.

For the cable specifications that apply to SFP+ copper transceivers, see [Table B-6](#).

Table B-6 Cable Specifications for the 10-Gbps SFP+ Copper Transceivers

Transceiver	Cable Length
SFP-H10GB-CU7M	23.0 feet (7 meters)
SFP-H10GB-CU10M	32.8 feet (10 meters)

Airflow Optimization Accessories

This section describes the airflow optimization accessories for the Cisco Nexus FEX.

For the details of the Cisco Nexus airflow extension sleeve and the Cisco Nexus airflow vent, see [Table B-7](#).

Table B-7 Airflow Optimization Accessories

Accessories	Airflow Extension Sleeve	Airflow Vent
PID	NXA-AIRFLOW-SLV (2200 Series) NXA-AIRFLOW-SLV-E (2300 Series)	NXA-ACC-KIT-BAV
Name	Cisco Nexus Airflow Extension Sleeve	Cisco Nexus Airflow Vent
Description	Optimizes airflow in port side exhaust airflow deployments (port side exhaust) for alignment of port in back of rack and extension of power supply side of chassis to port side exhaust of rack with airflow sleeve	Optimizes airflow in port side intake top of rack deployments (port side intake). Airflow vent consists of metallic cover to place on the upper exhaust of the FEX port side and mounting rails with snap on holes for airflow vent.
Dimensions (height x width x depth)	1.72" (1RU) x 17.3" x 8.5"(fully retracted)* or 12.9"(fully extended)* *Adjustable depth for the FEX, between 26 and 30 inches	Vent cover is part of the mounting hardware kit and its size is meaningless to overall form factor of the chassis: 0.42" x 17.53" x 2.56"
Weight	5.7 lbs or 2.6 kg	0.42 lbs or 0.19 kg



Cable and Port Specifications

This appendix provides cable and port specifications for the Fabric Extender (FEX) and includes the following sections:

- [Supported Power Cords and Plugs, page C-1](#)
- [Jumper Power Cord, page C-8](#)

Supported Power Cords and Plugs

Each power supply has a separate power cord. Standard power cords or jumper power cords are available for connection to a power distribution unit that has IEC 60320 C19 outlet receptacles. The jumper power cords, for use in cabinets, are available as an optional alternative to the standard power cords.

Power Cords

The standard power cords have an IEC C19 connector on the end that plugs into the device. The optional jumper power cords have an IEC C19 connector on the end that plugs into the device and an IEC C20 connector on the end that plugs into an IEC C19 outlet receptacle.



Note

Only the regular power cords or jumper power cords provided with the device are supported.

[Table C-1](#) lists the AC power cords for the Cisco Nexus Fabric Extender and provides their lengths in feet and meters.

Table C-1 AC Power Cords for the Cisco Nexus Fabric Extender

Description	Length		Power Cord Reference Illustration
	Feet	Meters	
SFS-250V-10A-AR Power Cord, 250 VAC 10 A IRAM 2073 Plug Argentina	8.2	2.5	Figure C-1
CAB-9K10A-AU 250 VAC 10 A 3112 Plug, Australia	8.2	2.5	Figure C-2

Table C-1 AC Power Cords for the Cisco Nexus Fabric Extender (continued)

Description	Length		Power Cord Reference Illustration
	Feet	Meters	
SFS-250V-10A-CN Power Cord, 250 VAC 10 A GB 2009 Plug China	8.2	2.5	Figure C-3
CAB-9K10A-EU Power Cord, 250 VAC 10 A M 2511 Plug Europe	8.2	2.5	Figure C-4
SFS-250V-10A-ID Power Cord, 250 VAC 16A EL-208 Plug South Africa, United Arab Emirates, India	8.2	2.5	Figure C-5
SFS-250V-10A-IS Power Cord, 250 VAC 10 A SI32 Plug Israel	8.2	2.5	Figure C-6
CAB-9K10A-IT Power Cord, 250 VAC 10 A CEI 23-16 Plug Italy	8.2	2.5	Figure C-7
CAB-9K10A-SW Power Cord, 250 VAC 10 A MP232 Plug Switzerland	8.2	2.5	Figure C-8
CAB-9K10A-UK Power Cord, 250 VAC 10 A BS1363 Plug (13 A fuse) United Kingdom	8.2	2.5	Figure C-9
CAB-AC-250V/13A Power Cord, 250 VAC 13 A IEC60320 Plug North America	6.6	2.0	Figure C-10
CAB-N5K6A-NA Power Cord, 250 VAC 13 A NEMA 6-15 Plug, North America	8.2	2.5	Figure C-11
CAB-9K12A-NA Power Cord, 125VAC 15A NEMA 5-15 Plug, North America	8.2	2.5	Figure C-12
CAB-C13-CBN Cabinet Jumper Power Cord, 250 VAC 16A, C14-C13 Connectors	2.25	0.686	Figure C-13
CAB-IND-10A(=) 10A Power cable for India	8.2	2.5	Figure C-14
CAB-C13-CBN Cabinet Jumper Power Cord, 250 VAC 16A, C14-C13 Connector	2.25	0.686	Figure C-15
CAB-C13-C14-JMPR Cabinet Jumper Power Cord, 250 VAC 13 A, C14-C15 Connector	2.2	0.7	Figure C-16

Table C-1 AC Power Cords for the Cisco Nexus Fabric Extender (continued)

Description	Length		Power Cord Reference Illustration
	Feet	Meters	
CAB-C13-C14-2M(=) Power Cord Jumper, C13-C14 Connectors, 2 Meter Length	6.6	2.0	
CAB-C13-C14-AC(=) Power Cord Jumper, C13-C14 Connectors, 3 Meter Length		3.0	

Figure C-1 SFS-250V-10A-AR

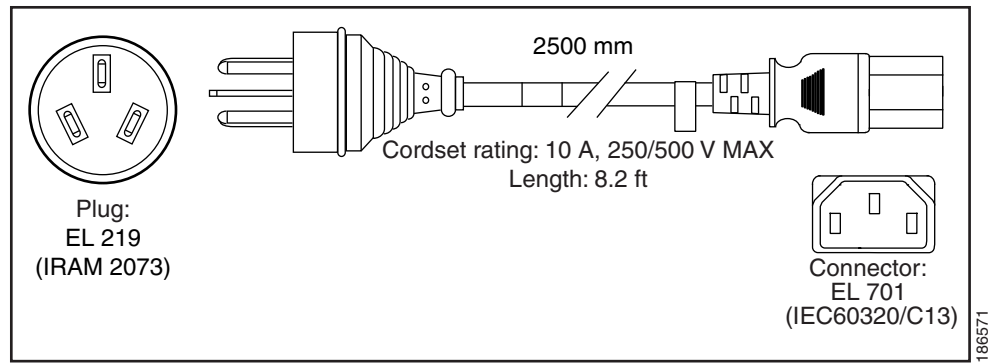

Figure C-2 CAB-9K10A-AU

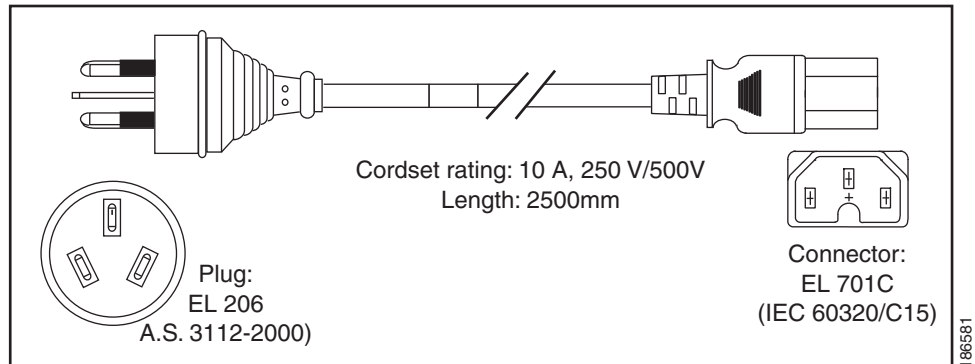
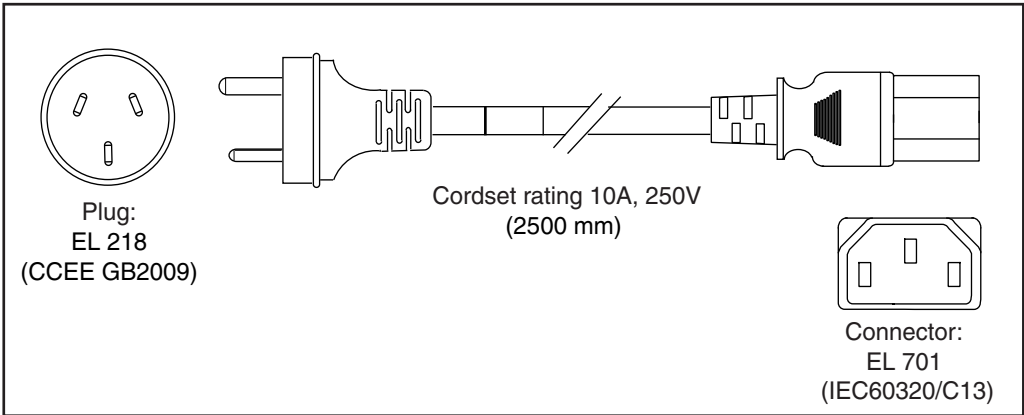
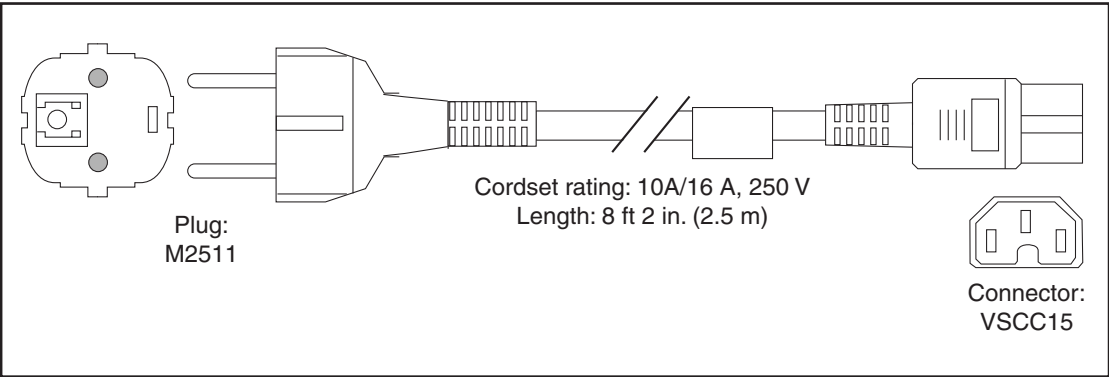

Figure C-3 SFS-250V-10A-CN



186573

Figure C-4 CAB-9K10A-EU



186576

Figure C-5 SFS-250V-10A-ID

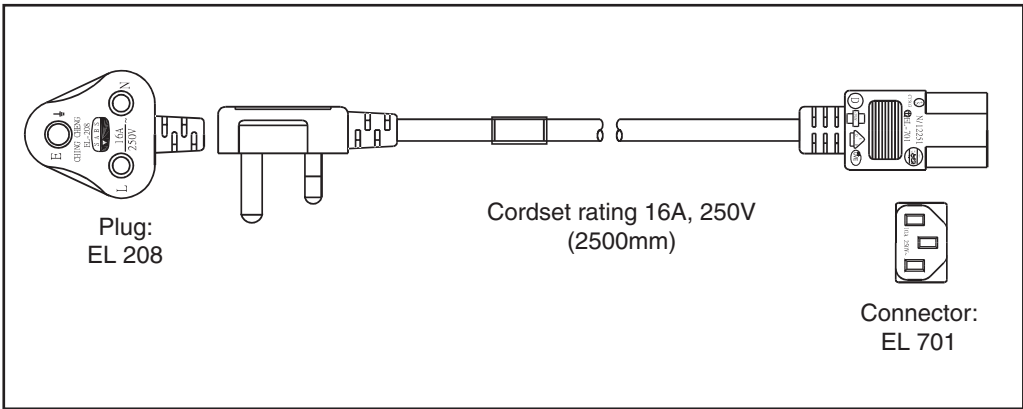

187490

Figure C-6 SFS-250V-10A-IS

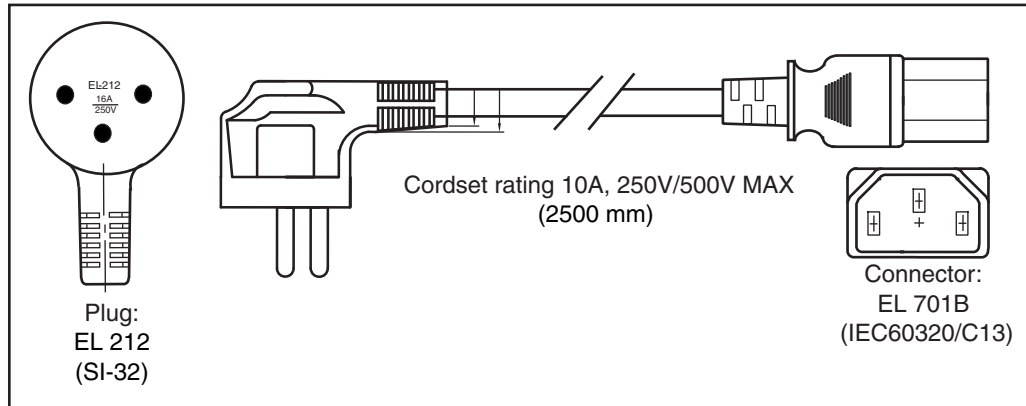

186574

Figure C-7 CAB-9K10A-IT

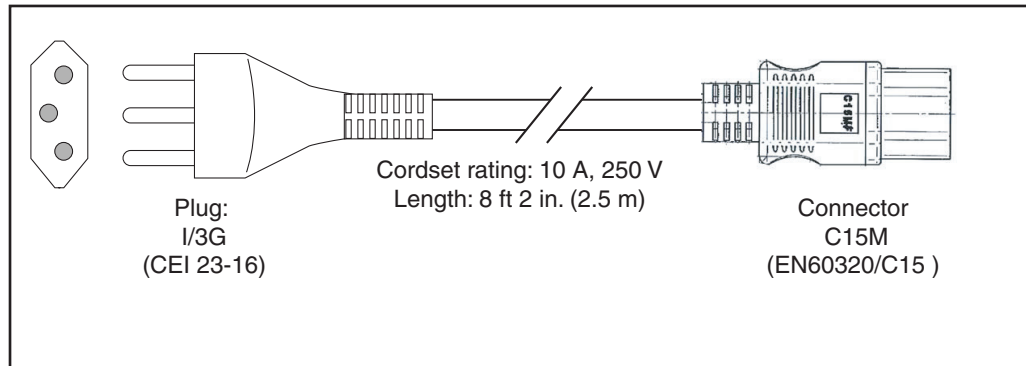

186575

Figure C-8 CAB-9K10A-SW

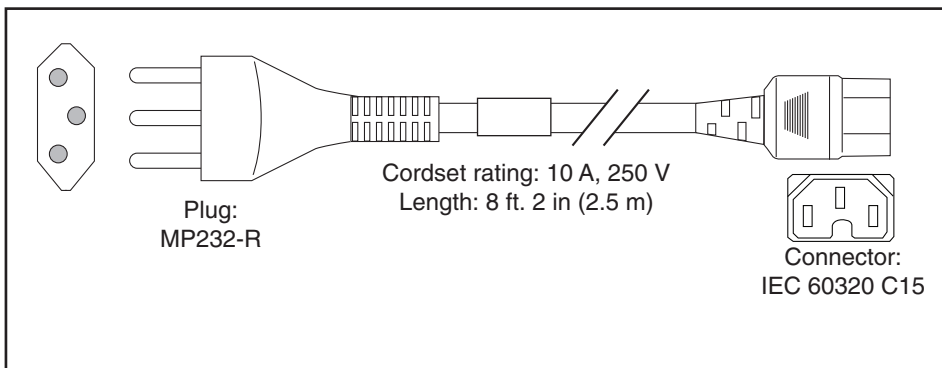

186576

Figure C-9 CAB-9K10A-UK

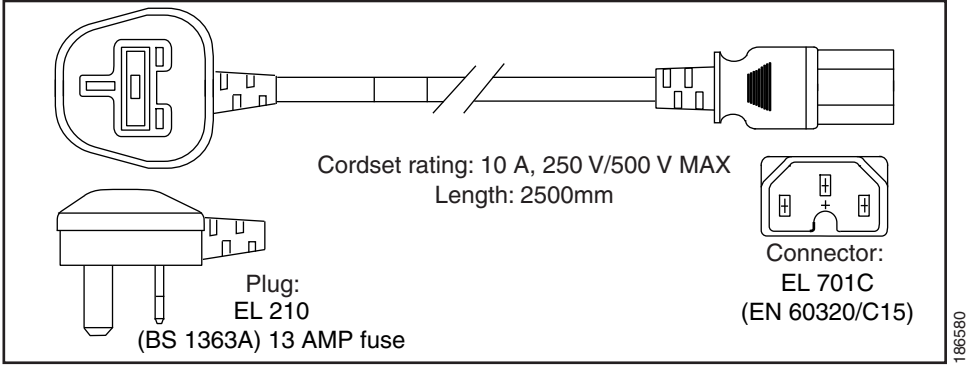

Figure C-10 CAB-AC-250V/13A

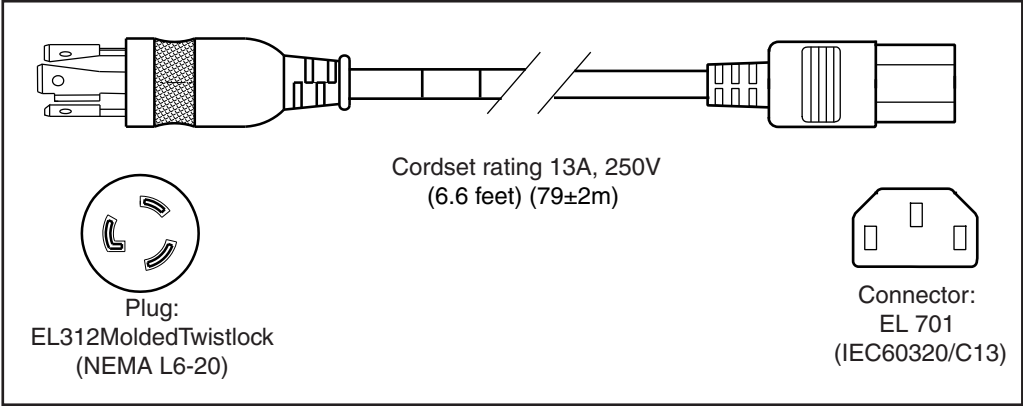

Figure C-11 CAB-N5K6A-NA

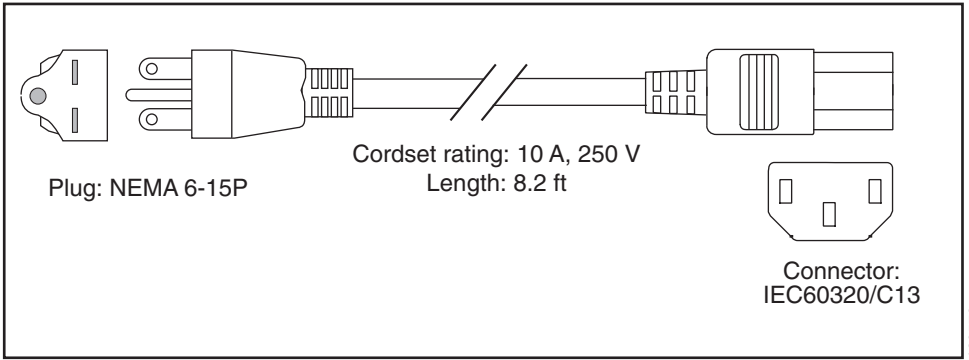

Figure C-12 CAB-9K12A-NA

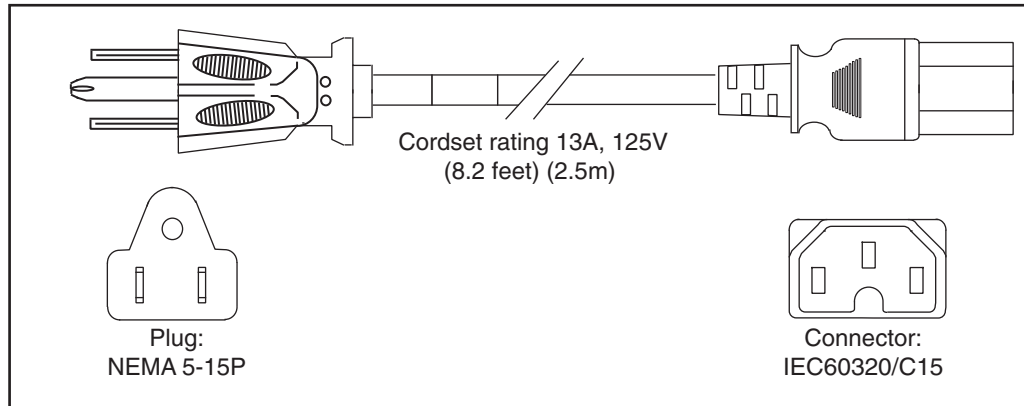

Figure C-13 CAB-C13-CBN

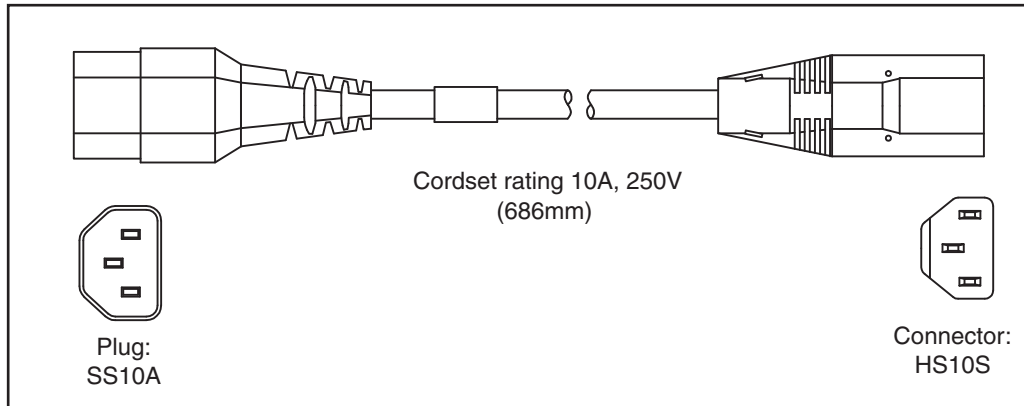

Figure C-14 CAB-IND-10A

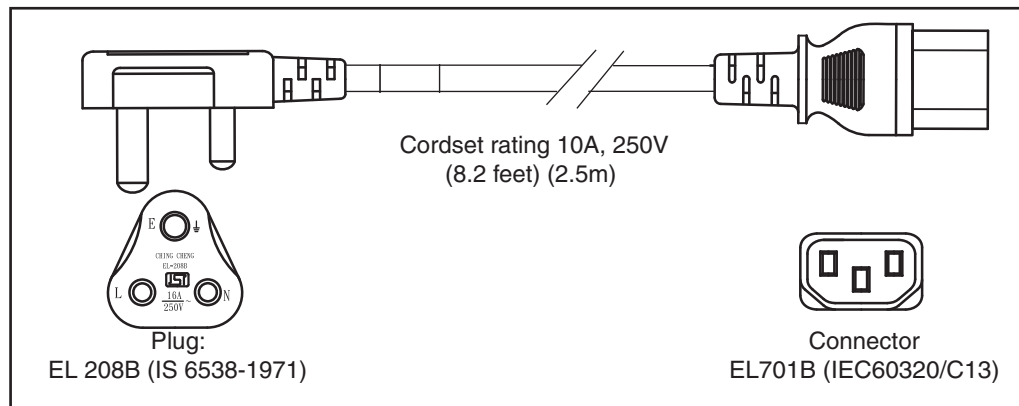

Figure C-15 CAB-C13-CBN

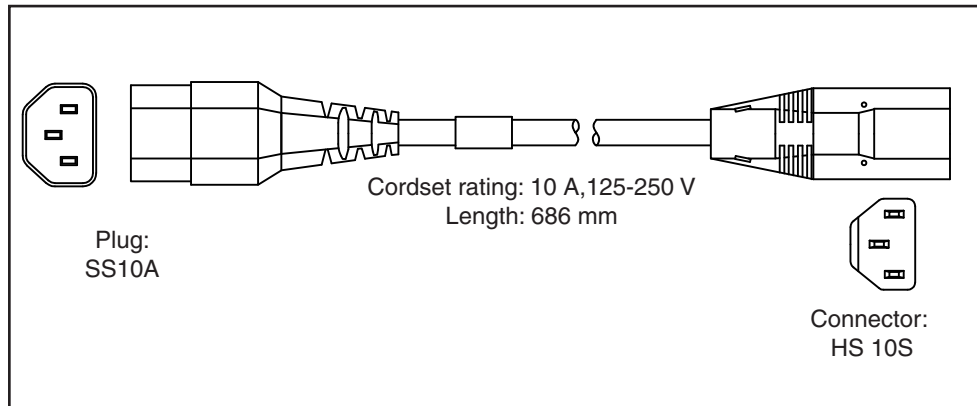

Table C-2 lists the AC power cords for the Cisco Nexus 2232TM.

Table C-2 AC Power Cords for the Cisco Nexus 2232TM

Power Cords	Description
CAB-3KX-AC=	AC power card for North America
CAB-3KX-AC-AP=	AC power card for Australia
CAB-3KX-AC-AR=	AC power card for Argentina
CAB-3KX-AC-SW=	AC power card for Switzerland
CAB-3KX-AC-UK=	AC power card for United Kingdom
CAB-3KX-AC-JP=	AC power card for Japan
CAB-3KX-AC-EU=	AC power card for Europe
CAB-3KX-AC-IT=	AC power card for Italy
CAB-3KX-AC-IN=	AC power card for India
CAB-3KX-AC-CN=	AC power card for China
CAB-3KX-AC-DN=	AC power card for Denmark
CAB-3KX-AC-IS=	AC power card for Israel

Jumper Power Cord

Figure C-16 shows the plug connector on the optional jumper power cord for the Cisco Nexus Fabric Extender. The plug plugs into the Cisco Nexus Fabric Extender power supply, while the connector plugs into the receptacle of a power distribution unit for a cabinet.

Figure C-16 CAB-C13-C14-JMPR, Jumper Power Cord

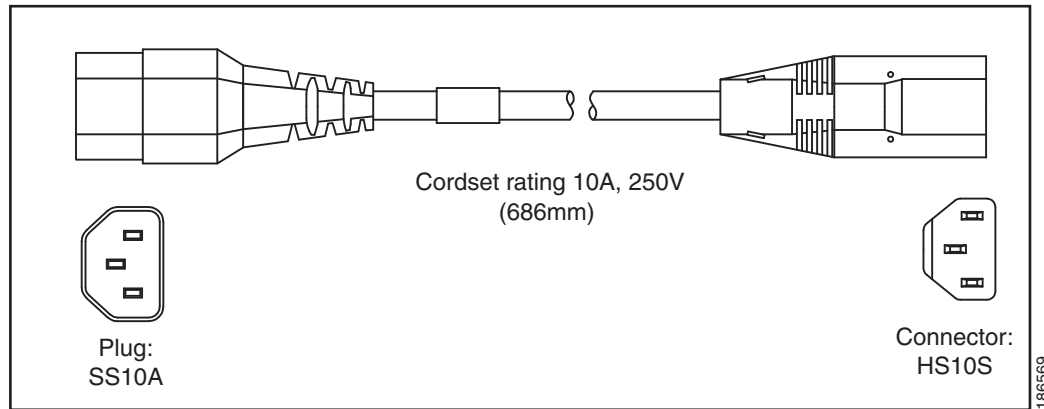



Troubleshooting Hardware Components

This chapter describes how to identify and resolve problems that might occur with the hardware components of the Cisco Nexus 2000 Series Fabric Extender (FEX) or Cisco Nexus 2300 Series FEX. It includes the following sections:

- [Overview, page D-1](#)
- [SNMP Traps, page D-1](#)
- [Device Hardware Guidelines, page D-2](#)
- [Contacting Customer Service, page D-3](#)

Overview

The key to success when troubleshooting the system hardware is to isolate the problem to a specific system component. The first step is to compare what the system is doing to what it should be doing. Because a startup problem can usually be attributed to a single component, it is more efficient to isolate the problem to a subsystem rather than troubleshoot each separate component in the system.

Problems with the initial power up are often caused by a module that is not firmly connected to the backplane or a power supply that has been disconnected from the power cord connector.

Overheating can also cause problems with the system, though typically only after the system has been operating for an extended period of time. The most common cause of overheating is the failure of a fan tray.

SNMP Traps

You can set SNMP traps to monitor fans, power supplies, and temperature settings, or to test a call home application. Use the following commands to set SNMP traps:

- **test pfmtest-SNMP-trap fan**
- **test pfmtest-SNMP-trap power supply**
- **test pfmtest-SNMP-trap temp-sensor**

Device Hardware Guidelines

Use the recommendations in this section to ensure the proper installation, initialization, and operation of the device. This section includes the following topics:

- [Installation, page D-2](#)
- [Initialization, page D-2](#)
- [Device Operation, page D-2](#)

Installation

When installing the device, follow these best practices:

- Plan your site configuration and prepare the site before installing the chassis.
- Verify that you have the appropriate power supplies and fan trays for your chassis configuration. For each chassis, each module must have the same airflow direction. Either all modules have front-to-back airflow (no black stripe on the front) or all have back-to-front airflow (black stripe on the front). If you have modules that use different airflow directions in the same chassis, you will see an error message.
- Install the chassis following the rack and airflow guidelines in this publication.
- Verify that the chassis and DC power supplies are adequately grounded.

Initialization

When the initial system boot is complete, verify the following:

- Power supplies are supplying power to the system.
- Fan trays are operating normally.
- The system software boots successfully. See the *Cisco Nexus 2000 Series Fabric Extender Software Configuration Guide* for information about booting the system and initial configuration task.

Device Operation

To ensure proper operation of your device, do the following:

- Make a copy of the running configuration to CompactFlash for a safe backup.
- Always enter the **copy running-config startup-config** command after you modify the running configuration and ensure that the system is operating properly.
- Never use the **init system** command unless you understand that you will lose the running and startup configuration as well as the files stored on bootflash:.
- Keep backup copies of the running kickstart and the system images on CompactFlash.

Contacting Customer Service

If you are unable to solve a startup problem after using the troubleshooting suggestions in this chapter, contact a customer service representative for assistance and additional instructions. Before you call, have the following information ready to help your service provider assist you as quickly as possible:

- Date that you received the device
- Chassis serial number (located on a label on the right of the rear panel of the chassis)
- Type of software and release number
- Maintenance agreement or warranty information
- Brief description of the problem
- Brief explanation of the steps that you have already taken to isolate and resolve the problem

To contact Cisco Technical Support, go to:

<http://www.cisco.com/c/en/us/support/web/tsd-cisco-worldwide-contacts.html>.



LEDs

This appendix describes the conditions indicated by the chassis and module LEDs on the Cisco Nexus Fabric Extenders (FEXs).

This appendix includes the following sections:

- [Chassis and Module LEDs for the Cisco Nexus Fabric Extenders, page E-1](#)
- [Port LEDs, page E-4](#)

Chassis and Module LEDs for the Cisco Nexus Fabric Extenders

This section includes the following topics:

- [Chassis and Module LED Descriptions, page E-2](#)
- [Power Supply Status, page E-3](#)

Chassis and Module LED Descriptions

Table E-1 describes the chassis LEDs for the Cisco Nexus Fabric Extenders.

Table E-1 LEDs for the Cisco Nexus Fabric Extenders

Component	LED	Status	Description
Chassis (port side exhaust and back)	ID	On (blue)	Identifies the chassis receiving the beacon signal.
	Status	Solid on (green)	All diagnostics pass. The module is operational.
		Off	The module is not receiving power.
		On (amber)	The module is booting or running diagnostics. An overtemperature condition has occurred. The temperature threshold has been exceeded by a small value during environmental monitoring.
		Blinking (amber)	An overtemperature condition has occurred. The temperature threshold has been exceeded by a large value during environmental monitoring. If the module fails during initial reset, the LED continues to blink and the module does not come online. The module has a runtime failure and is brought offline.
Fan and fan tray (port side exhaust of chassis)	Status	Solid on (green)	All diagnostics pass. The module is operational.
		Off	The module is not receiving power.
		Solid on (amber)	The module is booting or running diagnostics.
		Blinking (amber)	If the module fails during initial reset, the LED continues to blink and the module does not come online. The module has a runtime failure and is brought offline.
Power supply (port side exhaust of chassis)	OK (green)	Solid on	Power supply is on and okay.
		Blinking	12 voltage standby (VSB) is on but the power supply unit is not powering the other modules.
		Off	No AC power to the power supply.
	FAULT (amber)	Solid on	Power supply failures, overvoltage, overcurrent, or overtemperature has occurred.
		Blinking	AC is present, 12 VSB on, and the power supply is off.
		Off	Operating normally.

Table E-1 LEDs for the Cisco Nexus Fabric Extenders

Component	LED	Status	Description
Port LED	Indicates LED status	Off	The port is not active or the link is not connected.
		Solid on (green)	The port is active. The link is connected and operational.
		Solid on (amber)	The module or port is disabled through the CLI command or the module is initializing.
		Blinking (amber)	The port is faulty and has been disabled.

For a description of the two power supply status, see the “Power Supply Status” section on page E-3.

Power Supply Status

This section describes the power supply LED indicators for the Cisco Nexus Fabric Extenders. [Table E-2](#) describes the status indicated by the Cisco Nexus 2348TQ, Cisco Nexus 2348UPQ, Cisco Nexus 2248TP-ETP, 2232PP, and 2224TP power supply LEDs. [Table E-3](#) describes the status indicated by the Cisco Nexus 2148T power supply LEDs.

Table E-2 Power Supply LED Indicators for the Cisco Nexus 2348TQ, Cisco Nexus 2348UPQ, Cisco Nexus 2248TP-ETP, 2232PP, and 2224TP

Condition	OK LED Status (Green)	FAIL LED Status (Amber)
No AC power to the power supplies	Off	Off
Power supply failure (includes overvoltage, overcurrent, overtemperature, and fan failure)	Off	On
Power supply warning events where the power supply continues to operate (high temperature, high power, and slow fan)	Off	1 blinking
AC present /voltage standby (VSB) on, and power supply unit off	blinking	Off
Power supply On and OK	On	Off

Table E-3 Power Supply LED Indicators for the Cisco Nexus 2148T

Condition	INPUT OK LED Status (Green)	OUTPUT OK LED Status (Red)
No AC power to the power supplies	Off	Off
Power supply failure (includes overvoltage, overcurrent, overtemperature, and fan failure)	Off	On

Table E-3 Power Supply LED Indicators for the Cisco Nexus 2148T (continued)

Condition	INPUT OK LED Status (Green)	OUTPUT OK LED Status (Red)
Power supply warning events where the power supply continues to operate (high temperature, high power, and slow fan)	Off	Blinking
AC present and power supply unit off	Blinking	Off
Power supply On and OK	On	Off

Port LEDs

This section includes the following topics:

- [Ethernet Port LEDs, page E-4](#)
- [Ethernet and Fibre Channel LEDs, page E-4](#)

Ethernet Port LEDs

[Table E-4](#) lists the LED descriptions for the RJ-45 Ethernet port LEDs.

Table E-4 Ethernet Port LED Descriptions

LED	Status	Description
Left	Off	No link
	Solid green	Physical link
Right	Off	No activity
	Blinking green	Activity

Ethernet and Fibre Channel LEDs

There are 20 to 26 port activity LEDs on the FEX depending on whether the module is a Fibre Channel or 10-Gigabit Ethernet module. [Table E-5](#) describes the behavior of the port LEDs.

Table E-5 Port-Level LEDs

Link State	LED State	Notes
Link Down	OFF	—
POST failed on port	AMBER blinking yellow	—

Table E-5 *Port-Level LEDs*

Link State	LED State	Notes
Administrative disabled	AMBER_ON	Depending on the product you look at, the LED could be off, or solid amber
Link Up, port in STP forwarding state	GREEN_ON	Blinks based on network activity



Accessory Kit

This appendix lists the accessory kit contents for the Cisco Nexus Fabric Extenders (FEXs). This appendix includes the following sections:

- [Accessory Kit for Cisco Nexus 2300 Series FEXs, page F-7](#)
- [Accessory Kit for Cisco Nexus 2248TP-E, 2224TP, 2232PP, 2248TP, 2232TM, and 2148T, page F-8](#)

Accessory Kit for Cisco Nexus 2300 Series FEXs

Accessory kits for the Cisco Nexus 2300 Series FEXs contain the following items:

- 2 slider rails
- 1 rack-mount guide
- 1 rack-mount bracket
- 10 M4 x 0.7 x 7-mm Phillips countersunk screws
- 1 ground lug kit
- 1 ESD wrist strap

[Table F-2](#) provides ordering information for the Cisco Nexus 2300 Series FEXs.

Table F-1 *Accessory Kit Information for the Cisco Nexus 2300 Series Fabric Extenders*

Accessory Kit	Details
N2300-ACC-KIT	Cisco Nexus 2300 FEX accessory kit
N2300-ACC-KIT=	Cisco Nexus 2300 FEX accessory kit, spare



Note

Additional parts can be ordered from your customer service representative.

Accessory Kit for Cisco Nexus 2248TP-E, 2224TP, 2232PP, 2248TP, 2232TM, and 2148T

Accessory kits for the Cisco Nexus 2148T, 2224TP, 2232PP, 2248TP, 2248TP-E, and 2232TM FEXs contain the following items:

- 2 slider rails
- 2 rack-mount guides
- 2 rack-mount brackets
- 16 M4 x 0.7 x 8-mm Phillips countersunk screws
- 1 ground lug kit
- 1 ESD wrist strap

[Table F-2](#) provides ordering information for the Cisco Nexus 2148T, 2224TP, 2232PP, 2248TP-ETP, and 2232TM FEXs.

Table F-2 *Accessory Kit Information for the Cisco Nexus 2148T, 2224TP, 2232PP, 2248TP, 2248TP-E, and 2232TM Fabric Extenders*

Accessory Kit	Details
N2K-C2148T-ACC	Cisco Nexus 2000 FEX 1GE accessory kit, spare
N2200-ACC-KIT	Cisco Nexus 2200 FEX accessory kit, spare



Note

Additional parts can be ordered from your customer service representative.



Site Preparation and Maintenance Records

This appendix includes the following records to use when installing the Cisco Nexus Fabric Extender (FEX):

- [Site Preparation Checklist, page G-1](#)
- [Contact and Site Information, page G-3](#)
- [Chassis and Module Information, page G-3](#)



Note

For information about how to query the device for configuration information, see the *Cisco Nexus 2000 Switch Configuration Guide*.

Site Preparation Checklist

Planning the location and layout of your equipment rack or wiring closet is essential for successful device operation, ventilation, and accessibility. [Table G-1](#) lists the site planning tasks that we recommend completing before installing the Cisco Nexus FEX.

Consider heat dissipation when sizing the air-conditioning requirements for an installation. See [Table B-2 on page B-6](#) for the environmental requirements and the “[Power Specifications](#)” section on [page B-1](#) for power and heat ratings.

Table G-1 Site Planning Checklist

Task No.	Planning Activity	Verified By	Time	Date
1	Space evaluation: <ul style="list-style-type: none"> • Space and layout • Floor covering • Impact and vibration • Lighting • Maintenance access 			
2	Environmental evaluation: <ul style="list-style-type: none"> • Ambient temperature • Humidity • Altitude • Atmospheric contamination • Air flow 			
3	Power evaluation: <ul style="list-style-type: none"> • Input power type • Power receptacles¹ • Receptacle proximity to the equipment • Dedicated circuit for power supply • Dedicated (separate) circuits for redundant power supplies • UPS² for power failures 			
4	Grounding evaluation: <ul style="list-style-type: none"> • Circuit breaker size • CO ground (AC-powered systems) 			
5	Cable and interface equipment evaluation: <ul style="list-style-type: none"> • Cable type • Connector type • Cable distance limitations • Interface equipment (transceivers) 			
6	EMI ³ evaluation: <ul style="list-style-type: none"> • Distance limitations for signaling • Site wiring • RFI⁴ levels 			

1. Verify that the power supply installed in the chassis has a dedicated AC source circuit.

2. UPS = uninterruptible power supply.

3. EMI = electromagnetic interference.
4. RFI = radio frequency interference.

Contact and Site Information

Use the following worksheet (see [Table G-2](#)) to record contact and site information.

Table G-2 **Contact and Site Information**

Contact person	
Contact phone	
Contact e-mail	
Building/site name	
Data center location	
Floor location	
Address (line 1)	
Address (line 2)	
City	
State	
Zip code	
Country	

Chassis and Module Information

Use the following worksheet (see [Table G-3](#)) to record information about the chassis.

Contract Number _____

Chassis Serial Number _____

Product Number _____

Table G-3 Network-Related Information

Device IP address	
Device IP netmask	
Host Name	
Domain name	
IP broadcast address	
Gateway/router address	
DNS address	
Modem telephone number	