

SILVERADO 2500HD CREW CAB 4WD WORK TRUCK - 1WT¹



UPDATES FOR 2011

New Features

- (LML) Duramax 6.6L turbo diesel V8, B20-Diesel compatible engine
- (LGH) Duramax 6.6L turbo diesel V8, B20-Diesel compatible engine (requires ZW9 pickup box delete)
- Exterior color (GGU) Steel Green Metallic
- (ASF) Head curtain side-impact air bags¹, front outboard seating positions with rollover sensor
- (AJ7) Seat-mounted side-impact air bags¹, driver and right-front passenger for thorax and pelvic protection
- (PYN) 17" (43.2 cm) steel wheels
- (PYP) 17" (43.2 cm) chrome-clad steel wheels
- (PYT) 18" (45.7 cm) painted steel wheels
- (QHJ) LT245/75R17 all-season, blackwall tires
- (QGM) LT265/70R18E all-terrain tires
- (QWF) LT265/70R18E all-season tires
- (K40) Exhaust Brake
- (GEH) 9500 lbs. (4309 kg) GVWR⁵
- (C4M) 9900 lbs. (4490 kg) GVWR⁵
- (C7A) 10,000 lbs. (4536 kg) GVWR⁵

Changes

- New grille hood and front bumper appearance
- (JL4) StabiliTrak, stability control system is now standard on all models and includes electronic trailer sway control, intelligent brake assist and hill start assist
- (VYU) Snow Plow Prep Package now available on all 4WD engine and cab combinations
- New chassis and suspension
- Short and long box fuel tanks increased to 36 gallons

Deletions

- (LY6) Vortec 6.0L variable valve timing V8 SFI engine
- (LMM) Duramax 6.6L turbo diesel V8, B5-diesel compatible engine
- (QB5) 16" x 6.5" (40.6 cm x 16.5 cm) 8-lug painted steel wheels
- (PY2) 4- 16" x 6.5" (40.6 cm x 16.5 cm) 8-lug chrome-styled steel wheels
- (C6W) 9200 lbs. (4173 kg) GVWR⁵
- (PY0) 4- 16" x 6.5" (40.6 cm x 16.5 cm) 8-lug polished forged aluminum wheels
- (QIZ) LT 245/75R16E all-season, blackwall tires
- (QIW) LT245/75R16E on/off-road, blackwall tires
- Exterior color (58U) Black Granite Metallic
- (VBJ) LPO, Underseat storage, composite storage bin under the rear seat

1. Head curtain side air bags are designed to help reduce the risk of head and neck injuries to front and rear seat occupants on the near side of certain side-impact collisions.

Always use safety belts and the correct child restraints for your child's age and size, even in vehicles equipped with air bags. Children are safer when properly secured in a rear seat. See your vehicle Owner's Manual and child safety seat instructions for more information.

5. Gross Vehicle Weight Rating (GVWR). When properly equipped, includes vehicle, passengers, cargo and equipment.

2 | SILVERADO 2500HD CREW CAB 4WD WORK TRUCK - 1WT

Note: This vehicle is NOT designed nor intended for use IN HIGH SPEED EMERGENCY VEHICLE OPERATIONS

MODEL AVAILABILITY

CK20743	4-wheel drive 3/4 ton fleetside standard bed crew cab pickup
CK20943	4-wheel drive 3/4 ton fleetside long bed crew cab pickup

STANDARD EQUIPMENT SUMMARY

WARRANTY	3 years / 36,000 miles bumper-to-bumper (whichever comes first, see dealer for details) 5 years / 100,000 miles limited powertrain (whichever comes first, see dealer for details)
----------	---------------------------------------------------------------------------------------------------------------------------------------------------------------------------------------

INTERIOR FEATURES

AIR CONDITIONING	Single-zone manual front climate control
ASSIST HANDLES	Front passenger, rear assist handles in the headliner
AUDIO SYSTEM FEATURE	Speaker system (includes 6 speakers)
COAT HOOKS	Rear driver and passenger side
CUP HOLDERS	Front, rear
DOME LAMPS	Interior with dome and reading lamps, illuminated entry feature and backlit instrument panel switches
DOOR LOCKS	Power includes AU0 remote keyless entry unless SE0 5B5 power windows, locks and mirrors is ordered
DRIVER INFORMATION CENTER	Odometer, trip odometer and message center (monitors numerous systems depending on vehicle equipment level including low fuel, turn signal on, transmission temperature and oil change notification) (Driver Information Center controls are operated through the trip button unless UK3 steering wheel mounted audio controls is ordered)
FLOOR COVERING	Black rubberized-vinyl
MIRROR	Inside rearview manual day/night
POWER OUTLETS	2 auxiliary instrument panel-mounted with covers, 12-volt
RADIO	AM/FM stereo with seek-and-scan and digital clock with 4-speaker system
RESTRAINT SYSTEM	Frontal, driver and right-front passenger seat mounted side-impact air bags ¹ , driver and right-front passenger for thorax and pelvic protection, head curtain side-impact front outboard seating positions with rollover sensor; always use safety belts and the correct child restraints for your child's age and size, even in vehicles equipped with air bags ¹ ; children are safer when properly secured in a rear seat (see the vehicle's owner's manual and child safety seat instructions for more safety information)
SEAT TRIM	Dark Titanium vinyl (vinyl seats require BG9 Graphite-colored rubberized-vinyl floor covering)
SEAT, FRONT	40/20/40 split-bench, 3-passenger, driver and front passenger manual reclining with outboard head restraints and center fold-down armrest with storage
SEAT, REAR	60/40 folding bench (folds up), 3-passenger, folding (includes child seat top tether anchor)
SPEEDOMETER/CLUSTER	Analog with speedometer, fuel level, engine temperature, tachometer, volt meter and oil pressure indicators
STEERING WHEEL	Includes theft deterrent locking feature
STEERING COLUMN	Tilt-wheel, adjustable with brake/transmission shift interlock
THEFT DETERRENT	Vehicle theft PASS-Key [®] III
VISORS	Driver and front passenger, sliding with clip and passenger side vanity mirror with cover, Opal Gray-colored
WARNING TONES	Headlamp on, key-in-ignition, driver and passenger buckle up reminder and turn signal on

1. Head curtain side air bags are designed to help reduce the risk of head and neck injuries to front and rear seat occupants on the near side of certain side-impact collisions. Always use safety belts and the correct child restraints for your child's age and size, even in vehicles equipped with air bags. Children are safer when properly secured in a rear seat. See your vehicle Owner's Manual and child safety seat instructions for more information.

EXTERIOR FEATURES

AIR DAM	Black
BUMPER, FRONT	Chrome
BUMPER, REAR	Chrome, step-style with pad
DAYTIME RUNNING LAMPS	Automatic exterior lamp control
DOOR HANDLES	Black
GLASS	Solar-Ray light-tinted, all windows
GRILLE	Chrome surround
HEADLAMPS	Dual halogen composite with automatic exterior lamp control and flash-to-pass feature
KEYLESS ENTRY	2 transmitters, panic button and content theft alarm (included and only available with AU3 power door locks; if SE0 5B5 power windows, locks and mirrors is ordered AU0 becomes optional on all models)
LAMPS	Dual cargo area lamps
MIRRORS	Outside manual Black, manual-folding
PAINT	Solid
PICKUP BODY	Fleetside
WINDOWS	Fixed rear access door
WINDSHIELD WIPERS	Front intermittent wet-arm with pulse washers

CHASSIS FEATURES

AIR CLEANER	High-capacity
ALTERNATOR	125-amps
BATTERY	Heavy-duty 600 cca, maintenance-free with rundown protection and retained accessory power
BRAKES	4-wheel antilock, 4-wheel disc
COOLING, ENGINE	External engine oil cooler, heavy-duty air-to-oil, integral to driver side of radiator tank
COOLING, TRANSMISSION	Auxiliary external transmission oil cooler, heavy-duty air-to-oil
DRIVE	4-wheel drive
ENGINE	Vortec 6.0L variable valve timing V8 SFI
EXHAUST	Aluminized stainless-steel muffler and tailpipe
FRAME	Hydroformed
FUEL TANK	36 gallon (136 liter)
PICKUP BOX	Fleetside
REAR AXLE	3.73 ratio
RECOVERY HOOKS	Front, frame-mounted
STABILITRAK	Stability control system, includes electronic trailer sway control, intelligent brake assist and hill start assist
STEERING	Power, recirculating ball
SUSPENSION, FRONT	Independent, torsion bar with increased front GAWR, includes 35mm twin tube shock absorbers and 36mm front stabilizer bar
SUSPENSION, REAR	4 + 1 multi-leaf springs
SUSPENSION PACKAGE	Handling/trailer, heavy-duty includes 46 mm piston monotube shocks and 34 mm front stabilizer bar
TIRE PRESSURE MONITOR	CHECK TIRE PRESSURE will show on Driver Information Center (does not apply to spare tire)
TIRE, SPARE CARRIER	Outside, winch-type mounted under frame at rear (orders with ZW9 pickup box delete will not include a spare tire carrier unless a spare tire is ordered)
TIRES	LT245/75R17 all-season blackwall (includes full-size spare)
TRANSFER CASE	Floor-mounted shifter (requires 4-wheel drive models)
TRANSMISSION	6-speed automatic, heavy-duty, electronically controlled with overdrive and tow/haul mode (requires L96 Vortec 6.0L V8 SFI engine)
WHEELS	17" (43.2 cm) steel, includes N24 17" x 7.5" (43.2 cm x 19.1 cm) steel spare wheel. Spare not included with ZW9 pickup box delete unless a spare tire is ordered

POWERTRAIN						
<i>S = Standard</i> <i>A = Available</i>		TRANSMISSION		AXLE		GVWR lbs (kg)
ENGINE	MYD	MW7 Allison 1000	GT4	GT5		
	6-speed auto.	6-speed auto. with OD	3.73	4.10		
STANDARD						
CK20743	L96 Vortec 6.0L variable valve timing V8 SFI	S	—	S	A	GEH 9,500 (4,309)
CK20943	L96 Vortec 6.0L variable valve timing V8 SFI	S	—	S	A	CHM 9,900 (4,490)
OPTIONAL						
LML/LGH	Duramax 6.6L turbo diesel V8, B20-diesel compatible (requires MW7 Allison 1000 6-speed automatic transmission; includes TUV heavy-duty dual, 730 cca battery and K05 engine block heater)	—	S	S	—	C7A 10,000 (4,536)

EMISSIONS - MUST BE SPECIFIED	
FE9	FEDERAL EMISSIONS. Use for ordering vehicles that will be registered in all states except California, Connecticut, Maine, Maryland, Massachusetts, New Jersey, New Mexico, New York, Oregon, Pennsylvania, Rhode Island, Vermont and Washington State
YF5	CALIFORNIA EMISSIONS. Use for ordering vehicles that will be registered in California.
NE1	CT/ME/MD/MA/NJ/NM/NY/OR/PA/RI/VT/WA EMISSIONS. Use for ordering vehicles that will be registered in Connecticut, Maine, Maryland, Massachusetts, New Jersey, New Mexico, New York, Oregon, Pennsylvania, Rhode Island, Vermont or Washington State
NB8	Required when option code FE9 "FEDERAL EMISSIONS" is ordered for delivery to a dealer located in California, Connecticut, Massachusetts, Maryland, New Jersey, New Mexico, New York, Oregon, Pennsylvania, Rhode Island and Washington State for a purchaser who will be registering the vehicle outside California, Connecticut, Maine, Maryland, Massachusetts, New Jersey, New Mexico, New York, Oregon, Pennsylvania, Rhode Island, Vermont and Washington State.
NC7	Required when option code YF5 "CALIFORNIA EMISSIONS" or option code NE1 "CT/ME/MD/MA/NJ/NM/NY/OR/PA/RI/VT/WA EMISSIONS" is ordered for delivery to a dealer located in any state except California, Connecticut, Maine, Maryland, Massachusetts, New Jersey, New Mexico, New York, Oregon, Pennsylvania, Rhode Island, Vermont and Washington for a purchaser who will be registering the vehicle in one of these states or sold as permitted below under "EPA Policy on the Sale of California Emission Vehicles"
NB9	Required when option code YF5 is ordered for delivery to a dealer located in Connecticut, Maine, Maryland, Massachusetts, New Jersey, New Mexico, New York, Oregon, Pennsylvania, Rhode Island, Vermont and Washington. Required when option code NE1 is ordered for delivery to a dealer located in California.
Requirements for Diesel Engines in Vehicles Over 14,000 lbs GVWR: Different requirements apply to vehicles weighing over 14,000 lbs GVWR that are equipped with diesel engines. These requirements impact the Chevrolet Express and GMC Savana Vans weighing over 14,000 lbs GVWR that are equipped with the 6.6-liter Duramax diesel engine (LMM). For these vehicles, a different set of states has adopted California emission requirements, specifically, California, Connecticut, Delaware, Georgia, Maine, New Jersey, North Carolina and Pennsylvania. And GM has established a different set of emission options for use by dealers as follows.	
CEJ	FEDERAL EMISSIONS. Use for ordering vehicles that will be registered in all states except California, Connecticut, Delaware, Georgia, Maine, New Jersey, North Carolina and Pennsylvania.
YF5	CALIFORNIA EMISSIONS. Use for ordering vehicles that will be registered in California. Note: No 14,200 lb product offering available except for models with option packages ANC, B3D, YF1, or YF2
CEI	CT/DE/GA/ME/NJ/NC/PA EMISSIONS. Use for ordering vehicles that will be registered in Connecticut, Delaware, Georgia, Maine, New Jersey, North Carolina and Pennsylvania. Note: No 14,200 lb product offering available except for models with option packages ANC, B3D, YF1, or YF2.
GM has also established a different set of emission overrides as follows.	
CEK	Required when option code CEJ "FEDERAL EMISSIONS" is ordered by a dealer located in California, Connecticut, Delaware, Georgia, New Jersey, North Carolina and Pennsylvania for a purchaser who will be registering the vehicle outside California, Connecticut, Delaware, Georgia, Maine, New Jersey, North Carolina and Pennsylvania. Do not use for vehicles that will be registered in California, Connecticut, Delaware, Georgia, Maine, New Jersey, North Carolina or Pennsylvania.
CEM	Required when option code YF5 "CALIFORNIA EMISSIONS" or option code CEI "CT/DE/GA/ME/NJ/NC/PA EMISSIONS" is ordered by a dealer located in any state except California, Connecticut, Delaware, Georgia, New Jersey, North Carolina and Pennsylvania.

DIMENSIONS (in./mm)		
LOCATION	CK20743 4X4 CREW CAB STANDARD BOX	CK20943 4X4 CREW CAB LONG BOX
Wheelbase	153.70/3904	167.70/4260)
Overall length	240.20/610	259.10/6581
Body width	80.00/2032	80.00/2032
Overall height	78.10/1984	78.10/1984
Head room, front	41.30/1049	41.30/1049
Head room, rear	40.60/1031	40.60/1031
Shoulder room, front	65.20/1656	65.20/1656
Shoulder room, rear	65.20/1656	65.20/1656
Hip room, front	60.30/1532	60.30/1532
Hip room, rear	65.50/1664	65.50/1664
Leg room, front	41.30/1049	41.30/1049
Leg room, rear	39.00/991	39.00/991
Cab to axle	41.60/1057	55.60/1412
Front bumper to axle	38.80/986	38.80/986
Rear bumper to axle	52.60/1336	52.60/1336
Inside length, at floor	78.80/2002	97.80/2484
Inside height	21.00/533	21.00/533
Inside width, at floor	62.50/1588	62.50/1588
Tailgate width, top	61.60/1565	61.60/1565
Front bumper to back of cab	150.90/3833	150.90/3833
Ground to top of rear load floor	37.90/963	37.80/960
Inside width, between wheelhousing	50.60/1285	50.60/1285
Ground clearance, front	9.75/248	9.75/248
Ground clearance, rear	8.20/208	8.20/208







Note: Published dimensions indicated are without optional equipment or accessories. Additional accessories or equipment ordered at the customer's request can result in a minor change in these dimensions.

SEATS AND INTERIOR TRIM				
SEAT TYPE		SEAT OPTION	SEAT TRIM	INTERIOR DARK TITANIUM
STANDARD WORK TRUCK	Front: 40/20/40 split-bench with fold-down armrest Rear: 60/40 folding bench	AE7	Vinyl†	88V
OPTIONAL WORK TRUCK	Front: 40/20/40 split-bench with fold-down armrest and manual driver lumbar Rear: 60/40 folding bench	AE7	Cloth††	88B

†- Vinyl seats require BG9 Black rubberized-vinyl floor covering
 ††- Seats are Ebony seating surfaces and Ebony bolsters



























6 | SILVERADO 2500HD CREW CAB 4WD WORK TRUCK - 1WT

AVAILABLE EXTERIOR COLORS

							
Taupe Gray Metallic	Sheer Silver Metallic	Imperial Blue Metallic	Black	Blue Granite Metallic	Summit White	Steel Green Metallic	Victory Red

Actual colors may vary

SEO PAINT AVAILABLE

WA#	COLOR DESCRIPTION		CODE
228A	Light Autumnwood Metallic		
253A	Wheatland Yellow		9W3
334D	Dark Toreador Red		
382E	Pewter		
454N	Blue		
769H	Blue		
770H	Orange		
815K	Arrival Blue		
926L	Silver Burch Metallic		
5248	Yellow		
5405	Blue Metallic		
5445	Yellow		
5456	Yellow		
5663	Blue		
5758	Green		
7154	Blue		
7159	Blue Metallic		
7840	Gray Metallic		
7941	Green		
9015	Woodland Green		9V5
9403	Doeskin Tan		9V9
9414	Yellow		
9417	Tangier Orange		9W4
9419	Orange		
9539	Green Metallic		
9792	Indigo Blue		

ACTUAL COLOR MAY VARY

Note:

- Door handles and mirrors will be Flat Black. Deletes standard/package body side moldings.
- All normally body-colored non-sheet metal parts, will be Flat Black
- SEO paint orders that contain less than five vehicles will be delayed until five unit minimum is received for batch production

Special paint also available through Kerr Industries

- Special paint is also available for PPV and 5W4 Tahoes.
- This work is done as part of the Kerr Industries dealer direct program
- A minimum order is not required with this program. Please see the Kerr Industries CD for further details or you can contact Kerr Industries at 905-725-6561 to discuss your requirements

AVAILABLE OPTIONS

KW1	ALTERNATOR, 160 AMPS - Included with VYU Snow Plow Prep Package when L96 Vortec 6.0L V8 SFI engine is ordered; requires L96 Vortec 6.0L V8 SFI engine
K76	ALTERNATOR, DUAL, 125 AMPS EACH - Requires LML/LGH Duramax 6.6L turbo diesel V8 engine
US8	AUDIO SYSTEM - AM/FM stereo with MP3 compatible CD player, seek-and-scan, digital clock, auto-tone control, Radio Data System (RDS), speed-compensated volume and theftlock, required with U2K XM Radio.
8S3	BACKUP ALARM, 97 DECIBELS - Not available with RPO UY2 wiring provisions
SFV	BACKUP ALARM CALIBRATION - Provides calibration to disable backup lamps portion of perimeter lamps, this calibration will allow installation of an aftermarket backup alarm, not available with SEO 8S3 backup alarm or UY2 trailering wiring provisions
TP2	BATTERY, AUXILIARY HEAVY-DUTY - 600 cca, maintenance-free; not available with LML or LGH Duramax 6.6L turbo diesel V8 engine.
6C5	BATTERIES, SINGLE - 730 cca provides a heavy-duty 730 cca battery, replacing the standard 600 cca battery (requires RPO L96 Vortec 6.0L V8 SFI engine; not available with RPO TP2 auxiliary battery)
TUV	BATTERY, HEAVY-DUTY DUAL 730 CCA MAINTENANCE-FREE - Rundown protection and retained accessory power (included and only available with LML/LGH Duramax 6.6L turbo diesel V8 engine)
UPF	BLUETOOTH FOR PHONE¹⁰ - Personal cell phone connectivity to vehicle audio system; includes K34 cruise control, UK3 steering wheel-mounted audio controls and NP5 leather-wrapped steering wheel, requires UE1 OnStar ⁸ and US8 AM/FM stereo with MP3 compatible CD player, not available with UE0 OnStar delete or UM7 AM/FM stereo
K40	BRAKE, EXHAUST - Included and only available with LML or LGH Duramax 6.6L turbo diesel V8 engine
JL1	BRAKE CONTROLLER, INTEGRATED TRAILER - (With E63 fleetside pickup box, requires Z82 heavy-duty trailering equipment)
VF7	BUMPER, REAR DELETE - (Vehicles registered in certain states must have a rear bumper to be operated on their roads, consult local laws) (not available with Z82 heavy-duty trailering equipment, PCW Safety Package, SAF spare tire lock or ZW9 pickup box delete)
5V1	CARRIER WITH SPARE WHEEL - NO TIRE - Includes spare wheel and tire carrier with a spare wheel but with no spare tire; requires models **209*3 and RPO ZW9 pickup box delete, not available with RPO ZIZ spare tire or SEO 4GK spare tire
V10	COVERS, RADIATOR GRILLE AND FRONT BUMPER OPENINGS - For diesel engines in winter weather (requires LML/LGH Duramax 6.6L turbo diesel V8 engine and is required on orders with "ship to" locations within the following states: Maine, New Hampshire, Vermont, Minnesota, North Dakota, South Dakota, Montana, Alaska, Idaho, Wisconsin, Wyoming, Michigan, Colorado and New York)
K34	CRUISE CONTROL, ELECTRONIC - Set and resume speed, located on steering wheel; included with UPF Bluetooth for phone ¹⁰
9R1	DECAL DELETE, PICKUP BOX - Deletes either the "4x4" or "Z71" decal from the side of the pickup box (requires E63 fleetside pickup box; not available with SEO 8F2 ornamentation delete)
9M4	DECAL DELETE, TAILGATE - Deletes all nameplates and decals on the pickup box tailgate (requires RPO E63 fleetside pickup box; not available with SEO 8F2 ornamentation delete)
C49	DEFOGGER - Rear-window electric
G80	DIFFERENTIAL, REAR - Heavy-duty automatic locking rear
LML	ENGINE - Duramax 6.6L turbo diesel V8, B20-diesel compatible (397 hp [296.0 kW] @ 3000 rpm, 785 lb-ft of torque [1032.8 N-m] @ 1600 rpm); requires MW7 Allison 1000 6-speed automatic transmission, includes K40 exhaust brake, TUV heavy-duty dual, 730 cca battery and K05 engine block heater, not available with ZW9 pickup box delete
LGH	ENGINE - Duramax 6.6L V8 turbo diesel V8, B20-diesel compatible (335 hp [249.8 kW] @ 3100 rpm, 685 lb-ft of torque [924.8 N-m] @ 1800 rpm); requires MW7 Allison 1000 6-speed automatic transmission and ZW9 pickup box delete, includes K40 exhaust brake, TUV heavy-duty dual, 730 cca battery and K05 engine block heater
K05	ENGINE BLOCK HEATER
5H5	FIRE EXTINGUISHER - A 2.5 lb. dry chemical fire extinguisher; shipped loose in cab area for later placement and securing in after-market installation
B30	FLOOR COVERING, COLOR-KEYED CARPETING - Rubberized-vinyl floor mats (extended and crew cab models also include rear floor mats) (requires 88B Dark Titanium cloth seat trim)
AJ1	GLASS, SOLAR-RAY DEEP-TINTED - All windows except light-tinted glass on windshield and driver and front passenger side glass with crew cab models or C49 rear window defogger, includes light-tinted rear window
9B9	GOVERNOR 70 MPH - Provides electronic software to facilitate 70 mph maximum road speed
7Z1	HORN, HIGH NOTE - High note horn in addition to the base low note horn
8V2	JACK AND TOOLS DELETE - Deletes the jack and tire change tools that are standard (requires a fleet or government sales order)
5H1	KEY EQUIPMENT - 2 additional spare keys for a total of 4 vehicle keys; requires RPO E63 pickup box and RPO SAF spare tire lock. Not available with SEO AU0 remote keyless entry
8X1	LABEL, FASTEN SAFETY BELTS - "Fasten safety belts" reminder label on side door window glass

8. Visit OnStar.com for coverage map, system limitations and details.

10. Go to gm.com/bluetooth to find out which Bluetooth phones are compatible with the vehicle.

AVAILABLE OPTIONS (CONTINUED)

U01	LAMPS, SMOKED AMBER ROOF MARKER - (Not available with YF5 California state emissions requirements)
VK3	LICENSE PLATE BRACKET, FRONT - (Will be forced on orders with "ship to" states that require a front license plate)
VAV	FLOOR MATS, ALL-WEATHER - Ebony deep ribbed rubber (extended and crew cab models also include rear floor mats); requires B30 color-keyed carpeting, not available with BG9 Black rubberized-vinyl floor covering
W03	HEATED SEATS KIT - Driver and front passenger; not available with ZW9 pickup box delete
C7A	GVWR⁵ - 10,000 lbs. (4536 kg); requires LML or LGH Duramax 6.6L turbo diesel V8 engine
9N8	MIRRORS, AUXILIARY DRIVER AND PASSENGER SIDE 6" (15.2 CM) DIAMETER CONVEX SPOT ADD-ON, STAINLESS STEEL - With brackets for use with SEO 9F7 west coast style mirrors; mirrors shipped loose in vehicle; (requires SEO 9F7 outside driver and passenger side west coast type, mirrors)
6P3	MIRRORS, CAMPER, POWER-ADJUSTABLE GLASS, MANUAL EXTENDABLE, HEATED - Alternative mirrors replacing mirrors that are standard with SEO 5B5 power windows, locks and mirrors on a base decor truck; provides RPO DPN outside heated power-adjustable manual folding vertical camper mirrors consisting of 50 square inch flat mirror surface positioned over a 20 square inch convex mirror surface with a common head; includes turn signals in mirror glass; (requires SEO 5B5 power window locks and mirrors; this option must be ordered and priced in addition to SEO 5B5)
9F7	MIRRORS, OUTSIDE DRIVER AND PASSENGER SIDE WEST COAST TYPE - Provides large west coast style mirrors with spring loaded pre-set feature; mirrors are Black; includes cab drillings and mirror assembly shipped loose; (not available with SEO 5B5 power windows locks and mirrors)
DL8	MIRRORS, OUTSIDE HEATED POWER-ADJUSTABLE - Black, manual-folding, included and only available with SEO 5B5 power windows, locks and mirrors
DF2	MIRRORS, OUTSIDE HIGH-VISIBILITY VERTICAL CAMPER-STYLE, BLACK - Manual folding and extension and lower convex spotter glass
R8G	ONSTAR⁸ - 1 Additional Year of Safe and Sound Service. Provides 1 year of Safe and Sound service following the first year of OnStar service included in the price of the vehicle. Fleet may also order RFA OnStar Business Vehicle Manager Service; requires UE1 OnStar 1-year Safe and Sound plan. Requires one of the following Fleet or Government order types: FLS, FNR, FRC, FBC, FGO or FEF. Not available with R8P, R8W, R8Y, R8Z, RFG or RFH.
UE1	ONSTAR⁸ - 1-year of Directions and Connections plan, OnStar services require vehicle electrical system (including battery), wireless service and GPS satellite signals to be available and operating for features to function properly. OnStar acts as a link to existing emergency service providers. Turn-by-Turn Navigation requires ABS and Directions and Connections plan. Not available in certain areas. Visit onstar.com for coverage map. Vehicle Diagnostics capabilities vary by model. Remote door unlock success varies with conditions. Ability to locate stolen vehicles varies with conditions. Subscription Service Agreement required. Call 1-888-40ONSTAR (1-888-466-7827) or visit onstar.com for OnStar's Terms and Conditions, Privacy Policy and details and system limitations.
R8W	ONSTAR⁸ - 1-Year Directions and Connections Service. Provides an upgrade from Safe and Sound service included in the price of the vehicle in the first year. Fleet may also order RFA OnStar Business Vehicle Manager Service; requires UE1 OnStar 1-year Safe and Sound plan. Requires one of the following Fleet or Government order types: FLS, FNR, FRC, FBC, FGO or FEF. Not available with R8G, R8P, R8Y, R8Z, RFG or RFH.
R8P	ONSTAR⁸ - 2 Additional Years of Safe and Sound Service. Provides 2 additional years of Safe and Sound service following the first year of OnStar service included in the price of the vehicle. Fleet may also order RFA OnStar Business Vehicle Manager Service; requires UE1 OnStar 1-year Safe and Sound plan. Requires one of the following Fleet or Government order types: FLS, FNR, FRC, FBC, FGO or FEF. Not available with R8G, R8W, R8Y, R8Z, RFG or RFH.
R8Y	ONSTAR⁸ - 2-Years Directions and Connections Service. Provides cumulative 2 Years of Directions and Connections service. In the first year, this is an upgrade from Safe and Sound service included in the price of the vehicle. Fleet may also order RFA OnStar Business Vehicle Manager Service; requires UE1 OnStar 1-year Safe and Sound plan. Requires one of the following Fleet or Government order types: FLS, FNR, FRC, FBC, FGO or FEF. Not available with R8G, R8P, R8W, R8Z, RFG or RFH.
R8Z	ONSTAR⁸ - 3-Years Directions and Connections Service Provides cumulative 3 Years of Directions and Connections service. In the first year, this is an upgrade from Safe and Sound service included in the price of the vehicle. Fleet may also order RFA OnStar Business Vehicle Manager Service; requires UE1 OnStar 1-year Safe and Sound plan. Requires one of the following Fleet or Government order types: FLS, FNR, FRC, FBC, FGO or FEF. Not available with R8G, R8P, R8W, R8Y, RFG or RFH.
RFG	ONSTAR⁸ - 3 Additional Years Safe and Sound Service. Provides 3 additional Years of Safe and Sound service following the first year of OnStar service included in the price of the vehicle. Fleet may also order RFA OnStar Business Vehicle Manager Service; requires UE1 OnStar 1-year Safe and Sound plan. Requires one of the following Fleet or Government order types: FLS, FNR, FRC, FBC, FGO or FEF. Not available with R8G, R8P, R8W, R8Y, R8Z or RFH.
RFH	ONSTAR⁸ - 4 Additional Years Safe and Sound Service. Provides 4 additional Years of Safe and Sound service following the first year of OnStar service included in the price of the vehicle. Fleet may also order RFA OnStar Business Vehicle Manager Service; requires UE1 OnStar 1-year Safe and Sound plan. Requires one of the following Fleet or Government order types: FLS, FNR, FRC, FBC, FGO or FEF. Not available with R8G, R8P, R8W, R8Y, R8Z or RFG.
RFA	ONSTAR⁸ - Business Vehicle Manager Service. Provides OnStar Business Vehicle Manager Service equal to the length of OnStar service, requires one of the following Fleet or Government order types: FLS, FNR, FRC, FBC, FGO or FEF.
8F2	ORNAMENTATION, DELETE - Deletes decals and nameplates on truck exterior
9V9	PAINTS, SOLID - Doeskin Tan all normally body-colored non-sheet metal parts will be Flat Black. Door handles and mirrors will be Flat Black. This deletes the standard/packaged body-side moldings; requires TGK Special Paint and 01U Special Paint .
9W4	PAINTS, SOLID - Tangier Orange all normally body-colored non-sheet metal parts will be Flat Black. Door handles and mirrors will be Flat Black. This deletes the standard/packaged body-side moldings; requires TGK Special Paint and 01U Special Paint .
9W3	PAINTS, SOLID - Wheatland Yellow all normally body-colored non-sheet metal parts will be Flat Black. Door handles and mirrors will be Flat Black. This deletes the standard/packaged body-side moldings; requires TGK Special Paint and 01U Special Paint .
9V5	PAINTS, SOLID - Woodland Green all normally body-colored non-sheet metal parts will be Flat Black. Door handles and mirrors will be Flat Black. This deletes the standard/packaged body-side moldings; requires TGK Special Paint and 01U Special Paint

5. Gross Vehicle Weight Rating (GVWR). When properly equipped, includes vehicle, passengers, cargo and equipment.

8. Visit OnStar.com for coverage map, system limitations and details.

AVAILABLE OPTIONS (CONTINUED)

TGK	PAINT, SOLID, SPECIAL - one color all normally body-colored non-sheet metal parts will be Flat Black. Door handles and mirrors will be Flat Black. This deletes the standard/packaged body-side moldings; requires 01U Special Paint with any special paint selection. May require an extended lead time. RPO B85 body-colored body side moldings, will be deleted when SEO TGK special paint is ordered.
9L4	POWER SUPPLY, 12-VOLT DIRECT POWER SUPPLY FROM THE BATTERY - With two (2) separate 30-amp fused circuits; each circuit has a 30-amp mini-fuse for both positive and ground to protect electrical accessories; main supply lead has a 60-amp maxi-fuse; all fuses are serviceable; provides either direct battery power or operation through the ignition system; hook-up wire is located at the front of the floor console; operational amperage is 21-amps each circuit, 42-amps total; hook-up and operational instructions are provided; (requires a fleet of government sales order; requires RPO UE0 OnStar delete and RPO U2J XM Satellite Radio delete; not available with RPO U42 entertainment system, RPO TP2 auxiliary heavy-duty battery, RPO LML/LGH Duramax 6.6L turbo diesel V8 engine or RPO JF4 power-adjustable pedals)
5B5	POWER WINDOWS, LOCKS AND MIRRORS, WITH UPLEVEL DOOR PANELS ON A BASE TRIM LEVEL VEHICLE - Provides power driver and passenger front side windows with uplevel door panels on a base level vehicle; includes RPO DL8 outside heated power-adjustable manual folding mirrors, RPO AU3 power door locks and RPO UQ3 speaker system audio system feature; C/K***43 models include rear door power windows and locks; power mirrors can be upgraded to SEO 6P3 camper, power-adjustable glass, manual extendable, heated mirrors; (RPO AU0 remote keyless entry becomes optional on all models and must be ordered and priced if desired) (not available with C42 air conditioning delete)
TRW	PROVISION FOR CAB ROOF-MOUNTED LAMP/BEACON - Provides an instrument panel-mounted switch and electrical wiring tucked beneath the headliner for a body upfitter to connect a body-mounted warning or emergency lamp; 30-amp nominal rating (not available with PDD Convenience Package, CF5 power sunroof or UG1 universal home remote; included with VYU Snow Plow Prep Package)
GT5	REAR AXLE - 4.10 ratio (requires L96 Vortec 6.0L V8 SFI engine)
AU0	REMOTE KEYLESS ENTRY - With 2 transmitters, panic button and content theft alarm, optional on all models when SEO 5B5 power windows, locks and mirrors is ordered; (requires SEO 5B5 power windows, locks and mirrors)
5H6	SAFETY REFLECTOR TRIANGLE KIT - Break-down warning kit consisting of three (3) reflective triangles; shipped loose in the cab area for later placement and securing in after-market installation
88B	SEAT TRIM - Dark Titanium cloth
AM1	SEAT ADJUSTER, MANUAL LUMBAR CONTROL ON THE DRIVERSIDE - (Included and only available with 88B Dark Titanium cloth seat trim)
9U3	SEATS, DRIVER AND PASSENGER FRONT INDIVIDUAL SEATS IN CLOTH TRIM - Derived from RPO AE7 40/20/40 split-bench with center 20% section removed; seats are manual, not power and include driver's side only lumbar; does not include floor console; exposed floor areas will remain untrimmed; cloth rear seats with trim matching front seats will be provided on extended and crew cab models; (requires trim code 88B Dark Titanium)
9S1	SEATS, DRIVER AND PASSENGER FRONT INDIVIDUAL SEATS IN VINYL TRIM - Derived from RPO AE7 40/20/40 split-bench with center 20% section removed; seats are manual, not power; does not include floor console; exposed floor areas will remain untrimmed; standard vinyl rear seat with trim matching front seats will be provided on crew cab models (requires trim code 88V Dark Titanium)
9U5	SINGLE BULB TAIL LAMP CALIBRATION - For bulb outage detection used on aftermarket bodies. Requires ZW9 box delete
NZZ	SKID PLATE PACKAGE, FRAME-MOUNTED SHIELDS - Includes front underbody shield starting behind front bumper and running to first cross member, protecting front underbody, oil pan, differential case and transfer case (included with VYU Snow Plow Prep Package)
VYU	SNOW PLOW PREP PACKAGE - Includes 10-amp power for backup and roof emergency lamp, high-flow front bumper, forward lamp wiring harness, TRW provision for cab roof mounted lamp/beacon, instrument panel jumper wiring harness for electric trailer brake controller and NZZ Skid Plate Package; requires 4WD models. Includes KW1 160-amp alternator with L96 Vortec 6.0L V8 SFI engine. Includes K76 dual 125-amp alternators with LML/LGH Duramax 6.6L turbo diesel V8 engine
9L3	SPARE TIRE DELETE - Deletes the spare tire only; spare wheel and carrier remain; (requires E63 pickup box)
SAF	SPARE TIRE LOCK - Keyed cylinder lock that utilizes same key as ignition and door (not available with ZW9 pickup box delete or VF7 rear bumper delete)
5Z4	SPARE WHEEL AND CARRIER DELETE - Deletes the base spare wheel and carrier; does not delete jack or tools (requires SEO 9L3 spare tire delete and RPO E63 pickup box; not available with RPO SAF spare tire lock)
VXH	STEPS ASSIST, CHROMED TUBULAR - 6" oval (dealer installed); not available with VXJ 3" round tubular assist steps,
VXJ	STEPS ASSIST, CHROMED TUBULAR - 3" round (dealer installed); not available with VXH 6" oval tubular assist steps or LML/LGH Duramax 6.6L turbo diesel V8 engine
UF3	SWITCH, HIGH IDLE - (Requires K34 cruise control)
ZXT	TIRE, SPARE - LT265/70R17E all-terrain, blackwall; included and only available with QXT LT265/70R17E all-terrain, blackwall tires. Available to order when ZW9 pick-up box delete is ordered
ZWF	TIRE, SPARE - LT265/70R18E all-season, blackwall; included and only available with QGM LT265/70R18E all-terrain tires or QWF LT265/70R18E all-season tires. Available to order when ZW9 pickup box delete is ordered

AVAILABLE OPTIONS (CONTINUED)

QGM	TIRES - LT265/70R18E all-terrain, blackwall; requires PYT 18" (45.7 cm) painted steel wheels
QVF	TIRES - LT265/70R18E all-season, blackwall; requires PYT 18" (45.7 cm) painted steel wheels
Z82	TRAILERING EQUIPMENT, HEAVY-DUTY - Includes trailering hitch platform and 2.5-inch receiver with 2-inch adapter, 7-wire harness (harness includes wires for: park lamps, backup lamps, right turn, left turn, electric brake lead, battery and ground) with independent fused trailering circuits mated to a 7-way sealed connector, wiring harness for after-market trailer brake controller (located in the instrument panel harness), and single wire for center high-mounted stop lamp (not available with ZW9 pickup box delete or VF7 rear bumper delete)
MW7	TRANSMISSION, ALLISON 1000 6-SPEED AUTOMATIC, ELECTRONICALLY CONTROLLED - Overdrive, electronic engine grade braking and tow/haul mode (requires LML/LGH Duramax 6.6L turbo diesel V8 engine)
ZHQ	TIRE, SPARE - LT245/75R17E all-season, blackwall; included with QHQ LT245/75R17 all-season, blackwall tires. Available to order when ZW9 pickup box delete is ordered
UY2	TRAILERING WIRING PROVISIONS, FOR CAMPER, FIFTH WHEEL AND GOOSENECK TRAILER - includes additional 7-way wiring harness routed to front of pickup box; requires Z82 heavy-duty trailering equipment
U2K	XM RADIO⁹ - Includes three trial months of service; requires US8 AM/FM stereo with MP3 compatible CD player and UE1 OnStar ⁸ . XM service available only in the 48 contiguous United States and the District of Columbia. XM Radio subscription required and sold separately after trial period. Fees, taxes, and a one-time re-activation fee, may apply. Subscriptions governed by XM Customer Agreement available at xmradio.com. All fees and programming subject to change. Family programming packages are available
PYN	WHEELS - 4-17" x 7.5" (43.2 cm x 19.1 cm) 8-lug chrome-styled steel, includes chrome center caps and steel spare (spare wheel will not cosmetically match the other 4 wheels) spare not included with ZW9 pickup box delete unless a spare tire is ordered
PYT	WHEELS - 18" (45.7 cm) painted steel
PYP	WHEELS - 17" (43.2 cm) chrome-clad steel; includes NZ4 17" x 7.5" (43.2 cm x 19.1 cm) steel spare wheel. Spare not included with ZW9 pickup box delete unless a spare tire is ordered

8. Visit OnStar.com for coverage map, system limitations and details.

9. XM Radio requires a subscription, sold separately by XM after the trial period. Not available in Canada, Alaska or Hawaii. For more information, visit gm.xmradio.com.

CREW CAB SPECIFICATIONS		
	CK20743 4X4 CREW CAB STANDARD BOX	CK20943 4X4 CREW CAB LONG BOX
SPECIFICATIONS		
Front shock absorber diameter, in. (mm)	1.38 (35)	1.38 (35)
Front stabilizer bar diameter, in. (mm)	1.31 (33)	1.31 (33)
Rear shock absorber diameter, in. (mm)	1.38 (35)	1.38 (35)
Turning diameter, curb-to-curb, ft. (m)	50.5 (15.4)	54.8 (16.7)
CAPACITIES		
Front axle, L96, lbs. (kg)	4800 (2177)	4800 (2177)
Front axle, LML/LGH, lbs. (kg)	5200 (2359)	5600 (2540)
Front spring capacity, L96, lbs. (kg)	4800 (2177)	4800 (2177)
Front spring capacity, LML/LGH, lbs. (kg)	5200 (2177)	5600 (2540)
Rear axle, lbs. (kg)	6200 (2812)	6200 (2812)
Rear spring capacity, lbs. (kg)	6200 (2812)	6200 (2812)
Curb weight (L96 engine), lbs. (kg)	6377 (2893)	6525 (2960)
Curb weight (LML/LGH engine), lbs. (kg)	7208 (3270)	7387 (3351)
Cargo volume ³ , cargo box, cu. ft. (liters)	60.7 (1719.0)	75.5 (2138.2)
Payload ⁶ , L96, lbs. (kg)	3123 (1417)	3375 (1531)
Payload ⁶ , LML/LGH, lbs. (kg)	2792 (1266)	2613 (1185)
Gross Vehicle Weight Rating ⁵ (GVWR), L96, lbs. (kg)	9500 (4309)	9900 (4491)
Gross Vehicle Weight Rating ⁵ (GVWR), LML/LGH lbs. (kg)	10000 (4536)	10000 (4536)
Front Gross Axle Weight Rating (FGAWR), L96, lbs. (kg)	4400 (1996)	4800 (2177)
Front Gross Axle Weight Rating (FGAWR), LML/LGH, lbs. (kg)	5200 (2359)	5600 (2540)
Rear Gross Axle Weight Rating, lbs. (kg)	6200 (2812)	6200 (2812)
Fuel capacity, approximate, gallon (liters)	36 (136)	36 (136)
Seating capacity	6	6

AUTOMATIC TRANSMISSION - WITH BALL HITCH				
MODEL	(L96) VORTEC 6.0L VARIABLE VALVE TIMING V8 SFI		(LML) DURAMAX 6.6L TURBO DIESEL V8	
	AXLE RATIO WEIGHT LBS. (KG)	MAXIMUM TRAILERING ⁷	AXLE RATIO WEIGHT LBS. (KG)	MAXIMUM TRAILERING ⁷
CK20743	3.73	9400 (4264)	3.73	13000 (5897)
	4.10	13000 (5897)	—	—
CK20943	3.73	9300 (4218)	3.73	13000 (5897)
	4.10	13000 (5897)	—	—

*Addition of trailer tongue weight cannot cause vehicle weights to exceed Rear Gross Axle Weight Rating (RGAWR) of Gross Vehicle Weight Rating (GVWR)⁵.
(282) Trailering equipment, heavy-duty, includes trailer hitch platform and trailer electrical connector.*

GCWR - ENGINE/REAR AXLE RATIO COMBINATION WITH AUTO TRANSMISSION			
ENGINE	(GCWR) GROSS COMBINATION WEIGHT RATINGS lbs. (kg)		
	16,000 (7,258)	20500 (9299)	24500 (11113)
L96 Vortec 6.0l variable valve timing V8 SFI	3.73	4.10	—
LML/LGH Duramax 6.6L turbo diesel V8	—	—	3.73

3. Cargo and load capacity limited by weight and distribution.

5. Gross Vehicle Weight Rating (GVWR). When properly equipped, includes vehicle, passengers, cargo and equipment.

6. Maximum payload capacity includes weight of driver, passengers, optional equipment and cargo.

7. Maximum trailer weight ratings are calculated assuming a base vehicle, except for any option(s) necessary to achieve the rating, plus driver.

The weight of other optional equipment, passengers and cargo will reduce the maximum trailer weight your vehicle can tow.

Can specialty vehicle equipment (e.g. radar devices, video cameras, computers, meters, radio trees, shotguns, etc.) still be mounted in cars with passenger side air bags?

Yes, but care must be taken to mount the equipment outside of the deployment zone. Air bags inflate with great force and will interact with any object in the deployment zone. Therefore, to reduce the risk of injury to vehicle occupants, GM recommends that the air deployment zone be kept free of any equipment. If a piece of equipment were to become dislodged it could strike an occupant in the vehicle and result in injury. The likelihood of an object becoming dislodged is influenced by many factors, including the proximity of the object to the inflatable restraint, the size and shape of the object, and the means by which the object is secured to the vehicle. In addition to these factors, the trajectory and velocity of a dislodged object can be influenced by the type and severity of vehicle crash.

Objects that are in the deployment zone, but do not become dislodged by an inflating air bag can still affect the performance of the air bag. For example, such objects could tear the fabric or affect the shape of the air bag, thus reducing the ability of the bag to provide restraint.

Is it possible to shield equipment that is installed in the passenger side frontal air bag deployment zone in a manner that will allow full and safe air bag deployment?

Due to the complexity of influencing variables, GM is unable to evaluate the potential for shielding expected equipment configurations in all accident scenarios in order to assure that the air bag performance would be unaffected. While shielding may protect certain equipment from being damaged or dislodged, it may also negatively affect the inflation characteristics of the air bag. The air bag's shape, inflation angle, fold pattern, and inflation rate and pressure are developed to maximize the protection capability of the inflatable restraint system. Therefore, GM cannot recommend the placement of any equipment in the deployment zone, even if it is shielded to protect it from damage.

Front air bag systems and instrument panel mounted equipment.

Passenger air bags in GM vehicles deploy in different ways depending upon the type of vehicle and the particular instrument panel design.

In some vehicles, the passenger air bag deploys through a discrete door located on the top surface of the instrument panel (top-mount air bag systems). In other vehicles, such as the Chevrolet Tahoe, the passenger air bag deploys through a discrete door mounted on the vertical rearward surface of the instrument panel, above the glove box door (mid-mount air bag system). With these types of top-mount and mid-mount passenger air bag systems, the top pad of the instrument panel remains in place during deployment.

Some GM passenger air bag systems, like the system in the Chevrolet Impala, deploy from beneath the instrument panel top pad. These are considered 3/4-mount air bag systems with a "deployable top pad." The entire instrument panel top pad is the "deployment door" from under which the inflating air bag emerges. When an air bag deployment is commanded, the forces from the inflating passenger air bag push up on the instrument panel top pad, releasing special fasteners across the rearward edge of the top pad. This allows the top pad to rotate upward so that the passenger air bag may emerge. The top pad rotates upward to open widest at the right hand side, and is usually forced upward into contact with the windshield on the right hand side of the vehicle during a deployment.

Head curtain side air bags are designed to help reduce the risk of head and neck injuries to front and rear seat occupants on the near side of certain side-impact collisions. Always use safety belts and the correct child restraints for your child's age and size, even in vehicles equipped with air bags. Children are safer when properly secured in a rear seat. See your vehicle Owner's Manual and child safety seat instructions for more information.

Instrument panel top mounted special equipment, such as a radar antenna and control unit or video camera must be positioned to the left of the vehicle center line. This equipment must be mounted as low as possible and securely fastened to the top pad to avoid being dislodged in the event of a crash and possible air bag deployment. In the process of securely fastening special equipment to the top, DO NOT fasten down the top pad itself to any other vehicle component such as the cluster trim plate. As described above, the top pad rotates upward during a deployment. In order to enable the proper deployment of the passenger air bag, specialty equipment installation MUST NOT PREVENT the top pad from rotating upward during deployment. Location and attachment of special equipment should minimize added resistance or interference to upward rotation of the top pad during deployment.

Optional side air bags for crashes to the vehicle sides.

The air bag system in your police vehicle may include optional side air bags for front and rear occupants. Most front-to-rear side air bags are designed to deploy downward from the interior roof sides to the bottom of the door windows.

Can Specialty Vehicle Security Barriers be mounted within the side air bag deployment zones?

No. The side air bags inflate extremely fast because of the nature of side crashes to the vehicle. Mounting a security barrier behind the front seats with the ends placed within the side air bag deployment zones will result in unintended interaction between the barrier and the inflating side air bags. To reduce the risk of injury to the vehicle occupants, GM recommends that the side air bag zones be kept free of any customer installed equipment.

Customer furnished equipment installed to the vehicle roof.

Your police vehicle is designed with an interior roof cover system which includes internal components for the interior lamps and wiring. The roof system may also include optional side air bag components. Inflation devices may be mounted on the vehicle roof side behind the rear doors as well as air bag tethers retained to the windshield pillars. Care must be taken to avoid damage to these components or interference with their operation when installing roof mounted equipment such as emergency lamps and communication antennas.

Recommended GM service procedures must be followed to remove and re-install the instrument panel top pad to ensure that the top pad will release properly in the event of a passenger air bag deployment.

On the right half of the top pad closest to the passenger air bag module, GM recommends that no equipment be mounted. When mounting equipment on the driver side of the top pad, GM recommends that the total mass of the top pad mounted special equipment not exceed 8 pounds (3.6 kilograms), since the top pad tends to rotate about the left end.

Fasteners used to secure special equipment to the instrument panel top pad, the windshield glass, or to the windshield upper frame (header), should be selected to ensure that these devices will remain attached during a vehicle crash and possible air bag deployment.

Can the installation of push bumpers on the front end of the vehicle affect the deployment of the air bag?

General Motors is not aware of adverse effects during crash events from the many push bumpers that have been installed on GM police vehicles. Because there are many styles of push bumpers available with varying crash characteristics, installation of push bumpers may or may not affect deployment timing of the air bags. Push bumpers should be mounted to avoid modifying the vehicle structure and interfering with the front air bag sensors mounted on the upper radiator support cross member.

Two front impact sensors are installed in General Motors vehicles. Do not relocate or disconnect the front sensors. The location and orientation of the front sensors are critical for correct operation of the air bag system. Avoid mounting components on or near the sensors. Push bumper styles with vertical pushing members that are in fore-aft alignment with the front air bag sensors are not recommended.

How long will the air bag remain inflated?

It takes approximately 1/20th of a second to fully inflate the frontal air bags. This is faster than the blink of an eye. The air bags begin to deflate immediately, helping to stop the occupants more gradually.

Can the air bag system be re-used?

No. The air bags are designed to inflate only once. After inflation some new parts will be required. These will include the air bag module and possibly other parts. (A competent service technician with access to the vehicle's service manual and the required tools should replace the required components after a deployment crash.)

I've heard that the dusts that are released into the passenger compartment from the air bag are harmful. Is this true?

For most people, the only effect the dusts will produce is some irritation of the throat and eyes, and that is only if the occupant remains in the vehicle for many minutes after the air bag deployment with no ventilation and windows closed. However, some people with asthma may develop an asthmatic attack from inhaling the dusts. If this happens, they should first treat themselves the same way their doctor has advised them to treat any other asthma attack, and then immediately seek medical treatment.

When should an air bag inflate?

The driver's and right-front passenger's frontal air bags are designed to inflate in moderate to severe frontal or near-frontal crashes. But they are designed to inflate only if the impact speed is above the system's designed "threshold level."

In addition, if your vehicle has "dual stage" frontal air bags, these air bags tailor the amount of restraint according to crash severity. For moderate frontal impacts, the air bags inflate at a level less than full deployment. For more severe frontal impacts, "dual stage" frontal air bags deploy at full levels.

If the front of your vehicle goes straight into a wall that doesn't move or deform, the threshold level of the reduced deployment is about 12 to 16 mph (19 to 15 km/h), and the threshold level for a full deployment is about 18 to 24 mph (29 to 28.5 km/h). The threshold level can vary, however, with specific vehicle design, so that it can be somewhat above or below this range.

If your vehicle strikes something that will move or deform such as a parked car, the threshold level will be higher. The driver's and right-front passenger's frontal air bags are not designed to inflate in rollover, side impacts, or rear impacts, because inflation would not help the occupant.

Head curtain side air bags are designed to help reduce the risk of head and neck injuries to front and rear seat occupants on the near side of certain side-impact collisions. Always use safety belts and the correct child restraints for your child's age and size, even in vehicles equipped with air bags. Children are safer when properly secured in a rear seat. See your vehicle Owner's Manual and child safety seat instructions for more information.

Seat mounted side impact air bags are designed to inflate in moderate to severe side crashes. The side impact air bags will inflate if the crash severity is above the designed "threshold level." The threshold level can vary with specific vehicles design. The side impact air bags are not designed to inflate on frontal or near-frontal impacts or rear impacts, because inflation would not help the occupant.

Roof rail mounted head-curtain airbags are designed to inflate in moderate to severe side crashes. In addition, certain vehicles have head-curtain air bags which are also designed to inflate in situations where an impending rollover condition is identified by the vehicle's rollover sensing system and/or frontal or near-frontal impacts if the crash severity is above the designed "threshold level".

Safety belt pretensioners at the driver and front passenger seat positions are designed to deploy in frontal, near-frontal, side, and rear crashes that exceed the "threshold level" of crash severity to help reduce slack in the safety belt. Safety belt pretensioners will also deploy in impending rollover situations.

I've heard that a deployed air bag produces what appears to be smoke. Is the air bag hot?

After the bag has deployed in a crash, the air bag itself will not be hot to touch. Some components within the air bag module will be hot for a short time. A small amount of smoke coming from a deployed air bag module is normal and should not be cause for concern.

Also, when the nitrogen gas is vented out of the air bag, small particles from inside the bag are also vented into passenger compartment. These airborne particles look like smoke and some particles are deposited as residue on and around the air bag.

If my vehicle has air bags, why should I have to wear my safety belt?

Air bags are in many vehicles today and will be in most of them in the future. But they are supplemental systems only; so they work with safety belts - not instead of them. Every air bag system ever offered for sale has required the use of safety belts. Even if you're in a vehicle that has air bags, you still have to buckle up to get the most protection. That's true not only in frontal collisions but especially in side and other collisions.

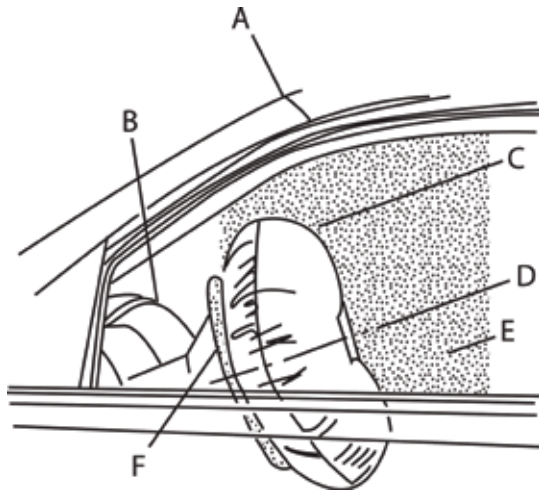

SIDE VIEW OF DRIVER SIDE AIR BAG DEPLOYMENT ZONE

- A. Top edge of windshield
- B. Top of instrument panel
- C. Inflated air bag – steering wheel
- D. Centerline of steering column at mid-tilt
- E. Driver air bag deployment zone
- F. Front of steering wheel

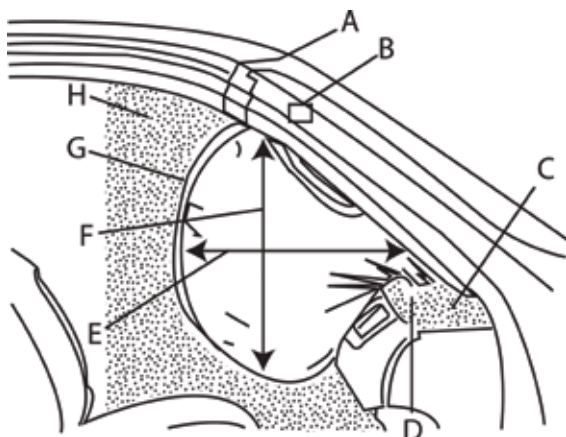

SIDE VIEW OF PASSENGER SIDE AIR BAG DEPLOYMENT ZONE

- A. Top edge of windshield
- B. Inside rearview mirror
- C. Instrument panel top surface zone
- D. Passenger side air bag module trim panel – rear edge
- E. Inflated air bag – horizontal dimension approximate 15.4 in (390 mm)
- F. Inflated air bag – vertical dimension approximate 9.3 in (490 mm)
- G. Inflated air bag – instrument panel
- H. Passenger air bag deployment zone

Head curtain side air bags are designed to help reduce the risk of head and neck injuries to front and rear seat occupants on the near side of certain side-impact collisions. Always use safety belts and the correct child restraints for your child's age and size, even in vehicles equipped with air bags. Children are safer when properly secured in a rear seat. See your vehicle Owner's Manual and child safety seat instructions for more information.

HEAD CURTAIN AND FRONT SEAT-MOUNTED SIDE IMPACT AIR BAG DEPLOYMENT ZONES
PASSENGER SIDE SHOWN, DRIVER SIDE SIMILAR

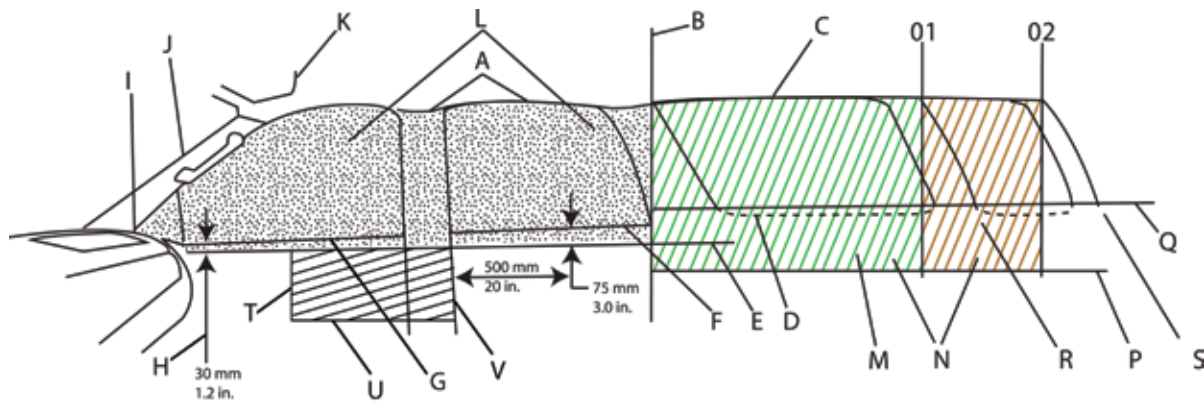

Tahoe/Suburban/Silverado Crew Cab Seat Rows 1 and 2

- A. Top of deployment zone – along head curtain at edge of headliner
- B. Back of deployment zone – at rear top corner of rear door pad
- C. Rear quarter window
- D. Bottom outside edge of rear quarter window
- E. Bottom of air bag deployment zone – parallel to outside bottom edge of rear quarter glass
- F. Top edge of rear door pad
- G. Top edge of front door pad
- H. Dimension at mirror patch from top edge of front door pad
- I. Front of deployment zone at front upper corner of front door pad
- J. Windshield pillar trim with grab handle
- K. Visor
- L. Deployment zone - Tahoe seat rows 1 and 2

Tahoe/Suburban 3rd Row Seats

- M. Deployment zone - Tahoe 3rd seat
- N. Deployment zone - Suburban 3rd seat
- O. Rear zones at back corner of headliner: 1 Tahoe, 2 Suburban
- P. Bottom of 3rd seat zone at rear side trim cup holders
- Q. Top edge of rear quarter trim at window
- R. Rear of Tahoe
- S. Rear of Suburban

Tahoe/Suburban/Silverado Crew Cab Seat Air bag

- T. Center of door trim pull handle
- U. Top of surface of outboard front seat cushion
- V. Back edge of center pillar trim

Note: The head curtain air bag inflators are mounted in a different orientation on the Silverado Crew Cab pickup truck roof structure from those in the Tahoe/Suburban.

HEAD CURTAIN AND FRONT SEAT-MOUNTED SIDE IMPACT AIR BAG DEPLOYMENT ZONES
VIEW FROM REAR CARGO AREA

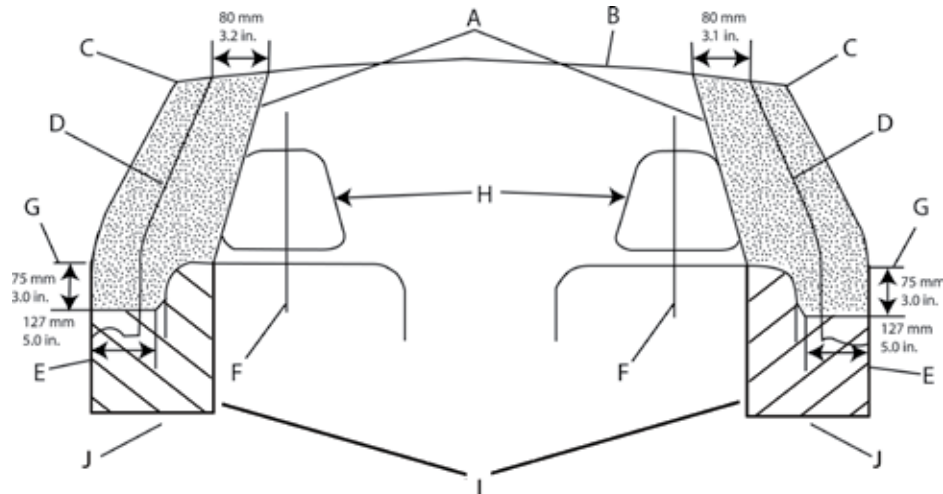

- A. Head curtain air bag deployment zone
- B. Underside of headliner
- C. Edge of headliner
- D. Inner center pillar trim
- E. Inner door pad
- F. Seat centerline
- G. Bottom of door windows
- H. Front seat headrests
- I. Seat-mounted side impact air bags deployment zone front seat
- J. Top surface of outboard front seat cushion

Head curtain side air bags are designed to help reduce the risk of head and neck injuries to front and rear seat occupants on the near side of certain side-impact collisions. Always use safety belts and the correct child restraints for your child's age and size, even in vehicles equipped with air bags. Children are safer when properly secured in a rear seat. See your vehicle Owner's Manual and child safety seat instructions for more information.

GM offers Anti-Lock Brake Systems as standard or optional on all North American passenger vehicles and light truck lines. The computerized Anti-Lock Braking System (ABS) is designed to keep the vehicle's wheels rotating as the brakes are applied to assist the driver in achieving a controlled stop. Sensors monitor how fast the wheels rotate and feed the data continuously to the ABS computer. The vehicle's brakes slow each wheel as the brake pedal is applied. However, when ABS is activated due to road conditions, the system repeatedly releases and applies pressure to the brakes. The wheels can keep rolling, thus retaining steering ability and enhanced stability while providing a higher braking force on most surfaces than a locked wheel provides.

How exactly does ABS work?

In cars without ABS, hitting the brakes can cause the wheels to lock, leaving you unable to steer the vehicle until you decrease the pressure so the wheels can roll again. With an ABS, as you apply the brakes, the ABS computer monitors the wheel speed sensor information. If the computer senses that a wheel is approaching lock up, it sends a signal to the hydraulic modulator to reduce, then to reapply, brake pressure several times a second for as long as you maintain firm pressure on the brake pedal. The process is much like the threshold braking technique used with conventional brakes. However, ABS does it much faster and more accurately than any driver can, leaving you free to focus on steering away from obstacles.

Does ABS reduce stopping distances?

Yes, in braking situations where the wheels on a non-ABS equipped vehicle would lock up, ABS will generally provide shorter controlled stopping distance. The amount of improvement in stopping distance depends on many factors, including the road surface, severity of braking, initial vehicle speed, etc. On some surfaces, such as gravel roads, braking distances can be longer, but you will still have the control benefits of ABS. The important capability of ABS is control. ABS provides improved vehicle steerability and stability when braking.

What can affect the ABS advantage?

It is important that you follow the maintenance schedule recommended in the owner's manual of the vehicle, tires should be at their proper inflation level, the brake pads should be checked regularly, etc. While driving, you should sit comfortably, so that your hips are back in the seat and your knees are bent, even while braking. Your foot should be positioned so that your heel is on the floor and your toes are secure on the lower half of the pedal. And, though ABS may reduce stopping distance, remember: The faster you go, the longer it takes you to stop. Keeping a safe distance between you and the vehicle in front of you is always necessary, even with ABS.

What happens if ABS becomes inactive?

The ABS electronic control unit has on-board diagnostic capability. If a fault is detected, the vehicle will revert to the base brake system, and the ABS telltale on the dash will be illuminated. Should this happen, the vehicle should be taken to a dealership for repair as soon as possible.

How do I use ABS?

Depress and hold the pedal. DO NOT PUMP THE BRAKES (that prevents the system from working). Just hold the brake pedal down and let the ABS work for you. You may feel the brake pedal vibrate, or you may notice some noise, but this is normal as the system works for you.

Should I drive an ABS equipped vehicle differently than I would drive a vehicle with conventional brakes?

Most of the time, under normal driving circumstances, there is no difference, and you should always drive with the same caution and care. It is important to realize that ABS only makes a difference when it is activated—when you have to brake hard—and that would only be when the computer senses that a wheel is approaching lock up. When ABS activates keep steady pressure on the brake pedal and then let the ABS work for you. Don't pump the brakes or try to find the threshold. Simply hold the brake pedal down and steer if necessary to avoid an obstacle.

Is ABS always active?

ABS is always available, but not always activated. ABS is activated only when the brake pedal is applied and the computer detects an impending wheel lock condition.

Can older cars be retrofitted with ABS?

No! The brake system is one of the most important features on any passenger vehicle. Several products, which tap into the master cylinder and/or brake system performance, are being sold in the aftermarket. Some of these products imply performance similar to new vehicle anti-lock brake systems.

However, contrary to their claims, add-on systems, which deplete fluid from the master cylinder on brake apply may actually increase a vehicle's stopping distance. This may cause the vehicle to fail to comply with Federal brake standards.

Does ABS always activate at the same speed?

No, the system operates when the computer detects wheel lockup, at any speed above 8 mph.

Will ABS wear out a vehicle's brakes sooner?

A properly maintained brake system will be unaffected by ABS operation under typical driving conditions.

Are there different types of ABS?

Yes, there are rear wheel anti-lock systems (RWAL) used on some trucks and four-wheel ABS available on cars and trucks.

Do Federal Safety Standards mandate ABS?

No. Federal standards establish minimum braking performance requirements that all vehicles must meet, but do not specify how they should be met. It should be noted that even a vehicle with failed ABS meets the Federal safety standard for stopping distances.

Will a tire size change affect ABS?

Use of tires other than original equipment may affect ABS performance. Owners should consult and follow the recommendations contained in the vehicle owner's manual regarding replacement tire size. *Note: ABS will work with original equipment spare tire or tire chains. However, performance is reduced.*

Do insurance companies give a discount for ABS?

Yes, many insurance companies give discounts that range from 5% to 10%. In the states of New York and Florida all insurance companies are required to give an ABS discount of 5% on certain coverages such as bodily injury, property damage, collision, and personal injury protection. In other states the discount varies from insurance company to insurance company. When buying auto insurance, always ask your insurance agent if his/her company gives a discount for vehicles equipped with anti-lock brakes.



IMPORTANT DRIVING SAFETY TIPS



- A. Always maintain a safe following distance.** ABS does not allow you to stop on a dime. (Generally a 2-second following distance is considered safe in ideal conditions.) Watch the vehicle in front of you pass a fixed marker (such as a sign). Count seconds—one-thousand-one, one-thousand-two-until your front bumper reaches the marker. If you do not count out two seconds, then you are too close to the vehicle in front of you. Also, if the roads are wet or icy, or visibility is poor, you should increase your following distance.
- B. Always drive carefully—** especially on slippery surfaces. ABS cannot create friction between the tires and the road surface, it can only give the driver the maximum advantage of the existing adhesion. If the vehicle is traveling on a surface with no adhesion, the best ABS in the world cannot provide a shorter stopping distance or good steering.
- C. It is a good idea to practice an ABS activated stop** and get the feel of the brake pedal. However, please make sure it's at a safe time with no obstacles in your path. And you only really need to try it once or twice to know what happens.

STABILITY ENHANCEMENT SYSTEMS (StabiliTrak)

Stability enhancement system (StabiliTrak) assists the driver with directional control of the vehicle in difficult driving conditions. Each time the vehicle is started, the StabiliTrak system is fully ON. StabiliTrak can be controlled by a StabiliTrak button on the instrument panel. The

condition of the system is displayed by an instrument panel StabiliTrak indicator light and Driver Information Center (DIC) messages. See your owner's manual for additional information about the operation of StabiliTrak.



Fleet and Commercial

For Information 1-800-FLEET-OP (353-3867)
www.gmfleet.com