

CHRIS KING[®]
PRECISION COMPONENTS

ISO Hub Manual

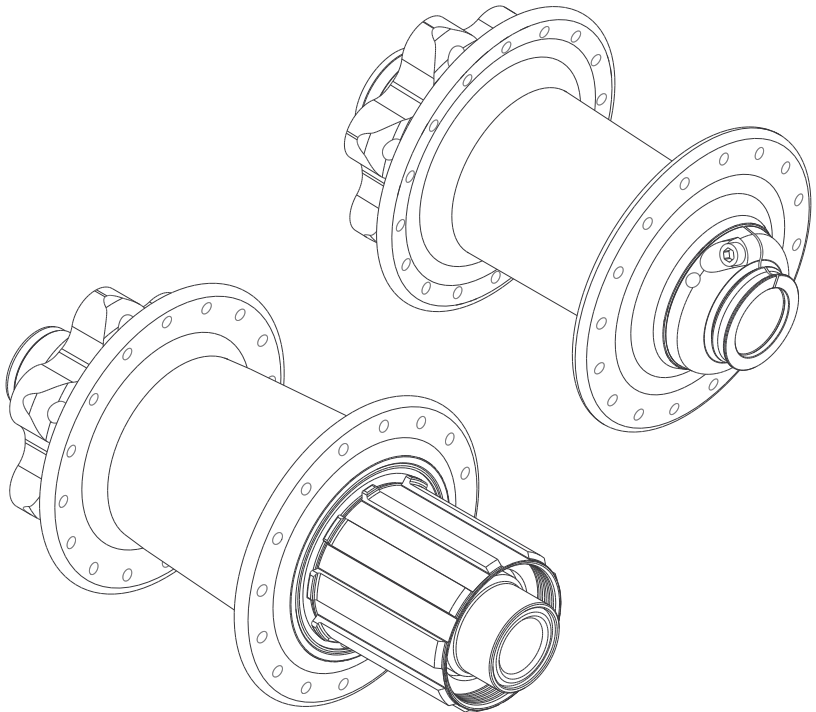

5 year warranty
register online
chrisking.com/warranty

serial number

Contents

Introduction and Cautions	1
Preparation	
Wheel building.....	1
Frame preparation.....	2
Installation/Removal of the brake rotor.....	2
Hub identification and Attachment Type.....	2
One Piece Axle.....	2
FunBolts.....	2
QR Adaptors.....	2
Thru Axle.....	2
Two Piece Axle.....	3
Set Up.....	3
Break-in.....	4
Maintenance	
Maintenance schedule.....	4
Notes on RingDrive maintenance.....	5
Lubrication: Normal/Cold/Wet conditions, In a pinch.....	5
Disassembly/Reassembly/Adjustment of two piece axle on front ISO hub.....	6
Disassembly/Reassembly/Adjustment of one piece axle on front ISO hub.....	7
Disassembly/Reassembly/Adjustment/Conversion of - Lefty SuperMax and Lefty LD front ISO Hub	8
Disassembly/Reassembly/Adjustment of one piece axle on rear ISO hub.....	10
ISO Single Speed rear hub.....	12
Cogs/Chain/Chainline.....	12
Cog Installation/Removal.....	12
Disassembly/Reassembly/Adjustment of two piece axle on rear ISO hub....	13
The RingDrive: Inspection/Basic Maintenance/Service.....	15
In a pinch.....	16
Reinstallation of the driveshell assembly.....	16
Service of the bearings.....	17
Universal Disc Brake Rotor Adaptors: Installation/Removal.....	18
Hub specifications and wheel building information	20 & 21
Additional support	14 & 19
Warranty and contact information	back cover

Congratulations

You have just purchased the finest hubs available. With proper care and maintenance you will enjoy many years of the legendary performance you have come to expect from all Chris King Precision Components. This manual is designed to give you the information needed for the setup, use, and basic maintenance of your new hubs.

As with all Chris King Precision Components, our hubs are superbly designed and manufactured, responsibly light, and meticulously finished. Our hubs feature our patented RingDrive engagement system spinning around a 19.5mm aluminum axle on four sets of precision bearings, all of which are manufactured in-house. This combination, housed in an elegant aluminum shell, offers the solid and reliable performance demanded by serious cyclists. Like all of our components, our ISO hubs are user serviceable.

Cautions

Do not use thread-locking compound on any part of your hub(s). The aluminum driveshells of the rear hubs are softer than the steel shells, and we recommend using "spidered"-style cassettes when possible. Avoid using individual cog-style cog sets with aluminum driveshells. **We recommend using our aluminum or Ti cog lock rings when installing 9 and 10 speed drivetrains for increased thread purchase.**

Chris King hubs feature adjustable bearing preload. The bearings should be kept in proper adjustment for optimum product performance. Do not allow the adjustment to become loose, as this may cause a loss of performance and could lead to damage to the hubs.

Chris King hubs with two piece axles are designed to be used in conjunction with quick-release skewers. It is recommended that the skewer develop a minimum of 1100 lbs. of clamping force when set. For best performance, use skewers with steel shafts. Titanium shafted skewers are not recommended.

Preparation

Wheel building

Hub dimensions for wheel building are available on pages 20 and 21.

Chris King ISO hubs are designed to work with 13, 14 or 15 gauge spokes. Disc brake wheels must be laced using at least a 2 cross lacing pattern. As the torque generated by driving the cassette requires crossed spokes, so does the additional torque on the non-drive side flange generated by the braking action. Radial lacing your ISO hubs is considered outside of the intended use and will void your warranty. We will not be responsible for damaged or destroyed hubs, any consequential damages, or any resulting labor costs due to radial lacing your ISO hub.

ISO Lefty® LD and ISO Lefty® SuperMax wheel builds will require the use of a truing stand Lefty® hub adapter tool such as Park's® TS-TA or Cannondale's® Lefty® wheel-truing dummy axle.

Proper wheel building technique is essential in creating a strong wheel. Wheel building is a skill that requires proper training and specialized tools and should be done by a trained professional. The spoke tension on each side of the wheel should be as uniform as possible. Tension should not exceed 120kgf (1200N).

The hub(s) come pre-adjusted from the factory. The adjustment has been made anticipating spoke tension and skewer compression. Because of variations in wheel-building practices, a minor adjustment should be performed upon completion of the wheel build. See the appropriate "**Adjustment**" pgs. 6 - 14 and check the hub before using.

Frame Preparation

Check frame and fork dropouts to ensure that they are parallel to each other. Use an appropriate tool made by a reputable bicycle tool manufacturer. Non-parallel dropouts may damage or compromise the performance of your hub.

Installation and Removal of the rotor

Please follow your brake manufacturer's specifications for rotor installation and rotor bolt torque specifications.

Hub Identification and Attachment Type

One Piece Axle (see Figure 1)

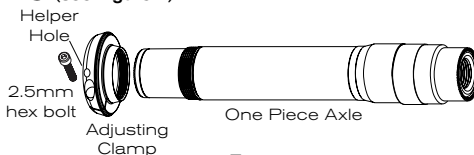
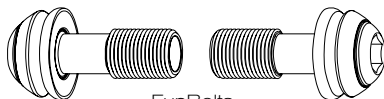

Figure 1

The one piece axle uses an adjusting clamp to adjust the hub bearing preload. Hubs that are factory assembled with the one piece axle include: ISO 135/142/150/157mm rear, ISO Single Speed rear, ISO 15/20/24mm front, and Universal Disc 145/160mm rear. **One piece axle disassembly, reassembly and adjustment procedures can be found on pages 7 - 12.**

• FunBolts (see Figure 2)

Chris King FunBolts are hollow, stainless steel bolts that can be used as a retention device in conjunction with standard 10mm slot-width rear dropouts with the 135/145/160mm one piece rear axle. FunBolts should be torqued to **25 foot-pounds** using an **8mm** hex wrench.



FunBolts

Figure 2



QR Adaptors

Figure 3

• QR Adaptors (see Figure 3)

Chris King QR Adaptors allow for the use of a skewer-type retention device with the 135/145/160mm one piece threaded rear axle. The adaptors are threaded into both ends of the axle using a **5mm** hex wrench.

• Thru Axle

ISO 15/20mm front and ISO 135 x 10mm, 135 x 12mm, 142 x 12mm, 150 x 10mm, 150 x 12mm, and 157 x 12mm rear hubs are attached to the frame with a thru axle. The thru axle is supplied by the fork or frame manufacturer.

Two Piece Axle (see Figure 3)

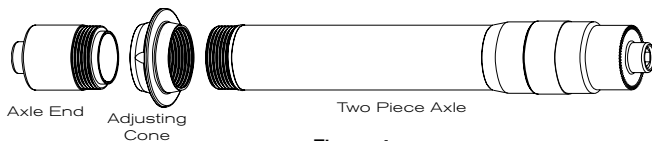

Figure 4

The two piece axle uses an adjusting cone to adjust bearing preload and an axle end cone to lock the preload adjustment. Hubs that are factory assembled with the two piece axle include: ISO front, Universal Disc front, and Universal Disc 140mm rear. **Two piece axle disassembly, reassembly and adjustment procedures can be found on pages 6, 10 and 11.** The two piece axle design (see Fig. 4) is designed for a skewer-type retention device and must not be modified or altered to accept any type of bolt-on retention device.

One piece and two piece axles are interchangeable on many ISO rear hubs. For details on axle conversions, please refer to the hub specifications table on pages 20 and 21, call our Technical Services Department at 800.523.6008, or check out our web site for tech info and videos: www.chrinking.com

Front and rear hubs can be converted to fit many different axle standards and frame mounting configurations. See the Hub Specifications table on pages 20 and 21 for axle conversion options.

3

Set-Up

• ISO SD & LD Front

- Chris King front ISO hubs are designed to work with 100mm and 110mm fork drop out spacing. Do not attempt to use your hub with any other dropout spacing. The two piece axle design (see Fig. 4) is designed for a skewer-type retention device and must not be modified or altered to accept any type of bolt-on retention device.

Chris King SD (small diameter) hub shells are compatible with both a standard QR and a 15mm through axle. Our LD (large diameter) hubs are hubs are designed to be used in conjunction with 15mm and 20mm thru-axes only. The thru axle is supplied by the fork manufacturer.

• ISO Lefty® SuperMax, and Lefty® LD Front

Chris King Lefty® SuperMax hubs are designed to be used in conjunction with Cannondale's ® Lefty® SuperMax suspension systems only.

Chris King Lefty® LD hubs are compatible with non-Supermax Lefty® suspension systems when using our 1mm Disc Spacer, and SuperMax Lefty® suspension systems from Cannondale® with the use of our 1mm Disc Spacer and the correct disc brake caliper adapter.

• ISO 135mm Rear

Chris King rear ISO 135mm hubs are designed to work with 135mm frame spacing. Do not attempt to use your hub with any other dropout spacing. The one piece axle design (see Fig. 1, pg. 2) can be used with Chris King FunBolts or with our QR adaptors, which

allow for the use of a skewer-type retention device. Additionally, 135 x 10mm and 135 x 12mm hubs are designed to be used in conjunction with 10mm and 12mm thru-axles only. The thru axle is supplied by the bicycle frame manufacturer or through an aftermarket supplier. Total axle width is 135mm.

The earlier two piece axle (see Fig. 4) is designed for exclusive use with a skewer-type retention device and the hub can only be used with FunBolts by replacing the two piece axle with the one piece axle. Do not modify or alter two piece axle systems to accept thru-bolt retention devices.

- **ISO 142mm Rear**

Chris King 142 x 12mm hubs are designed to be used in conjunction with 12mm thru-axles only. The thru axle is supplied by the bicycle frame manufacturer. Total axle width is 142mm.

- **ISO 150mm Rear**

Chris King 150 x 10mm and 150 x 12mm hubs are designed to be used in conjunction with 10mm and 12mm thru-axles only. The thru axle is supplied by the bicycle frame manufacturer. Total axle width is 150mm.

- **ISO 157mm Rear**

Chris King 157 x 12mm hubs are designed to be used in conjunction with 12mm thru-axles only. The thru axle is supplied by the bicycle frame manufacturer. Total axle width is 157mm

- **ISO Single Speed Rear**

ISO Single Speed rear hub and cog set-up information can be found on pages 9 and 10.

The grease in your hub will provide optimum performance between 30°-110°F. The bearings and RingDrive engagement mechanism come lubricated with a specially formulated low-shear grease. To maintain maximum performance in extreme temperatures see appropriate section under "**Lubrication**", pg. 5.

Break-In

Once your new hub is placed in service, some settling may occur. Check adjustment by attaching wheel into dropouts. Ride for 5-10 minutes, check for play or binding, and readjust if necessary. Recheck after the first 1-5 hours of riding. Check cog lock ring on rear hubs after the first 20 hours of use, and tighten if necessary. Continue monitoring for the first 60 hours of use.

During the first 60 hours of use, above average amounts of drag may be noticed. This is normal as the seals break in, and will soon diminish. If this causes chain sag while back-pedaling, increase the B-tension (cage tension) on the rear derailleur.

The bearing grease is intentionally overpacked and excess grease may seep from the bearing seals during the break-in period.

Maintenance

Maintenance schedule

Chris King ISO Hubs are designed to provide long life and high performance. Beyond an occasional adjustment, the only maintenance necessary is cleaning, lubricating the RingDrive (see "**The RingDrive**", pg. 15), and re-lubricating the bearings (see "**Service of the bearings**", pg. 17). Riding conditions will determine how often to maintain your hubs. As a beginning guideline, your hubs should be maintained every 6-12 months in normal and dry conditions and every 3 months in wet or muddy conditions.

The bearings in your new Chris King hubs are of the highest quality. However, all bearings will settle and eventually wear with use. Since looseness or “play” in the bearing assembly can develop as a result of wear, Chris King hubs have been designed with an adjustable bearing preload mechanism and any normal play can be eliminated (see the appropriate “**Adjustment**” section, pgs. 6 - 14). ***Do not ride hub without the proper preload adjustment**

Notes on RingDrive™ maintenance

Normal preventative maintenance of the RingDrive is simple and can be performed using basic tools (see “**The RingDrive**”, pg. 15). In many cases, a minor cleaning and reapplication of lubricant is all that may be necessary. Judging when to perform this basic maintenance is determined by riding style and conditions. As a guideline, your hubs should be maintained every 6-12 months in normal and dry conditions and every 3 months in wet or muddy conditions.

Annually or if bearing and freewheel drag is noticed or foreign debris is detected in the grease and/or the grease looks hard or dry, a complete servicing (removal and cleaning) of the RingDrive should be performed. Complete service includes the removal of the RingDrive engagement mechanism and requires the use of our Hub Service Tool. See any authorized Chris King dealer for complete service or you may purchase a Hub Service Tool Kit from your dealer or directly from Chris King Precision Components. **Chris King Precision Components provides overhaul services at reasonable rates. Contact the Customer Service hotline at 800-523-6008 for details.**

Lubrication

Normal conditions

In normal riding conditions (32°-110°F), our RingDrive grease is recommended for the bearings and the RingDrive. **Do not substitute other brands of grease, as they may cause premature wear and/or be too sticky for the helix of the RingDrive inhibiting proper engagement.**

Cold conditions

To ensure proper engagement in sub-freezing conditions, first be sure that there is no water or moisture inside the hubshell. The hub may require an overhaul to ensure that the hub interior is completely water-free. Then mix the grease in the RingDrive area, especially on the helical splines of the driveshell, with 5-10 drops of Tri-flow. If you expect to be riding in temperatures that are consistently at or below freezing replace all internal lube with a quality 10w synthetic oil. **Do not over fill.** We recommend using a siliconal oil (Pedros® SynLube or Mobil 1®)

Wet conditions

Riding in wet conditions necessitates more frequent service. Often this is as simple as removing the axle and driveshell from the hub, removing any moisture from inside the hub shell, and applying more grease to the needle bearing. This should not replace periodic complete disassembly and maintenance, especially in extreme or prolonged wet conditions.

Since it is nearly impossible to seal a hub from water and still have it spin freely, we have designed our hubs to be able to operate normally with some water intrusion. Although the bearings are stainless steel and will resist water induced corrosion, the lubricant will eventually deteriorate, leading to premature bearing wear and possible failure. High-pressure spray washing, transporting or riding the bicycle in the rain, or submersion in water while riding can all lead to lubricant contamination

by water. Be aware of these situations and service more frequently when they occur.

In a pinch...

If Chris King RingDrive lube is not available, a quality 10w synthetic oil may be substituted. **Do not substitute other brands of grease, as they may be too sticky for the helix of the RingDrive.** Running the hub on oil will cause the RingDrive to be more audible, yet functionally no different. Since this is a lighter lube than our RingDrive lube your hub needs to be serviced more often.

If you have any additional questions, please call our Technical Services Department at 800.523.6008, or check out our web site for tech info and videos: www.chrisking.com

Disassembly of two piece axle on front ISO hub (see Figure 5)

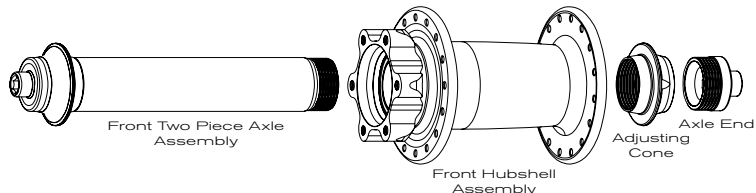

Figure 5

1. Insert 5 mm hex wrenches into both ends of axle assembly. ***Pro Tip: Use a bench vice to hold one of the 5mm hex wrenches.**
2. Hold left hand stationary and turn right hand counterclockwise 1/4 turn until assembly is loose.
3. Loosen and unscrew adjusting cone and axle end until they are free from main axle.
4. Slide out main axle.
5. Both hub shell bearing assemblies can now be accessed.

For bearing service information see **“Service of the bearings”**, pg. 17.

Further disassembly requires specialized tools. These come individually or in the Chris King Hub Service Tool Kit, which is available at any authorized Chris King dealer, or directly from Chris King Precision Components.

Reassembly of two piece axle on front ISO hub (see Figure 5)

1. Lightly grease threads on axle, adjusting cone and axle end. Apply two drops of Tri-flow™ or a quality 10w synthetic oil to axle O-ring.
2. Insert main axle into hub shell.
3. If axle end and adjusting cone are assembled as one unit, disassemble by threading axle end out of adjusting cone.
4. Thread adjusting cone onto the protruding threads of main axle.
5. Lightly snug adjusting cone up to bearing.
6. Thread axle end into adjusting cone until it stops.
7. Proceed to **“Adjustment of two piece axle on front ISO hub”**, below.

Adjustment of two piece axle on front ISO hub (see Figure 5)

1. Insert 5 mm hex wrenches into both ends of axle assembly. ***Pro Tip: Use a bench vice to hold one of the 5mm hex wrenches**
2. Hold left hand stationary and turn right hand counterclockwise 1/4 turn until assembly is loose.
3. Hold hex wrenches stationary and adjust bearing preload with adjusting cone.
4. Advance adjusting cone until it just contacts bearing, then back off approximately 1/16 turn (this allows for axle compression while under skewer clamp pressure).
5. Once preload is set, tighten axle assembly to **110 inch-pounds**.
6. Double check adjustment by clamping wheel into fork with quick-release. Check for play or binding, and readjust if needed.

Disassembly of one piece axle on ISO front hub (see Figure 6)

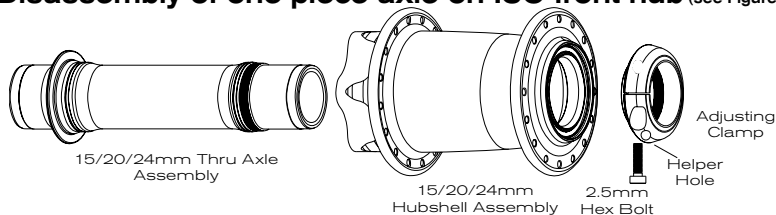

Figure 6

1. Remove the hub from the fork. Remove the disc brake rotor.
 2. Insert a **2.5mm** hex wrench into adjusting clamp hex bolt, and loosen.
 3. With adjusting clamp facing towards you, hold opposite end of axle stationary, and rotate clamp in a counter clockwise direction to unscrew it from the thru-axle. If adjusting clamp is difficult to remove, insert a 2.5mm hex key into "helper hole" on adjusting clamp adjacent to 2.5mm hex bolt. Use the hex key as a lever to unscrew adjusting clamp. **Note: 15mm SD hubs feature a steel axle end cap that will pop off of axle end as adjusting clamp is unthreaded from axle.**
 4. Remove the axle from the hubshell.
- For bearing service information see "**Service of the bearings**", pg. 17.

Reassembly of one piece axle on ISO front hub (see Figure 6)

1. Lightly grease threads on adjusting clamp. Apply two drops of Tri-flow™ to axle O-ring
2. Insert the axle into the hubshell from the disc mount side.
3. Thread the adjusting clamp onto the protruding threads of the axle.
4. Snug the adjusting clamp up to the bearing. **Note: 15mm SD hubs feature a steel axle end cap that must be hand-pressed back onto the end of the axle.**
5. Proceed to "Adjustment of one piece axle on ISO front hub", below.

Adjustment of one piece axle on ISO front hub (see Figure 6)

The one piece axle features an adjusting clamp which minimizes over tightening or over pre-loading of the bearings. Adjustment may be accomplished while the hub is attached to the fork.

1. Loosen the adjusting clamp hex bolt using a **2.5mm** hex wrench.

2. Hand tighten the adjusting clamp onto the axle until it stops against the bearing.
3. Once the adjusting clamp is in position, use a **2.5mm** hex wrench to tighten the adjusting clamp hex bolt to **10 inch-pounds**.
4. Check for play or binding and readjust if needed.

If you have any additional questions, please contact our Technical Service Department at 800-523-6008, or check out our website for tech info and videos: www.chrisking.com

ISO Lefty® LD and ISO Lefty® SuperMax

ISO Lefty® SuperMax
Hubshell Assembly
Serial # Prefix - 2210

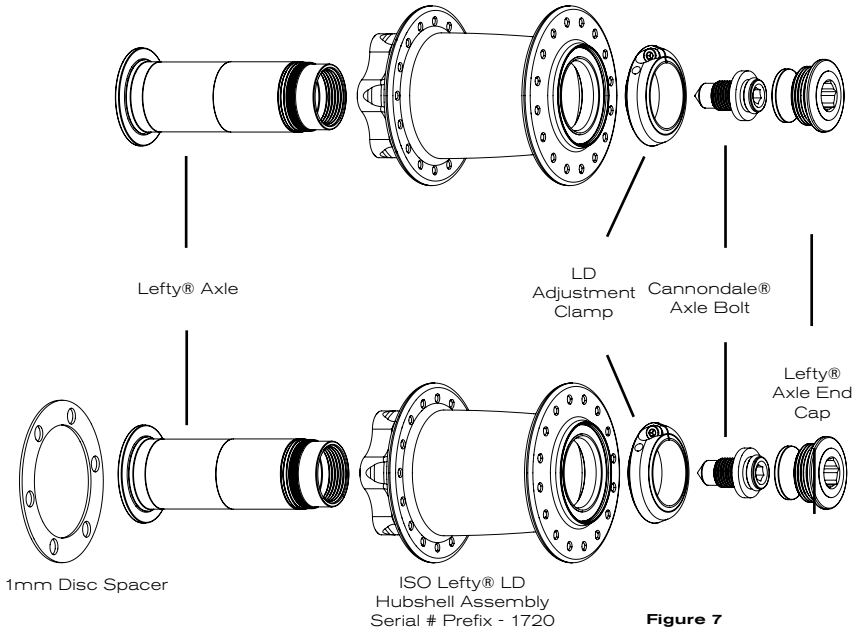

IMPORTANT

Please refer to Cannondale's® Lefty® instruction manual for wheel installation and removal information, http://www.Cannondale.com/manual_headshok/. Chris King's ISO Lefty® LD Front Hub and ISO Lefty® SuperMax Front Hub utilize the same self-extracting hub removal system found in Cannondale® Lefty® and Lefty® SuperMax Hubs. *The ISO Lefty® LD can be used with the SuperMax provided the correct disc brake adapter is used. Please see http://www.Cannondale.com/manual_headshok/ for more details.

Converting ISO LD Front Hub to a ISO Lefty® LD Front Hub

Chris King Gen. 2 ISO LD Front Hubs are easily converted to work with Lefty® forks by using our ISO Lefty® Upgrade Kit. When converting an ISO LD Front Hub to an ISO Lefty® LD Front Hub make sure that your LD Front Hub is designated with a 1720 serial number prefix, this number is found on the hubshell. LD Front Hubs with a 1710 designation are not compatible with an ISO Lefty® LD Front Hub Conversion. Follow the disassembly procedure on pg. 7 to remove the standard ISO one piece axle and use the reassembly procedure in this addendum to install your ISO Lefty® LD Front Hub axle.

Disassembly of ISO Lefty® LD Front Hub and ISO Lefty®

SuperMax Front Hub (see Figure 7)

1. Remove hub from the fork prior to disassembly. The ISO Lefty® LD Front Hub and ISO Lefty® SuperMax Front Hubs are designed to be self-extracting. Insert a 5mm hex wrench through the Lefty® axle end cap and turn in a counter-clockwise motion. The Cannondale® axle bolt will push against the Lefty® axle end cap and pull the hub off of the fork.

*Removal of axle from front hub is only necessary for bearing service.

2. Using an 10mm hex wrench remove the Lefty® axle end cap. NOTE - The Lefty® axle end cap is left-hand thread (turn counter-clockwise to tighten and clockwise to loosen). Take care not to over tighten the Lefty® axle cap. *The Cannondale® axle bolt is designed to nest in the axle cap and should come off with the Lefty® axle end cap.

3. If not removed along with the Lefty® axle end cap, remove the Cannondale® axle bolt from the axle.

4. Remove the disc brake rotor. *For ISO Lefty® LD Front Hubs be sure to also remove the Chris King 1mm disc spacer.

5. Insert a 2.5mm hex wrench into the adjusting clamp hex bolt, and loosen.

6. With the adjusting clamp facing towards you, hold opposite end of axle stationary with the Spline Drive Hub Tool. For more information on this tool visit <http://chrisking.com/shop>. Rotate the clamp in a counter-clockwise direction to unscrew it from the Lefty® axle. If adjusting clamp is difficult to remove, insert a 2.5mm hex wrench into "helper hole" on the adjusting clamp adjacent to 2.5mm hex bolt. Use the hex wrench as a lever to unscrew the adjusting clamp.

7. Remove the axle from the hubshell.

For bearing service information see "Service of the bearings" on pg. 17 of the Chris King ISO Manual. Further disassembly requires specialized tools. These tools come individually or in the Chris King Hub Service Tool Kit, available from any authorized Chris King dealer, or directly from Chris King Precision Components, visit our website

http://chrisking.com/tech/tech_hubs for specific ISO Lefty® LD and ISO Lefty® SuperMax service information.

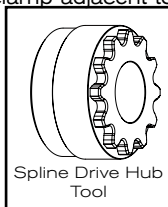

Reassembly of ISO Lefty® LD Front Hub and ISO Lefty®

SuperMax Front Hub (see Figure 7)

1. Lightly grease threads on adjusting clamp. Apply two drops of Tri-Flow™ to

axle o-ring.

2. Insert the axle into the hubshell from the disc mount side.
3. Thread the adjusting clamp onto the threaded end of the axle.
4. Once the adjusting clamp is in position, use a 2.5mm hex wrench to tighten the adjusting clamp hex bolt to 1.13Nm (10 inch-pounds). *Use the Spline Drive Hub Tool to hold the axle steady. Bearing adjustment may be accomplished while the hub is attached to the fork.
5. Check for play or binding and readjust if needed. *See pg. 7 for more information on the adjustment of one piece axle equipped ISO Front Hubs.
6. Apply two drops of Tri-Flow™ to the o-ring on the Cannondale® Axle Bolt.
7. Insert the Cannondale® Axle Bolt into the axle end cap.
8. Two drops of Vibra-Tite® VC-3 have been added to the threads of the axle end cap. This is applied at the factory and is good for multiple uses. If resistance is not apparent when threading on the axle end cap reapply two drops of Vibra-Tite® VC-3 Threadmate to the threads. As a substitute, a small drop of Loctite 242 or 243 may be used.
9. Using the Spline Drive Hub Tool to hold the axle and a 10mm hex wrench, install the Lefty® axle end cap. The Lefty® axle end cap is left-hand threaded. Tighten the Lefty® axle end cap to 12.0Nm, take care not to over tighten.
10. Install the disc brake rotor. When using an ISO Lefty® LD Front Hub be sure to install the 1mm disc spacer between the disc rotor and the hub shell as specified by Cannondale®.
11. Slide the hub onto the Lefty® fork axle. Tightening the Lefty® axle bolt will seat the hub on the Lefty® fork axle. Use a torque wrench to tighten the Cannondale® axle bolt to 15.0Nm.

Disassembly of one piece axle on rear ISO hub (see Figure 8)

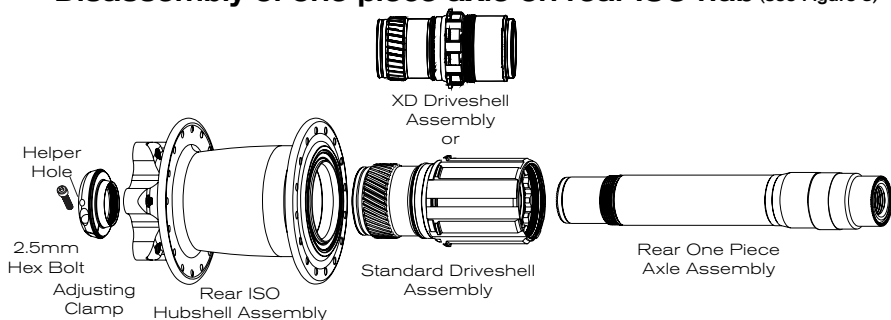

Figure 8

1. Remove cassette lock ring and cassette using a chain whip and HG™ cassette lock ring removal tool.

*If using an XD Driveshell the End Cap is removed along with the cassette use a small punch or small flat head screw driver to gently tap the Driveshell

End Cap out of the cassette.

2. With adjusting clamp facing towards you, hold opposite end of axle stationary, and rotate clamp in a counter clockwise direction to unscrew it from the thru-axle. If adjusting clamp is difficult to remove, insert a 2.5mm hex key into “helper hole” on adjusting clamp adjacent to 2.5mm hex bolt. Use the hex key as a lever to unscrew adjusting clamp. **Note: 142/157mm axles feature a steel axle end cap that will pop off of axle end as adjusting clamp is pulled from axle.**
3. Remove axle by pulling on drive side end of axle.
4. Hold hub or wheel in one hand and pull driveshell with other.
5. Hub shell bearings, RingDrive internals and driveshell bearing assemblies can now be accessed.

For RingDrive inspection and maintenance information, see “**The RingDrive**”, pg. 15.

For bearing service information see “**Service of the bearings**”, pg. 17

Further disassembly requires specialized tools. These come individually or in the Chris King Hub Service Tool Kit, which is available at any authorized Chris King dealer, or directly from Chris King Precision Components.

Reassembly of one piece axle on rear ISO hub (see Figure 8)

1. Lightly grease threads on adjusting clamp. Apply two drops of Tri-flow™ to axle O-ring. If using QR adaptors or FunBolts, apply anti-seize to threads before threading them into the axle.
2. Apply two drops of Tri-flow™ to driveshell O-ring. Insert driveshell into the hub shell; turn in a clockwise motion while letting it pull itself in. A distinctive click sound will indicate that the driveshell is firmly seated.
3. Insert finger from the non-drive side to push spring retainer to ensure Driveshell is seated correctly
4. Insert main axle, small end first into driveshell. Continue until axle is through the hub and large end is firmly seated in driveshell.
5. Thread adjusting clamp onto the protruding threads of axle.
6. Snug the adjusting clamp up to the bearing. **Note: 142mm and 157mm axles feature a steel axle end cap that must be hand-pressed back onto the end of the axle.**
7. Proceed to “**Adjustment of one piece axle on rear ISO hub**”, pg. 10.

Note: To improve performance, the axles have been precisely matched with the needle bearings in the driveshell. Be sure to combine only like numbered parts, (e.g., #3 axle with #3 needle bearing race).

Adjustment of one piece axle on rear ISO hub (see Figure 8)

The one piece rear axle assembly features an adjusting clamp that minimizes over tightening or over preloading of the bearings. Adjustment may be accomplished while axle is attached to bicycle frame or in a truing stand.

1. Loosen the adjusting clamp hex bolt using a **2.5mm** hex wrench.
2. Hand tighten the adjusting clamp onto the axle until it stops against the bearing. If adjusting clamp is difficult to move, insert a 2.5mm hex wrench into “helper hole”

on adjusting clamp adjacent to 2.5mm hex bolt. Use the hex key as a lever to turn adjusting clamp.

3. Once the adjusting clamp is in position, use a **2.5mm** hex wrench to tighten the adjusting clamp hex bolt to **10 inch-pounds**.
4. Check for play or binding and readjust if needed.

Note: Correct adjustment of the rear hub is necessary for proper engagement of the RingDrive. If the hub is run loose, the RingDrive may not engage properly and could lead to permanent damage of the internal parts. ***Do not ride hub without the proper preload adjustment**

ISO Single Speed rear hubs (see Figure 9)

The ISO Single Speed rear hub uses our Single Speed one piece axle design. For disassembly, reassembly and adjustment information, follow the one piece axle instructions on pages on pages 10 and 11 of this manual.

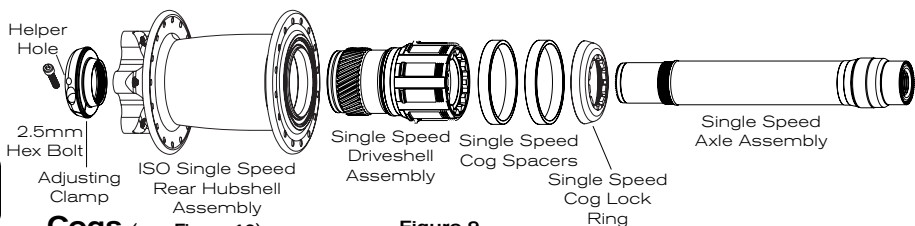

Cogs (see Figure 10)

Figure 9

Chris King Single Speed hubs use a cassette-style cog mounting system. Special splines and lock rings have been designed to accept our premium quality stainless steel cogs. They are available in sizes from 12t to 20t. Cogs can easily be removed and changed using standard cassette tools.

Chain

Chris King cogs are designed to be used with an **8-speed or 3/32" chain only**.

Chain line

Setting the single speed cog to the proper chain line is essential to achieving the best performance from a bicycle's drivetrain. Our Single Speed rear hub allows for center-to-cog chainlines of 45, 50 and 55mm. To determine the proper chainline on a single speed bicycle with 135mm rear dropout spacing, follow these instructions:

1. Determine the front chain ring position by measuring the distance from the exact middle of the bottom bracket shell to the front chainring.
2. Locate the middle point of the rear ISO Single Speed hub by measuring 67.5mm from the inside face of the rear dropout to the middle of the hub.
3. From that middle point, use the front chain ring position measurement found in step 1, and measure from the hub center out to the driveshell.
4. This is the point on the driveshell where the rear single speed cog should be



Figure 10

located to obtain the proper center-to-cog chainline.

5. Use the Single Speed Cog Spacers and Lock Ring that is included with the hub to secure the cog in the proper position. Proceed to **“Cog Installation”**, below.

Cog installation

1. Slide cog onto driveshell spline. Cogs are symmetrical, and can be installed either side out. Install Single Speed Cog Spacers, making sure cog is set at the proper chain line. To determine proper chain line, see **“Chain Line”** pages 12 and 13.
2. Lightly grease the threads on the lockring then thread Single Speed Cog Lock Ring onto driveshell.
3. Insert HG™ cassette lock ring tool into Cog Lock Ring, and tighten to **20 foot pounds**.

Cog removal

1. Using a chainwhip, hold cog stationary from counterclockwise rotation.
2. Insert HG™ cassette lock ring tool into Cog Lock Ring.
3. Loosen Cog Lock Ring by rotating it until it is free from driveshell.
4. Slide cog from spline.

Disassembly of two piece axle on rear ISO hub (see

Figure 11)

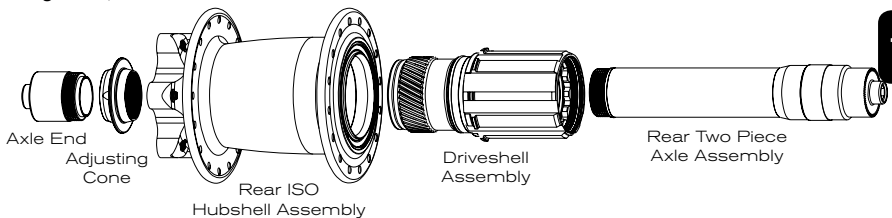

Figure 11

The following instructions assume that the driveshell is facing to the right:

1. Insert 5 mm hex wrenches into both ends of axle assembly. ***Pro Tip: Use a bench vice to hold one of the 5mm hex wrenches.**
2. Hold left hand stationary and turn right hand counterclockwise 1/4 turn until assembly is loose.
3. Loosen and unscrew adjusting cone and axle end until they are free from main axle.
4. Slide out main axle.
5. Remove axle by pulling on drive side end of axle.
6. Hold hub or wheel in one hand and pull driveshell out with the other.
7. Hub shell bearings, RingDrive engagement and driveshell bearing assemblies can now be accessed.

For RingDrive inspection and maintenance information, see **“The RingDrive”**, pg. 15. For

bearing service information see “**Service of the bearings**”, pg. 17.

Further disassembly requires specialized tools. These come individually or in the Chris King Hub Service Tool Kit, which is available at any authorized Chris King dealer, or directly from Chris King Precision Components.

Reassembly of two piece axle on rear ISO hub (see Figure 11)

1. Lightly grease threads on adjusting cone and axle end. Apply two drops of Tri-flow™ to axle O-ring.
2. Insert main axle through driveshell. The axle is properly seated when the threaded end appears through the bearing and the end is flush with the end of the hub shell.
3. If axle end and adjusting cone are assembled as one unit, disassemble by threading axle end out of adjusting cone.
4. Thread adjusting cone onto the protruding threads of main axle.
5. Thread axle end into adjusting cone until it stops.
6. Proceed to “**Adjustment of two piece axle on rear ISO hub**”, below.

Note: To improve performance, the axles have been precisely matched with the needle bearings in the driveshell. Be sure to combine only like numbered parts, (e.g., #3 axle with #3 needle bearing race).

Adjustment of two piece axle on rear ISO hub (see Figure 11)

The following instructions assume that the driveshell is facing to the right:

1. Insert 5 mm hex wrenches into both ends of the axle assembly. (See page 7 for more info)
2. Hold left hand stationary and turn right hand counterclockwise 1/4 turn until the assembly is loose.
3. Hold hex wrenches stationary and adjust bearing preload with the adjusting cone. You may use the hub cone adjusting tool if necessary.
4. Advance adjusting cone until it contacts bearing. The rear hub takes a slightly higher amount of preload than “no play”, since some settling may occur while riding.
5. Once preload is set, tighten axle end to **110 inch-pounds**.
6. Check adjustment by clamping wheel into frame with quick-release. Ride for 5-10 minutes, check for play or binding, and readjust as necessary. Double check adjustment after the first 5-10 miles of riding.

Note: Correct adjustment of the rear hub is necessary for proper engagement of the RingDrive. If the hub is run loose, the RingDrive may not engage properly and could lead to permanent damage of the internal parts. ***Do not ride hub without the proper preload adjustment**

Additional Support

Check our web site often for updated movies and technical information produced in an effort to help you, our customers, stay on your bike. **Visit:** http://chrisking.com/tech/tech_movies.html

Additional questions? Please email us at info@chrisking.com or call the Customer Service hotline at 800-523-6008.

The RingDrive™

Inspection

Having removed the axle and driveshell (as instructed in “**Disassembly...**” pgs 10 and 11), the RingDrive is accessible through the large side of the hub shell. Visually inspect the hub’s interior. Under normal conditions the grease should look moist and may have darkened slightly. A modest film should coat the moving parts.

As with the rest of the hub, the RingDrive is designed to operate with some water contamination. Water intrusion can usually be remedied with basic maintenance. However, if foreign debris is detectable in the grease and/or the grease looks hard or dry, then a complete removal and servicing of the RingDrive is necessary.

Basic maintenance

1. Take a clean, lint free rag and wipe any spent lubricant from inside the hub shell. Be careful not to drag any dirt or debris from outside the hub into the interior area.
2. Once the interior is clean in appearance, locate the helical splines of the drive ring about an inch inside the large bearing.
3. Using a toothbrush, pull the bristles across the helix in an outward direction. Work your way all the way around the inner circumference to remove any small particles that may be in the spline grooves.
4. Once completed, wipe the area directly in front of the helix to remove any debris. This method should be used to clean the helix on the driveshell as well. (If compressed air is available, blow across the helixes in line with the spline grooves to remove any debris).

With the interior wiped down and the helixes brushed clean, a fresh application of lubricant should be applied. The RingDrive is designed to work with our specially formulated low shear RingDrive grease. **Do not substitute other brands of grease, as they may be too sticky for the helix of the RingDrive.**

5. Lubricate by reopening a gap between the drive rings, and laying a bead of RingDrive grease on the teeth between them.
6. Apply a bead of RingDrive grease to helical splines on driveshell. Then apply a few drops of Tri-flow™ onto the helical splines and the o-ring of the driveshell.
7. **Before reinserting the driveshell into RingDrive area of the hub, the helical splines must be clean of any debris. *An optional Stainless Steel driveshell is available for riders who are experience above average wear.**
8. Proceed to “**Reinstallation of the driveshell assembly**”, pg. 16.

Service of the RingDrive™

In addition to the basic maintenance of the RingDrive, a complete removal and servicing may be necessary. Complete service requires our Hub Service Tool Kit and, as a basic guideline, should be performed at least once every 12 to 24 months. See any authorized Chris King dealer for complete service or you may purchase a Hub Service Tool Kit from your dealer or directly from Chris King Precision Components. **Chris King Precision Components provides overhaul services at reasonable rates. Contact the Customer Service hotline at 800-523-6008 for details.**

In a pinch...

If you need to perform a RingDrive service and don't have the Hub Service Tool Kit or cannot make it to a dealer, this method may be used for temporary results:

1. Remove the axle and driveshell to access the interior RingDrive area.
2. Push the drive ring with helical splines inward to open a gap, exposing the drive teeth and flush the interior with a light solvent-based spray lubricant (e.g., WD-40™) until the area appears clean. Blow off any remaining solvent until completely dry.
3. If contamination is still apparent, repeat flushing and blow completely dry. A complete service of both hub shell bearings should be performed at the same time. For bearing service information see **"Service of the bearings"**, pg. 17.
4. Finish by performing the **"Basic maintenance"**, pg. 15.
5. After assembly, carefully hand test hub for smooth operation of the bearings and consistent, positive engagement of the RingDrive. If performance is not improved to original quality, a complete RingDrive removal service must be performed.

Reinstallation of the driveshell assembly

1. Check the helical splines of the driveshell for any particles or debris before proceeding; **the driveshell must be clean before installing.**
2. Apply several drops of Tri-Flow™ on the helical spline, O-ring, and tapered diameter directly adjacent the O-ring. Apply a bead of RingDrive lube to the helical splines.
3. Insert driveshell into hub shell, slowly. As the driveshell enters the RingDrive area, it will want to mesh the helical splines of the drive ring. As it begins to mesh, a slight clockwise turning motion of the driveshell will help pull it into the hub shell. Continue twisting as the driveshell pulls itself into the hub shell. At the bottom of its inward movement, an audible "click" or "pop" sound indicates that it has found home and is fully seated. The "click" or "pop" is the spring retainer popping onto the driveshell and the driveshell seating on the bearing, indicating the driveshell is fully inserted. Some pushing pressure on the driveshell may be necessary to pop the spring retainer onto the end of the driveshell. You can check to make sure the driveshell is properly seated by checking with your fingers from the non-drive side of the hubshell.

Note: During removal of the driveshell unit the spring retainer plate can become off-centered. Be sure that the spring retainer is properly centered against the back of the

spring area before reinstalling the driveshell. Make sure the o-ring is correctly seated.

4. Test engagement by spinning driveshell in both directions. If it does not engage, remove driveshell, check cleanliness and reinsert. Retest.
5. The hub is now ready to have the axle installed.

Service of the bearings

(see figure 11)

Chris King sealed bearings have removable snap rings that hold the rubber seals in place.

1. Carefully, using a small screwdriver, pick, or penknife, remove the snap ring by inserting tool into split of snap ring. Gently work one end of the snap ring toward bearing center until it is out of its groove. Follow the ring around with the tool until the snap ring is completely dislodged.
2. Lift and remove exposed rubber seal to access the interior of the bearing.
3. Thoroughly flush the bearing with a light spray lubricant (e.g., WD-40™) and blow dry.

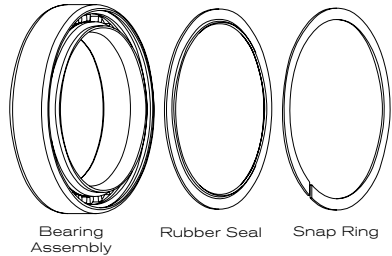

Figure 11

Note: Some solvents, synthetic lubricants, and greases with high-pressure additives may attack and damage seals and other nonmetallic materials. Minimize exposure to these substances and thoroughly dry hub after cleaning.

4. Wipe dirt and other contaminants from the seals and snap rings. Avoid cleaning the seals with solvent, which could cause deterioration.
5. Lay a bead of our RingDrive grease (see "**Lubrication**", pg. 6), filling the gap between the inner and outer races **3/4 the way around bearing. Do not overfill bearing with lube, as this may cause excess drag.** Rotate the inner race to work grease throughout the ball area.
6. Reinstall black rubber seal between inner and outer bearing race. If using the original seal, reinstall using the same orientation as when they were originally installed, as this will minimize drag.
7. Insert one edge of snap ring into groove of outer bearing race. Press along entire groove until snap ring is fully seated; a small gap should be visible between both ends of the snap ring.
8. Turn inner race of bearing by hand to test for binding. If bearings do not run smooth, repeat steps 1-8. Binding is often a result of improperly seated seals and/or snap rings.

Used snap rings and seals can be reinstalled unless warped, punctured, or otherwise damaged. If damaged, replacement seals and snap rings are available from any authorized Chris King dealers or directly from Chris King Precision Components.

Universal Disc Brake Rotor Adaptors

Brake rotor adaptors are used on Universal Disc front and rear hubs to accommodate ISO and other disc brake systems. These various adaptors are offered in different widths to correctly position disc brake rotors. Be sure to use the adaptor designed for your brake system. Do not attempt to modify your adaptor to work with rotors other than those for which they were designed. Mount the brake rotor according to manufacturer's instructions. Rotor mounting bolts should thread 8mm into the rotor adaptor and must not extend through the brake rotor adaptor or contact the hub.

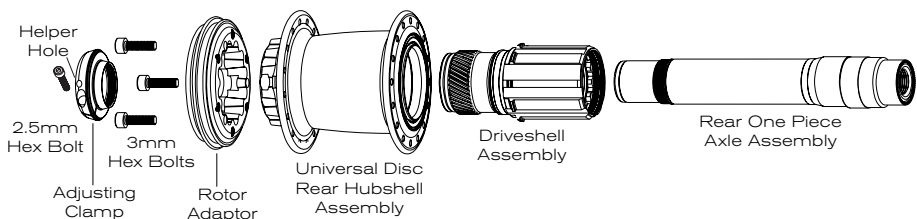

Figure 12

18

Installation of rotor adaptor (see Figure 12)

Before installation, thoroughly clean both the brake rotor adaptor and the splines on the hub shell. Any debris on the splines may not allow the rotor to run true, inhibiting the performance of the brake.

1. Apply a light amount of grease to rotor adaptor bolts. Do not use Loc-Tite™ or other sleeving compound to secure rotor adaptor.
2. Place the adaptor onto the splines. When snug, the adaptor should leave an even gap approximately the width of a piece of paper between the hub and the adaptor.
3. Insert the three bolts provided. In an alternating pattern, hand tighten adaptor bolts to pull adaptor down evenly.
4. Using a 3mm hex wrench, finish torque to 28 inch pounds. Do not over tighten.

Removal of rotor adaptor (see Figure 12)

1. Remove the disc brake rotor if it covers the three mounting bolts.
2. Remove the three adaptor mounting bolts using a 3mm hex wrench.
3. To remove the rotor adaptor from the tapered splines, pry between the adaptor and the hub using two opposing plastic tire levers (it should pop off easily). Do not use metal objects, such as screw drivers, to release the adaptor.

Additional Support

Check our web site often for updated movies and technical information produced in an effort to help you, our customers, stay on your bike.

Visit: http://chrisking.com/tech/tech_movies.html

Additional questions? Please email us at info@chrisking.com or call the Customer Service hotline at 800-523-6008.

ISO hub specifications and

Hub Type	Axle Type	Axle Width (mm)	Flange Diameter Drive Side & non-Drive Side (mm)	Center to Flange Drive Side (mm)
ISO QR SD front	two piece	100	57.4	31.3
ISO 15mm SD front	one piece	100	57.4	31.3
ISO 15mm LD front	one piece	100	57.4	31.6
ISO 20mm LD front	one piece	110	57.4	31.6
ISO 24mm front	one piece	110	57.4	26.5
ISO Lefty® SuperMax	one piece	Lefty	57.4	35.4
ISO Lefty® LD	one piece	Lefty	57.4	35.4
ISO 135 rear	one piece	135	57.4	20.1
ISO 135 x 10/12mm rear	one piece	135	57.4	20.1
ISO 142 x 12mm rear	one piece	142	57.4	20.1
ISO DH G1 150 x 10/12mm rear	one piece	150	57.4	25.0
ISO DH G2 150 x 10/12mm rear	one piece	150	57.4	28.5
ISO DH G2 157 x 12mm rear	one piece	157	57.4	28.5
ISO Single Speed rear	one piece	135	57.4	32.3
Universal Disc front	two piece	100	53.0	31.5
Universal Disc rear	one piece	135	53.0	21.0
Universal Disc Single Speed rear	one piece	135	53.0	32.0
Universal Disc rear tandem	two piece	140	53.0	23.5
Universal Disc rear tandem	one piece	145	53.0	26.0
Universal Disc rear tandem	one piece	160	53.0	33.7

G1: Generation One - Serial # begins with 1910

G2: Generation Two - Serial # begins with 2910

Frame Attachment Options

QR: Quick release only

TA: Thru-axle only

QR/FB: Quick release or FunBolts (FunBolts only compatible with rear one piece axle)

Small Parts Weights

* Add 48g if hub features a stainless steel driveshell

** Add 27g if hub features a XD Driveshell

** Add 5g if using 10mm thru axle

*** Weight includes 18t stainless steel cog (37g), single speed cog spacers (6g) single speed cog lock ring (4g) and FunBolts (42g)

**** Weight includes Cannondale® axle bolt (4g)

***** Weight includes 1mm disc spacer (3g), Cannondale® axle bolt (4g)

wheel building information

Center to Flange non-Drive Side (mm)	Frame Attachment Options	Available Spoke Hole Drilling	Upgrade & Conversion Options	Weight* (grams)	Weight* (grams)
				Steel	Ceramic
22.2	QR	28, 32, 36	4	166	163
22.2	15mm TA	28, 32, 36	4	164	161
23.3	15mm TA	28, 32, 36	5	197	193
23.3	20mm TA	28, 32, 36	5	207	203
27.8	24mm	28, 32, 36	6	240	-
26.6	Lefty®	28, 32	-	215****	211****
19.6	Lefty®	28, 32, 36	5	200*****	196*****
33.9	QR/FB	28, 32, 36	1, 3	336	331
33.9	10/12mm TA	28, 32, 36	1, 3	320**	315**
33.9	12mm TA	28, 32, 36	1, 3	325	320
38.5	10/12mm TA	32, 36	3	336**	-
39.6	10/12mm TA	32, 36	3	338	333
39.6	12mm TA	32, 36	3	344	339
31.0	QR/FB	28, 32, 36	-	411***	406***
23.0	QR	32, 36	-	150	-
34.0	QR/FB	32, 36	1, 3	282	-
34.2	QR/FB	32, 36	-	427***	-
31.5	QR	32, 36	2, 3	284	-
29.0	QR/FB	32, 36	3	366	-
33.7	QR/FB	32, 36	3	388	-

Upgrade & Conversion Options

- 1: Convertible to 135mm QR/FB axle, 135 x 10mm TA, 135 x 12mm TA, 142 x 12mm TA, and 135mm two piece QR axle
- 2: Convertible to 130mm, 135mm, and 140mm axle widths when using a two piece axle
- 3: Convertible to stainless steel driveshell or XD driveshell
- 4: Convertible to QR and 15mm thru axle
- 5: Convertible to 15mm, 20mm, and *Lefty® axle *Lefty conversion only works on LD hubs with serial# prefix 1720
- 6: Convertible to 15mm, 20mm, 24mm - starting with a 1710 serial # prefix

Wheel Building Specifications

- Spoke Gauge: 13, 14, or 15 gauge
- Spoke Lacing Pattern: 2-or-more cross
- Spoke Hole Diameter: 2.5mm
- Max Spoke Tension: 120 kgf 1200Nm

Limited Warranty

Chris King Precision Components warrants its products to be free from defects in materials or workmanship for the following periods from the original date of purchase:

Headsets: Ten (10) years

Hubs: Five (5) years

Bottom Brackets: Five (5) years

Wheels: The hubs only are warranted for a period of five (5) years. All other wheel components that are not manufactured by Chris King Precision Components such as, but without limitation, rims, spokes, and nipples, are not warranted by Chris King Precision Components.

Accessories: One (1) year

Soft Goods: Ninety (90) days

Any Chris King product that is found by Chris King Precision Components to be defective in materials or workmanship will be repaired or replaced at the discretion of Chris King Precision Components. This warranty does not cover damage or failure resulting from misuse, abuse, alteration, neglect, normal and reasonable wear and tear, crash or impact, failure to perform routine maintenance as instructed, improper installation, or use other than that for which the product was intended.

In order to make a warranty claim, the Chris King product alone (i.e., not including any other equipment such as cassettes, skewers, steering tubes, etc.), together with a copy of the original receipt showing the date of purchase of the product, must be returned to Chris King Precision Components at the address set forth on its website (www.chrisking.com) postage prepaid. If a defect is found, our entire liability and your sole remedy shall be, at our option, free repair or replacement of the Chris King product. Chris King Precision Components shall not be held liable for any indirect, special, punitive, or consequential damages. The warranty does not cover any Chris King Precision Components product where the serial number has been altered or removed.

To the fullest extent permitted by applicable law, this written express limited warranty is in lieu of all other warranties, implied or expressed, and does not cover any representation or warranty made by dealers beyond the provisions of this warranty. If any implied warranties exist by applicable law, such implied warranties shall be limited to the duration of the express limited warranty for the product. Some U.S. states and foreign countries provide rights in addition to those above or do not allow the exclusion or limitation of certain warranties or limitation of liability for certain types of damages. Therefore, the above limitations may not apply to you or there may be laws of a state or foreign country which supersede the above. Any clause of this limited warranty or any disclaimer or limitation of liability contained herein that is declared invalid shall be deemed severable and not affect the validity or enforceability of the remaining clauses.

You are strongly encouraged to register your Chris King product on the website within thirty (30) days of the original date of purchase. Registration will assist us in processing your warranty claim and in expediting our response.

All trademarks, registered trademarks, and logos are of their respective holders.

©King Cycle Group, 2015. All rights reserved.

Printed with soy ink. Contains 100% post consumer recycled paper fiber.



CHRIS KING PRECISION COMPONENTS

2801 NW Nela Street
Portland, OR 97210
phone: 800.523.6008
fax: 503.972.4051
www.chrisking.com
email: info@chrisking.com

rev. 1/27/15