

R45 Disc Centerlock Hub Addendum

Centerlock rotor mounting system licensed by Shimano®

Centerlock is a proprietary mounting system that requires a Shimano® lockring to complete installation of rotor. Chris King R45 Disc Centerlock hubs are compatible with the following Shimano® lockrings:

Compatible Lockrings

- **Front** (Y8K198010) – Typically supplied with genuine Shimano rotor. Or (Y26N98030) – Typically sold as an after market part, also available direct through Chris King under part number PHB355

- **Rear** (Y26N98030) – Typically sold as an after market part, also available direct through Chris King under part number PHB355

Centerlock Rotor Installation:

Front Hubs:

Please follow rotor manufacturer's installation instructions.

Rear Hubs:

Before installing the rear Centerlock rotor the adjusting clamp must be removed. Follow steps below for removal, installation and setting hub preload.

Clamp Removal:

1. Loosen 2.5mm hex bolt on adjusting clamp and then remove R45 QR Insert from main axle assembly by pulling it directly out of the non-drive-side of axle. [Note: If the QR Insert is difficult to remove by hand, insert a long P-Handle or L-shaped 5mm hex wrench into the driveside of the axle. The QR Insert should remove with a light tap to the exposed hex wrench from a plastic or rubber mallet.]

2. Unscrew adjusting clamp and remove it from axle. By pulling onto the adjusting clamp, once free from the threads will also remove steel axle end caps on thru axle assemblies.

[Note: If the Axle End Cap is difficult to remove using only the adjusting

clamp, use a small flat-head screwdriver and insert it into the Axle End Cap slot, twist the screwdriver and the Axle End Cap should come off with the screwdriver.]

3. At this point the Centerlock rotor (or Centerlock to 6-bolt adapter) can be installed. Make sure to follow rotor manufacturer's instructions. (Use Shimano Y26N98030/ Chris King#PHB355 Lockring on rear hubs)

Clamp Install:

1. Thread adjusting clamp onto the protruding threads on the non-drive-side of axle.

2. On QR axles, insert R45 QR insert into non-driveside axle end. On 142mm x 12mm thru axles, ensure steel axle end cap is snapped onto axle by pressing the axle end cap by hand.

3. Snug adjusting clamp up to bearing.

Rear Hub Adjustment:

The R45D Centerlock rear hub features an adjusting clamp and bearing spacer spring that maintain proper bearing preload and seating.

1. Secure the hub/wheel into the bike or truing stand with quick release or frame thru axle system.

2. Push the hubshell toward the driveside. This compresses the bearing spacer spring in the driveshell and ensures proper bearing seating.

3. While maintaining pressure on the hubshell, tighten the adjusting clamp onto axle until it stops against bearing. Do not over tighten.

4. Once adjusting clamp is in position, tighten adjusting clamp with a 2.5mm hex key to 10 inch-pounds (1.13 Nm).

5. Double check adjustment by attaching wheel to bicycle frame. Check for bearing play or binding, and readjust adjusting clamp if needed.

Questions? Please e-mail us at info@chrisking.com or call Customer Service at 800-523-6008

R45 Disc Centerlock Hub specifications and wheel building information										
Hub Type	Axle Type	Axle Width (mm)	Flange Diameter Drive Side & non-Drive Side (mm)	Center Flange Drive Side (mm)	Center to Flange non-Drive Side (mm)	Frame Attachment Options	Available Spoke Hole Drilling	Upgrade & Conversion Options	Weight-Steel (grams)	Weight-Ceramic (grams)
R45 Disc Centerlock QR Front	two piece	100	57.4	30.6	22.2	QR	24,28,32	1	144	140
R45 Disc Centerlock 100mm x 12mm TA Front	one piece	100	57.4	30.6	22.2	TA	24,28,32		143	139
R45 Disc Centerlock 135mm QR Rear	one piece	135	57.4	18.7	33.0	QR	24,28,32	2	267	262
R45 Disc Centerlock 142mm x 12mm Rear	one piece	142	57.4	18.7	33.0	TA	24,28,32		267	259

Wheel Building Specifications
 Spoke Gauge: 13, 14, or 15 gauge
 R45 Disc Lacing Pattern: 2-or-more-cross
 Radial lacing is not permitted on disc hubs of any kind
 Spoke Hole Diameter: 2.5mm
 Spoke Tension: Should not exceed 120kgf (1200N)
 Upgrade and Conversion Options

Upgrade & Conversion Options
 1. Convertible to 100mm x 12mm TA, requires an axle and adjusting clamp
 2. Convertible to 142mm x 12mm TA, requires an axle

R45 Disc Centerlock Front Hub Assembly

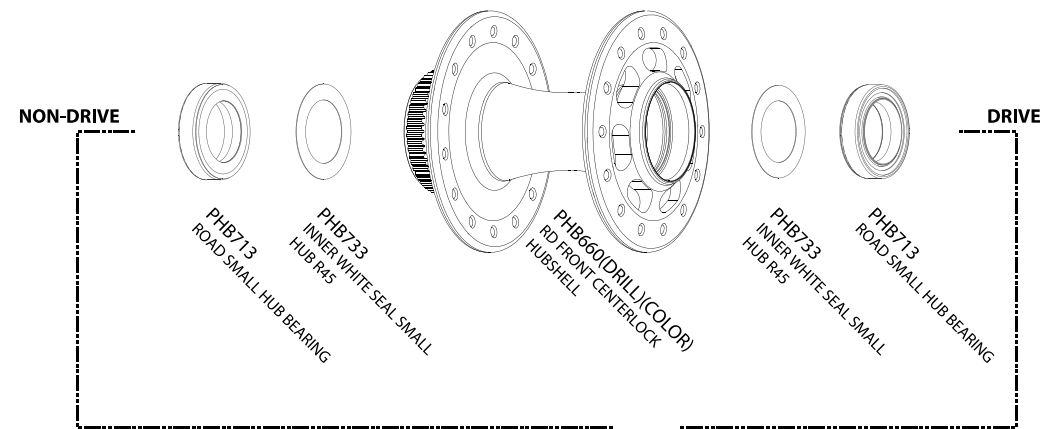

100x12 THRU:

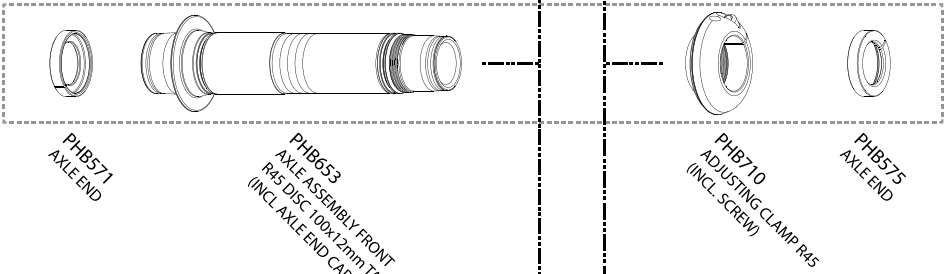

100x9 QR:

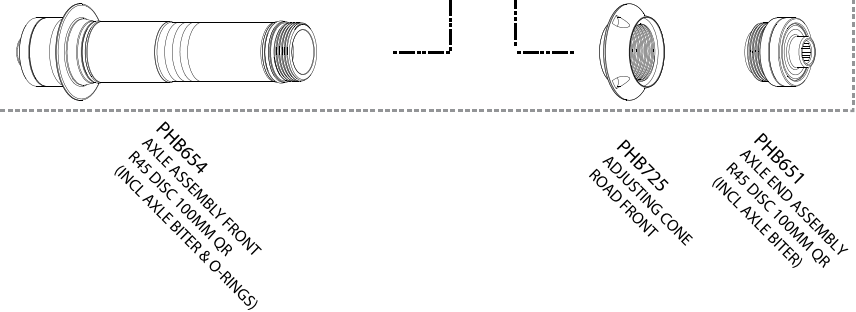

R45 Disc Centerlock Rear Hub Assembly SHIMANO 11SPD COMPATIBLE

***REQUIRES SHIMANO®
Y26N980830 - 15/20 DISC LOCKRING
(PHB355) - CHRIS KING PART#

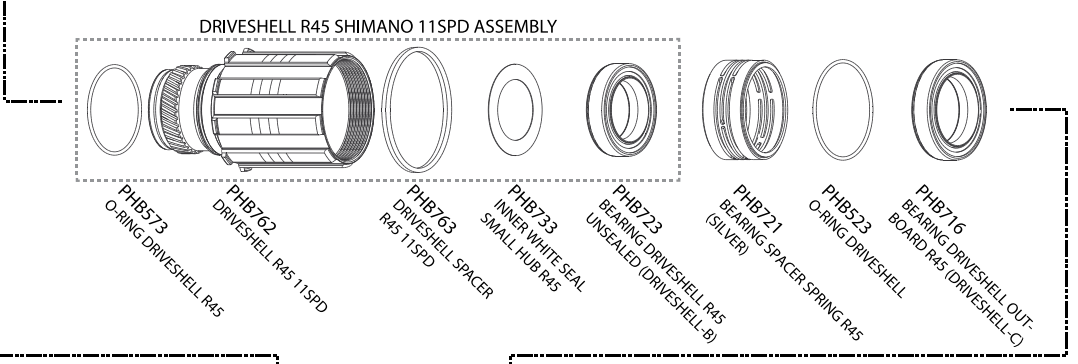
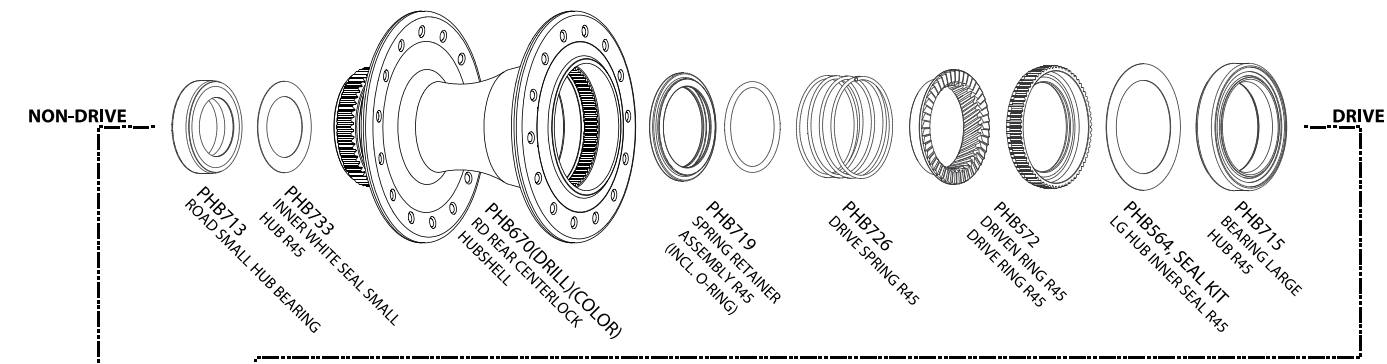

142x12 THRU:

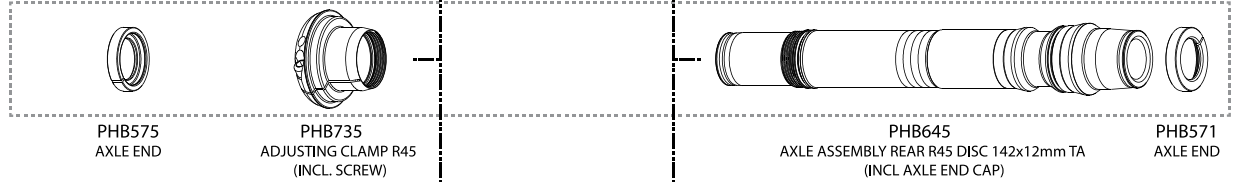

135 QR:

