

CEILING FAN REMOTE CONTROLLER OPERATION AND INSTALLATION INSTRUCTIONS

(Please keep this instruction pamphlet.)

IMPORTANT

YOU MUST SET CEILING FAN MANUAL SWITCH TO HIGH SPEED AND LIGHT KIT (IF ANY) TO ON POSITION BEFORE OPERATING REMOTE CONTROL.

IMPORTANT POINTS TO REMEMBER:

1. Read and save these instructions.
2. Please note that all fixed wiring appliances should be installed by a qualified electrician.
3. The supply to the remote control receiver should be connected through a mains switch, i.e. existing wall switch.
4. Disconnect from power supply at wall switch before working on remote control receiver or ceiling fan.
5. Install receiver into the ceiling fan canopy of the fan to ensure proper protection.
6. This unit is to be used for the control of ceiling fan and in an AC120V 60Hz power supply only.
7. Do not install in damp locations or immerse in water. (For indoor use only.)
8. Do not pull on or cut leads shorter.
9. Do not drop or bump the unit.
10. PLEASE NOTE: The battery will weaken with age and should be replaced before leaking takes place as this will damage the transmitter. Dispose of used battery properly, and keep the battery out of reach of children.
11. CAUTION: To reduce the risk of fire or injury, do not use this product in conjunction with any variable (rheostat) wall control.

INSTALLATION INSTRUCTIONS

CAUTION: INCORRECT WIRE CONNECTION WOULD DAMAGE THIS RECEIVER.

1. Ceiling fan must be set at HIGH speed and light kit (If any) at ON position by pressing the "Light Switch" after installation.
2. Once the connection has been made, the receiver inserts into the drop rod hanging bracket. The canopy comes up to cover the receiver and bracket.

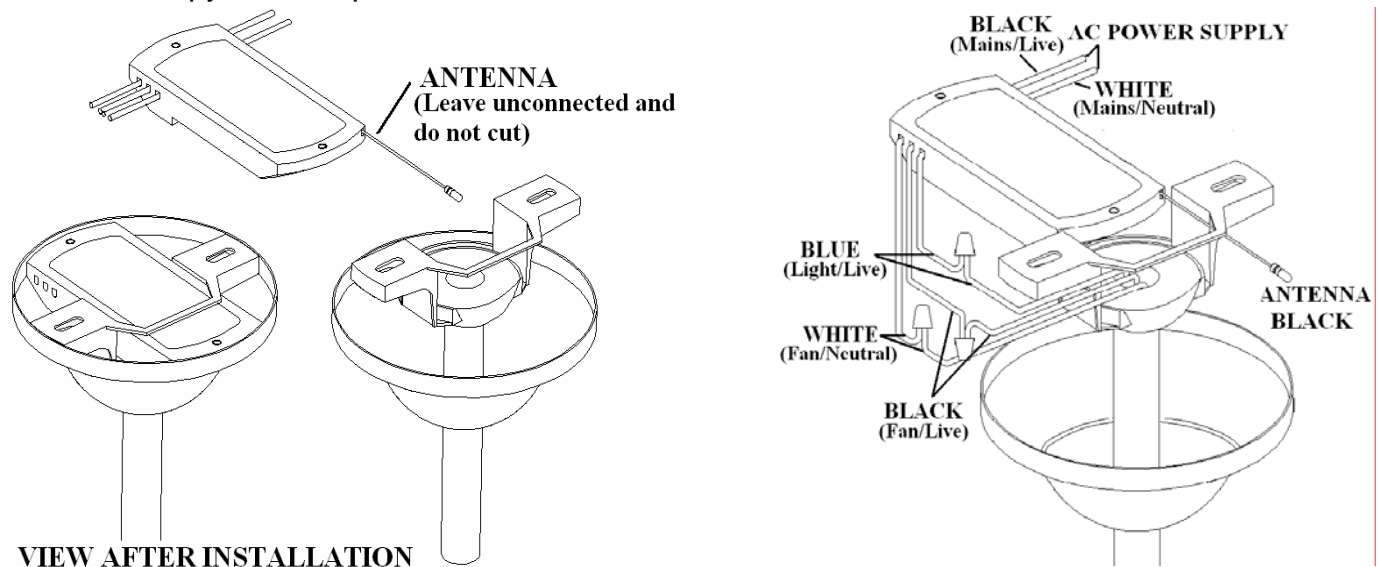

LEARNING PROCESS

1. This unit finished learning process inside manufactory, if replace transmitter or receiver, user need to redo learning process before using this unit. Receiver could remember up to 5pcs transmitter.
2. After installing the unit and power on, open battery cover (with batteries, DC1.5V/AAA 4pcs, installed) and press and use a ball pen to hold "LEARNING" key 1~3seconds, FAN will be turn off and the turn to medium speed, which indicate that learning process finished. Learning effect distance is same with remote's. Please note that must press the "LEARNING KEY" within 60seconds after power on. If just replace batteries, no need to re-learn.
3. Please note that the transmitter can learn in multiple receiver, when doing learning process please make sure not learn in other receiver. Suggest to separate power switches of fans in 2 meter range.

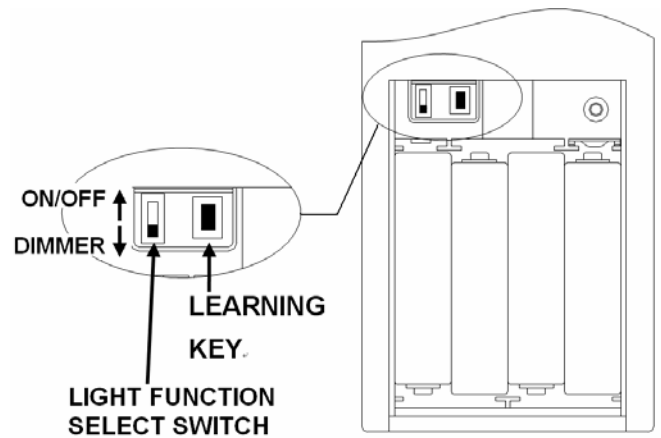

LIGHT FUNCTION SELECT SWITCH

1. If installed energy light onto ceiling fan, please slide the "light function select switch" to on/off position. If installed tungsten light onto ceiling fan, please slide the "light function select switch" to dimmer position.
2. Light load: 190W (Max.) If overload, the receiver will cut off light power automatically. Please change the light load.

FUNCTIONS OF TRANSMITTER



: Touch and release immediately to turn on or off the fan.



: Touch and release immediately to turn on the fan at low/medium/high speed.



TIMER

: Touch this key to select the desired time from 1~12 hours, then fan will turn off automatically after that time.



: Touch and release immediately to turn on or off the light.

Touch and release this key to brighten light to the desired level.

(Tungsten only and light function select switch on dimmer position.)



DELAY 3 Min :

Touch and release immediately, then the light will automatically turn off 3 minutes when the light is on. But when light is off, touch this key, the light will turn on and then turn off after 3 minutes.

TRANSMITTER

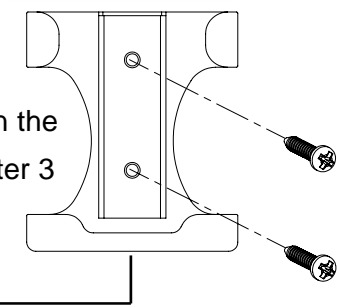
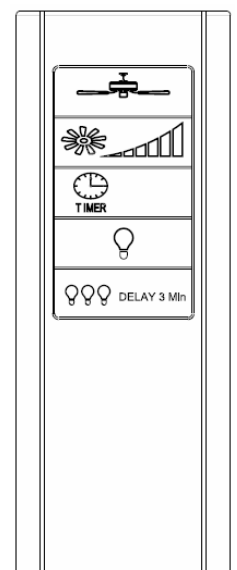

Installation of Transmitter Wall Mount Holder with two screws.

**FEDERAL COMMUNICATIONS COMMISSION
INTERFERENCE STATEMENT**

This equipment has been tested and found to comply with the limits for a Class B digital device, pursuant to Part 15 of the FCC Rules. These limits are designed to provide reasonable protection against harmful interference in a residential installation. This equipment generates, uses and can radiate radio frequency energy and, if not installed and used in accordance with the instructions, may cause harmful interference to radio communications. However, there is no guarantee that interference will not occur in a particular installation. If this equipment does cause harmful interference to radio or television reception, which can be determined by turning the equipment off and on, the user is encouraged to try to correct the interference by one or more of the following measures:

- Reorient or relocate the receiving antenna.
- Increase the separation between the equipment and receiver.
- Connect the equipment into an outlet on a circuit different from that to which the receiver is connected.
- Consult the dealer or an experienced radio/TV technician for help.

CAUTION:

To assure continued FCC compliance:

Any changes or modifications not expressly approved by the grantee of this device could void the user's authority to operate the equipment.

FCC ID : KUJCE9803

This device complies with Part 15 of the FCC Rules. Operation is subject to the following two conditions: (1) This device may not cause harmful interference, and (2) this device must accept any interference received, including interference that may cause undesired operation.