

CipherLab Reference Manual

RS51

Mobile Computer
(Android™ 6.0, Marshmallow)

Version 1.00



PREFACE

COPYRIGHT

Copyright © 2017 CIPHERLAB CO., LTD.

All rights reserved

The information contained in this document, including all pictures, illustrations and software, is the proprietary information of CIPHERLAB CO., LTD. and its respective legal owners; it is protected by copyright laws and international copyright treaties, as well as other intellectual property laws and treaties, with all rights reserved.

In no event and by no part shall this document be reproduced, stored in a retrieval system, or transmitted in any form or by any means including but not limited to electronic, mechanical, photocopying, and recording without the prior written consent of CIPHERLAB CO., LTD. Any reverse engineering of software is also prohibited.

DISCLAIMER

The information herein is subject to change without notice. The information and the intellectual property herein are confidential between you and CIPHERLAB CO., LTD. and remain the exclusive property of CIPHERLAB CO., LTD. and its respective legal owners. Should you find any problems in this document, please report them to CIPHERLAB in writing. CIPHERLAB does not warrant this document is error-free.

TRADEMARK RECOGNITION

CipherLab logo is a registered trademark of CIPHERLAB CO., LTD. All other brands, products and services, and trademark names are the property of their registered owners. The editorial use of these names is for identification as well as to the benefit of the owners, with no intention of infringement.

Google, Google Play, Android and other marks are trademarks of Google Inc.

CONTACT

For product consultancy and technical support, please contact CIPHERLAB's sales representative in your local area. You may also visit CIPHERLAB web site for more information.

CIPHERLAB CO., LTD.

Website: <http://www.CipherLab.com>

IMPORTANT NOTICES

FOR USA

FCC ID : Q3N-RS51

This equipment has been tested and found to comply with the limits for a **Class B** digital device, pursuant to Part 15 of the FCC Rules. These limits are designed to provide reasonable protection against harmful interference in a residential installation. This equipment generates, uses and can radiate radio frequency energy and, if not installed and used in accordance with the instructions, may cause harmful interference to radio communication. However, there is no guarantee that interference will not occur in a particular installation. If this equipment does cause harmful interference to radio or television reception, which can be determined by turning the equipment off and on, the user is encouraged to try to correct the interference by one or more of the following measures:

- ▶ Reorient or relocate the receiving antenna.
- ▶ Increase the separation between the equipment and receiver.
- ▶ Connect the equipment into an outlet on a circuit different from that to which the receiver is connected.
- ▶ Consult the dealer or an experienced radio/TV technician for help.

This device complies with Part 15 of the FCC Rules. Operation is subject to the following two conditions: (1) This device may not cause harmful interference, and (2) this device must accept any interference received, including interference that may cause undesired operation.

FCC Caution:

Any changes or modifications not expressly approved by the party responsible for compliance could void the user's authority to operate this equipment.

This transmitter must not be co-located or operating in conjunction with any other antenna or transmitter.

Find the certificate information from :

Setup → About Phone → Certificate

Mobile Computer

Model : RS51

US

FCC ID : Q3N-RS51



This device complies with Part 15 of the FCC Rules.

Operation is subject to the following two conditions:

- (1) This device may not cause harmful interference, and
- (2) this device must accept any interference received, including interference that may cause undesired operation.

FOR PRODUCT WITH LASER



- ▶ This laser component emits FDA / IEC Class 2 laser light at the exit port. Do NOT STARE INTO BEAM DIRECTLY.
- ▶ Do not aim the beam at the eyes.
- ▶ Any adjustments or performance excluding those specified may result in hazardous laser light exposure.

ENVIRONMENT

- ▶ Operate the handy terminal at ambient temperatures from -20 °C to 50 °C and with humidity range from 10% to 90%.
- ▶ Store the device at ambient temperatures from -30 °C to 70 °C and with humidity range from 5% to 95%.
- ▶ Charge the device at ambient temperatures from 0°C to 35°C.
- ▶ This device is built with a dust-proof and splash-proof structure that conforms to protection class IP67.

SPECIFIC ABSORPTION RATE (SAR) INFORMATION

The product complies with the FCC portable RF exposure limit set forth for an uncontrolled environment and are safe for intended operation as described in this manual. The further RF exposure reduction can be achieved if the products can be kept as far as possible from the user body or set the device to lower output power if such function is available.

Body-worn Operation

This device was tested for typical body-worn operations. To comply with RF exposure requirements, a minimum separation distance of 10 mm must be maintained between the user's body and the handset, including the antenna. Third-party belt-clips, holsters, and similar accessories used by this device should not contain any metallic components. Body-worn accessories that do not meet these requirements may not comply with RF exposure requirements and should be avoided.

The SAR test distance is Head (0 mm), Body (10 mm) and Hotspot (10 mm).

FCC SAR Value (Standard limit is 1.6 W/Kg)

USA (1g): Max. **1.52** W/Kg

A minimum separation distance of 0.5 cm must be maintained between the user's body and the device, including the antenna during body-worn operation to comply with the RF exposure requirements in Europe.

To compliance with RF Exposure requirements in Europe, third-party belt-clips, holsters or similar accessories used by this device should not contain any metallic components. The use of accessories that do not satisfy these requirements may not comply with RF exposure requirements, and should be avoided.

CE SAR Value (Standard limit is 2 W/Kg)

EU (10g): Max. **1.6** W/Kg

SAFETY PRECAUTIONS

RISK OF EXPLOSION IF BATTERY IS REPLACED BY AN INCORRECT TYPE. DISPOSE OF USED BATTERIES ACCORDING TO THE INSTRUCTIONS.

- ▶ For people's safety
- ▶ Do not listen at high volume levels for long periods to prevent possible hearing damage.
- ▶ Do not operate this device while walking, cycling or car driving.
- ▶ For the equipment
- ▶ Do not use any batteries or charging devices which are not originally sold
- ▶ Do not replace the battery with an incorrect type, to avoid the risk of heat generation, fire, or explosion.
- ▶ Do not disassemble, incinerate or short circuit the battery.
- ▶ Do not touch the contact pins of the battery pack.
- ▶ Do not expose the handy terminal or battery to any flammable sources.
- ▶ Do not expose the handy terminal to extreme temperatures or soak it in water.
- ▶ Do not use any pointed or sharp objects against the screen surface.
- ▶ Do not use the styluses which are not supplied, to prevent possible scratches to the touch screen.
- ▶ Water residue on the touch screen may cause abnormal behaviors or the fall of its sensitivity levels.
- ▶ On the surface of the terminal and the barcode reading window, the fog or water drops caused by low temperatures may influence barcode reading.
- ▶ Do not use bleaches or cleaners to clean the device. Use a clean, wet cloth instead.

BATTERY

- ▶ The main battery may not be charged to full for shipment. Charge the main battery to full before using the handy terminal for the first time.
- ▶ Main battery: The main battery powers the handy terminal to work. It takes approximately 4 hours to charge an empty main battery to full. The charging LED above the screen will light up in red while charging and will turn green when charging is complete.
- ▶ When the main battery is removed, RTC retention will be maintained for at least 30 minutes.
- ▶ Backup battery: The backup battery is mounted on the main board. Its role is to temporarily keep the handy terminal in suspension when the main battery is drained out so data in DRAM will be retained. The backup battery takes approximately 3.5 hours to charge to full by the main battery or power adapter.
- ▶ It is recommended to charge the battery at room temperature (18°C to 25°C) for optimal performance.
- ▶ Battery charging stops when ambient temperature drops below 0°C or exceeds 40°C.
- ▶ In order to prevent system from shutting down after the battery is drained out, keep a fresh battery for replacement at all times, or connect the handy terminal to an external power.
- ▶ If there are drippings or dust on the device or battery pack, wipe them away with a soft clean cloth before battery replacement.
- ▶ Turn off the power before battery replacement.

- ▶ If you want to put away the handy terminal for a period of time, remove the battery pack from the handy terminal's battery compartment. Store the handy terminal and battery pack separately.
- ▶ Recycle batteries in a proper way for the green-environment issue.

SCANNER

- ▶ Scan a 1D barcode
 - ▶ 1) Open ReaderConfig and tap **Scan Test** on the menu bar.
 - ▶ 2) Aim the scanning window at the barcode to read. Move the device, having the barcode located in the center of the scanning area.
 - ▶ 3) Press any of the two side triggers. The scanning light beams to read the printed barcodes. The buzzer beeps after scanning. The scanning light goes off once the data is decoded, or when the decode timeout period has passed.
- ▶ Scan a 2D barcode
 - ▶ 1) Open ReaderConfig and tap **Scan Test** on the menu bar.
 - ▶ 2) Aim the scanning window at the barcode to read. Move the device, having the barcode located in the center of the scanning area.
 - ▶ 3) Press any of the two side triggers. The scanning light beams to read the printed barcodes. The buzzer beeps after scanning. The scanning light goes off once the data is decoded, or when the decode timeout period has passed.

CONNECTION

- ▶ Via Bluetooth or WLAN
- ▶ Connection may fail when the handy terminal is around other wireless machines or power cables as the radio frequencies of those may cause interferences.
- ▶ If communication fails, move the devices much closer to each other, and try to communicate again
- ▶ After turning on, Bluetooth power is sustained even when the handy terminal is suspended. However, if the power mode is switched to Airplane Mode, Bluetooth power will be turned off regardless of the settings.
- ▶ Not Charging could be the result of battery damage, battery's failure to touch the connector or AC plug coming off.
- ▶ Charging error could be due to high battery temperature.

CARE & MAINTENANCE

- ▶ When the body of the handy terminal gets dirty, use a clean, wet cloth to wipe off dust and debris. DO NOT use bleaches or cleaners.
- ▶ Use a clean, non-abrasive, lint-free cloth to wipe dust off the LCD touch screen. DO NOT use any pointed or sharp objects against the surface. Always keep the LCD dry.
- ▶ If you want to put away the handy terminal for a period of time, download the collected data to a host computer, and then remove the battery pack from the handy terminal's battery compartment. Store the handy terminal and battery pack separately.
- ▶ If you encounter malfunction on the handy terminal, write down the specific scenario and consult your local sales representative.

USA E-LABEL

Mobile Computer

Model : RS51

US

FCC ID : Q3N-RS51



This device complies with Part 15 of the FCC Rules.
Operation is subject to the following two conditions:
(1) This device may not cause harmful interference, and
(2) this device must accept any interference received,
including interference that may cause undesired operation.

RELEASE NOTES

Version	Date	Notes
1.00a	Mar 23, 2016	2 nd release
1.00	Nov 10, 2016	Initial release

CONTENTS

- PREFACE** - 2 -
 - Copyright - 2 -
 - Disclaimer - 2 -
 - Trademark Recognition..... - 2 -
 - Contact..... - 2 -
- RELEASE NOTES** - 10 -
- CONTENTS** 11
- INTRODUCTION** 12
 - Inside the Package..... 12
 - Accessories..... 12
- QUICK START** 13
 - Overview..... 13
 - Installing Battery 15
 - Installing SIM Card, SAM Card and Memory Card..... 17
 - 1.1.1. Power On/Off Mobile Computer 18
 - 1.1.2. Homescreen Selection 19
 - 1.1.3. Using Hardware Buttons 20
 - 1.1.4. Connecting Headset 20
 - 1.2. Charging & Communication 21
 - 1.2.1. Charge Mobile Computer 21
 - 1.2.2. Wired Data Transmission 25
- SPECIFICATIONS** 26
 - Platform, Processor & Memory..... 26
 - Communication & Data Capture 27
 - Electrical Characteristics 28
 - Physical Characteristics 28
 - Environmental Characteristics 29
 - Programming Support..... 30

INTRODUCTION

The **RS51** Mobile Computer, powered by Android™ 6.0, Marshmallow, is light-weight, easy to use, and provides more powerful and handy tools.

Specifically designed to work as an industrial PDA, it provides rich options of data collection, voice and data communication, long-lasting working hours, and so on. Its large color transmissive display guarantees ease in reading in all lighting conditions. Integrated with Bluetooth v4.1, v2.1+EDR and 802.11 a/b/g/n/ac technologies, the mobile computer also includes a GSM/UMTS/LTE module to gain greater speeds and optimal mobility. In particular, an integrated GNSS (Global Navigation Satellite System) receiver is made available for use with third-party location-based applications.

This manual serves to guide you through how to install, configure, and operate the mobile computer. The Care & Maintenance section is specifically crucial for those who are in charge of taking care of the mobile computer.

We recommend you to keep one copy of the manual at hand for quick reference or maintenance purposes. To avoid any improper disposal or operation, please read the manual thoroughly before use.

INSIDE THE PACKAGE

The following items are included in the kit package. Save the box and packaging material for future use in case you need to store or ship the mobile computer.

- ▶ **RS51** Mobile Computer
- ▶ Rechargeable Li-ion battery pack
- ▶ Wrist Band
- ▶ Snap-on USB Charging & Communication Cable
- ▶ AC Power Adaptor
- ▶ Quick Guide

ACCESSORIES

- ▶ Single Cradle with USB Communication
- ▶ 4-slot Battery Charger Cradle
- ▶ Car Charger Cable

QUICK START

OVERVIEW

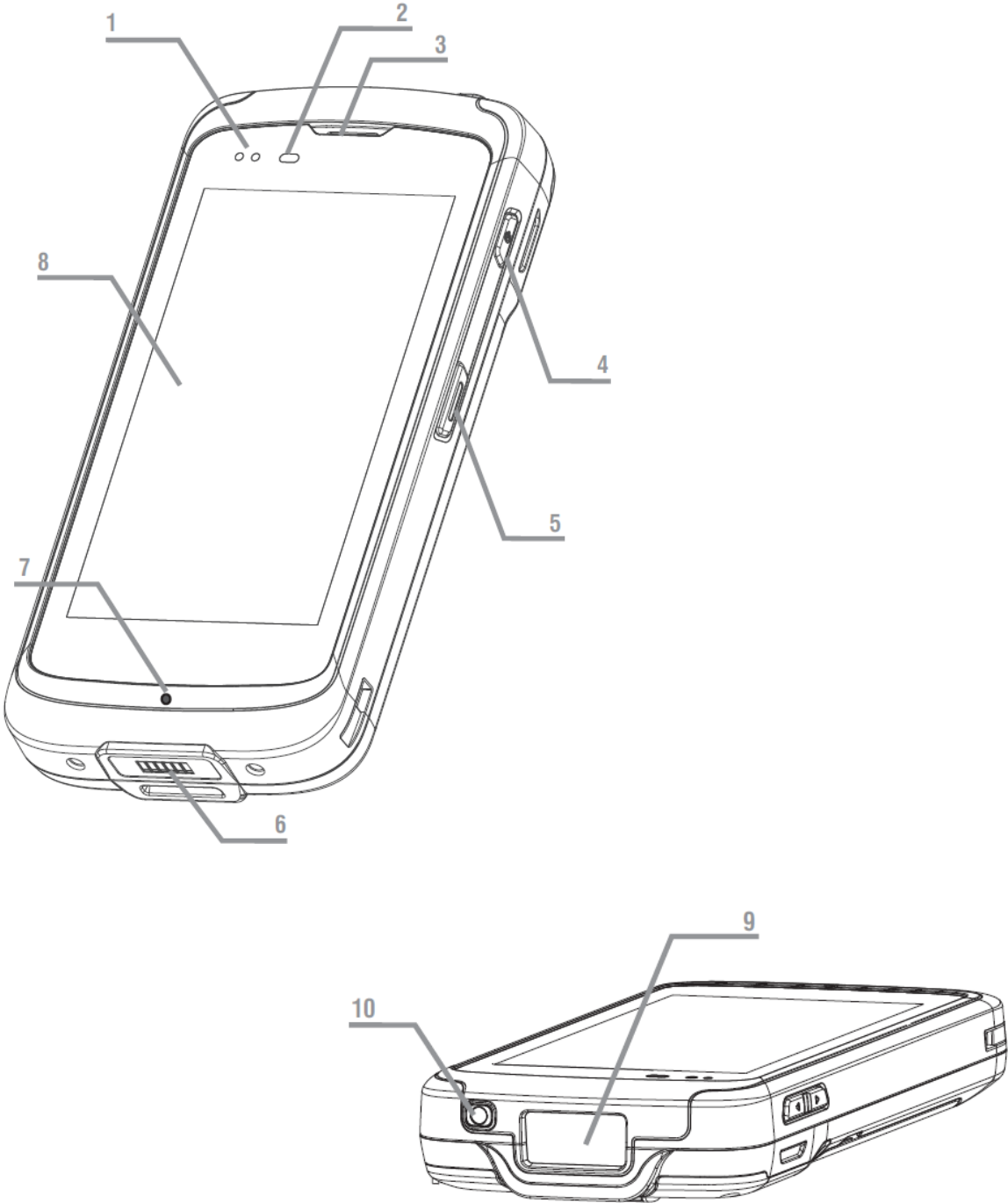

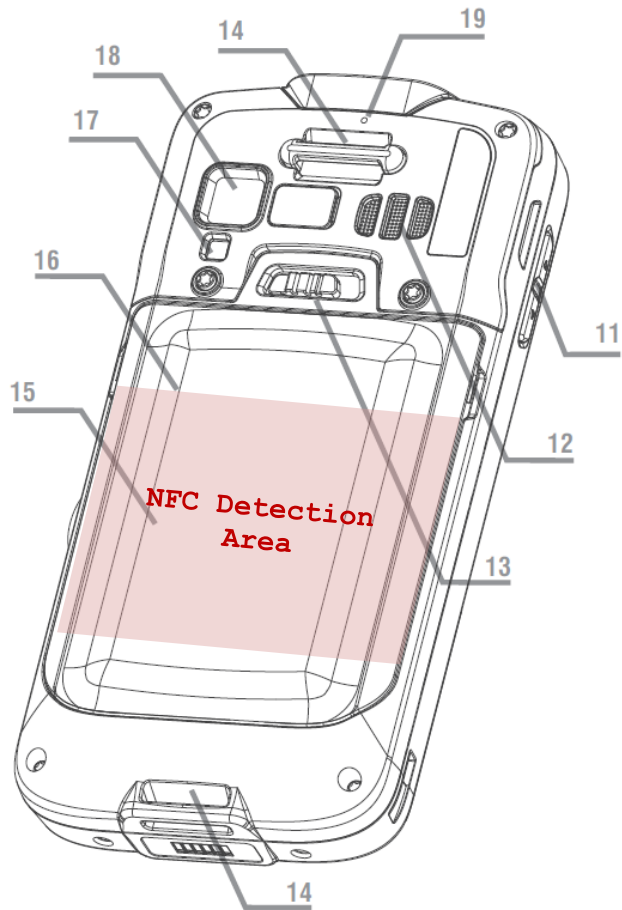

No.	Description	No.	Description
1	Status LED	2	Proximity+ALS Sensor
3	Phone Receiver	4	Power Button
5	Side Key	6	Microphone
7	Charging & Communication Pins	8	Touchscreen
9	Scan Window	10	Headset Jack
11	Volume Buttons	12	Loudspeaker
13	Wrist Band Hole	14	Battery Latch
15	NFC Detection Area	16	Battery (with Cover)
17	Camera Flash	18	Camera Lens
19	Rear Microphone		

INSTALLING BATTERY

For shipping and storage purposes, the mobile computer and the main battery are saved in separate packages.

Note: Any improper handling may reduce the battery life.

To install the main battery:

- 1) Insert the main battery with the contact pins facing the lower end. Fix the lower edge of the battery first.
- 2) Push the upper end in, the battery latch will click into place with a “**click**” sound

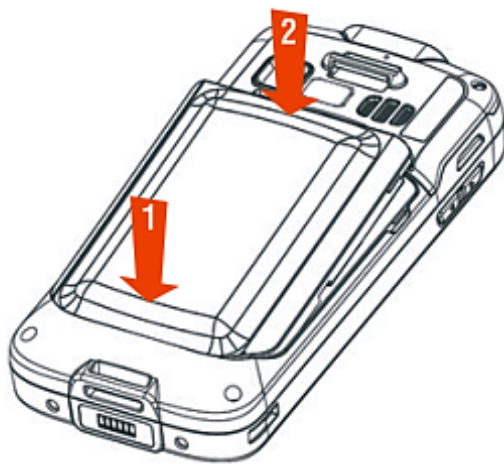

IMPORTANT CHARGING INFORMATION

Power Supply	Input: AC 100-240V, 50-60Hz; output: 5V/2A CipherLab approved
Battery Pack (Optional)	3.8V 4000mAH/3.8V 5300mAH (Standard/Extended) rechargeable Li-ion CipherLab proprietary
Charging time	Approx. 5 hours/6 hours (Standard/Extended battery) via adapter

REMOVE BATTERY

- 1) Press down the power key and tap "**Power off**" to shut down this device.
- 2) Slide the key latch **Right**, the battery will be unlocked with a "**click**" sound.
- 3) Lift the battery up from its upper end.

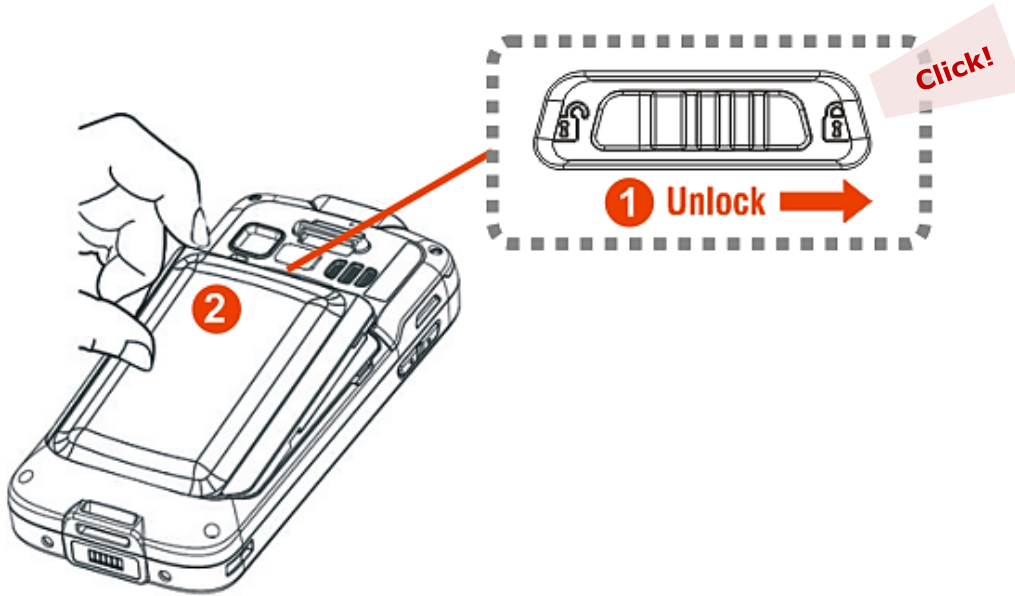

INSTALLING SIM CARD, SAM CARD AND MEMORY CARD

The **RS51** Mobile Computer is equipped with two SIM card slots, one SAM card slot and one memory card slot.

To insert the cards:

- 1) Remove the battery.
- 2) Insert your fingernail into the notch above the inner lid that protects the card sockets chamber and lift it up.

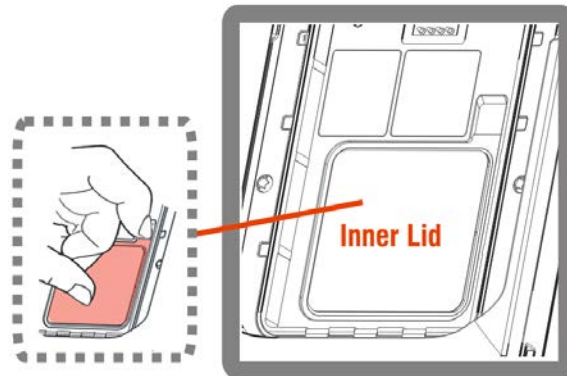

- 3) After the chamber is revealed, insert SIM cards, the SAM card and the microSD card into their respective sockets. Close and push back the hinged cover till a "click" sounds.

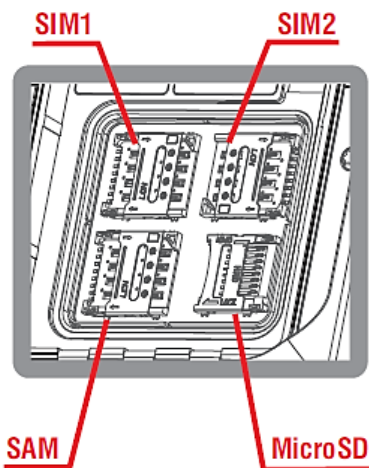

- To install the cards:
- 1) Slide the hinged cover back.
 - 2) Swing the top open, and then insert the card.
 - 3) Close the hinged cover, and then push it back.

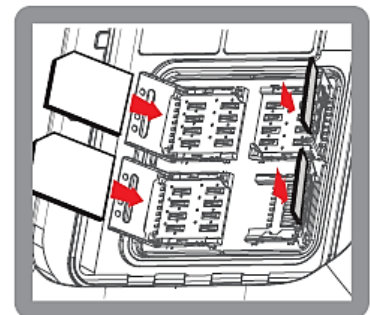

- 4) Replace the inner lid.
- 5) Replace the battery.

REMOVE CARDS

- 1) Remove the battery.
- 2) Remove the inner lid.
- 3) Unlock the card hinge cover and remove the card.
- 4) Replace the inner lid and the battery.

1.1.1. POWER ON/OFF MOBILE COMPUTER

POWER ON

To power on the mobile computer, press and hold the power button  located on the upper right side of the device. The mobile computer will turn on and show the [錯誤! 找不到參照來源。](#) after splash screen.

Note:

For the mobile computer to power on, the battery cover must be secured in place.

Warning:

When powering on this mobile computer, if you accidentally enter a hidden advanced boot menu, please use **Volume Up** key to select and **Volume Down** key to confirm **[Normal Boot]** to return to the normal booting process.

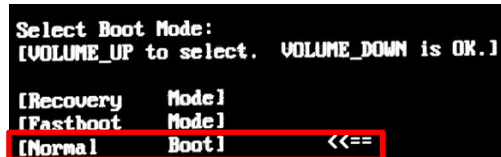

Any system failure, data loss or unexpected consequences arising from your entering the other two options - **[Recovery Mode]** and **[Factory Mode]** is out of CIPHERLAB 's warranty coverage.

POWER OFF

To power off the mobile computer, press and hold the power button  for more than three seconds. A menu will appear on-screen which allows you to power off the device. Make sure all user data and tasks have been stored before tapping on **Power off**.

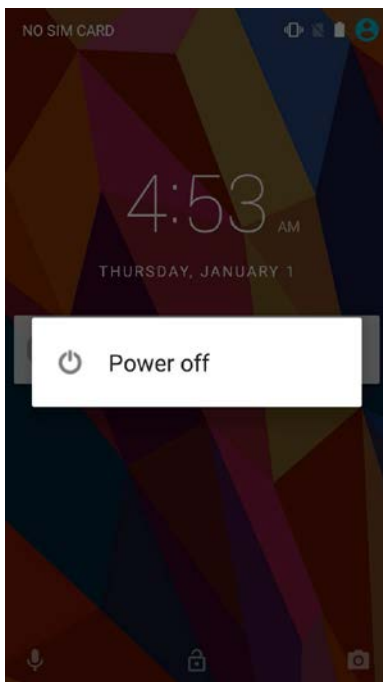

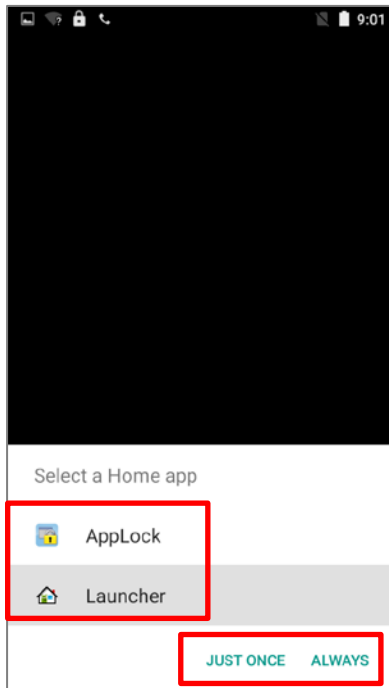

1.1.2. HOMESCREEN SELECTION

Upon the first time you launch the system, a **Select Home app** window will pop up to request your immediate choice of home screen. By selecting "**AppLock**", you will directly enter AppLock application (please refer to *AppLock User Guide* for detailed instructions on AppLock settings) to start configuring the interface provided to normal users of this device; by selecting "**Launcher**", you will enter the default Android™ 6.0 home screen.



1.1.3. USING HARDWARE BUTTONS

On the bottom of the mobile computer are three hardware buttons that deliver the following functions:

Button	Function	Description
	Back button	Returns to the previous screen or closes the active window or keyboard.
	Home button	Displays the Home screen.
	Recent apps button	Opens a list of recently used applications.

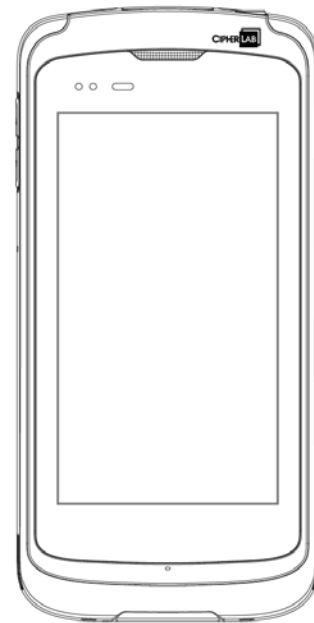

1.1.4. CONNECTING HEADSET

The headset jack is located on the top of the mobile computer. You can use the headset for audio playback or communication via the phone application, audio instant messaging, etc.

- 1) Flip up the rubber cover.
- 2) Connect the headset to the headset jack.
- 3) Replace the rubber cover.

1.2. CHARGING & COMMUNICATION

1.2.1. CHARGE MOBILE COMPUTER

The main battery may not be charged to full for shipment. When you first receive the kit package, you will need to charge the main battery to full before using the mobile computer. You may use the Snap-on Charging Cable or Charging Cradle along with a power adapter to charge the mobile computer.

Your device can be charged as well when connected to a computer via USB cable; however, charging from a USB port on a computer is slower than charging using a supplied Snap-on Charging Cable or Charging Cradle because the voltage and amperage the computer provides is lower than in the case of using a normal charging method.

CHARGING TIME

Main battery: The main battery powers the mobile computer to work. It takes approximately 4 hours to charge an empty main battery to full. The charging LED above the screen (located on the right) will light up in red while charging and will turn green when charging is complete.

When the main battery is removed, RTC retention will be maintained for at least 30 minutes.

Backup battery: The backup battery is mounted on the main board. Its role is to temporarily keep the mobile computer in suspension when the main battery is drained out so data in DRAM will be retained. The backup battery takes approximately 3.5 hours to charge to full by the main battery or power adapter.

CHARGING TEMPERATURE

It is recommended to charge the battery at room temperature (18°C to 25°C) for optimal performance.

Please note that battery charging stops when ambient temperature drops below 0°C or exceeds 40°C.

OPERATION ON BATTERY POWER

When 802.11a/b/g/n, GSM/GPRS/EDGE/WCDMA/UMTS/HSDPA/HSUPA/HSPA+/LTE, Bluetooth v4.1 & v2.1+EDR and GPS are all enabled on battery power, the main battery level will drop down substantially. Prolonged use of the display and continued scanning of barcodes will also affect battery level.

In order to prevent system from shutting down after the battery is drained out, we suggest that you keep a fresh battery for replacement at all times, or connect the mobile computer to an external power.

USE SNAP-ON CHARGING CABLE

The Snap-on Charging Cable provides a convenient way to charge your mobile computer.

- 1) Fasten the Snap-on Charging Cable to the lower end of the mobile computer.
- 2) Connect the other end of the cable to the adapter.
- 3) Fix the adapter plug onto the adapter, and plug in into an electrical outlet.

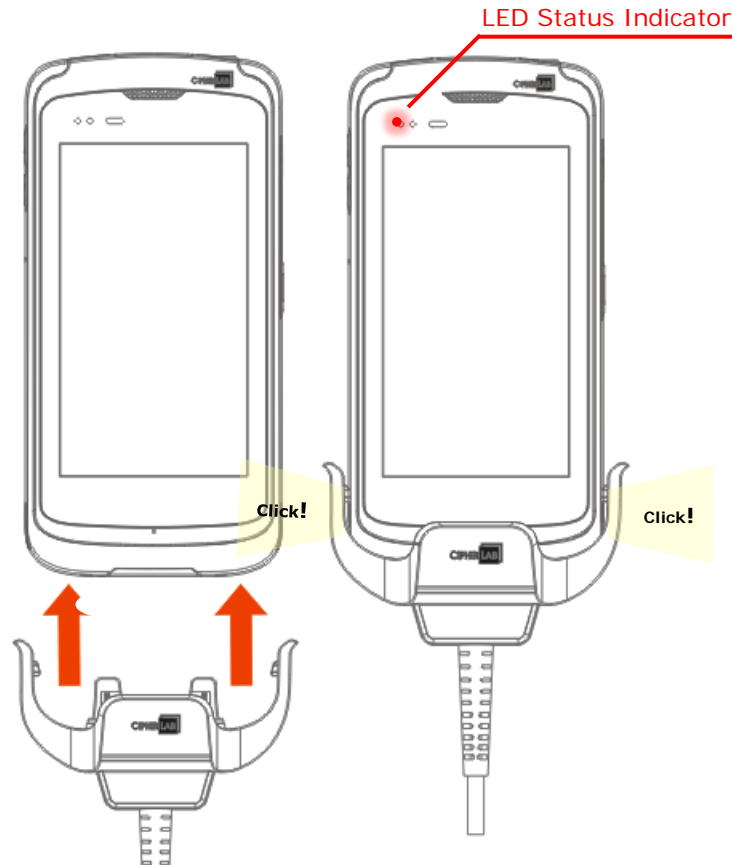

While the device battery is being charged, the LED on mobile computer will indicate charging status.

LED Indicator	Status	Description
Charging	Red, solid	Charging the mobile computer
	Red, blink	Charging error
	Green, solid	Charging complete
	No light	Charging error (charging will stop)

Note:

The Snap-on Charging Cable is for charging only. For data communication, use the micro USB cable to connect the mobile computer to your PC or laptop.

USE CHARGING CRADLE

The Charging Cradle charges your mobile computer and a spare battery at the same time.

Presents charging compartment for mobile computer and spare battery

Provides micro USB socket on the back for charging

Supports USB Host Mode via a USB OTG cable

Completes charging in approximately 5 hours

Two LEDs, one for power connection status and one for battery charging status

Adapter input 100-240V, AC, 50/60Hz; output 5V, DC, 2A.

Note:

The Charging Cradle is for charging only. For data communication, use the micro USB cable to connect the mobile computer to your PC or laptop.

To charge your mobile computer on the Charging Cradle:

- 1) Insert the mobile computer onto the Charging Cradle. Press the mobile computer down till you hear a 'click' to make sure it is secured in the charging station. If the hardshell is installed on the mobile computer, remove the cap on the Cradle's charging station, and insert the mobile computer.
- 2) Connect the adapter to the Cradle, and plug the other end into an electrical outlet.

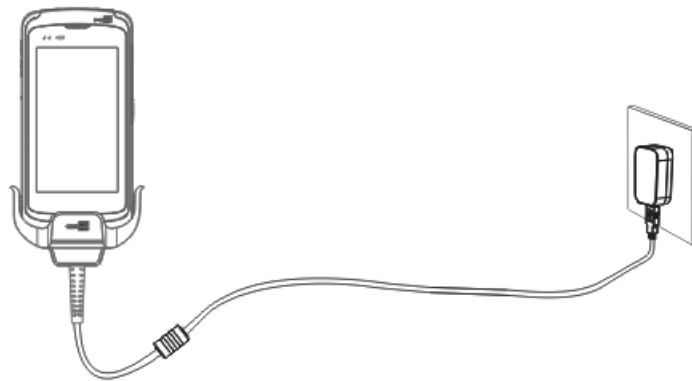

The status of the mobile computer charging is shown on the device itself, while the LED indicator on RS51 Charging Cradle shows the status of battery charging as below:

Cradle LED Indicator	Status	Description
Charging	Red, solid	Charging the battery
	Red, blink	Charging error
	Green, solid	Charging complete
	No light	Not charging

Note:

- (1) **Not Charging** could be the result of battery damage, battery's failure to touch the connector, or AC plug coming off.
 - (2) *Charging error* could be due to high battery temperature.
-
-

1.2.2. WIRED DATA TRANSMISSION

Use the micro USB cable to connect the mobile computer to your PC for data transmission.

- 1) Connect your device to the computer with supplied USB cable.

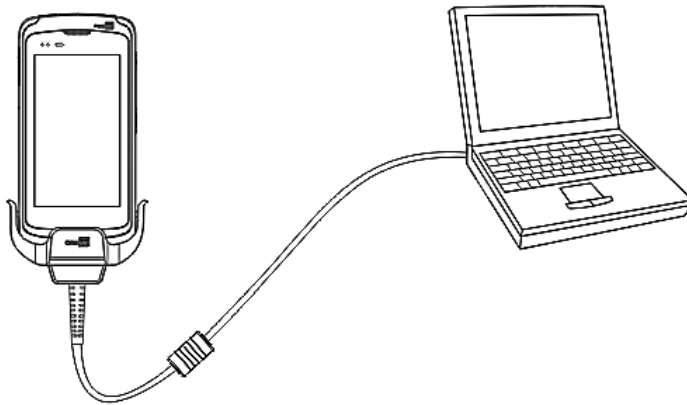

- 2) Swipe down from the status bar to reveal Notifications Drawer.
- 3) Tap **“USB for Charging”** to enter USB options. By default, the device will be in charging mode, in which you are unable to access the files on this device from the PC client. To transfer all types of files between your device and PC, choose **“File transfers”**. To transfer videos and photos, you can select **“Photo transfer (PTP)”**, in which your device will share only videos and photos in *DCIM* and *Pictures* folders.

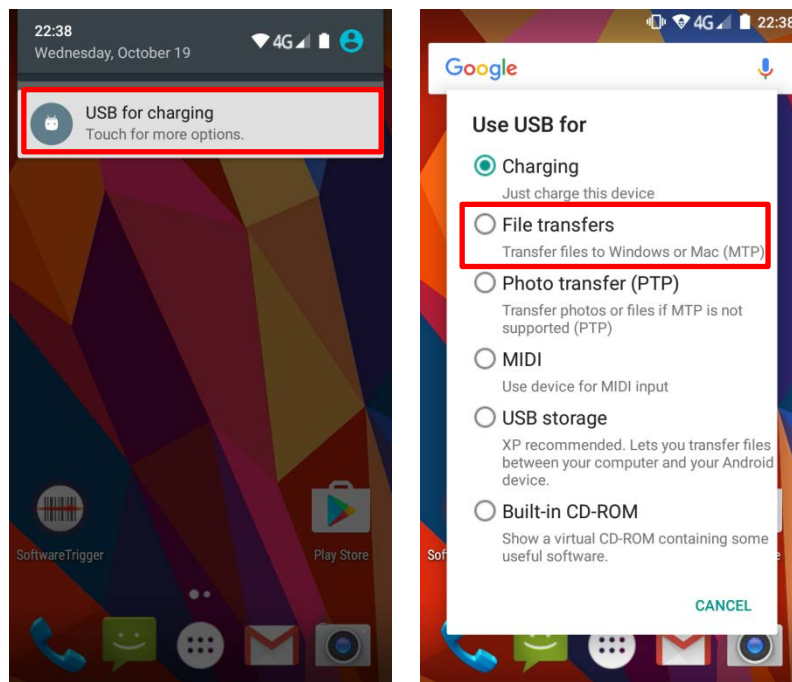

SPECIFICATIONS

PLATFORM, PROCESSOR & MEMORY

Operating System & CPU

OS Version	Android™ 6.0 Marshmallow with GMS Certified
CPU	Cortex A53 Octa-core
Memory	
ROM	16GB eMMC
RAM	2GB
Expansion Slot	One microSDHC card slot (up to 32GB) SDXC supported (up to 2TB)
	Micro SIM socket x2 Micro SAM socketx1

COMMUNICATION & DATA CAPTURE

Communication

USB Client	USB 2.0 OTG
WPAN	Bluetooth Class II, v4.1 and v2.1+EDR (2402~2480 MHz: 3.3dBm)
WLAN	IEEE 802.11 a/b/g/n/ac networking (2412~2472 MHz: 18.41dBm 5180~5240MHz: 21.06dBm, 5260~5320MHz: 21.46dBm, 5500~5700MHz: 21.90dBm, 5745~5825MHz: 14.30dBm(USA only)) Operations in the 5.15-5.35GHz band are restricted to indoor usage only.
WWAN	Built-in WWAN modem for Quadband GSM, UMTS, LTE functions: GSM/GPRS/EDGE/WCDMA/UMTS/HSDPA/HSUPA/HSPA+/LTE Worldwide Frequency bands: GSM/GPRS/EDGE 880~915, 925~960MHz: 29dBm 1710~1785, 1805~1880MHz: 30dBm WCDMA/UMTS/HSDPA/HSUPA: B1, B8 1922.4~1977, 2112.4~2167.6: 24dBm 880~915, 925~960: 24dBm LTE: B1, B3, B7, B8, B20, B28, B38, B40 1922.4~1977, 2112.4~2167.6MHz: 23dBm 1710~1785, 1805~1880MHz: 23dBm 2500~2570, 2620~2690MHz: 23dBm 880~915, 925~960MHz: 23dBm 832~862, 791~821MHz: 23dBm 718~748, 758~773MHz: 23dBm 2570~2620MHz: 23dBm 2300~2399.9MHz: 23dBm Americas GSM : 850/1900 UMTS : B2, B4, B5 CDMA : BC0, BC1, BC10 LTE : B2, B4, B5, B7, B12, B13, B17, B25, B26, B38, B41
GPS	BDS(1561.098MHz), Galileo/GPS (1575.42MHz), GLONASS(1602.000MHz)

Data & Image Capture

Digital Camera	Rear: 8 Mega pixels with user-controllable flash
Barcode Reader	2D CCD Imager (Zebra SE-4750)
HF Reader	RFID(13.56MHz) ISO14443A/B (Mifare), ISO15693 (Felica) ▶ Supports NFC (Peer-to-peer, Card reader, Card emulation)

ELECTRICAL CHARACTERISTICS

Batteries

Main Battery Pack	Rechargeable Li-ion battery: 3.8V, 5300mAh Charging temperature: 0-35°C Minimum charging time: 5 hours @25°C Please Charge batteries in temperatures from 0°C to 35°C. To ensure that the battery is being charged under a safe condition, the battery may disable charging when ambient temperature drops below 0°C or exceeds 40°C, and resume charging after its temperature falls within the acceptable range.	
Backup Battery	Rechargeable Li-ion battery: 3.7V, 60 mAh Data retention for 30 minutes Charging time: 4 hours	

Power Adaptor

Power Supply Cord with Universal Power Adaptor	Input	AC 100~240 V, 50/60 Hz
	Output	DC 5V, 2A

Working Time

Supports working time for at least 10 hours at 25 degrees

PHYSICAL CHARACTERISTICS

Color Touch Screen Display

Display	4.66", 16.7M color, HD (outdoor viewable, optically bonded to Touch Panel), Asahi Dragontrail
Resolution	HD (720x 1280 pixels)

Notifications

Status LED	2 LEDs: one Tri-color LED + one Bi-color LED
Audio	Integrated with one speaker, dual array digital microphones with echo and noise cancellation, HD voice support

Dimensions & Weight

Dimensions	163 mm (L) x 78mm (W) x 19mm (H)
Weight	Under 360 g (2D Reader, including battery)

ENVIRONMENTAL CHARACTERISTICS

Temperature

Operating	-20°C to 50°C
Storage	-30°C to 70°C
Charging	0°C to 35°C

Humidity

Operating	5% to 85% (non-condensing)
-----------	----------------------------

Resistance

Impact Resistance	Multiple drops onto concrete at 1.5 m on all six sides
Tumble Test	1000 times at 1m per applicable IEC tumble specifications
Electrostatic Discharge	±15 kV air discharge, ±8 kV contact discharge

PROGRAMMING SUPPORT

Development Environment & Tools

JAVA	Environment Android studio Software Development Kit: JAR
C#	Environment: Visual Studio Software Development Kit: DLL (Xamarin Library)

Software & Utilities

Software Package	<ul style="list-style-type: none">▶ Reader Configuration▶ Software Trigger Key▶ Programmable Keys▶ WMDS Server▶ ADC Client▶ App Lock▶ HF RFOD Config
------------------	--

CE Declaration of Conformity

For the following equipment:
Mobile Computer

(Product Name)

RS51

(Model Designation)

is herewith confirmed to comply with the requirements set out in the Council Directive on the Approximation of the Laws of the Member States relating to Electromagnetic Compatibility of Radio Equipment Directive (2014/53/EU). For the evaluation regarding the Directives, the following standards were applied:

EN 300 328 V2.1.1

EN 301 511 V12.5.1

EN 301 908-2 V11.1.2

EN 301 908-13 V11.1.2

EN 50360 :2001 A1:2012

EN 55024 : 2010 +A1:2015

EN 55032: 2015+AC:2016

EN 60950-1 : 2006+A2:2013

EN301 489-1 V2.1.1

Final draft EN301 489-3 V2.1.1

EN301 489-17 V3.1.1

EN 300330 V2.1.1

EN 50566:2013 AC:2014

EN 303 413 V1.1.1

EN 301 908-1 V11.1.1

EN 62479:2010

EN 61000-3-2 :2014

EN 61000-3-3 :2013

EN 301 893 V2.1.1

Draft EN301 489-52 V1.1.0

Draft EN 301 489-19 V2.1.0

The following importer/manufacturer is responsible for this declaration:

(Company Name, Importer)

(Company Address, Importer)

Person responsible for this declaration:

(Name, Surname, Importer)

(Position/Title)

(Legal Signature)

(Place)

(Date)

CIPHERLAB CO.

(Company Name, Manufacturer)
12F, 333 Dunhua S. Rd., Sec.2, Taipei,
Taiwan R.O.C

(Company Address, Manufacturer)

Person responsible for this declaration:

Herbie Jiang

(Name, Surname, Manufacturer)

Manager

(Position/Title)

(Legal Signature)

Taiwan

(Place)

2017/6/13

(Date)

Object of the declaration:



I the undersigned, hereby declare that the equipment specified above conforms to the above Directive(s) and Standard(s).

The Notified Body Telefication B.V., with Notified Body number 0560 performed: choose applicable Modules: B+C

Where applicable:

The issued EU-type examination certificate: note certificate number