



CHAPTER 2

Installing the Access Point

This chapter describes how to install the 1552 access point and contains the following sections:

- [Unpacking the Access Point, page 2-2](#)
- [Tools and Hardware, page 2-2](#)
- [Warnings, page 2-4](#)
- [Safety Information, page 2-5](#)
- [Avoiding Damage to Radios in a Testing Environment, page 2-7](#)
- [Installation Guidelines, page 2-8](#)
- [Installing the Access Point, page 2-15](#)
- [Grounding the Access Point, page 2-34](#)
- [Connecting a Fiber-Optic Cable to the Access Point, page 2-35](#)
- [Powering the Access Point, page 2-38](#)
- [Installing the Access Point in Hazardous Locations, page 2-53](#)

Unpacking the Access Point

When you are unpacking the access point, do not remove the foam blocks attached to the antenna connectors. The foam protects the antenna connectors during installation.

To unpack the access point, follow these steps:

-
- Step 1** Open the shipping container and carefully remove the contents.
 - Step 2** Return all packing materials to the shipping container, and save it.
 - Step 3** Ensure that all items listed in “[Package Contents](#)” are included in the shipment. If any item is damaged or missing, notify your authorized Cisco sales representative.
-

Package Contents

The typical access point package contains the following items:

- Access point
- Cisco product documentation and translated safety warnings
- Three liquid-tight adapters
- Two-pin DC power connector
- Ground lug (Panduit PLCD6-10A-L) and screws with lock washers
- Watertight cable glands for Power-over-Ethernet (PoE) ports (depending on the 1552 access point model, 2 or 3 cable glands are provided)

Tools and Hardware

The tools and hardware used to install the 1552 access point are described in:

- [Optional Tools and Hardware, page 2-2](#)
- [Optional Tools and Hardware That You Supply, page 2-3](#)
- [Pole Installation Hardware and Tools, page 2-3](#)
- [Cable Strand Installation Hardware and Tools, page 2-4](#)

Optional Tools and Hardware

The optional tools and hardware that can be obtained from Cisco are:

- Optional power injector (AIR-PWRINJ1500-2=)
- Optional AC power cord
 - 40-ft (12.2-m) power cord with North American plug (AIR-CORD-R3P-40NA=) for light pole installations in the US and Canada
 - AC power cord, 40 ft (12.2 m) with European unterminated end (AIR-CORD-R3P-40UE=) for light pole installations outside of the US and Canada

- 4-ft (1.2-m) streetlight power tap adapter (AIR-PWR-ST-LT-R3P=) for light pole installations in the US and Canada
- Antennas, 2.4/5-GHz (refer to the [“Antenna Configurations”](#) section on page 1-12)
- Optional battery backup unit (AIR-1520-BATT-6AH=)—Used only on model 1552E
- Optional pole mount kit (AIR-ACCPMK1550=)
- Optional strand mount kit (AIR-ACCSMK1550=)
- Optional banding strap tool (BAND IT) (AIR-BAND-INST-TL=)
- Optional fiber-optic 100BASE-BX10-U SFP, fiber-optic take-up reels, and liquid-tight adapter (GLC-FE-100BX-URGD=)

Optional Tools and Hardware That You Supply

Tools and materials that are user-supplied are:

- Ground lug crimping tool (Panduit CT-720 with CD-720-1 die)
- 6-AWG copper ground wire
- 13 mm box-end wrench or socket set
- Adjustable wrench, 22 mm socket, or Sealcon S-2200-WR socket wrench
- #8 Torx screwdriver
- Small flat screwdriver for DC power connector
- Optional shielded outdoor-rated Ethernet (CAT5e or better) cable with 0.20 to 0.35 in (0.51 to 0.89 cm) diameter
- Optional Ethernet RJ-45 connector and installation tool
- Optional shielded outdoor-rated DC power cable with 0.20 to 0.35 inch (.051 to 0.89 cm) diameter
- Optional cable F-connector adapter (stinger)
- Optional ground rod, as required by local regulations
- Optional ladder, power lift, rope, or other tools as required

Pole Installation Hardware and Tools

To install the access point on a vertical or horizontal metal, wood, or fiberglass pole, you need the following additional hardware and tools:

- Pole mount kit (AIR-ACCPMK1550=)
 - Pole clamp bracket
 - Two gusset strap brackets
 - One mounting bracket
 - Twelve hex bolts (M8 x16)
 - One M8 flange nut
 - Six M8 flat washers
 - Ten M8 split lock washers

- Two stainless steel mounting straps
- Customer banding strap tool (BAND IT)—(AIR-BAND-INST-TL=)
- Customer-supplied 13-mm and box-end wrench or socket set
- Customer-supplied adjustable wrench, 22 mm socket, or Sealcon S-2200-WR socket wrench

Cable Strand Installation Hardware and Tools

To install the access point on a cable strand, you need the following additional parts:

- Cable strand mount kit (AIR-ACCSMK1550=)
 - Four hex bolts (M8, 0x16mmL)
 - Four M8 split lock washers (0.14 8mmOD, 2mmT)
 - Four M8 flat washers (16.0mmOD, 1.6mmT)
 - Two carriage bolt fasteners (5/16-18 x 1.25 in.)
 - Six hex nuts, serrated flange (5/16-18)
 - Four carriage bolts (5/16 x 5/8LG)
 - Strand mounting brackets—1 left bracket, 1 right bracket, 2 adjustable brackets
 - Four strap clamps
- Customer-supplied 13-mm box-end wrench or socket set
- Customer-supplied adjustable wrench, 22 mm socket, or Sealcon S-2200-WR socket wrench

Warnings

Translated versions of all safety warnings are available in the safety warning document that shipped with your access point or on Cisco.com. To browse to the document on Cisco.com, refer to [Appendix A, “Translated Safety Warnings”](#) for instructions.



Warning

IMPORTANT SAFETY INSTRUCTIONS

This warning symbol means danger. You are in a situation that could cause bodily injury. Before you work on any equipment, be aware of the hazards involved with electrical circuitry and be familiar with standard practices for preventing accidents. Use the statement number provided at the end of each warning to locate its translation in the translated safety warnings that accompanied this device.

Statement 1071

SAVE THESE INSTRUCTIONS



Warning

This equipment is to be installed by trained and qualified personnel, as per these installation instructions. The installer is responsible for obtaining any required local or national safety inspections of the structural integrity of the installation by the local authority/inspection department.



Warning

Do not operate the unit near unshielded blasting caps or in an explosive environment unless the device has been modified to be especially qualified for such use. Statement 364

**Warning**

The cables specified in this installation guide that are used with the specified liquid-tight adapters provide protection against ingress of moisture for a Type 4/IP67 classified enclosure. If substitute cable are used, the installer must ensure that the size (OD) of the cable meets the acceptable range allowed by the liquid-type adaptor.

**Warning**

This equipment must be externally grounded using a customer-supplied ground wire before power is applied. Contact the appropriate electrical inspection authority or an electrician if you are uncertain that suitable grounding is available. Statement 366

**Warning**

Read the installation instructions before connecting the system to the power source. Statement 1004

**Warning**

Ultimate disposal of this product should be handled according to all national laws and regulations. Statement 1040

Safety Information

Follow the guidelines in this section to ensure proper operation and safe use of the access point.

FCC Safety Compliance Statement

The FCC, with its action in ET Docket 96-8, has adopted a safety standard for human exposure to RF electromagnetic energy emitted by FCC-certified equipment. When used with approved Cisco Aironet antennas, Cisco Aironet products meet the uncontrolled environmental limits found in OET-65 and ANSI C95.1, 1991. Proper operation of this radio device according to the instructions in this publication results in user exposure substantially below the FCC recommended limits.

Safety Precautions

**Warning**

In order to comply with radio frequency (RF) exposure limits, the antennas for this product should be positioned no less than 6.56 ft (2 m) from your body or nearby persons. Statement 339

**Warning**

The AC power supply has double pole/neutral fusing. Statement 188

**Warning**

Do not work on the system or connect or disconnect cables during periods of lightning activity. Statement 1001

**Warning****Class 1 laser product.** Statement 1008**Warning****There is the danger of explosion if the battery is replaced incorrectly. Replace the battery only with the same or equivalent type recommended by the manufacturer. Dispose of used batteries according to the manufacturer's instructions.** Statement 1015**Warning****A readily accessible two-poled disconnect device must be incorporated in the fixed wiring.** Statement 1022**Warning****To reduce the risk of fire, use only No. 26 AWG or larger telecommunication line cord.** Statement 1023**Warning****This unit might have more than one power supply connection. All connections must be removed to de-energize the unit.** Statement 1028**Warning****Only trained and qualified personnel should be allowed to install, replace, or service this equipment.** Statement 1030**Warning****Connect the unit only to DC power source that complies with the safety extra-low voltage (SELV) requirements in IEC 60950 based safety standards.** Statement 1033**Warning****When installing or replacing the unit, the ground connection must always be made first and disconnected last.** Statement 1046.**Warning****Do not locate the antenna near overhead power lines or other electric light or power circuits, or where it can come into contact with such circuits. When installing the antenna, take extreme care not to come into contact with such circuits, because they may cause serious injury or death. For proper installation and grounding of the antenna, please refer to national and local codes (for example, U.S.:NFPA 70, National Electrical Code, Article 810, Canada: Canadian Electrical Code, Section 54).** Statement 1052**Caution**

Before connecting or disconnecting a power cord, you must remove AC power from the power cord using a suitable service disconnect.

For additional important safety instructions for AC power cords, refer to the *AC Power Cords for Cisco Aironet 1550 Series Outdoor Mesh Access Points* document that shipped with your AC power cords.

For safety and to achieve a good installation, please read and follow these safety precautions:

- Select your installation site with safety, as well as performance in mind. Remember: electric power lines and phone lines look alike. For safety, assume that any overhead line can kill.
- Call your electric power company. Tell them your plans, and ask them to come look at your proposed installation.
- Plan your installation carefully and completely before you begin. Successful raising of a mast or tower is largely a matter of coordination. Each person should be assigned to a specific task and should know what to do and when to do it. One person should be in charge of the operation to issue instructions and watch for signs of trouble.
- When installing the access point and antennas, remember:
 - Do not use a metal ladder.
 - Do not work on a wet or windy day.
 - Do dress properly—shoes with rubber soles and heels, rubber gloves, long sleeved shirt or jacket.
- Use a rope to lift the access point. If the assembly starts to drop, get away from it and let it fall.
- If any part of the antenna system should come in contact with a power line, do not touch it or try to remove it yourself. Call your local power company. They will remove it safely.

If an accident should occur, call for qualified emergency help immediately.

Avoiding Damage to Radios in a Testing Environment

The radios on outdoor units (bridges) have higher transmit power levels than radios on indoor units (access points). When you test high-power radios in a link, you must avoid exceeding the maximum receive input level for the receiver. At levels above the normal operating range, packet error rate (PER) performance is degraded. At even higher levels, the receiver can be permanently damaged. To avoid receiver damage and PER degradation, you can use one of the following techniques:

- Separate the omnidirectional antennas by at least 2 ft (0.6 m) to avoid receiver damage or by at least 25 ft (7.6 m) to avoid PER degradation.



Note These distances assume free space path loss and are conservative estimates. Required separation distances for damage and performance degradation levels in actual deployments are less if conditions are not non-line-of-sight.

- Reduce the configured transmit power to the minimum level.
- Use directional antennas, and keep them away from each other.
- Cable the radios together using a combination of attenuators, combiners, or splitters to achieve a total attenuation of at least 60 dB.

For a radiated test bed, the following equation describes the relationships among transmit power, antenna gain, attenuation, and receiver sensitivity:

$$\text{txpwr} + \text{tx gain} + \text{rx gain} - [\text{attenuation due to antenna spacing}] < \text{max rx input level}$$

Where:

txpwr = Radio transmit power level

tx gain = transmitter antenna gain

rx gain = receiver antenna gain

For a conducted test bed, the following equation describes the relationships among transmit power, antenna gain, and receiver sensitivity:

$$txpwr - [\text{attenuation due to coaxial components}] < \text{max rx input level}$$

**Caution**

Under no circumstances should you connect the antenna port from one access point to the antenna port of another access point without using an RF attenuator. If you connect antenna ports, you must not exceed the maximum survivable receive level of 0 dBm. Never exceed 0 dBm, or damage to the access point can occur. Using attenuators, combiners, and splitters having a total of at least 60 dB of attenuation ensures that the receiver is not damaged and that PER performance is not degraded.

Installation Guidelines

Because the access point is a radio device, it is susceptible to common causes of interference that can reduce throughput and range. Follow these basic guidelines to ensure the best possible performance:

- For information on planning and initially configuring your Cisco Mesh network, refer to the *Cisco Wireless Mesh Access Points, Design and Deployment Guide, Release 7.0*.
- Review the FCC guidelines for installing and operating outdoor wireless LAN devices at http://www.cisco.com/en/US/partner/prod/collateral/routers/ps272/data_sheet_c78-647116_ps11451_Products_Data_Sheet.html.
- Perform a site survey before beginning the installation.
- Install the access point in an area where structures, trees, or hills do not obstruct radio signals to and from the access point.
- The access points can be installed at any height, but best throughput is achieved when all the access points are mounted at the same height. We recommend installing the access points no higher than 40 feet to allow support for wireless clients on the ground.

**Note**

To calculate path loss and to determine how far apart to install access points, consult an RF planning expert.

Site Surveys

Every network application is a unique installation. Before installing multiple access points, you should perform a site survey to determine the optimum use of networking components and to maximize range, coverage, and network performance.

Consider the following operating and environmental conditions when performing a site survey:

- Data rates—Sensitivity and range are inversely proportional to data bit rates. The maximum radio range is achieved at the lowest workable data rate. A decrease in receiver sensitivity occurs as the radio data increases.
- Antenna type and placement—Proper antenna configuration is a critical factor in maximizing radio range. As a general rule, range increases in proportion to antenna height. However, do not place the antenna higher than necessary, because the extra height also increases potential interference from other unlicensed radio systems and decreases the wireless coverage from the ground.
- Physical environment—Clear or open areas provide better radio range than closed or filled areas.

- Obstructions—Physical obstructions such as buildings, trees, or hills can hinder performance of wireless devices. Avoid locating the devices in a location where there is an obstruction between the sending and receiving antennas.

Before Beginning the Installation

Before you begin the installation process:

- Ensure that a site survey has been performed.
- Ensure that your network infrastructure devices are operational and properly configured.
- Ensure that your controllers are connected to switch trunk ports.
- Ensure that your switch is configured with untagged access ports for connecting your access points.
- Ensure that a DHCP server with Option 43 configured is reachable by your access points, or manually configure the controller information in the access point (for additional information, refer to the [“Configuring DHCP Option 43” section on page F-1](#)).
- Become familiar with the access point installation components (see the [“Becoming Familiar with Access Point Installation Components” section on page 2-9](#)).

Becoming Familiar with Access Point Installation Components

The access point is designed to be installed in an outdoor environment, such as the exterior roof overhang of a tall building or a streetlight pole. Carefully review the following figures to become familiar with the system components, connectors, indicators, cables, system interconnection, and grounding:

- Components in a typical access point installation (see [Figure 2-1](#))
- Pole mount installation (see [Figure 2-2](#))
- Cable strand mount installation (see [Figure 2-3](#))
- Streetlight power tap installation (see [Figure 2-4](#))



Note

The illustrations in this document show all available connections for the access point. Unused connections are capped with a connector plug to ensure the watertight integrity of the access point. liquid-tight adapters are provided for connector openings, which can be installed before or after deploying the access point.

Figure 2-1 Components in a Typical Access Point Installation

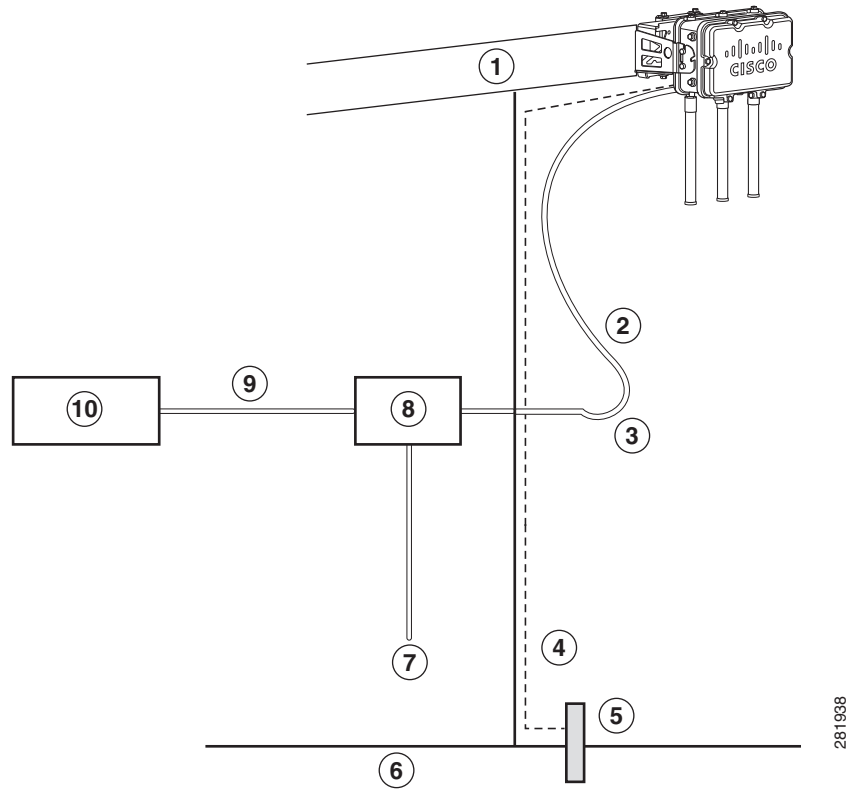

| | | | |
|---|--|----|--|
| 1 | Building roof-overhang | 6 | Ground |
| 2 | Shielded outdoor-rated Ethernet (CAT5e or better) cable ¹ | 7 | AC power cord ² |
| 3 | Water drip loop | 8 | Power injector ³ |
| 4 | 6-AWG copper grounding wire ¹ | 9 | Shielded Ethernet (CAT5e or better) cable ¹ |
| 5 | Ground rod ¹ | 10 | Controller (through a switch) |

1. User supplied.
2. The safety ground wire in the AC power cord must have a ground path to a grounding rod.
3. The shielded Ethernet cable has a ground path through the power injector and the safety ground wire in the AC power cord.

Note

The 1552 access point was designed with consideration for resistance to effects of lightning effects on the access point electronics. The 1552 access point employs lightning arrestor circuitry on the Ethernet and power ports. On the input Ethernet port, Gas Discharge Tubes (GDT) are used for the Power Entry Module (PEM) to mitigate lightning effect. On the AC power, GDTs are also used along with fuses to mitigate high-current condition. For the DC power, a fuse is used to mitigate high current condition.

While not a common practice, the user may want to consider using lightning protection at the antenna ports for added protection. To meet EN/IEC60950-22 (Clause 4.2) requirements, the installer must ensure that additional protection is provided external to this equipment to reduce transient surges from Overvoltage IV to Overvoltage Category II at the AC power input of the access point. The over-voltage and fault-current protection components used to achieve this protection must comply with the IEC 61643

series of standards. To meet CAN/CSA-C22.2 No. 60950-22-07/UL60950-22 requirements, the installer may use alternative components to provide this additional protection. Those components may comply with ANSI/IEEE C62.11, CSA Certification Notice No. 516, CSA C22.2 No. 1, or UL 1449. Suitability of the components for the application must be determined for the intended installation. (For example, some devices are suitable for installation on the load side of the service entrance only, and some are suitable for use with cord-connected equipment only.)



Warning

Installation of the equipment must comply with local and national electrical codes. Statement 1074

Figure 2-2 Pole Mount Installation

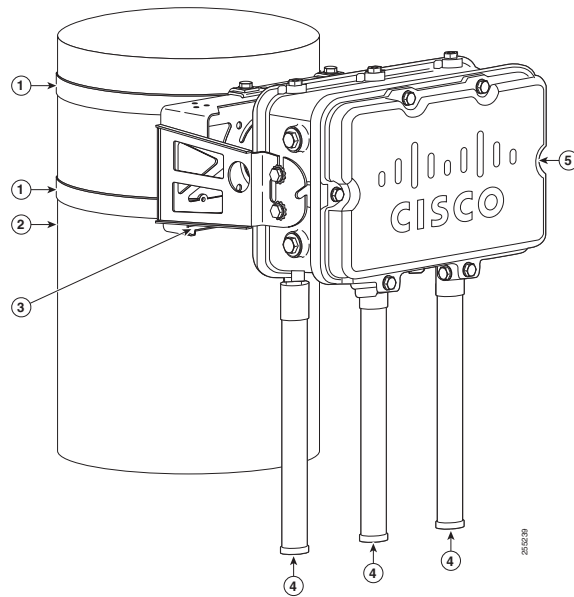

| | | | |
|----------|---|----------|--|
| 1 | Stainless steel mounting straps (part of pole mount kit) | 4 | Cisco Aironet Dual-Band Omnidirectional Antennas. The dual-band antenna covers both the 2.4 GHz and 5 GHz bands. |
| 2 | Pole (wood, metal, or fiberglass) 2 to 16 in. (5.1 to 40.6 cm) diameter | 5 | 1552 series access point, models: <ul style="list-style-type: none"> • AIR-CAP1552E-x-K9, or • AIR-CAP1552H-x-K9 |
| 3 | Mounting bracket (part of pole mount kit) | | |

Figure 2-3 Cable Strand Mounting Example - Shown on a 1552 Model AIR-CAP1552C-x-K9

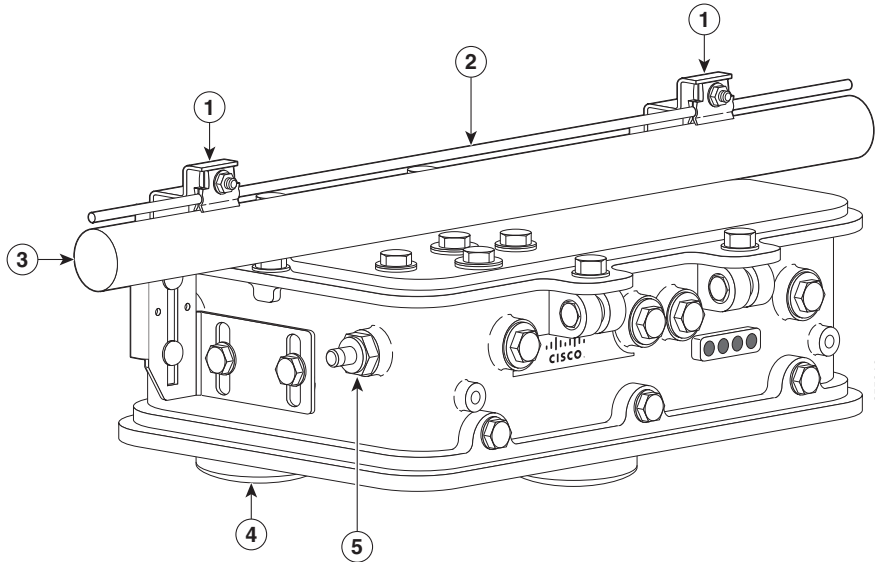

| | | | |
|----------|------------------------------------|----------|---|
| 1 | Cable Strand Mounting Kit brackets | 4 | Low-profile dual-band (2.4 GHz and 5 GHz) 3-element array antenna unit |
| 2 | Strand support cable | 5 | F-connector adapter for the POC cable (<u>only</u> on model AIR-CAP1552C-x-K9) |
| 3 | Cable bundle | | |

Figure 2-4 Streetlight Power Tap Adapter Installation

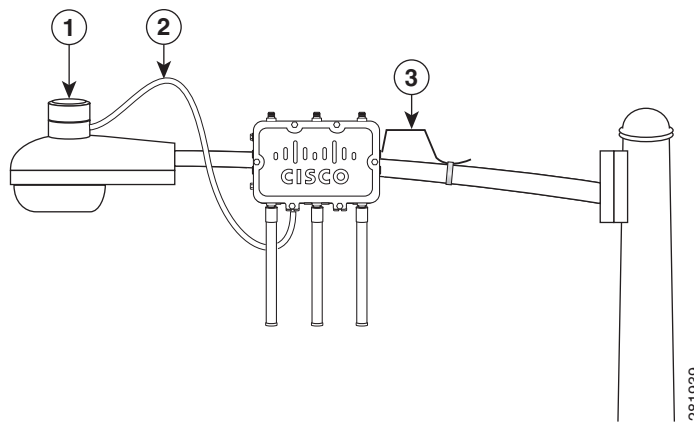

| | | | |
|----------|-------------------------------|----------|-----------------------------|
| 1 | Outdoor light control | 3 | 6-AWG copper grounding wire |
| 2 | Streetlight power tap adapter | | |

Antenna N-Type Connector Locations

The access point antenna N-type connectors are located on the bottom of Models AIR-CAP1552E-x-K9 and AIR-CAP1552H-x-K. The N-type connectors support the Cisco Aironet AIR-ANT2547V-N Dual-Band Omnidirectional Antennas. Figure 2-5 shows the antenna port locations viewed from the RF cover side.

Figure 2-5 Antenna Port Locations - Models AIR-CAP1552E-x-K9 and AIR-CAP1552H-x-K9

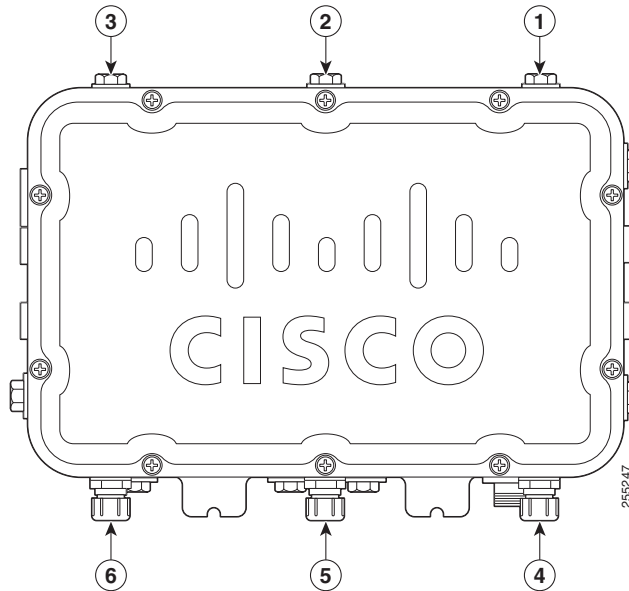

| | | | |
|---|----------|---|----------------------------|
| 1 | Not used | 4 | Antenna port 4 (with caps) |
| 2 | Not used | 5 | Antenna port 5 (with caps) |
| 3 | Not used | 6 | Antenna port 6 (with caps) |

Adding the Access Point MAC Addresses to the Controller Filter List

Before installing your access points, configure your controller by adding the MAC addresses of the access points to the filter list. MAC address filtering is enabled by default. This enables the controller to respond to the listed access points. To add a MAC filter entry on the controller, follow these steps:

- Step 1** Log into your controller using a web browser.
- Step 2** Choose **SECURITY > MAC Filtering > New**.
- Step 3** Enter the MAC address of the access point to the MAC Filter list; for example, 00:0B:91:21:3A:C7.



Note The access point MAC address is located on the bottom of the unit. When two MAC addresses are shown, use the top MAC address.

- Step 4** Select a WLAN ID or **Any WLAN** from the WLAN ID pop-up menu.

- Step 5** Enter a description (32 characters maximum) of the access point in the Description field; for example, Fisher_Street_00.0B.91.21.3A.C7 shows the location and MAC address of the access point.
 - Step 6** Choose an interface from the Interface Name pop-up menu, and click **Apply**.
 - Step 7** Repeat Steps 2 to 6 to add other access points to the list.
 - Step 8** Log out of your controller, and close your web browser.
-

Configuring a RAP

The access point defaults to the mesh access point (MAP) radio role. One or more of your access points must be reconfigured as a root access point (RAP). The RAPs connect to a wired Ethernet link through a switch to the controller. The MAPs use their wireless backhaul interface to connect to a RAP to reach the controller.

To configure a RAP on the controller GUI, follow these steps:

- Step 1** Log into your controller using a web browser.
 - Step 2** Click **Wireless**. When your access point associates to the controller, the name of the access point appears in the AP Name list.
 - Step 3** Double-click your access point name.
 - Step 4** Find Mesh Information, and choose **Root AP** by clicking the drop-down arrow in the AP Role field.
 - Step 5** Click **Apply**.
 - Step 6** Repeat Steps 2 through 5 for each RAP.
 - Step 7** Log out from your controller, and close your web browser.
-

Configuring a Bridge Group Name

The bridge group name (BGN) controls the association of the access points to a RAP. BGNs can be used to logically group the radios to avoid different networks on the same channel from communicating with each other. This setting is also useful if you have more than one RAP in your network in the same area.

If you have two RAPs in your network in the same area (for more capacity), we recommend that you configure the two RAPs with the same BGN, but on different channels.

The BGN is a string of ten characters maximum. A factory-set bridge group name (NULL VALUE) is assigned during manufacturing. It is not visible to you, but allows new access point radios to join a network of new access points. The BGN can be reconfigured from the Controller CLI and GUI. After configuring the BGN, the access point reboots.

The BGN should be configured very carefully on a live network. You should always start from the farthest node (last node) from the RAP and move towards the RAP. If you start configuring the BGN in a different location, then the access points beyond this point (farther away) are dropped, as they have a different BGN.

To configure the BGN for the access points using the GUI, follow these steps:

-
- Step 1** Log into your controller using a web browser.
 - Step 2** Click **Wireless**. When access points associates to the controller, the name of the access point appears in the AP Name list.
 - Step 3** Double-click on an access point name.
 - Step 4** Find Mesh Information, and enter the new BGN in the Bridge Group Name field.
 - Step 5** Click **Apply**.
 - Step 6** Repeat Steps 2 through 5 for each access point.
 - Step 7** Log out from your controller, and close your web browser.
-

Installing the Access Point

This section provides instructions for installing your access points. Personnel installing the access point must understand wireless access points and bridging techniques and grounding methods.



Caution

All installation methods for mounting an access point on any wall surface is subject to the acceptance of local jurisdiction.

Installation Options

There are two optional installation kits:

- Pole mount kit—Used for pole, wall, or streetlight installations
- Strand mount kit—Used for cable strand installations



Warning

Only trained and qualified personnel should be allowed to install, replace, or service this equipment. Statement 1030



Warning

Installation of the equipment must comply with local and national electrical codes. Statement 1074



Caution

To provide inline PoE, you must use the power injector (AIR- PWRINJ1500-2=) specified for the access point. Other power injectors, PoE switches, and 802.3af power sources do not provide adequate power, which might cause the access point to malfunction and cause over-current conditions at the power source. You must ensure that the switch port connected to the access point has PoE turned off.

Refer to these sections for installation details:

- [Access Point Mounting Orientation](#), page 2-16
- [Mounting the Access Point on a Wall](#), page 2-16
- [Mounting the Access Point on a Pole](#), page 2-19
- [Cable Strand Mounting](#), page 2-26

Access Point Mounting Orientation

When mounting an access point on a horizontal or vertical surface, you must ensure that the access point is oriented with the LED indicators pointing down (see [Figure 2-2](#), [Figure 2-3](#), and [Figure 2-4](#)). This positioning allows the LEDs to be visible to someone on the ground below the access point.

You must also ensure the access point is mounted with the hinged access cover facing out.



Note

Omnidirectional antennas are vertically polarized and should be mounted vertically with the antennas facing down.

Mounting the Access Point on a Wall

The optional pole mount kit contains a mounting bracket for wall mounting. You can use the mounting bracket as a template to mark the positions of the mounting holes for your installation. You then install the mounting plate, and attach the access point when you are ready. [Table 2-1](#) lists the material that you will need to provide in addition to the pole mount kit.

Table 2-1 *Material Needed to Mount Access Point to a Vertical Wall*

| Materials Required | In Kit |
|--|--------|
| • Ground lug and screws (provided with access point) | Yes |
| • Crimping tool for ground lug, Panduit CT-720 with CD-720-1 die (http://onlinecatalog.panduit.com) | No |
| • Four M8 or 5/16 in. (31 mm) screws | No |
| • Four wall anchors (specified for wall material) | No |
| • Drill bit for wall anchors | No |
| • Electric drill and standard screwdriver | No |
| • #6-AWG ground wire | No |
| • Shielded outdoor-rated Ethernet (CAT5e or better) cable | No |
| • Grounding block | No |
| • Grounding rod | No |
| • 13-mm box-end wrench or socket set | No |

**Caution**

The mounting surface, attaching screws, and optional wall anchors must be able to support a 50-lb (22.7 kg) static weight.

To mount the access point on a vertical wall, follow these instructions:

Step 1

Use the mounting bracket as a template to mark four screw hole locations on your mounting surface. See [Figure 2-6](#) for the mounting bracket screw hole locations. You can optionally use the individual mounting holes or the mounting slots.

**Caution**

The mounting surface, attaching screws, and optional wall anchors must be able to support a 50-lb (22.7 kg) static weight.

Figure 2-6 Mounting Bracket for Wall Mounting

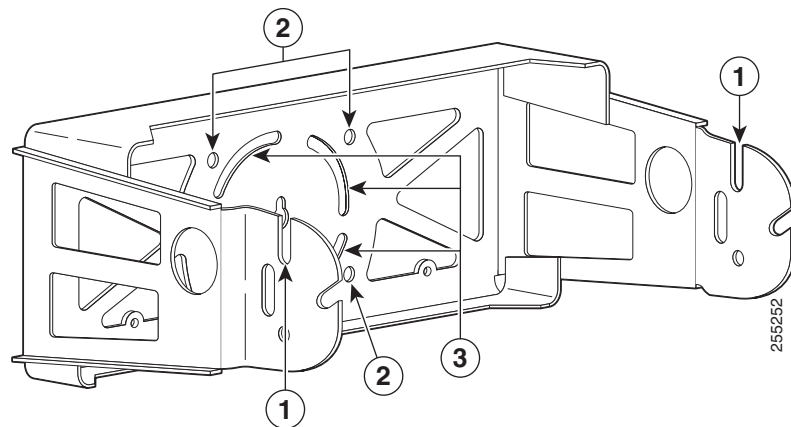

| | | | |
|----------|--------------------------------|----------|--|
| 1 | Access point quick mount notch | 3 | Mounting slots (allows bracket rotation) |
| 2 | Mounting holes | | |

Step 2

Use four customer-supplied screws and optional screw anchors to attach the mounting plate to the mounting surface.

**Note**

If necessary, use suitable screw anchors and an exterior-grade plywood backboard to mount the access point to stucco, cement, or drywall.

- Step 3** Screw a M8 x16 bolt in the top support bolt hole on each side the access point (see [Figure 2-7](#)). Do not screw the bolt all the way in; leave approximately a 0.25 inch (0.635 cm) space.

Figure 2-7 Location of Access Point Top Support Bolt Hole

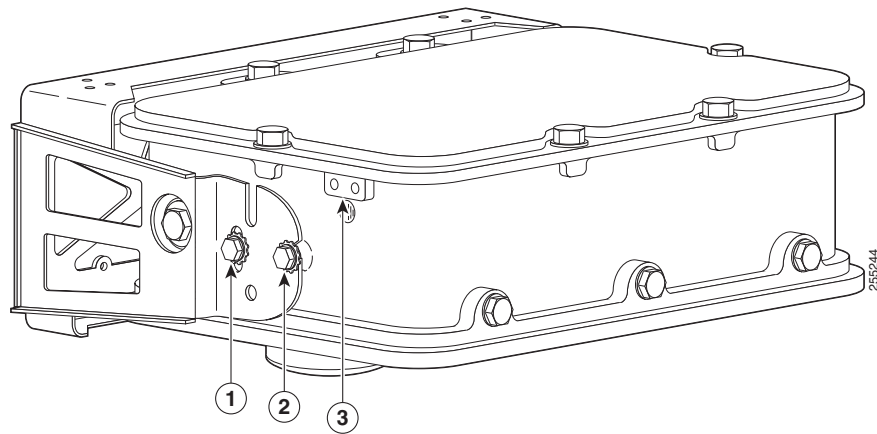

| | | | |
|----------|--|----------|---------------------|
| 1 | M8 x16 bolt (supplied with pole mount kit) | 3 | Ground lug location |
| 2 | M8 x16 bolt (supplied with pole mount kit) | | |

- Step 4** Position the two bolts on the access point into the quick mount notches on each side of the mounting bracket (see [Figure 2-2](#)). Ensure that the hinged door is facing out.
- Step 5** Screw a M8 x16 bolt (with flat and lock washers) into the second bolt hole on each side of the access point.
- Step 6** Ensure that the front of the access point is vertical, and tighten the four bolts to 13 to 15 ft lbs (17.6 to 20.3 Nm).
- Step 7** When using the Cisco Aironet Dual-Band Omnidirectional Antennas, connect them to the access point as shown in [Figure 2-2](#). Hand-tighten the antennas to the access point.
- Step 8** Continue with the “[Grounding the Access Point](#)” section on page 2-34 and the “[Powering the Access Point](#)” section on page 2-38.

Mounting the Access Point on a Pole

When installing an access point on a vertical pole, mast, or a streetlight pole, you should use the optional Cisco pole mount kit. The kit supports metal, wood, or fiberglass poles from 2 to 16 inches in diameter.

Assembling the Pole Clamp Bracket and the Mounting Bracket

When installing an access point on a pole, mast, or a streetlight, you should use the optional Cisco pole mount kit. The kit supports metal, wood, or fiberglass poles from 2 to 16 inches in diameter.

The pole mount kit contains several parts that you must assemble prior to mounting on a pole. First you need to assemble two strap brackets on the pole clamp bracket that are positioned for the pole diameter you are using to mount the access point. [Figure 2-8](#) illustrates the pole diameter indicators and bolt holes on the pole clamp bracket.

Figure 2-8 Pole Clamp Bracket Adjustment Hole Locations

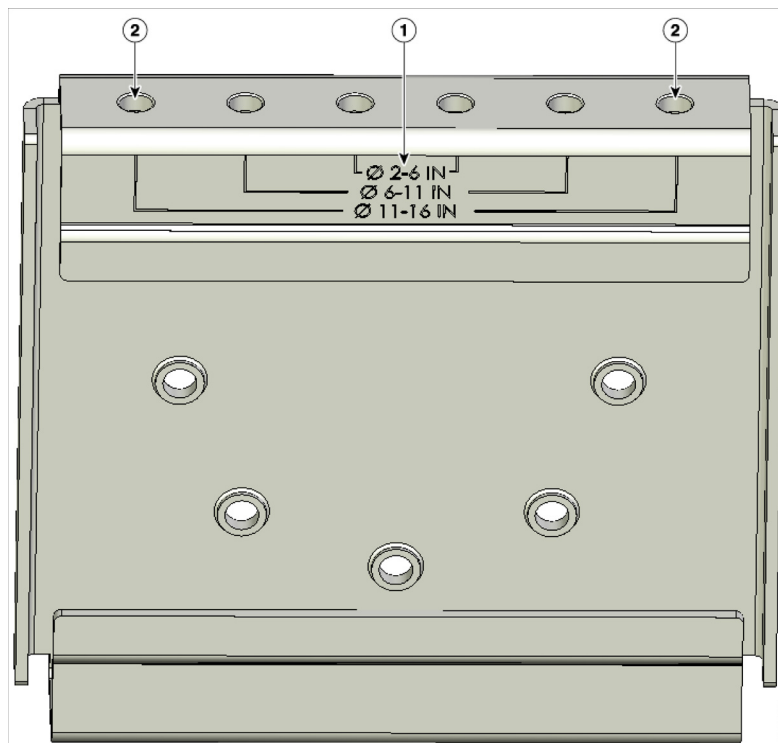

| | | | |
|----------|--|----------|---|
| 1 | Pole size indicators <ul style="list-style-type: none"> • 2 to 6 in. • 6 to 11 in. • 11 to 16 in. | 2 | Bolt holes for pole diameters (11 to 16 inches indicated) |
|----------|--|----------|---|

To assemble the pole clamp bracket, follow these steps:

Step 1 Position the strap brackets on the pole clamp bracket for the pole diameter you are using and secure each strap bracket with two M8 x16 bolts (with lock washers) (see [Figure 2-9](#)). Tighten the bolts to 13 to 15 ft lbs (17.6 to 20.3 Nm).

Figure 2-9 Assembled Pole Clamp Bracket and Strap Brackets

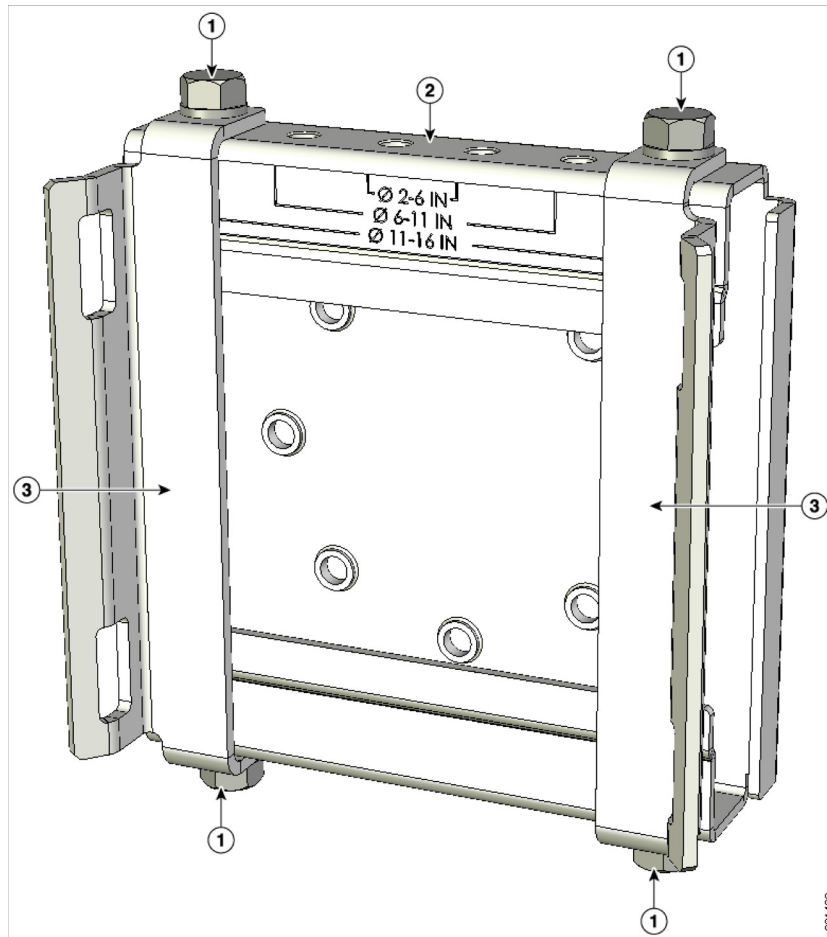

| | | | |
|----------|---------------------------------------|----------|--|
| 1 | M8 x1.25x16 bolts (with lock washers) | 3 | Strap bracket (shown positioned for 11 to 16 inch diameter pole) |
| 2 | Pole clamp bracket | | |

Step 2 Screw the M8 nut onto the pole clamp bracket support bolt, and tighten just enough to prevent the bolt from falling off.

Step 3 Go to the [“Pole Mounting”](#) section on page 2-21.

Pole Mounting

The access point can be installed where power is available, without the need for a wired LAN connection. The access point uses intelligent wireless routing that is based on the Adaptive Wireless Path Protocol (AWPP). AWPP enables a remote access point to dynamically optimize the best route to the wired LAN network using another access point.

The 1522 access point uses the 5-GHz radio for the Mesh backhaul and connections. The 2.4-GHz radio is used for local wireless client access.

To mount your access point on a vertical pole or streetlight pole, you need to install two metal bands around the pole to support the access point. This process requires extra tools and material not provided in the pole mount kit (see [Table 2-2](#)).

Table 2-2 Material Needed to Mount Access Point on a Pole

| Mounting Method | Materials Required | In Kit |
|------------------------------|--|--------|
| Vertical or streetlight pole | • Two 0.75-in (1.9 cm) stainless steel bands | Yes |
| | • Banding strap tool (BAND IT) (Cisco AIR-BAND-INST-TL=) | No |
| | • Ground lug (provided with access point) | Yes |
| | • Crimping tool for ground lug, Panduit CT-720 with CD-720-1 die (http://onlinecatalog.panduit.com) | No |
| | • #6 AWG ground wire | No |

To mount the access point onto a vertical pole or streetlight pole, follow these steps:

- Step 1** Select a mounting location on the pole to mount the access point. You can attach the access point to any pole from 2 to 16 inch (5.1 to 40.6 cm) in diameter.



Note If you will be using a streetlight power tap adapter, position the access point within 3 ft (1 m) of the outdoor light control.

- Step 2** For poles larger than 3.5 inch (8.9 cm), mount the pole clamp bracket assembly to a pole (see [Figure 2-10](#)) using two metal straps. Following the instructions provided with the banding strap tool (BAND IT) (AIR-BAND-INST-TL=), loop each metal strap twice through the slots on the strap bracket.



Caution

Do not place the metal straps in the large open area between the pole clamp bracket and the strap brackets, because this does not properly secure the access point.

Figure 2-10 Clamp Bracket Assembly Mounted on Poles Larger than 3.5 inch (8.9 cm)

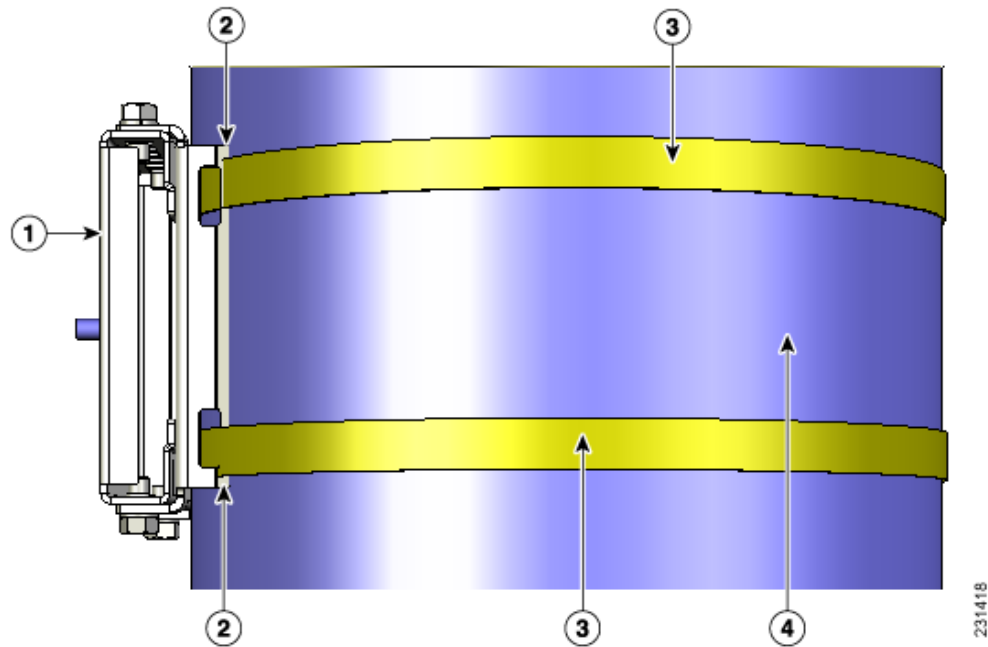

| | | | |
|----------|-----------------------------|----------|----------------------|
| 1 | Pole clamp bracket | 3 | Metal mounting strap |
| 2 | Strap slot in strap bracket | 4 | Pole |

Step 3 For pole diameters of 3.5 inch (8.9 cm) or less, mount the pole clamp bracket assembly to a pole using two metal straps looped through the space between the pole clamp bracket and the strap brackets (see [Figure 2-11](#)) to provide maximum holding strength for extreme environments. Following the instructions provided with the banding strap tool (BAND IT) (AIR-BAND-INST-TL=), loop each metal strap twice.

Figure 2-11 Metal Strap Open Space for 3.5 inch (8.9 cm) and Smaller Poles

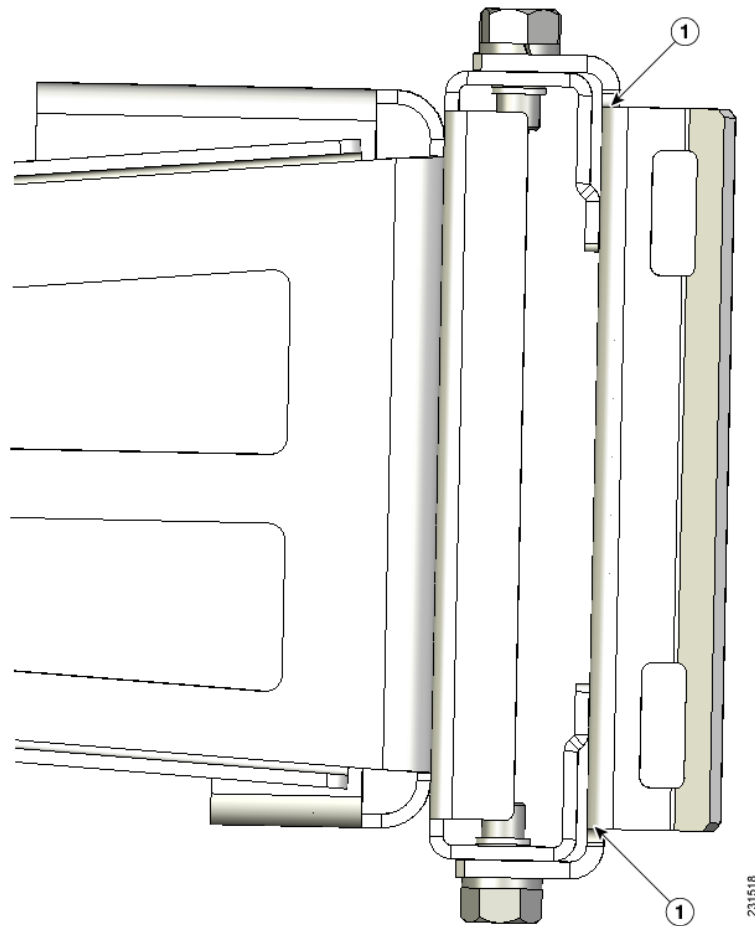

| | |
|----------|------------------------|
| 1 | Metal strap open space |
|----------|------------------------|



Caution

Do not place the metal straps in the large open area between the pole clamp bracket and the strap brackets because this does not properly secure the access point.

Step 4

Position the pole clamp bracket on the pole as needed before tightening the metal bands.



Note

When the metal bands are tightened to the full tension, the pole clamp bracket cannot be adjusted unless the metal bands are cut or disassembled.

Step 5

Tighten the metal bands using the banding strap tool (BAND IT) (Cisco AIR-BAND-INST-TL=) by following the operating instructions in the box with the tool. Ensure that the metal bands are as tight as possible.

Step 6

Place the mounting bracket onto the pole clamp bracket support bolt (see [Figure 2-12](#)).

Step 7

For vertical poles, position the mounting bracket as shown in [Figure 2-12](#). For horizontal streetlight poles, rotate the mounting bracket 90° from the position shown in [Figure 2-12](#).

Step 8 Install four M8 x16 bolts (with flat and lock washers) into the bolt holes.

Figure 2-12 Screw Hole Locations on the Mounting Bracket and Pole Clamp Bracket Assembly

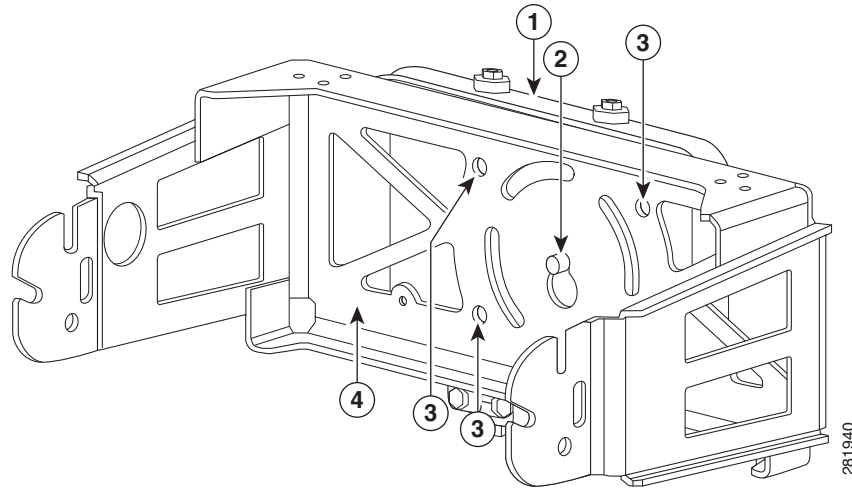

| | | | |
|----------|--|----------|------------------|
| 1 | Pole clamp bracket assembly | 3 | Bolt holes |
| 2 | Access point support bolt (M8 flange nut not shown) | 4 | Mounting bracket |

Step 9 Hand-tighten the bolts and the nut (do not overtighten).

Step 10 Adjust the top edge of the mounting bracket until it is horizontal and tighten the bolts and the flange nut (see [Figure 2-12](#)) to 13 to 15 ft lbs (17.6 to 20.3 Nm).



Note The mounting bracket can be adjusted up to 45° to compensate for tilted horizontal streetlight poles.

Step 11 Screw a M8 x16 bolt (without a flat or lock washer) in the top support bolt hole on each side the access point (see [Figure 2-13](#)). Do not screw the bolt all the way in. Leave a gap of approximately 0.25 inch (0.635 cm).

Figure 2-13 Location of Access Point Top Support Bolt Holes

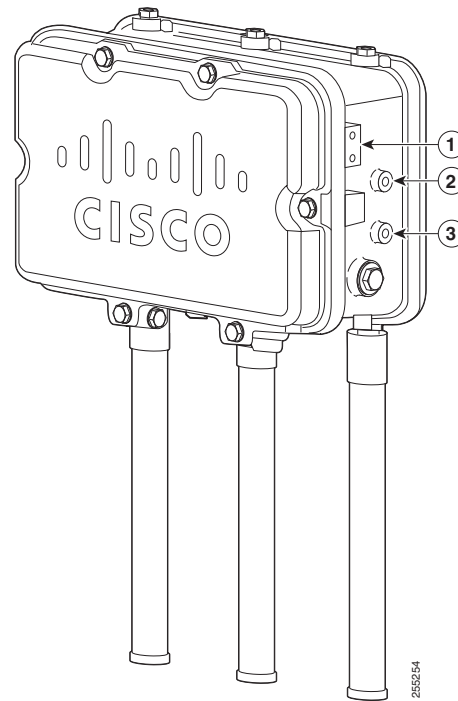

| | | | |
|----------|---|----------|----------------------------------|
| 1 | Ground lug screw holes location | 3 | Second M8 x16 bolt hole location |
| 2 | M8 x16 bolt hole (bolts are supplied with pole mount kit; install without flat or lock washers) | | |

Step 12 Position the two bolts on the access point into the access point quick-mount notch on the mounting bracket (see [Figure 2-14](#)).



Note The access point should be positioned with the LEDs on the bottom to allow viewing from the ground and with the hinged cover facing out.

Figure 2-14 Access Point Hanging in Mounting Bracket

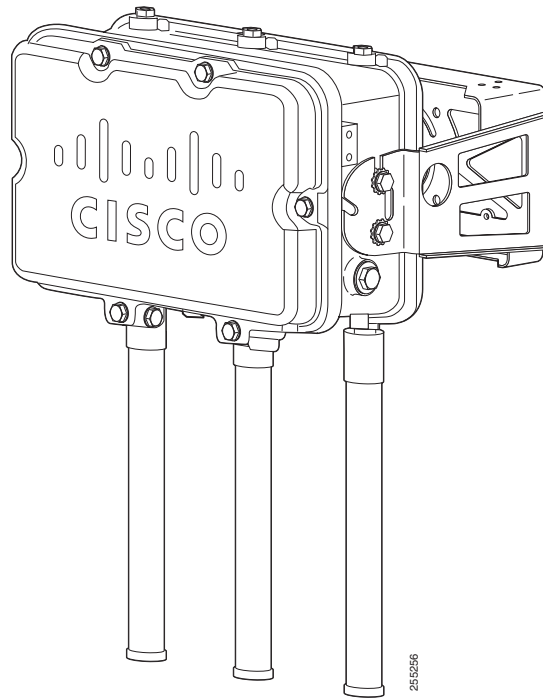

- Step 13** Screw a M8 x16 bolt (with flat and lock washers) into the second bolt hole on each side of the access point (see [Figure 2-14](#)).
- Step 14** Ensure that the front of the access point is vertical, and tighten the four bolts to 13 to 15 ft lbs (17.6 to 20.3 Nm).
- Step 15** When using the Cisco Aironet Dual-Band Omnidirectional Antennas, connect them to the access point as shown in [Figure 2-14](#). Hand-tighten the antennas to the access point.
- Step 16** Continue with the “[Grounding the Access Point](#)” section on page 2-34 and the “[Powering the Access Point](#)” section on page 2-38.
-

Cable Strand Mounting

When mounting the access point on a cable strand, you must use the optional strand mount kit. The kit contains several parts that you should assemble before mounting on a cable strand. To install the access point to a cable strand, you need to perform these operations:

- Assemble cable brackets; attach cable clamps to the clamp bracket.
- Attach the strand brackets to the access point.
- Attach the clamp bracket to the fiber or cable strand.
- Attach the Dual-Band Omnidirectional Antennas to 1552H or 1552I access points.



Note The Low Profile Dual-Band 2.4/5 GHz Omni Antenna Array should already be attached to the 1552C or 1552E access points.

- Attach a ground wire.
- Connect cables and power to the access point.



Note The access point must be installed on a cable strand by a professional cable installer.

To mount the access point, follow these steps:

- Step 1** Assemble the cable clamps to the clamp bracket on both cable brackets (Figure 2-15). You should only hand-tighten the nuts sufficiently to prevent them from falling off.

Figure 2-15 Assemble Cable Brackets

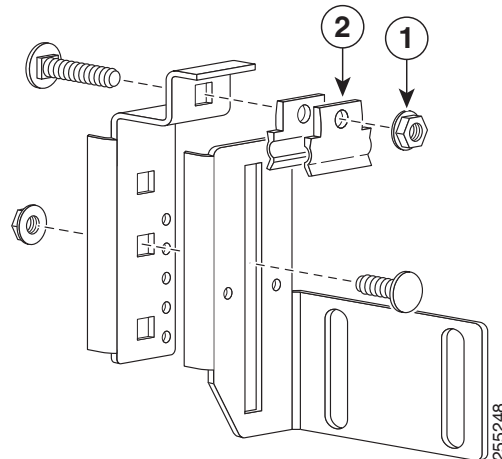

| | | | |
|----------|-------------------------------|----------|--------------|
| 1 | M8 flange nut and flat washer | 2 | Cable Clamps |
|----------|-------------------------------|----------|--------------|

- Step 2** Secure each strap bracket with two M8 x16 bolts (with lock washers) on each side of the access point with the antennas facing down. (Figure 2-16). Only hand-tighten the bolts to 13 to 15 ft lbs (17.6 to 20.3 Nm).

Figure 2-16 Attach Strap Brackets to Access Point

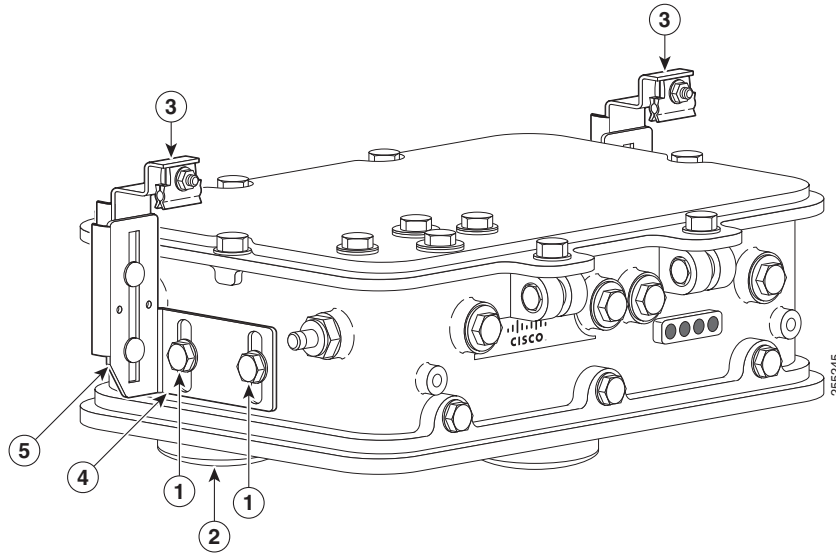

| | | | |
|---|---|---|-----------------------------|
| 1 | M8 x16 bolts with lock washers (supplied with cable mount kit) | 4 | Height and Pivot Adjustment |
| 2 | Antenna unit assembly (shown with the Low Profile Dual-Band 2.4/5 GHz Omni Antenna Array) | 5 | Height and Tilt Adjustment |
| 3 | Strap bracket assemblies | | |

Step 3 Place the clamp bracket on the strand support cable (see [Figure 2-17](#)). On each cable support bolt, ensure that one cable clamp is placed on each side of the support cable. Tighten the two M8 flange nuts to 13 to 15 in. lbs (17.6 to 20.3 Nm). Ensure the cable is mounted to the bottom side of the access point.

Figure 2-17 Attach the Cable Strand to the Cable Mount Brackets

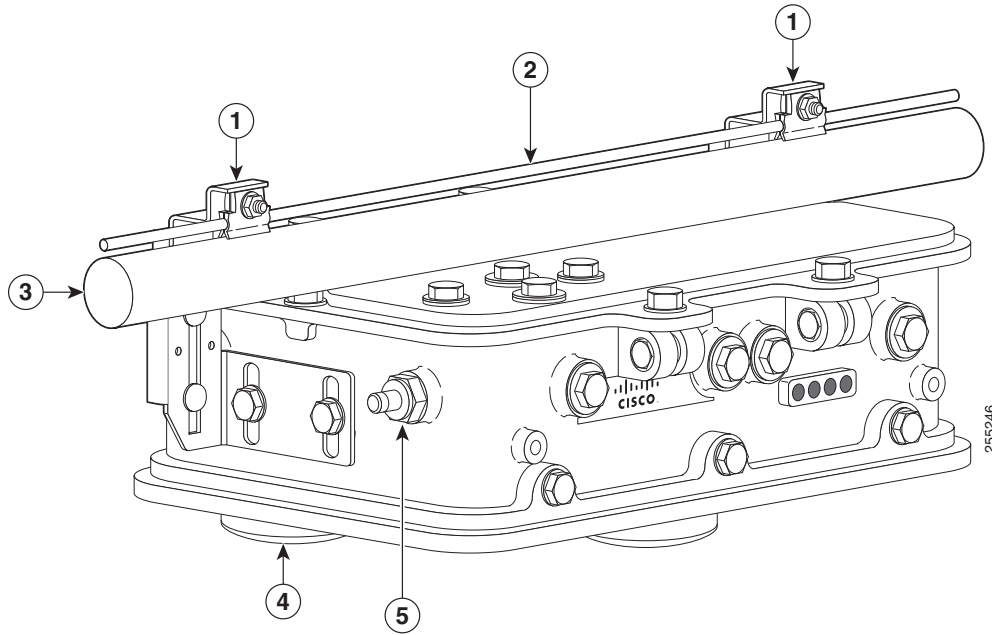

| | | | |
|---|--------------------------|---|---|
| 1 | Strap bracket assemblies | 4 | Antenna unit assembly (shown with the Low Profile Dual-Band 2.4/5 GHz Omni Antenna Array) |
| 2 | Strand support cable | 5 | F-Connector Adapter (for Cable Modem models only); sometimes referred to as a “stringer” |
| 3 | Fiber or Cable bundle | | |

Step 4 The assembled cable mounting kit is shown from the top view of the access point (Figure 2-18).

Figure 2-18 Clamp Brackets Attached to Cable Strand-Top View of Access Point

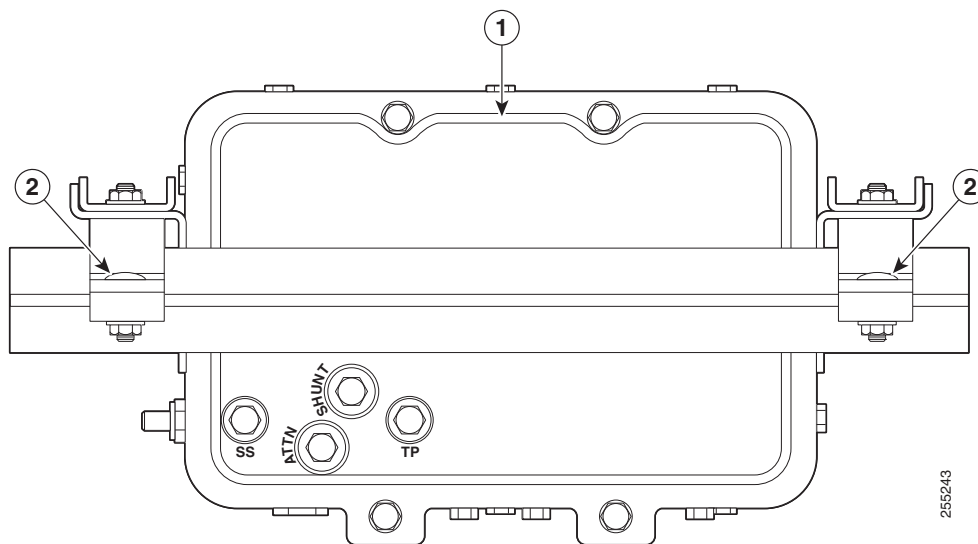

| | | | |
|---|--------------------------|---|----------------------|
| 1 | Top view of access point | 2 | Cable strand bracket |
|---|--------------------------|---|----------------------|



Note The strand support cable might have to be pulled away from the fiber or cable bundle. Be sure to resecure the cable as necessary.



Note The strand support cable and the mounting hardware provide grounding for the access point.

Step 5 Continue with the [“Grounding the Access Point”](#) section on page 2-34 and the [“Powering the Access Point”](#) section on page 2-38.

Opening the Access Point Hinged Cover

You need to open the access point hinged cover when you are performing these operations:

- Installing fiber-optic SFP module and fiber cable take-up reels
- Installing hazardous location (Haz Loc) Batter Backup Unit (BBU)

To open the access point hinged cover, follow these steps:

Step 1 Use 0.5-in (13-mm) box-end wrench or socket set to unscrew and remove the four bolts on the front cover of the unit. Only unscrew the hinge bolts about 2 turns until they are easily turned by hand, do not remove the bolts on the hinge (Figure 2-19).

Step 2 The cover is hinged on the bottom. Carefully open the cover and remove the cover.



Note If the cover does not open easily, carefully loosen the hinge bolts again.

Figure 2-19 Access Point Front View of Hinged Cover

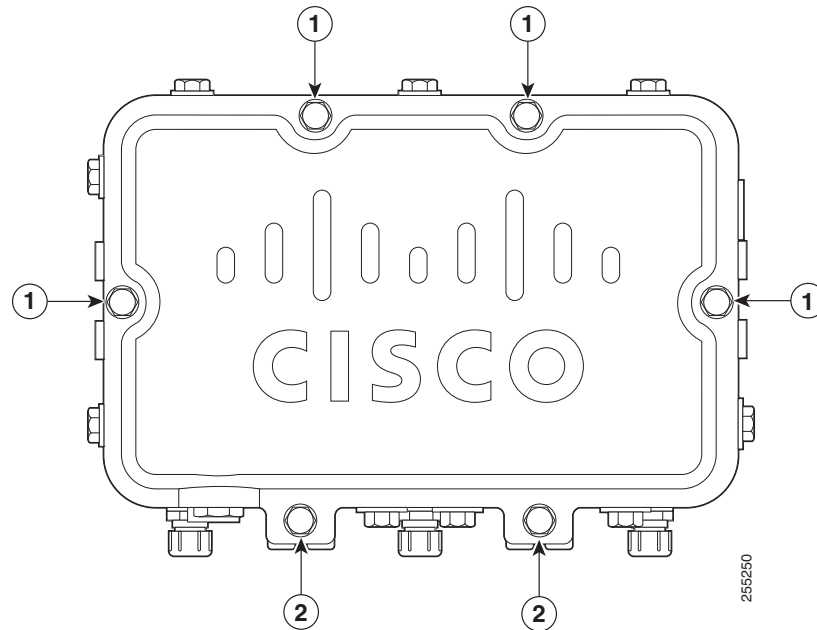

| | | | |
|----------|--------------|----------|--------------------------|
| 1 | M8 x32 bolts | 2 | Cover hinge M8 x32 bolts |
|----------|--------------|----------|--------------------------|

Closing the Access Point Hinged Cover

To close the access point cover, follow these steps:

- Step 1** When closing the access point cover, be careful not to pinch internal wires.
- Step 2** Carefully position the cover flush with all sides of the access point, then slowly hand-tighten each bolt.
- Step 3** When all bolts are hand-tightened, use a 13-mm closed-end wrench or socket to partially tighten the bolts in the tightening sequence shown in [Figure 2-20](#). Tighten each bolt to 3 to 4 ft lbs (0.34 to 0.45 Nm).
- Step 4** Repeat [Step 3](#) using the same tightening sequence to fully tighten each bolt to 6 to 7 ft lbs (0.68 to 0.79 Nm).

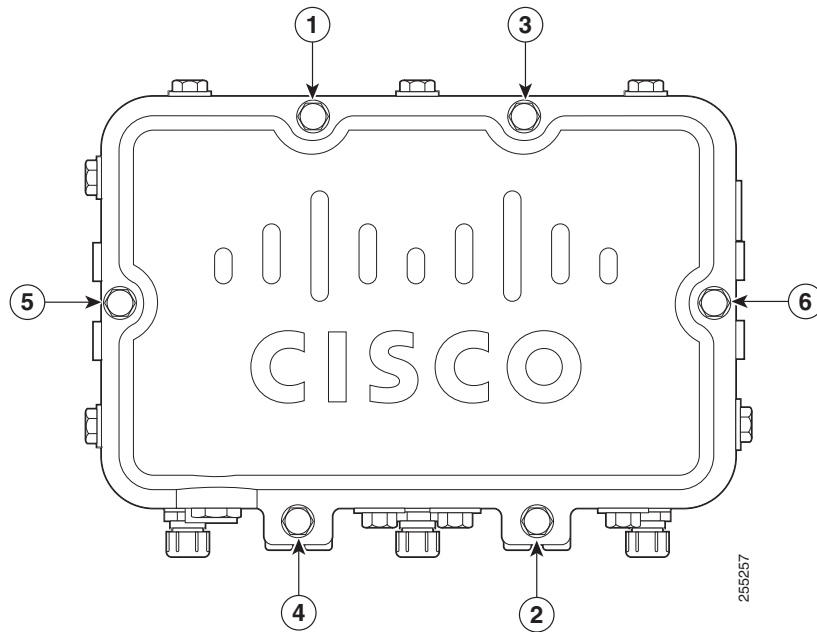
Figure 2-20 Hinged Cover Bolt Tightening Sequence

1 - 6

Tighten the bolts in the numeric order shown, starting with 1.

Using the Reset Button

The access point has a reset button located on the bottom of the unit (see [Figure 2-21](#) and [Figure 2-22](#)). The reset button is recessed in a small hole that is sealed with a screw and a rubber gasket. The reset button can be used to perform these functions:

- Reset the access point—Press the reset button for less than 10 seconds.
- Disable battery backup power—Press the reset button for more than 10 seconds.

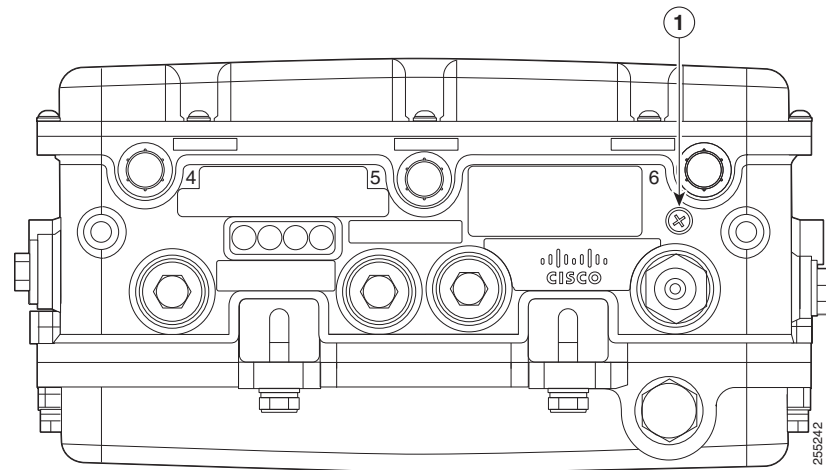
Figure 2-21 Reset Button Location - Models AIR-CAP1552E-x-K9 and AIR-CAP1552H-x-K

| | |
|---|--------------|
| 1 | Reset button |
|---|--------------|

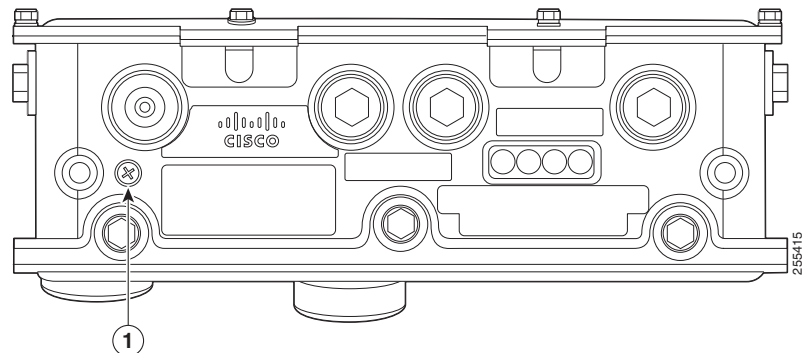
Figure 2-22 Reset Button Location - Models AIR-CAP1552C-x-K9 and AIR-CAP1552I-x-K

| | |
|---|--------------|
| 1 | Reset button |
|---|--------------|

Reboot the Access Point

To reboot (power cycle) the access point, follow these steps:

-
- Step 1** Use a Phillips screwdriver to remove the reset button screw (Figure 2-21). Be careful not to lose the screw.
 - Step 2** Use a straightened paperclip, and push the reset button for less than 10 seconds. This action causes the access point to reboot (power cycle), all LEDs to turn off for approximately 5 seconds, and then the LEDs to reactivate.
 - Step 3** Replace the reset button screw and use a Phillips screwdriver to tighten to 22 to 24 in. lbs (2.49 to 2.71 Nm).
-

Disabling Backup Battery Power

To disable battery backup power, follow these steps:

-
- Step 1** Use a Phillips screwdriver to remove the reset button screw (Figure 2-21). Be careful not to lose the screw.
- Step 2** Use a straightened paper clip and push the reset button for longer than 10 seconds.
- When the access point is only battery powered, the access point reboots and then disables the backup battery power. The LEDs turn off for approximately 5 seconds, reactivate for approximately 5 seconds, and then turn off and stay off.
 - When the access point has battery power and another power source, the access point reboots, then disables the battery and continues operating from the second power source. The LEDs turn off for approximately 5 seconds and then reactivate.



Note If your access point does not contain a battery backup unit, the access point only reboots.



Note The battery backup unit is reactivated when the access point is rebooted (power cycled) again.

- Step 3** Replace the reset button screw, and use a Phillips screwdriver to tighten to 22 to 24 in. lbs (2.49 to 2.71 Nm).
-

Grounding the Access Point

The access point must be grounded before connecting power.



Warning

This equipment must be externally grounded using a customer-supplied ground wire before power is applied. Contact the appropriate electrical inspection authority or an electrician if you are uncertain that suitable grounding is available. Statement 366



Warning

Installation of the equipment must comply with local and national electrical codes. Statement 1074



Note

When the access point is cable strand mounted, the strand support cable and the mounting hardware provide grounding for the access point.

In all outdoor installations and when powering the access point with AC power, you must follow these instructions to properly ground the case:

-
- Step 1** If using insulated 6-AWG copper ground wire, strip the insulation as required for the grounding lug.
-

- Step 2** Use the appropriate crimping tool to crimp the bare 6-AWG copper ground wire to the supplied grounding lug (Panduit PLCD6-10A-L).



Note The grounding lug and hardware used must comply with local and national electrical codes.

- Step 3** Open the electrical joint compound (supplied), and apply a liberal amount over the metal surface where the ground strap screw holes are located (see [Figure 2-13](#)).
- Step 4** Connect the grounding lug to the access point grounding screw holes (see [Figure 2-13](#)) using the supplied two Phillips head screws (M4 x10 mm) with lock washers. Tighten the grounding screw to 22 to 24 in. lbs (2.49 to 2.71 Nm).
- Step 5** If necessary, strip the other end of the ground wire, and connect it to a reliable earth ground such as a grounding rod (see [Figure 2-2](#)), an appropriate grounding point on a metal streetlight pole that is grounded (see [Figure 2-29](#)), or a grounded cable on a cable strand.

Connecting a Fiber-Optic Cable to the Access Point

The fiber-optic kit (GLC-FE-100BX-URGD=) enables the 1552E and 1552H access points to support fiber-optic network connections. The kit contains these parts:

- 100BASE-BX10-U rugged SFP module
 - Single strand fiber bidirectional optical transceiver
 - 1.3/1.5 micro-meter wavelength division multiplexing (WDM) function
 - 125-Mb/s data rates
 - Single mode LC receptacle
- Eight screws
- Two small take-up reels
- Two large take-up reels
- One liquid-tight adapter—Accepts a cable diameter of 0.20 to 0.35 inches (0.51 to 0.89 cm)



Note Fiber backhaul is only possible on the 1552E and 1552H access points.



Warning **Class 1 laser product.** Statement 1008



Note You need a customer-supplied outdoor-rated fiber-optic cable with an LC connector. The cable diameter must be 0.20 to 0.35 in. (0.52 to 0.89 cm) in diameter.

To connect a fiber-optic cable to the access point, follow these steps:

- Step 1** Ensure that all power sources have been disconnected from the access point.

**Warning**

This unit might have more than one power supply connection. All connections must be removed to de-energize the unit. Statement 1028



Note If your access point contains a backup battery pack, you must depress the reset button for 10 seconds or more (see the “Disabling Backup Battery Power” section on page 2-34).

- Step 2** Open the hinged cover (see the “Opening the Access Point Hinged Cover” section on page 2-30 for instructions).
- Step 3** Place the two large reels with the small reels on top as shown in Figure 2-23.
- Step 4** Align the screw holes in the large and small reels, and insert four attachment screws in each of the reel pairs. Tighten the screws to 3 to 4 in. lbs (0.34 to 0.45 Nm).
- Step 5** Remove the plug from the end of the SFP module, and insert the module into the SFP receptacle (see Figure 2-23).

Figure 2-23 Fiber-Optic Cable Components

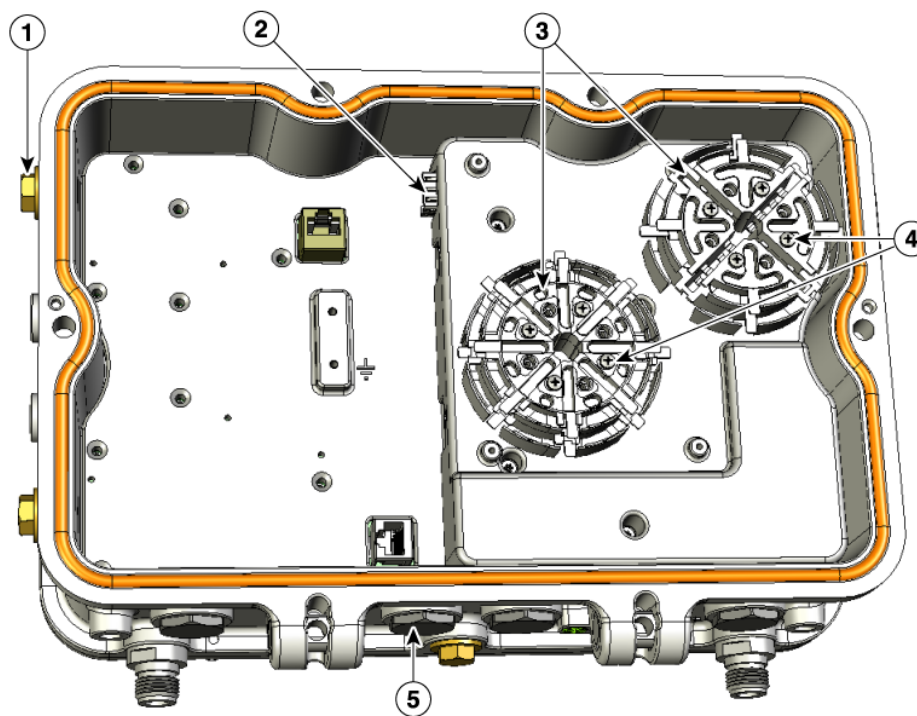

231591

| | | | |
|---|---|---|------------------------------------|
| 1 | Not used | 4 | Four screws for each reel assembly |
| 2 | SFP module slot | 5 | Fiber-optic connector plug |
| 3 | Fiber reels (large reel with small reel on top) | | |

- Step 6** Loosen the round end of the liquid-tight connector by turning counterclockwise, but do not remove (see [Figure 2-24](#)).

Figure 2-24 *Liquid-Tight Adapter*



| | | | |
|----------|------------|----------|-----------|
| 1 | Thread end | 2 | Round end |
|----------|------------|----------|-----------|

- Step 7** Carefully screw the threaded end of the adapter into the access point and hand-tighten.
- Step 8** Use an adjustable wrench, the 22 mm socket, or the Sealcon S-2200-WR wrench to tighten the threaded end of the adapter to 6 to 7 ft lbs (8.1 to 9.5 Nm).
- Step 9** Carefully remove approximately 1 to 2 ft (30.5 cm) of the external jacket from the fiber-optic cable, exposing the inner strand.
- Step 10** Carefully insert the fiber-optic LC cable connector into the rounded end of the liquid-tight adapter (see [Figure 2-24](#)), and push through the adapter.
- Step 11** Wrap excess fiber-optic cable around the take-up reels in a figure eight (8) pattern.
- Step 12** Insert the fiber-optic LC cable connector into the SFP module.
- Step 13** Use an adjustable or open-end wrench to tighten the round end of the adapter to 2.7 to 3.2 ft lbs (3.66 to 4.34 Nm).
- Step 14** Close the hinged cover (see the [“Closing the Access Point Hinged Cover”](#) section on page 2-31).

Powering the Access Point

The access point can be powered by one of these methods:

- PoE—56 VDC; for 1552E/1552H access points
 - [Connecting a 1500 Series Power Injector, page 2-38](#)
- AC power
 - 110 to 240 VAC for a 1552I access point—[Connecting Streetlight AC Power, page 2-44](#)
 - 110 to 480 VAC for 1552E/1552H access points—[Connecting Streetlight AC Power, page 2-44](#)
 - 120 VAC—[Connecting an AC Power Cable to the Access Point, page 2-47](#)
- External 12 VDC
 - [Connecting a DC Power Cable to the Access Point, page 2-48](#)
- POC—40 to 90 VAC (Quasi-AC); only for a 1552C access point
 - [Connecting a Cable POC Power to the Access Point, page 2-51](#)



Note

In all cases above, the AC branch circuit powering the access point must be limited to no more than 20A from the over-protection device supplied by the user. This branch power protection must meet all local and national electrical codes.

Connecting a 1500 Series Power Injector

The power injector provides 56 VDC to the access point over the Ethernet cable and supports a total end-to-end Ethernet cable length of 100 m (328 ft) from the switch to the access point.



Note

The cable from the power injector to the access point (PoE-in port) must be at least 10 ft (3.05 m) long.



Note

The PoE-Out port is disabled when the access point is powered by the power injector.

When your access point is powered by an optional power injector, follow these steps to complete the installation:

- Step 1** Before applying PoE to the access point, ensure that the access point is grounded (see the [“Grounding the Access Point”](#) section on page 2-34).
- Step 2** Review [Figure 2-2](#) to identify the components needed for the installation.



Note

The 1550 power injector can only be used in an indoor environment, therefore, the cable from the injector must travel from the protected location to the outside mounted access point.

- Step 3** Connect a CAT5e or better Ethernet cable from your wired LAN network to the power injector.



Warning

To reduce the risk of fire, use only No. 26 AWG or larger telecommunication line cord. Statement 1023

Use only the 1500 power injector (AIR-PWRINJ1500-2=) for the access point. This power injector is designed to meet the power requirements of the access point and is a listed Class 2 limited power source (LPS).

**Note**

The installer is responsible for ensuring that powering the access point from this type of power injector is allowed by local and/or national safety and telecommunications equipment standards.

**Tip**

To forward bridge traffic, add a switch between the power injector and controller. Refer to the *Cisco Wireless Mesh Access Points, Design and Deployment Guide, Release 7.0* for more information.

- Step 4** Ensure that the antennas are connected and that a ground is attached to the access point before you apply power to the access point.
- Step 5** Connect a shielded outdoor-rated Ethernet (CAT5e or better) cable between the power injector and the PoE-in connector of the access point (see [Figure 2-25](#)).
- Step 6** Connect the Ethernet cable to the access point PoE-In port (see [“Connecting an Ethernet Cable to the Access Point”](#) section on page 2-39).

**Note**

When a 1552E or 1552H access point is powered by PoE, the PoE-Out port is not active.

- Step 7** Continue with the [“What to Do Next”](#) section on page 2-63.

Connecting an Ethernet Cable to the Access Point

You need to supply these tools and materials:

- Shielded outdoor-rated Ethernet (CAT5e or better) cable with 0.2 to 0.35 in. (0.51 to 0.89 cm) diameter

**Note**

The Ethernet cable from the power injector to the access point must be at least 10 ft (3.05 m) long. The PoE-out port is disabled when the access point is powered by the power injector.

- RJ-45 connector and installation tool
- Adjustable wrench

To connect the shielded Ethernet cable to the access point, follow these steps:

Step 1

Disconnect power to the power injector, and ensure all power sources to the access point are turned off.

**Warning**

This unit might have more than one power supply connection. All connections must be removed to de-energize the unit. Statement 1028



Note If your access point contains a backup battery pack, you must press the reset button for 10 seconds or more (see the [“Disabling Backup Battery Power”](#) section on page 2-34).

- Step 2** Ensure a 6 AWG ground wire is connected to the access point (see the [“Grounding the Access Point”](#) section on page 2-34).
- Step 3** Use an adjustable wrench, a 22-mm socket, or the Sealcon S-2200-WR wrench to remove the Ethernet connector plug from the access point (see [Figure 2-25](#) for the location).

Figure 2-25 Location of Ethernet Liquid-Tight Adapters (Only Models AIR-CAP1552E-x-K9 and AIR-CAP1552H-x-K9)

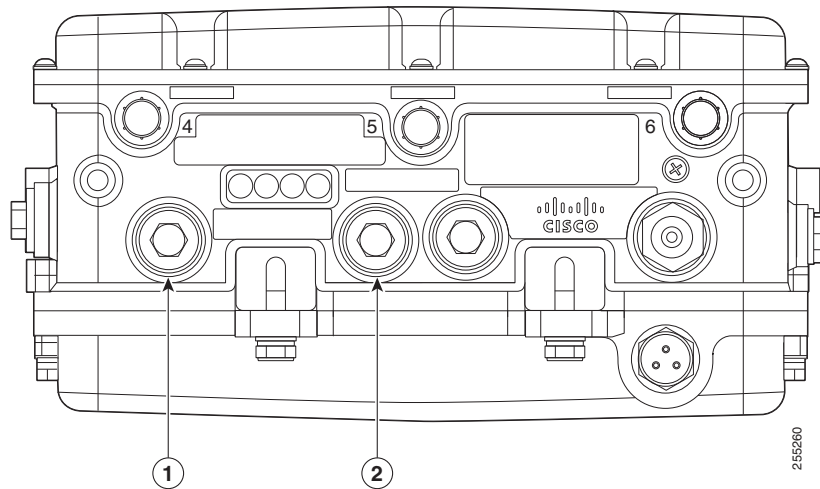

| | | | |
|----------|-------------|----------|--------------|
| 1 | PoE-in port | 2 | PoE-out port |
|----------|-------------|----------|--------------|



Note For information on data cable entry, refer to [Figure 1-1](#) on page 1-7

- Step 4** Loosen the round end of the liquid-tight adapter by turning counterclockwise, but do not remove (see [Figure 2-26](#)).

Figure 2-26 liquid-tight Adapter



| | | | |
|----------|------------|----------|-----------|
| 1 | Thread end | 2 | Round end |
|----------|------------|----------|-----------|

- Step 5** Insert the unterminated end of the Ethernet cable into the round end of the liquid-tight adapter (see [Figure 2-26](#)), and pull several inches of cable through the adapter.
- Step 6** Install an RJ-45 connector on the unterminated end of the Ethernet cable using your Ethernet cable installation tool.

Warning

To reduce the risk of fire, use only No. 26 AWG or larger telecommunication line cord. Statement 1023

- Step 7** Carefully insert the RJ-45 cable connector into the Ethernet port opening on the access point, and connect to the internal Ethernet connector (see [Figure 2-27](#)).

Figure 2-27 Inserting RJ-45 Connector into the Ethernet Port Opening in Case

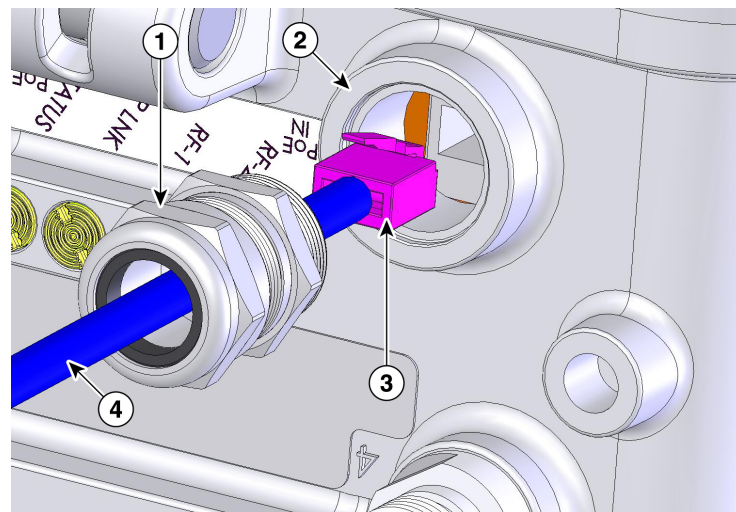

| | | | |
|----------|--|----------|---|
| 1 | Liquid-tight adapter | 3 | RJ-45 connector |
| 2 | Ethernet port opening in access point case | 4 | Shielded outdoor-rated Ethernet (CAT5e or better) cable |

- Step 8** Slide the liquid-tight adapter towards the access point, and screw the threaded end of the adapter into the access point, and hand-tighten.
- Step 9** Use an adjustable wrench, a 22-mm socket, or a Sealcon S-2200-WR wrench to tighten the threaded end of the adapter to 6 to 7 ft lbs (8.1 to 9.5 Nm).
- Step 10** Use an adjustable wrench and tighten the round end of the adapter to 2.7 to 3.2 ft lbs (3.66 to 4.34 Nm).
- Step 11** Ensure that the antennas are connected to the access point before you apply power to the access point.
- Step 12** Route your Ethernet cable, and cut off any excess cable.
- Step 13** Install an RJ-45 connector on the unterminated cable end, and insert it into the power injector. For typical installation components, see [Figure 2-2](#).
- Step 14** Turn on power to the power injector.
-

AC Power Cords for Cisco Aironet 1550 Series Outdoor Mesh Access Points

The Cisco Aironet 1550 series outdoor mesh access point supports these AC power cord options:

- 40-ft (12.2-m) power cord (AIR-CORD-R3P-40NA=) for light pole installations in the US and Canada.
- 40-ft (12.2-m) power cord (AIR-CORD-R3P-40UE=) for light pole installations in the European Union.
- 4-ft (1.2-m) streetlight power tap adapter (AIR-PWR-ST-LT-R3P=) for light pole installations in the US and Canada.



Warning

A readily accessible two-poled disconnect device must be incorporated in the fixed wiring. Statement 1022



Caution

Prior to connecting or disconnecting a power cord, you must remove AC power from the power cord using a suitable service disconnect.



Note

European Union users need to install a country-specific plug to the blunt cut end of the cable assembly.



Note

In all installations, the detachable power cord (pluggable Type B) must be an approved type acceptable to the authorities in the country where the unit is sold, and must meet all local and national electrical codes.

Table 2-3 AC Power Cord Information

| AC Power Cord | Cord Diameter | Comment |
|--------------------|--|--|
| AIR-CORD-R3P-40NA= | 0.398 to 0.413 in. (10.1 mm to 10.5 mm) | The three prong plug is limited to 120 VAC. Internal wiring is rated at 600 VAC insulation protection. |
| AIR-CORD-R3P-40UE= | 0.398 to 0.413 in.(10.1 mm to 10.5 mm) | Power cord rating is 100 to 480 VAC. |
| AIR-PWR-ST-LT-TAP= | Strain relief bushing not needed | Power cord rating is 100 to 480 VAC |

When using a user-supplied AC power plug on the AIR-CORD-R3P-40UE= power cord, ensure that the plug is certified for outdoor use and that it has a minimum IP67 rating, such as Interpower 84131251 or Hubbell HBL316P6W (IEC/EN 60309) pin-and-sleeve type connectors. The European Union power cord plug pinouts are listed in [Figure 2-28](#). For the location of the AC power connectors, see [Figure 2-30](#) and [Figure 2-31](#).

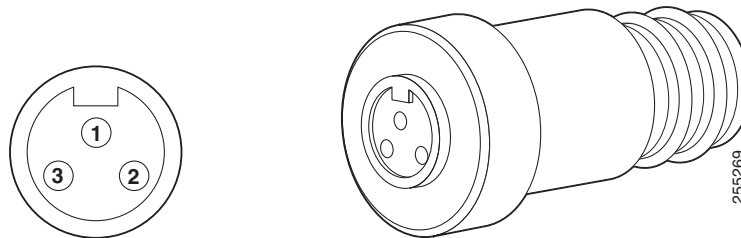
Figure 2-28 European Union Plug Pinouts

| Pin | Description | Conductor Color | Pin | Description | Conductor Color |
|-----|-------------|-----------------|-----|-------------|-----------------|
| 1 | Ground | Green/Yellow | 3 | Neutral | Blue |
| 2 | Live | Brown | | | |

**Caution**

All AC power plugs and AC receptacles must be protected from water and other outdoor elements. Use a UL listed waterproofing enclosure suitable for covering the AC receptacle and AC power plug that supplies power to the unit as described in Article 406 of the NEC. If the power cord goes through a metal cover, install a bushing to prevent fraying of the cord.

When using a strain relief bushing, you should follow these recommendations:

- Use properly sized parts (see [Table 2-3](#) for the power cord diameter)
- Use bushings that are safety certified
- Use parts that are suitable for outdoor installation

**Caution**

If your power cord does not use an AC power plug, you must ensure that the power source is OFF before connecting or disconnecting the power cord wires from the power source.

**Warning**

When installing or replacing the unit, the ground connection must always be made first and disconnected last. Statement 1046

Connecting Streetlight AC Power

The access point can be installed on a streetlight pole and powered from a streetlight outdoor light control using the optional streetlight power tap adapter.

**Caution**

The access point can be powered by a light pole twist-lock outdoor light control that provides 100-to 480-VAC 50/60 Hz power. Do not connect to an outdoor light control powered by higher voltages.

When powering the access point with AC power other than the streetlight power tap adapter, you must ensure that the following conditions are observed:

1. AC power can be conveniently removed from the unit. The power should not be removed by disconnecting the AC power connector on the unit.

**Warning**

A readily accessible two-poled disconnect device must be incorporated in the fixed wiring. Statement 1022

**Caution**

Before connecting or disconnecting a power cord, you must remove AC power from the power cord using a suitable service disconnect.

2. You must protect any AC power plugs and AC receptacles from water and other outdoor elements. You can use a UL-listed waterproofing enclosure suitable for covering the AC receptacle and AC power plug that supplies power to the unit as described in Article 406 of the NEC.
3. When you install the access point outdoors or in a wet or damp location, the AC branch circuit that powers the access point should have ground fault protection (GFCI), as required by Article 210 of the National Electrical Code (NEC).

**Warning**

Be very careful when connecting the streetlight adapter to Category 3 pole-top power. If you are not careful, you may electrocute yourself or fall. Statement 363

For additional important safety instructions for AC power cords, refer to the *AC Power Cords for Cisco Aironet 1550 Series Outdoor Mesh Access Points* document that shipped with your AC power cords.

To install an access point on a streetlight pole, follow these steps:

- Step 1** Before beginning the installation, ensure the AC power to the streetlight pole is turned off.
- Step 2** Turn off power to the AC power source at the designated circuits.

**Warning**

This unit might have more than one power supply connection. All connections must be removed to de-energize the unit. Statement 1028

**Caution**

For your safety, when connecting the access point AC power connector, always connect the access point end of the cable FIRST. When removing the AC power connector, always disconnect the access point end of the cable LAST.

If your access point contains a backup battery pack, you must press the reset button for 10 seconds or more (see the “Disabling Backup Battery Power” section on page 2-34.)

- Step 3** When using the streetlight power tap adapter (AIR-PWR-ST-LT-R3P=), ensure that the access point is mounted within 3 feet (1 m) of the outdoor light control. For mounting instructions, refer to the “Mounting the Access Point on a Pole” section on page 2-19.
- Step 4** Ensure that a 6-AWG ground wire is attached to the access point (see Figure 2-29) and connected to the streetlight pole (for instructions see [Grounding the Access Point](#), page 2-34).

Figure 2-29 Using the Streetlight Power Tap Adapter

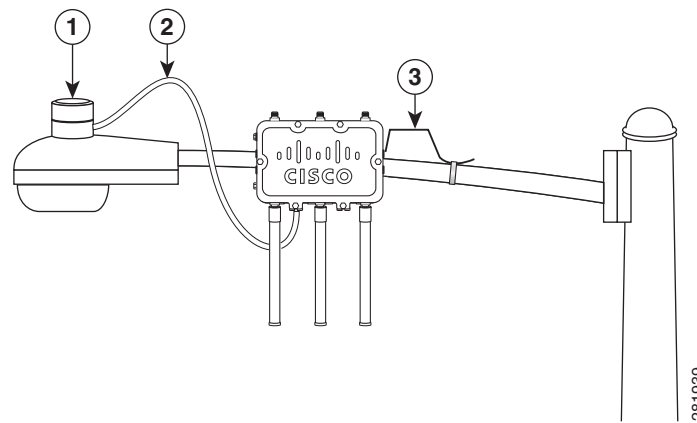

| | | | |
|----------|-------------------------------|----------|-----------------------------|
| 1 | Outdoor light control | 3 | 6-AWG copper grounding wire |
| 2 | Streetlight power tap adapter | | |

- Step 5** Ensure that the streetlight power tap adapter, which uses a 3-pronged LC-10 twist-lock adapter, is placed between the outdoor light control and its fixture (refer to Figure 2-29). The LC-10 twist-lock adapter is designed to be used with LC-10 listed outdoor light controls operating at 100 to 480 VAC, 50 to 60 Hz.
- Step 6** Disconnect the outdoor light control from its fixture.
- Step 7** Verify that the voltage available at the fixture is between 100 and 480 VAC, 50 to 60 Hz.
- Step 8** Turn off power to the fixture at the designated circuits.

**Caution**

When installing the streetlight power tap adapter to the access point AC power connector, always connect the access point end of the cable FIRST. When removing the streetlight power tap adapter, always disconnect the access point end of the cable LAST.

**Note**

Ensure that your antennas are connected to the access point before you apply power to the access point.

- Step 9** Connect the streetlight power tap adapter to the access point AC power connector, as shown in [Figure 2-30](#) and [Figure 2-31](#). Hand-tighten the connector.

Figure 2-30 AC Power Connector - Shown on Access Point Model AIR-CAP1552E-x-K9

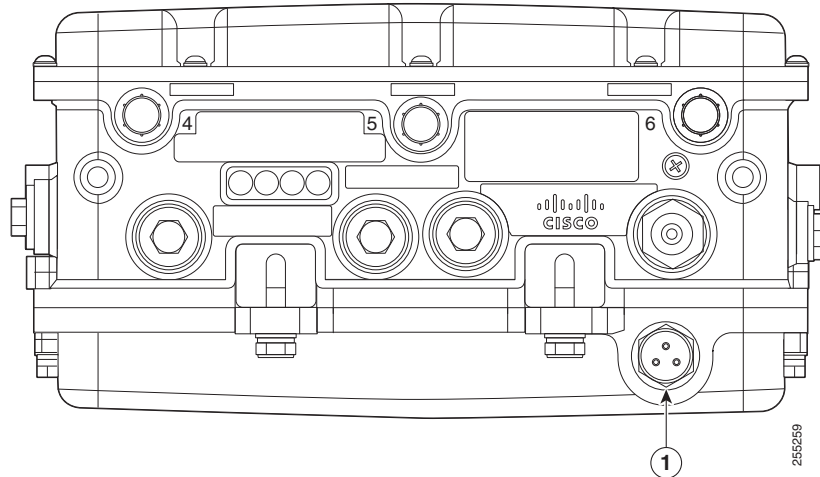

1 AC power connector

Figure 2-31 AC Power Connector - Shown on Access Point Model AIR-CAP-1552I-x-K9

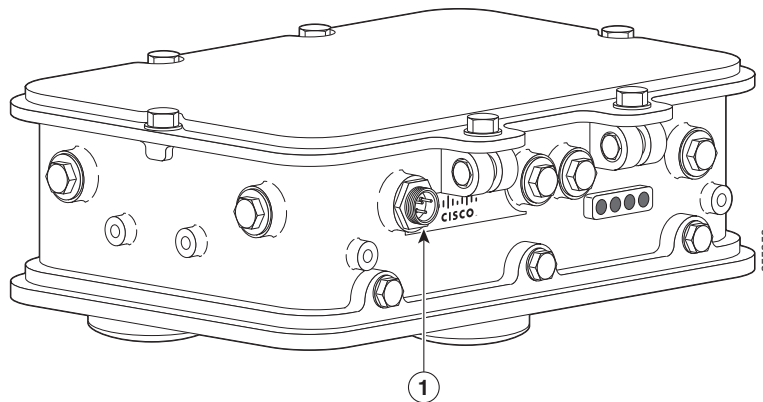

1 AC power connector

- Step 10** Plug the streetlight power tap adapter into the outdoor light control fixture, as shown in [Figure 2-29](#).
- Step 11** Plug the outdoor light control into the streetlight power tap adapter.
- Step 12** Ensure that the antennas are connected to the access point before you apply power to the access point.
- Step 13** Turn on the power to the outdoor light control fixture at the designated circuits.
-

Connecting an AC Power Cable to the Access Point

When powering the access point with AC power other than the streetlight power tap adapter, you must ensure that the following conditions are observed:

1. AC power can be conveniently removed from the unit. The power should not be removed by disconnecting the AC power connector on the unit.



A readily accessible two-poled disconnect device must be incorporated in the fixed wiring.

Statement 1022



Before connecting or disconnecting a power cord, you must remove AC power from the power cord using a suitable service disconnect.

2. You must protect any AC power plugs and AC receptacles from water and other outdoor elements. You can use a UL-listed waterproofing enclosure suitable for covering the AC receptacle and AC power plug that supplies power to the unit as described in Article 406 of the NEC.
3. When you install the access point outdoors or in a wet or damp location, the AC branch circuit that powers the access point should have ground fault protection (GFCI), as required by Article 210 of the National Electrical Code (NEC).



For additional important safety instructions for AC power cords, refer to the *AC Power Cords for Cisco Aironet 1550 Series Outdoor Mesh Access Points* document that shipped with your AC power cords.

The access point supports this Cisco AC power cable:

- 40 ft (12.2 m) AC power cable (AIR-CORD-R3P-40NA=)

To connect an AC power cable to the access point, perform these steps:

Step 1 Prior to applying AC power, ensure the access point is grounded (see [Grounding the Access Point, page 2-34](#)).

Step 2 Turn off power to the AC power source at the designated circuits.



This unit might have more than one power supply connection. All connections must be removed to de-energize the unit. Statement 1028



When connecting the access point AC power connector, always connect the access point end of the cable FIRST. When removing the AC power connector, always disconnect the access point end of the cable LAST.



If your access point contains a backup battery pack, you must press the reset button for 10 seconds or more (see the [“Disabling Backup Battery Power”](#) section on page 2-34).

- Step 3** Align the notch in the AC power cable connector with the key in the access point AC power connector, and push the cable connector into the access point connector (see [Figure 2-30](#) or [Figure 2-31](#)). When fully seated, rotate the cable connector ring clockwise until hand-tight.
- Step 4** Ensure that the antennas are connected to the access point before you apply power to the access point.
- Step 5** Turn on the AC power at the designated circuits.

Connecting a DC Power Cable to the Access Point

When powering the access point with DC power, you must ensure that DC power can be conveniently removed from the unit. The power should not be removed by disconnecting the DC power connector on the unit.



Warning

A readily accessible two-poled disconnect device must be incorporated in the fixed wiring.

Statement 1022



Warning

Connect the unit only to DC power source that complies with the safety extra-low voltage (SELV) requirements in IEC 60950 based safety standards. Statement 1033

To connect a DC power cable, you need to supply these tools and material:

- Shielded outdoor-rated DC power cable with cable diameter of 0.20 to 0.35 inch (0.51 to 0.89 cm).
- Adjustable or open-end wrench
- Small flat screw driver
- Two-pin DC power connector (Cisco supplied)

To connect the DC power cable to the access point, follow these steps:

- Step 1** Before connecting DC power to the access point, ensure that the ground is connected to the access point (see the [“Grounding the Access Point”](#) section on page 2-34).
- Step 2** Turn off all power sources to the access point, including the DC power source.



Warning

This unit might have more than one power supply connection. All connections must be removed to de-energize the unit. Statement 1028



Caution

When installing DC power to the access point, always connect the access point end of the cable FIRST. When removing the DC power connector, always disconnect the access point end of the cable LAST.

If your access point contains a backup battery pack, you must press the reset button for 10 seconds or more (see the [“Disabling Backup Battery Power”](#) section on page 2-34.)

- Step 3** Use an adjustable wrench, a 22-mm socket, or a Sealcon S-2200 -WR wrench to remove the plug in the DC power connector opening (see [Figure 2-32](#) for the location of the DC power connector).

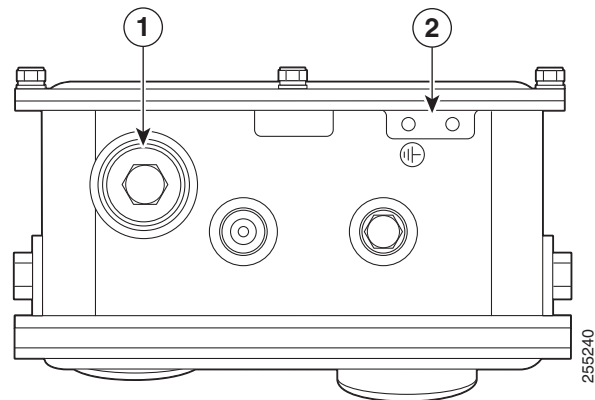
Figure 2-32 Location of the DC Power Liquid-Tight Adapter

| | | | |
|----------|--|----------|------------------------|
| 1 | DC power connector with liquid-tight adapter | 2 | Ground lug screw holes |
|----------|--|----------|------------------------|

- Step 4** Loosen the round end of the liquid-tight adapter by turning counterclockwise, but do not remove (see [Figure 2-33](#)).

Figure 2-33 Liquid-Tight Adapter

| | | | |
|----------|------------|----------|-----------|
| 1 | Thread end | 2 | Round end |
|----------|------------|----------|-----------|



Note The liquid-tight adapter accepts a cable diameter of 0.20 to 0.35 in. (0.51 to 0.89 cm).

- Step 5** Insert a bare end of the DC power cable into the rounded end of the liquid-tight adapter (see [Figure 2-33](#)), and pull approximately 6 inches of cable through the adapter.
- Step 6** Strip the DC cable jacket back about 1 inch to expose the wires and strip the insulation about 3/8 inch (9.5 mm) from each wire.
- Step 7** Insert each wire into the two-position terminal strip (supplied), and tighten each wire using a 0.1 inch (0.25 cm) flat screw driver (see [Figure 2-34](#)).

Figure 2-34 Two-Position Terminal Strip



| | | | |
|---|-------------------------------------|---|-----------------------|
| 1 | Securing screws | 3 | Wire opening for DC + |
| 2 | Wire opening for ground (DC return) | | |

Step 8 Insert the two-position terminal strip into the DC power opening in the access point case, and carefully push the terminal strip into the internal connector (see [Figure 2-35](#)).

Figure 2-35 Inserting the Terminal Strip into the DC Power Opening in the Access Point Case

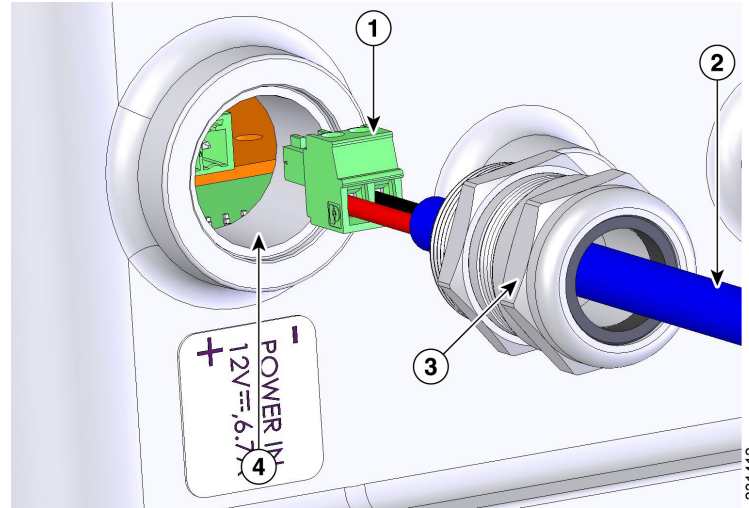

| | | | |
|---|-----------------------------|---|---------------------------------------|
| 1 | Two-position terminal strip | 3 | Liquid-tight adapter |
| 2 | DC power cable | 4 | DC power opening in access point case |
| <p> Note For specifications and restrictions on power cable connections, refer to Figure 2-43</p> | | | |

- Step 9** Slide the liquid-tight adapter towards the access point, and screw the threaded end of the adapter into the access point, and hand-tighten.
- Step 10** Use an adjustable wrench, a 22-mm socket, or a Sealcon S-2200-WR wrench to tighten the threaded end of the adapter to 6 to 7 ft lbs (8.1 to 9.5 Nm).
- Step 11** Use an adjustable or open-end wrench to tighten the round end of the adapter to 2.7 to 3.2 ft lbs (3.66 to 4.34 Nm).
- Step 12** Ensure that the antennas are connected to the access point before you apply power to the access point.
- Step 13** Turn on the DC power at the designated circuits.

Connecting a Cable POC Power to the Access Point

The cable configuration on a 1552C access point contains a cable modem and RF splitter but does not contain a cable stinger connector. The cable stinger connector is customer supplied.

 **Note**

To ensure system performance, with respect to immunity from external electromagnetic fields, the installer must use a well shielded coax cable (quad shield).

**Note**

The POC access point is classified as a type “Hazardous Voltage Secondary” circuit as per the UL/IEC/EN 60950-1 safety standard. The cable distribution network used with this access point must provide transient reduction to the level for this type of circuit classification (that is, 500V transient/lightning surge).

To connect cable POC power to the access point, follow these steps:

Step 1 Before connecting cable POC power to the access point, ensure that the ground is connected to the access point (see the “[Grounding the Access Point](#)” section on page 2-34).

Step 2 Ensure that all power sources have been disconnected from the access point.

**Warning**

This unit might have more than one power supply connection. All connections must be removed to de-energize the unit. Statement 1028

If your access point contains a backup battery pack, you must press the reset button for 10 seconds or more (see the “[Disabling Backup Battery Power](#)” section on page 2-34).

Step 3 Remove the ATTN and SHUNT connector plugs on the top of the access point. Follow your cable company procedures to measure the cable signal strength and possibly adjust signal attenuation externally to the access point or on the RF splitter (see [Figure 2-36](#)).



Note The cable modem MAC address is located on the bottom of the access point under the LEDs.

Step 4 Locate the F-connector adapter on the access point (see [Figure 2-36](#)).

Figure 2-36 RF Splitter Components

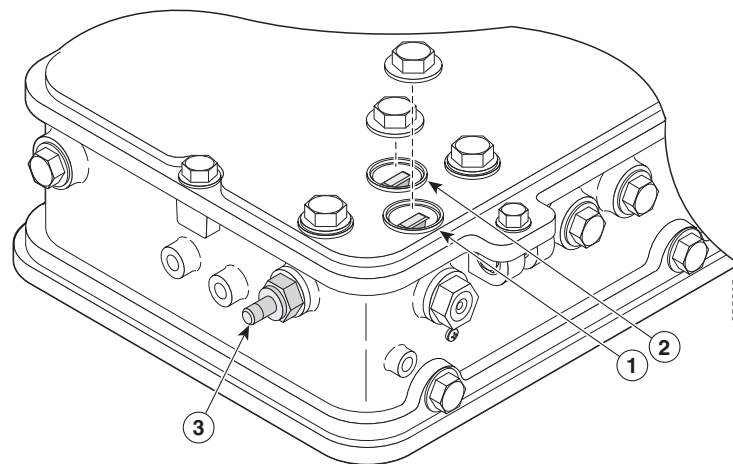

| | | | |
|----------|---|----------|---------------------------|
| 1 | RF splitter attenuator (ATTN) | 2 | RF splitter shunt (SHUNT) |
| 3 | F-connector adapter (stinger connector pin) | | |

Step 5 Use a Phillips screw driver to loosen the set screw, but be careful not to remove it.

- Step 6** Cut the cable stinger connector pin (see [Figure 2-37](#)) to 0.75 ± 0.1 inch (1.91 ± 0.25 cm).

Figure 2-37 Cable Stinger Connector Pin

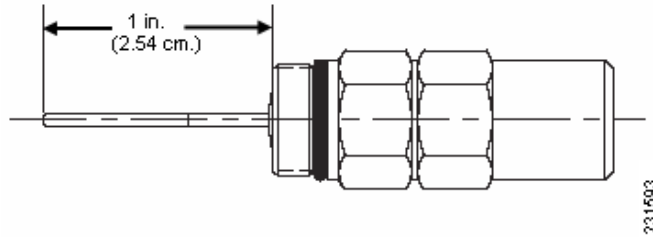

- | | |
|----------|--|
| 1 | Pin length is 0.75 ± 0.1 inch (1.91 ± 0.25 cm). |
|----------|--|

- Step 7** Insert the cable stinger connector pin into the cable POC connector opening in the access point case.
- Step 8** Screw the F-connector adapter into the POC connector opening, and hand-tighten.
- Step 9** Use an adjustable wrench to tighten the F-connector adapter to 6 to 7 ft lbs (8.1 to 9.5 Nm).
- Step 10** Use a Phillips screw driver to tighten the F-connector adapter set-screw on the RF splitter to 2.7 to 3.2 ft lbs (3.66 to 4.34 Nm).
- Step 11** Before connecting cable POC power to the access point, ensure that the antennas are attached to the access point.
- Step 12** Connect or attach the cable company POC cable to the F-connector adapter according to their specifications.
- Step 13** Turn on cable POC power.
- Step 14** Reinsert the RF splitter shunt.
- Step 15** Check the cable modem Power and Cable LEDs and verify that the cable modem receives power and registers to the cable network.

The Power LED (fifth LED from the hinge) is green to indicate power is available. The Cable LED (second LED from the hinge) should be blinking green to indicate scanning the cable network and green to indicate registered on the cable network.

- Step 16** Close the hinged cover (see the [“Closing the Access Point Hinged Cover”](#) section on page 2-31).

Installing the Access Point in Hazardous Locations

This section describes the steps required to retrofit the 1552H access point and prepare it for installation in Class I, Division 2, Zone 2 hazardous locations.



Note

This document does not provide specific procedures for installing conduit. You must ensure that your installation techniques and procedures comply with Class I, Division 2, Zone 2 hazardous location installation regulations for your geographic location.

The access point hazardous location option complies with safety standards for Class I, Division 2, Zone 2 hazardous locations where ignitable concentrations of flammable gases, vapors, or liquids are not likely to exist under normal operation conditions.

When you select the hazardous location option as part of the ordering process, Cisco configures the system to contain the new components. Two conduit adapters and assembly instructions placed in the shipping box provide information and assembly procedures. The hazardous location option configures the access point as follows:

- The battery pack is removed because battery construction does not meet hazardous location requirements.
- Do **not** install the battery (AIR-1520-BATT-6AH=) in the AIR-CAP1552H-x-K9 access point.
- The AC power connections are moved to the inside of the access point by installing an AC entry board containing a terminal block. To comply with hazardous location requirements, AC power must be installed through rigid metal conduit to the terminal block.

 **Caution** Do not use any form of sealant or gasket material when joining conduit components.

 **Caution** The electrical rating for hazardous location installations has a lower voltage rating (100-240 VAC, 50/60 Hz, 1A) than a non-hazardous location installation (100-480 VAC).

 **Note** To provide a proper seal, threaded conduit must be used to route the power and data cabling to the access point.

- Two PG13 - 1/2 NPT adapters are provided. The adapters connect the conduit to the AC power port and Ethernet backhaul port of the access point.
- When used in hazardous locations, the access point is rated 100 to 240 VAC only.

Required Tools and Materials

For a list tools and materials you will need to install the access point, see the [“Package Contents” section on page 2-2](#).

Warnings

 **Warning** Do not disconnect connections to this equipment unless power has been removed or you have verified that the area is nonhazardous. Secure any external connections that mate to this equipment by using screws, sliding latches, threaded connectors, or other means provided with this product. Substitution of components may impair suitability for Class I, Zone 2, Division 2. Statement 1062

 **Warning** When used in a Class I, Zone 2, Division 2 hazardous location, this equipment must be mounted with a proper wiring method that complies with the governing electrical codes. Statement 1069

**Warning**

If you connect or disconnect the console cable with power applied to the unit or any device on the network, an electrical arc can occur. This could cause an explosion in hazardous location installations. Be sure that power is removed or the area is nonhazardous before proceeding.

To verify unit operation, perform POST on the device in a nonhazardous location before installation.
Statement 1080

Compliance

A 1552H access point complies with the following versions of hazardous location certifications:

- IEC 60079-0: 2004
- IEC 60079-15: 2005
- CAN/CSA E60079-0: 2007
- CAN/CSA E60079-15: 2002
- UL 60079-0: Edition 4
- UL 60079-15: Edition 1
- EN 600079-0: 2006
- EN 60079-15: 2006

Compliance Label

Figure 2-38 and Figure 2-39 show examples of a 1552H access point hazardous-location compliance labels.

Figure 2-38 Hazardous-Location Compliance Label for Model AIR-CAP1552H-E-K9

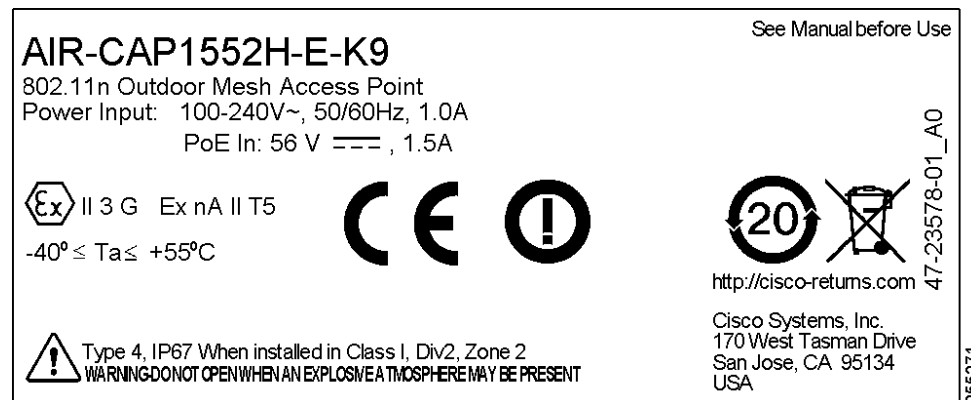

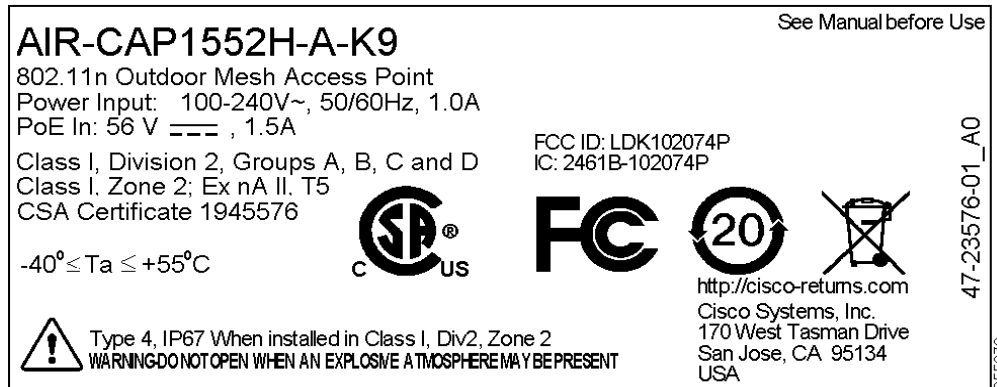

Figure 2-39 Hazardous-Location Compliance Label for Model AIR-CAP1552H-A-K9

Table 2-4 interprets the information on the compliance labels.

Table 2-4 Interpreting the Hazardous Compliance Label

| Label Text | Description |
|--|--|
| Class I, Division 2, Groups A, B, C, D | <p>Defines the environment in which the access point can be used:</p> <ul style="list-style-type: none"> • Class I—Environment containing flammable gases, vapors, or liquids • Division 2—Environmental classification used by the U.S. and Canada • Groups A, B, C, D—Gas identification for the U.S. and Canada: <ul style="list-style-type: none"> - A—Acetylene - B—Hydrogen - C—Ethylene - D—Propane |
| Class I, Zone 2, Group II | <p>Defines the environment in which the access point can be used:</p> <ul style="list-style-type: none"> • Class I—Environment containing flammable gases, vapors, or liquids • Zone 2—Environment classification used in North America • Group II—Gas identification for Zone II, which includes: <ul style="list-style-type: none"> - IIa—Propane - IIb—Ethylene - IIc—Acetylene & Hydrogen |

| Label Text | Description |
|-------------------------|---|
| Ex nA II T5 | <p>Defines parameters that the product complies with for U.S. Certification:</p> <ul style="list-style-type: none"> • Ex —Denotes explosive atmosphere • nA —Non-sparking • II = Group II as defined previously • T5 = Temperature code < 100 degrees C, maximum surface temperature |
| CSA Certificate 1945576 | Identifies the Canadian Standards Association (CSA) certificate number. |
| $-40 \leq Ta < +55C$ | <p>The operating temperature range for the access point in all countries.</p> <div style="border: 1px solid black; padding: 5px; margin-top: 10px;">  <p>Note Current safety certifications only include operation of this outdoor equipment down to -40C.</p> </div> |
| Type 4, IP67 | Defines the enclosure degree of protection (Type 4 = indoor or outdoor use primarily to provide a degree of protection against windblown dust and rain, splashing water, hose-directed water, and damage from external ice formation. IP67 = Dust tight (dust, dirt, sand, and so forth) and protected against powerful water jets. Also, the unit can be immersed in water up to 1m for short periods of time (30min). |

Mounting the Access Point

You can mount the access point using any of the mounting systems described in this document. Follow the instructions in the appropriate section or sections for the installation you intend to use.

Routing and Connecting Ground, AC Power, and Ethernet Backhaul Cables

After you have mounted the access point, you must route ground, AC power, and backhaul Ethernet cabling to the access point using rigid steel conduit.



Note

When you install the conduit, be sure to comply with the local electrical codes for your area.

The procedure is divided into six parts:

1. [“Installing the PG-13 1/2 NPT Conduit Adapters” section on page 2-58](#)
2. [“Opening the 1552H Access Point Hinged Cover” section on page 2-59](#)
3. [“Connecting Ground and AC Power” section on page 2-60](#)
4. [“Closing the 1552H Access Point Hinged Cover” section on page 2-61](#)
5. [“Connecting the Ethernet Backhaul Cable” section on page 2-62](#)

We recommend that you follow these steps in the sequence listed.

Installing the PG-13 1/2 NPT Conduit Adapters

To install the PG-13 1/2 NPT conduit adapters on your access point, follow these steps:

- Step 1** Locate and remove the Ethernet backhaul port plug on the access point, as shown in [Figure 2-40](#).

Figure 2-40 Remove the Ethernet Backhaul Port Plug

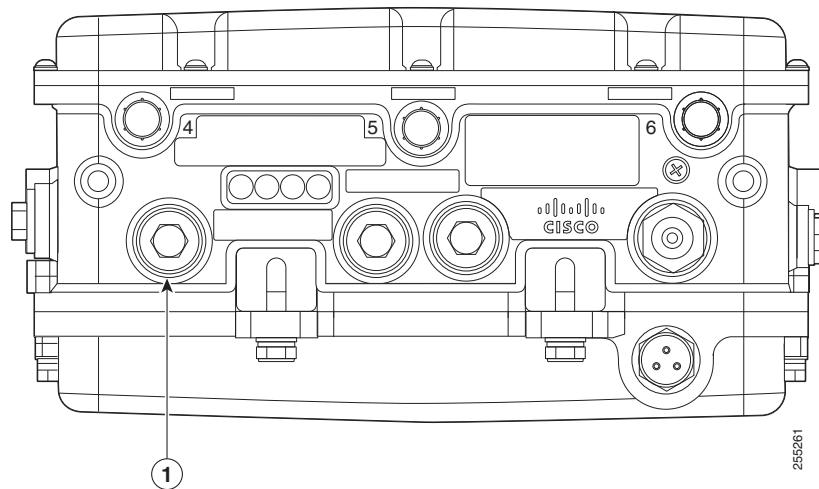

- | | |
|----------|-----------------------------|
| 1 | Ethernet backhaul port plug |
|----------|-----------------------------|

- Step 2** Start a PG-13 1/2 NPT conduit adapter into the threaded hole, as shown in [Figure 2-41](#).

Figure 2-41 Installing the Ethernet Backhaul Cable with Conduit Adapter

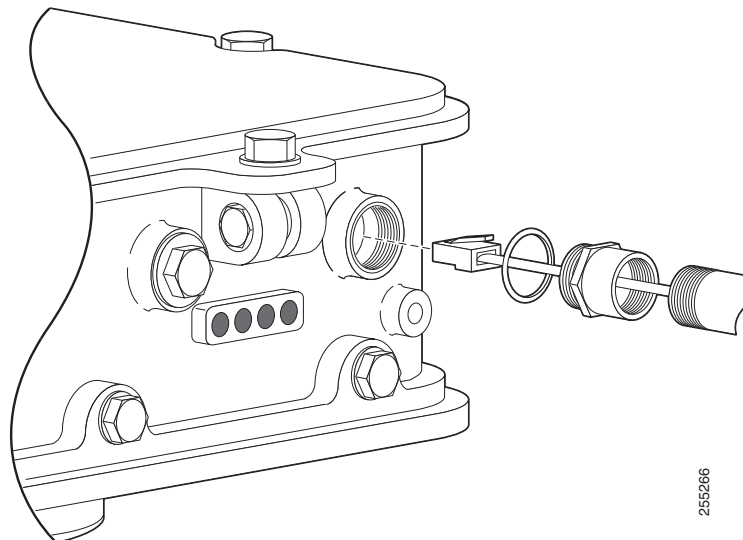

**Caution**

To ensure a proper seal, make sure you have positioned an O-ring on the adapter threads.

**Caution**

Do not use any type of pipe thread sealant or other gasket material. Doing so will invalidate the hazardous-location compliance certification of the unit.

Step 3

Tighten the adapters hand-tight to avoid damaging the O-ring seal.

Opening the 1552H Access Point Hinged Cover

You need to open the 1552H access point hinged cover to access the AC entry terminal block and the Ethernet backhaul port. See [Figure 2-42](#).

To open the access point hinged cover, follow these steps:

Step 1

Use 0.5-in (13-mm) box-end wrench or socket set to unscrew the six bolts on the front cover of the unit. Only unscrew the bolts about 2 turns until they are easily turned by hand, do not remove the bolts.

Step 2

The cover is hinged on the bottom. Carefully open the cover and swing it down.

**Note**

If the cover does not swing open easily, carefully loosen the hinge bolts again.

Figure 2-42 1552H Access Point Front Cover View

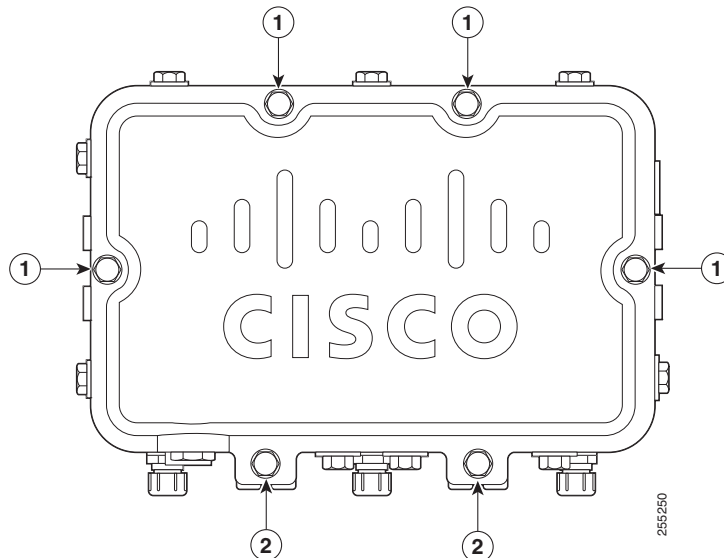

1 M8 x32 bolts

2 Cover hinge M8 x32 bolts

Connecting Ground and AC Power

To route and connect the ground and AC power cabling to the 1552H access point model, follow these steps:

Warning

When installing or replacing the unit, the ground connection must always be made first and disconnected last. Statement 1046

Caution

Always install the ground wire before connecting the AC power leads.

Step 1 Open the access point hinged cover. See the [“Opening the 1552H Access Point Hinged Cover”](#) section on page 2-59 for instructions.

Step 2 Use a Phillips head screwdriver to loosen the three captive screws that secure the AC entry module cover. ([Figure 2-43](#)).

Figure 2-43 AC Power Installation—Model AIR-CAP1552H-A-K9

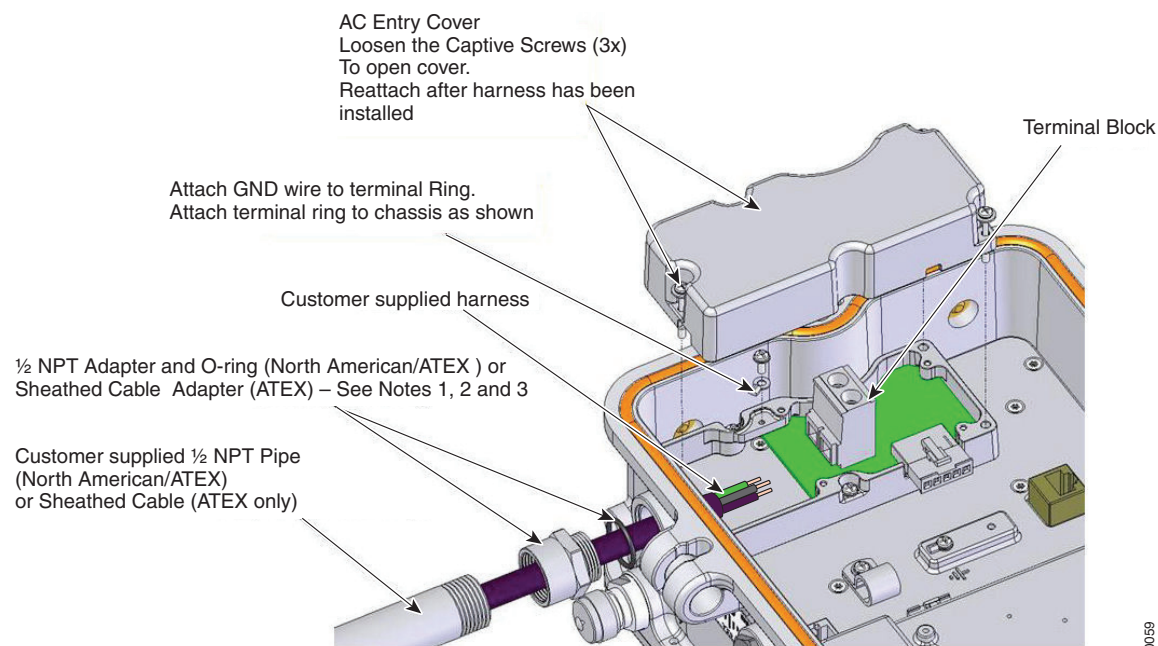

Notes

- 1 The installer/integrator is responsible for supplying the appropriate certified components as part of the overall designed system and must maintain the access point environmental integrity of IP67 rating.
- 2 The water-tight gland device selected by the installer/integrator must be equal to or greater (better) than the specifications listed for device referenced as Sealcon CD-13AR-EX with a Buna-N O-ring.
- 3 The torque specification for water-tight glands are 6 to 7 ft-lbs (8.1 to 9.5 N.m).

- Step 3** Remove the cover and set it aside.
 - Step 4** Route the AC power cable through the PG-13 1/2 NPT adapter serving the AC entry module.
 - Step 5** Use a wire stripper tool to remove the insulation from each wire. Remove only enough wire to provide a solid connection in the terminal block. The hot wires should have no bare wire exposed after the connection is made.
 - Step 6** Insert the ground wire into the provided ground lug and use a crimping tool to secure the connection.
 - Step 7** Install the ground lug and tighten the connection with a Phillips screwdriver. To prevent stripping the screw threads, do not overtighten.
 - Step 8** Insert each hot wire into the AC entry terminal block.
 - Step 9** Use a Phillips screwdriver to tighten the terminal block set screws to secure the wires in the terminal block.
 - Step 10** Verify that no bare wire is exposed. If wire is exposed, remove it from the terminal block, adjust the length, and reinstall.
 - Step 11** Check your work.
 - Step 12** Reinstall the AC entry module top cover and tighten the captive screws. Do not overtighten.
 - Step 13** Close the access point hinged cover. See the [“Closing the Access Point Hinged Cover”](#) section on page 2-31 for details.
 - Step 14** Install the Ethernet backhaul cable. See the next section for instructions.
-

Closing the 1552H Access Point Hinged Cover

To close the 1552H access point cover, follow these steps:

-
- Step 1** When closing the access point cover, be careful not to pinch internal wires.
 - Step 2** Carefully position the cover flush with all sides of the access point, then slowly hand-tighten each bolt.
 - Step 3** When all bolts are hand-tightened, use a 13-mm closed-end wrench or socket to partially tighten the bolts in the tightening sequence shown in [Figure 2-44](#). Tighten each bolt to 3 to 4 ft lbs (0.34 to 0.45 Nm).
 - Step 4** Repeat [Step 3](#) using the same tightening sequence to fully tighten each bolt to 6 to 7 ft lbs (0.68 to 0.79 Nm).

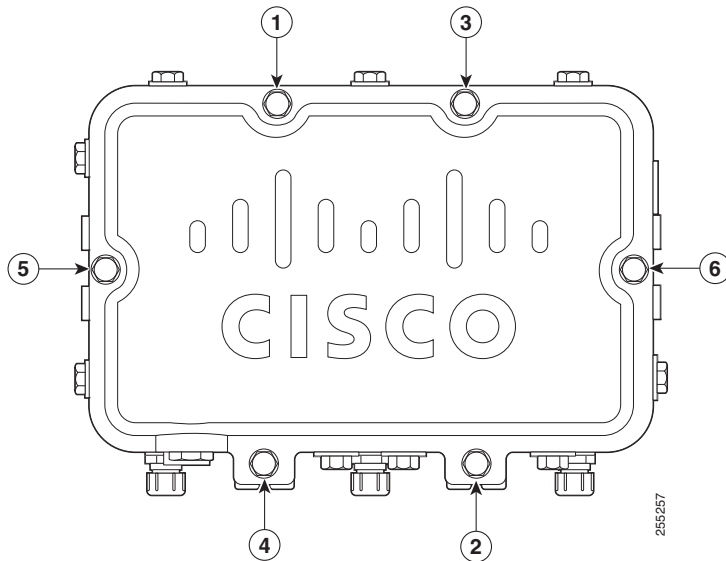
Figure 2-44 Hinged Cover Bolt Tightening Sequence

Connecting the Ethernet Backhaul Cable

The Ethernet backhaul cable plugs into the port identified in [Figure 2-40](#). To connect the Ethernet backhaul cable, follow these steps:

-
- Step 1** Route the Ethernet cable through the PG-13 1/2 NPT serving the backhaul connection on the access point.
 - Step 2** Insert the RJ-45 connector for the cable into the Ethernet connection in the access point. Make sure the connection is tight.
 - Step 3** Check your work.
-

Performing Maintenance

The access point requires minimal periodic or preventive maintenance as it has no moving parts, filters, lubricants, or mechanical contact components. However, when installed in a hazardous location, periodic inspections should be conducted in order to ensure that the access point is operating satisfactory. This section provides information about performing maintenance on an access point installed in a hazardous location.

Additional maintenance information can be found in [Chapter 3, “Troubleshooting”](#) and the *Troubleshooting a Mesh Network Guide*. The troubleshooting document is available at [cisco.com](http://www.cisco.com) at the following URL:

http://www.cisco.com/en/US/docs/wireless/access_point/1520/troubleshooting/guide/TrbleshtMesh.html

**Warning**

Do not disconnect connections to this equipment unless power has been removed or you have verified that the area is nonhazardous. Secure any external connections that mate to this equipment by using screws, sliding latches, threaded connectors, or other means provided with this product. Substitution of components may impair suitability for Class I, Zone 2, Division 2. Statement 1062

**Warning**

If you connect or disconnect the console cable with power applied to the unit or any device on the network, an electrical arc can occur. This could cause an explosion in hazardous location installations. Be sure that power is removed or the area is nonhazardous before proceeding.

To verify unit operation, perform POST on the device in a nonhazardous location before installation. Statement 1080

**Warning**

When installing or replacing the unit, the ground connection must always be made first and disconnected last. Statement 1046

Removing the Access Point from Service

When removing an access point from service, make sure you remove power from the access point before opening the cover and disconnecting the AC input wiring. When removing the AC wiring, the ground connection should be the last to be disconnected.

Conducting Periodic Inspections

The access point should be inspected periodically to ensure normal and airtight operation in the hazardous location environment. [Table 2-5](#) lists the inspection routines and their periodicity.

Table 2-5 *Periodic Inspection Table*

| Inspection Routine | Periodicity |
|---|---------------|
| Inspect O-ring seals and exterior electrical connections for aging, corrosion, and low ground resistance. | Every 3 years |
| Inspect cover and liquid-tight adapter gaskets for airtightness. | Every 5 years |

What to Do Next

When you power up a MAP that is not connected to a wired Ethernet, fiber-optic, or cable network to the controller, the access point uses the Cisco Adaptive Wireless Path Protocol (AWPP) to bind to another mesh access point (MAP) with the best path to a root access point (RAP) connected to the wired network to a controller. The access point sends a discovery request when powered up. If you have configured the access point in the controller correctly, the controller sends back a discovery response to the access point. When that happens, the access point sends out a join request to the controller, and the controller responds with a join confirmation response. Then the access point establishes a Control And Provisioning of Wireless Access Points (CAPWAP) connection to the controller and gets the shared secret configured on the controller.

Refer to the *Cisco Wireless LAN Controller Configuration Guide* for more information on configuring, monitoring, and operating your access points.

