



GETTING STARTED GUIDE



Cisco Aironet 1530 Series Outdoor Mesh Access Points INCLUDING LICENSE AND WARRANTY

Revised October 11, 2013

- 1 [About this Guide](#)
- 2 [Introduction to the Access Point](#)
- 3 [Unpacking the Access Point](#)
- 4 [Radio Configuration](#)
- 5 [Becoming Familiar With the Access Point](#)
- 6 [AP Pole/Wall Mount](#)
- 7 [Preparing the Access Point](#)
- 8 [Deploying the Access Point](#)
- 9 [In Case of Difficulty](#)
- 10 [Declarations of Conformity and Regulatory Information](#)
- 11 [Warranty](#)

1 About this Guide

This guide is designed to familiarize you with your Cisco Aironet 1530 Series Outdoor Mesh Access Point and prepare it for use in your wireless network. For in-depth details on configuring a wireless mesh network, please see:

- *Cisco Mesh Networking Solution Deployment Guide*

Detailed configuration information can also be found in the Cisco wireless LAN controller documentation for the controller and software release you are using. These documents are available on Cisco.com. Follow these steps to access these documents:

-
- Step 1** Browse to <http://www.cisco.com>.
 - Step 2** Click Support. A pop-up window appears.
 - Step 3** Click Wireless under Select a Product Name. The Select Your Product or Technology page appears.
 - Step 4** Click Wireless > Outdoor Wireless.
 - Step 5** Click **Cisco AP 1530 Series** in the Search for a Specific Product field. The Cisco 1530 Series Introduction page appears.
 - Step 6** Choose the appropriate link for the documentation you want to view or download.

General Safety Guidelines

Warnings

Safety warnings appear throughout this guide in procedures that may harm you if performed incorrectly. A warning symbol precedes each warning statement. The warnings below are general warnings that are applicable to the entire guide. Specific warnings are included in the sections to which they apply.



Warning

This warning symbol means danger. You are in a situation that could cause bodily injury. Before you work on any equipment, be aware of the hazards involved with electrical circuitry and be familiar with standard practices for preventing accidents. Use the statement number provided at the end of each warning to locate its translation in the translated safety warnings that accompanied this device.

Statement 1071

SAVE THESE INSTRUCTIONS



Warning

Do not operate the unit near unshielded blasting caps or in an explosive environment unless the device has been modified to be especially qualified for such use.

Statement 364



Warning

This equipment must be externally grounded using a customer-supplied ground wire before power is applied. Contact the appropriate electrical inspection authority or an electrician if you are uncertain that suitable grounding is available.

Statement 366



Warning

Read the installation instructions before connecting the system to the power source.

Statement 1004



Warning

Only trained and qualified personnel should be allowed to install, replace, or service this equipment. **Statement 1030**



Warning

Ultimate disposal of this product should be handled according to all national laws and regulations. **Statement 1040**

2 Introduction to the Access Point

The Cisco Aironet 1530 Series Outdoor Mesh Access Point (hereafter called the *access point* or *AP*) is a rugged outdoor access point designed for service in mesh networks. The 1530 series leverages 802.11n technology with integrated radio and internal/external antennas.

The 1530 contains a 2.4-GHz and 5-GHz radio with an option to configure in centralized, Flexconnect, or mesh mode. The 2.4-GHz radios are used primarily for local access, and the 5-GHz radios can be configured for both local access and/or wireless backhaul in the Mesh mode.

The access point is a standalone unit that can be wall, pole or tower mounted. The access point can also operate as a relay node for other access points not directly connected to a wired network. Intelligent wireless routing is provided by the Adaptive Wireless Path Protocol (AWPP). This enables each access point to identify its neighbors and intelligently choose the optimal path to the wired network by calculating the cost of each path in terms of signal strength and the number of hops required to get to a controller. The access point is configured, monitored, and operated through a Cisco wireless LAN controller (WLC), referred to as a *controller* in this document. The WLC is described in the appropriate *Cisco Wireless LAN Controller Configuration Guide*. The *Cisco Mesh Networking Solution Deployment Guide* describes how to plan and initially configure the Cisco mesh network, which supports wireless point-to-point and point-to-multipoint mesh deployments. The controllers use a browser-based management system, a command-line interface (CLI), or the Cisco Prime Infrastructure (CIP) network management system to manage the controller and the associated access points.

3 Unpacking the Access Point

Follow these steps to unpack the access point:

-
- Step 1** Open the shipping container and carefully remove the contents.
 - Step 2** Return all packing materials to the shipping container and save it.
 - Step 3** Ensure that all items listed in the [“Package Contents” section on page 5](#) are included in the shipment. Check each item for damage. If any item is damaged or missing, notify your authorized Cisco sales representative.
-

Package Contents

Each access point package contains the following items:

- One 1530 series access point
- Two-pin DC power connector
- Ground lug (Panduit PLCD6-10A-L) and screws with lock washers
- Plastic cable gland and rubber seal
- Weatherization tape and anti-corrosion sealant
- Cisco product documentation and translated safety warnings

Optional Equipment

Depending on what you ordered, the following optional equipment may be part of your shipment:

- External antennas, depending on which ones you purchased (see [“1532E Antennas” section on page 6](#) for more information).
- Wall/Pole mount bracket, available as an option or a spare (AIR-ACC1530-PMK1[=])
- Wall/Pole mount bracket with tilt mechanism, spare only (AIR-ACC1530-PMK2=)
- AP cover / Solar Shield for 1532, spare only (AIR-ACC1530-CVR=)
- AC/DC power adapter, spare only (AIR-PWRADPT-1530=)
- Spare Parts kit containing extra cable glands, power connector, ground lug, etc. (AIR-ACC1530-KIT1=)

Antennas

1532I Antennas

- Internal (3/5 dBi)

1532E Antennas

Dual Band Antennas

- AIR-ANT2547V-N (4/7 dBi, OMNI)
- AIR-ANT2547VG-N same as above but gray in color (4/7dBi, OMNI)
- AIR-ANT2588P3M-N= (8/8 dBi, dual polarized patch)

Uni-Band Antennas

2.4 GHz

- AIR-ANT2450V-N= (5 dBi, OMNI)
- AIR-ANT2480V-N= (8 dBi, OMNI)
- AIR-ANT2413P2M-N= (13 dBi, dual polarized patch)

5 GHz

- AIR-ANT5180V-N (8 dBi, OMNI)
- AIR-ANT5114P2M-N= (14 dBi, dual polarized patch)

Non-Cisco Antennas

Cisco does not support any third-party antennas. RF connectivity and compliance of third party antennas is the customer's responsibility. Cisco does not recommend any third-party antennas, and Cisco Technical Assistance Center will not be able to provide any support for third-party antennas. Cisco's FCC Part 15 compliance is only guaranteed with Cisco antennas or antennas that are of the same design and gain as Cisco antennas.

4 Radio Configuration

There are two radio configurations for the 1532 AP radio, the 2-GHz MIMO radio and the 5-GHz MIMO radio. The 2-GHz MIMO radio operates in 2.4 GHz ISM band. It supports up to 13 channels. The 5-GHz MIMO radio operates in the UNII-2 band (5.25 – 5.35 GHz), the UNII-2 Extended/ETSI band (5.47 – 5.725 GHz), and the upper ISM band (5.725 – 5.875 GHz). It supports up to 16 channels.

Refer to the data sheet for the number of channels that are supported for each regulatory domain. For information on the regulatory domains see [“Regulatory Domains” section on page 37](#).

5 Becoming Familiar With the Access Point

The following illustrations show the access point connections. Before you begin the installation process, use these illustrations to familiarize yourself with the access point.



Note The illustrations show all available connections for the configuration ordered. Unused connections are capped with rubber seals to ensure the watertight integrity of the access point. Liquid tight connectors and rubber seals are provided for all ports, which can be installed prior to or after deploying the access point.

Figure 1 and Figure 3 shows the access point bottom and top connectors for model AP 1532I. Figure 2 shows the bottom connectors for model AP 1532E. Figure 4 and Figure 5 show the left and right side connectors for both AP 1532 models.

Figure 1 Access Point Bottom Connectors - AP 1532I

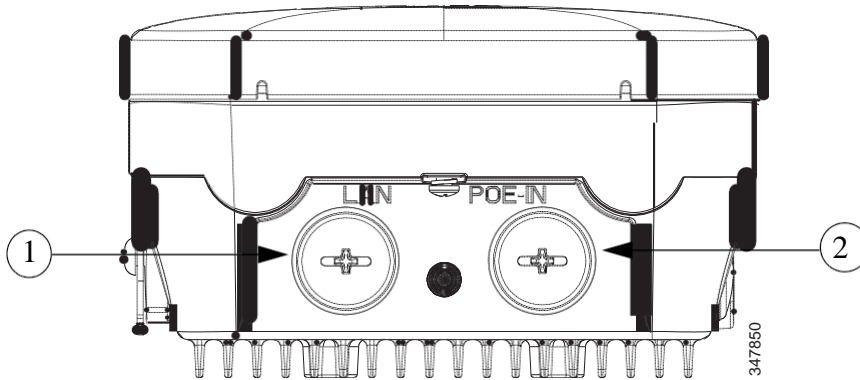

1	LAN port (covered)	2	PoE-in port (covered)
---	--------------------	---	-----------------------

Figure 2 Access Point Bottom Connectors - AP 1532E

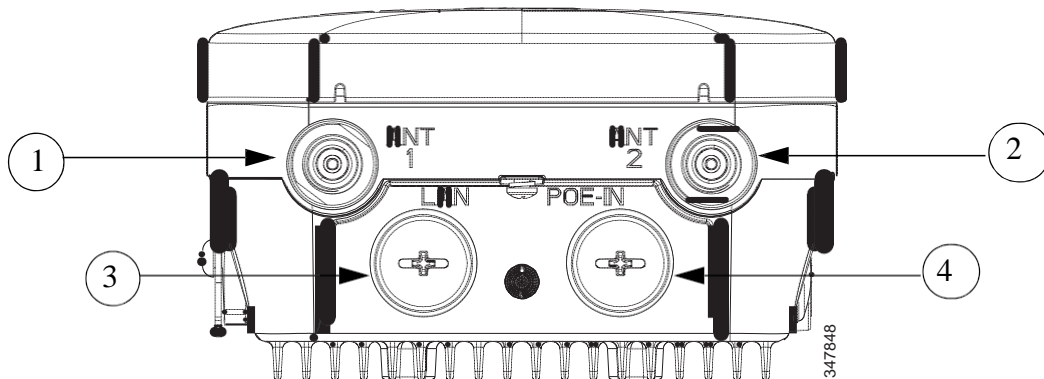

1	Antenna port 1	2	Antenna port 2
3	LAN port (covered)	4	PoE-in port (covered)

Figure 3 Access Point Top Connectors - AP 1532E

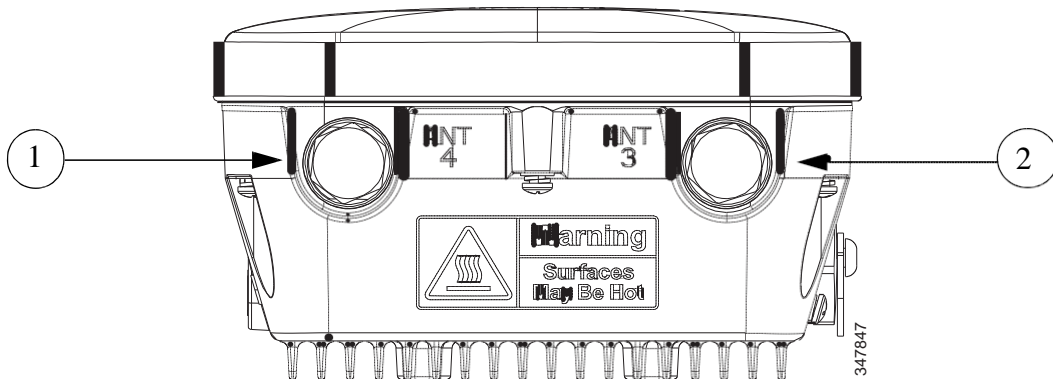

1	Antenna port 4 (covered)	2	Antenna port 3 (covered)
----------	--------------------------	----------	--------------------------

Figure 4 Access Point Left Side Connectors - Both AP 1532 Models

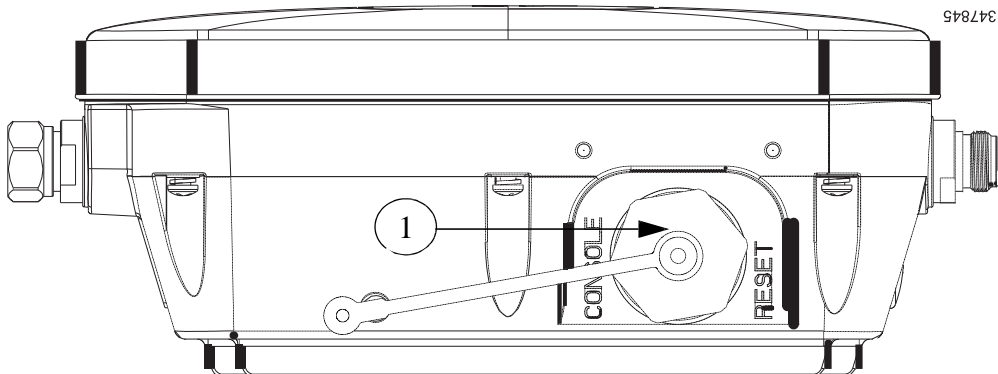

1	Console Port and Reset button (covered)	
---	---	--

Figure 5 Access Point DC Power Connector and Ground Lug (Both AP 1532 Models)

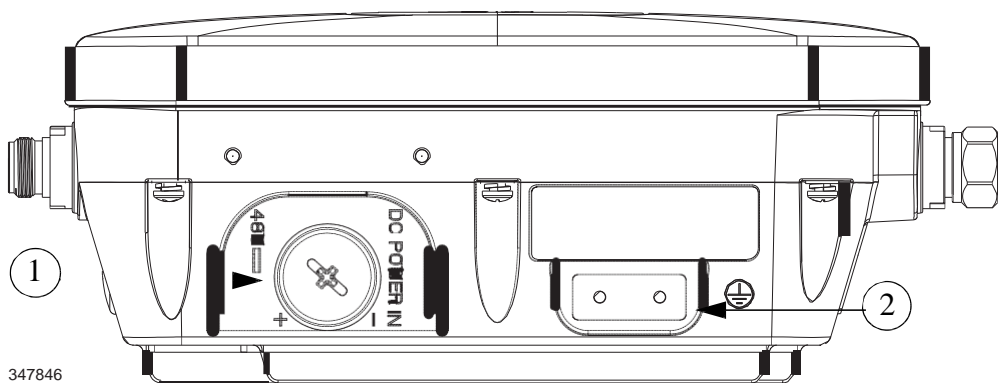

1	DC power port (covered)	2	Ground lug location
---	-------------------------	---	---------------------

Radio Operation and Antennas

AP 1532I

The AP 1532I uses an Integrated Low Profile Dual-Band 2.4/5 GHz Dipole Antenna Array. The antenna contains an array of three dual-band dipole antennas. The three dipole antennas are contained within this single radome, thereby greatly reducing the antenna’s visual footprint, and greatly reducing the possibility of snagging the antenna on the cable bundle, the RF cable, or test cables. The antennas operate over both 2.4 GHz and 5.25 – 5.85 GHz bands. Each of the three dipole antennas is a dual-band antenna, covering both the 2.4 – 2.483 GHz band, and the 5.25 – 5.85 GHz bands. The antennas have a peak gain of about 2 dBi at 2.4 GHz and 4 dBi at 5 GHz. The antenna unit is gray weatherproof radome for outdoor operation.

The 1532I access point 802.11b/g/n radio is used primarily for local access and its 802.11a/n radio for wireless backhaul in the Mesh.

The 2-GHz b/g/n radio operates in 2.4 GHz ISM band. It supports channels 1-11 in US, 1-13 in Europe, and 1-13 in Japan. It has three transmitters with a maximum total output power of 29dBm for 802.11b/g/n operation. Output power is configurable to 5 levels. It has three receivers that enables maximum-ratio combining (MRC).

The 5-GHz a/n radio operates in the UNII-2 band (5.25 - 5.35 GHz), UNII-2 Extended/ETSI band (5.47 - 5.725 GHz), and the upper ISM band (5.725 - 5.850 GHz). It has two transmitters with a maximum total output power of 29 dBm for UNII-2 and Extended/ETSI bands for the A-domain. The total maximum output power for the upper ISM band is 28 dBm for A-domain. Tx power settings will change depending on the regulatory domain. Output power is configurable for 5 power levels in 3 dB steps. Its three receivers enable maximum-ratio combining (MRC).

The 1532I access point is equipped with three integrated dual-band antennas with 3 dBi gain at 2 GHz and 5 dBi at 5 GHz.



Warning

Only trained and qualified personnel should be allowed to install, replace, or service this equipment.

Statement 1030

AP 1532E

The 1532E is equipped with two N-type radio frequency (RF) connectors (antenna ports 1 and 2) on the bottom of the unit for external antennas to support multiple input multiple output (MIMO) operation in dual-band mode, as shown in Figure 6. The 1532E must always be operated with the two external antennas attached. When using the Cisco Aironet AIR-ANT2547V-N Dual-Band Omnidirectional Antenna, the 2.4- and 5-GHz antennas connect directly to the access point, as shown in Figure 7. If the antennas are remotely located, an appropriate low-loss RF coax cable should be used.

The 1532E access points are equipped with 4 N-type radio frequency (RF) connectors (antenna ports 1 and 2 on the bottom of the unit for 2-GHz and antenna ports 3 and 4 on the top of the unit for 5-GHz) for external antennas to support multiple input multiple output (MIMO) operation. The antenna ports located on top of the 1532E are shown in Figure 3. The 1532E must always be operated with the appropriate external antennas attached. Ports 1 and 2 can be used for Dual Band operation with a software configuration.



The antenna port caps must be removed for a uni-band antenna installation, but ports 3 and 4 should remain capped for a dual-band antenna installation to provide an IP67 seal.

Figure 6 Access Point Bottom External Antenna Connectors - AP 1532E

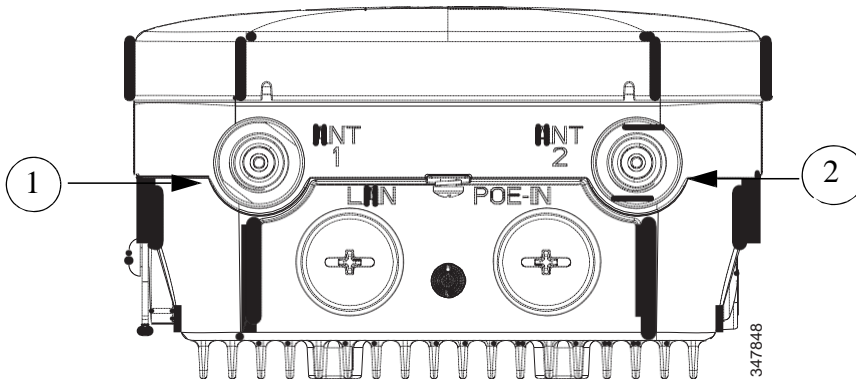

1	N-Type Connector - Antenna port 4 (Tx/Rx)	2	N-Type Connector - Antenna port 6 (Tx/Rx)
---	---	---	---

Antenna Mounting Configurations

The selection of the antenna is determined in the configuration of the product. The 1532E antennas can be mounted on a wall, pole and/or tower mounted. See [Antennas, page 6](#) for a list of supported antennas.

Figure 7 Access Point Dual-Band Omnidirectional Antennas - Installed Only on AP 1532E

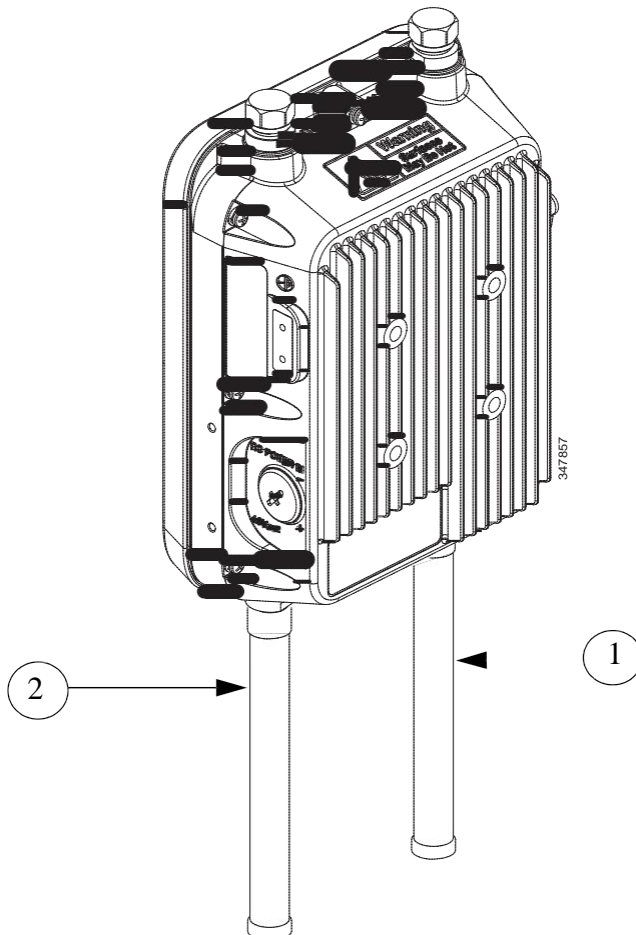

1	Antenna connected to antenna port 1 (Type-N connector) (TX/RX)	2	Antenna connected to antenna port 2 (Type-N connector) (TX/RX)
----------	--	----------	--

**Note**

The FCC limits the amount of power this device can transmit. Power transmitted is a combination of the amplification of the signal and the antenna gain. The access point has been designed to operate with the Cisco provided antennas.

Power

**Warning**

Installation of the equipment must comply with local and national electrical codes. Statement 1074

**Warning**

This equipment must be externally grounded using a customer-supplied ground wire before power is applied. Contact the appropriate electrical inspection authority or an electrician if you are uncertain that suitable grounding is available. Statement 366

**Warning**

Do not work on the system or connect or disconnect cables during periods of lightning activity. Statement 1001

The 1532E access point supports these power sources:

- DC power—48 volt
- Power-over-Ethernet (PoE)—56 VDC power injector (AIR-PWRINJ1500-2=)

**Caution**

Do not place the power injector in an unprotected outdoor environment because water could get into the power injector and cause a short circuit and possible fire.

**Warning**

Connect the unit only to DC power source that complies with the Safety Extra-Low Voltage (SELV) requirements in IEC 60950 based safety standards Statement 1033

Power Injectors

The 1530 Series Access Points support the following power injectors:

- AIR-PWRINJ1500-2= — 100-240 VAC input, indoor use only
- AIR-PWRINJ4= — 100-240 VAC input, indoor use only (for the 1532E only)

Warning
cord.

To reduce the risk of fire, use only No. 26 AWG or larger telecommunication line

Statement 1023



Caution

To provide inline PoE, you must use the 1500 power injector (listed above). Other power injectors, PoE switches, and 802.3af power sources cannot provide adequate power, which may cause the access point to malfunction and cause over-current conditions at the power source. You must ensure that the switch port connected to the access point has PoE turned off.



Caution

The 1500 power injector (AIR-PWRINJ1500-2=) and the AIR-PWRINJ4= must be used in an indoor environment only.



Caution

When the access point is installed outdoors or in a wet or damp location, the AC branch circuit that is powering the access point should be provided with ground fault protection (GFCI), as required by Article 210 of the National Electrical Code (NEC).

Ethernet (PoE) Ports

The access point supports an Ethernet uplink port (PoE-In). The access point Ethernet uplink port uses an RJ-45 connector (with weatherproofing) to link the access point to the 10BASE-T, 100BASE-T or 1000BASE-T network. The Ethernet cable is used to send and receive Ethernet data and to optionally supply inline 56-VDC power from the power injector.



Tip

The access point senses the Ethernet and power signals and automatically switches internal circuitry to match the cable connections.



Warning cord.

To reduce the risk of fire, use only No. 26 AWG or larger telecommunication line

Statement 1023

The Ethernet cable must be a shielded outdoor rated Category 5e (CAT5e) or better cable. The access point senses the Ethernet and power signals and automatically switches internal circuitry to match the cable connections.

6 AP Pole/Wall Mount

This section provides instructions for installing your access point(s). Personnel installing the access point(s) must understand wireless access points and bridging techniques and grounding methods.



Caution

All installation methods for mounting an access point on any wall surface is subject to the acceptance of local jurisdiction.

Installation Options

The 1530 Series Access Point can be wall, pole or tower mounted. There are two optional mounting kits: a fixed mounting kit (AIR-ACC1530-PMK1=) and a pivoting mounting kit (AIR-ACC1530-PMK2=).



Warning

Only trained and qualified personnel should be allowed to install, replace, or service this equipment. Statement 1030



Warning

Installation of the equipment must comply with local and national electric codes. Statement 1074

When mounting an access point on a horizontal or vertical surface, you must ensure that the access point is oriented with the LED indicators pointing down (see [Figure 10 on page 33](#)). This positioning allows LEDs to be visible to someone on the ground below the access point.

You must also ensure the access point is mounted in such a way as to ensure that all antenna ports and the console port are accessible for future use.

Wall Mounting the Access Point with the Fixed Mounting Kit

The optional fixed mounting kit contains a mounting bracket for wall mounting or pole mounting. You can use the mounting bracket as a template to mark the positions of the mounting holes for your installation. You then install the mounting plate, and attach the access point when you are ready. [Table 1](#) lists the materials you will need to provide in addition to the fixed mounting kit.

Table 1 Material Needed to Mount Access Point to a Vertical Wall

Materials Required	In Kit
Ground lug and screws (provided with access point)	Yes
Wall Mount Bracket	Yes
Four M6 x 12-mm Hex-head Bolts	Yes
Two stainless steel band clamps (adjustable 2"–5", 51 mm – 127 mm)	Yes
Two stainless steel band clamps(adjustable 5"–8", 127 mm – 203 mm)	Yes
Crimping tool for ground lug, Panduit CT0720 with CD-720-1 die (http://onlinecatalog.paduit.com)	No
Four wall mounting screws	No
Four wall anchors (specified for all material)	No
Drill bit for wall anchors	No
Electric drill and standard screwdriver	No
#6 AWG ground wire	No
Shielded outdoor-rated Ethernet (CAT5e or better) cable	No
Grounding block	No
Grounding rod	No
10-mm box-end wrench or socket set	No



Caution

The mounting surface, attaching screws and optional wall anchors must be able to support a 50-lb (22.7 kg) static weight.

To mount the access point on a vertical wall, follow these instructions:

Step 1 Use the mounting bracket as a template to mark four screw hole locations on the mounting surface. See [Figure 8](#) for the mounting bracket screw hole locations. Use the mounting slotted holes to attach the unit to the wall.

Figure 8 Mounting Bracket for Wall or Pole Mounting

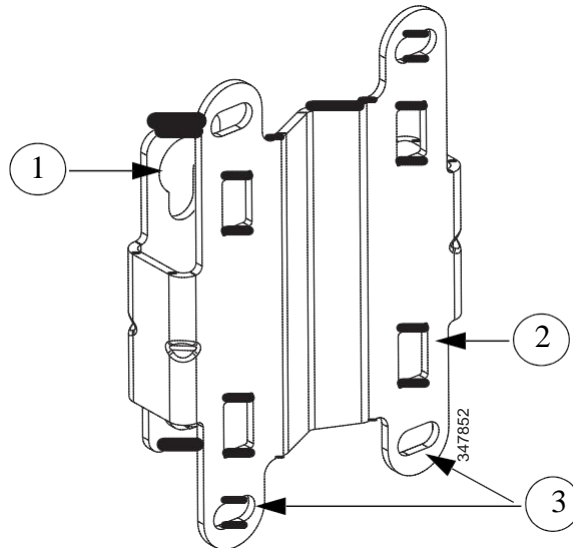

1	Quick Mount Keyhole Slots (for AP use)	2	Mounting Slots (used with the band clamps)
3	Bracket Mount Holes (use bolts up to 1/4" or 6 mm in diameter)		

Step 2 Use four customer-supplied screws and optional screw-anchors to attach the mounting plate to the mounting surface.



Note If necessary, use suitable screw anchors and an exterior-grade plywood backboard to mount the access point to stucco, cement or drywall.

Step 3 Screw an M6 x12 mm bolt into each of the four support bolt holes on the back of the access point. Do not screw the bolt all the way in; leave approximately a 0.13 inch (3.3 mm) space.

Step 4 Position the four bolts on the access point into the keyhole slots on the mounting bracket.

Step 5 Slide the access point down to sit securely in the quick mount notches.

Step 6 Using a 10mm wrench, secure the AP to the bracket by tightening the bolts to the bracket; torque to 40 in-lbf.

Step 7 Continue with the [Grounding the Access Point, page 23](#).

Pole Mounting the Access Point with the Fixed Mount Kit

The optional fixed mounting kit contains a mounting bracket for wall mounting or pole mounting. This kit can be used to install the access point on a pole, mast or streetlight. It supports metal, wood or fiberglass poles from 2 to 8 inches in diameter.

Table 2 Materials Needed to Mount the AP on a Vertical Pole

Materials Required	In Kit
One wall mount bracket	Yes
Four M6 x12mm hex head bolts	Yes
Two stainless steel band clamps (adjustable 2"–5", 51–127 mm)	Yes
Two stainless steel band clamps (adjustable 5"–8", 127–203 mm)	Yes
10 mm box-end wrench	No
Outdoor rated shielded ethernet cable	No
Ground lug (provided with the access point)	Yes
Ground block and rod	No
Crimping tool for ground lug, Panduit CT-720 with CD-720-1 die (http://onlinecatalog.panduit.com)	No
#6 AWG ground wire	No

To mount the access point onto a vertical pole or streetlight pole, follow these steps:

Step 1 Select a mounting location on the pole to mount the access point. You can attach the access point to any pole with a diameter from 2 to 8 inches (5.1 to 20.1 cm).



Note

If you will be using a streetlight power tap adapter, position the access point within 3 ft (1 m) of the outdoor light control. The AC/DC adapter must be used with street light power tap.

- Step 2** Determine which size of band clamp is needed based on the pole diameter. Slide the two clamps through the top and bottom set of mounting slots (see [Figure 8](#)) and mount the bracket to the pole.
- Step 3** Wrap the band clamps around the pole and slide them into the second set of top and bottom mounting slots on the bracket. Lightly tighten the clamps. Only tighten them enough to keep the bracket from sliding down the pole.
- Step 4** Screw an M6 bolt into each of the four bolt holes on the back side of the access point. Do not screw the bolt in all the way. Leave a gap of about 0.13" (3.3mm).
- Step 5** Position the four bolts on the access point into the bracket keyhole slots. Check to be sure that the access point is properly seated in the slots.(See [Figure 9](#))



Note

The access point should be positioned with the LEDs on the bottom to allow viewing from the ground.

- Step 6** Using a 10mm wrench, tighten the four bolts that connect the access point to the bracket to a torque of 40 in-lbf.
- Step 7** Locate the access point to its final position. Tighten the band clamps with the wrench so that the access point does not slide on the pole. Be sure that the clamps are tight enough that the AP does not move.
- Step 8** Continue with the [Grounding the Access Point, page 23](#).

Figure 9 AP and Fixed Mount Kit Installed on a Pole

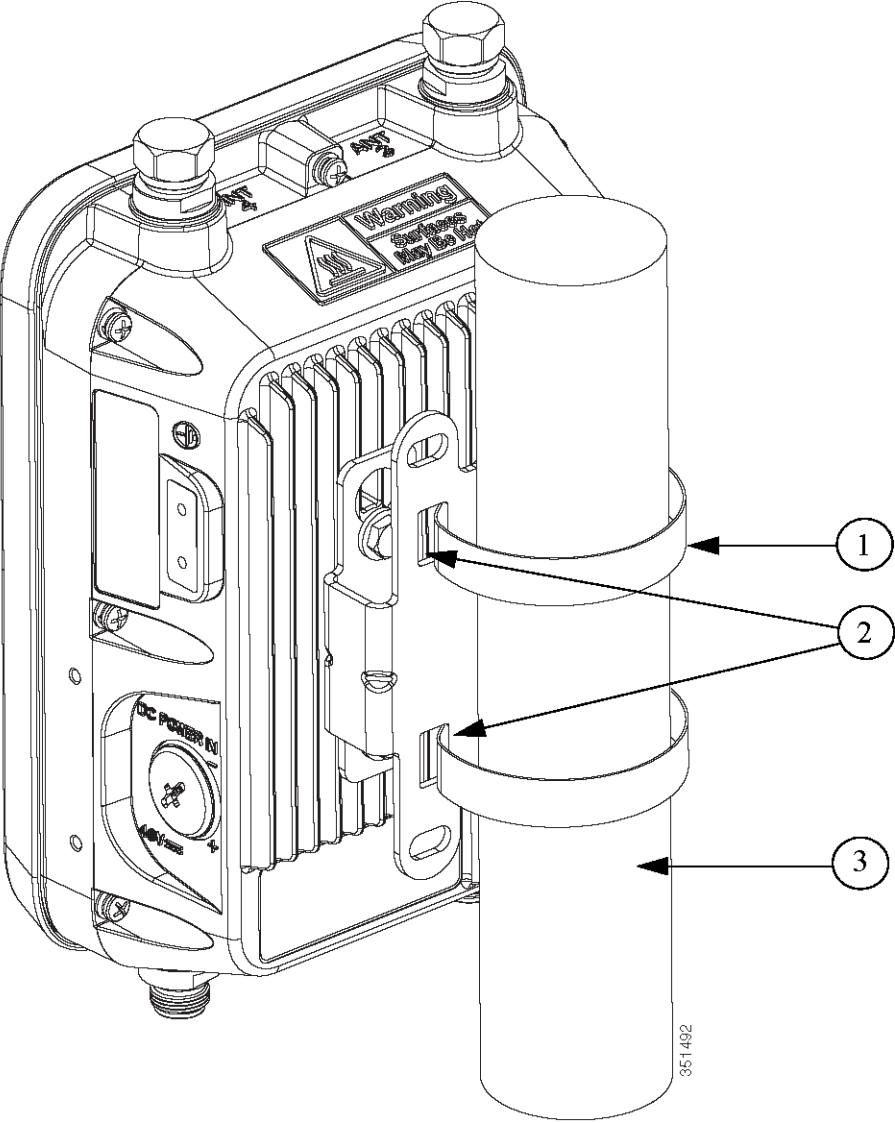

1	Metal Band Strap	2	Mounting Slots
3	Pole		

Grounding the Access Point

The access point must be grounded before connecting power.



Warning

This equipment must be externally grounded using a customer-supplied ground wire before power is applied. Contact the appropriate electrical inspection authority or an electrician if you are uncertain that suitable grounding is available. Statement 366



Warning

Installation of the equipment must comply with local and national electrical codes. Statement 1074

In all outdoor installations and when powering the access point with AC power, you must follow these instructions to properly ground the access point:

-
- Step 1** If using insulated 6-AWG copper ground wire, strip the insulation as required for the grounding lug.
 - Step 2** Use the appropriate crimping tool to crimp the bare 6-AWG copper ground wire to the supplied grounding lug.



Note

The grounding lug and hardware used must comply with local and national electrical codes.

- Step 3** Open the electrical joint compound (supplied), and apply a liberal amount over the metal surface where the ground strap screw holes are located (see [Figure 5](#)).
- Step 4** Connect the grounding lug to the access point grounding screw holes (see [Figure 5](#)) using the supplied two Phillips head screws (M4 x 10 mm) with lock washers. Tighten the grounding screw to 22 to 24 in. lbs (2.49 to 2.71 Nm).
- Step 5** If necessary, strip the other end of the ground wire and connect it to a reliable earth ground, such as a grounding rod or an appropriate grounding point on a metal streetlight pole that is grounded.

7 Preparing the Access Point

The access point is a radio device which is susceptible to common causes of interference that can reduce throughput and range. Follow these basic guidelines to ensure the best possible performance:

- For information on planning and initially configuring your Cisco mesh network, refer to the *Cisco Wireless Mesh Access Points, Design and Deployment Guide, Release 7.6*. These documents are available on cisco.com.
- Do not install the access point in an area where structures, trees, or hills obstruct radio signals to and from the access point.
- You can install the access point at any height, but best throughput is achieved when the access points are mounted at the same height.



Note

To perform path loss calculation and to determine how far apart to install access points, consult an RF planning expert.



Note

See the 1530 Series Hardware Installation Guide for information on conducting a site survey prior to installing the access point.

Avoiding Damage to Radios in a Testing Environment

The radios on outdoor units (bridges) have higher transmit power levels than radios on indoor units (access points). When you test radios in a link, you must avoid exceeding the maximum receive input level of the receiver. At levels higher than the normal operating range and packet error rate (PER) performance of the receiver is degraded. At even higher levels, the receiver can be permanently damaged.

To avoid receiver damage and PER degradation, you can use one of the following techniques:

- Separate the omnidirectional antennas by at least 2 ft (0.6 m) to avoid receiver damage or by at least 25 ft (7.6 m) to avoid PER degradation.
- Reduce the configured transmit power to the minimum level.
- Cable the radios together using a combination of attenuators, combiners, or splitters to achieve a total attenuation of at least 60 dB.

For a radiated test bed, the following equation describes the relationships among transmit power, antenna gain, attenuation, and receiver sensitivity:

$$\text{txpwr} + \text{tx antenna gain} + \text{rx ant gain} - [\text{attenuation due to antenna spacing}] < \text{max rx input level}$$

Where:

txpwr = Radio transmit power level
tx gain = transmitter antenna gain
rx gain = receiver antenna gain

For a conducted test bed, the following equation describes the relationships among transmit power, antenna gain, and receiver sensitivity:

$$\text{txpwr} - [\text{attenuation due to coaxial RF Attenuator components}] < \text{max rx input level} \\ (0 \text{ dbm})$$



Caution

Under no circumstances should you connect the antenna port from one access point to the antenna port of another access point without using an RF attenuator. If you connect antenna ports you must not exceed the maximum survivable receive level of 0 dBm. Never exceed 0 dBm or damage to the access point can occur. Using attenuators, combiners, and splitters having a total of at least 60 dB of attenuation ensures that the receiver is not damaged and PER performance is not degraded.

Before You Begin



Warning

Read the installation instructions before connecting the system to the power source.
Statement

1004

Before you begin the installation process:

- Become familiar with the procedures for mounting the access point (see the [AP Pole/Wall Mount](#), page 17).
- Become familiar with the access point connections ([Figure 1 on page 8](#), [Figure 4 on page 10](#), and [Figure 5 on page 10](#)).
- Verify that the switch you are using to connect the controller is configured properly.

8 Deploying the Access Point

The following portions of this manual address how to deploy the Access Point. There are several deployment methods.

Warning Do not operate the unit near unshielded blasting caps or in an explosive environment unless the device has been modified to be especially qualified for such use. Statement 364

Controller-based Deployments

The access point is deployed on Layer 3 networks. Layer 3 is the default mode for a newly configured wireless LAN controller. This guide assumes that you will be deploying your access point on a Layer 3 network and a DHCP server is available.

Before deploying the access point, make sure the controller to which the access point will associate is properly configured by performing the following operations:

- Verify the wireless LAN controller software version
- Record the access point BVI MAC address (MAC address is located on the label on the side of the unit.)
- Enter the access point BVI MAC address to the wireless LAN controller filter list

Recording the Access Point MAC Address

Use a text file to record the MAC address of all the access points you intend to deploy in your network. Having a file of the access point MAC addresses will be of considerable value for future testing. While you are compiling the list, you might want to change the name of the access point to something you can easily remember. The name can contain up to 32 characters. The following example, *fisher_street:ea:co* contains the last four HEX characters of the access point MAC address.

Adding the Access Point MAC Address to the Wireless LAN Controller Filter List

The wireless LAN controller maintains an access point authorization MAC address list and responds to discovery requests from access points on that list. To add the access point MAC address (or MAC addresses) to the Wireless LAN controller filter list, follow these steps:

-
- Step 1** If you are not logged onto the wireless LAN controller, log on now. The Summary page appears.
 - Step 2** On the menu bar, click **SECURITY**. The Security RADIUS Authentication Server page appears.
 - Step 3** Under AAA in the left frame, click **MAC Filtering**. The Security MAC Filtering page appears.
 - Step 4** Click **New**. The MAC Filters New page appears.
 - Step 5** Enter the MAC address of the access point in the MAC Address field. You can also use the **config macfilter add** command to add a MAC filter entry to the controller.
 - Step 6** Select a WLAN ID or **Any WLAN** from the WLAN ID pop-up menu.
 - Step 7** Enter a description (32 characters maximum) of the access point in the Description field.
 - Step 8** Choose an interface from the Interface Name pop-up menu.
 - Step 9** Click **Apply**.
 - Step 10** Repeat this process to add other access points to the list.



Note You can also use the controller CLI command **config macfilter add** to add a MAC filter entry on the controller.

- Step 11** On the menu bar, click **Monitor** to return to the Monitor Summary page.
-

Verifying Controller Association

To verify that your access point is associated to the wireless LAN controller, perform these steps:

-
- Step 1** Log into your controller web interface (https) using a web browser.
 - Step 2** Click **Wireless** and verify that your access point MAC address is listed under Ethernet MAC.
 - Step 3** Log out of the controller and close your web browser.
-

Deployment Notes

Using a DHCP Server in a Layer 3 Mesh Network

To use a DHCP server in a Layer 3 mesh network, you must configure DHCP option 43 on the DHCP server. After the controller is restarted, the access point receives IP addresses from the DHCP server.

Configuring DHCP Option 43

You can use DHCP Option 43 to provide a list of controller IP addresses to the access points, enabling each access point to find and join a controller. This section contains a DHCP Option 43 configuration example on a Microsoft Windows 2003 Enterprise DHCP server for use with Cisco Aironet lightweight access points.

Additional information about Microsoft DHCP Option 43 is available on Cisco.com at the following URL:

http://www.cisco.com/en/US/tech/tk722/tk809/technologies_configuration_example09186a00808714fe.shtml

DHCP Option 43 server implementation information for Cisco IOS is available at cisco.com at the following URL:

<http://www.cisco.com/en/US/docs/wireless/technology/controller/deployment/guide/dep.html#wp1068287>



Note In DHCP Option 43, you should use the IP address of the controller management interface.



Note DHCP Option 43 is limited to one access point type per DHCP pool. You must configure a separate DHCP pool for each access point type.

Cisco 1532 access points use the type-length-value (TLV) format for DHCP Option 43. DHCP servers must be programmed to return the option based on the DHCP Vendor Class Identifier (VCI) string (DHCP Option 60) of the access point. The VCI string for the Cisco 1532 access point is Cisco AP c1532.

The format of the TLV block for the 1532 access point is listed below:

- Type: 0xf1 (decimal 241)
- Length: Number of controller IP addresses * 4
- Value: List of WLC management interfaces

Configuring Option 43 for Cisco 1532 Access Points

To configure DHCP Option 43 for Cisco 1532 access point in the embedded Cisco IOS DHCP server, follow these steps:

Step 1 Enter configuration mode at the Cisco IOS CLI.

Step 2 Create the DHCP pool, including the necessary parameters such as default router and name server. The commands used to create a DHCP pool are as follows:

```
ip dhcp pool pool name
network IP Network Netmask
default-router Default router
dns-server DNS Server
```

Where:

pool name is the name of the DHCP pool, such as AP1532.

IP Network is the network IP address where the controller resides, such as 10.0.15.1

Netmask is the subnet mask, such as 255.255.255.0

Default router is the IP address of the default router, such as 10.0.0.1

DNS Server is the IP address of the DNS server, such as 10.0.10.2

Step 3 Add the Option 60 line using the following syntax:

```
option 60 ascii "VCI string"
```

For the VCI string, use the value from [Configuring DHCP Option 43, page 28](#). The quotation marks must be included.

Step 4 Add the option 43 line using the following syntax:

```
option 43 hex hex string
```

The hex string is assembled by concatenating the TLV values shown below:

Type + Length + Value

Type is always *f1(hex)*. *Length* is the number of controller management IP addresses times 4 in hex.

Value is the IP address of the controller listed sequentially in hex.

For example, suppose that there are two controllers with management interface IP addresses, 10.126.126.2 and 10.127.127.2. The type is *f1(hex)*. The length is $2 * 4 = 8 = 08$ (*hex*). The IP addresses translate to *0a7e7e02* and *0a7f7f02*. Assembling the string then yields *f1080a7e7e020a7f7f02*. The resulting Cisco IOS command added to the DHCP scope is listed below:

```
option 43 hex f1080a7e7e020a7f7f02
```

Autonomous Mode Configuration

The 1530 Series allows the Unified (controller-based) and Autonomous mode software to be loaded at the factory on the same hardware part number. This eliminates the need for separate part numbers for controller-based units and autonomous mode units.

At boot-up, the default mode is controller-based. The 1530 will power up and begin searching for a controller. Once it joins the controller, it will download the active Unified image from the controller. This is the same operation as other Cisco controller-based APs.

For Autonomous mode, the user should take the following steps:

Step 1 Power the AP and connect to the console.

Step 2 From the Command Line, enter:

```
AP # capwap ap autonomous (# means privileged EXEC mode)
```

Step 3 The system will respond with "Convert to Autonomous image. Proceed? (yes/[No]):"

Step 4 Type "yes" to confirm.

Step 5 The AP will then re-boot and load the Autonomous image. The unified image is erased.

Step 6 Once the 1530 has booted in autonomous mode, configuration of the AP can be done by following the procedure outlined here:

http://www.cisco.com/en/US/partner/docs/wireless/access_point/12.4_10b_JA/configuration/guide/scg12410b.html

9 In Case of Difficulty

Help is available from Cisco should you experience difficulties; however, before contacting Cisco, look for a solution to your problem in the following places:

- The Troubleshooting section of this guide
- The *Troubleshooting a Mesh Network* troubleshooting guide found on cisco.com at http://www.cisco.com/en/US/products/ps8368/prod_troubleshooting_guides_list.html
- The Tools and Resources section on the Technical Support and Documentation page at cisco.com

Follow these steps to contact the Technical Assistance Center on cisco.com:

-
- Step 1** Open your browser and go to <http://www.cisco.com/>.
- Step 2** Click **Support**. The Support page appears.
- Step 3** Choose the link that best serves your support requirements.



Note Click **My Tech Support** if you are a registered user.

- Step 4** Follow the instructions on the page.
-

Troubleshooting



Caution No serviceable parts inside. Do not open.

This section provides troubleshooting procedures for basic problems with the access point. For the most up-to-date, detailed troubleshooting information, refer to the Cisco Support website at cisco.com.

Guidelines for Using the Access Point

You should keep these guidelines in mind when you use the access point:

- The access point supports Layer 3 CAPWAP communications with the controllers. In Layer 3 operation, the access point and the controller can be on the same or different subnets. The access point communicates with the controller using standard IP packets. Layer 3 operation is scalable and is recommended by Cisco. Unless it has a static IP address, a Layer 3 access point on a different subnet than the controller requires a DHCP server on the access point subnet and a route to the controller. The route to the controller must have destination UDP ports 12222 and 12223 open for CAPWAP communications. The routes to the primary, secondary, and tertiary controllers must allow IP packet fragments.
- Before deploying your mesh access points ensure that the following has been done:
 - Your controllers are connected to switch ports that are configured as trunk ports.
 - Your mesh access points are connected to switch ports that are configured as untagged access ports.
 - A DHCP server is reachable by your mesh access points and has been configured with Option 43. Option 43 is used to provide the IP addresses of the Management Interfaces of your controllers. Typically, a DHCP server can be configured on a Cisco Layer 3 switch or router.
 - Optionally a DNS server can be configured to enable a local domain Cisco CAPWAP controller (CISCO-CAPWAP-CONTROLLER.<local domain>) to resolve to the IP address of the Management Interface of your controller.
 - Your controllers are configured and reachable by the mesh access points.
 - Your controllers are configured with the MAC addresses of the mesh access points.

Checking the LEDs

One LED is located between the LAN and PoE-In connectors. It indicates the status of the access point power, uplinks and radios. [Figure 10](#) identifies and describes the LED functions. [Table 3](#) provides additional LED signal information.

Figure 10 Access Point LEDs –Shown on the Bottom of AP 1532E

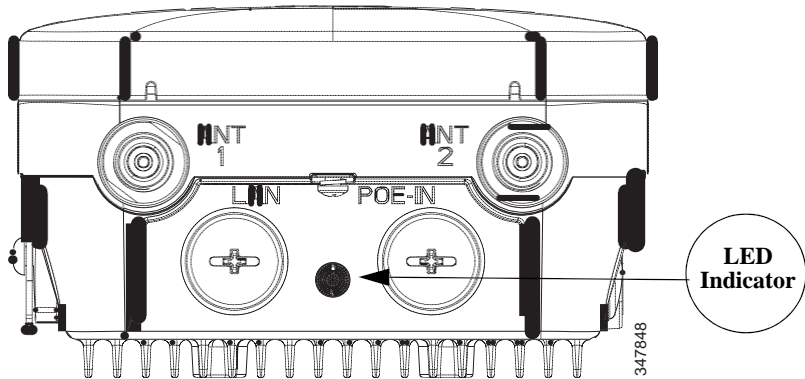

Table 3 Access Point LED Signals

LED Message Type	Color	Meaning
Boot loader status sequence	Blinking Green	<p>Boot loader status sequence:</p> <ul style="list-style-type: none"> • DRAM memory test in progress • DRAM memory test OK • Board initialization in progress • Initializing FLASH file system • FLASH memory test OK • Initializing Ethernet • Ethernet OK • Starting Cisco IOS • Initialization successful

LED Message Type	Color	Meaning
Boot loader warnings	Blinking Amber	Configuration recovery is in progress (the MODE button has been pushed for 2-3 seconds)
	Solid Red	There is an Ethernet failure or an image recovery (the MODE button has been pushed for 20-30 seconds)
	Blinking Green	An image recovery is in progress (the MODE button has been released)
Boot loader errors	Solid Red	There has been a DRAM memory test failure
	Blinking Red and Amber	There has been a FLASH file system failure
	Blinking Red and Off	This sequence may indicate any of the following: <ul style="list-style-type: none"> • Environment variable failure • Bad MAC address • Ethernet failure during image recovery • Boot environment failure • No Cisco image file • Boot failure
Cisco IOS errors	Solid Red	There has been a software failure; a disconnect then reconnect of the unit power may resolve the issue
	Cycling through Red, Green, Amber and Off	This is a general warning of insufficient inline power.
Association status	Chirping (short blips) Green	This status indicates a normal operating condition. The unit is joined to a controller, but no wireless client is associated with it.
	Solid Green	Normal operating condition with at least one wireless client associated with the unit

LED Message Type	Color	Meaning
Operating Status	Blinking Amber	A software upgrade is in progress
	Cycling through Green, Red and Amber	Discovery/join process is in progress
	Rapidly cycling through Red, Green, Amber and Off	This status indicates that the Access Point location command has been invoked.
	Blinking Red	This status indicates that an Ethernet link is not operational
Alignment Mode	Color	Signal Level (dBm)
	Solid Green	> -44
	Fast blinking Green	-47 to -44
	Medium blinking Green	-50 to -47
	Solid Amber	-53 to -50
	Fast blinking Amber	-57 to -53
	Medium blinking Amber	-60 to -57
	Slow blinking Amber	-63 to -60
	Slow blinking Red	-66 to -63
	Medium blinking Red	-69 to -66
	Fast blinking Red	-72 to -69
	Solid Red	-75 to -72
	Off	< -75



Note

Regarding LED status colors, it is expected that there will be small variations in color intensity and hue from unit to unit. This is within the normal range of the LED manufacturer's specifications and is not a defect.

Misconfigured Access Point IP address

IP address misconfiguration can occur when you are re-addressing a segment of your mesh network and you start at the mesh access point connected to the wired network (RAP). To avoid this problem, always start the IP address changes from the farthest access point and work your way back to the root access point. This problem might also happen if you move equipment such as uninstalling a mesh access point and then redeploying with a different IP subnet in another physical location on the mesh network.

Another option to fix this misconfigured IP address is to physically take a controller in Layer 3 mode with a root access point to the location of the misconfigured mesh access point. Set the bridge group name for the root access point to match the misconfigured access point. Add the access point MAC address to the filter list of the controller. When the misconfigured access point appears in the Summary page of the controller, configure the access point with an IP address.

If you are using a static IP address on the access point and plan on redeploying the access point on another subnet, perform a **clear config** command from the controller for that access point while it is joined before you remove it from the network.

Verifying the Controller MAC Filter List

Prior to activating your access point, you must ensure that the access point MAC address has been added to the controller MAC Filter list and that Mac Filter List is enabled. To view the MAC addresses added to the controller MAC filter list and ensure the MAC filter list is enabled, you can use the controller CLI or the controller GUI.

Controller CLI

Use the **show macfilter summary** controller CLI command to view the MAC addresses added to the controller filter list.

Controller GUI

Log into your controller web interface (HTTPS) using a web browser and click **SECURITY > AAA > MAC Filtering** to view the MAC addresses added to the controller filter list. Then click **Wireless > Mesh** to ensure the MAC filter list is enabled.

10 Declarations of Conformity and Regulatory Information

This section provides declarations of conformity and regulatory information for the Cisco 1532 Access Point.

Regulatory Domains

The 1530 series supports the following regulatory domains (shown as “x” in the model numbers):

- -A FCC/North America, including Canada, Mexico, and some South American countries
- -C Malaysia, Egypt
- -D India
- -E ETSI and many European, Middle Eastern, and African countries (EMEA)
- -F Indonesia
- -H China
- -K Korea
- -M Kuwait and Saudi Arabia
- -N Non-FCC, including Hong Kong, Panama, and Mexico
- -Q Japan
- -R Russia
- -S Singapore
- -T Taiwan
- -Z Brazil, Australia and New Zealand

For the latest details and accurate listing of country homologation, refer to “Table 3. 802.11abgn Outdoor Access Points” on the Wireless-LAN-Compliance-Status page at:

http://www.cisco.com/en/US/prod/collateral/wireless/ps5679/ps5861/product_data_sheet0900aecd80537b6a.html#wp9005628

FCC Safety Compliance Statement

The FCC with its action in ET Docket 96-8 has adopted a safety standard for human exposure to radio frequency (RF) electromagnetic energy emitted by FCC certified equipment. When used with approved Cisco Aironet antennas, Cisco Aironet products meet the uncontrolled environmental limits found in OET-65 and ANSI C95.1, 1991. Proper installation of this radio according to the instructions found in this manual will result in user exposure that is substantially below the FCC recommended limits.

Declaration of Conformity for RF Exposure

This access point product has been found to be compliant to the requirements set forth in CFR 47 Section 1.1307 addressing RF Exposure from radio frequency devices as defined in Evaluating Compliance with FCC Guidelines for Human Exposure to Radio Frequency Electromagnetic Fields.

Use is permitted with antenna gain not exceeding 8 dBi in both the 2.4 GHz and 5 GHz band, as described in filing, with a minimum separation distance of 20 cm (8") between the antenna and all persons during normal operation.

Use is permitted with antenna gain not exceeding 13 dBi in the 2.4 GHz and 14 dBi in the 5 GHz band, as described in filing, with a minimum separation distance of 50 cm (20") between the antenna and all persons during normal operation.

Only antennas provided by Cisco for use with the product should be installed. The use of any other antennas may cause damage to the access points or violate regulatory emission limits and will not be supported by Cisco.

Declaration of Conformity with Regard to the EU Directive 1999/5/EC (R&TTE Directive)

This declaration is only valid for configurations (combinations of software, firmware and hardware) provided and/or supported by Cisco Systems. The use of software or firmware not supported/provided by Cisco Systems may result that the equipment is no longer compliant with the regulatory requirements.

Manufacturers Federal Communication Commission Declaration of Conformity Statement



Models

AIR-CAP1532I-A-K9

AIR-CAP1532E-A-K9

Certification Numbers

FCC ID: LDK102090P

FCC ID: LDK102089P

Manufacturer:

Cisco Systems, Inc.
170 West Tasman Drive San
Jose, CA 95134-1706 USA

This device complies with Part 15 rules. Operation is subject to the following two conditions:

1. This device may not cause harmful interference, and
2. This device must accept any interference received, including interference that may cause undesired operation.

This equipment has been tested and found to comply with the limits of a Class B digital device, pursuant to Part 15 of the FCC Rules. These limits are designed to provide reasonable protection against harmful interference when the equipment is operated in a residential environment. This equipment generates, uses, and radiates radio frequency energy, and if not installed and used in accordance with the instructions, may cause harmful interference. However, there is no guarantee that interference will not occur. If this equipment does cause interference to radio or television reception, which can be determined by turning the equipment off and on, the user is encouraged to correct the interference by one of the following measures:

- Reorient or relocate the receiving antenna.
- Increase separation between the equipment and receiver.
- Connect the equipment to an outlet on a circuit different from which the receiver is connected.

- Consult the dealer or an experienced radio/TV technician.

**Caution**

The Part 15 radio device operates on a non-interference basis with other devices operating at this frequency when using the integrated antennas. Any changes or modification to the product (including the use of non-Cisco antennas specified for this model) provided not expressly approved by Cisco could void the user's authority to operate this device.

VCCI Statement for Japan

Warning

This is a Class B product based on the standard of the Voluntary Control Council for Interference from Information Technology Equipment (VCCI). If this is used near a radio or television receiver in a domestic environment, it may cause radio interference. Install and use the equipment according to the instruction manual.

警告

この装置は、クラスB情報技術装置です。この装置は、家庭環境で使用することを目的としていますが、この装置がラジオやテレビジョン受信機に近接して使用されると、受信障害を引き起こすことがあります。

取扱説明書に従って正しい取り扱いをして下さい。

VCCI-B

Guidelines for Operating Cisco Access Points in Japan

This section provides guidelines for avoiding interference when operating Cisco Aironet access points in Japan. These guidelines are provided in both Japanese and English.

Japanese Translation

この機器の使用周波数帯では、電子レンジ等の産業・科学・医療用機器のほか工場の製造ライン等で使用されている移動体識別用の構内無線局（免許を要する無線局）及び特定小電力無線局（免許を要しない無線局）が運用されています。

- 1 この機器を使用する前に、近くで移動体識別用の構内無線局及び特定小電力無線局が運用されていないことを確認して下さい。
- 2 万一、この機器から移動体識別用の構内無線局に対して電波干渉の事例が発生した場合には、速やかに使用周波数を変更するか又は電波の発射を停止した上、下記連絡先にご連絡頂き、混信回避のための処置等(例えば、パーティションの設置など)についてご相談して下さい。
- 3 その他、この機器から移動体識別用の特定小電力無線局に対して電波干渉の事例が発生した場合など何かお困りのことが起きたときは、次の連絡先へお問い合わせ下さい。

連絡先 : 03-6434-6500

208697

English Translation

This equipment operates in the same frequency bandwidth as industrial, scientific, and medical devices such as microwave ovens and mobile object identification (RF-ID) systems (licensed premises radio stations and unlicensed specified low-power radio stations) used in factory production lines.

1. Before using this equipment, make sure that no premises radio stations or specified low-power radio stations of RF-ID are used in the vicinity.
2. If this equipment causes RF interference to a premises radio station of RF-ID, promptly change the frequency or stop using the device; contact the number below and ask for recommendations on avoiding radio interference, such as setting partitions.
3. If this equipment causes RF interference to a specified low-power radio station of RF-ID, contact the number below.

Contact Number: 03-6434-6500

Statement 371—Power Cable and AC Adapter

接続ケーブル、電源コード、ACアダプタ、バッテリーなどの部品は、必ず添付品または指定品をご使用ください。添付品・指定品以外の部品をご使用になると故障や動作不良、火災の原因となります。また、電気用品安全法により、当該法の認定（PSEとコードに表記）でなくUL認定（ULまたはCSAマークがコードに表記）の電源ケーブルは弊社が指定する製品以外の電気機器には使用できないためご注意ください。

English Translation

When installing the product, please use the provided or designated connection cables/power cables/AC adaptors. Using any other cables/adaptors could cause a malfunction or a fire. Electrical Appliance and Material Safety Law prohibits the use of UL-certified cables (that have the “UL” shown on the code) for any other electrical devices than products designated by CISCO. The use of cables that are certified by Electrical Appliance and Material Safety Law (that have “PSE” shown on the code) is not limited to CISCO-designated products.

Industry Canada

Canadian Compliance Statement

AIR-CAP1532I-A-K9

IC: 2461B-102090P

AIR-CAP1532E-A-K9

IC: 2461B-102089P

This Class B Digital apparatus meets all the requirements of the Canadian Interference-Causing Equipment Regulations.

Cet appareil numérique de la classe B respecte les exigences du Règlement sur le matériel brouilleur du Canada.

This device complies with Class B Limits of Industry Canada. Operation is subject to the following two conditions:

1. This device may not cause harmful interference, and
2. This device must accept any interference received, including interference that may cause undesired operation.

Cisco Aironet Access Points are certified to the requirements of RSS-210. The use of this device in a system operating either partially or completely outdoors may require the user to obtain a license for the system according to the Canadian regulations. For further information, contact your local Industry Canada office.

This device has been designed to operate with antennas having a maximum gain of 13 dBi for 2.4 GHz and 14 dBi for 5 GHz. Antennas having a gain greater than 6 dB are strictly prohibited for use with this device. The required antenna impedance is 50 ohms.

To reduce potential radio interference to other users, the antenna type and its gain should be so chosen that the equivalent isotropically radiated power (EIRP) is not more than that permitted for successful communication.

European Community, Switzerland, Norway, Iceland, and Liechtenstein

Models:

AIR-CAP1532I-E-K9

AIR-CAP1532E-E-K9

This device has been designed to operate with antennas having a maximum gain of 13 dBi for 2.4 GHz and 14 dBi for 5 GHz. Antennas having a gain greater than 14 dBi are strictly prohibited for use with this device. The required antenna impedance is 50 ohms.

Declaration of Conformity with regard to the R&TTE Directive 1999/5/EC & Medical Directive 93/42/EEC

български [Bulgarian]:	Tosa oбopyl lsaue OTrosapl ua CbuteCTBemne lf3HCKB3lHill H nplinOlKMHM KJJayJn ua }lHpeKTlisa 1999/5/EC.
Cesky [Czech]:	Toto 7.,afizeni je v souladu se 7.akladnimi po'.adavky a ostatnimi odpovidajicimi ustanovcnimi Smømicc 1999/5/EC.
Dansk [Danish]:	Dette udstyr er i overensstemmelse med de V<£sentlige krav og andre relevante bestemmelser i Direktiv 1999/5/EF.
Deutsch [German]:	Dieses Gerlit entspricht den grundlegenden Anfordenmgen und den weiteren entsprechenden Vorgaben der Richtlinie 1999/5/EU.
Eesti [Estonian]:	See seade vastab direktiivi 1999/5/EO olulistele noueteleja teistele asjakohastele s.iitetele.
English:	This equipment is in compliance with the essential requirements and other relevant provisions of Directive 1999/5/EC.
Español [Spanish]:	Este equipo cumple con los requisitos esenciales asi como con otras disposiciones de la Directiva 1999/5/CE.
Ελληνικά [Greek]:	Aur6 o cl;on),\Oll £1\ rQI cr£ OUIl6piP<l> TJ £ n 0J<HWOEHQhQitl]0'£1KQI <i>aj</i> O'XE"riKt olara £n1Oo•rrial 999/5/EC.
Français [French]:	Cet appareil est conforme aux exigences essentielles et aux autres dispositions pertinentes de la Directive 1999/5/EC.
Íslenska [Icelandic]:	Þetta tæki er samkvæmt grunnkröfum og Mntm viðgagnandi akva:oum Tilskipunar 1999/5/EC.
Italiano [Italian]:	Questo apparato e conforme ai requisiti essenziali ed agli altri principi sanciti dalla Direttiva 1999/5/CE.
Latvian [Latvian]:	Ši iekllrta atbilst OirektTvas 1999/5/EK biitiskajllm prasTbllm un citiem ar to saistilajiem noteikum icm.

Nederlands [Dutch]:	Dit apparaat voldoet aan de essentiële eisen en andere van toepassing zijnde bepalingen van de Richtlijn 1999/5/EC.
Malti [Maltese]:	Dan l-apparat huwa konformi mal-ftiġiet essenzjali u l-provedimenti l-oħra rilevanti tad-Direttiva 1999/5/EC.
Magyar [Hungarian]:	Ez a készülék teljesíti az alapvető követelményeket és más 1999/5/EK irányelvben meghatározott vonatkozó rendelkezéseket.
Norsk [Norwegian]:	Dette utstyret er i samsvar med de grunnleggende krav og andre relevante bestemmelser i EU-direktiv 1999/5/EF.
Polski [Polish]:	Urządzenie jest zgodne z ogólnymi wymaganiami oraz szczególnymi warunkami określonymi Dyrektywą UE: 1999/5/EC.
Português [Portuguese]:	Este equipamento está em conformidade com os requisitos essenciais e outras provisões relevantes da Diretiva 1999/5/EC.
Română [Romanian]:	Acest echipament este în conformitate cu cerințele esențiale și cu alte prevederi relevante ale Directivei 1999/5/EC.
Slovensko [Slovenian]:	Ta naprava je skladna z bistvenimi zahtevami in ostalimi relevantnimi pogoji Direktive 1999/5/EC.
Slovensky [Slovak]:	Toto zariadenie je v zhode so základnými požiadavkami a inými príslušnými nariadeniami direktív: 1999/5/EC.
Suomi [Finnish]:	Tämä laite täyttää direktiivin 1999/5/EY olennaiset vaatimukset ja on siinä asetettujen muiden laitetta koskevien määräysten mukainen.
Svenska [Swedish]:	Denna utrustning är i överensstämmelse med de väsentliga kraven och andra relevanta bestämmelser i Direktiv 1999/5/EC.
Türk [Turkish]:	Bu cihaz 1999/5/EC Direktifi'nin temel gereklerine ve ilgili diğer hükümlerine uygundur.

142730

The following standards were applied:

EMC—EMC-EN 301.489-1 v1.8.1; EN 301.489-17 v2.1.1

Health & Safety—EN60950-1: 2005; EN 50385: 2002

Radio—EN 300 328 v 1.7.1; EN 301.893 v 1.5.1

The conformity assessment procedure referred to in Article 10.4 and Annex III of Directive 1999/5/EC has been followed.

This device also conforms to the EMC requirements of the Medical Devices Directive 93/42/EEC.



Note This equipment is intended to be used in all EU and EFTA countries. Outdoor use may be restricted to certain frequencies and/or may require a license for operation. For more details, contact Cisco Corporate Compliance.

The product carries the CE Mark:



Declaration of Conformity for RF Exposure

United States

This system has been evaluated for RF exposure for Humans in reference to ANSI C 95.1 (American National Standards Institute) limits. The evaluation was based on ANSI C 95.1 and FCC OET Bulletin 65C rev 01.01. The minimum separation distance from the antenna to general bystander is 8" (20 cm) for antenna gains up to 8 dBi and 20" (50 cm) for antenna gains from 8.1 to 14 dBi to maintain compliance.

Canada

This system has been evaluated for RF exposure for Humans in reference to ANSI C 95.1 (American National Standards Institute) limits. The evaluation was based on RSS-102 Rev 2. The minimum separation distance from the antenna to general bystander is 8" (20 cm) for antenna gains up to 8 dBi and 20" (50 cm) for antenna gains from 8.1 to 14 dBi to maintain compliance.

European Union

This system has been evaluated for RF exposure for Humans in reference to the ICNIRP (International Commission on Non-Ionizing Radiation Protection) limits. The evaluation was based on the EN 50385 Product Standard to Demonstrate Compliance of Radio Base stations and Fixed Terminals for Wireless Telecommunications Systems with basic restrictions or reference levels related to Human Exposure to Radio Frequency Electromagnetic Fields from 300 MHz to 40 GHz. The minimum separation distance from the antenna to general bystander is 8" (20 cm) for antenna gains up to 8 dBi and 20" (50 cm) for antenna gains from 8.1 to 14 dBi.

Australia

This system has been evaluated for RF exposure for Humans as referenced in the Australian Radiation Protection standard and has been evaluated to the ICNIRP (International Commission on Non-Ionizing Radiation Protection) limits. The minimum separation distance from the antenna to general bystander is 8" (20 cm) for antenna gains up to 8 dBi and 20" (50 cm) for antenna gains from 8.1 to 14 dBi.

Administrative Rules for Cisco Access Points in Taiwan

This section provides administrative rules for operating Cisco access points in Taiwan. The rules for all access points are provided in both Chinese and English.

Chinese Translation

低功率電波輻射性電機管理辦法

第十二條 經型式認證合格之低功率射頻電機，非經許可，公司、商號或使用者均不得擅自變更頻率、加大功率或變更原設計之特性及功能。

第十四條 低功率射頻電機之使用不得影響飛航安全及干擾合法通信；經發現有干擾現象時，應立即停用，並改善至無干擾時方得繼續使用。

前項合法通信，指依電信法規定作業之無線電信。

低功率射頻電機須忍受合法通信或工業、科學及醫療用電波輻射性電機設備之干擾。

127046

English Translation

Administrative Rules for Low-power Radio-Frequency Devices

Article 12

For those low-power radio-frequency devices that have already received a type-approval, companies, business units or users should not change its frequencies, increase its power or change its original features and functions.

Article 14

The operation of the low-power radio-frequency devices is subject to the conditions that no harmful interference is caused to aviation safety and authorized radio station; and if interference is caused, the user must stop operating the device immediately and can't re-operate it until the harmful interference is clear.

The authorized radio station means a radio-communication service operating in accordance with the Communication Act.

The operation of the low-power radio-frequency devices is subject to the interference caused by the operation of an authorized radio station, by another intentional or unintentional radiator, by industrial, scientific and medical (ISM) equipment, or by an incidental radiator.

Chinese Translation

低功率射頻電機技術規範

4.7 無線資訊傳輸設備

4.7.6 無線資訊傳輸設備須忍受合法通信之干擾且不得干擾合法通信；如造成干擾，應立即停用，俟無干擾之虞，始得繼續使用。

4.7.7 無線資訊傳輸設備的製造廠商應確保頻率穩定性，如依製造廠商使用手冊上所述正常操作，發射的信號應維持於操作頻帶中。

200139

English Translation

Low-power Radio-frequency Devices Technical Specifications

- 4.7 Unlicensed National Information Infrastructure
- 4.7.6 The U-NII devices shall accept any interference from legal communications and shall not interfere the legal communications. If interference is caused, the user must stop operating the device immediately and can't re-operate it until the harmful interference is clear.
- 4.7.7 Manufacturers of U-NII devices are responsible for ensuring frequency stability such that an emission is maintained within the band of operation under all conditions of normal operation as specified in the user manual.

Operation of Cisco Aironet Access Points in Brazil

This section contains special information for operation of Cisco Aironet access points in Brazil.

Access Point Models

AIR-CAP1532I-Z-K9

AIR-CAP1532E-Z-K9

Portuguese Translation

Este equipamento opera em caráter secundário, isto é, não tem direito a proteção contra interferência prejudicial, mesmo de estações do mesmo tipo, e não pode causar interferência a sistemas operando em caráter primário.

English Translation

This equipment operates on a secondary basis and consequently must accept harmful interference, including interference from stations of the same kind. This equipment may not cause harmful interference to systems operating on a primary basis.

Declaration of Conformity Statements

All the Declaration of Conformity statements related to this product can be found at the following location: <http://www.cisconfax.com>.

11 Warranty

Cisco Aironet 1530 Series Outdoor Mesh Access Points come with a one-year warranty. For more details, visit <http://www.cisco.com/go/warranty>, and look up the 1530 series access points in the Warranty Finder tool.