

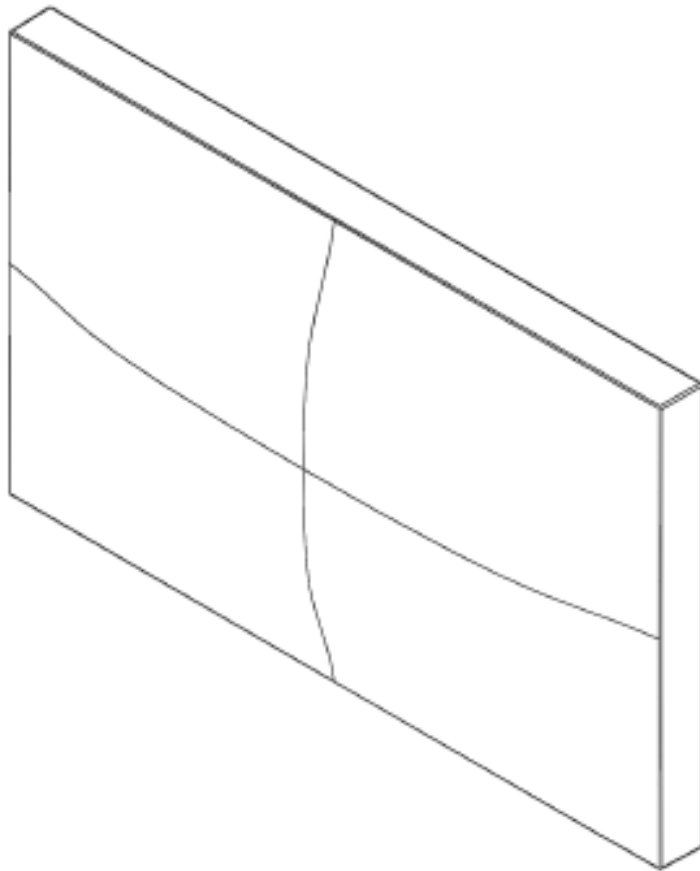

Meraki



Meraki MR34

Hardware Installation Guide

Trademarks

Meraki, Meraki MR34, Meraki Cloud Controller, and Meraki Mesh are trademarks of Cisco Systems, Inc. Other brand and product names are registered trademarks or trademarks of their respective holders.

Statement of Conditions

In the interest of improving internal design, operational function, and/or reliability, Cisco Systems reserves the right to make changes to the products described in this document without notice. Cisco Systems does not assume any liability that may occur due to the use or application of the product(s) or circuit layout(s) described herein.

Warranty

Meraki, Inc. provides a lifetime warranty on this product. Warranty details may be found at www.meraki.com/legal.

Table of Contents

1	Scope of Document and Related Publications	4
2	MR34 Overview	5
	2.1 Package Contents	5
	2.2 Understanding the MR34	5
	2.3 Security Features	7
	2.4 Ethernet Ports	7
	2.5 Power Source Options	7
	2.6 Factory Reset Button	7
	2.7 LED Indicators and Run Dark Mode	7
	2.8 UL 2043 Plenum rating	8
3	Pre-Install Preparation	8
	3.1 Configure Your Network in Dashboard	8
	3.2 Check and Upgrade Firmware	8
	3.3 Check and Configure Firewall Settings	8
	3.4 Assigning IP Addresses to MR34s	9
	3.4.1 Dynamic Assignment	9
	3.4.2 Static Assignment	9
	3.4.3 Static IP Assignment via DHCP Reservations	9
	3.5 Collect Tools	10
	3.6 Collect Additional Hardware for Installation	10
4	Installation Instructions	11
	4.1 Choose Your Mounting Location	11
	4.2 Install the MR34	11
	4.2.1 Attach the Mount Plate	11
	4.2.1.1 Wall or Solid Ceiling Mount Using Mount Plate	13
	4.2.1.2 Drop Ceiling Mount Using Mount Plate	14
	4.2.1.3 Electrical Junction Box Mount Using Mount Plate	18
	4.2.1.4 Plenum Mount (Above Drop Ceiling)	19
	4.2.2 Power the MR34	20
	4.2.2.1 Powering the MR34 with Meraki AC Adapter	21
	4.2.2.2 Powering the MR34 with Meraki 802.3af Power over Ethernet Injector	21
	4.2.2.3 Powering the MR34 with an 802.3af Power over Ethernet Switch	22
	4.2.3 Mount the MR34	22
	4.2.3.1 Assemble Security Hasp to the MR34	22
	4.2.3.2 Assemble MR34 to the Mount Plate	23
	4.2.3.3 Desk or Shelf Mount	25
	4.3 Secure the MR34	26
	4.3.1 Security Screw	26
	4.3.2 Kensington Lock	26
	4.4 Verify Device Functionality and Test Network Coverage	27
5	Troubleshooting	27

1 Scope of Document and Related Publications

The MR34 Hardware Installation Guide describes the installation procedure for the MR34 access point.

Additional reference documents are available online at www.meraki.com/library/product.

2 MR34 Overview

The Meraki MR34 is an enterprise-class, dual-concurrent 3x3 MIMO 802.11n access point designed for high-density deployments in offices, schools, hospitals and hotels. When connected to the Meraki Cloud Controller, the MR34 enables the creation of ultra-high speed, reliable indoor wireless networks quickly, easily and cost-effectively.

2.1 Package Contents

The MR34 package contains the following:

MR34 access point

Mounting plate

Drop ceiling mounting kit

Wall screws

Security screws

Mounting Template

2.2 Understanding the MR34

Your Meraki MR34 has the following features:

Kensington lock
hard point

Mount plate attachment
slots (2x)

Cable access bay

Desk mount feet (4x)

MR34 cable access bay

Factory Reset Button

Ethernet 0 port (10/100/1000)

AC Adapter plug

Your MR34 mount plate has the following features:

Access point
mounting posts (2x)

Various mounting holes

2.3 Security Features

The MR34 features multiple options for physically securing the access point after installation:

1. Security screw – The accessory kit includes screws that can be used to secure the access point to the mount plate. Engaging the security screw prevents accidental dislodging and theft.
2. Kensington lock – The access point contains a hard point that allows it to be secured to any nearby permanent structure using a standard Kensington lock.

2.4 Ethernet Ports

Both MR34 and MR34 feature a Gigabit Ethernet RJ45 port that accepts 802.3af power (labeled “Eth0, PoE”). This port should be used for uplink to your WAN connection.

2.5 Power Source Options

The MR34 access point can be powered using either the Meraki AC Adapter or 802.3af PoE Injector (both sold separately) or a third-party 802.3af PoE switch.

2.6 Factory Reset Button

If the button is pressed and held for at least five seconds and then released, the MR34 will reboot and be restored to its original factory settings by deleting all configuration information stored on the unit.

2.8 UL 2043 Plenum rating

The MR34 meets the UL 2043 plenum-rating standard. This certifies that the MR34 has adequate fire resistance and low smoke-emission characteristics to be mounted and operated in a building's environmental air spaces, such as above suspended ceilings in an office environment.

3 Pre-Install Preparation

You should complete the following steps before going on-site to perform an installation.

3.1 Configure Your Network in Dashboard

The following is a brief overview only of the steps required to add an MR34 to your network. For detailed instructions about creating, configuring and managing Meraki wireless networks, refer to the Meraki Cloud Controller Manual (meraki.com/library/product).

1. Login to <http://dashboard.meraki.com>. If this is your first time, create a new account.
2. Find the network to which you plan to add your APs or create a new network.
3. Add your APs to your network. You will need your Meraki order number (found on your invoice if you ordered directly from Meraki) or the serial number of each AP, which looks like Qxxx-xxxx-xxxx, and is found on the bottom of the unit. You will also need your Enterprise Cloud Controller license key, which you should have received via email from shipping@meraki.com.
4. Go to the map / floor plan view and place each AP on the map by clicking and dragging it to the location where you plan to mount it.

3.2 Check and Upgrade Firmware

To ensure your MR34 performs optimally immediately following installation, Meraki recommends that you facilitate a firmware upgrade prior to mounting your MR34.

1. Attach your MR34 to power and a wired Internet connection. See p. 19 of this Hardware Installation Guide for details.
 2. The MR34 will turn on and the Power LED will glow solid orange. If the unit does not require a firmware upgrade, the Power LED will turn white within thirty seconds.
- * If the unit requires an upgrade, the Power LED will begin blinking orange until the upgrade is complete, at which point the Power LED will turn solid white. You should allow about an hour for the firmware upgrade to complete, depending on the speed of your internet connection.

3.3 Check and Configure Firewall Settings

If a firewall is in place, it must allow outgoing connections on particular ports to particular IP addresses. The most current list of outbound ports and IP addresses can be found here:

<http://tinyurl.com/y79une3>

3.4 Assigning IP Addresses to MR34s

All gateway MR34s (MR34s with Ethernet connections to the LAN) must be assigned routable IP addresses. These IP addresses can be dynamically assigned via DHCP or statically assigned.

3.4.1 Dynamic Assignment

When using DHCP, the DHCP server should be configured to assign a static IP address for each MAC address belonging to a Meraki AP. Other features of the wireless network such as 802.1x authentication, may rely on the property that the APs have static IP addresses.

3.4.2 Static Assignment

Static IPs are assigned using the local web server on each AP. The following procedure describes how to set the static IP:

1. Using a client machine (e.g. a laptop), connect to the AP either wirelessly (by associating to any SSID broadcast by the AP) or over a wired connection.

If using a wired connection, connect the client machine to the MR34 either through a PoE switch or a Meraki PoE Injector. If using a PoE switch, plug an Ethernet cable into the MR34's Ethernet jack, and the other end into a PoE switch. Then connect the client machine over Ethernet cable to the PoE switch. If using a Meraki PoE Injector, connect the MR34 to the "PoE" port of the Injector, and the client machine to the "LAN" port.

2. Using a web browser on the client machine, access the AP's built-in web server by browsing to <http://my.meraki.com>. Alternatively, browse to <http://10.128.128.128>.
3. Click on the "Static IP Configuration" tab. Log in. The default user name is "admin". The default password is the AP's serial number, with hyphens included
4. Configure the static IP address, net mask, gateway IP address and DNS servers that this AP will use on its wired connection.
5. If necessary, reconnect the AP to the LAN.

3.4.3 Static IP via DHCP Reservations

Instead of associating to each Meraki AP individually to configure static IP addresses, an administrator can assign static IP addresses on the upstream DHCP server. Through "DHCP reservations", IP addresses are "reserved" for the MAC addresses of the Meraki APs. Please consult the documentation for the DHCP server to configure DHCP reservations.

3.5 Collect Tools

You will need the following tools to perform an installation:



Phillips
screwdriver



Hammer

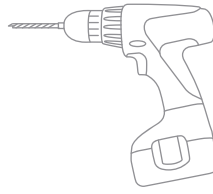

Drill with 1/4"
(6.3mm) bits

3.6 Collect Additional Hardware for Installation



802.3af PoE power source (either PoE
switch or Meraki 802.3af PoE Injector)

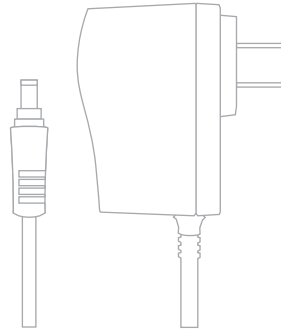

AC Adapter

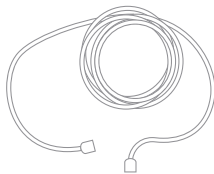

Network cables with RJ45 connectors long
enough for your particular mounting location

4 Installation Instructions

4.1 Choose Your Mounting Location

A good mounting location is important to getting the best performance out of your MR34 access point. Keep the following in mind:

1. The device should have unobstructed line of sight to most coverage areas. For example, if installing in an office filled with workspaces divided by mid-height cubicle walls, installing on the ceiling or high on a wall would be ideal.
2. Power over Ethernet supports a maximum cable length of 300 ft (100 m).
3. If being used in a mesh deployment, the MR34 should have line of sight to at least two other Meraki devices. For more detailed instructions regarding access point location selection, reference the Meraki Network Design Guide (meraki.com/library/product).

4.2 Install the MR34

For most mounting scenarios, the MR34 mount plate provides a quick, simple, and flexible means of mounting your device. The installation should be done in two steps. First, install the mount plate to your selected location. Then, attach the MR34 to the mount plate.

4.2.1 Attach the Mount Plate

The MR34 mount plate can be used to install your access point in a wide range of scenarios: wall or solid ceiling, below a drop ceiling, on various electrical junction boxes, or above a drop ceiling (in the plenum).

The mount plate contains a variety of hole patterns that are customized for each installation scenario. The mounting template (included in box with mount plate) should be used to drill holes for wall mounts and also to identify the correct hole patterns in the mount plate that should be used for each type of mount.

The following images also show the hole patterns that should be used for each type of mount:

4.2.1.1 Wall or Solid Ceiling Mount Using Mount Plate

Using included screws, attach the mount plate to your mounting wall or ceiling.

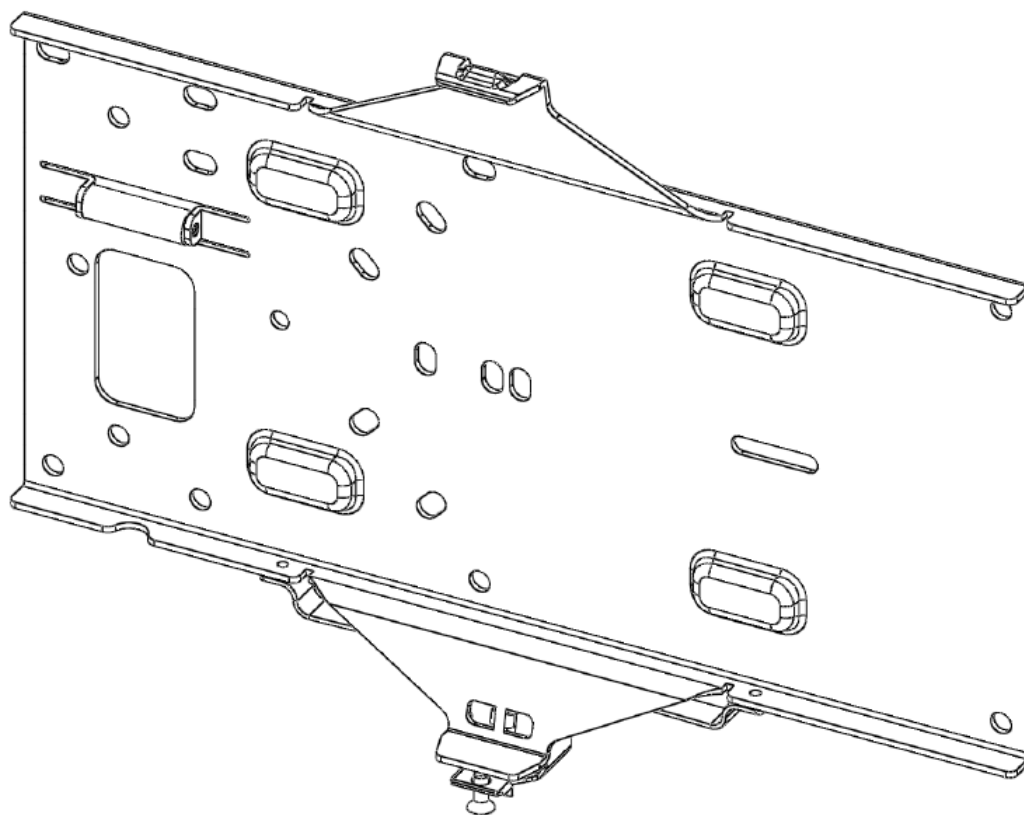

It is recommended that the MR34 be mounted to a wall or solid ceiling using the mount plate for physical security reasons.

! If mounting your MR34 to a wall, skip to “Power the MR34” on P. 20

4.2.1.2 Drop Ceiling Mount Using Mount Plate

To mount your MR34 on a drop ceiling T-rail, use the included drop ceiling mounting accessory kit. The accessory kit can be used to mount to most 9/16", 15/16" or 1 1/2" T-rails.

The kit contains:

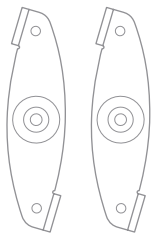

Dropped ceiling mounting clips with set screws



6-32x4 mm screws



6-32x7 mm screws
Only used for recessed rail mount (uncommon)



2 rubber spacers
Only used for recessed rail mount (uncommon)

1. Attach the T-rail clips to the T-rail by rotating them and snapping them into place as shown. The black foam pads should be compressed slightly after installation.

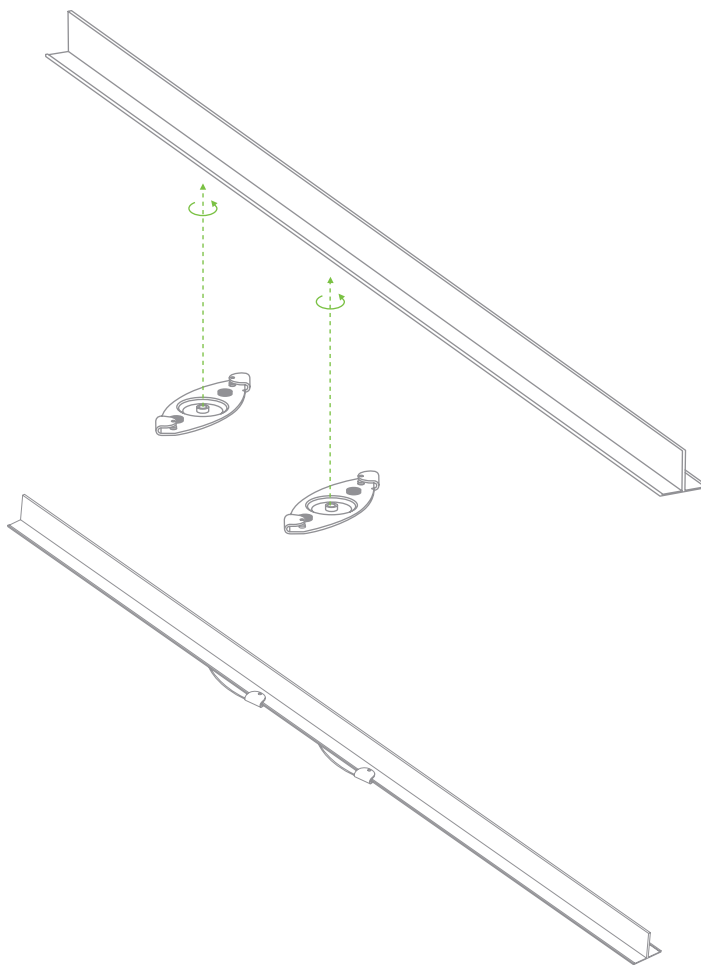

2. Using the dashed lines on the mount plate template as a guide, set the proper spacing of the T-rail clips on the T-rail

3. Tighten the set screws on the T-rail clips to secure the clips using a 5/64”(2 mm) hex key.

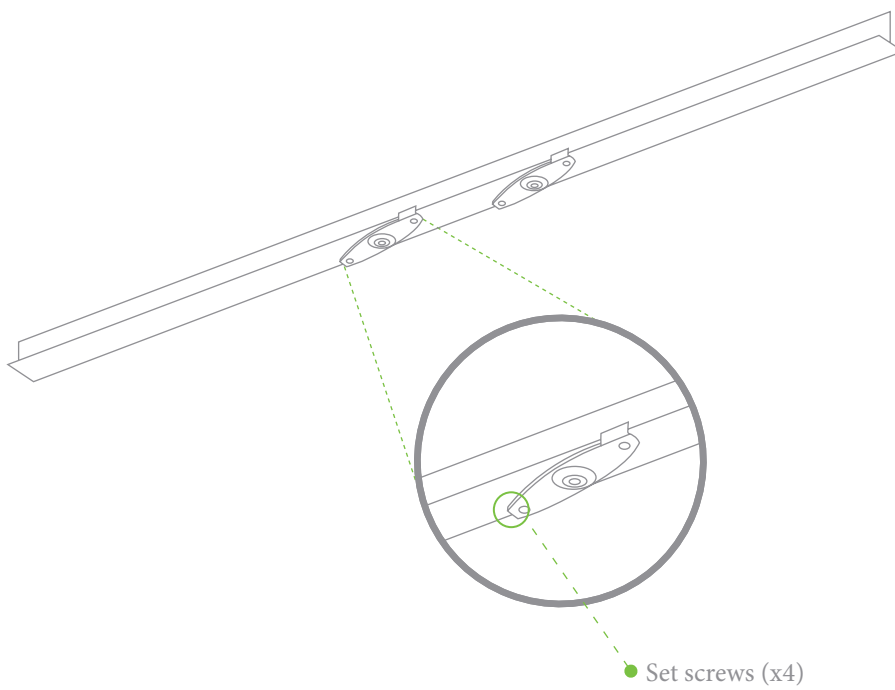

4. Attach the mount plate to the T-rail clips using the mount plate holes (marked with a "T").



To select the correct set of mounting hardware to use, first determine whether you are mounting to a "flush" or "recessed" rail. (See below images for clarification)

Flush T-rail

Recessed T-rail

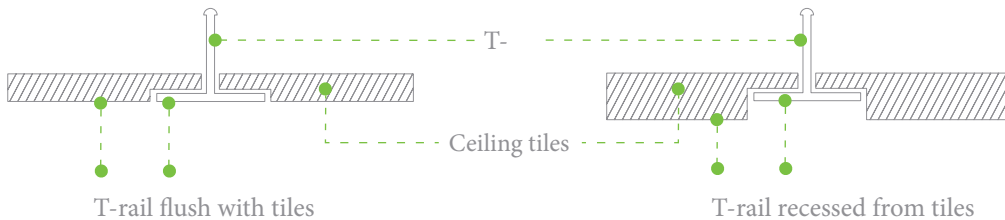

4.2.1.3 Electrical Junction Box Mount Using Mount Plate

The MR34 can be mounted to a 4" square cable junction box, a 3.5 or 4" round cable junction box, or various U.S. and European outlet boxes (mounting screws are not included).

Using appropriate mounting hardware for your specific type of junction box, attach the mount plate to the junction box.

4.2.1.4 Plenum Mount (Above Drop Ceiling)

The MR34 can be mounted to the T-bar grid above the tiles of a drop ceiling using a 3rd party T-bar box hanger (not included). The Erico Caddy 512A is recommended and is used in installation instruction illustrations.

Note: a UL2043-rated Ethernet cable should be used for a plenum installation.

1. Adjust the height of the T-bar box hanger crossbar to make sure there is adequate clearance between the access point and the top of the ceiling tiles. Tighten the height adjusting screws.
2. Attach the bracket mounting clip (included with T-bar box hanger) to the center of the T-bar box hanger crossbar.
3. Attach the MR34 mount plate to the access point mounting bracket using a 6-32 screw, washer, and nut (not included with T-bar box hanger) and the Above Drop Ceiling (Box Hanger) hole in the mount plate (reference Mounting Template).

4. Securely attach the clips on either side of the T-bar box hanger to the suspended ceiling grid T-rails.
5. Connect a grounding wire (not included with T-bar box hanger) to the grounding hole in the bracket mounting clip and to metal building structure. A grounding wire is required to comply with the U.S. National Electric Safety Code.

4.2.2 Power the MR34

If mounting to an electrical junction box, feed the Ethernet cable through the cable access hole in the Mount Plate:

If mounting to a wall or ceiling, the Ethernet cable will feed through the cable slot on bottom of the MR34.

4.2.2.1 Powering the MR34 with the Meraki AC Adapter (sold separately)

1. Plug the power cord into the MR34 and the other end into a wall outlet.
2. Plug an Ethernet cable that is connected to an active Ethernet connection into the Eth0 port on the MR34.

4.2.2.2 Powering the MR34 with the Meraki 802.3af Power over Ethernet Injector (sold separately)

1. Plug the power cord into the PoE Injector and the other end into wall power.
2. Plug an Ethernet cable that is connected to an active Ethernet connection into the “IN” port on the injector.
3. Route Ethernet cable from the “OUT” port on the injector to the Eth0 port in the cable bay of the MR34.

4.2.2.3 Powering the MR34 with an 802.3af Power over Ethernet Switch

Route Ethernet cable from a port on an active 802.3af PoE switch to the Eth0 port in the bay of the MR34.

! The MR34 is Gigabit Ethernet-capable. To maximize device performance, a Gigabit-capable switch should be used.

4.2.3 Mount the MR34

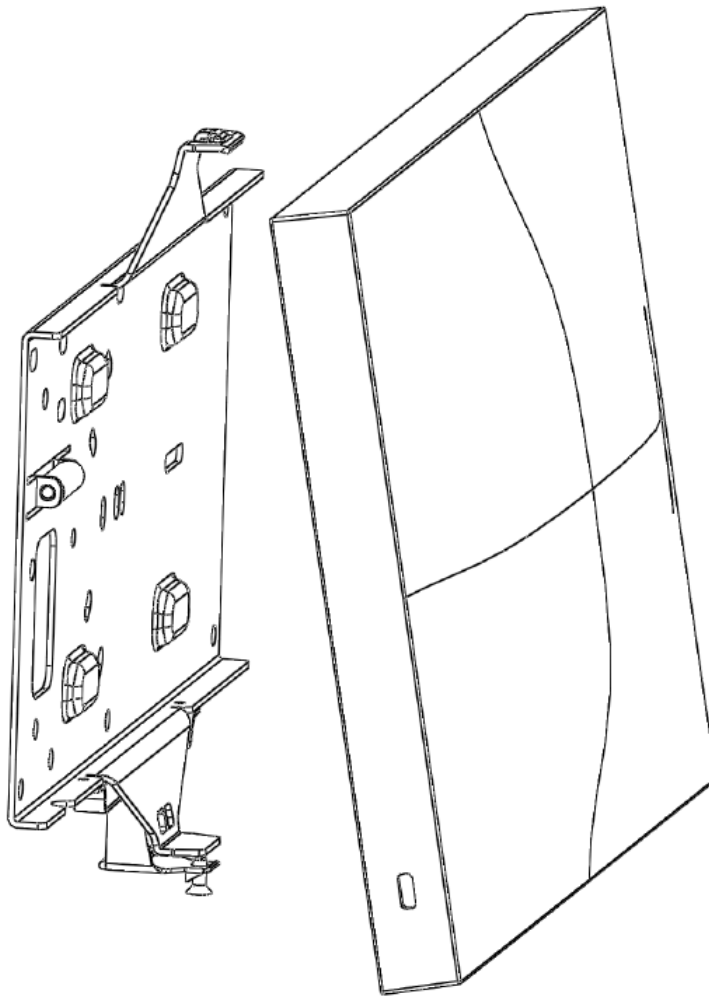

4.2.3.2 Assemble MR34 to the Mount Plate

(This section applies to wall and/or solid ceiling, drop ceiling or electrical junction box mount where you have already installed the mount plate.)

Insert the top latch on the mount plate into the top mount plate attachment slots on the back of the device. Rotate the bottom of the unit into the bottom mount plate attachment slot. The unit will click into place.

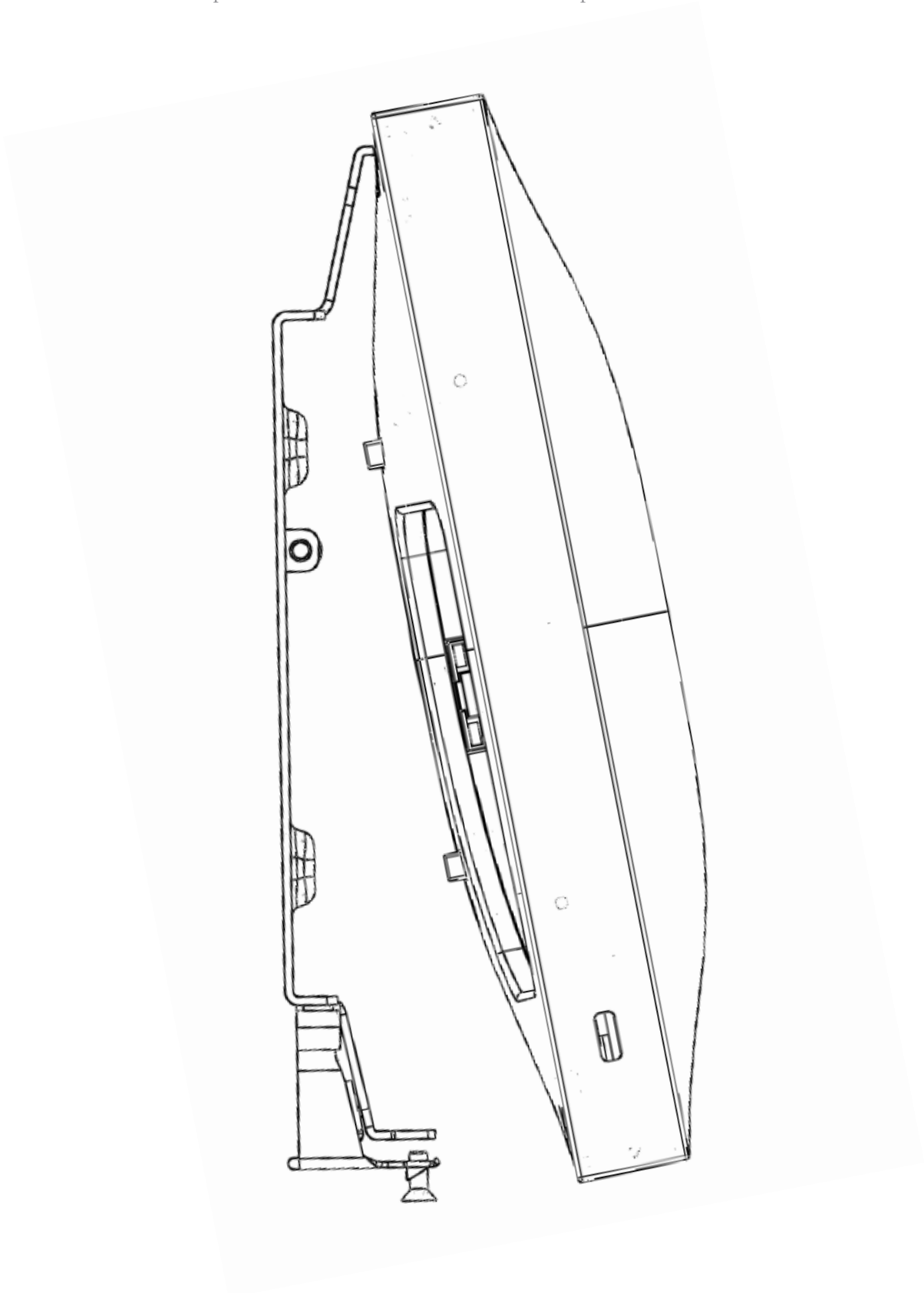

4.2.3.3 Desk or Shelf Mount

The MR34 can be placed on a desk or shelf resting on the non-scratch rubber feet. The mount plate is not necessary for a desk or shelf mounting.

4.3 Secure the MR34

Depending on your mounting environment, you may want to secure the MR34 to its mount location. Your MR34 can be secured in several ways. If the MR34 has been installed using the mount plate, it can be secured via security screw (Torx and phillips head security screws are included; choose one), and/or Kensington lock. If the mount plate was not used, the MR34 can still be secured using a Kensington lock.

4.3.1 Security Screw

Install the security screw in the lower mount plate tab.

4.3.2 Kensington Lock

Attach a Kensington lock cable to the access point at the hard point on the side of the device. Attach the other end of the cable to a secure location, such as a pipe or building fixture.

4.4 Verify Device Functionality and Test Network Coverage

1. Check LEDs

The LED should be solid white. If it is flashing orange, the firmware is automatically upgrading and the LED should turn green when the upgrade is completed (normally in under thirty minutes).

Note: Your MR34 must have an active route to the Internet to check and upgrade its firmware.

2. Verify access point connectivity

Use any 802.11 client device to connect to the MR34 and verify proper connectivity using the client's web browser.

3. Check network coverage

Confirm that you have good signal strength throughout your coverage area. You can use the signal strength meter on a laptop, smart phone, or other wireless device.

5 Troubleshooting

Reference the Meraki knowledge base at http://meraki.com/support/knowledge_base for additional information and troubleshooting tips.

Copyright

© 2013 Cisco Systems, Inc. All rights reserved.

Trademarks

Cisco Systems® is a registered trademark of Cisco Systems, Inc.

