



# Cisco Connected Grid 3G Module Installation and Configuration Guide

---

**First Published: January, 2012**

**Part Number: OL-25991-01**

This document provides an overview of hardware and configuration information for the following single-wide grid router WAN interface card modules:

- Cisco Connected Grid Module—3G EVDO Rev A/0/1xRTT (CDMA version)
- Cisco Connected Grid Module—3G HSPA+/UMTS/GSM/GPRS/EDGE (GSM version)

These 3rd Generation technology modules are supported on Cisco 1240 Connected Grid Router.

This document contains the following topics:

- [Kit Contents, page 2](#)
- [Features, page 4](#)
- [Hardware Overview, page 5](#)
- [Installing and Removing the SIM Card \(GSM Module\), page 17](#)
- [Installing and Removing the 3G Module, page 18](#)
- [Regulatory and Compliance Information, page 21](#)
- [Software Overview, page 21](#)
- [Configuring the Module, page 24](#)
- [Configuration Example, page 33](#)
- [Debug Commands, page 38](#)
- [Additional References, page 36](#)
- [Technical Assistance, page 37](#)
- [Troubleshooting and Diagnostics, page 38](#)



**Warning**

---

**Only trained and qualified personnel should be allowed to install, replace, or service this equipment.**  
Statement 1030

---



---

**Americas Headquarters:**  
**Cisco Systems, Inc., 170 West Tasman Drive, San Jose, CA 95134-1706 USA**



**Note** The Cisco Connected Grid 3G Module is installed in the router at the factory. Only Cisco Systems or Itron, Inc. technicians may install, uninstall, or configure Connected Grid Modules.

**Figure 1** Cisco Connected Grid 2G/3G Wireless Connected Grid Module

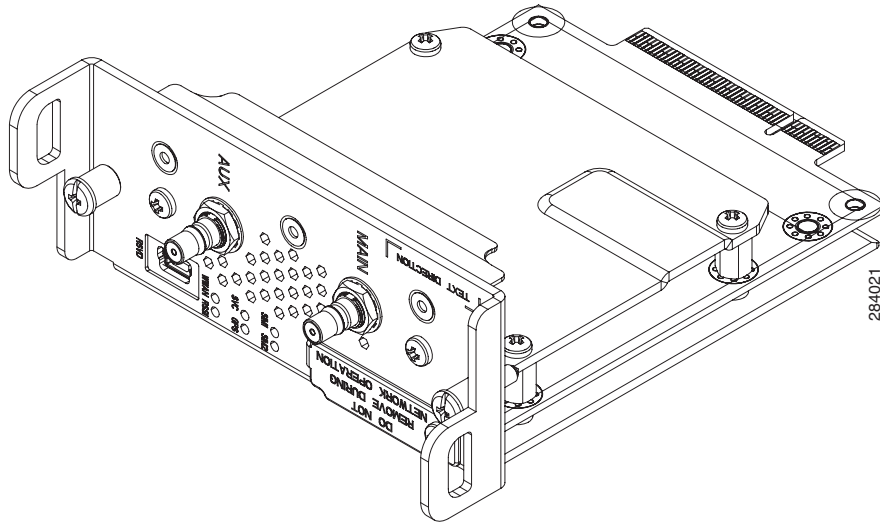

## Kit Contents

Your 3G module kit contains the GSM or CDMA module. Parts can be ordered by referencing the following information shown in [Table 1](#).

**Table 1** Kit Contents for the 3G Module

Cisco Part Number	Mode	Description	Frequency Band
CGM-3G-EVDO-V	CDMA/EVDO	Connected Grid Module - 3G Verizon EVDO Rev A/0/1xRTT	<ul style="list-style-type: none"> <li>800 MHz: North American cellular band</li> <li>1900 MHz: North American PCS band</li> </ul>
CGM-3G-EVDO-S	CDMA/EVDO	Connected Grid Module - 3G Sprint EVDO Rev A/0/1xRTT	<ul style="list-style-type: none"> <li>800 MHz: North American cellular band</li> <li>1900 MHz: North American PCS band</li> </ul>

**Table 1**      **Kit Contents for the 3G Module**

<b>Cisco Part Number</b>	<b>Mode</b>	<b>Description</b>	<b>Frequency Band</b>
CGM-3G-HSPA-A	GSM/HSPA+	Connected Grid Module - 3G AT&T HSPA+/UMTS/GSM/GPRS/EDGE	<ul style="list-style-type: none"> <li>• GSM: 850, 900, 1900 MHz.</li> <li>• WCDMA/UMTS/HSPA+: 850, 900, 1800, 1900, 2100 MHz.</li> </ul>
CGM-3G-HSPA-G	GSM/HSPA+	Connected Grid Module - 3G (Global) HSPA+/UMTS/GSM/GPRS/EDGE	<ul style="list-style-type: none"> <li>• GSM: 850, 900, 1900 MHz.</li> <li>• WCDMA/UMTS/HSPA+: 850, 900, 1800, 1900, 2100 MHz.</li> </ul>

For system requirements, important notes, limitations, open and resolved bugs, and last-minute documentation updates, see the Release Notes on Cisco.com. For translations of the warnings that appear in this document, see the *Regulatory Compliance and Safety Information* document for your router on Cisco.com.

When using the online publications, see the documents that match the Cisco system software version running on the 2G/3G wireless module.

# Features

Cisco Connected Grid 3G GSM Modules offer the following features:

**Table 2 Feature Information for 3G module**

3G GSM Module	3G CDMA Module
<ul style="list-style-type: none"> <li>• MC8705 PCI Express Mini Card wireless data modem:                             <ul style="list-style-type: none"> <li>– GSM data connectivity</li> <li>– GSM SIM-card interface</li> <li>– USB 2.0 high-speed (480 Mbps) interface for data and management traffic</li> <li>– Supports 850 MHz, 900 MHz, 1800 MHz, and 1900 MHz frequencies</li> <li>– PCI Express chip-set interface</li> <li>– Input/output hub component for embedded applications</li> </ul> </li> </ul>	<ul style="list-style-type: none"> <li>• MC5728V PCI Express Mini Card wireless data modem:                             <ul style="list-style-type: none"> <li>– CDMA data connectivity</li> <li>– 1xEVDO data connectivity (full-mini and half-mini)</li> <li>– USB 2.0 high-speed (480 Mbps) interface for data and management traffic</li> <li>– Supports 800 MHz, 850 MHz, 900 MHz, 1900 MHz, and 2100 MHz frequencies</li> <li>– PCI Express chip-set interface</li> <li>– Input/output hub component for embedded applications</li> </ul> </li> </ul>
<ul style="list-style-type: none"> <li>• Support for the following technologies:                             <ul style="list-style-type: none"> <li>– High Speed Packet Access (HSPA and HSPA+)</li> <li>– High-speed Downlink Packet Access (HSDPA)</li> <li>– High-speed Uplink Packet Access (HSUPA)</li> <li>– Universal Mobile Telecommunication System (UMTS)</li> <li>– Enhanced Data-Rates for GSM Evolution (EDGE)</li> <li>– General Packet Radio Service (GPRS)</li> </ul> </li> </ul>	<ul style="list-style-type: none"> <li>• Support for the following technologies:                             <ul style="list-style-type: none"> <li>– EVDO Rev. A</li> <li>– EVDO Rel. 0</li> <li>– 1xRTT</li> </ul> </li> </ul>

The Cisco Connected Grid 3G GSM and CDMA modules share the following key features:

- Supported on the Cisco 1240 Connected Grid Router and the Cisco 1120 Connected Grid Router
- Supports Cisco system software
- Provides the primary cellular WAN connection for critical data applications in supporting the Connected-Grid Router
- WAN connectivity as a backup data link for critical data applications
- USB interface—Data, control, and diagnostics channels; control, bulk, and interrupt transfers; low (1.1 Mbps), full (12 Mbps), and high (480 Mbps) speeds
- SIM plug-in SIM card—USB, ISO 7816 compliant, (U)SAT commands, USIM, 3G phone book, flash memory 8/6/128-1024 MB

3G module provides the following functionality:

- Broadband WAN connectivity using high-speed cellular data technology
- Automatic best-network selection
- Always-on capability
- Multiple antenna and cable options:
  - Diversity antenna
  - Indoor and outdoor external antennas
  - Radio Frequency Ultra-Low Loss (RF-ULL) cable
- Dynamic IP addressing
- Cellular modem upgrade over wireless link
- Modem management—Enables you to access modem software and hardware information, radio and network status, and data profile information by using Cisco commands.
- Auto-detect—3G WAN for fixed and modular routers automatically detects and uses the best available service.
- Profile Configuration—Enables you to configure the Access-Point Name (APN) profile.
- Firmware upgrade—Enables you to upgrade the firmware on the modem by using Cisco commands.
- 3G wireless WAN for fixed and modular routers support on Cisco Connected Grid Router 1000 Series platforms.

## Hardware Overview

The 3G modules are wireless modules with a mini-card cellular modem (PCI-e mini-card form factor). The 3G module comes in two types of technologies: GSM and CDMA. This document describes the CDMA module and the GSM model.

The module connects to the host router board of the Cisco 1210 Connected Grid Router or Cisco 1240 Connected Grid Router through a PCI-E edge connector with a Cisco-proprietary interface.

The mini-card series modems support a PCI-E connection, as well as USB 2.0. The host router communicates to the 3G module and manages traffic via USB.

This section covers the following topics:

- [Front Panel, page 6](#)
- [Ports and LEDs, page 7](#)
- [Supported Cisco Antennas, page 10](#)
- [Supported Cisco Cables, page 11](#)
- [3G Module Models, page 11](#)
- [Interfaces, page 11](#)
- [Radio Frequency Interface, page 12](#)
- [Environmental Specifications, page 12](#)
- [Power Specifications, page 12](#)
- [Modem, page 13](#)
- [GSM Module SIM Interface, page 14](#)

- Voltage Monitoring State Machine, page 15
- Temperature Monitoring State Machine, page 15
- Data Rates, page 15
- USB Interface, page 15
- Memory Specifications, page 16
- Module Power States, page 16

## Front Panel

Figure 2 shows the front panel components of the 3G module.

**Figure 2 Front Panel of the 3G module**

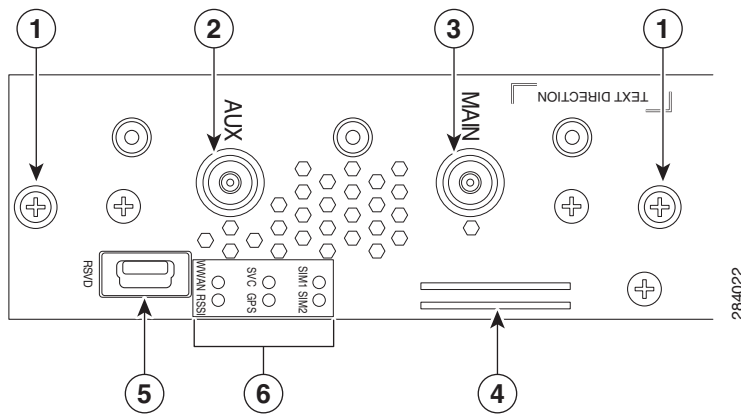

<b>1</b>	Captive screws (2)	<b>2</b>	Auxiliary port <sup>1</sup>
<b>3</b>	Main port <sup>2</sup>	<b>4</b>	SIM card slots
<b>5</b>	RSVD <sup>3</sup>	<b>6</b>	LEDs <sup>4</sup>

1. QMA connector for antenna is used for optional RX diversity or GPS antenna. Since the module GPS is not used (GPS of host router is used), connector must be terminated with a 50-Ohm terminator.
2. QMA connector for antenna—transmits and receives RF.
3. Mini-USB port (can be diagnostic port).
4. WWAN, RSSI, SVC1, SVC2, SIM1, and SIM2.

## Ports and LEDs

Figure 3 shows the LEDs of the Cisco Connected Grid 3G Module.

**Figure 3** 2G/3G Connected Grid Module LEDs

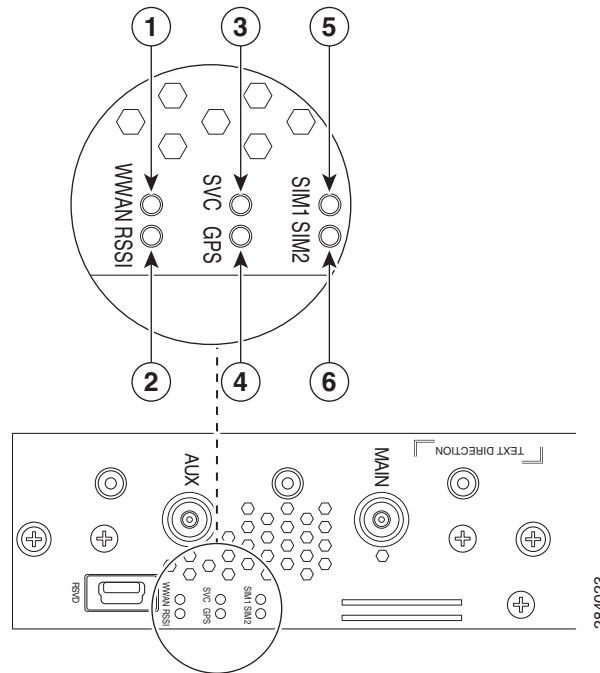

<b>1</b>	WWAN LED	<b>2</b>	RSSI LED
<b>3</b>	SVC LED	<b>4</b>	GPS LED (not used)
<b>5</b>	SIM1 LED (for GSM version)	<b>6</b>	SIM2 LED (for GSM version)

Table 3 lists the ports and the LED indicators and describes their behavior. The LEDs provide a visual indication of the available services.

**Table 3** LED Definitions

Port or LED Name	Color	Description
WWAN	Green	<p>Indicates the modem status. Driven by the modem, not under software control except for diagnostic purposes. Functionality may be changed by configuring modem.</p> <ul style="list-style-type: none"> <li>• <b>Off:</b> Module not powered</li> <li>• <b>On:</b> Module is powered on and connected but not transmitting or receiving</li> <li>• <b>Slow blink:</b> Module is powered on and searching for connection</li> <li>• <b>Fast blink:</b> Module is transmitting or receiving.</li> </ul> <p>For information on modem settings, see <a href="#">Modem, page 13</a>.</p>
RSSI	Bi-color, green/amber	<p>Indicates the level of signal strength received by the software.</p> <p>LEDs can be lit as follows:</p> <ul style="list-style-type: none"> <li>• <b>Off:</b> RSSI <math>\leq -110</math></li> <li>• <b>Solid amber:</b> <math>-100 &lt; \text{RSSI} \leq -90</math></li> <li>• <b>Fast green blink:</b> <math>-90 &lt; \text{RSSI} \leq -75</math></li> <li>• <b>Slow green blink:</b> <math>-75 &lt; \text{RSSI} \leq -60</math></li> <li>• <b>Solid green:</b> RSSI <math>&gt; -60</math></li> </ul>
SVC	Bi-color, green/amber	<p>Service LED indicates the following:</p> <p><b>GSM Module:</b></p> <ul style="list-style-type: none"> <li>• <b>Off:</b> No service</li> <li>• <b>Solid amber:</b> GPRS/EDGE mode is in use</li> <li>• <b>Green slow blink:</b> UMTS mode is in use</li> <li>• <b>Solid green:</b> HSDPA/HSUPA/HSPA+ mode is in use</li> </ul> <p><b>CDMA module:</b></p> <ul style="list-style-type: none"> <li>• <b>Off:</b> No service</li> <li>• <b>Solid amber:</b> 1xRTT</li> <li>• <b>Green slow blink:</b> EVDO Rev 0</li> <li>• <b>Solid green:</b> EVDO Rev A</li> </ul>
SIMx (GSM module)	Bi-color, green/yellow	<p>SIM1 and SIM2 LEDs are controlled by hardware under normal operation. SIM insertion/removal and software setting of the SIM Socket Select bit are decoded by the CPLD to control the LEDs. For diagnostic purposes there is register control of these LEDs in WLANLEDR.</p> <ul style="list-style-type: none"> <li>• <b>Off:</b> No SIM</li> <li>• <b>Yellow:</b> SIM installed but not active</li> <li>• <b>Green:</b> SIM installed and active</li> </ul>



**Table 4** *Release Caveats and Caveats Corrected Reference*

Port or LED Name	Color	Description
WWAN	Green	<p>Indicates the modem status. Driven by the modem, not under software control except for diagnostic purposes. Functionality may be changed by configuring modem.</p> <ul style="list-style-type: none"> <li>• <b>Off:</b> Module not powered</li> <li>• <b>On:</b> Module is powered on and connected but not transmitting or receiving</li> <li>• <b>Slow blink:</b> Module is powered on and searching for connection</li> <li>• <b>Fast blink:</b> Module is transmitting or receiving.</li> </ul> <p>For information on modem settings, see <a href="#">Modem, page 13</a>.</p>
RSSI	Bi-color, green/amber	<p>Indicates the level of signal strength received by the software.</p> <p>LEDs can be lit as follows:</p> <ul style="list-style-type: none"> <li>• <b>Off:</b> RSSI &lt;= -110</li> <li>• <b>Solid amber:</b> -100 &lt; RSSI &lt;= -90</li> <li>• <b>Fast green blink:</b> -90 &lt; RSSI &lt;= -75</li> <li>• <b>Slow green blink:</b> -75 &lt; RSSI &lt;= -60</li> <li>• <b>Solid green:</b> RSSI &gt; -60</li> </ul>
SVC	Bi-color, green/amber	<p>Service LED indicates the following:</p> <p><b>GSM Module:</b></p> <ul style="list-style-type: none"> <li>• <b>Off:</b> No service</li> <li>• <b>Solid amber:</b> GPRS/EDGE mode is in use</li> <li>• <b>Green slow blink:</b> UMTS mode is in use</li> <li>• <b>Solid green:</b> HSDPA/HSUPA/HSPA+ mode is in use</li> </ul> <p><b>CDMA Module:</b></p> <ul style="list-style-type: none"> <li>• <b>Off:</b> No service</li> <li>• <b>Solid amber:</b> 1xRTT</li> <li>• <b>Green slow blink:</b> EVDO Rev 0</li> <li>• <b>Solid green:</b> EVDO Rev A</li> </ul>
SIMx	Bi-color, green/yellow	<p>SIM1 and SIM2 LEDs are controlled by hardware under normal operation. SIM insertion/removal and software setting of the SIM Socket Select bit are decoded by the CPLD to control the LEDs. For diagnostic purposes there is register control of these LEDs in WLANLEDR.</p> <ul style="list-style-type: none"> <li>• <b>Off:</b> No SIM</li> <li>• <b>Yellow:</b> SIM installed but not active</li> <li>• <b>Green:</b> SIM installed and active</li> </ul>

## Supported Cisco Antennas

The antenna is connected to the QMA, panel-mount, 50-ohm connector located on the faceplate of the module. The modem mini-card antenna connector is a U.FL, 50-ohm, with a short 50-ohm coaxial cable to the QMA connector.

For more information about antennas, including installation procedures, see *Cisco and 1120 Connected Grid Router Hardware Installation Guide*.

**Table 4** lists the Cisco antennas that are supported for use with the module and the Cisco 1120 Connected Grid Router.

**Table 4** CGR 1120—Supported Antennas and Cables for Use With the 3G module

Cisco 1120 Connected Grid Router				
Case Description	Indoor Cable	Lightning Arrestor	Outdoor Cable	Antenna
Case 1: 2G/3G Connected Grid Module, 10', 15' or 20' cable thru conduit or building entry panel passthrough, Stick Omni or Directional Flat Panel antenna <ul style="list-style-type: none"> <li>QMA(f), qty 2</li> </ul>	RA-QMA(m) to N(m), LMR-240-DB, 10', qty 2 <ul style="list-style-type: none"> <li>37-1351-02</li> <li>CAB-L240-10-QMA-N</li> </ul>	None	Same cable as indoor cable, i.e. single cable runs from inside to outside, through conduit.	4G Omni Stick, N(f), qty 2 <ul style="list-style-type: none"> <li>07-1166-01</li> <li>ANT-4G-OMNI-OUT-N</li> </ul>
	RA-QMA(m) to N(m), LMR-240-DB, 15', qty 2 <ul style="list-style-type: none"> <li>37-1352-02</li> <li>CAB-L240-15-QMA-N</li> </ul>			3G, 806-960 MHz, 1710-2170 MHz, Flat Panel Antenna, 10/11 dBi, MPN PCTEL FP8241805-10VP, qty 2 <ul style="list-style-type: none"> <li>07-1162-01</li> <li>ANT-3G-PNL-OUT-N</li> </ul>
	RA-QMA(m) to N(m), LMR-240-DB, 20', qty 2 <ul style="list-style-type: none"> <li>37-1353-02</li> <li>CAB-L240-20-QMA-N</li> </ul>			
Case 2: 2G/3G Connected Grid Module, Indoor Cable, Lightning Arrestor, Outdoor Cable, Stick Omni or Directional Flat Panel antenna <ul style="list-style-type: none"> <li>QMA(f), qty 2</li> </ul>	RA-QMA(m) to N(m), LMR-240-DB, 10', qty 2 <ul style="list-style-type: none"> <li>37-1351-02</li> <li>CAB-L240-10-QMA-N</li> </ul>	Lightning Arrestor, N(f)-N(f), qty 2 <ul style="list-style-type: none"> <li>07-1158-01</li> <li>CGR-LA-N-N</li> </ul>	RA-N(m) to N(m), LMR-400-DB, 20', qty 2 <ul style="list-style-type: none"> <li>37-xxxx-01</li> <li>CAB-L400-20-N-N</li> </ul>	4G Omni Stick, N(f), qty 2 <ul style="list-style-type: none"> <li>07-1166-01</li> <li>ANT-4G-OMNI-OUT-N</li> </ul>
			RA-N(m)-N(m), LMR-600-DB, 30' <ul style="list-style-type: none"> <li>37-yyyy-01</li> <li>CAB-L600-30-N-N</li> </ul>	3G, 806-960 MHz, 1710-2170 MHz, Flat Panel Antenna, 10/11 dBi, MPN PCTEL FP8241805-10VP, qty 2 <ul style="list-style-type: none"> <li>07-1162-01</li> <li>ANT-3G-PNL-OUT-N</li> </ul>
Case 3. 2G/3G Connected Grid Module, Low Profile Antenna with Integrated 15" coax cable, Mounted to top of Utility Cabinet Roof <ul style="list-style-type: none"> <li>QMA(f), qty 2</li> </ul>	None	Connector Adaptor, QMA(m)-TNC(f), MPN H+S 33_QMA-TNC-50-1, qty 2 <ul style="list-style-type: none"> <li>CPN</li> <li>PID</li> </ul>	None	

## Supported Cisco Cables

Table 5 lists insertion loss information and operating frequency levels for the Ultra-Low-Loss (ULL) LMR 200 cables, and LMR 400 cables available from Cisco for use with the 2G/3G Connected Grid module.

You can use the RG-174/U type cables to adapt the modem external antenna connection to any of the modules cables and antennas.

**Table 5** Cisco Extension Cables for 3G module

Cisco Product Number	Cable Length	Insertion Loss	Frequency (MHz)
3G-CAB-ULL-20	20 ft (6 m)	1.50 dB max. @ 2000 MHz	700-2700 MHz
3G-CAB-ULL-50	50 ft (15 m)	3.50 dB max. @ 2000 MHz	700-2700 MHz
3G-CAB-LMR240-25	25 ft (7.5 m)	3.35 dB max. @ 2000 MHz	700-2700 MHz

## 3G Module Models

Table 6 describes the available models and the frequencies supported by the 3G GSM module.

**Table 6** Cisco 3G Wireless DGM Model Descriptions and Supported Frequencies

SKU ID	Description	Region	Frequency Bands
CGM-3G-HSPA-A	AT&T (MC8705)	North America	<ul style="list-style-type: none"> <li>GSM/GPRS/EDGE: 850/900/1800/1900 MHz</li> <li>UMTS(WCDMA)/HSPA+: 850/900/1900/2100 MHz</li> </ul>
CGM-3G-HSPA-G	ROW (Rest of World) (MC8705)	Canada, Europe, Australia, South America, other	<ul style="list-style-type: none"> <li>GSM/GPRS/EDGE: 850/900/1800/1900 MHz</li> <li>UMTS(WCDMA)/HSPA+: 850/900/1900/2100 MHz</li> </ul>

Table 7 describes the available models and the frequencies supported by the 3G CDMA modules.

**Table 7** Cisco 3G Wireless DGM Model Descriptions and Supported Frequencies

SKU ID	Description	Region	Frequency Bands
CGM-3G-EVDO-V	Verizon (MC5728)	North America	800 MHz and 1900 MHz
CGM-3G-EVDO-S	Sprint (MC5728)	North America	800 MHz and 1900 MHz
CGM-3G-EVDO	CDMA Generic (MC5728)	North America	800 MHz and 1900 MHz

## Interfaces

The module includes the following physical interfaces to the host:

- **Power**—Supplied to the module by the host

- **Wireless disable**—As described in the PCI-Express Mini Card specification
- **LED output**—As described in the PCI-Express Mini Card specification.
- **Antenna**—U.FL RF connector for the Rx/Tx path. For more details
- **USIM**—Supported through the interface connector. The USIM cavity/connector needs to be placed on the host device for this feature
- **USB**—Only communication interface to the host for data, control, and status information

## Radio Frequency Interface

The Radio Frequency (RF) interface consists of two QMA connectors on the faceplate labeled *MAIN* and *AUX*. The main antenna is mandatory; it both transmits and receives RF. The second *AUX* QMA connector is for the optional RX Diversity. Since the GPS of the module is not used, the GPS Antenna connector must be terminated with a 50-ohm termination.

## Environmental Specifications

The following are operating temperature ranges for the module:

**Table 8**      **Module Environmental Specifications**

Router	Specifications
CGR1120	-40°C to 60°C (-40° F to 140° F)

Table 9 lists the environmental specifics of the 3G module.

**Table 9**      **Module Environmental Specifications**

Environmental—Operational	Specifications
Temperature—standard range	-5°C to 55°C (-41°F to 131°F)
Temperature—long term	-40°C to 60°C (-40°F to 140°F)
Temperature—short term (up to 16 hours)	-40°C and 85°C (-40°F to 185°F)
Altitude	Up to 1500 meters
Humidity	RH95% non condensed
Vibration	1.0 g from 1.0 to 150 Hz
Shock	30 G half sine 6 ms and 11 ms
Seismic	GR63-Core, Zone 4

## Power Specifications

There are two switching DC-DC power supplies on the Cisco Connected Grid 2G/3G Wireless Connected Grid Module. The module 12V-to-3.3V DC-DC switcher and modem 12V-to-3.3V DC-DC switcher can both be power margined through CLI commands.

**Note**

Power cables are self-shielded—there is no additional shielding required.

The 2G/3G Connected Grid module has 12V power rail and 3.3V stan-by power provided by the host system. It has two 3.3V DC-DC converters on the 12V power rail: one for the module and the other for the modem.

**Table 10**      *Power Specifications*

Power Source	Description
12V power rail	Max 1A (based on current draw from 2 DC-DC converters below)
3.3V modem	Peak current 3.75A, average power: 3W (based on average current of ~0.8A)
3.3V module	Peak current 500mA typical: 200mA (for LEDs and integrated circuitry)
3.3V standby	Peak current 500mA (for quack2/temp sensor)

## Modem

### GSM

The MC8705 PCI Express mini-card modem provides EDGE, GPRS, GSM, WCDMA, HSDPA, HSUPA, and HSPA+ wireless radio connectivity technologies over the following frequency bands:

**Table 11**      *Frequency Bands*

Power Source	Description
<b>GSM, GPRS, EDGE</b>	850 MHz, 900 MHz, 1800 MHz, 1900 MHz
<b>UMTS/WCDMA/HSDPA/HSUPA/HSPA+</b>	800 MHz, 850 MHz, 900 MHz, 1900 MHz, 2100 MHz
<b>Receive diversity</b>	Optimized for diversity on 800, 850, 900, 1900 and 2100 MHz

MC8705 includes a RF connector jack for use with host antennas (it does not have integrated antennas) which is used for the main Rx/Tx path.

The MC8705 modem supports the following GSM features:

- Cellular packet data profile
- Traditional modem COM port support for CSD and AT commands (concurrent with NDIS)
- Suspend/resume
- SIM application tool kit with proactive SIM commands
- Static and Dynamic IP address. The network may assign fixed IP address or dynamically assign one using DHCP (Dynamic Host Configuration Protocol).

## CDMA

The MC5728V PCI Express Mini Card modem provides voice, features, and CDMA and 1xEVDO wireless radio connectivity technologies with dual-band diversity radio supporting the following frequency bands:

- 800 MHz cellular
- 1900 MHz PCS

MC5728V includes two RF connector jacks for use with host antennas. (It does not have integrated antennas.) One connector is used for the main Rx/Tx path.

MC5728V supports the following RF features:

- Dual-band for 800 MHz cellular and 1.9 GHz PCS bands
- Diversity support for the 800 MHz cellular and 1.9 GHz PCS bands
- CDMA authentication as specified in CDMA 1X
- IS-95A/B and CDMA 1X Release 0/A
- IS-856 1xEVDO Revision A

The MC5728V Mini Card supports communication with the host through the USB interface. The USB interface can be dynamically configured to operate in one of two modes:

- Non-MUX mode
- MUX mode

The MC5728V Mini Card supports three logical interfaces:

- Data channel—Supports AT command and PPP packet exchange during data calls
- Control channel—Supports modem control and status, call processing, and event notification
- Diagnostic channel—Supports the QUALCOMM Diagnostic Monitoring protocol used by support tools

## GSM Module SIM Interface

Two adjacent SIM sockets (SIM1 and SIM2) are available on the card. The SIM card stores critical GSM subscriber authentication information.

The two SIM cards are powered by the modem and operates at 5 MHz. The SIM card is a 3.3 V device, and has 2.8 V power applied to its power pin.

Through the software you can control which SIM is connected to the modem. Only one SIM can be connected to the modem at any time. The SIM switching circuit also provides the option of disconnecting both SIMs from the modem. The 3G Debug and SIM Control register controls the SIM connections.

By setting the SIM Socket Enable and the SIM Socket Select bit, you can control the signal and power connections from the modem to the SIM card.

Table 12 shows the options used to connect to SIM0 and SIM1 cards:

**Table 12**      *Specifications to Connect to the SIM Sockets*

SIM Socket Enable	SIM Socket Select	State
0	—	No SIM connected
1	0	SIM0 connected
1	1	SIM1 connected

For information on installing and removing the SIM card, see [Installing and Removing the SIM Card \(GSM Module\)](#), page 17.

## Voltage Monitoring State Machine

A state machine in the 3G module monitors the VCC supply and the voltage conditions that trigger state changes.

## Temperature Monitoring State Machine

The state machine in the Cisco Connected Grid 2G/3G Wireless Connected Grid Module monitors the embedded module temperature.

## Data Rates

The actual throughput rates depend on many different factors, but the theoretical rates for the technologies follows:

**Table 13**      *GSM and CDMA Data Rates*

GSM	CDMA
HSPA+: 21.1 Mbps Down; 5.76 Mbps Up	EVDO Rev A: 3.1 Mbps Down; 1.8 Mbps Up

## USB Interface

A USB interface is the only communication path used by the router and the module at full-speed (12 Mbps) and high-speed (480 Mbps) data rates. The host acts as the USB host device to interface with the module. The module uses the USB standard to control the sleep and wake-up states.

## Memory Specifications

The memory specifications of the module are listed in [Table 14](#).

**Table 14**      **Specifications to Connect to the SIM Sockets**

Memory Type	Minimum	Maximum
DDR2 SDRAM	1Gb (128 Mb)	NA (1Gb is sufficient for the Linux SDK design and modem firmware upgrade)
DDR2 SDRAM for fixed platforms	512 Mb (384 Mb for IOS and 128 Mb for the Linux)	—

## Module Power States

The module has the following power states:

- **Normal mode** (default mode)—Module is active. Receive and Transmit modes are possible. In this state:
  - The module is fully powered
  - The module is capable of placing/receiving calls or establishing data connections on the wireless network
  - The USB interface is fully active



**Note** The module unit defaults to the Normal state when VCC is first applied.

- **Low power mode** (*airplane mode*)—The module is active, but RF is disabled. In this state, RF (both Rx and Tx) is disabled on the module, but the USB interface is still active. This state is controlled through the host interface by the following software commands:
  - **+CFUN=0** command (AT Command Set for User Equipment (UE) (Release 6))
  - **CDMA module:** CNS\_RADIO\_POWER [0x1075] (CDMA CnS Reference (Document 2130754))
  - **GSM module:** CNS\_RADIO\_POWER [0x1075] (MC87XX Modem CnS Reference (Document 2130602))
  - **Disable Modem** command (MC87XX Modem CnS Reference (Document 2130602))



**Note** The module goes from normal mode into low-power mode to suspend RF activity. This occurs when the module's supply voltage exceeds either the high or low limits. The module returns to normal mode to resume RF activity. It occurs when the module's supply voltage returns from critical to normal limits.

- **Disconnected mode**—No power to the module. The host power source is disconnected from the module and all voltages associated with the module are at 0 V.

CGR 1120 and CGR 1240 controls the power to the module, therefore the host can stay powered on and cut the power in order to put the module into the disconnected state.



The module begins a shutdown sequence and powers off if it has been in a powered-on state for more than 10.5 seconds and the host device drives the W\_Disable# signal low for:

- MC8775/MC8775V:  $\geq 50$  ms
- Other devices:  $\geq 500$  ms

## Installing and Removing the SIM Card (GSM Module)

Two GSM (Global System for Mobile Communications) SIM card sockets for storing critical subscriber authentication information. The SIM card can be installed in either of the two available sockets accessible on the front panel of the Cisco Connected Grid 3G Module.



**Note**

You must reload the system after installing or changing the SIM card.

## Preventing Electrostatic Discharge Damage

Electrostatic Discharge (ESD) damage can occur when electronic cards or components are handled improperly, and can result in complete or intermittent failures.

To prevent ESD damage:

- Always use an ESD wrist or ankle strap and ensure that it makes good skin contact
- Connect the equipment end of the strap to an unfinished chassis surface
- Place a removed compact SIM card on an antistatic surface or in a static shielding bag. If the card will be returned to the factory, immediately place it in a static shielding bag
- Avoid contact between the card and clothing. The wrist strap protects the card from ESD voltages on the body only; ESD voltages on clothing can still cause damage
- Do not remove the wrist strap until the installation is complete



**Warning**

**Only trained and qualified personnel should be allowed to install, replace, or service this equipment.**  
Statement 1030



**Caution**

For safety, periodically check the resistance value of the antistatic strap. The measurement should be between 1 and 10 megohms (Mohms).

## Installing the SIM Card (GSM Module)

To install the SIM card:

- Step 1** Using a Phillips-head screwdriver, loosen the screw that secures the SIM slot cover in place. Rotate the cover downward so it exposes the SIM slot.
- Step 2** Insert the SIM card with the key (notch) positioned on the right-hand side. The SIM card will come in contact with the metal contacts in the socket.

**Figure 5** Installing the SIM Socket

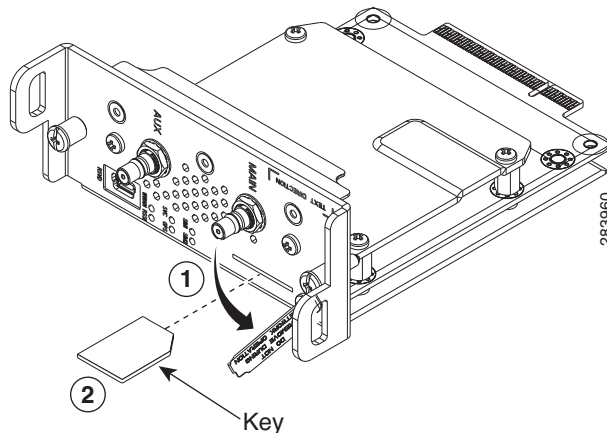

- Step 3** Firmly insert the card until it clicks into place.
- Step 4** Rotate the cover back in place and secure by tightening the screw.

## Removing the SIM Card (GSM Module)

To remove the SIM card, open the cover press the card and it will eject. Remove the card and replace the cover.

## Installing and Removing the 3G Module

Some Cisco Connected Grid 2G/3G Wireless Connected Grid Modules are installed into the host router at the factory.



**Note**

After replacing or installing a module in the router, you must update the label (on the router exterior) that lists the module types contained in the router. The label must list the FCC ID number and the IC Certification number for each module installed in the router.

## Before You Begin Installation

Before installing the module, verify that the following guidelines have been met:

- Clearance to the I/O-side view is such that the LEDs can be easily read.
- Cabling is away from sources of electrical noise, such as radios, power lines, and fluorescent lighting fixtures. Make sure that the cabling is away from other devices that might damage the cables.
- Airflow around the switch module and through the vents is unrestricted.
- Temperature around the unit does not exceed 140°F (60° C). If the switch module is installed in a closed or multi-rack assembly, the temperature around it might be higher than normal room temperature.

- Relative humidity around the switch module does not exceed 95 percent (non-condensing).
- Altitude at the installation site is not higher than 10,000 feet.
- For 10/100 and 10/100/1000 fixed ports, cable lengths from the switch module to connected devices are not longer than 328 feet (100 meters).

## Installation Warning Statements

This section includes the basic installation warning statements. Translations of these warning statements appear in the *Regulatory Compliance and Safety Information for Cisco Connected Grid Router 1000 Series Routers* documents.



**Warning**

**This unit is intended for installation in restricted access areas. A restricted access area can be accessed only through the use of a special tool, lock and key, or other means of security.**

Statement 1017



**Warning**

**Only trained and qualified personnel should be allowed to install, replace, or service this equipment.**

Statement 1030



**Warning**

**To prevent the system from overheating, do not operate it in an area that exceeds the maximum recommended ambient temperature of:**

**140°F (60°C)** Statement 1047



**Warning**

**This equipment is supplied as “open type” equipment. It must be mounted within an enclosure that is suitably designed for those specific environmental conditions that will be present and appropriately designed to prevent personal injury resulting from accessibility to live parts. The interior of the enclosure must be accessible only by the use of a tool.**

**The enclosure must meet IP 54 or NEMA type 4 minimum enclosure rating standards.** Statement 1063



**Warning**

**This equipment is intended to be grounded to comply with emission and immunity requirements. Ensure that the switch functional ground lug is connected to earth ground during normal use.**

Statement 1064



**Warning**

**To prevent airflow restriction, allow clearance around the ventilation openings to be at least: 1.75 in. (4.4 cm)** Statement 1076

## Installing the 3G Module

To install the module into the router:



**Caution**

The module can NOT be hot swapped—to install the module, you must first power down the host router.

- Step 1** Before you install the Cisco Connected Grid 3G Module into the host CGR 1240 router, you must power down the router as described in the *Hardware Installation Guide* of your router.
- Step 2** Insert the module into the slot. (CGR 1120 and CGR 1240 shown.)

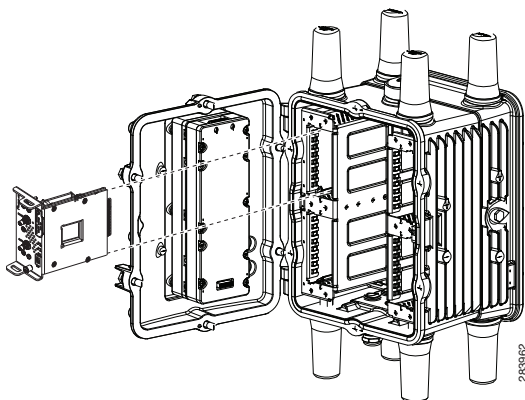
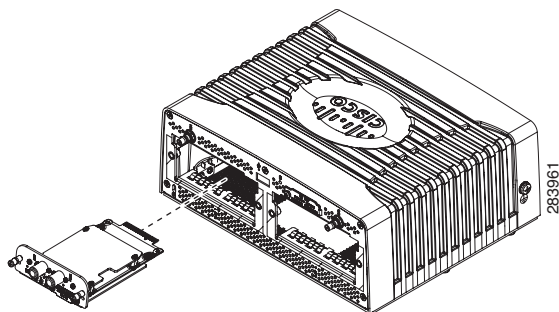

- Step 3** Using a screwdriver, secure the two captive screws into place. Tighten to 5 to 8 pound-force inches (lbf-in.).

## Removing the Module

To remove the module from a router:



**Caution**

The module can NOT be hot swapped—to install the module, you must first power down the host router.

- Step 1** Before you remove the Cisco Connected Grid 3G Module from the host CGR 1240 router, you must power down the router as described in the *Hardware Installation Guide* of your router.

- Step 2** Using a screwdriver, loosen the two captive screws on the Cisco Connected Grid 3G Module.
- Step 3** Gently pull the module out of the slot.
- 

## Regulatory and Compliance Information

For regulatory compliance and safety information for the module, refer to the *Connected Grid Router 2000 Series Regulatory Compliance and Safety Information* document.

<http://www.cisco.com/en/US/docs/routers/access/2000/CGR2010/hardware/rcsi/rcsiCGR2000series.html>

## Software Overview

This section covers the following topics:

- [3G Overview, page 21](#)
- [UMTS/GSM Data Network Overview, page 22](#)
- [CDMA Data Network Overview, page 23](#)

## 3G Overview

3G is defined by the ITU (International Telecommunications Union-2000 (IMT-2000) as mobile radio systems capable of supporting peak data rates of:

- 144 Kb/s or more in a large cell (where the users may be miles from the Base Stations) with high speed vehicular users
- 384 Kb/s or more for urban small cells (where the user may be only a few city blocks from a Base Station) with pedestrian users
- 2 Mb/s or more for indoor (or very small cells, where the user may be only a few hundred feet from a Base Station) with primarily stationary users

**Note**

On the Cisco Connected Grid Module—3G HSPA+/UMTS/GSM/GPRS/EDGE module (CGM-3G-HSPA-A), the ping packet size limit is 1472 bytes.

---

## UMTS/GSM Data Network Overview

Global System for Mobile Communication (GSM) is the most widely used digital mobile phone system and the de facto wireless telephone standard in Europe. It is based on the specification from European Telecommunications Standards Institute (ETSI). Originally defined as a pan-European open standard for a digital cellular telephone network to support voice, data, text messaging and cross-border roaming. GSM is now one of the world's main 2G digital wireless standards.

GSM was primarily designed for voice and was circuit switched, but due to the popularity of cellular networks and the great demand for data services, General Packet Radio Service (GPRS) was introduced as a packet-switched data overlay over the GSM radio network. The radio and network resources of GPRS are accessed only when data needs to be transmitted between the GPRS mobile user and the GPRS network.

GSM models are based on 3GPP, and they support HSPA (High-Speed Uplink Packet Access (HSUPA) and High-Speed Downlink Packet Access (HSDPA)), UMTS (Universal Mobile Radio Service), EDGE (Enhanced Data Rates for Global Evolution), and GPRS.

GPRS introduced several new network nodes into the GSM architecture for packet switching, they form the Mobile Packet Core. The Mobile Packet Core includes the Serving GPRS Support Node (SGSN) and the GPRS Gateway Support Node (GGSN). The SGSN is the node which, in some ways, carries out the same function as the Foreign Agent in Mobile IP—it tunnels IP packets towards the GGSN and detunnels packets back from the GGSN. It also carries out mobility managed and billing. GGSN is the node that carries out the role in the GPRS equivalent to the Home Agent in Mobile IP. The GGSN provides the connectivity to the IP network and the SGSN, is responsible for IP address assignment, and is the default router for the connected User Equipment (UE).

Figure 6 shows a GSM network and the network elements it contains.

**Figure 6** GSM Network Overview

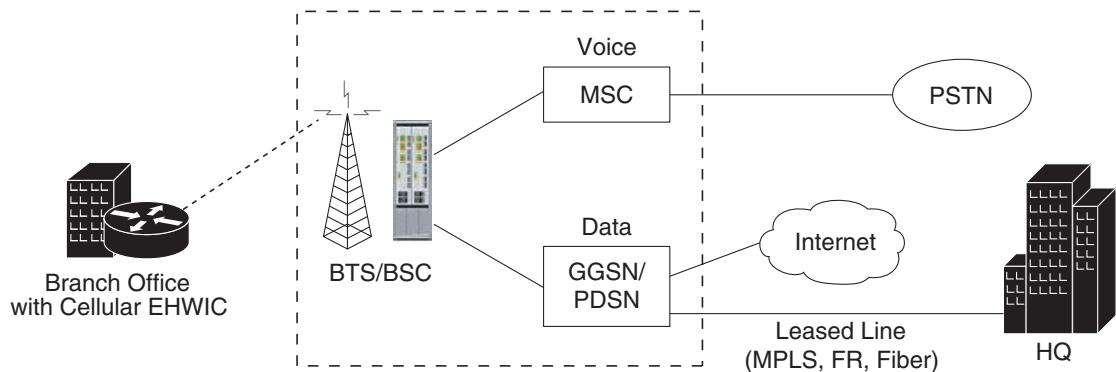

- Carrier Network**
- BTS: Base Transceiver Stations
  - BSC: Base Station Controller
  - MSC: Mobile Switching Center
  - SGSN: Service GPRS Support Node
  - GGSN: Gateway SPRS Support Node

230351

The Base Tranceiver Station (BTS) and Base Station Controller (BSC) are located at the Cell site and are the common nodes for both voice and data services. They provide the radio or the physical layer connectivity between the mobile user and the mobile network. As the BSC voice and data traffic get

segregated, the voice traffic goes to the Mobile Switching Center (MSC), while the data traffic is sent to the GGSN. From the GGSN, the data packets either go directly to the internet or they can be backhauled to the customer data center for a VPN connection.

Universal Mobile Telecommunications System (UMTS) evolved from GSM and is a 3G wireless system that delivers high-bandwidth data and voice services to mobile users. UMTS has a new air interface based on Wideband Code Division Multiple Access (W-CDMA) and an IP core network based on general-packet radio service (GPRS). The nodes in a UMTS network are almost the same as that of a GSM/GPRS network. BTS and BSC have been renamed to Node B and Radio Network Controller (RNC), respectively.

UMTS addresses the growing demand of mobile and Internet applications for new capacity in the overcrowded mobile communications sky. The new network increases transmission speed to 2 Mbps per mobile user and establishes a global roaming standard.

UMTS (Universal Mobile Telecommunication System) (W-CDMA) is standardized by 3GPP and offers the following:

- W-CDMA radio access technology, in addition to the existing GSM and GPRS radio access networks.
- W-CDMA uses 5 MHz bandwidth radio carriers. Up to 384kb/s initially. Capable of 2 Mb/s, but not offered commercial yet.
- HSPA is an upgrade to W-CDMA (includes HSDPA (High Speed Downlink Packet Access) and HSUPA (High-Speed Uplink Packet Access).
  - HSDPA: Various categories support up to 10 Mb/s
  - HSUPA: uplink speed up to 5.76 Mb/s

High Speed Packet Access (HSPA) is a collection of two mobile protocols—High Speed Downlink Packet Access (HSDPA) and High Speed Uplink Packet Access (HSUPA)—that extends and improves the performance of existing WCDMA/UMTS protocols. HSDPA and HSUPA provide increased performance by using improved modulation schemes and by refining the protocols by which 3G modem and base stations communicate.

These improvements lead to a better utilization of the existing radio bandwidth provided by WCDMA. HSPA improves the end-user experience by increasing peak data rates of up to 14 Mbit/s in the downlink and 5.76 Mbit/s in the uplink. It also reduces latency and provides up to five times more system capacity in the downlink and up to twice as much system capacity in the uplink, reducing the production cost per bit compared to original WCDMA protocols.

## CDMA Data Network Overview

The Code Division Multiple Access (CDMA) is a digital cellular network developed to deliver high-speed and improved wireless data service through increased capacity by allowing users to share a band of frequencies. CDMA is being adopted by many administrators for cellular networks due to its greater throughput which is six times that of Time Division Multiple Access (TDMA-) or Frequency Division Multiple Access (FDMA)-based systems.

A typical CDMA network includes terminal equipment, mobile termination, base transceiver station (BTS), base station controller (BSC), packet data serving node (PDSN), and other data network entities. The PDSN is the interface between a BSC and a internet gateway.

A typical CDMA network includes a PDSN and a branch office with the 3G wireless Modular and Fixed Cisco ISRs. The branch office connects to a radio tower and a BTS. The BTS connects to a BSC, which contains a component called the packet control function (PCF). The PCF communicates with the Cisco PDSN for data communication and with the mobile switching center (MSC) for voice.

CDMA technology uses spread radio spectrum transmission with concurrent multiple access by dividing the spectrum shared by multiple users by using channels using unique codes. These codes are filtered by the receiver using a correlator that accepts only signals (streams of bits) from the desired code channel. CDMA also employs graceful signal degradation, multipath resistance, inherent frequency diversity, and interference rejection.

Evolution-Data Optimized (EVDO), also known as 1xEVDO, is a telecommunications standard that employs the use of multiplexing, CDMA, and TDMA. EVDO was standardized by 3GPP2 (3rd-Generation Partnership Project 2), the global 3G wireless standard specification, and has been adopted by many mobile service providers who had been previously using CDMA. 1x EVDO (1x Evolution Data Optimized) supports up to 2.4 Mb/s downlink and 153.6 Kb/s uplink in Revision 0, while Revision A supports 3.1 Mb/s downlink and 1.8 Mb/s uplink.

CDMA2000, also known as CDMA2000 1x and as 1xRTT (1 times Radio Transmission Technology), had evolved from IS-95 (cdmaOne), the first CDMA-based digital cellular (2D) standard, with which CDMA2000 is backward-compatible. The suffix 1x means that it uses the same 1.25 MHz bandwidth as IS-95 has always used and supports up to 144 Kb/s, initially. CDMA2000 was standardized by the 3GPP2 committee and is based on the standards of CDMA2000 1X, CDMA2000 EVDO Rel. 0, CDMA2000 EVDO Rev. A, and CDMA2000 EVDO Rev. B.

The Cisco Connected Grid Module—3G EVDO Rev A/0/1xRTT module is based on 3GPP2 and supports the CDMA2000 EVDO Rev A and Rel. 0, and CDMA2000 1x operating standards.

## Configuring the Module

The module is configured using the system software. This section covers the following topics:

- [Prerequisites, page 25](#)
- [Configuration Restrictions, page 25](#)
- [Configuring the GSM Module, page 25](#)
- [Configuring the CDMA Module, page 26](#)
- [show Commands, page 27](#)
- [Data Account Provisioning, page 30](#)
- [GSM Cellular Interface Configuration, page 31](#)
- [CDMA Cellular Interface Configuration, page 32](#)
- [Configuring WAN Backhaul Redundancy, page 33](#)



### Note

The 3G module can be plugged into slots 3 to 6 of Cisco 1240 Connected Grid Router, therefore the interface names used to configure the module can be 3/1, 4/1, 5/1, or 6/1. Interface 3/1 is used in the configuration examples in this section.



### Note

The 3G module can be plugged into slots 3 or 4 of Cisco 1120 Connected Grid Router, therefore the interface names used to configure the module can be 3/1 or 4/1. Interface 3/1 is used in the configuration examples in this section.



## Prerequisites

To configure the 3G module, you must meet the following requirements:

- Have 2G/3G network coverage where your router will be physically located. For a complete list of supported carriers, see the product data sheet.
- Subscribe to a service plan with a wireless service provider and obtain a SIM card.
- Install the SIM card before configuring the 3G module. For instructions on how to install the SIM card, see the section, [Installing the SIM Card \(GSM Module\)](#), page 17.

## Configuration Restrictions

The following restrictions apply to configuring the Cisco Connected Grid 3G Module:

- Data connection can be originated only by the module.
- Throughput: Due to the shared nature of wireless communications, the experienced throughput varies depending on the number of active users or congestion in a given network.
- Cellular networks have higher latency compared to wired networks. Latency rates depend on the technology and carrier. Latency may be higher because of network congestion.
- Any restrictions that are a part of the terms of service from your carrier.

## Configuring the GSM Module

### Step 1: Creating a GSM Profile

Use the **cellular 3/1 gsm profile** command to configure a GSM profile:

```
Router# cellular 3/1 gsm profile create 1 <Access Point Name> [<authentication type  
<username> <password>]
```

- Use *<authentication type>* if username and password is configured.
- Use *<username>* if required by your carrier.
- Use *<password>* if required by your carrier.

See also [GSM Cellular Interface Configuration](#), page 31.

### Step 2: Configuring a Chat Script

Use the **chat-script** command to configure a GSM chat script:

```
Router(config)# chat-script <chat-script name> PROFILE1
```

### Step 3: Configuring Dialer Parameters

Use the **dialer** commands to configure dialer parameters:

```
Router(config)# interface dialer 1
Router(config-if)# dialer pool 1
Router(config-if)# dialer string <chat-script name>
Router(config-if)# dialer persistent
Router(config-if)# no shutdown
```



#### Note

To unconfigure dialer persistent, you must delete the profile by using the command, **cellular 3/1 gsm profile delete 1**.

### Step 4: Configuring Cellular Parameters

Use the **dialer pool-member** command to configure cellular parameters:

```
Router(config)# interface cellular 3/1
Router(config-if)# dialer pool-member 1
```

### Step 5: Saving Configuration

Use the **shutdown** and **no shutdown** commands to save configuration on the interface:

```
Router(config)# interface cellular 3/1
Router(config-if)# shutdown
Router(config-if)# no shutdown
```

## GSM Unconfiguration

All commands, except dialer persistent, can be unconfigured with the **no** option. The dialer persistent profile must be deleted with the command, **cellular 3/1 gsm profile delete 1**.

See also [Step 3: Configuring Dialer Parameters](#), page 26.

## Configuring the CDMA Module

### Step 1: Configuring a Chat Script

Use the **chat-script** command to configure a GSM chat script:

```
Router(config)# chat-script <chat-script name> ATDT#777
```

### Step 2: Configuring Dialer Parameters

Use the **dialer** commands to configure dialer parameters:

```
Router(config)# interface dialer 1
Router(config-if)# dialer pool 1
Router(config-if)# dialer string <chat-script name>
Router(config-if)# dialer persistent
Router(config-if)# no shutdown
```

### Step 3: Configuring PPP Encapsulation

Use the **feature ppp** command to configure PPP encapsulation:

```
Router(config)# feature ppp
```

### Step 4: Configuring Cellular Parameters

Use the **dialer pool** and **encapsulation ppp** commands to configure cellular parameters:

```
Router(config)# interest cellular 3/1
Router(config-if)# dialer pool-member 1
Router(config-if)# encapsulation ppp
```

### Step 5: Saving Configuration

Use the **shutdown** and **no shutdown** commands to save configuration on the interface:

```
Router(config)# interface cellular 3/1
Router(config-if)# shutdown
Router(config-if)# no shutdown
```

## show Commands

To view your configurations, use the following **show** commands:

- **show ip interface brief**
- **show interface cellular 3/1**
- **show cellular 3/1 ?**
  - **all**—Display cellular information
  - **connection**—Display cellular connection status
  - **hardware**—Display cellular hardware information
  - **leds**—Display LED information
  - **network**—Display cellular network information
  - **profile**—Display cellular interface profile
  - **radio**—Display cellular radio information
  - **band**—Display radio band information

### show cellular 3/1 all (GSM Module)

Shows consolidated information about the modem, profiles created, radio signal strength, network security, and so on.



#### Note

---

The RSSI should be better than -90 dBm for steady and reliable connection.

---

```
Router# show cellular 3/1 all
```

```
Hardware Information
=====
```

```

Modem Firmware Version = T1_0_3_2AP R361 CNSZXD00000061 2011/04/15 17:40:48
Modem Firmware Built = 04/15/11
Modem Hardware Version = 1.0
International Mobile Subscriber Identity (IMSI) = 0123456063
International Mobile Equipment Identity (IMEI) = 353567040032469 <-- Unique identifier for module
Factory Serial Number (FSN) = CC3291006141001
Modem status = Online
Current Modem Temperature = 33 deg C
Current Temperature State = Normal
    
```

Profile Information  
 =====

```

--- Profile 1 details ---
Status = Activated
Default: Yes
PDP Type: IPv4
Profile IP: 192.0.2.0 <-- Profile details stored on the modem
Profile APN: isp.cingular
Authentication: CHAP
Profile UserName:
Profile Password:
    
```

Data Connection Information  
 =====

```

Data Transmitted = -1603896208 bytes
Data Received = 208880986 bytes
Profile 1, Packet Session Status = ACTIVATED <-- State of the connection
    
```

Network Information  
 =====

```

Modem status = Online
Service status = Normal
Service type = Combined
Country Initials = 1
Network name =
MCC = 1, MNC = 1 <-- Mobile country code, mobile network code
Location Area Code (LAC) = 128
Routing Area Code (RAC) = 0
Cell ID = 1
Primary Scrambling Code = 100
PLMN Selection = Automatic
    
```

Radio Information  
 =====

```

Current band = WCDMA_I_IMT2000 <-- Current band/channel/RSSI
Radio power mode = On
Channel number = 10563
Band selected = Auto
Current RSSI = -56 dBm
    
```

Band Information  
 =====

```

Number of bands: 5 <-- Bands supported by the modem are listed below
    
```

```

Band 1: GSM EGSM DCS
Band 2: Unknown Band Group
Band 3: GSM ALL
Band 4: Unknown Band Group
Band 5: AUTO BAND

```

## show cellular 3/1 all (CDMA Module)

Shows consolidated information about the modem, profiles created, radio signal strength, network security, and so on.



### Note

---

The RSSI should be better than -90 dBm for steady and reliable connection.

---

```

Router# show cellular 3/1 all

Hardware Information
=====

Modem Firmware Version = p2813301
Modem Firmware Built = 06-24-10
Modem Hardware Version = MC5728V Rev 1.0
International Mobile Subscriber Identity (IMSI) = 5555550032
Electronic Serial Number (ESN) = 60D22706 <-- Unique identifier for module
Modem status = Online
Current Modem Temperature = 31 deg C
Current Temperature State = Normal

Profile Information
=====

Electronic Serial Number (ESN) = 60D22706 <-- Unique identifier for module
Activation Status = active
Activation Date = 20110925
Phone Number (MDN) = 5555550213
Number of data profiles configured: 1
Current Active Data Profile: 1
NAI (Network Access Identifier) = 5555550213@vzw3g.com
MN-HA SS = enabled
MN-HA SPI = 300
MN-AAA SS = enabled
MN-AAA SPI = 2
Reverse Tunneling Preference = enabled
Home Address = 0.0.0.0
Primary Home Agent Address = 255.255.255.255
Secondary Home Agent Address = 255.255.255.255

Data Connection Information
=====

Phone Number of outgoing call = 5555550213
Data Transmitted = 14041 bytes
Data Received = 14041 bytes

Network Information
=====

```

```
Current Roaming Status = Not Roaming
Current Idle Digital Mode = No Service
Current System Identifier (SID) = 40
Current System Identifier (NID) = 0
Serving Base Station Longitude = 0 deg 0 min 0 sec
Serving Base Station Latitude = 0 deg 0 min 0 sec
```

```
Radio Information
=====
```

```
Current band = CDMA_CLASS1,CDMA_CLASS1 <-- Current band/channel/RSSI
Radio power mode = On
Channel number = 548
Current RSSI = -82 dBm
```

## Data Account Provisioning



**Note**

---

For the Cisco Connected Grid 3G Module, the numbering is **3/1** for all commands.

---



**Note**

---

To provision your modem, you must have an active wireless account with a service provider and a SIM card installed.

---

To provision your data account, see the following topics:

- [Verifying Signal Strength and Service Availability, page 30](#)
- [Activating the Module Using OTASP \(CDMA Module\), page 31](#)

## Verifying Signal Strength and Service Availability

To verify the signal strength and service availability on your modem, use the following commands in privileged EXEC mode. See also [show Commands, page 27](#).

- **show cellular3/1 network**
- **show cellular 3/1 radio**
- **show cellular 3/1 profile**
- **show cellular 3/1 all**
- **show cellular 3/1 led**

## DETAILED STEPS

Step	Command	Purpose
Step 1	<b>show cellular 3/1 network</b>	Displays information about the carrier network, cell site, and available service.
Step 2	<b>show cellular 3/1 radio</b>	Shows the radio signal strength. <b>Note</b> The RSSI should be better than -90 dBm for steady and reliable connection.
Step 3	<b>show cellular 3/1 profile</b>	Shows information about the modem data profiles created.
Step 4	<b>show cellular 3/1 security</b>	Shows the security information for the modem, such as SIM and modem lock status.
Step 5	<b>show cellular 3/1 all</b>	Shows consolidated information about the modem, profiles created, radio signal strength, network security, and so on.

## Activating the Module Using OTASP (CDMA Module)

To activate the module using Over-The-Air Service Provisioning (OTASP), use the **cellular 3/1 cdma activate otasp \*22899** command.

**Note**

Do not hit a Enter (carriage return) until provisioning is complete—you will see “Over the air provisioning complete; Result = Success.” See below.

```
Router# cellular 3/1 cdma activate otasp *22899
Beginning OTASP activation
OTASP number is *22899
Router# <-- Do not hit Enter key-- provisioning is in process.
OTA State = SPL unlock, Result = Successprovising
OTA State = Profile downloaded, Result = Success
OTA State = MDN downloaded, Result = Success
OTA State = Parameters committed to NVRAM, Result = Success
Over the air provisioning complete; Result = Success <-- Activation successful. Hit Enter to return to prompt
Router#
```

To verify that the account has been provisioned and the modem has been activated, use the **show cellular 3/1 profile** command in EXEC mode:

```
Router# show cellular 3/1 profile
* - Default profile
```

## GSM Cellular Interface Configuration

To configure the cellular interface:

- 
- Step 1** Create a profile on the interface 3/1 using the **cellular** command:
- ```
Router# cellular 3/1 gsm profile create 1 <Access Point Name> [<username> <password>]
```
- Step 2** Configure terminal:

```
Router# configure terminal
```

- Step 3** Create a chat script using the **chat-script** command and assign it to your profile:

```
Router(config)# chat-script <chat-script name> PROFILE1 #
```

- Step 4** Configure dialer parameters on the interface by using the **interface** command to enter interface configuration mode, and the **dialer** command to configure **persistent** dialer mode.

```
Router(config)# interface dialer 1
Router(config-if)# dialer pool 1
Router(config-if)# dialer string <chat-script name>#
Router(config-if)# dialer persistent
```

- Step 5** Configure cellular parameters on the interface by using the **interface** and **dialer** commands:

```
Router(config)# interface cellular 3/1
Router(config-if)# dialer pool-member 1
```

- Step 6** Shutdown and no shut the interface using the **shutdown** and **no shutdown** commands:

```
Router(config)# interface cellular 3/1
Router(config-if)# shutdown
Router(config-if)# no shutdown
```

## GSM Dialer Persistent Unconfiguration

All commands can be unconfigured with the **no** option, however, the dialer persistent configuration condition cannot be unconfigured. Therefore, to remove dialer persistent, the profile must be deleted with the cellular configuration command as follows:

```
Router# cellular 3/1 gsm profile delete 1
```

## CDMA Cellular Interface Configuration

The following example shows how to configure the cellular interface:

- Step 1** Configure a chat script using the **chat-script** command:

```
Router(config)# chat-script <chat-script name> ATDT#777 <-- ATDT777# is the chat-script name.
```

- Step 2** Configure dialer parameters by using the **dialer** command:

```
Router(config)# interface dialer 1
Router(config-if)# dialer pool 1
Router(config-if)# dialer string ATDT777#
Router(config-if)# dialer persistent
```

- Step 3** Configure PPP encapsulation by using the **feature** command:

```
Router(config)# feature ppp
```

- Step 4** Configure the cellular parameters by using the **encapsulation** command:

```
Router(config)# interface cellular 3/1
Router(config-if)# dialer pool-member 1
Router(config-if)# encapsulation ppp
```

- Step 5** Save changes by issuing **shutdown** and **no shutdown** on the interface:



```
Router(config)# interface cellular 3/1
Router(config-if)# shutdown
Router(config-if)# no shutdown
```

## Configuring WAN Backhaul Redundancy

For information on configuring WAN backhaul redundancy, see *Cisco 1000 Series Connected Grid Routers Unicast Routing Software Configuration Guide*.

## Configuration Example

The following example shows a configuration that includes information on TACACS+ security, OSPF (Open Shortest Path First), OSPF v3, DHCP (Dynamic Host Configuration Protocol), DHCP v6, a tunnel, virtual tunnel, QoS, Internet Protocol Security (IPSec), a static IP address when a tunnel interface (3/1) is configured, the interfaces (Ethernet, serial, cellular, WPAN, and WiFi), dialer, and chat script.

```
Router# show running-configuration

!Command: show running-config
!Time: Sun Aug 14 00:36:25 2011

version 5.2(1)
hostname Router
vdc Router id 1
  limit-resource vlan minimum 16 maximum 4094
  limit-resource vrf minimum 2 maximum 4096
  limit-resource port-channel minimum 0 maximum 768
  limit-resource u4route-mem minimum 9 maximum 9
  limit-resource u6route-mem minimum 24 maximum 24
  limit-resource m4route-mem minimum 58 maximum 58
  limit-resource m6route-mem minimum 8 maximum 8

feature privilege
feature tacacs+
feature crypto ike
crypto ike domain ipsec
  policy 10
    group 1
      lifetime seconds 660
      identity hostname
feature ospf
feature ospfv3
feature dhcp
feature tunnel
feature crypto ipsec virtual-tunnel
feature dhcpv6
feature ppp

username adminbackup password 5 ! role network-operator
username admin password 5 $1$fMmnWu6t$Aawk/SH5wmErCjCwnxeyb. role network-admin
enable secret 5 $1$454cdd6$a08d10dc3fdb2f6f
no password strength-check
ip domain-lookup
tacacs-server host 4.4.4.5 key 7 "fewhg"
aaa group server tacacs+ tactical
  server 4.4.4.5
```

```

crypto key param rsa label IPSEC_IDENTITY_BLUE modulus 2048 exportable
crypto ca trustpoint IPSEC_IDENTITY_BLUE
    rsakeypair IPSEC_IDENTITY_BLUE 2048
    revocation-check none
class-map type qos match-all ignore
    match precedence 0
class-map type qos match-all packet
    match packet length 1500
class-map type qos match-all critical
    match dscp 46
class-map type qos match-all matchall
    match precedence 1
    match dscp 10
class-map type qos match-any matchany
    match dscp 10,26
class-map type qos match-all priority
    match precedence 3
policy-map type qos ignore
    class ignore
        set dscp 1
policy-map type qos packet
    class packet
        set precedence 5
policy-map type qos critical
    class critical
        set dscp 10
policy-map type qos matchall
    class matchall
        set precedence 5
policy-map type qos matchany
    class matchany
        set dscp 46
policy-map type qos priority
    class priority
        set dscp 46
priority level 3
copp profile strict
snmp-server user admin auth md5 0x5f66c5f7cde8de86eecb2008de9126f8 priv 0x5f66c5
f7cde8de86eecb2008de9126f8 localizedkey engineID 128:0:0:9:3:0:34:189:224:46:129
rmon event 1 log trap public description FATAL(1) owner PMON@FATAL
rmon event 2 log trap public description CRITICAL(2) owner PMON@CRITICAL
rmon event 3 log trap public description ERROR(3) owner PMON@ERROR
rmon event 4 log trap public description WARNING(4) owner PMON@WARNING
rmon event 5 log trap public description INFORMATION(5) owner PMON@INFO

vrf context test
vrf context management
crypto ipsec profile MyProfile
    set transform-set MyTransformSet
    set pfs group1
    set security-association lifetime seconds 120
    set security-association lifetime kilobytes 2560
crypto ipsec transform-set MyTransformSet esp-gcm 256
vlan 1

no ip dhcp relay

interface Tunnel0
    ip address 4.0.0.1/24
    tunnel mode ipsec ipv4
    tunnel source cellular3/1
    tunnel destination 192.168.168.2
    tunnel protection ipsec profile MyProfile
    no shutdown

```

```
interface Tunnel1
  ipv6 address 2001:b:b:bc::1/64
  ipv6 mld join-group ff38:40:2011:dead:beef:cafe:0:1
  ipv6 router ospfv3 1 area 0.0.0.0
  tunnel source Tunnel0
  tunnel destination 4.0.0.2
  no shutdown
  ipv6 dhcp relay destination 2001:a:b:c::100

interface Tunnel5
  no shutdown

interface Ethernet2/1
  mac-address 0022.bde0.3201
  ip address 2.12.54.10/16
  no shutdown

interface Ethernet2/2
  mtu 1496
  mac-address 0022.bde0.3202
  ip address 172.27.161.54/25
  ipv6 address 2001:dead:beef:cafe::2/64
  no shutdown

interface Ethernet2/3
  mtu 1496
  mac-address 0022.bde0.3203

interface Ethernet2/4
  mtu 1496
  mac-address 0022.bde0.3204

interface Ethernet2/5
  mtu 1496
  mac-address 0022.bde0.3205

interface Ethernet2/6
  mtu 1496
  mac-address 0022.bde0.3206

interface Ethernet2/7
  mtu 1496
  mac-address 0022.bde0.3207

interface Ethernet2/8
  mtu 1496
  mac-address 0022.bde0.3208
  no shutdown

interface serial1/1
  physical-layer async

interface serial1/2
  physical-layer async

interface cellular3/1
  no shutdown
  encapsulation ppp
  dialer pool-member 1

interface wimax5/1
  shutdown
  no description
```

```
pkm version none
pkm crypto algorithm none

interface wpan4/1
 no shutdown
 ipv6 address 2011:dead:beef:cafe::0/64
 rpl prefix 2011:dead:beef:cafe::0/64
 ipv6 dhcp relay client-interface

interface wifi2/1
 clock timezone PST -8 0
 line console
 line vty
 boot kickstart bootflash:/cgr1000-uk9-kickstart.5.2.0.CG1.0.194.SSA.gbin sup-1
 boot system bootflash:/cgr1000-uk9.5.2.0.CG1.0.194.SSA.gbin sup-1
 router ospfv3 1
  address-family ipv6 unicast
 ip route 0.0.0.0/0 cellular3/1
 ip route 223.255.0.0/16 2.12.0.1
 ipv6 route 2001:420:7bf:5f::/64 Tunnel1
 ipv6 route 2001:a:b:c::/64 Tunnel1
 line tty 1
  device-role dce
 line tty 2
  device-role dce

interface Dialer1
 dialer persistent
 dialer pool 1
 dialer string gsm

chat-script gsm PROFILE1

cgdm
 registration start trustpoint ://2001:420:7bf:5f::800:9121
 no logging console
```

## Additional References

Consult the following resources for related information about the 3G module or for technical assistance.

## Hardware Overview and Installation Documents

- *Cisco Connected Grid Modules*  
[http://www.cisco.com/en/US/products/ps10984/prod\\_module\\_series\\_home.html](http://www.cisco.com/en/US/products/ps10984/prod_module_series_home.html)
- *Cisco CGR 1240 Hardware Installation Guide*
- *Cisco CGR 1120 Hardware Installation Guide*
- *Cisco CGS1240 Getting Started Guide*

## Supported Cisco Antennas and Accessories Documents

- *Cisco 3G Omnidirectional Outdoor Antenna (3G-ANTM-OUT-OM)*  
<http://www.cisco.com/en/US/docs/routers/access/wireless/hardware/notes/ant3gom.html>
- *Cisco Multiband Omnidirectional Panel-Mount Antenna (3G-ANTM-OUT-LP)*  
<http://www.cisco.com/en/US/docs/routers/access/wireless/hardware/notes/antcmLP.html>

## Cisco System Software Commands Documents

- *Cisco Connected Grid Device Manager User Guide*
- *Cisco System Software*  
[http://www.cisco.com/en/US/products/ps9372/tsd\\_products\\_support\\_series\\_home.html](http://www.cisco.com/en/US/products/ps9372/tsd_products_support_series_home.html)
- *Configuring Cisco EHWIC-3G-EDVO-x*  
[http://www.cisco.com/en/US/docs/routers/access/1800/1861/software/feature/guide/mrwls\\_evdo.html](http://www.cisco.com/en/US/docs/routers/access/1800/1861/software/feature/guide/mrwls_evdo.html)
- *Cisco 1000 Series Connected Grid Routers Unicast Routing Software Configuration Guide*

## Regulatory, Compliance, and Safety Information

- *Cisco Network Modules and Interface Cards Regulatory Compliance and Safety Information*  
<http://www.cisco.com/en/US/docs/routers/access/interfaces/rcsi/IOHrcsi.html>

## Technical Assistance

The Cisco Support and Documentation website provides online resources to download documentation, software, and tools. Use these resources to install and configure the software and to troubleshoot and resolve technical issues with Cisco products and technologies. Access to most tools on the Cisco Support and Documentation website requires a Cisco.com user ID and password.

<http://www.cisco.com/cisco/web/support/index.html>

# Troubleshooting and Diagnostics

This section provides the necessary background information and resources available for troubleshooting the 2G/3G Connected Grid module.

For LED descriptions, see *Ports and LEDs, page 7*.

- [Debug Commands, page 38](#)
- [Modem AT Test Commands, page 38](#)
- [Checking Signal Strength, page 39](#)
- [Verifying Service Availability \(GSM Module\), page 39](#)
- [Successful Call Setup \(GSM Module\), page 41](#)
- [Retrieving the Electronic Serial Number, page 41](#)
- [Converting Hexadecimal ESN to Decimal Notation, page 42](#)

## Debug Commands

The following are sample output for the **debug cellular** commands:

```
Router# debug cellular ?
<0-10>  Debug level
```

```
Router# debug cellpm ?
all      All debugging
error    Error cellpm debug
trace    Trace cellpm debug
```

```
Router# debug chat ?
error    Error chat debug
trace    Trace chat debug
```

```
Router# debug dialer ?
all      All debugging
error    Error dialer debug
trace    Trace dialer debug
```

## Modem AT Test Commands

The following is the **test cellular** AT command.



**Note**

---

CDMA Module: Accessing the AT commands will end the connection.

---

```
Router# test cellular 2/1 atcommands
ati
Device busy - issue +++ to abort connection before issuing AT commands
+++

NO CARRIER
ati
ati
Manufacturer: Sierra Wireless, Inc.
Model: MC5728V Rev 1.0 (5)
Revision: p2813301,10 [Jun 24 2010 12:18:30]
```

```
QCOM: SWI6085_FP.01.28
BOOT: SWI6085_PP.01.33.01 2010/06/24 15:02:12
APPL: SWI6085_PP.01.33.01 2010/06/24 15:02:12
USBD: SWI6085_GENERIC.00.01
USB VID: 0x1199 PID: 0x0028
ESN: 0x60D2271B
+GCAP: +CIS707-A, CIS-856, CIS-856-A, +MS, +ES, +DS, +FCLASS
SKU: 0x82BB5
```

```
OK
Exit <----- To return to the Console prompt.
```



**Note**

To return to the Console prompt: Press **exit**.

Table 15 show useful AT commands:

**Table 15 AT Commands**

| AT Command   | Description                                    |
|--------------|------------------------------------------------|
| AT!HSDCAT?   | To get programmed DPA Category                 |
| AT!HSUCAT?   | To get programmed UPA Category                 |
| AT+BAND?     | To find the band                               |
| AT+CPIN?     | To get SIM card status                         |
| AT!GSTATUS?  | Status                                         |
| AT!SCACT=1,1 | Connect to network                             |
| ATI          | Get hardware and software details of the modem |

## Checking Signal Strength

If the Received Signal Strength Indication (RSSI) level is very low (for example, if it is less than -110 dBm), follow these steps:

- Step 1** Check the antenna connection. Make sure the QMA connector is correctly threaded and tightened.
- Step 2** If you are using a remote antenna, move the antenna cradle and check if the RSSI has improved.
- Step 3** Contact your wireless service provider to verify that there is service availability in your area.

## Verifying Service Availability (GSM Module)

The following is sample **show cellular 3/1 all** command output for a scenario where the antenna is disconnected and a modem data profile has not been created.

The error in this case has been highlighted below:

```
Router# show cellular 3/1 all
```

Hardware Information  
 =====

Modem Firmware Version = T1\_0\_3\_2AP R361 CNSZXD00000061 2011/04/15 17:40:48  
 Modem Firmware Built = 04/15/11  
 Modem Hardware Version = 1.0  
 International Mobile Subscriber Identity (IMSI) = 345678901  
 International Mobile Equipment Identity (IMEI) = 357115040054053  
 Factory Serial Number (FSN) = CC3200115221007  
 Modem status = Online  
 Current Modem Temperature = 0 deg C  
 Current Temperature State = Normal

Profile Information  
 =====

\* - Default profile <-- Indicates that no profile is present

Data Connection Information  
 =====

Data Transmitted = 5616 bytes  
 Data Received = 9424 bytes  
 Profile 1, Packet Session Status = ACTIVATED  
 IP Address = 192.0.2.0

Network Information  
 =====

Current Service Status = No service, Service Error = None <-- Indicates no service—not connected to network  
 Current Service = Combined  
 Packet Service = None  
 Packet Session Status = Inactive  
 Current Roaming Status = Home  
 Network Selection Mode = Automatic  
 Country = USA, Network = Cinglr  
 Mobile Country Code (MCC) = 310  
 Mobile Network Code (MNC) = 380  
 Location Area Code (LAC) = 6042  
 Routing Area Code (RAC) = 255  
 Cell ID = 0  
 Primary Scrambling Code = 0  
 PLMN Selection = Automatic

Radio Information  
 =====

Current Band = None, Channel Number = 0  
 Current RSSI = -110 dBm <-- Indicates either no antenna or bad antenna, or out of network

Band Information  
 =====

Number of bands: 5  
 Band 1: GSM EGSM DCS  
 Band 2: Unknown Band Group  
 Band 3: GSM ALL  
 Band 4: Unknown Band Group  
 Band 5: AUTO BAND



## Successful Call Setup (GSM Module)

The following are the single-line debug output for key steps while establishing a successful connection.

### Cellular Driver Started

The **debug cellular trace** command output provides the following output:

```
...
2009 Jan 1 07:53:37.201398 cellpm: Cellular start driver: ifindex 29180000
...
```

### Modem is Enabled

The **debug cellular trace** command output provides the following output:

```
...
2009 Jan 1 07:53:37.232260 cellpm: Receive modem enabled notification
...
```

### Chat Script Invoked

The **debug chat trace** command output provides the following output:

```
...
2009 Jan 1 07:53:37.265470 dialer: CHAT SCRIPT gsm1_x profile 1
...
```

### Packet Session Activated Successfully

The **debug cellular trace** command output provides the following output:

```
...
2009 Jan 1 07:53:39.724489 cellpm: Send MTS - PKT SESS ACTIVATED to dialer
...
```

### Stop Dialer Since Connection is Established

The **debug dialer trace** command output provides the following output:

```
...
2009 Jan 1 07:53:39.724766 dialer: Session activated. Dialer1 stop dialing
...
```

## Retrieving the Electronic Serial Number

If your network provider requests the 11-digit decimal equivalent of your Electronic Serial Number (ESN), you must retrieve your ESN, then convert it to decimal notation. See also, [Converting Hexadecimal ESN to Decimal Notation, page 42](#).

The ESN number is located directly on the modem label in hexadecimal notation. It can also be retrieved using the Cisco IOS CLI using the **show cellular 3/1 all** command.

## GSM Module Sample Output

The sample output below shows the IMEI number:

```
Router# show cellular 3/1 all

Hardware Information
=====
Modem Firmware Version = T1_0_3_2AP R361 CNSZXD00000061 2011/04/15 17:40:48
```

```

Modem Firmware Built = 04/15/11
Modem Hardware Version = 1.0
International Mobile Subscriber Identity (IMSI) = 0123456063
International Mobile Equipment Identity (IMEI) = 353567040032469 <-- Unique identifier for module
Factory Serial Number (FSN) = CC3291006141001
Modem status = Online
Current Modem Temperature = 33 deg C
Current Temperature State = Normal
    
```

## GSM Module Sample Output

The sample output below shows the ESN number:

```

Router# show cellular 3/1 all

Hardware Information
=====
Modem Firmware Version = p2813301
Modem Firmware Built = 06-24-10
Modem Hardware Version = MC5728V Rev 1.0
International Mobile Subscriber Identity (IMSI) = 4082280032
Electronic Serial Number (ESN) = 60D22706 <-- Unique identifier for module
Modem status = Online
Current Modem Temperature = 31 deg C
Current Temperature State = Normal
    
```

## Converting Hexadecimal ESN to Decimal Notation

If your network provider requests the 11-digit decimal equivalent of your Electronic Serial Number (ESN), you must retrieve your ESN, then convert it to decimal notation. See also, [Retrieving the Electronic Serial Number, page 41](#).

To convert the ESN number from hexadecimal notation to decimal notation:

- 
- Step 1** Start with the 8-digit HEX ESN # obtained from the label or using CLI, for example 0x603C9854. This number consists of two parts:
    - 0x60—Serial number
    - 3C9854—Manufacturer’s code
  - Step 2** Convert manufacturer’s code to decimal as shown:
 

Hexadecimal 0x60 equals decimal 96.

If the decimal value is two digits only, prepend it with a zero to expand it to three digits.

Manufacturer’s code is thus 096.
  - Step 3** Convert the serial number to decimal, as shown in the example below:
 

Hexadecimal 0x3C9854 equals decimal 3971156.

If decimal value is less than 8 digits, add enough zeros to make it into an 8 digit number.

Serial number is thus 03971156.
  - Step 4** To obtain complete 11-digit decimal ESN notation, combine manufacturer code and serial number:
 

Manufacturer code: 096

Serial #: 03971156

Decimal ESN: 09603971156

---

---

Cisco and the Cisco Logo are trademarks of Cisco Systems, Inc. and/or its affiliates in the U.S. and other countries. A listing of Cisco's trademarks can be found at [www.cisco.com/go/trademarks](http://www.cisco.com/go/trademarks). Third party trademarks mentioned are the property of their respective owners. The use of the word partner does not imply a partnership relationship between Cisco and any other company. (1005R)

Any Internet Protocol (IP) addresses and phone numbers used in this document are not intended to be actual addresses and phone numbers. Any examples, command display output, network topology diagrams, and other figures included in the document are shown for illustrative purposes only. Any use of actual IP addresses or phone numbers in illustrative content is unintentional and coincidental.

No combinations are authorized or intended under this document.

© 2011 Cisco Systems, Inc. All rights reserved.

