



Cisco Connected Grid WPAN Module for CGR1000 Series Installation and Configuration Guide

First Published: January, 2012
OL-26243-01

This guide explains how to install the Wireless Personal Area Network (WPAN) module, as well as how to configure the Cell Relay (release 3.7). This document contains the following topics:

- [Kit Contents, page 2](#)
- [Features, page 2](#)
- [Hardware Overview, page 2](#)
- [Installing and Removing the Module, page 6](#)
- [Regulatory and Compliance Information, page 8](#)
- [Software Overview, page 8](#)
- [Additional References, page 17](#)
- [Technical Assistance, page 18](#)



Warning

Only trained and qualified personnel should be allowed to install, replace, or service this equipment.
Statement 1030



Note

The Cisco Connected Grid WPAN Module is installed in the router at the factory. Only Cisco Systems or Itron, Inc. technicians may install, uninstall, or configure Connected Grid Modules.

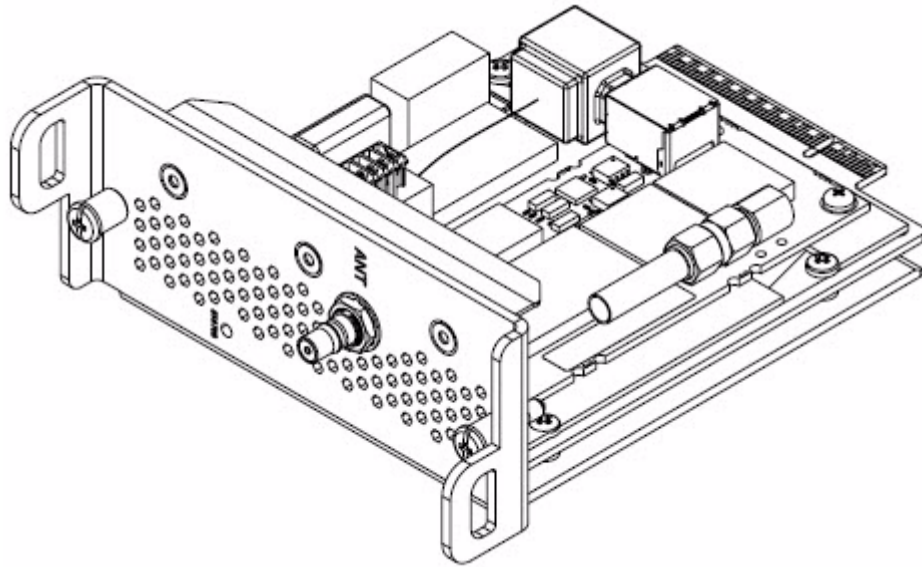
FIRST REVIEW DRAFT – CISCO CONFIDENTIAL**Figure 1** Cisco Connected Grid WPAN Module

Kit Contents

For system requirements, important notes, limitations, open and resolved bugs, and last-minute documentation updates, see the Release Notes on Cisco.com. For translations of the warnings that appear in this document, see the *Regulatory Compliance and Safety Information* document for your router on Cisco.com.

When using the online publications, see the documents that match the Cisco system software version running on the WPAN module.

Features

The WPAN module provides the following functionality:

- Acts as bridge between the WPAN port manager and the radio module via the Cisco Connected Grid 1240 Router's FPGA module
- Monitors the health and of the WPAN module
- Resets and reprograms the WPAN module
- Collects statistics and status of the WPAN module

Hardware Overview

The WPAN module hardware is based on Itron's Trifecta Communications Module, which contains a Cortex-M3, microcontroller, Texas Instruments CC1101 RF Transceiver operating in the 900 MHz ISM band, Semtech SX1781 PLL Frequency Synthesizer, and RF Micro Devices RF6559 front-end module.

This section covers the following topics:

FIRST REVIEW DRAFT – CISCO CONFIDENTIAL

- [Front Panel, page 3](#)
- [LED, page 3](#)
- [Supported Cisco Antenna, page 4](#)
- [Cisco Supported Cables, page 4](#)
- [Configuration, page 5](#)
- [Default Parameters, page 5](#)
- [Environmental Specifications, page 6](#)
- [Power Specifications, page 6](#)

Front Panel

Figure 2 shows the front panel of the WPAN module.

Figure 2 **Front Panel of the Cisco Connected Grid WPAN Module**

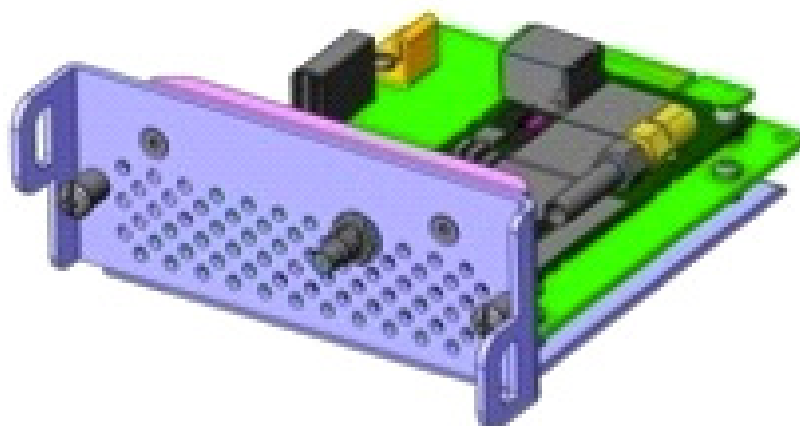

LED

Table 1 lists the LED indicator and describes the behavior. The LED provides a visual indicator of the available services.

Table 1 **LED Indicator**

LED Name	Color	Description
Status	Green	Indicates the RF status: <ul style="list-style-type: none"> • Off: Module is not powered • On: System is functional - RF mesh interface is up (if installed) • Blinking: Hardware is functional - RF mesh interface is up (if installed)

FIRST REVIEW DRAFT – CISCO CONFIDENTIAL**Supported Cisco Antenna**

The antenna is connected to the TNC, panel-mount, 50 Ohm connector located on the faceplate of the WPAN module.

For more information about antennas, including installation steps, see the *Cisco Connected Grid 1240 Router Installation Guide*.

[Table 2](#) lists the Cisco antenna this is supported for use with the WPAN module and the Cisco Connected Grid 1120 Router.

Table 2 CGR 1240 Supported Antennas and Cables for use with the WPAN Module

Description	Outdoor Cable	Antenna
<ul style="list-style-type: none"> WPAN Module 10.5' or 17.5' cable through conduit 	Single cable passes thru conduit from inside to outside bldg.	900 MHz, 3G, 806-960 MHz, 1710-2700 MHz, Monopole Antenna, Chassis Mounted, Omni-directional, ANT-MP-INT-OUT-M, qty 1

Cisco Supported Cables

[Table 3](#) lists the external cable options, and internal cable/adaptor available from Cisco for use with the WPAN module.

Table 3 Cisco External and Internal Cables for WPAN Module

External Cable Options	Internal Cable/Adapter	Antenna Options
<ul style="list-style-type: none"> LMR-400-DB, 20' CAB-L400-20-N-N LMR-600B-DB, 30' CAB-L600-30-N-N 	<ul style="list-style-type: none"> LMR-100, 10.5" CAB-L100-10-Q-M, qty 1 LMR-100-17.5" CAB-L100-17-Q-M, qty 1 N Bulkhead adapters plus lightning arrestors, qty 2 	900 MHz ISM Band, Omni Stick, ANT-RF-OMNI-OUT-N, qty 1

Interfaces

The WPAN module includes the following physical interfaces to the host:

- **Single RF Transceiver**—supports IEEE 802.15.4g in the 915 MHz ISM. The RF transceiver is used to provide mesh networking connectivity.
- **Single Serial UART**—used to communicate with the Cisco Connected Grid 1240 Router host processor via the onboard FPGA I/O module, providing framing control and buffering for UART data communications.
- **GPIO**—control and data communications

FIRST REVIEW DRAFT – CISCO CONFIDENTIAL

Configuration

The configuration parameters are set by the Connected Grid Network Management System (CG-NMS), through a series of CLI commands. Statistics on network traffic is also retrieved from the interface via the RF port manager, through the use of the CLI.

Default Parameters

Table 4 lists the interface default values.

Table 4 *List of Interface Default Values*

Parameters	Default Value
Admin State	Enabled
802.14.4 Raw Data Rates	155 kbps (78.6 kbps with FEC on by default)
RF Transmit Power	28 dBm
Channels	52 (frequency hopping)
Link Retransmission Retries	16
Mac Backoff Timer	

Table 5 lists the default frequencies for each channel.

Table 5 *List of Default Frequencies for each Channel*

Channel #	Channel f. (MHz)	Channel #	Channel f. (MHz)	Channel #	Channel f. (MHz)	Channel #	Channel f. (MHz)
1	902.250	14	908.750	27	915.250	40	921.750
2	902.750	15	909.250	28	915.750	41	922.250
3	903.250	16	909.750	29	916.250	42	922.750
4	903.750	17	910.250	30	916.750	43	923.250
5	904.250	18	910.750	31	917.250	44	923.750
6	904.750	19	911.250	32	917.750	45	924.250
7	905.250	20	911.750	33	918.250	46	924.750
8	905.750	21	912.250	34	918.750	47	925.250
9	906.250	22	912.750	35	919.250	48	925.750
10	906.750	23	913.250	36	919.750	49	926.250
11	907.250	24	913.750	37	920.250	50	926.750
12	907.750	25	914.250	38	920.750	51	927.250
13	908.250	26	914.750	39	921.250	52	927.750

Environmental Specifications

Following are the operating temperature range for the router

Connected Grid 1120 Router: -40° C to 60° C (-40° F to 140° F)

Connected Grid 1240 Router: -35° C to 150° C (-31° F to 302° F)

Table 6 lists the environmental specifications for the Connected Grid WPAN Module.

Table 6 *WPAN Module Environmental Specifications*

Environmental—Operational	Specifications
Temperature—standard range	-5°C to 55°C (-41°F to 131°F)
Temperature—long term	-40°C to 60°C (-40°F to 140°F)
Temperature—short term (up to 16 hours)	-40°C and 95°C (-40°F to 195°F)
Altitude	Up to 1500 meters
Humidity	RH95% non condensed
Vibration	1.0 g from 1.0 to 150 Hz
Shock	30 G half sine 6 ms and 11 ms
Seismic	GR63-Core, Zone 4

Power Specifications

The Connected Grid WPAN Module has a 12V power rail and 3.3V standby power provided by the host system.

Installing and Removing the Module

Before installing the WPAN module, verify the following guidelines have been met:

- Clearance to the I/O side view is such that the LED can be read
- Airflow around the WPAN module and through the vents is unrestricted
- Temperature around the unit does not exceed 140°F (60° C). If the WPAN module is installed in a closed or multi-rack assembly, the temperature around it might be higher than normal room temperature.
- Relative humidity around the WPAN module does not exceed 95% (non-condensing)
- Altitude at the installation site is not higher than 10,000 feet
- After replacing or installing a module in the router, you must update the label (on the router exterior) that lists the module types contained in the router. The label must list the FCC ID number and the IC Certification number for each module installed in the router.

FIRST REVIEW DRAFT – CISCO CONFIDENTIAL**Installation Warning Statements**

This section includes the basic installation warning statements. Translations of these warning statements appear in the *Regulatory Compliance and Safety Information for Cisco Connected Grid Router 1000 Series Routers* documents.

**Warning**

This unit is intended for installation in restricted access areas. A restricted access area can be accessed only through the use of a special tool, lock and key, or other means of security.

Statement 1017

**Warning**

Only trained and qualified personnel should be allowed to install, replace, or service this equipment.

Statement 1030

**Warning**

To prevent the system from overheating, do not operate it in an area that exceeds the maximum recommended ambient temperature of:

140°F (60°C) Statement 1047**Warning**

This equipment is supplied as “open type” equipment. It must be mounted within an enclosure that is suitably designed for those specific environmental conditions that will be present and appropriately designed to prevent personal injury resulting from accessibility to live parts. The interior of the enclosure must be accessible only by the use of a tool.

The enclosure must meet IP 54 or NEMA type 4 minimum enclosure rating standards. Statement 1063

**Warning**

This equipment is intended to be grounded to comply with emission and immunity requirements. Ensure that the switch functional ground lug is connected to earth ground during normal use.

Statement 1064

**Warning**

To prevent airflow restriction, allow clearance around the ventilation openings to be at least: 1.75 in. (4.4 cm) Statement 1076

Installing the WPAN Module

To install the module into an available slot in the Cisco Connected Grid 1120 Router or the Cisco Connected Grid 1240 Router:

**Caution**

The module can NOT be hot swapped—to install the module, you must first power down the module.

Step 1

Before you install (or remove) the Connected Grid WPAN Module from the host router, you must power down the router as described in the *Hardware Installation Guide* of your router.

Step 2

Insert the WPAN module in the slot.

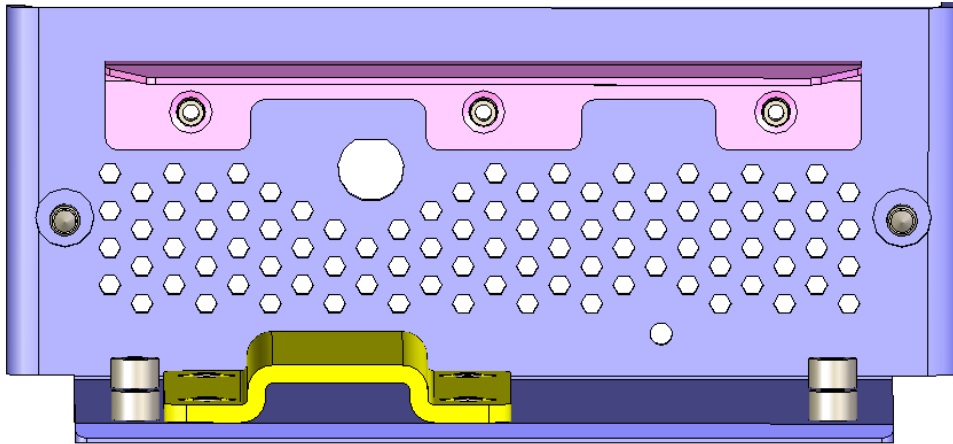
FIRST REVIEW DRAFT – CISCO CONFIDENTIAL

Step 3 Using a screwdriver, secure the two captive screws into place.

Removing the WPAN Module

To remove the WPAN module from a slot in the Cisco Connected Grid 1120 Router, or the Cisco Connected Grid 1240 Router:



Caution

The module can NOT be hot swapped—to install the module, you must first power down the module.

Step 1 Using a screwdriver, loosen the two captive screws on the Connected Grid WPAN Module.

Step 2 Gently pull the WPAN module out of the slot.

Regulatory and Compliance Information

For regulatory compliance and safety information for the WPAN module, refer to the *Connected Grid Router 2000 Series Regulatory Compliance and Safety Information* document:

<http://www.cisco.com/en/US/docs/routers/access/2000/CGR2010/hardware/rcsi/rcsiCGR2000series.html>

Software Overview

The Connected Grid WPAN Module is configured using the Cisco Connected Grid 1240 Router system software. This section covers the following topics:

- [Prerequisites, page 9](#)
- [Configuring the Cell Relay Application, page 9](#)
- [Obtaining the ESN Number to Register the Router to the Collection Engine, page 10](#)

FIRST REVIEW DRAFT – CISCO CONFIDENTIAL

- [Show Commands to Verify the Cell Relay](#), page 10
- [Force Registration using the Command Line](#), page 11
- [Change Communications Module UID from the FAR](#), page 12
- [Debugging Commands to Verify the Cell Relay](#), page 12
- [Additional Debugging Commands](#), page 13
- [Sample Router Configuration](#), page 13

Prerequisites

Connecting to the console port of the Cisco Connected Grid 1240 Router displays the loading sequence. Once the router has completed the boot process, the login prompt displays.



Note

The system takes up to three minutes to come up after you initially login and start configuring the router. Please wait for the prompt before continuing and running CLI commands.

Refer to the *Cisco Connected Grid 1240 Router Configuration Guide* for details on how to bring up and log into the router.

Configuring the Cell Relay Application

This section contains information on enabling the Cell Relay and configuring the Collection Engine IP address.



Note

The configuration in this section is for release 3.7 only.

Enabling the Cell Relay

The Cell Relay is disabled by default, and is required to be enabled for configuration.

```
router# show feature
Feature Name      Instance  State
-----
..... <trimmed>
c1222r            1         disabled
..... <trimmed>

router# config terminal
Enter configuration commands, one per line.  End with CNTL/Z.
Altamont37(config)# feature c1222r
Altamont37(config)# show feature
Feature Name      Instance  State
-----
..... <trimmed>
c1222r            1         enabled
..... <trimmed>
```

**Note**

After the Cell Relay is enabled, you need to wait approximately one minute for the Itron thread to be initialized.

Configuring the Collection Engine IP Address

You are now ready to the configure the Collection Engine IP address:

```
router(config)# c11222r master-relay-address 10.1.1.10
```

Obtaining the ESN Number to Register the Router to the Collection Engine

To successfully register the router to the Collection Engine, you need the ESN number for the router. Based on this ESN number, you can create an Endpoint Definition File (XML file) to add the router into the Collection Engine. Refer to Itron’s OPENWAY Collection Engine documents for more information (https://itron.com/na/PublishedContent/OpenWay_Collection_Engine.pdf).

The following command is used to get the ESN number from the router:

```
router(config)# show c1222r info global
```

State:

```
Registered                : No
CommModuleEnabled         : Yes
ElectronicSerialNumber    : 2.16.840.1.114416.3.8893.14692240
ApTitle                   :
```

Timers:

```
HeartbeatGoodFrequency    : 300 secs
UplinkFailureDisableCommModulePeriod : 28800 secs
DatalinkDownResetCommModulePeriod : 60 mins
CommModuleStatisticsReadPeriod : 10 secs
RegistrationSendDelay      : 0 secs
```

ExceptionHost:

```
ApTitle                   :
AckBroadcastFromExceptionHost : No
```

Build:

```
Version                   : 1.0.31.0 Oct 11 2011 08:12:51
CommModuleVersion         : 14.58
```

```
router(config)#
```

Show Commands to Verify the Cell Relay

You can verify if the router was registered with the Collection Engine successfully by using the commands “show c1222r info globals”, and both “Registered” and “CommModuleEnabled” should show as Yes.

```
router(config)# show c1222r info global
```

State:

```
Registered                : Yes
CommModuleEnabled         : Yes
ElectronicSerialNumber    : 2.16.840.1.114416.3.8893.14692240
ApTitle                   : 2.16.124.113620.1.22.0.1.1.64.10081
```

FIRST REVIEW DRAFT – CISCO CONFIDENTIAL

```

Timers:
  HeartbeatGoodFrequency          : 300 secs
  UplinkFailureDisableCommModulePeriod : 28800 secs
  DatalinkDownResetCommModulePeriod  : 60mins
  CommModuleStatisticsReadPeriod     : 10 secs
  RegistrationSendDelay            : 0 secs

ExceptionHost:
  ApTitle                        : 2.16.124.113620.1.22.0.1.1.64.33
  AckBroadcastFromExceptionHost   : No

Build:
  Version                        : 1.0.9.0 Jul 29 201105:39:40
  CommModuleVersion              : 14.58

```

You can also verify if the master-relay address was configured properly with the following command:

```

router(config)# show c1222r info master-relay
  MasterRelayAddress             : 10.1.1.10
  MasterRelayPriority             : 1
  MasterRelayPort                 : 1153
  MasterRelayInboundConnected    : Yes
  MasterRelayOutboundConnected   : No

```

You can also verify the comm-module information (configuration and status) with the following command:

```

router(config)# show c1222r info comm-module

State:
  Index           : 1
  Name            : TFC CellRelay
  Enabled         : Yes
  RouteToUnknownMAC : Yes

Timers:
  NETRDelay       : 5 secs
  NETTDelay       : 20 secs

Misc:
  IntervalSinceEnabled           : Tue Oct 4 13:53:24 2011
  IntervalSinceDisabled          : -
  LastMessageSent                : Tue Oct 4 14:00:38 2011
  CommModuleLastMessageReceived  : Tue Oct 4 14:03:39 2011
  IntervalSinceDatalinkReset     : 2957 secs
  IntervalSinceBaudrateChange    : 2933 secs
  IntervalSinceStatisticsRead    : 5 secs
  MessageQueueDepth              : 0
  LastACSEMessageFailCode       : 0
  IntervalSinceLastACSEMessageFail : -

```

Force Registration using the Command Line

If the Cell Relay did to register to the Collection Engine, you can force registration with the following command to ensure there are two TCP connection to the Collection Engine:

```

router(config)# show sockets connection tcp
:
tcp      ESTABLISHED 0          25.0.0.2(1153)
         default      0          10.1.1.10(3137)

tcp      ESTABLISHED 0          25.0.0.2(34118)

```

FIRST REVIEW DRAFT—CISCO CONFIDENTIAL

```
default      0      10.1.1.10(1153)
```

You can now force registration:

```
router(config)# test c1222r register
```

Change Communications Module UID from the FAR

You can change the UID from the FAR to synchronize all the meters with the FAR, using the same UID:

```
router# sh c1222r info rflanconfig
MacAddress: 7647340
UtilityId: a6
router# conf t
Enter configuration commands, one per line. End with CNTL/Z.
router(config)# c1222r rflanconfig utility-id 0xC9
SetUtilityID: OK
Scheduled comm module reset. Takes about 1 minute to complete.
router(config)# sh c1222r info rflanconfig
MacAddress: 7647340
UtilityId: c9
router(config)#
```

**Note**

The MAC address is displayed in decimal format and must be converted into hex format.

Debugging Commands to Verify the Cell Relay

Use the following commands to verify the Cell Relay:

```
router(config)# logging level c1222r 7
router(config)# logging logfile <filename> 7
router(config)# show logging level c1222r
Facility          Default Severity      Current Session Severity
-----
c1222r            3                      7

0(emergencies)    1(alerts)             2(critical)
3(errors)         4(warnings)           5(notifications)
6(information)    7(debugging)
```

```
router(config)#
```

Use the following commands to verify the logs:

```
router(config)# show logging logfile | include ITRON
2009 Jan  4 22:06:21 Altamont37-FAR1 %C1222R-1-ITRON_SDK_LOG_ALERT: Configuration file not
found. Using defaults.
2009 Jan  4 22:06:22 Altamont37-FAR1 %C1222R-2-ITRON_SDK_LOG_CRIT: Unable to open UART
file /dev/ttyUSB0. Errno=19
2009 Jan  4 22:18:51 Altamont37-FAR1 %C1222R-4-ITRON_SDK_LOG_WARNING: TCP connection to
10.1.1.10 timed out waiting for ESTABLISHED state
```

Use `show logging logfile | last <# of lines>` to get the last number of lines in the logfile. The following is the example to get the last 10 lines in the logfile:

```
router(config)# show logging logfile | last 10
```

FIRST REVIEW DRAFT – CISCO CONFIDENTIAL**Additional Debugging Commands**

All debug commands can be enabled using the `debug c1222r` command followed by the area of interest. To find out details on the available debug command options, enter `debug c1222r ?`.

```
router(config)# debug c1222r warning
```

You can check to see if a debugging option is enabled or disabled by using `show debug`:

```
router(config)# show debug c1222r
C1222R Daemon:
  MTS Receive Packets debugging is on
  MTS Transmit Packets debugging is on
  MTS Receive Packet header/payload debugging is on
  MTS Transmit Packet header/payload debugging is on
  High Availability debugging is on
  Event debugging is on
  Error debugging is on
  Warning debugging is on
  Trace debugging is on
  Trace Detail debugging is on
  Demux debugging is on
  Dequeue debugging is on
```

Sample Router Configuration

```
router# show running-config

!Command: show running-config
!Time: Tue Oct 4 15:23:02 2011

version 5.2(1)
logging level feature-mgr 0
hostname Altamont37
vdc wireless-far id 1
  limit-resource vlan minimum 16 maximum 4094
  limit-resource vrf minimum 2 maximum 4096
  limit-resource u4route-mem minimum 9 maximum 9
  limit-resource u6route-mem minimum 24 maximum 24
  limit-resource m4route-mem minimum 58 maximum 58
  limit-resource m6route-mem minimum 8 maximum 8

feature telnet
feature crypto ike
crypto ike domain ipsec
  policy 10
    authentication pre-share
    group 5
    key Cisco123 address 11.0.0.1
    key Cisco123 address 192.10.0.1
    key Cisco123 address 192.168.168.1
feature scheduler
feature ospf
feature netflow
feature dhcp
feature tunnel
feature crypto ipsec virtual-tunnel
feature c1222r

logging level ntp 7
logging level evmc 7
```

FIRST REVIEW DRAFT – CISCO CONFIDENTIAL

```
logging level evms 7
logging level vshd 7
logging level wifipm 2
logging level netstack 3

username adminbackup password 5 ! role network-operator
username admin password 5 $1$c1xfU5Ae$auC5BarZetpQMhU4gjA5a. role network-admin
no password strength-check
ip domain-lookup
copp profile strict
snmp-server user admin network-admin auth md5 0xa4495f08940116511391f04d149fc878
  priv 0xa4495f08940116511391f04d149fc878 localizedkey
rmon event 1 log trap public description FATAL(1) owner PMON@FATAL
rmon event 2 log trap public description CRITICAL(2) owner PMON@CRITICAL
rmon event 3 log trap public description ERROR(3) owner PMON@ERROR
rmon event 4 log trap public description WARNING(4) owner PMON@WARNING
rmon event 5 log trap public description INFORMATION(5) owner PMON@INFO
ntp distribute
ntp peer 10.1.1.99
ntp source-interface Ethernet2/1
ntp commit

vrf context management
track 1 ip route 20.0.0.1/32 reachability
  delay up 120 down 120

crypto ipsec transform-set MyTransformSet esp-aes 128 esp-sha1-hmac
crypto ipsec profile MyProfile
  set transform-set MyTransformSet
vlan 1

service dhcp
ip dhcp relay
wifi ssid blah
  authentication open

interface Tunnel15
  ip address 23.0.5.2/30
  ip ospf cost 100
  ip ospf dead-interval 20
  ip ospf hello-interval 5
  ip ospf mtu-ignore
  ip router ospf 2 area 0.0.0.2
  tunnel mode ipsec ipv4
  tunnel source wimax5/1
  tunnel destination 192.10.0.1
  no keepalive
  tunnel protection ipsec profile MyProfile
  no shutdown

interface Tunnel16
  ip address 23.0.6.2/30
  ip ospf cost 500
  ip ospf dead-interval 20
  ip ospf hello-interval 5
  ip ospf mtu-ignore
  ip router ospf 2 area 0.0.0.2
  tunnel mode ipsec ipv4
  tunnel source cellular3/1
  tunnel destination 192.168.168.1
  no keepalive
  tunnel protection ipsec profile MyProfile
  no shutdown
```

FIRST REVIEW DRAFT – CISCO CONFIDENTIAL

```
interface Tunnel17
  ip address 23.0.7.2/30
  ip ospf cost 1000
  ip ospf dead-interval 20
  ip ospf hello-interval 5
  ip ospf mtu-ignore
  ip router ospf 2 area 0.0.0.2
  tunnel mode ipsec ipv4
  tunnel source Ethernet2/7
  tunnel destination 11.0.0.1
  no keepalive
  tunnel protection ipsec profile MyProfile
  no shutdown

interface Tunnel111
  ip address 2.2.2.2/24
  ipv6 address 2001:a:a:abcd::2/64
  tunnel source Ethernet2/7
  tunnel destination 11.0.0.1
  no keepalive

interface dialer1
  dialer persistent
  dialer pool 1
  dialer string gsm1

interface Ethernet2/1
  mac-address 0022.bde0.2f91
  ip address 172.27.166.60/8
  no shutdown

interface Ethernet2/2
  mac-address 0022.bde0.2f92
  no shutdown

interface Ethernet2/3
  mac-address 0022.bde0.2f93

interface Ethernet2/4
  mac-address 0022.bde0.2f94
  ip address dhcp
  no shutdown
  ip dhcp relay address 19.0.0.100

interface Ethernet2/5
  mac-address 0022.bde0.2f95

interface Ethernet2/6
  mac-address 0022.bde0.2f96
  ipv6 address 80::1/64
  no shutdown

interface Ethernet2/7
  ip address 11.0.0.11/16
  no shutdown

interface Ethernet2/8
  mac-address 0022.bde0.2f98

interface loopback0
  ip address 20.0.0.2/24
  ip router ospf 2 area 0.0.0.2

interface loopback5
```

FIRST REVIEW DRAFT – CISCO CONFIDENTIAL

```

interface cellular3/1
  no shutdown
  dialer pool-member 1

interface wimax5/1
  no shutdown
  scan-list aaa
  ip address 192.10.0.21/16

interface wpan4/1
  panid 0

interface wifi2/1
  clock timezone PST -8 0
  clock summer-time PDT 2 Sun Mar 02:00 1 Sun Nov 02:00 60
  line console
    exec-timeout 0
  line vty
    exec-timeout 0
  router ospf 2
  ip route 10.1.1.0/24 20.0.0.1
  ip route 128.0.0.0/8 172.27.166.1
  ip route 171.0.0.0/8 172.27.166.1
  ip route 172.0.0.0/8 172.27.166.1
  ip route 182.0.0.0/8 25.0.0.1
  ipv6 route 2001:a:a:abcd::/127 Tunnel111
  event manager environment bh_iflist2 "tunnel1 tunnel15 tunnel16"
  event manager environment bh_down_reset_thresh "30"
  event manager environment bh_iflist "cell3/1 wimax5/1"
  event manager environment bh_down_reload_thresh "60"
  event manager environment bh_flap_thresh_cnt "10"
  event manager environment bh_flap_thresh_duration "15"
  event manager environment bhmgr_track_obj_instance "1"
  event manager environment eem_dbg_level "1"
  event manager applet bhmgrbhdwn
    event track 1 state down
    action 1.0 syslog priority critical msg Backhaul is down
    action 2.0 cli tclsh bootflash:bhmgr.tcl bhmgr_process_bh_down
    action 3.0 cli command maximum-timeout
  event manager applet bhmgrbhup
    event track 1 state up
    action 1.0 syslog priority errors msg Backhaul is up
    action 2.0 cli tclsh bootflash:bhmgr.tcl bhmgr_process_bh_up
    action 3.0 cli command maximum-timeout
  event manager applet shutnoshutif
    event track 15 state down
    action 1.0 syslog priority critical msg Wimax went down - doing shut/no shut o

chat-script gsm1 PROFILE1
wimax scan-list aaa
  channel index 1 frequency 2550000 bandwidth 10000
  nap id 00:00:01 priority 1 channel-index 1
  nsp id 00:00:01 home

cgdm
logging logfile test 7
logging monitor 7
logging level user 2

scheduler job name bhmgr_monitor
tclsh bootflash:/bhmgr.tcl bhmgr_monitor

```

FIRST REVIEW DRAFT – CISCO CONFIDENTIAL

```
end-job

scheduler schedule name bhmgr_monitor_schedule
  job name bhmgr_monitor
  time start 2011:08:30:16:09 repeat 0:0:1

router#
```

Additional References

Consult the following resources for related information about the Connected Grid WPAN Module for technical assistance.

Hardware Overview and Installation

- *Cisco Connected Grid Modules*
http://www.cisco.com/en/US/products/ps10984/prod_module_series_home.html
- *Cisco CGR 1240 Hardware Installation Guide*
- *Cisco CGR 1120 Hardware Installation Guide*
- *Cisco CGS1240 Getting Started Guide*

Supported Cisco Antennas and Accessories

- *Cisco 3G Omnidirectional Outdoor Antenna (3G-ANTM-OUT-OM)*
<http://www.cisco.com/en/US/docs/routers/access/wireless/hardware/notes/ant3gom.html>
- *Cisco Multiband Omnidirectional Panel-Mount Antenna (3G-ANTM-OUT-LP)*
<http://www.cisco.com/en/US/docs/routers/access/wireless/hardware/notes/antcmLP.html>

Cisco System Software Commands

- *Cisco System Software*
http://www.cisco.com/en/US/products/ps9372/tsd_products_support_series_home.html
- *Configuring Cisco EHWIC-3G-EDVO-x*
http://www.cisco.com/en/US/docs/routers/access/1800/1861/software/feature/guide/mrwlsv_evdoh.html
- *Cisco 1000 Series Connected Grid Routers Unicast Routing Software Configuration Guide*

Regulatory, Compliance, and Safety Information

- *Cisco Network Modules and Interface Cards Regulatory Compliance and Safety Information*
<http://www.cisco.com/en/US/docs/routers/access/interfaces/rcsi/IOHrcsi.html>

Technical Assistance

The Cisco Support and Documentation website provides online resources to download documentation, software, and tools. Use these resources to install and configure the software and to troubleshoot and resolve technical issues with Cisco products and technologies. Access to most tools on the Cisco Support and Documentation website requires a Cisco.com user ID and password.

<http://www.cisco.com/cisco/web/support/index.html>

Cisco and the Cisco Logo are trademarks of Cisco Systems, Inc. and/or its affiliates in the U.S. and other countries. A listing of Cisco's trademarks can be found at www.cisco.com/go/trademarks. Third party trademarks mentioned are the property of their respective owners. The use of the word partner does not imply a partnership relationship between Cisco and any other company. (1005R)

Any Internet Protocol (IP) addresses and phone numbers used in this document are not intended to be actual addresses and phone numbers. Any examples, command display output, network topology diagrams, and other figures included in the document are shown for illustrative purposes only. Any use of actual IP addresses or phone numbers in illustrative content is unintentional and coincidental.

© 2011 Cisco Systems, Inc. All rights reserved.