



CITROËN C4 Handbook





CITROËN and TOTAL

A partnership of expertise



For 39 years, the research teams of CITROËN and TOTAL have combined their know-how to offer you the best engine/lubricant combination available. Cutting edge technology for your benefit. With TOTAL, you can be sure to have chosen the benchmark oil that best guarantees your CITROËN's performance and life-expectancy.

A partnership for the environment



TOTAL oils support CITROËN's advances in fuel economy, and CO₂ and harmful emission reductions.

The development of new generation oils specially adapted for Particle Filters, like TOTAL ACTIVA/QUARTZ INEO ECS can reduce CO₂ emissions by a tonne* and save a tank of fuel each year**.

* Official CO₂ emissions reduction of 4 g per km (approx. 6 g per mile). Corresponds to a reduction in CO₂ emissions of 1 tonne throughout the life of the vehicle, on a private diesel vehicle with an average life expectancy estimated at 250 000 km (approx. 160 000 miles). Source: TOTAL.

** Or 30 L, average quantity of fuel required to fill a tank at a petrol station. Result obtained using TOTAL ACTIVA/QUARTZ INEO ECS oil instead of a traditional 15W-40 oil, on a CITROËN C4 1.6 HDi, whose average fuel consumption is 58.9 mpg (4.8 L/100 km), travelling 18 000 km (approx. 12 000 miles) per year. Source: TOTAL.

A partnership of success

Competitive successes in the national rallies of the World Rally Championship bear testament to the performance and efficiency of the CITROËN – TOTAL partnership.



CITROËN

CITROËN prefers TOTAL





This handbook is compiled on the basis of all the equipment that is available (whether standard or optional) and of the technical specifications that were known at the time of going to print.

The level of equipment on your vehicle depends on the model, the options chosen and the country where the vehicle is marketed.

Some of the equipment mentioned in this handbook may only be available at a later date.

Descriptions and illustrations are given without obligation.

Automobiles CITROËN reserves the right to modify its models and their equipment without necessarily being bound to update the present handbook.

The trained professional staff of the CITROËN network are at your disposal to answer any questions you may have.

We wish you safe and enjoyable motoring in your new CITROËN.

**This handbook is an integral part of your CITROËN.
It should be kept in the vehicle where it can be
consulted easily.
Do not forget to pass it on to the new owner
if you should sell the vehicle.**



Création 4Dconcept - Automobiles CITROËN - RCS PARIS 642 050 199 - Imp. en UE

6.2 07-08 Anglais





GB. 08C4. 0031

Anglais





We thank you for choosing to drive a new CITROËN
and we congratulate you on your choice.

Please read this handbook carefully before taking to the road.

It contains essential information about driving your vehicle and operating its equipment, as well as other important advice to be rigorously followed.

The handbook also contains all you need to know about the servicing and routine maintenance of your vehicle, thus assuring both your safety and the reliability of your new CITROËN.

A thorough knowledge of your new CITROËN
will enable you to enjoy driving to the full.

Depending on the version of your vehicle and its options, as well as on the date of manufacture and the country of marketing, some of the equipment or certain functions described in this handbook may not be present on your vehicle.



Please note the following point:

The fitting of electrical equipment or accessories that are not recommended by CITROËN may result in a failure of your vehicle's electronic system. Please note this specific warning. It is advisable to contact a CITROËN dealer to be shown the recommended equipment and accessories.





FAMILIARISATION 4 → 22

I - OPERATING CONTROLS 23 → 30

■ Instrument panel	23
■ Warning lamps	24
■ Particle filter (Diesel)	26
■ Maintenance indicator	27
■ Engine oil level indicator	29
■ Display lighting rheostat	29

III - COMFORT 41 → 56

■ Air distribution	41
■ Ventilation/Ventilation	43
■ Automatic air conditioning	45
■ Scented air freshener	48
■ Front seats	49
■ Rear seats	53
■ Rear view mirrors	55
■ Steering column adjustment	56

V - VISIBILITY 65 → 72

■ Lighting control	65
■ Headlamp adjustment	66
■ Direction indicators	67
■ Hazard warning lamps	67
■ Directional headlamps	68
■ Wiper controls	69
■ Interior lighting	71

II - MULTIFUNCTION DISPLAYS 31 → 40

■ Display A	31
■ Display C	34
■ NaviDrive Display	37
■ Trip computer	38

IV - ACCESS 57 → 64

■ Keys	57
■ Remote control	58
■ Alarm	60
■ Electric windows	62
■ Child safety	63
■ Doors	63
■ Tailgate	64

VI - INTERIOR COMFORT 73 → 77

■ Interior	73
■ Boot	77

VII - CHILD SAFETY 78 → 83

■ General	78
■ Child seats	79
■ Isofix mountings	81





VIII - SAFETY 84 → 96

■ Tyre pressure sensors	84
■ Braking assistance systems (ABS)	85
■ Trajectory control systems (ESP/ASR)	86
■ Seat belts	87
■ Airbags	90
■ Safety advice	94
■ Lane departure warning system	96

X - MAINTENANCE 116 → 123

■ Bonnet release	116
■ Petrol engines	117
■ Diesel engines	118
■ Levels	119

XII - TECHNICAL SPECIFICATIONS 151 → 162

■ Capacities	151
■ Weights	152
■ Fuel consumption	157
■ Dimensions	160
■ Vehicle identification	162

IX - DRIVING 97 → 115

■ Handbrake	97
■ Manual gearbox	99
■ Electronic gearbox system (EGS) - 6 speed	100
■ Hill start assist	105
■ Automatic gearbox	106
■ Cruise control	110
■ Speed limiter	112

XI - PRACTICAL ADVICE 124 → 150

■ Refuelling	124
■ Changing a wheel	125
■ Replacing bulbs	129
■ Replacing a fuse	136
■ Battery	142
■ Towing	145
■ Towing a trailer	147
■ Cold weather shield	148
■ Accessories	149

XIII - RADIO 163 → 179

■ Radio-RDS-CD	163
■ CD changer	173
■ Hands-free telephone	174
■ Frequently asked questions	178

INDEX 180 → 183



EXTERIOR

Directional headlamps

This lighting function automatically improves forward vision when cornering.

»» 68

Visual and audible parking assistance, front/rear

This system warns you if an obstacle is detected when manoeuvring the vehicle.

»» 114



Guide-me-home lighting

The headlamps stay on for a short period after switching off the ignition.

»» 65

Lane departure warning system

Above 50 mph, this system is activated automatically if you inadvertently wander from your lane.

»» 96



OPENING

Remote control



- A. Unfolding/folding the key.
- B. Unlocking the vehicle.
- C. Locking the vehicle.



- D. Activating/deactivating guide-me-home lighting.

Manual central locking



Press once to lock the vehicle.
Press again to unlock the vehicle.

In addition...

A long press on button **C** locks the vehicle and closes the windows.

Two successive presses on button **C** deadlocks the vehicle.

» 57

» 59

» 63



OPENING

Fuel tank



A. Opening the fuel filler flap.

To open the fuel filler flap, pull at its notched edge. There is a fuel label on the inside of the flap.

Locking filler cap

Turn the key a quarter turn to lock and unlock the filler cap.

When refuelling, place the cap on the carrier on the inside face of the filler flap.

B. Removing the filler cap.

Fuel tank capacity: 60 litres approximately.

» 124

Tailgate



Unlock the vehicle with the remote control or the key.
Press up on the lever and lift the tailgate.

» 64

Spare wheel and tools



Access to the spare wheel

Lift the carpet, then remove the tool holder to gain access to the wheel.

Access to the tools

The tools are located in a protective holder in the spare wheel.

If your spare wheel is of different dimensions to the wheels on the vehicle, it is essential to use it only on a temporary basis, and to not drive above 80 km/h (50 mph).

» 125



INTERIOR

Translucent instrument panel

This system gives optimum contrast, whatever the external light level.

» 23

Scented air freshener

The air freshener distributes scented air throughout the cabin. It is located in the centre air vent

» 48

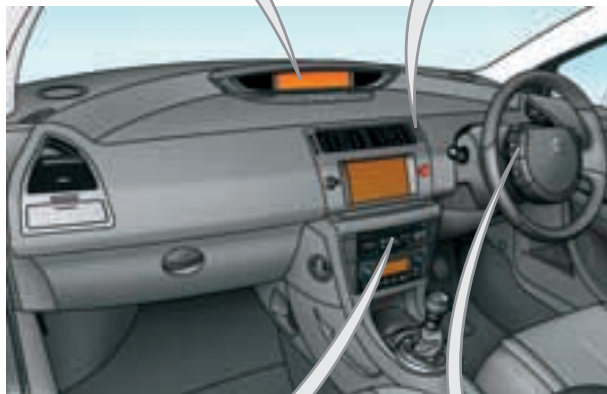

Audio and communication systems

These systems make use of the latest technologies: MP3-compatible audio, Bluetooth® hands-free kit, GPS mobile phone.

» 163

Cruise control/Speed limiter

These two systems allow the vehicle's speed to be maintained at a programmed level.

» 110, 112



DASHBOARD



1. Controls:
 - Mirrors.
 - Windows.
 - Child safety
2. Headlamp adjustment.
3. Controls:
 - ESP.
 - Parking assistance.
 - Lane departure warning system.
 - Anti-intrusion alarm.
4. Steering lock and ignition switch.
5. Controls:
 - Windscreen wiper.
 - Screen wash.
 - Rear screen wiper.
 - Trip computer.
6. Fixed centred controls.
7. Direction indicator warning lamps.
8. Speed indicator.
9. Controls:
 - Trip mileage recorder reset button.
 - Display lighting rheostat.
 - Display of alerts and status of functions.
10. Centre air vents.
11. Driver's airbag.
12. Horn.
13. Gear lever.
14. Handbrake.



DASHBOARD



1. Bonnet release.
2. Fusebox cover.
3. Storage drawer (left and right).
4. Lateral air vent (left and right).
5. Side window demister vent (left and right).
6. Loudspeaker (Tweeter) (left and right).
7. Passenger's airbag.
8. Control for central locking of doors and boot.
9. Multifunction display.
10. Hazard lamps control.
11. Scented air freshener.
12. Controls:
 - Lighting.
 - Direction indicators.
 - Front fog lamps
 - Rear fog lamps.
13. Steering column adjustment lever.
14. Radio-CD or NaviDrive radio navigation.
15. Air conditioning or heating/ventilation.
16. Cigar lighter.
17. 12-volt accessory socket (150 W max).
or
USB socket.
18. Ashtray.
19. Carrier bag hook.
20. Key-operated switch:
 - Passenger's airbag activation/
deactivation.
21. Lower glovebox.
 - Handbook pack storage.





FIXED CENTRED CONTROLS STEERING WHEEL

Controls for speed limiter and cruise control

Audio system controls

Warning lamps:
lighting and direction indicators

Function controls:

- Display lighting rheostat
- Voice recognition
- Air recirculation
- Telephone
- Personal button

Horn

Multifunction display controls





FIXED CENTRED CONTROLS STEERING WHEEL

Controls for speed limiter and cruise control

Audio system controls See "Audio" or your Navidrive instructions

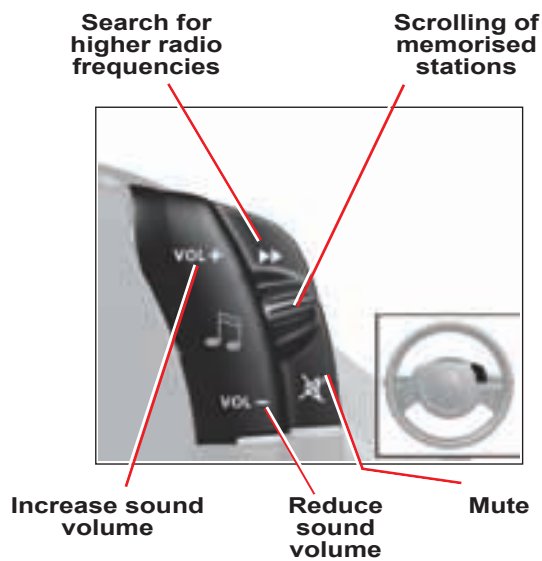
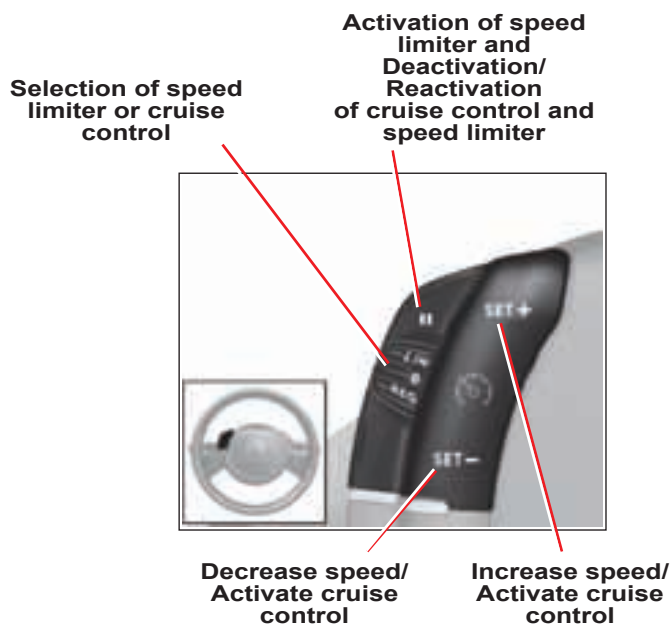

FIXED CENTRED CONTROLS STEERING WHEEL



Starting voice recognition
(See "Audio" or your Navidrive instructions)

Display lighting rheostat

Air recirculation



Telephone pick-up/hang-up
(See "Audio" or your Navidrive instructions)

Display the "Directory" menu
(See "Audio" or your Navidrive instructions)

Personal button:

- Black panel (default function), or
- Interior lamp on/off, or
- Log of alerts, or
- Status of functions

Give a long press on this button to display the personalisation menu.

Validation of the function selected or the value modified
Pick up/hang up
(See "Audio" or your Navigation instructions)

Access to "Main menu"*

Scrolling in the multifunction display



Selection of the type of information displayed on the right of the screen (radio, trip computer, navigation/guidance...) and for screen A, choice of activation/deactivation of your functions and choice of your adjustments

Cancel the current operation or return to the previous screen

* In compliance with national legislation, in some countries the "menu" control is deactivated when driving.





SITTING COMFORTABLY

Front seats

Manual adjustments



Forwards-backwards

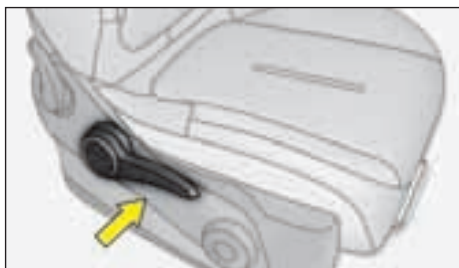

Driver's seat cushion height and angle adjustment

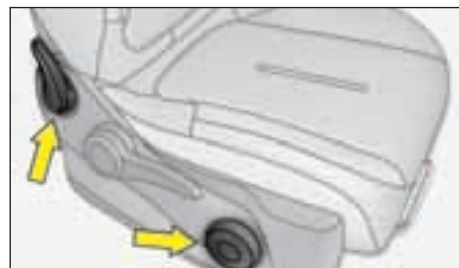

Seat back angle and lumbar adjustment

» 50

Electrically operated adjustments (driver's seat only)



Forwards-backwards



Seat cushion height and angle adjustment



Seat back angle and lumbar adjustment

» 51



SITTING COMFORTABLY

Adjustment of front head restraints



Height and angle.

» 50

Adjustment of rear head restraints



A. Low position.
B. High position.

» 53

Manual adjustment of steering wheel height and reach

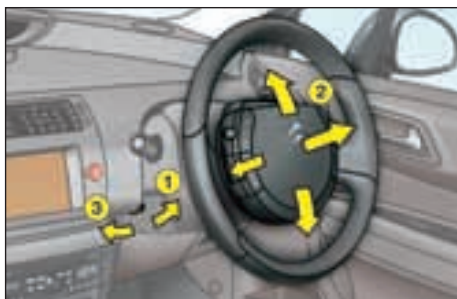

1. Unlock the steering column using the lever.
2. Adjust the position of the steering wheel for height and reach.
3. Lock the steering column with the lever.

» 56

Front seat belt



1. Locking.

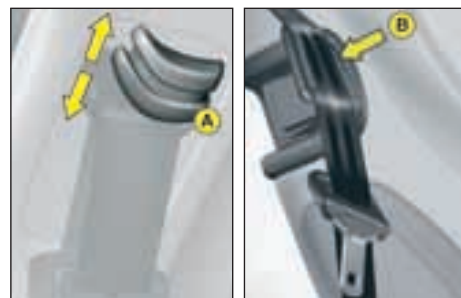

A. Height adjustment (5-door)
B. Holding the seat belt (3-door)

» 87



SITTING COMFORTABLY

Adjustment of exterior rear view mirrors



- A. Select the mirror.
- B. Adjust the mirror.
- C. Fold-back/Unfolding.

» 55

Adjustment of interior rear view mirror



- 1. Mirror direction.
- 2. Selection of the mirror's "day" position.

» 56

Electric windows



- 1. Driver's window control.
- 2. Passenger's window control.
- 3. Left hand rear window control.
- 4. Right hand rear window control.

Child safety

- 5. Inhibition of the opening of the passenger rear doors and electric windows.

» 62



VISIBILITY

Lighting



Ring A



Lighting off.



Automatic lighting.



Sidelamps.



Dipped or main beam.

Ring B



Front foglamps and rear foglamps.

» 65

Screen wipe

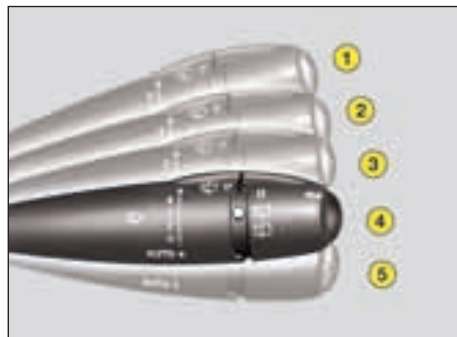

Windscreen wipe

- 2 Fast speed.
- 1 Normal speed.
- I Intermittent.
- 0 Off.
- AUTO** Automatic wipe or single wipe.

Deactivation of automatic wipe

Go to position I then return to position 0.

» 69



Rear screen wipe



Off.



Intermittent.



Timed wipe and wash.

» 70



GOOD VENTILATION

To obtain the best from the system, we advise:

I would like ...	Heating or manual Air Conditioning				
	Air distribution	Air flow	Air recirculation/ Fresh air intake	Temperature	A/C
HEATING					—
COOLING					ON
DEMISTING DEFROSTING					ON



MONITORING



Instrument panel

- A. Speedometer.
- B. Rev counter.
- C. Fuel gauge.
- D. Lighting rheostat.
- E. Warning lamp.

» 23

Warning lamps

Ignition on, the orange and red alert warning lamps come on.
 With the engine running, these same warning lamps should go out.
 If a warning lamp stays on, refer to the relevant page.

» 24

Controls

- A. Deactivation of the ESP/ASR system. » 86
- B. Deactivation of the visual and audible parking assistance. » 114
- C. Deactivation of the lane departure warning system. » 96
- D. Deactivation of the alarm volumetric sensors. » 61



PASSENGER SAFETY

Activation/Deactivation of the front passenger's airbag







- A. Insert the ignition key.
- B. Select the "ON" or "OFF" position.
- C. Remove the key.

» 92

Warnings for seat belts unfastened/not fastened



-  Driver
-  Front passenger.
-  Left rear passenger.
-  Centre rear passenger.
-  Right rear passenger.

» 25

Child safety



- A. Manual control.
- B. Electric control.

» 83



DRIVING

Ignition switch



- **S: Steering lock**
To free the steering, turn the steering wheel slightly at the same time as turning the key, avoiding any undue force.
- **M: Ignition**
- **D: Starter**
Release the key as soon as the engine has started. Never turn to this position when the engine is running.

Cruise control

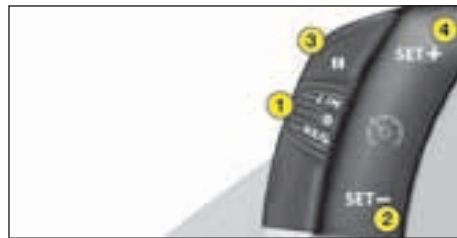

1. Selecting/stopping the cruise control mode.
2. Setting a cruising speed/Reducing the value memorised.
3. Stopping/Resuming cruise control.
4. Setting a cruising speed/Increasing the value memorised.

To be memorised or activated, the speed of the vehicle must be above 40 km/h (25 mph), with fourth or higher gear selected on a manual gearbox (second in the case of 6-speed EGS or automatic gearbox).

Speed limiter

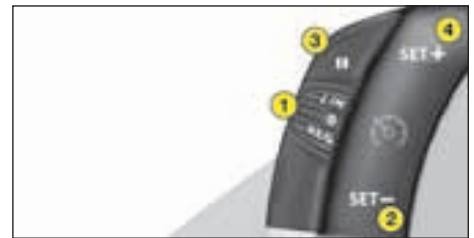

1. Selecting/Stopping the speed limiter mode.
2. Reducing the value memorised.
3. Starting/Stopping speed limitation.
4. Increasing the value memorised.

» 110

» 112



DRIVING

6-speed Electronic Gearbox System

A Automatic mode



The gearbox operates in auto-active mode without input on your part.

M Manual mode



Or

R Reverse

N Neutral

Do not select this position, even momentarily, when the vehicle is moving.

S Sport setting

Using the lever

Push the lever forwards to change up.
Pull the lever backwards to change down.

Using the control paddles behind the steering wheel

Press the "+" or "-" control paddle behind the steering wheel for an immediate gear change up or down respectively.

Under heavy acceleration, a higher gear will only be engaged if the driver operates the gear lever or the controls on the steering wheel.

» 100





DRIVING

Hill start assist (6-speed Electronic Gearbox System)

To aid starting on a gradient, your vehicle is equipped with a system that keeps it temporarily immobilised.



On a rising gradient, with the vehicle stationary, the vehicle is held for a brief moment after releasing the brake pedal, if you are in **A** or **M**.



On a falling gradient, with the vehicle stationary and reverse gear engaged, the vehicle is held for a brief moment after releasing the brake pedal.





DASHBOARD

INSTRUMENT PANEL

On opening the driver's door or unlocking with the remote control, for approximately 30 seconds the instrument panel is activated, displaying the mileage recorders and if applicable, the maintenance indicator spanner.

Central display

- | | | | |
|---|--|---|------------------------|
| 1 | Rev counter | 5 | Trip mileage recorder |
| 2 | Cruise control or speed limiter settings | 6 | Fuel gauge |
| 3 | Speedometer | 7 | Engine oil level check |
| 4 | Maintenance indicator on switching on, then mileage recorder | 8 | Coolant temperature |

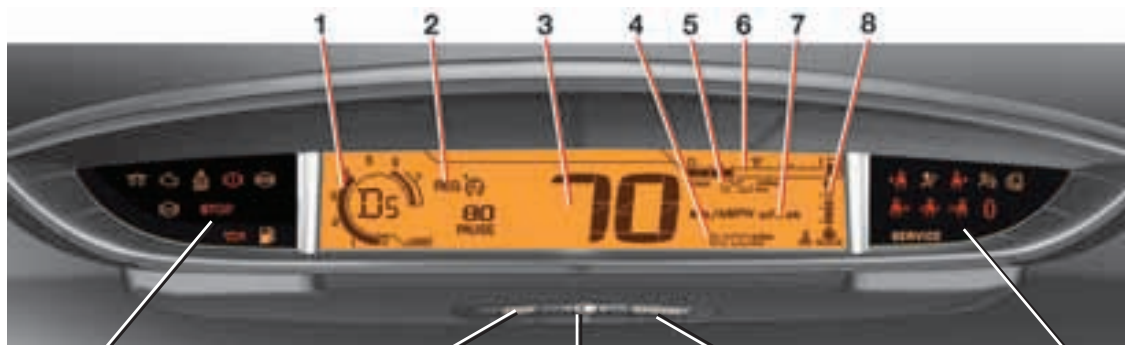

Display of warning lamps

Trip mileage recorder reset button

Display lighting rheostat

Display of alerts and Status of functions

Display of warning lamps





DASHBOARD

WARNING LAMPS



Lighting and signalling lamps
See "Visibility".



LH direction indicator



RH direction indicator

The direction indicator lamps all operate simultaneously when the hazard warning is on.



Foglamps (rear)



Foglamps (front)



Sidelamps



Dipped beam

If this warning lamp flashes, it is indicating a malfunctioning of the directional headlamps.

Contact a CITROËN dealer.



Main beam

Alert warning lamps



Imperative stop warning lamp

When the warning lamp comes on, it is imperative to stop the vehicle and switch off the engine.

Contact a CITROËN dealer.



Warning lamp for handbrake, brake fluid level and braking distribution fault

When the engine is running, this warning lamp indicates that the handbrake is applied or incompletely released, that the brake fluid level is insufficient, or that the braking system is malfunctioning.

If the warning lamp remains lit when the handbrake is released, stop immediately and contact a CITROËN Dealer (See "Safety").





DASHBOARD



Driver's seat belt not fastened

This lamp comes on if the driver's seat belt is not fastened when the ignition is switched on and while the vehicle is moving at up to 20 km/h (approx. 12 mph)

Above 20 km/h (12 mph), the warning lamp flashes for about 120 seconds, accompanied by an audible signal.



Passenger seat belt not fastened/unfastened

On switching on the ignition, the warning lamp comes on when the passenger's seat belt is not fastened.

It goes out when the engine is running, doors closed, after 30 seconds.

Then it comes on, if the belt is not fastened, while the vehicle is moving at up to 20 km/h (approx. 12 mph).

Above 20 km/h (12 mph), the warning lamp flashes for about 120 seconds, accompanied by an audible signal.



Doors open detection

This warning lamp, when the engine is running, comes on if a door, the bonnet and/or the boot is open.



Front passenger's airbag deactivation warning lamp

(See "Safety").



Front/side airbag fault warning lamp

(See "Safety").



Anti-lock Braking System

The ABS warning lamp lights when the ignition is switched on and should go out after a few seconds.

If the warning lamp does not go out, there may be a system malfunction.



Diesel Preheater

Wait for it to go out before operating the starter.



SERVICE warning lamp

If it comes on, this indicates a fault with one of the systems that do not have a specific warning lamp.

See the radio "Log of alerts" to discover the origin of the corresponding alert message.



Depollution system warning lamp

If it flashes or lights up while you are driving, this indicates a depollution system operating fault.

Urgently consult a CITROËN Dealer.



Child safety warning lamp

If child safety is activated, this warning lamp comes on then goes out approximately 10 seconds after starting the engine.





DASHBOARD

I



ESP/ASR warning lamp In operation

When either the ESP or ASR system is brought into operation, the **ESP/ASR** warning lamp flashes.

In the event of a problem

When the vehicle is moving, the lighting of the **ESP/ASR** warning lamp indicates that the system is malfunctioning.

Contact a CITROËN dealer.

Deactivation

Illumination of the **ESP/ASR** warning lamp and of the ESP control, means that the system is deactivated.



Fuel gauge and low fuel warning

When the tank is full, all the indicator bars are illuminated.

When the low fuel level warning comes on, there remain around 7 litres of fuel in the tank and 2 or 3 bars of the gauge will flash.

If the last bar disappears, there are only around 2 litres of fuel in the tank.



"Foot-on-brake" starting warning lamp for (6 speed) Electronic Gearbox System

During the engine starting phase, this flashes if you are not pressing the brake pedal.

See "(6 speed) Electronic Gearbox System".

This warning lamp may flash in the instrument panel to remind you to apply the brake when engaging reverse gear.

DIESEL PARTICULATE FILTER SYSTEM

Complementary to the catalytic converter, this filter makes an active contribution to the preservation of air quality by the retaining of the unburnt pollutant particles. Black exhaust fumes are thus no longer emitted.

Clogging of the particle filter



The **SERVICE** warning lamp and a message in the instrument panel are displayed indicating that the particulate filter is starting to become clogged (exceptionally prolonged urban driving conditions: reduced speed, traffic congestion...).

To regenerate the filter, you are advised to drive, as soon as traffic conditions permit, at a speed of 60 km/h (40 mph) or more for at least 5 minutes (until the warning message disappears).

If this alert persists, consult a CITROËN dealer.

Observation: After prolonged idling or driving at very low speeds, you may occasionally notice water vapour being emitted from the exhaust when accelerating. This is of no consequence to the running of the vehicle or to the environment.

Diesel fuel additive level



If the additive level is low, a message appears in the multifunction screen, accompanied by an audible signal and illumination of the **SERVICE** warning lamp: it is necessary to have the additive level topped up. Contact a CITROËN dealer as soon as possible.





DASHBOARD

MAINTENANCE INDICATOR

The maintenance indicator informs you when the next service is due, in conformity with the servicing programme detailed in the vehicle's Maintenance Guide. This information is determined depending on two parameters: the mileage travelled and the time elapsed since the previous service.

Operation

When the ignition is switched on and for several seconds afterwards, the maintenance spanner symbol appears; the total mileage recorder shows how many miles remain to be travelled before the next service is due (in thousands and hundreds of miles).

For example: you have the following distance left to travel before the next service:

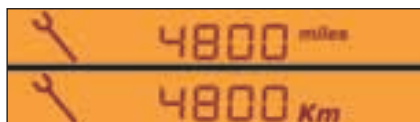

A few seconds afterwards, the total mileage display appears.

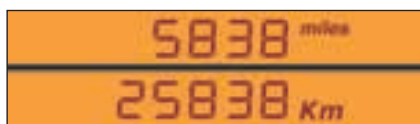

Functioning if the distance to the next service is less than 600 miles

Each time the ignition is switched on, and for five seconds, the maintenance symbol and the mileage will flash.

For example: you have the following distance left to travel before the next service: 900 km.

For five seconds on switching on the ignition, the display shows



A few seconds afterwards, the total mileage display appears and the maintenance symbol remains illuminated.

This signifies that the vehicle will be due for a service shortly.

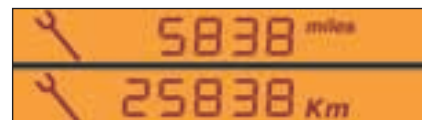

I





DASHBOARD

I Functioning if the service interval is exceeded

Each time the ignition is switched on, the maintenance symbol and the extra mileage travelled (with a minus in front) will flash.

For example: the preset service distance has been exceeded by 300 km. Your vehicle must be serviced as soon as possible.

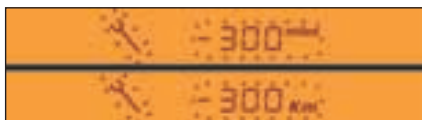

A few seconds after you have switched on the ignition, the total mileage recorder returns to its normal operation and **the maintenance symbol remains illuminated.**

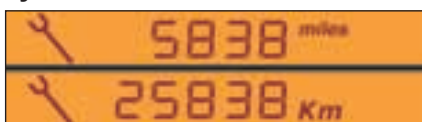

Maintenance intervals

If your vehicle is used in particularly harsh conditions, it is necessary to select the maintenance schedules for "special operating conditions" (see the Maintenance Guide) which consist of more frequent services.



Resetting the mileage indicator to zero

Your CITROËN dealer performs this operation after each service. However, if you carry out the servicing yourself, the procedure for resetting to zero is as follows:

- Switch off the ignition, then place the key on position **S**, steering lock.
- Press control **1** and keep it pressed.
- Switch on the ignition.
- Keep control **1** pressed until the zero appears and the maintenance symbol disappears.
- Switch off the ignition.





DASHBOARD

ENGINE OIL LEVEL INDICATOR

When the ignition is switched on, the oil level indicator is displayed for several seconds.

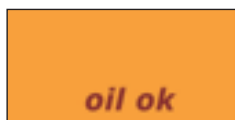

This display indicates normal operating.

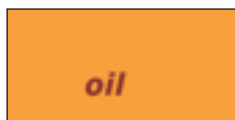

A flashing of **"OIL"** indicates an oil level that is below the minimum. Check using the manual dipstick. Check the oil level with the vehicle on horizontal ground, the engine having been switched off for at least 15 minutes.



A flashing of **"OIL --"** indicates a malfunction of the indicator. Consult your CITROËN dealer.

DASHBOARD LIGHTING RHEOSTAT



The rheostat is active if the sidelamps are on and applies to:

- the instrument panel
- the displays

The desired brightness is selected via control **A** or by pressing control **B**.

With control **B**, press until the brightness is at maximum. Release, press until you reach minimum.

I





DASHBOARD

DARK BUTTON



After the first press on control **C**, only the top part of the display remains illuminated.

A second press on control **C** triggers black panel mode.

BLACK PANEL (with headlamps on)



This function switches off certain of the displays, for night driving. It can be activated:

- either by 2 presses on control **C**
- or by 1 press on control **D** if this control has been programmed with the black panel function.

The instrument panel continues to show vehicle speed as well as the cruise control and speed limiter functions if these are activated.

If there is an alert or a modification of functions or adjustments, black panel is interrupted.

To programme control **D**:

- give a long press on control **D**,
- then select the black panel function on the multifunction screen using the arrowed buttons on your radio/CD or Navidrive system. Validate with a press on "OK".

Note: the dashboard lighting rheostat still operates in black panel mode.





MULTIFUNCTION DISPLAY

DISPLAY A



Presentation:

- 1 - Time
- 2 - Date and Display zone
- 3 - Ambient temperature

If the outside temperature is between +3 °C and -3 °C, the temperature display flashes (risk of ice).

Note: The outside temperature displayed may be higher than the actual temperature if the vehicle is standing in bright sunshine.

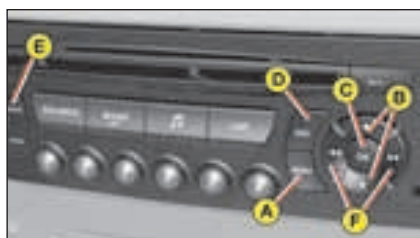

Controls:

- A** - Access to the "Main menu"
- B** - Scrolling in the display menus.
- C** - Validation and selection in the menus of the function chosen or the value modified
- D** - Cancellation of the operation or return to the previous display.
- E** - Selection of the type of information displayed in zone 2 (date, radio/CD and trip computer)
- E or F** - In the menus, choice of activation/deactivation of your functions and choice of your settings.

The driver is advised not to operate the controls when driving.





MULTIFUNCTION DISPLAY

II

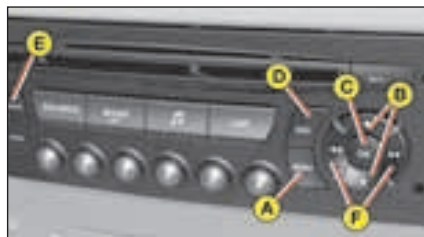

Main menu

By pressing control **A** then **B**, you have access to the following functions:

- **Radio-CD (See "Radio")**
- **Vehicle configuration**, to activate/deactivate:
 - Triggering of rear screen wipe
 - Automatic guide-me-home lighting, with choice of duration
- **Options**, to display the alerts
- **Display adjustments**, to adjust the date and time on the display
- **Languages**, to select the display language
- **Units**, to access the choices of units of Temperature and Fuel Consumption

To activate/deactivate rear screen wipe on engaging reverse gear

- Press on **A**.
- Select, using **B**, the sub-menu to personalise-configure your vehicle, then confirm your choice by a press on **C**.
- Select rear screen wipe, using **B**.
- The system tells you whether the function is active/inactive. Modify this status by a press on **E** or **F**.
- Validate with a press on **C**.

To activate/deactivate automatic guide-me-home lighting

- Press on **A**.
- Select, using **B**, the sub-menu to personalise-configure your vehicle, then confirm your choice by a press on **C**.
- Select guide-me-home lighting, using **B**.
- The system tells you whether the function is active/inactive. Modify this status by a press on **E** or **F**.
- Validate with a press on **C**.





MULTIFUNCTION DISPLAY

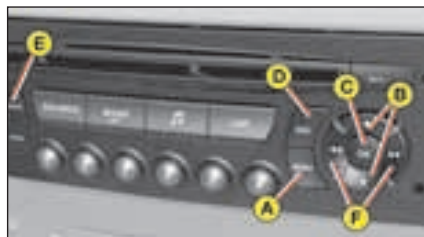

To display the log of alerts

- Press on **A**.
- Using **B**, select the sub-menu for options. Confirm with two presses on **C**.

Note: You can cancel the start of the display by selecting **E** to abandon, validate with a press on **C**.

The alerts that have previously been signalled to you but not resolved, are recalled to you in a scroll. To delete the display of an alert, press **D**.

To adjust the date and time

- Press on **A**.
- Using **B**, select the sub-menu for Display Adjustments then validate with a press on **C**.
- Using **B**, select what you wish to modify: year, month, day, hour, minutes, or display mode.
- Make your adjustment by presses on **E** or **F**. You can continue your adjustments, selecting further parameters by pressing **B**. When you have finished your adjustments, press **C**.

To choose the language

- Press on **A**.
- Using **B**, select the sub-menu for Languages. Confirm your choice with a press on **C**.
- By presses on **E** or **F**, select the language of your choice then validate with a press on **C**.

To choose the units

- Press on **A**.
- Using **B**, select the sub-menu for Units. Confirm your choice with a press on **C**.
- Using **B**, select the unit you wish to modify (Temperature or Consumption).
- Via presses on **E** or **F**, select the unit of your choice, then validate with a press on **C**.

Note: This choice concerns all the types of information (fuel consumption, speed, etc.) that appear on the displays.





MULTIFUNCTION DISPLAY

DISPLAY C



Presentation:

- 1 - Time.
- 2 - Ambient temperature
- 3 - Date and Display zone

If the outside temperature is between +3 °C and -3 °C, the temperature display flashes (risk of ice).

Note: the outside temperature displayed may be higher than the actual temperature if the vehicle is standing in bright sunlight.

The driver is advised not to operate the controls when driving.

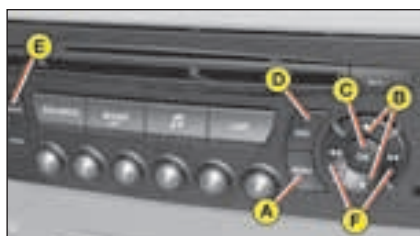

Controls

- A** - Access to the "Main menu".
- B** - Scrolling in the display menus.
- C** - Validation and selection in the menus of the function chosen or the value modified.
- D** - Cancellation of the operation or return to the previous display.
- E** - Selection of the type of information you wish to see permanently displayed (date, radio-CD, trip computer) on the right of the screen.

Main menu

Press control **A** to display the "Main menu" for the multifunction screen. Using this menu, you have access to the following functions:



Radio-CD
(See "Radio")



Bluetooth hands-free kit
(See "Radio")



Trip computer

It allows:

- Distance to your destination.
- Access to log of alerts (list of the alerts that have been previously signalled).
- Access to status of functions, for example activation/deactivation of automatic lighting of head-lamps, ESP, windscreen wipers.





MULTIFUNCTION DISPLAY



Personalisation Configuration

It allows you to activate/deactivate:

- Triggering of rear screen wipe.
- Automatic guide-me-home lighting, with choice of duration.
- Driving headlamps.

Also to choose:

- Brightness, the time, the date, units.
- The display language.

To activate/deactivate rear wipe on engaging reverse gear

- Press on **A**.
- Use **B** to select the trip computer icon, then confirm with a press on **C**.
- Select your entry of distance, using **B**. Confirm your choice with a press on **C**.
- To choose the distance, select the figure to be modified, using **B**, then confirm with a press on **C**.
- Use **B** to adjust the value then validate with a press on **C**.
- Validate on **"OK"** on the display.

To activate/deactivate automatic guide-me-home lighting

- Press on **A**.
- Use **B** to select the icon "Personalisation-Configuration" then confirm your choice with a press on **C**.
- Then select the sub-menu for vehicle parameters. Confirm your choice with a press on **C**.
- Using **B**, select lighting and signalling. Confirm your choice with a press on **C**.
- Then with a press on **C**, select/deselect guide-me-home lighting to activate or deactivate it. After activation, choose the duration: press on **C** then use **B** to select the duration and press on **C**.
- Validate on **"OK"** on the display.

To activate/deactivate the directional headlamps

- Press on **A**.
- Use **B** to select the icon "Personalisation-Configuration" then confirm your choice with a press on **C**.
- Then select the sub-menu for vehicle parameters. Confirm with a press on **C**.

- Using **B**, select the driving assistance. Confirm your choice with a press on **C**.
- Then with a press on **C**, select/deselect driving headlamps to activate or deactivate them.
- Validate on **"OK"** on the display.

To adjust the display brightness

- Press on **A**.
- Use **B** to select the icon "Personalisation-Configuration" then confirm your choice with a press on **C**.
- Select the display configuration using **B**. Confirm with a press on **C**.
- Select the adjustment of brightness. Confirm with a press on **C**.
- Use **B** to select normal or other display mode, then validate with a press on **C**. To adjust the brightness, select the symbols **"+"** or **"-"** and confirm your adjustment with a press on **C**.
- Validate on **"OK"** on the display.





MULTIFUNCTION DISPLAY

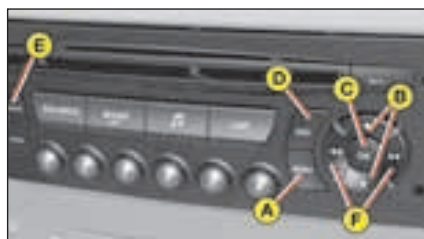
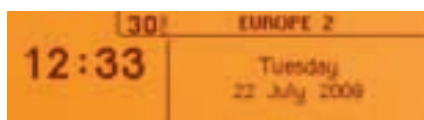

To adjust the date and time

- Press on **A**.
- Use **B** to select the icon "Personalisation-Configuration" then confirm your choice with a press on **C**.
- Select the display configuration using **B**. Confirm with a press on **C**.
- Select the date and time adjustment, using **B**, then confirm with a press on **C**.
- Use **B** to select the values to be modified. Confirm with a press on **C**.
- Make your adjustments using **B**, validating each adjustment with a press on **C**.
- Validate on "**OK**" on the display.

To choose units

- Press on **A**.
- Use **B** to select the icon "Personalisation-Configuration" then confirm your choice with a press on **C**.
- Select the display configuration using **B**. Confirm with a press on **C**.
- Then select the sub-menu for Units. Confirm with a press on **C**.
- Using **B**, select the unit to be modified (Temperature or Consumption) then validate with a press on **C**.
- Validate on "**OK**" on the display.

Note: This choice concerns all the types of information (fuel consumption, speed, etc.) that appear on the displays.

To choose the language

- Press on **A**.
- Use **B** to select the icon "Personalisation-Configuration" then confirm your choice with a press on **C**.
- Select the choice of language, using **B**.
- Using **B**, select the desired language and validate your choice with a press on **C**.
- Validate on "**OK**" on the display.





MULTIFUNCTION DISPLAY

NAVIDRIVE DISPLAY

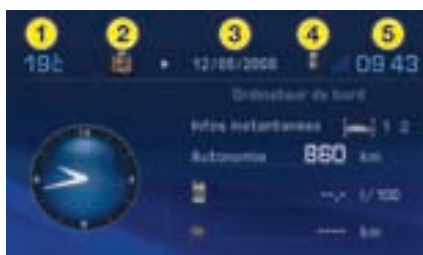

Presentation:

- 1 - Ambient temperature
- 2 - Directory
- 3 - Date
- 4 - Telephone
- 5 - Time

If the outside temperature is between +3 °C and -3 °C, the temperature display flashes (risk of ice).

Note: The outside temperature displayed may be higher than the actual temperature if the vehicle is standing in bright sunshine.

The driver is advised not to operate the controls when driving.



Controls

- A** - Access to the "Main menu".
- B** - Scrolling in the display menus.
- C** - Validation and Selection in the menus, of the function chosen or value modified.
- D** - Cancellation of the operation or return to the previous display.
- E** - Selection of the type of information you wish to see permanently displayed (date, radio-CD, trip computer) on the right of the screen.

Main menu

Press control **A** to display the "Main menu" for the multifunction screen.

This menu gives access to the following functions (See "Navidrive" instructions):



Navigation/guidance



Map



Traffic information



Audio



Audio



Configuration, for adjusting various parameters (date, time, units)



Video



Vehicle diagnosis





MULTIFUNCTION DISPLAY

TRIP COMPUTER

II



To obtain display and selection of the different types of information, give short presses on the end of the windscreen wiper stalk.

To reset trip computer information to zero, press continuously for a few seconds on the end of the stalk when one of the information types is displayed.

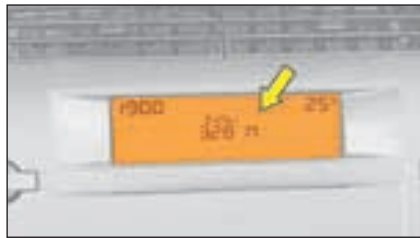

Display A

The trip computer provides 5 types of information, which can be accessed by pressing successively on the end of the control stalk.

- Range
- Instantaneous fuel consumption
- Distance travelled
- Average fuel consumption
- Average speed

To cancel the display of the trip computer information press a sixth time



Display C or NaviDrive

3 types of instantaneous information:

- Range
- Instantaneous consumption
- Distance remaining to be travelled

It also gives you access to 3 types of information for two Journeys 1 and 2:

- Distance travelled
- Average consumption
- Average speed





MULTIFUNCTION DISPLAY

Display C or NaviDrive (continued)

The journeys

Journeys 1 and 2 are identical but independent of each other. For example, you can use Journey 1 for daily calculations and Journey 2 for monthly calculations.

To reset a journey to zero

When the desired journey is displayed, give a long press on the end of the wiper stalk.

Permanent display

Pressing the "Mode" button causes the trip computer information to be displayed permanently.

Enter the distance to be travelled

- Press **A**.
- Using **B** select the trip computer icon, then validate by pressing **C**.
- Select distance entry, using **B**. Validate your choice by pressing **C**.
- To choose the distance, select the figure to be modified using **B** then validate using **C**.
- Using **B**, adjust the value then validate using **C**.
- Validate with **"OK"** in the display.

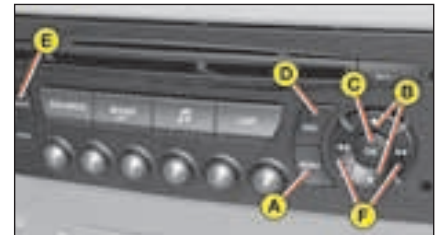

To display the log of alerts or status of functions

- Press **A**.
- Using **B** select the trip computer icon, then validate by pressing **C**.
- Select the log of alerts or status of functions.
- Once the list is displayed, scroll through the list using **B**.
- Press **D** to return to the permanent display.





MULTIFUNCTION DISPLAY

Display A

||



Range

This indicates the mileage that can still be travelled using the fuel remaining in the tank.

When the distance remaining to be travelled is less than about 25 km (approx. 15 miles), only three dashes are displayed.

After resetting the computer, the indication of remaining range is only reliable after the vehicle has been used for a certain time.



Average fuel consumption

The average fuel consumption is calculated from the last reset of the computer.



Instantaneous fuel consumption

This is calculated from consumption over the previous 2 seconds. This function is only available when travelling at over 30 km/h (approx. 20 mph).



Average speed

The average speed is obtained, from the last reset of the computer, by dividing the distance covered by the time taken (ignition on).



Distance travelled

It indicates the distance travelled since the trip computer was last reset to zero.

Distance remaining

See previous page.

Display C or NaviDrive (continued)

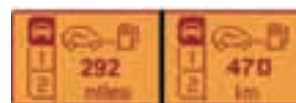

Range 292 miles

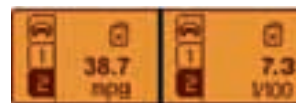

38.7 mpg



24.8 mpg



67 mph



Distance 228 miles

90 miles





COMFORT

VENTILATION



Air intake

Make sure that the exterior air inlet grille at the base of the windscreen is clean (free of dead leaves, snow etc.).

If washing the vehicle with a high pressure jet, take care to avoid targeting close to the air inlet.

Air vents

The air vents have grilles for directing the flow of air (up/down, right/left) with controls for adjusting the volume of air.

Air circulation

Optimal comfort is obtained by a good distribution of air in the front and the rear of the passenger compartment.

To ensure efficient operation, take care not to obstruct the air outlets located under the front seats.

Pollen filter/odour filter (active carbon)

Your installation has a filter for excluding dust and restricting disagreeable odours.

This filter needs to be changed according to the maintenance requirements. (See: Maintenance Guide).





COMFORT

Air conditioning

At any time of year, the air conditioning is useful for removing air humidity and misting.

To keep the air conditioning compressor well sealed, it is essential to operate the air conditioning at least once in every month.

To be effective, the air conditioning should only be used with the windows closed.

If you are towing a heavy trailer or if outside temperatures are very high, the air conditioning may be temporarily interrupted in favour of engine cooling.

Water arising from condensation in the air conditioning is allowed to drain out through an aperture provided for this purpose; a pool of water may thus form beneath the vehicle when stationary.

You are recommended to have the air conditioning system checked on a regular basis (see Maintenance Guide).

The air conditioning uses energy from the engine to operate. This results in extra fuel consumption.



Sensor

The automatic air conditioning inside the passenger compartment makes use of the sunlight sensor, which is located on the dashboard behind the instrument panel.

Take care not to obstruct it.





COMFORT

HEATING/VENTILATION



MANUAL AIR CONDITIONING



The heating/ventilation and manual air conditioning systems can only function with the engine running.

1 - Adjustment of the air distribution



Demisting - Defrosting.
Flow to the windscreen and front side windows.



Distribution to the windscreen, side windows and footwells.



Flow to front and rear passenger footwells.



Air flow to the face level vents.

Distribution from the air blower can be altered at will by placing the distributor **1** in an intermediate position.

2 - Air recirculation



This position is for excluding disagreeable odours or emissions coming from outside the cabin. With a press on control **2**, the entry of air from outside is closed off, the lamp comes on.

This should be cancelled as soon as possible to prevent misting and to allow fresh air into the cabin.

To deactivate air recirculation, press again on control **2**, the warning lamp goes out.

3 - Heater blower control

The air blower operates only when the engine is running. For optimum comfort in the passenger compartment, the control should not remain in position **0** (position **1** minimum).

4 - Temperature control





COMFORT

5 - Rear screen demisting

Can only be operated with the engine running.



One press on control **5** activates the electric demisting of the rear screen and, according to version, the exterior rear view mirrors. The warning lamp comes on.

It switches off automatically to avoid excessive consumption of power.

One press stops the demisting.

A further press starts it again.

Note: If the engine is stopped before the end of demisting, the latter will resume the next time the engine is started.

6 - Air conditioning

The air conditioning will only operate when the engine is running.



Press on control **6**. The warning lamp comes on.

For air conditioning, the air blower control **3** must not be on position "0".

Air conditioning is obtained by mixing the warm air with refrigerated air. The control for the blown air temperature **4** adjusts the air conditioning provided the control **6** is operational.



Demisting-deicing of the windscreen and front side windows

- Place the controls for temperature and air flow on maximum.
- Close the central air vents.
- Operate the air conditioning by pressing the control **6**, the warning lamp comes on.

Note: you should not be in air recirculation.





COMFORT

AUTOMATIC AIR CONDITIONING



This system automatically regulates temperature, air flow and air distribution in the passenger compartment according to the temperature selected (for each side, right and left).

It provides an optimum level of comfort regardless of the climatic conditions, **by permanent use** of the automatic air conditioning mode (press the **AUTO** button) and with **all the vents open**.

Having no airflow prevents the air conditioning and the system in general from working.

1 - Automatic operation



This is the normal operating mode.



A press on this control, confirmed by the display of "**A/C**" and "**AUTO**", automatically manages all the 5 following functions according to the temperature chosen:

- Flow of air.
- Cabin temperature.
- Distribution of air.
- Air conditioning.
- Recycling of air.

To enable the system to operate, all the air vents should be kept open.

2 - Adjustment of temperature on left hand side



3 - Adjustment of temperature on right hand side



To display the desired temperature, rotate control 2 or 3:

- To the left to lower the temperature
- To the right to raise the temperature

The difference between the temperatures on the right and on the left cannot be greater than 3.

An adjustment around 21 will provide a temperature that is comfortable. Depending on your requirements, an adjustment between 18 and 24 is normal.



The display **HI** (high) corresponds to a demand for maximum heating (above 27).



The display **LO** (low) corresponds to a demand for maximum air conditioning (below 15).

To prevent misting of the interior of the vehicle in cold and damp conditions, the use of AUTO mode is recommended.





COMFORT

Notes:

- When you enter the vehicle, the temperature inside the vehicle may be much colder (or warmer) than a comfortable temperature. It is no use modifying the displayed temperature to try to attain the desired level of comfort. The system automatically strives to compensate this temperature discrepancy as rapidly as possible.
- When starting the engine from cold, in order to avoid distributing too much cold air, the blower will attain its optimum level gradually.

Manual recalling of one or more functions

All the functions 4, 6 and 7 can be adjusted manually.

Display of the function "AUTO" then disappears.

4 - Air conditioning



To stop the air conditioning, press on the control 4. The symbol "A/C" disappears.

To restart it, press again on the control 4. The symbol "A/C" displays.

5 - Air recirculation



When you press on control 5, the entry of air from outside is blocked off and the associated symbol is displayed.

This function can also be accessed by pressing the appropriate button on the steering wheel.

While retaining the other settings, this position excludes disagreeable odours or emissions coming from outside. It should be cancelled as soon as possible to prevent misting and to allow fresh air into the cabin.

To deactivate the air recirculation, press again on control 5.

6 - Adjustment of the air distribution



Press the button successively so that the display shows, in turn, the air flow to:



The windscreen and front side windows.



The windscreen, front side windows and passenger footwells.



Passenger footwells.



Central and lateral air vents and passenger footwells.



Central and lateral air vents.





COMFORT

7 - Air flow

Heater blower speed: press button:



To increase it



To decrease it.

The level of air flow is represented on the display by the progressive filling of the fan blades.

A press on the control **7** deactivates the function "**AUTO**". To restart it, press again on the control **AUTO**.

Note: to avoid condensation and poor air quality in the passenger compartment, it is recommended always to maintain a sufficient flow of air.

8 - Demisting - deicing of the windscreen and front side windows



While it is operating, the warning lamp lights and the symbol appears on the display.

This control is for rapid deicing or demisting of the windscreen, acting automatically on the air blower flow, air distribution, air conditioning and air entry.

To stop it, press again on control **8** or on the control **AUTO**.

Note: you should not have air recirculation selected.

9 - Demisting - deicing of the rear screen



When this function is working, the warning lamp comes on and the symbol appears on the display.

This control is for rapid deicing or demisting of the rear screen.

It switches off automatically to avoid excessive consumption of power.

To stop it, press again on the control **9**.



Press AUTO to return the system to its automatic function.





COMFORT

SCENTED AIR FRESHENER



The scented air freshener is located to the right of the central air vent. You can stop or adjust the flow of scented air, via control **1**.



To remove the cartridge, take the cap **A** off the new cartridge that you will fit and put it on the cartridge you are removing.



To remove the cartridge, take the cap **A** from your new cartridge and place it in the small orifice of the cartridge you are removing. Pull.

The central air vents should be open.

The cartridges need replacing from time to time.

As a matter of safety, use the scented air freshener and cartridges only for the purpose intended, in conformity with the user instructions.

Keep the cartridge packaging together with the user instructions and precautions.

Do not dismantle the cartridges.

Do not touch the scent mesh.

Never try to refill the scented air freshener or the cartridges with a freshener other than those approved by CITROËN.

Keep these items away from children and animals.

Avoid them coming into contact with the skin or eyes.

In the event of ingestion, consult a doctor and show him the packaging or the label.

Do not install, remove or adjust a cartridge while driving.





COMFORT

FRONT SEATS

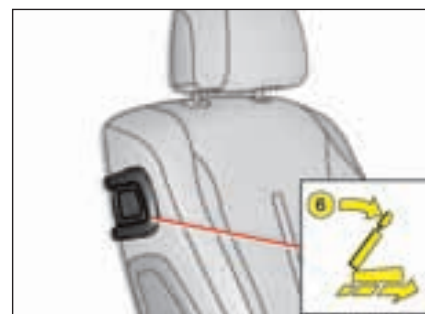
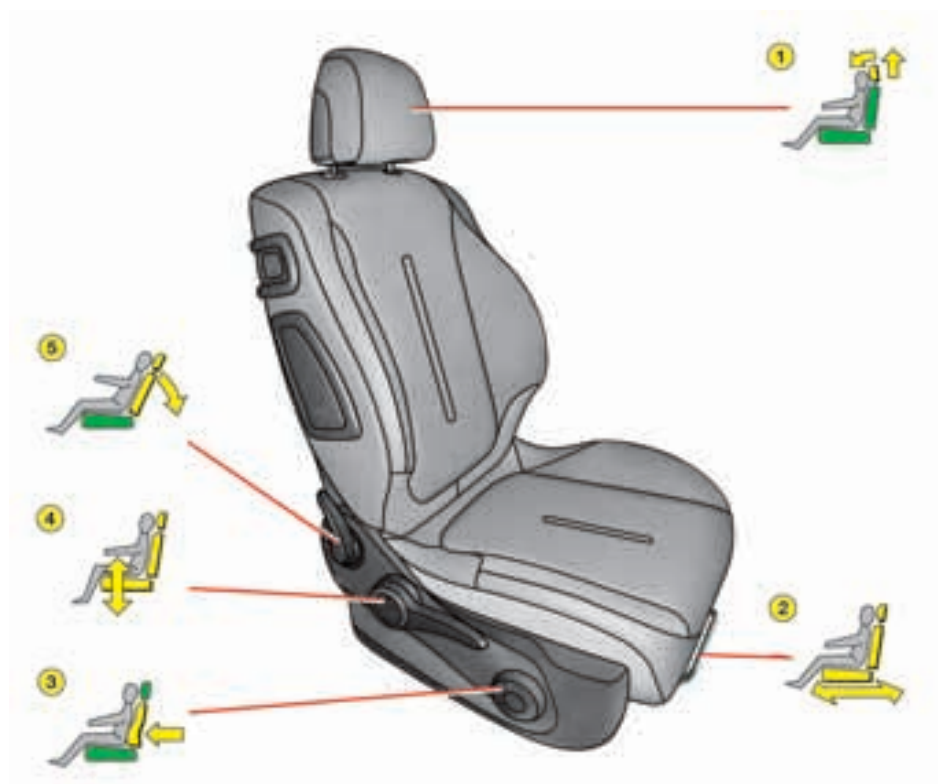

III





COMFORT

Manual adjustments

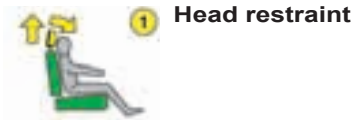

1 Head restraint

To raise, pull upwards. To lower, press on the unlocking button and on the head restraint. The adjustment is correct when the upper edge of the restraint is level with the top of your head. The head restraint is also angle-adjustable.

To remove, press on the unlocking button and pull upwards.

Note: Never drive the vehicle without the head restraints fitted.

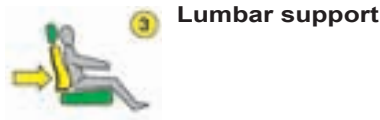

3 Lumbar support

Turn the control to adjust the seat to the desired position.



4 Driver's seat height

Raise or lower the control the number of times required to obtain the desired position.



5 Backrest angle

Use the control **A** to adjust the backrest angle.

It is possible to recline the backrest to an angle of 45° by tilting it until it locks; press the control to unlock.



6 Access to the rear seats

To access or exit the rear seat positions, tilt the control **6** towards the front to fold the front seat back-rest and slide the front seat forwards.

Afterwards the front seat will revert to its initial position.

Make sure that the seat is securely locked in place.



2 Reach

Lift the control bar and adjust the seat to the desired position.





COMFORT

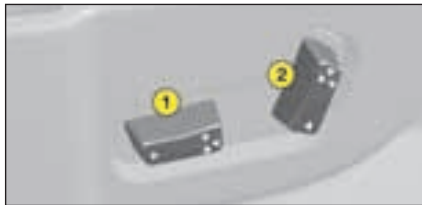

Electrically operated adjustments

- ① Adjustment of seat height, angle and reach
- ② Adjustment of backrest angle and lumbar support



① Raise or lower the front of control 1 to make the front of the seat cushion higher or lower.



① Raise or lower the rear of control 1 to make the seat higher or lower.



① Action control 1 to the front or to the rear to move the seat forward or back.



② Push the top of control 2 forward or back to adjust the backrest angle.



② Raise or lower control 2 to increase or decrease the lumbar support.

Note: The seats can still be moved on a temporary basis:

- when opening one of the front doors.
- after switching off the ignition.



Heated seats

The front seats can be heated independently. Use the controls placed on the sides of the seats, turning them to select one of three heating levels:

- 0: Off.
- 1: Gentle heat.
- 2: Medium heat.
- 3: Strong heat.

The seat temperature will adjust accordingly.

Note: The heated seats will only operate when the engine is running.





COMFORT



III

Memorisation of driving positions

You have the possibility to memorise two driving positions, via the buttons **M/1** and **M/2**.

Memorisation using the buttons

To memorise, using the buttons located on the side of the seat:

- turn the ignition key to the drive position,
- adjust your seat and your exterior rear view mirrors,
- press on button **M** then immediately on button **1** "first driving position" or on button **2** "second driving position".

The memorisation is recognised by an audible signal. Memorising of a new position cancels the previous one.

Recall of a memorised driving position

Vehicle stopped (ignition on or engine running)

- Press briefly on button **1** or **2** to recall the corresponding memorised position.

Note: after five consecutive recalls of a memorised position, this function will be deactivated until the engine is started.

Vehicle moving

- Keep button **1** or **2** pressed to recall the corresponding memorised position.





COMFORT

REAR SEATS

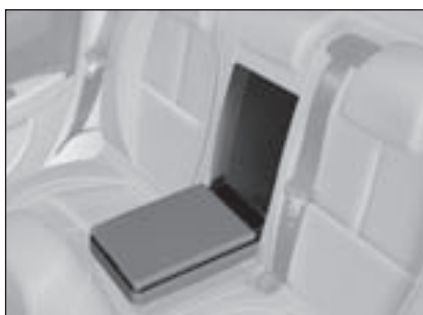

Rear armrest

- Lower the rear armrest to improve your comfort.
- Lift the cover for access to its storage box.

This can contain a storage box, two cup holders and two pen holders.

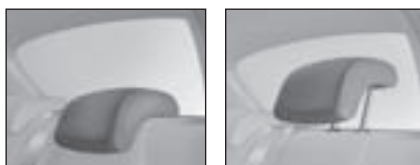

Rear head restraints

The rear head restraints have two positions:

- A low stowed position when the seat is not occupied.
- A raised position to optimise the safety of the passenger, by raising it to its stop, **including when used with a forward facing child seat.**

To lower the head restraints, press on the unlocking controls.

To remove them, pull upwards as far as permitted, then press on the unlocking controls.

Note: Never drive the vehicle without the head restraints fitted.



Folding the seat cushion

- raise the front of the seat cushion,
- tilt it towards the front seats.

When repositioning the seat base, make sure that the seat belt buckles are back in place.

Note: When you fold a rear seat cushion, you should also fold the corresponding backrest.

Before folding the seat

Before tipping the rear seat, make sure that the seat belts will not be snagged or trapped by the seat and its catches.

Position them carefully to the sides of the backrests.





COMFORT

III



Folding the backrest

Stow the head restraints.

Press on control **A** located on the extremity of the backrest and tilt fully forwards.

When returning the seat backrest to the normal position, ensure that it locks into place: the red warning indicator, located on the control, must not be visible.



When you are handling the rear seats, avoid trapping the seat belts and make sure that the belt buckles are positioned correctly.

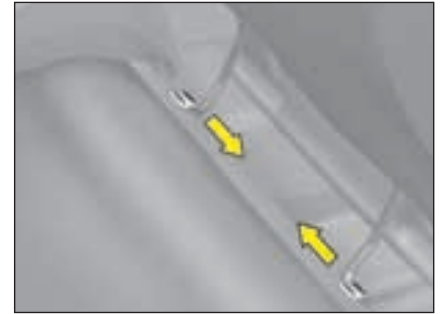

Removing the seat base

To improve seating versatility, the rear seats are removable.

Detach one of the linkages from its securing point, then disengage the other linkage to remove the seat assembly.





COMFORT

DOOR MIRRORS



Adjustment of rear view mirrors

Functions with ignition switched on.
From the driver's position, select the rear view mirror via the control **1**, then adjust in the four directions by moving the control **2**.

Deicing of rear view mirrors is coupled with electric demisting of the rear screen.

Fold-back of door mirrors

When the vehicle is parked, the door mirrors can be folded back either manually or electrically.

Electric fold-back

From the central position, one press towards the rear on control **1** folds the rear view mirrors back.

To return them to the initial position, press again on the control towards the rear.

Automatic electric fold back

Automatic fold-back operates when you lock the doors with the remote control.

The opposite movement applies when you unlock the doors, except if you operated fold-back before switching off the ignition.

Note: Automatic fold-back of the rear view mirrors can be deactivated. Consult your CITROËN dealer.

Automatic tilting of mirrors when reversing

This function automatically gives you a view of the ground while reversing the vehicle.

Activation

With the engine running:

- Select the rear view mirror using control **1**.
- Engage reverse gear, the mirror glass automatically positions itself to improve your vision of the pavement.
- If necessary, adjust the mirror to your preference using the electric control **2**.

Deactivation

To deactivate the function, move control **1** to the central position.





COMFORT

INTERIOR REAR VIEW MIRROR



Manual interior mirror

The lever on the lower edge enables you to place the rear view mirror in either of two positions:

Day position: the lever is not visible.

Night position (antidazzle): the lever is visible.



Automatic photochromic interior rear view mirror

This provides an automatic and progressive changing between day use and night use.

To avoid causing dazzle, the mirror automatically becomes darker depending on the intensity of light coming from the rear. It becomes lighter as soon as brightness diminishes, thus ensuring optimal vision.

To operate

Switch on the ignition and press control **1**.

- Warning lamp **2** on: automatic mode.
- Warning lamp **2** off: automatic mode stopped. The mirror remains in its lightest definition.

Note: for optimal vision, the mirror lightens automatically when reverse gear is engaged.

STEERING COLUMN ADJUSTMENT



Both the height and reach of the steering wheel can be adjusted.

With the vehicle at rest, first adjust the seat to the most suitable position, then adjust the position of the steering wheel.

Adjustment

Unlock the steering by pulling the control towards you.

Adjust the steering wheel position then lock by pushing the control fully downwards.

If you press firmly downwards on your steering wheel after locking, you may hear a slight click. The steering is then in its definitive position.

As a safety measure, do not adjust your driving position while driving.





ACCESS

KEYS



The key operates all the vehicle's locks as well as the ignition.

Note: For safety reasons, a buzzer will sound if you have switched off the ignition and opened the driver's door without previously removing the ignition key.

The key is used to deactivate the passenger's front airbag (see "Safety").



Advice

For any modification concerning the keys it is **essential** to contact a CITROËN dealer taking **all of the keys** in your possession with you.

Central locking using the key

A brief action with the key locks the vehicle.

Central deadlocking using the key

A second action straight away with the key deadlocks the vehicle. It is then impossible to open the doors from either inside or outside the vehicle.

A long action with the key closes the windows.

Note: With the vehicle stationary and the engine switched off, locking is signalled by the flashing of the interior locking control warning lamp.

If any of the doors, or the boot, is open or not properly closed, central locking does not operate.

Electronic immobiliser

The key contains a coded electronic chip. When switching on, the code must be recognised to allow the engine to be started.

This electronic immobiliser locks the engine management system a few seconds after switching off the ignition, and prevents unauthorised starting of the engine.

If the key is not recognised, starting is not possible.

If this occurs, leave your vehicle immobilised and contact a CITROËN dealer.

IV



It is dangerous to deadlock the vehicle when someone is inside as unlocking from the interior is impossible (without the remote control).

In the event of loss of the keys go to a CITROËN dealer with proof of ownership of the vehicle.

The CITROËN dealer network will be able to recover the key code and the transponder code to order replacement keys.

57





ACCESS

REMOTE CONTROL



IV

Central unlocking

A short press on button **B** unlocks your vehicle.

This operation is confirmed by the rapid flashing of the direction indicators and the lighting of the interior lamp (if the function is activated). It can also deploy the exterior rear view mirrors.

Central locking, closing windows, deadlocking

- A short press on button **A** locks your vehicle.

- A long press on button **A** locks your vehicle and closes the windows.

This operation is confirmed by the direction indicators illuminating for approx. two seconds and by the interior lamp switching off. This also folds the exterior rear view mirrors.

If any of the doors, or the boot, is open or not properly closed, central locking does not operate.

For vehicles equipped with deadlocking, two successive presses on button **A** deadlocks the vehicle.

It is then impossible to open the doors from either inside or outside the vehicle.

Note: The simultaneous use of other high frequency equipment (mobile telephones, domestic alarms...) may momentarily hinder the operation of the remote control.

In the event of a permanent fault, the remote control should be reinitialised. (See next page).



It is dangerous to deadlock the vehicle when someone is inside as unlocking from the interior is impossible (without the remote control).

When closing the windows using the remote control, the user should make sure that nobody is obstructing the windows from shutting properly.





ACCESS

Guide-me-home lighting

A press on button **C** operates the guide-me-home lighting (illumination of the sidelamps and dipped beams for approx. one minute).

A second press prior to the end of this timing cancels the guide-me-home lighting.

Locating of the vehicle

To locate the vehicle in a carpark, press button **A**, the interior lamps come on and the direction indicators flash for a few seconds. The vehicle remains locked.

Folding and ejection of the key

Button **D** is for folding and ejecting the key from its housing in the remote control.

If you do not press on button **D**, you could damage the mechanism.

Take care not to place the remote control in contact with grease or dust, or leave it in the rain or in a damp environment. A hard object also on the key ring, pressing on the key while it is in the ignition, can cause a malfunction.

Changing the remote control battery

Unclip the cover to gain access to the battery.

Battery: CR 0523: 3 V.

Re-initialisation of the remote control

After a change of battery, it is necessary to re-initialise the remote control. To do that, switch on the ignition and immediately action button **A** on your remote control to trigger the action desired. This may take some ten seconds.

Do not throw away the old batteries. They should be returned to the CITROËN dealer or deposited in a recognised recycling facility.

Except when reinitialising, the remote control cannot function while the key is in the ignition, even when switched off.

Warning: By inadvertently actioning the remote control, when for example it is in your pocket, you can unlock the vehicle without your realising it.

However, if no door is opened with 30 seconds of unlocking, the vehicle locks itself again automatically, without arming the alarm.

Warning: There is a risk of damage if the replacement battery is not the correct one.

Only use batteries that are identical or equivalent to those approved by CITROËN.





ACCESS

ANTI-INTRUSION ALARM



Your vehicle may be equipped with an anti-intrusion alarm.

This ensures:

- Exterior perimeter protection by means of detectors on the access points (doors, tailgate, bonnet) as well as on the electrical supply.
- Interior volumetric protection by means of ultrasonic sensors (detecting movement inside the passenger compartment). This can be deactivated using control 1.



The installation also includes a siren and a warning lamp 2 visible from the outside, indicating the three possible alarm statuses:

- Alarm not armed (not on standby), warning lamp off.
- Alarm armed (on standby), the warning lamp flashes slowly.
- Alarm triggered (signalling an intrusion), the warning lamp flashes rapidly if the alarm is disarmed with a press on button B. It stops flashing as soon as you switch on the ignition.

Note: in the event of a malfunction, the warning lamp 2 comes on continuously.

Arming the alarm using the remote control

Switch off the ignition and leave the vehicle.

Ensure that all doors and the boot are closed.

Lock the vehicle using button A on the remote control.

When the alarm is armed, the protections become active within 5 seconds (perimeter) and 45 seconds (volumetric).

Triggering

Provided the alarm is armed, any intrusion triggers the siren for 30 seconds, accompanied by the illumination of the direction indicators.

The alarm then reverts to armed status, but the deployment remains memorised and is signalled by the rapid flashing of the alarm warning lamp 2 when you press the unlocking button B. The flashing stops when you switch on the ignition.

The siren is also triggered if there is a cutting of the electrical supply. To stop it, restore the electrical supply then give a press on the unlocking button B.





ACCESS

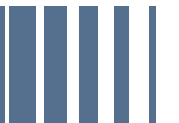

Disarming the alarm using the remote control

The alarm is disarmed when you unlock the vehicle (by pressing button **B** on the remote control).

Disarming the alarm using the key

Unlock the doors with the key. The siren is triggered. Enter the vehicle and switch on the ignition to stop the siren. Otherwise the siren will continue for about 30 seconds.

Note:

- *If you wish to lock your vehicle without arming the alarm, just lock the vehicle with the key.*
- *If you try to lock your vehicle when a door or the boot is still open, the central locking will not operate, but your alarm becomes armed after approx. 45 seconds.*

Note: *the siren is automatically disarmed (for example if you need to disconnect the battery) immediately after you unlock the vehicle using the remote control.*

Deactivation of volumetric detection

The alarm is able to operate with only perimeter protection if you deactivate the volumetric protection (if for example you wish to leave an animal in the vehicle).

To do this, switch off the ignition, then press immediately on control **1** for at least one second.

The warning lamp **2** should be on permanently. It will start to flash when the alarm activates.

Arm the alarm by locking your vehicle using the remote control.

Automatic activation (depending on country)

The alarm arms automatically 2 minutes after the boot or the last door is closed.

In order to prevent the alarm then being triggered by a door or the boot being opened, it is essential to press again on the unlocking button **B** on the remote control.





ACCESS

WINDOWS



Electric windows

The driver uses the controls located on the door to operate the vehicle's electric windows.

Note: the electric windows can also be operated for a limited time after the ignition has been switched off (including after the front doors have been opened).

Sequential electric window controls

There are two operating modes:

manual mode

Press or pull the control switch, without going beyond the point of resistance. The window stops on release of the control switch.

automatic mode

Press or pull the control switch beyond the point of resistance. The window opens or closes completely on release of the control switch.

Pressing or pulling the switch again stops the movement of the window.

Anti-pinch device

An anti-pinch device stops the window from rising. If it meets an obstacle, it goes back down.

After a battery disconnection or in the event of a malfunction, you have to **re-initialise** the anti-pinch function:

- Lower the window fully using the control, then close. It will rise only a few centimetres.
- Press repeatedly on the control until the window is fully closed.

Warning: During this operation, the anti-pinch protection does not work.

ALWAYS PAY ATTENTION TO WHERE CHILDREN ARE WHEN OPENING OR CLOSING WINDOWS.

- Always remove the ignition key when leaving the vehicle, even for short periods.
- If the driver is operating the passenger's electric window control, the driver should ensure that no passenger is obstructing the window from closing.
- The driver should check that the electric windows are used properly by the passengers.
- Should there be any risk of a person becoming trapped by a window closing, you should immediately reverse the window movement. To do this, reverse the position of the control concerned.





ACCESS

Electric child safety



This allows from the front, deactivation of the opening of the rear doors and the use of the rear windows.

It is activated by means of a press on control **A** located on the electric windows control panel. The warning lamp in the instrument panel lights up for approx. 10 seconds.

Each time the ignition is switched on, the warning lamp comes on for approx. 10 seconds.

Opening of the doors from the outside and operation of the rear electric windows remain possible from the front of the vehicle.

DOORS



Locking the doors from the inside

With the doors closed, press button **B** once to operate the electric central locking and unlocking.

The doors can still be opened from inside.

The central locking will not operate if a door is open, or not properly closed.

The lamp on the control **B** can signal any of 3 statuses:

- It flashes if the doors are open when the vehicle is stationary, engine stopped.
- It lights up if the doors are locked and the ignition is switched on.
- It goes out if the doors are not locked.

Note: Control **B** is inactive if the vehicle has been locked with the remote control or with the key.

Personal security

When the vehicle is started, the system automatically locks the doors and tailgate as soon as you reach a speed of approx. 10 km/h (6 mph).

Note: If a door is opened, this door will automatically relock as soon as the vehicle reaches approx. 6 mph.

Activation/Deactivation of the function

After switching on the ignition, give a long press on the central unlocking button until a message is displayed.

IV

 **If you decide to drive with the doors locked, remember that in the event of an accident this renders access more difficult for the emergency services.**





ACCESS

IV



Manual operation (emergency mode)

In the event of an electrical fault, it is possible to lock the vehicle's doors by actioning control **C** on each door. With the door open, insert the end of a key or similar item into the aperture and turn.

Close the door.

After a repair, normal functioning resumes using either the unlocking control **B**, the remote control, or the key used in the driver's door.



TAILGATE

Opening from the outside

Press upwards on lever **1** which is located between the number plate lamps.

Anti-theft security

In all cases, as soon as the vehicle is moving (at above approx. 10 km/h or 6 mph) the tailgate locks automatically. The tailgate unlocks when a door is opened or if the interior locking/unlocking button is pressed.



Closing the tailgate

Lower the tailgate, using the 2 handhold zones located on the tailgate interior trim.

Removing your fingers, press down to close.



Emergency unlocking

If there is a problem with unlocking the tailgate, it can be unlocked from inside the boot:

- insert a screwdriver or similar tool into hole **2** of the lock,
- turn it in order to unlock the tailgate.





VISIBILITY

LIGHTING CONTROLS

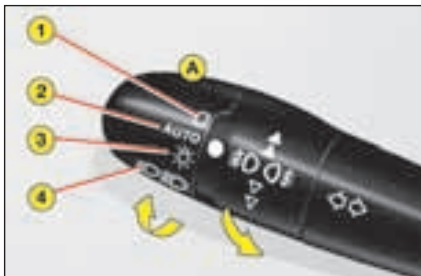

- 1 Off
- 2 Automatic lighting
- 3 Sidelamps
- 4 Dipped beam/Main beam



All lighting off

Turn the barrel **A** forward.



Automatic lighting of headlamps

Sidelamps and dipped beams come on automatically in conditions of poor ambient light or when the wipers are in continuous operation.

They go out as soon as the light is once again sufficient or approx. 5 minutes after the wipers have stopped.

To activate this function, place control **A** on position **2**.

Do not cover the brightness sensor, which is visible from the outside of the windscreen, behind the interior rear view mirror.

Turn the barrel **A** forward.



Sidelamps on

Turn the barrel **A** forward.



Dipped beams/main beams on

Pull the stalk towards you to change from dipped beam to main beam and vice versa.

Lights left on

An audible warning signal is triggered on opening the driver's door, ignition off, to indicate that the vehicle's lights are still on.

It stops on closing the door, switching off the lights or switching on the ignition.

There is no signal if automatic lighting or guide-me home lighting is activated.

Guide-me-home lighting

This function leaves the headlamps on temporarily to assist your exit in low light conditions.

This function is activated:

- Manually by pulling the lighting stalk towards you, ignition switched off.
- Automatically, provided that:
 - the automatic headlamp lighting has been activated,
 - the guide-me-home lighting has been activated. For this, select in the "Main menu", then in "Personalisation-Configuration", the lighting and signalling sub-menu and then activate the function.

See "Multifunction displays".

Note: It is possible to modify the duration of the guide-me-home lighting (approx. 60, 30 or 15 seconds) in the menu "Personalisation-Configuration".

For display **A** the period is fixed (approximately 30 seconds)

V





VISIBILITY

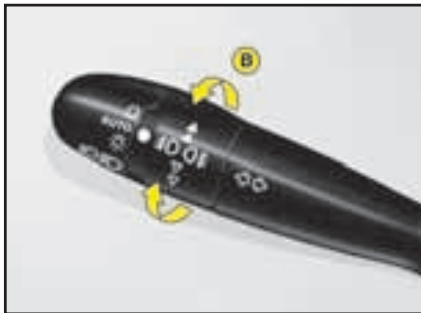

For a vehicle equipped with front and rear foglamps:

- 1st notch forwards: switches on front foglamps.
- 2nd notch forwards: switches on rear foglamps.
- 1st notch rearwards: switches off rear foglamps.
- 2nd notch rearwards: switches off front foglamps.

Note:

The rear foglamps must only be used when visibility is severely reduced (fog, snow).



HEADLAMP ADJUSTMENT

You are advised to adjust the aim of the headlamps in accordance with vehicle load.

In the dashboard on the right hand side of the steering column.

0. 1 or 2 occupants in the front seats.
- 3 occupants.
1. 5 occupants.
- Intermediate position.
2. 5 occupants + maximum authorised load.
- Intermediate position.
3. Driver + maximum authorised load.

Note: vehicles equipped with Xenon headlamps have automatic headlamp adjustment.

V

Vehicles with front and rear foglamps (Ring B)



They operate when sidelamps, dipped beams or main beams are switched on.

For a vehicle equipped with rear foglamps:

- 1st notch forwards: switches on rear foglamps.
- 1st notch rearwards: switches off rear foglamps.

In conditions of poor visibility, if the ambient brightness does not trigger the automatic lighting, it is up to you to switch on your dipped beams manually, as well as your foglamps.





VISIBILITY

SIGNALLING



Direction indicators

Left: move the stalk downwards.

Right: move the stalk upwards.

Movement of the steering wheel returns the stalk to the off position automatically.

Headlamp flash

Pull the stalk towards you to flash headlamps.

The headlamp flash operates even with the ignition off.



Hazard warning lamps

Simultaneous operation of the direction indicators.

Only use these if there is danger, for example when you have to stop suddenly or in unusual driving conditions.

They also operate without the ignition being on.

Driving with the hazard warning lamps on renders the direction indicators inoperable.

Emergency lighting of hazard warning lamps

Sudden vehicle deceleration automatically causes the hazard warning lamps to activate.

These cease automatically when you reaccelerate or manually if you press the hazard warning lamps control on the dashboard.

V





VISIBILITY

DIRECTIONAL HEADLAMPS

This function is associated with headlamps that have Xenon bulbs.

Whether on dipped beam or main beam, your headlamps follow the direction of the road ahead.

Lighting quality when driving round bends is considerably improved.



Function activated



Function deactivated

Activation/Deactivation

This can be activated/deactivated in the "Main menu". See "Multifunction displays".

See "Multifunction displays".

The status of the function is memorised on switching off the ignition.

By default, this function is in activated mode.

Note: At zero or very low speed, or in reverse gear, this function is inactive.

V

**If there is a malfunction, the "Dipped beams" warning lamp flashes.
Have the system checked by a CITROËN dealer.
You are recommended to have both Xenon bulbs changed if there has been a malfunction in either of them.**





VISIBILITY

SCREEN WIPE



Windscreen wiper stalk

- 2 Fast speed
- 1 Normal speed
- I Intermittent
- 0 Off
- AUTO** Automatic wiping.

Position I: The timing of the intermittent wipe adjusts automatically to the speed of the vehicle.

Position 1 or 2: when stationary, the windscreen wiper speed automatically reduces.

As a safety precaution, the wiper system is deactivated approx. 1 minute after the ignition has been switched off.

On switching the ignition back on, to reactivate the function:

- return to the **Off position**,
- change to the **position desired**.

Automatic wiping

AUTO position: press downwards to activate automatic wiping.

Press downwards: Automatic wipe activated.

Note: A press downwards triggers a single wipe, but without deactivating automatic wipe.

Deactivating automatic wiping

Go to position **I** then return to position **0**.

WARNING:

Do not cover the rain sensor, which is visible from the outside of the wind-screen, behind the interior rear view mirror.

When washing the vehicle, switch off the ignition or deactivate automatic wiping.

V





VISIBILITY

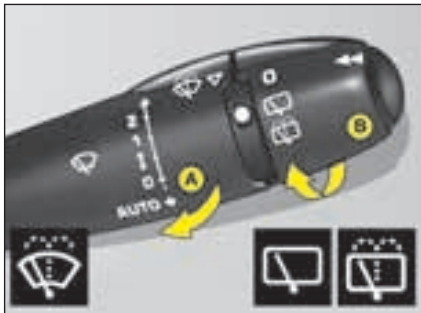

V

A - Windscreen washer

To operate the windscreen wash, pull the wiper stalk towards you.

Screen wash is accompanied by a timed screen wipe, the headlamp wash also operates if dipped beams are switched on.

B - Rear screen wiper



To deactivate.



Intermittent rear wipe.



Timed rear screen wash/wipe.

Reversing

On engaging reverse gear, if the front wiper is on, the rear wiper starts.

Activation/deactivation of this function is possible in the menu "Personalisation-Configuration" of the "Main menu".

Deactivation of this function is necessary when a bicycle carrier is installed on the tailgate.

Changing the wiper blades

The wipers should be stopped in the **maintenance position** (during replacement).

Switch off the ignition and action the wiper stalk within one minute. The wipers will position themselves in the middle of the windscreen.

For this, **switch off the ignition then, within one minute, action the wiper stalk**. The wipers will position themselves to the centre of the windscreen.

For optimum wiping performance, replace the wiper blades as soon as they leave traces on the screen; otherwise change them once or twice per year (in spring and autumn, for example).

Always check that the windscreen and rear screen wipers can operate freely, for example if fitting a bicycle carrier, or in freezing temperatures.

Remove any accumulation of snow from the base of the windscreen.





VISIBILITY



INTERIOR LIGHTING



1 - Spotlamps

A press on one of the buttons will switch the corresponding spotlamp on or off.

They will not come on if the ignition is switched off or the vehicle is in economy mode.

2 - Front and rear interior lamps



In this position, the interior lamp comes on when you open a door or the boot.



In this position, it is deactivated and switched off permanently.

In the front, the spotlamps are deactivated.



In this position, lighting is permanent.

Welcome lighting

Automatic lighting of interior lamps

- When you enter the vehicle:
They come on immediately you unlock the vehicle or open a door.
They go out 30 seconds after doors have been closed, or after the ignition has been switched on.
- When you leave the vehicle:
They come on when you remove the ignition key (for about 30 seconds), or when a door is opened.
They go out after 30 seconds with the doors closed, or immediately the vehicle is locked.





VISIBILITY



V

Glovebox lighting

Comes on automatically when the cover is opened.

Do not forget to close it again. Does not work with the ignition off.

Boot lighting

Operates automatically on opening the tailgate.

Sill lighting

These light up automatically with the interior lamps.



INTERIOR COMFORT

INTERIOR COMFORT



Glovebox

To open, pull the handle and lower the lid.

The glovebox has:

- Storage locations for pens, spectacles, telephone cards, etc.
- Three sockets for connecting audio/video equipment.
- A ventilation nozzle **A**, which can be closed manually. It delivers the same air-conditioned air as the front and lateral air vents.



WARNING: As a safety measure, the glovebox must remain shut when the vehicle is in motion.



Storage drawers

To open: press at the centre of the drawer.

To retrieve an object, lift the drawer up using the aperture provided.

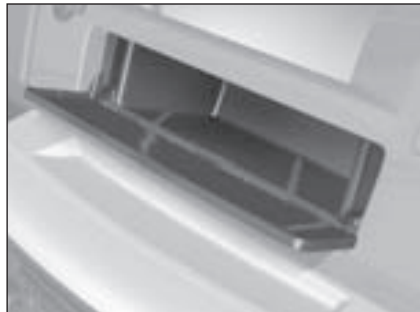

Storage flap

To open: press at the centre.

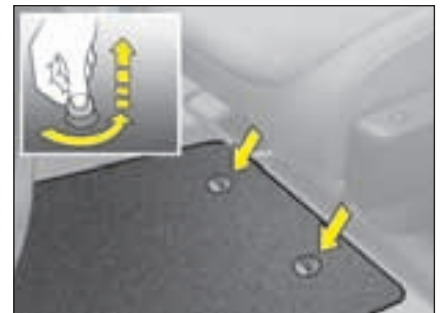

Floor mats

If removing the mat on the driver's side:

- slide the seat as far as possible rearwards,
- completely undo the fixings,
- remove the fixings, then the floor mat.

When refitting, position the floor mat correctly and press the fixings firmly home.

Check that the floor mat is securely in position.

To prevent any hindrance under the pedals:

- use only the floor mats that are compatible with the fixings already present in the vehicle. It is essential to use these fixings.
- never fit any further floor mats on top.



INTERIOR COMFORT



Storage pockets in the front doors and rear panels



Oddments tray on front central console

VI



Storage pockets





INTERIOR COMFORT

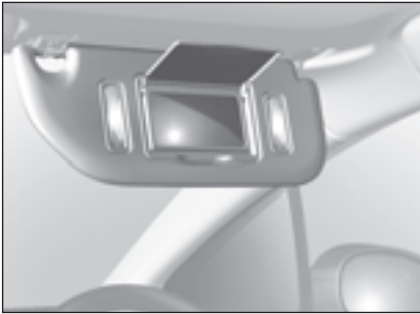

Sun visors

Fold visors down to avoid dazzle from ahead.

They can be disengaged from their central fixing and pivoted over to the side windows if required.

The passenger's and driver's sun visors each have a mirror that can be covered.

Sun visor with illuminated mirror

Illuminates automatically on opening the mirror cover flap (ignition on).



Glasses-holder

Toll payment/Parking windows

The heat-reflective windscreen includes a zone either side of the interior mirror base that allows optical reading of access badges (for a toll payment card, for example).



Carrier bag hook

- Press at the bottom to deploy the hook.
- Press at the top to stow the hook.

Grab handles/ Coat hooks





INTERIOR COMFORT



Cigar lighter

Operates when the ignition is on.
Push in and wait a few moments.
The cigar lighter will release automatically. The cigar lighter will gradually emerge for easy removal.

12 V accessories socket

(Maximum power: 120 Watts)
Operates when the ignition is on.
It is located on the central console.



Ashtray

To open it, lift the flap.
To empty the ashtray, lift at the rear and pull towards you.

To refit

Reposition the front part of the ashtray, then press on the rear part.



Panoramic roof

The roof has two opaque blinds positioned at the front and rear.
To close the front blind, pull the handle rearwards.
To close the rear blind, pull the handle forwards.
The blinds have a delay mechanism which stows them automatically when you release them.

VI





INTERIOR COMFORT

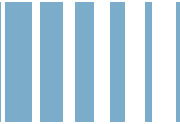

BOOT

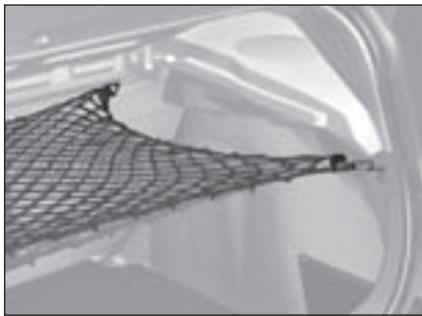

Luggage securing rings

Use the 2 side fixings at the rear, as well as the 6 anchoring rings on the boot floor and the rear seat backrest, to secure your loads.

For safety reasons, in case of hard braking, heavy objects should be placed as far forward as possible.

Protective net

This helps to secure objects stowed in the boot.

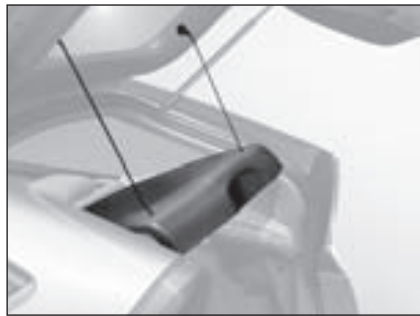

Removing the rear shelf (3- door model)

- Detach the cords.
- Carefully lift then pull, tilting it slightly on one side.



Removing the rear shelf (5- door model)

- Detach the cords.
- Carefully lift then pull.



Boot hook

Avoid using the rear shelf for heavy or hard items. These could be dangerous if thrown around during harsh braking or, if they touch the rear screen, could damage the heating elements.





CHILD SAFETY

When children are in the car

For maximum safety, consult the relevant authority in your country to be sure that you know the rules for the carrying of children. Observe the following recommendations:

- In accordance with European Regulations, all children of under 12 years of age or of height less than 1m 50 must be carried in approved child seats suitable for their age and weight, on seats equipped with a seat belt or ISOFIX anchorage. Check that the child seat is in compliance with current legislation, ensuring that it bears an orange label featuring the range of weights for which it is suitable as well as its approval no.
- **children under 9 kg must be carried in a rear-facing child seat, whether installed in the front or at the back.**
- It is recommended to use this position for as long as possible (up to 2 or 3 years old).
- Statistically, the safest seats for the carrying of children are the vehicle's rear seat positions.
- CITROËN recommends you to install your child in one of the rear seat positions, even when using a rear-facing child seat.

- Children must not under any pretext be carried on the knees of a passenger (risk of being thrown against the dashboard or windscreen should there be a collision).
- Children must not be allowed to stand between the backrests of the front seats, as they could be thrown forwards under sudden braking or in the event of a collision.
- The rear doors are equipped with a "Child Safety" locking device. This allows the doors to be opened from the outside unless they are under central locking.
- Each time you switch on the ignition, check that this device is activated.
- Never leave a child in a vehicle that is exposed to sunshine.
- Before opening a door, make sure that it is safe to do so.
- When leaving your vehicle, remove the ignition key and properly apply the parking brake.
- Do not leave the key in the vehicle, as children could lock themselves in, either using the remote control or by pressing the central locking button.
- Children should not be left alone in the vehicle.

Regulations for the carriage of children in the front passenger seat position

If the child is travelling in a rear-facing child seat, it is essential to deactivate the passenger's front airbag. Otherwise the child risks being killed or seriously injured should the airbag deploy.

In the front passenger's seat, children less than 10 years of age must not be carried "forward-facing", except if:

- The rear seats are occupied by other children.
- The rear seats cannot be used (if they are folded or not present).

If your child is travelling forward-facing in the front passenger seat position, slide the front passenger seat to an intermediate position and leave the airbag activated.





CHILD SAFETY

CITROËN offers you a complete range of child seats that can be secured by means of the vehicle seat belt. These child seats have been tested on vehicles in collision conditions and they guarantee maximum safety for your children. They have also been selected for their ease of installation as well as for the comfort of the child.

In all cases, be sure to follow the child seat fitting instructions as detailed in the installation manual provided by the seat manufacturer.

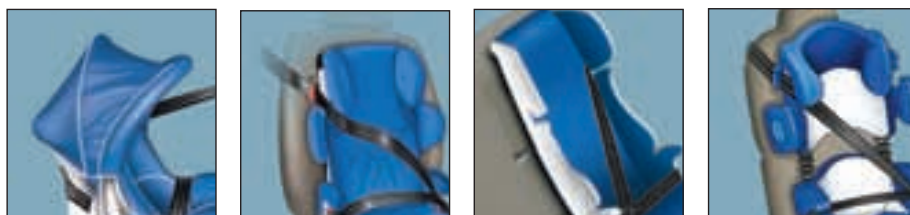

GROUP 0+ from birth to 13 kg (around 1 year old)

Römer Baby-Safe Plus (L1): rear-facing, for use with a three-point seat belt. The deep, reinforced shell is designed to provide the maximum protection to the child in the event of a lateral impact.

GROUPS 2/3 (from 15 to 36 kg)

Recaro Start (L2): for use with a three-point seat belt. The height and width of the backrest as well as the length of the seat cushion should be adjusted depending on the age and girth of your child.

Klippan Optima (L3): for use with a three-point seat belt. From 6 years old (approx. 22 kg), only height adjustment is required.

GROUPS 1/2/3 (from 9 to 36 kg)

Kiddy Life (L4): for use with a three-point seat belt. The height and width of the backrest as well as the length of the seat cushion should be adjusted depending on the age and girth of your child. For the safety of young children (from 9 to 18 kg), CITROËN recommends you to use the protection apron.

Other child seats are recommended: see ISOFIX child seats in the handbook. See "Child restraints".



"Passenger airbag OFF"

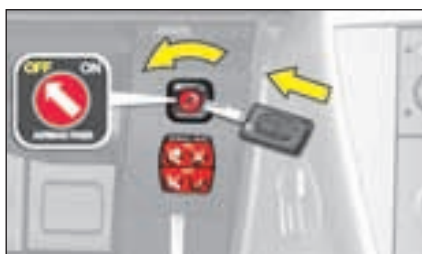

The majority of serious injuries resulting from accidents occur when a child either is not secured or is secured incorrectly. It is essential to adhere to the child seat fitting instructions as detailed in the installation manual provided by the seat manufacturer. ISOFIX child seats are particularly recommended for their ease and safety of use.

When a rear-facing child seat is installed on the front passenger's seat, the front passenger's airbag must be deactivated. Otherwise there is a risk of death or serious injury to the child on deployment of the airbag.





CHILD SAFETY

CHILD SEATS secured by means of the vehicle seat belt

In accordance with European Regulations, the table tells you to what extent each of the seat positions in your vehicle may take a child seat that is secured by means of the vehicle seat belt and approved as "Universal" depending on the weight of the child.

Seat(s)		Weight of child			
		Up to 10 kg Up to 13 kg (groups 0 and 0+)	9 - 18 kg (group 1)	15 - 25 kg (group 2)	22 - 36 kg (group 3)
Front passenger (a)	Fixed seat	U	U	U	U
	Height-adjustable seat	U(R)	U(R)	U(R)	U(R)
Lateral rear		U	U	U	U
Central rear		L1	X	L3	L3

U: Seat suitable for the installation of a universal rear-facing child seat and a universal forward-facing child seat

U(R): Seat position suitable for installation of a universal rear-facing child seat and of a forward-facing seat. The vehicle seat should be adjusted to the highest position.

(a) It is essential to deactivate the front passenger's airbag when a "rear facing" child seat is installed in the front passenger's seat position. Before placing your child in the front passenger's seat position, consult the legislation currently in force in your country on the carrying of children in this position.

L-: Only the child seats indicated may be installed in the seat position concerned (depending on country).

X: Position not suitable for installation of a child seat of the weight group indicated.

Take care to comply with the fitting instructions given in the child seat manufacturer's user guide.





CHILD SAFETY



ISOFIX anchoring points and the ISOFIX fastening system

The lateral rear seat positions are equipped with the ISOFIX regulation anchorages.



There are 3 rings for each seat position:

- Two "bottom" rings **a** and **b** located between the backrest and the vehicle seat. These are about 28 cm apart.



- One "top" ring **c** located in the boot between the wheelarch and the seat backrest.

ISOFIX child seats have two latches which are easy to secure on the two "bottom" rings **a** and **b**.

Some ISOFIX child seats also have a top belt, which is for attaching on the ISOFIX "top" ring **c**.

To attach the top belt, raise the head restraint of the vehicle seat, then pass the buckle between the two supports. Next fix the buckle on the "top" ring **c** and tension the top belt.

In all cases, the head restraint has to be raised to the maximum.

This fixing system is intended for children weighing up to 18 kg.





CHILD SAFETY



Incorrect installation of a child seat in a vehicle compromises protection of the child in the event of a collision.

The ISOFIX fastening system enables you to reduce those risks posed by incorrect fitting, offering you a convenient, strong and reliable fitting for a child seat in your vehicle.

The ISOFIX child seat recommended for your vehicle is: ISOFIX RÖMER Duo:

It is sold by the CITROËN network. This seat has an upper strap, which must be attached to the ISOFIX "upper tether".

The RÖMER Duo Plus ISOFIX is approved specifically for your vehicle.

If it is installed in a rear seat position, the vehicle's corresponding front seat should be adjusted so that the child's feet do not touch the backrest of this front seat.

This ISOFIX child seat can also be installed in seat positions that are not equipped with ISOFIX anchoring points. In this case, it is compulsory to secure it to the vehicle seat by means of the vehicle seat belt.

VII





CHILD SAFETY

LOCKING REAR DOORS



Manual operation

Rear doors are locked by operating the lever on the rear face of the door in question. When the manual safety is in use, the aperture is horizontal.



Electric operation

The electrical safety is activated by pressing the control located to the rear of the electric windows panel. This prohibits movement of the rear electric windows and rear passenger doors.

It is still possible to open the doors from the outside, provided the vehicle is not locked.



If the child safety lock is activated, the warning lamp comes on for approximately 10 seconds when switching on the ignition.

This system is independent of and in no way replaces the central locking.

Check the status of the child safety locks every time the ignition is switched on.

Always remove the ignition key when leaving the vehicle even if only for a short time.

In the event of a violent impact, the electric child safety locks are deactivated automatically to allow rear passenger to get out of the vehicle.





SAFETY

TYRE PRESSURE SENSORS

This function alerts you in the event of a tyre being deflated or punctured. For this purpose, sensors continuously monitor the condition of the vehicle's wheels.

This system does not absolve the driver of the need to check the tyre pressures regularly.

Under-inflation warning



The **SERVICE** warning lamp lights up and a vehicle outline is displayed. The wheel(s) concerned will be shown flashing on the vehicle outline. Check the tyre pressures as soon as possible.

Puncture



The **STOP** warning lamp lights up and a vehicle outline is displayed.

The wheel(s) concerned will be shown flashing on the vehicle outline. Stop the vehicle immediately, avoiding any violent actions on the steering wheel or brakes.

Change the damaged wheel (whether punctured or substantially deflated), have the tyre repaired as soon as possible, then check the tyre pressure as soon as you can after that.

The wheel affected will no longer be detectable by the alert system if it is in the boot or undergoing repair (information given by the vehicle outline). The spare wheel will not be monitored by the alert system.

Wheel without senso



The **SERVICE** warning lamp lights up and a vehicle outline is displayed. The wheel(s) concerned will be shown as absent on the vehicle outline. If you have not changed a wheel, this information indicates a malfunctioning of the system.

Consult the CITROËN network to have the defective sensor(s) replaced.

The deflation detection system is a driving assistance function which does not absolve the driver from the responsibility to be vigilant, or from the need to check the tyre pressures regularly (see "Vehicle identification").

This system does not absolve the driver of the need to check the tyre pressures on a regular basis (see "Identification"), to ensure that the vehicle behaves as it should and to avoid premature wear on the tyres, especially when the vehicle is being subjected to heavy loads or driven at high speeds.

Do not forget to check the tyre pressure on the spare wheel.

 **Any repair or any change of tyre, on a wheel fitted with a sensor, should be carried out by a CITROËN Dealer.**

The system may be affected from time to time by interference from radio transmissions on similar frequencies.





SAFETY

BRAKES

Braking system

Your vehicle's most important safety feature, the braking system, is provided by brake discs (or discs and drums) and a dual hydraulic circuit.

When the engine is running, power assistance is provided so that pedal effort is reduced.

- On wet roads, or after washing the vehicle, there can be a slight delay in brake response. From time to time, apply the brakes briefly so that the heat generated can dispel any moisture.



ABS - Anti-lock Braking System

This system improves vehicle safety by preventing the wheels from locking under emergency braking or when braking on surfaces offering poor adhesion.

It thus allows control of the steering to be retained.

The operational capacity of the various electrical components of the ABS is continuously monitored, both before and during your journey. On switching on the ignition, the ABS warning lamp will light up and then should go out after a few seconds.

If the warning lamp stays on, this means that the ABS has been disconnected because a fault was detected. If the warning lamp lights up when you are driving, this means that the ABS system is not active.

In either case, the normal braking system remains effective, as on a vehicle without ABS. Nevertheless, to restore the additional safety afforded by correct functioning of ABS, it is recommended that the vehicle be taken to a CITROËN dealer as soon as possible.

On slippery roads (loose stones, snow, ice, etc.), it remains essential to drive with caution.



If the parking brake is off, the lighting of this warning lamp, in conjunction with the STOP warning lamp, indicates that the brake fluid level is low or that the braking distributor is malfunctioning.

It is essential to stop the vehicle.

Contact a CITROËN dealer as soon as possible.

Emergency braking assistance

This system enables you in an emergency to achieve the optimum braking pressure, thus to reduce the stopping distance. It is triggered by your speed of action on the brake pedal, which reduces its resistance to that action. Keep the brake pedal pressed until the vehicle comes to a stop.

In the event of emergency braking, press and keep the pedal down very firmly without reducing the level of effort.

 **When the engine is not running, the braking system will not have power-assistance.**

The effort required on the brake pedal will be considerably increased.

Take all reasonable safety precautions if you have to move the vehicle.

Never drive the vehicle without the engine running.





SAFETY

ELECTRONIC STABILITY PROGRAMMES

Electronic Stability Programme (ESP) and Traction Control (ASR)

These systems are closely connected to the ABS and additional to it. Where a difference is detected between the trajectory followed by the vehicle and that wanted by the driver, the **ESP system** acts automatically on the brake of one or more wheels to return the vehicle to the trajectory wanted, within the limits of the laws of physics. The **ASR system** optimises traction and prevents wheel spin by acting on the brakes of the driving wheels. It also improves steering stability during acceleration.

Operation

When either the ESP or ASR system is brought into operation, the **ESP/ASR** warning lamp flashes.

Deactivation

In exceptional conditions (vehicle stuck in snow, soft ground, etc.) it may prove useful to deactivate the ESP/ASR system to allow the wheels to spin and thus regain traction.

Press on control **A**, the **ESP/ASR** warning lamp and the control light up. **The ESP/ASR systems are no longer active.**

The ESP/ASR systems will activate again:

- **Automatically** after the ignition has been switched off.
- **Automatically** when you drive at above approx. 30 mph.
- **Manually** with another press on control **A**.

Operational anomaly

If there is a system malfunction, the **ESP/ASR** warning lamp comes on. Contact CITROËN to have the system checked.

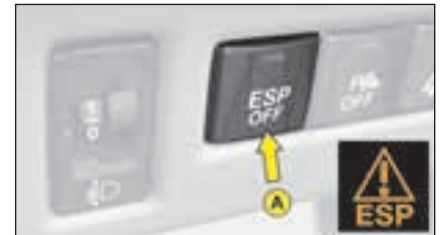

SAFETY RECOMMENDATIONS

The ESP system offers increased driving safety but is not in place to encourage the driver to take additional risks or to drive at excessive speeds.

The functioning of this system is subject to compliance with the manufacturer's recommendations on wheels (tyres and rims), brake parts and electronic components, as well as with CITROËN's assembly and repair procedures.

After any collision, have this system checked by a CITROËN dealer.





SAFETY



SEAT BELTS

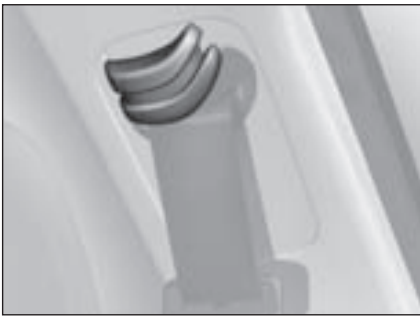

Seat belt height adjustment (5-door model)

The correct positioning for the seat belt anchorage is mid-shoulder height.

To adjust it, pinch the control and slide it in the desired direction.



Holding the seat belt (3-door model)

Raise then lock part **A**, to retain the seat belt buckle when it is unfastened.

It is necessary to remove the seat belt from the buckle retainer before moving the seat to access the rear seat positions.



As a safety measure, these operations should only be done at standstill.





SAFETY



VIII

Warning

When the pretensioners are deployed, there is a light discharge of harmless smoke and a loud noise, both due to the detonation of the integral explosive cartridges that activate them.

Depending on the nature and the force of the impact, this triggering may happen prior to, and independently of, the deployment of the airbags.

In all cases, the airbag warning lamp comes on.

Legislation makes it compulsory for all the vehicle's occupants to wear seat belts, including pregnant women and however short the journey.

Inside the cabin, the seat belt is the most important protection for passengers.

A warning lamp informs you if the driver's and/or front/rear passengers' seat belts are not fastened, when the ignition is switched on.

In the event of a collision or on emergency braking, the seat belt will hold you in your seat, preventing you from being thrown from the vehicle.

Pyrotechnically pretensioned seat belts with force-limiters

In the event of a collision:

- The pretensioners pull back the front seat belts. The occupants are thus held more firmly against their seats.
- The force limiters reduce the pressure of the seat belt against the occupant's chest, thus enhancing the protection that the seat belt provides.



Seat belts and pyrotechnic pretensioner systems

They must be replaced following a deployment, preferably by a CITROËN dealer or by an authorised repairer.

Due to the safety regulations in force, any check or any replacement should preferably be carried out by the CITROËN network which guarantees the work and ensures that it is done correctly.

Any repair that is not done in strict compliance with requirements could result in the systems operating incorrectly or randomly, with the risk of bodily injuries being caused.





SAFETY



Fastening

Pull the belt down in front of you in a steady movement, making sure that it does not become twisted.

Press the fastening into its buckle.

Check that the seat belt has fastened correctly and that the automatic reel lock is working correctly by pulling the strap.

The abdominal part of the strap should be positioned as low down as possible in the lap and as tight as possible.

The chest part should be positioned if possible in the channel of the shoulder.

Each belt has a reel that adjusts its length automatically to the girth of the seat occupant.

Unfastening

Press the red button on the buckle to unfasten the belt.

The belt retracts automatically when not in use.

Recommendations

To be effective, a seat belt:

- Must be able to restrain a single person of adult size.
- Must not bear any signs of being cut or frayed.

Do not swap buckles, as then they would not fulfil their proper roles.

Before and after use, make sure that the belt is correctly retracted.

If the seats have armrests, the central part of the belt should pass underneath.



Positioning of the belt recommended for pregnant women

Position the lower part of the belt as low down as possible on the lap, so that it exerts no pressure on the abdomen.



- **Always adjust your seat belt while the vehicle is stationary.**
- **The driver must ensure that all the passengers have correctly fastened their seat belts.**
- **Do not pass the belt over hard or breakable objects that you may have in your pockets.**
- **Never use clamps or clips to loosen your seat belt.**
- **Never carry a child on your knee.**
- **Regularly check the condition and cleanliness of the seat belts. See "Maintenance".**
- **Have the seat belts checked periodically by a CITROËN dealer as well as after any accident, even a minor one.**





SAFETY

AIRBAGS

Your vehicle may have:

- A driver's airbag located in the steering wheel, under the central cover.
- A passenger's airbag in the dashboard.
- Two side airbags located in the backrests of the driver's seat and front passenger's seat (door side).
- Two curtain airbags located on the interior edges of the roof.

The control unit for the airbags and sensors analyses any frontal and lateral impacts suffered in the collision detection zones (see illustration p 91).

According to the degree of seriousness of impacts, it determines:

- Whether the seat belt is sufficient to protect you (Slight impact).
- Whether the seat belt pretensioner needs to be additionally actioned in order to hold you in your seat (Medium impact).
- Whether the airbag should be deployed in addition to the two initial systems (Violent impact).

Never deactivate the passenger's airbag when a passenger is present (unless a child in a rear-facing child seat). See "Passenger's airbag deactivation".

Each time you switch on the ignition, a warning lamp in the dashboard lights up for a few seconds and then goes out.



Replacement of the pyrotechnic systems associated with the airbags

After the airbags have been deployed, the pyrotechnic systems have to be changed in strict compliance with the manufacturer's specifications.

Consult a CITROËN dealer in the following situations:

- The warning lamp flashes for a few minutes then remains on.
- The warning lamp does not light up.
- A message appears on the display.





SAFETY



Examples of impact detection zones

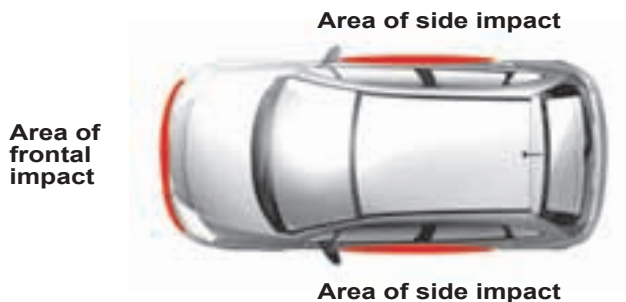

Front airbags and knees airbags

For these airbags to deploy, it requires a violent frontal impact applied on all or part of the frontal impact zone (see illustration) from forward of the vehicle in a horizontal plane.

The airbag interposes itself between the vehicle's front occupant and the dashboard to cushion the person from being thrown forward. The airbag thus limits the risk of trauma to the head and chest. For the driver, the knees airbag protects the knees.

The front passenger's airbag can be deactivated. see "Passenger's airbag deactivation".

Side airbags and curtain airbags

Deployment of these airbags requires a violent lateral impact applied on all or part of one of the lateral collision zones, coming in a horizontal plane from the side.

The role of the side airbag is to place itself between the occupant (driver or front passenger) and the door panel, thus limiting the risk of injuries to the chest.

The role of the curtain airbag is to place itself between the front or rear occupant and the windows, thus limiting the risk of injuries to the head.

These airbags may not deploy if there is only a slight collision on the side of the vehicle, or if the vehicle rolls over. They will not deploy for a front or rear collision.





SAFETY



The front passenger's airbag can be deactivated.



Passenger's airbag deactivation

In order to be able to use a "rear-facing" child seat in the front passenger position, it is essential to deactivate the passenger airbag.

To do that :

- With the ignition off, insert the key into the switch **A**, located in the glovebox.
- Turn the key to position **"OFF"**. The passenger's airbag is deactivated.

The front passenger airbag deactivation warning lamp in the instrument panel lights up (ignition on).

To reactivate the front passenger's airbag

Don't forget to reactivate the airbag function for a passenger or a forward facing child seat.

To do that, with ignition switched off:
- Insert and turn the key to the **"ON"** position, the airbag is activated.

The warning lamp in the instrument panel comes on for a few seconds when you switch the ignition on.



If there is a malfunction, the "airbag fault" warning lamp comes on.

In the front passenger's seat position, it is essential to deactivate the front passenger's airbag whenever a "rear-facing" child seat is installed there.

Otherwise the child risks being killed or seriously injured should the airbag deploy.





SAFETY



The wearing of seat belts is compulsory for all vehicle occupants. Inside the cabin, the seat belt is the most important protection for passengers.

The airbag is a protection in addition to the seat belt. Its effectiveness requires the seat belt to be worn correctly.

Children under ten years of age should always be carried in the rear seats. See "Child safety".

The driver and passengers must adopt a normal, vertical sitting position that is compatible with deployment of the airbags. See "Driving position".

Never attach anything to the steering wheel central cover, to the sides of the front seats or to the vehicle pillars or roof (risk of injuries should the airbags deploy).

Hold the steering wheel in the "quarter-past-nine" position: do not hold it by the branches or rest your hands on its central cover.

Smoke as little as possible in the vehicle (risk of burns or injury should the airbag be deployed).

Do not leave any accessory or object on the dashboard or between your body and the airbag (risk of malfunction or personal injury).

Fit only seat covers that are approved by CITROËN.

Do not put your feet on the dashboard (risk of injury should the front passenger airbag deploy).

The airbags do not deploy in the case of a slight collision or an impact at the rear of the vehicle or in certain manoeuvring conditions.

The deployment of one or more airbags is accompanied by a small release of unarmful smoke, as well as by a detonation that is caused by the activation of the pyrotechnic cartridge integral to the system. This smoke is not toxic but may be an irritant to persons who are sensitive.

The noise of the detonation may affect hearing for a brief time.

Vacate the vehicle as soon as possible after the accident (provided it is safe to do so). If this is not possible, open the windows or doors.

Even observing all the advised precautions, the risk of injury or slight burning to the head, chest or arms during deployment of an airbag cannot be ruled out. In fact, inflation of the airbag is virtually instantaneous (approx. 30 milliseconds); then it deflates in the same time, emitting hot gases through holes provided for this purpose. This equipment works only once. It cannot operate to provide further protection in the event of a second impact.

It is imperative to have the system overhauled in strict compliance with the manufacturer's specifications.





SAFETY

SAFETY ADVICE

Any operation under the bonnet necessitates a number of safety precautions.

Be particularly careful both before and during all checks under the bonnet:

- Allow the engine to cool down.
- Keep children away from the vehicle.
- Make sure that you possess the necessary tools and expertise.

Bonnet

Before opening the bonnet, make sure that your hands and clothing are protected. Allow the engine to cool down.

Make sure that the bonnet is stable in the open position. Beware of gusts of wind that could cause the bonnet to fall and cause serious injuries.

Moving parts

There will be a certain number of moving parts when the engine is running.

Even when the engine is switched off, the cooling fan could still operate without warning. **Do not wear loose clothing (ties, scarfs, etc.)**, tie back long hair, all of which could become entangled in a pulley or be dragged into a drive belt.

Work in safety

The first rule of safety is to choose a suitable environment.

Do not use open roads or public rights of way. Other traffic represents a hazard.

If you need the engine running, work outdoors and **not in** a confined space as there is a health risk from exhaust gases.

Make sure that your vehicle is not parked over inflammable materials (dry grass, fuels, etc.) as the very high temperatures associated with the catalytic converter could ignite them.

Choose firm, level ground sheltered from the wind. Keep children away from the vehicle.

On the road

If a warning lamp comes on while you are driving, stop the vehicle with due regard to the safety of other road users and switch off the ignition.

Puncture

Switch on your hazard warning lamps and get all passengers away to a place of safety, well away from the traffic (for example behind crash barriers or on the grass verge).

Position the jack correctly to ensure that the vehicle is stable. See "Changing a wheel".

Never attempt any repairs under a vehicle that has been jacked up, without first supporting it on axle stands or some other reliable support.





SAFETY

Radiator

In normal usage, the coolant temperature reaches or exceeds 100 °C. **Never remove the cap of a radiator that is hot:** there is danger from projection of scalding liquid and steam. See "Levels".

The antifreeze contained in the coolant lends it the following properties:

- Protection against low temperatures (initial protection: -35 °C).
- Anti-corrosion protection.
- Resistance to high operating temperatures.

See the Maintenance Guide.

Oil

In normal use, the engine oil can exceed temperatures of 130 °C and thus can cause serious burns.

Exhaust system

Beware of the very high temperatures attained by the various components of the exhaust system (risk of burns).

Fuel cut-off switch

Your vehicle is equipped with a safety device which cuts off the fuel supply in the event of a collision.

Petrol

Be extremely careful when decanting or draining petrol or when repairing petrol leaks because of the high risk of fire.

Diesel fuel

The diesel fuel system of an HDi vehicle is a high pressure system. Any repair work must be carried out by suitably qualified personnel, such as can be guaranteed by the CITROËN network.



At all times:

- Avoid attempting repairs while close to moving traffic. If this is absolutely necessary, take all possible precautions.
- Ensure that your passengers seek safety away from the vehicle and off the roadway (road verges and motorway hard shoulders are not safe places).
- Keep children away from the vehicle and in safety.
- Operate the hazard lamps and erect warning signs.
- Preferably summon assistance from a CITROËN-approved breakdown service.
- For guaranteed quality and safety, use CITROËN products.





SAFETY

LANE DEPARTURE WARNING SYSTEM



This driving assistance device alerts you if you are wandering from your lane (continuous or dotted line marking on the road surface).

It is designed especially for use on motorways and dual carriageways, operating only at speeds above 80 km/h (approx. 50 mph).

Activation/Deactivation

A press on control **A** activates the function, the warning lamp on the control lights up.

A second press on control **A** deactivates the function, the warning lamp on the control goes out.

Whenever you start the engine, the mode (activated/deactivated), selected when you last switched off the engine, is retained.

Operation

Provided you are travelling at over 80 km/h (approx. 50 mph), if you cross a lane marking, you are alerted by a vibration within the cushion of your seat:

- oriented to the right for crossing a lane marking to the right,
- oriented to the left for crossing a lane marking to the left.

The system does not alert you while your direction indicator is operating, nor for about 20 seconds after your direction indicator has stopped.

The effectiveness of the system may be temporarily affected by conditions external to the vehicle:

- Detection of lanes made difficult by:
 - Markings that are worn or erased.
 - Insufficient contrast with the surface of the road.
- Masking of the sensors due to:
 - Driving in snow or heavy rain.
 - Driving on roads covered with mud or surface water.

If the system is ineffective for a prolonged period, contact a CITROËN dealer.

Note: This device is designed to identify traffic lane markings.

In certain specific instances, it may trigger an unwanted alert, for example when you cross a direction arrow or some other random marking.



The driver must still remain attentive and in complete control of the vehicle.





DRIVING

HANDBRAKE



To release the handbrake, press on the end of the lever, pull the lever up then lower it fully.

The warning lamp will come on if the handbrake is on or not fully released.

Before leaving the vehicle, make sure that the parking brake is sufficiently applied to prevent the vehicle from moving if on a slope, or if accidentally or deliberately pushed.

As an additional precaution on steep slopes:

- Apply the parking brake.
- Engage a gear.
- Turn the steering wheel towards the kerb (if there is one).

The parking brake is applied, with the vehicle stationary, by pulling on the lever with a force that is proportionate to the steepness of the slope.

To facilitate the action on the lever, you are recommended to press the brake pedal at the same time.

In all circumstances, as a precautionary measure, engage first gear. For vehicles equipped with an automatic gearbox, ensure that the parking position (**P**) is selected.

On steep slopes, turn the steering wheel towards the kerb.





DRIVING

STARTING

Manual gearbox

- **Ensure that the gear lever is in the neutral position.**
- Do not touch the accelerator.
- In the case of diesel engine vehicles: turn the key to the drive position. Wait for the pre-heater warning lamp to go off, if it is on.
- Action the starter by turning the key until the engine starts (but not for more than ten seconds).
- In temperatures lower than 0 °C, apply the clutch during the action on the starter in order to aid starting. Then release the clutch slowly.

(6 speed) Electronic Gearbox System

- Check that you are in position **N**.
- Fully depress the brake pedal.
- Do not touch the accelerator.
- For Diesel engines: turn the key to position **M**. Wait for the pre-heater warning lamp to go off if it is on.
- Action the starter by turning the key until the engine turns over (not for longer than ten seconds).

Note: If the vehicle has been stationary for a long time, or if you have pressed the brake pedal a number of times while stationary, it will be necessary to press the brake pedal hard down in order to authorise the engine to start.

Automatic gearbox

- Check that you are in position **P** or **N**.
- Do not touch the accelerator.
- For Diesel engines: turn the key to position **M**. Wait for the pre-heater warning lamp to go off if it is on.
- Action the starter by turning the key until the engine turns over (not for longer than ten seconds).

IX



Advice

Vehicles equipped with a Turbo:

Turbo equipped engines **MUST** be allowed to return to idle for several seconds before switching off the ignition. Failure to do so could cause serious damage to the turbo unit.

Flicking the throttle pedal as the ignition is turned off can lead to severe damage to the turbo unit.



DO NOT RUN THE ENGINE IN A SPACE THAT IS ENCLOSED OR INSUFFICIENTLY VENTILATED.





DRIVING

MANUAL GEARBOX



5 speed gearbox

Reverse gear

Do not select reverse gear until the vehicle is completely stationary.

Depress the clutch pedal and wait a few moments before gently engaging reverse gear.



6 speed gearbox

Reverse gear

Lift the collar **A** to engage reverse gear.

Do not select reverse gear until the vehicle is completely stationary.

Depress the clutch pedal and wait a few moments before gently engaging reverse gear.





DRIVING

6-SPEED ELECTRONIC GEARBOX

The 6-speed electronic gearbox offers a choice of two driving modes:



An **automated mode** with the gear lever in position **A**.

A **manual mode** with two methods of operation:



- the gear lever in position **M**,



- the paddle controls behind the steering wheel.

For each of these two modes, a Sport option (corresponding to a more dynamic style of driving) is also available.



Display in the instrument panel

N. Neutral

R. Reverse

1, 2, 3, 4, 5, 6. Gears in manual mode

A1, A2, A3, A4, A5, A6. Gears in automatic mode.

S. Sport (Sport driving style)

Note: if you are in automatic mode, an instant manual mode activates whenever you action one of the controls at the steering wheel.





DRIVING

N**Neutral**

If the vehicle is moving, do not select this position, even momentarily.

R**Reverse gear**

Only engage reverse gear when the vehicle is stationary.

If the vehicle is moving at a very low speed, if reverse gear is requested (position **R**) this will be taken into account only when the vehicle comes to a halt.

The "foot on brake" warning lamp may flash in the instrument panel to remind you to brake.

If the vehicle is moving at a high speed, if reverse gear is requested the warning lamp "**N**" will flash and your vehicle will go automatically into neutral. To re-engage a gear, you have only to return the gear lever to position **A** or **M**.

A sound signal indicates when reverse gear is engaged.

If parking assistance is deactivated, the sound signal for reverse gear engaged is absent.

A**Automatic mode****M****Manual mode**

- Push the lever to change to a higher gear.
- Pull the lever to change to a lower gear.



The engine can only be started if the brake pedal is pressed and the gear lever is in position N.

The warning lamp "foot on brake" flashes on the display.

With the engine running, before accelerating away check the position engaged by looking at the lever grille or the rev counter: R, A or M.

If you are stationary with the engine running, take care to leave your gear selector in position N.

**Sport option****Activation**

Press on button **S**, situated on the lever grille.

The warning lamp "**S**" displays on the rev counter.

This option can be activated either in automatic mode or in manual mode.

Deactivation

Press again again on button **S** on the lever grille.

The warning lamp "**S**" disappears on the rev counter.

Note: the Sport option is deactivated whenever you switch off the ignition.

IX



DRIVING



Starting the vehicle

- To start the engine, the gear lever has to be in position **N**.
- Fully depress the brake pedal.
- Action the starter.
- With the engine running, depending on your preference place the lever on **R**, **A** or **M**.
- Check the position engaged on the rev counter.
- Release the handbrake.
- Release the brake pedal and accelerate.

If the lever is not in position **N**, the warning lamp "**N**" flashes on the rev counter.

If the brake pedal is not pressed down, the warning lamp "**Foot on brake**" flashes in the instrument panel.

In both cases, the engine does not start; recommence the above procedure.

Note: If the vehicle has been stationary for a long time, or if you have pressed the brake pedal a number of times while stationary, it will be necessary to press the brake pedal hard down in order to authorise the engine to start.

Stopping the engine

Before switching the engine off, you can choose:

- to leave the vehicle in neutral; for that, place the lever in position **N**,
- to leave the vehicle with a gear engaged (**R**, **A** or **M**); for that, place the lever in the position chosen. In this case, the vehicle cannot be moved.

In all cases, it is essential to apply the handbrake.

Before undertaking any operation in the engine compartment, make absolutely sure that the gearbox is in neutral and that the handbrake is on.

Acceleration

To obtain optimum acceleration (for example to overtake another vehicle), you have only to press the pedal hard down to go beyond the end-of-travel switch.



Do not hold the vehicle stationary using only the accelerator.

If you are stopped on an incline, use the handbrake to hold the vehicle.





DRIVING



Automated mode

Place the selection lever in position **A**.

"A" appears in the speedometer to confirm the selection made.

The gearbox then operates in autoactive mode, without intervention on your part.

It constantly selects the gear best adapted to the following parameters:

- Style of driving.
- Road profile.



Instant manual mode

Even in automatic mode, if you touch the controls under the steering wheel **"+"** or **"-"** you immediately change gear.

The **"A"** warning lamp remains displayed on the rev counter.

In the absence of any further action, automatic mode reactivates to cope with the prevailing driving conditions.



Cancellation of automatic mode

Move the gear lever from position **A** to select a different position.

The **"A"** warning lamp disappears on the rev counter.





DRIVING



Manual mode

Position the gear lever in position **M**, then:

- push the lever to engage a higher gear,
- pull the lever to change down.



Manual mode with controls behind the steering wheel

Place the gear lever in position **M**, and then the controls at the steering wheel will give you access to the six gears in forward drive.

To change gear:

- Press behind the control "+" at the steering wheel to engage a higher gear.
- Press behind the control "-" at the steering wheel to change down.

Note: These controls at the steering do not permit you to select neutral or reverse gear.

Observations:

When the vehicle is braking or reducing speed, the gearbox changes down automatically to a suitable gear.

In manual mode, it is not necessary to release the accelerator during changes of gear.

Changes of gear are accepted only if consistent with engine speed.



Under heavy acceleration, a higher gear will only be engaged when the driver actions the gear lever or the controls at the steering wheel.





DRIVING

HILL START ASSIST (with 6-speed electronic gearbox system)

To aid starting on a gradient, your vehicle is equipped with a system that keeps it temporarily immobilised.

It keeps the brakes applied for a brief moment, precisely the time taken for moving your foot from the brake pedal to the accelerator pedal.

This function is only active when the vehicle is completely stationary, with your foot on the brake pedal, in particular conditions on a slope.



On an ascending slope, with the vehicle stationary, the vehicle is held for a brief moment when you release the brake pedal, provided you are in **A** or **M**.



On a descending slope, provided the vehicle is stationary and reverse gear is engaged, the vehicle is held for a brief moment when you release the brake pedal.



Display of these warning lamps indicates a malfunctioning of the hill start assist function.



**Do not leave the vehicle during the hill start phase.
The hill start function cannot be deactivated.**





DRIVING

AUTOMATIC GEARBOX



The automatic gearbox offers:

D: operation in **auto-active automatic mode**, adapting automatically to your style of driving.

M: operation in **sequential mode**, with manual gear changing.

D and a press on button **S** or : operation in **automatic Sport** or **Snow mode**.

P: Park

R: Reverse

N: Neutral



Gear lever position

The position of the gear selector is displayed in the instrument panel.



Starting the engine

The engine can be started only in position **P** or **N**.

A safety device ensures that starting is impossible in the other positions.

After starting the engine, with selector on **P**, depress the brake pedal then shift the selector to **D**, **R** or **M**,

- **D** for automatic,
- **R** for reverse,
- **M** for manual operation.

A shift from **D** (automatic) to **M** (manual) is possible at any time.

For safety:

- The gear lever can only be disengaged from position **P** if **you are pressing the brake pedal**.
- When a door is opened, an audible signal sounds if the lever is not in position **P**.
- Before leaving the vehicle, make absolutely certain that the **PARK** or **P** position is selected.

IX





DRIVING



D Drive

The gearbox always selects the gear best adapted to the following parameters:

- style of driving,
- route profile,
- vehicle load.

In this way the gearbox operates in **autoadaptive** mode, without the need for your intervention.

For certain manoeuvres (for example overtaking), it is possible to obtain maximum acceleration by pressing hard down on the accelerator pedal, which may trigger automatic changedown to a lower gear.

Note

During braking, the gearbox may kick down automatically in order to offer an effective engine brake.

If you rapidly lift your foot off the accelerator, the gearbox will guard your safety by not changing up again.



M Sequential forward drive

Selector position for manual gear changing.

- Selector at **M**.
- Push the selector towards the sign "+" to change up a gear.
- Pull the selector towards the sign "-" to change down a gear.

Note: Passage from one gear to another is only possible when vehicle speed and engine speed permit.

The **Sport** and **Snow** programmes are not operative in sequential mode.

The change from position **D** (drive in automatic mode) to position **M** (drive in sequential mode) or vice versa may be effected at any time.





DRIVING



Operation in Sport or Snow automatic mode

Select the driving mode:

- Normal, for regular use, the warning lamps **S** and ❄️ are not illuminated.
- Sport, for more responsive driving, to provide maximum performance and acceleration.
- Snow, for smooth driving in wintry conditions.
- With selector on **D**, press button **S** the warning lamp **S** in the rev counter will light up, you are in "**SPORT**" mode.
- With selector on **D**, press button : ❄️ the warning lamp ❄️ in the rev counter will light up, you are in "**SNOW**" mode.
- Press button again, warning lamps **S** and ❄️ go out, the "**NORMAL**" mode is active.

IX



- Flashing of the warning lamp for the position requested signals that this position has not yet been permitted.
- When the warning lamp is fixed, the position is confirmed.
- The display of a dash in the rev counter indicates a fault.
Urgently consult a CITROËN Dealer

If there is a fault:

- A sharp hesitation may be felt when you select **R** for reverse gear.
- The gearbox is stuck in a gear.
- Do not exceed 100 km/h (approx. 60 mph).
Urgently consult a CITROËN Dealer





DRIVING



Park

Do not engage until the vehicle is completely stationary.

To avoid any movement of the vehicle when parked, select position **P** and apply the handbrake firmly. Check that the selector is in the **P** position to ensure that the driving wheels are locked.



- Never select position **N** if the vehicle is moving.
- Never select positions **P** or **R** if the vehicle is not completely stationary.

If, while the vehicle is moving, position **N** is engaged inadvertently, let the engine idle before engaging position **D** or **M**.



Reverse gear

Do not engage until the vehicle is stationary, foot on brake. To avoid engine hesitation, do not accelerate immediately after the selection.



Neutral

Do not select this position, even momentarily, when the vehicle is in motion.





DRIVING

CRUISE CONTROL

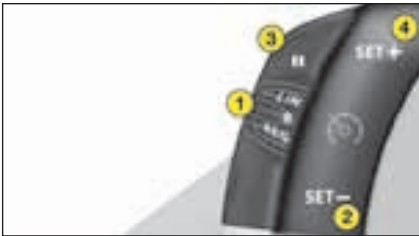

This driving assistance function allows you to drive at the speed of your choice without the need to action the accelerator.

This system is available above 40 km/h (25 mph), with 4th gear or higher on a manual gearbox or 2nd gear or higher on an automatic gearbox.

Note: Information relating to the cruise control is displayed in zone **A** of the instrument panel.

IX

To select the function

Turn control **1** to position "REG".

To select a cruising speed

At the time you select the function via the control **1**, there is no cruise speed previously memorised:



Accelerate to the desired speed, then press button **2** or button **4**. The cruise speed will then be memorised and displayed in zone **A** on the instrument panel.

Note: you can use successive presses to modify the cruise speed in steps of 1 mph and a continuous press to jump in steps of 5 mph.



You can then release the accelerator pedal. The vehicle will automatically keep to that chosen speed.

Note: The vehicle speed may vary slightly from that memorised.

To exceed the cruise speed temporarily

While cruise control is in use, it is always possible to go above the cruise speed simply by pressing the accelerator pedal (for example to overtake another vehicle). The speed displayed in zone **A** flashes.

You have only to release the accelerator pedal to return to your cruise speed.

Note: if during cruise control the system cannot keep to the cruise speed (e.g. on a steep descent), then the speed flashes. If necessary, brake to curb your speed.

Adjustment of the memorised speed while cruise control is in operation

To adjust the memorised speed, displayed in zone **A**, press on:

- button **4** to increase the speed,
- button **2** to decrease the speed.





DRIVING



Deactivation of cruise control with memorised speed

- Either by pressing the brake pedal or the clutch pedal.
- Or with a press on button **3**.
- Or when ESP or ASR is active.

Note: cruise control is disengaged when the gear lever is in neutral position.

These actions bring up the display **"OFF"** in zone **A** in the instrument panel.

These actions do not cancel your cruise speed which remains displayed on the instrument panel.



Reactivation of cruise control

- by recalling the memorised speed:

Following a deactivation, press on button **3**. Your vehicle automatically resumes the memorised cruise speed displayed in zone **A**.

- by selecting the current speed:

Press on button **2** or **4** as soon as the desired speed is reached. The information **"OFF"** will then disappear from zone **A**.

To cancel the function

- by moving the control from position **"REG"** to position **0**.
- by stopping the engine.

The cruise speed chosen previously is no longer memorised.

In the event of a malfunction, a message is displayed, accompanied by a sound signal and lighting of the **SERVICE** warning lamp.

Consult your **CITROËN** dealer.



Cruise control must only be used where road conditions permit driving at a constant speed.

Do not use it on congested roads or when weather and road conditions are poor.

The driver must still remain attentive and in complete control of the vehicle.

You are recommended to keep your feet within range of the pedals.

To avoid any interference with the pedals:

- ensure that any over-mats are correctly fitted,
- never superimpose one over-mat on another.





DRIVING

SPEED LIMITER



This driving assistance device allows you to select a maximum speed that you wish not to exceed. This has to be a speed greater than 30 km/h (approx. 20 mph).

The speed limiter controls are located on the steering wheel.

Note: The information relating to the limiter is displayed in zone A of the instrument panel.

IX

To select the function

Turn control 1 to position "LIM".

On selection of the function, the last speed memorised and the information "OFF" will appear:



To adjust the maximum speed

Provided the engine is running, you can adjust the memorised maximum speed, with short or long presses on:

- button 4 to increase the memorised maximum speed,
- button 2 to decrease the memorised maximum speed.

Note: successive presses modify the memorised speed in steps of 1 km/h (1 mph), a continuous press in steps of 5 km/h (3 mph).

Activation of the maximum speed

When the desired maximum speed is displayed, press button 3 to activate the limitation.

The information "OFF" then disappears from zone A.

While the function is active, pressing the accelerator pedal will not enable you to go beyond the programmed speed unless you press the pedal hard down past the tight spot (see "Temporary exceeding of the maximum speed").



Note: The vehicle speed may vary slightly from that memorised.





DRIVING



Deactivation of the maximum speed

Press button 3.

The information "OFF" will appear on the instrument panel screen.

This action does not cancel the memorised maximum speed, which remains displayed in zone A of the instrument panel.

Temporary override of the maximum speed

You can exceed the memorised maximum speed at any time by pressing the accelerator pedal hard down past the tight spot.

During the time the limit speed is being exceeded, the displayed speed flashes.

You have only to release the accelerator pedal to return below the maximum speed, thus keeping the function active.

Note: if during speed limitation, the system cannot keep to the maximum speed (especially on a steep descent or if you accelerate too hard) the speed flashes. Adapt your speed as necessary.

The function will re-engage when your speed has returned below the desired maximum.



To stop the function

- move the control from position "LIM" to position 0.
- or stop the engine.

The speed that you chose is memorised.

In the event of a malfunction, a message is displayed, accompanied by a sound signal and lighting of the SERVICE warning lamp.

Consult your CITROËN dealer.



A floor mat not recommended by CITROËN risks sliding under the accelerator pedal, thus preventing you from pressing past the tight spot.

It will then be impossible to exit from the desired limitation, unless by acting on the steering wheel control.

The driver must still remain attentive and in complete control of the vehicle.

We advise the driver to keep their feet close to the pedals.





DRIVING

VISUAL AND AUDIBLE FRONT AND REAR PARKING ASSISTANCE



Proximity sensors are located in the **front and rear bumpers** of your vehicle.

When manoeuvring, whether forwards or in reverse, at a speed below approx. 6 mph, they warn you of the presence of any obstacle situated within their detection zone, by means of:

- a sound signal emitted by the front or rear loudspeakers,
- the display of the outline of your vehicle with shading at the zones where obstacles are detected.

As the vehicle approaches an obstacle, the sound signal tells you its position according to whether the sound issues from the front LH or RH speaker or from the rear LH or RH speaker.



NaviDrive version



Screen C version

- As the vehicle gets close to the obstacle, the sound signal becomes ever more rapid and the shading appears ever closer to your vehicle's outline.
- When the obstacle is less than around 25 centimetres from the vehicle, the signal becomes continuous and a **WARNING** panel appears on the display.

Activation/Deactivation

You can activate/deactivate the parking assistance with a press on control 1. If the parking assistance is inactive, the warning lamp is on.

Activation or deactivation of the parking assistance is memorised when you stop the vehicle.

Note: The system is deactivated automatically if a trailer is attached to the vehicle.

The fitting of the towbar should be carried out by the CITROËN network.

This system does not replace the vigilance and responsibility of the driver.





DRIVING

Operation:

- **When you engage reverse gear**, a sound signal informs you that the system is active. The outline of your vehicle is displayed on the screen. Any obstacles situated at the rear or at the front of the vehicle can be detected.
- **Moving forward** at a speed lower than approx. 10 km/h (6 mph), either in neutral or in a gear, the outline of your vehicle is displayed on the screen immediately an obstacle is detected in front of the vehicle. Obstacles situated at the front of the vehicle can be detected.

Note

- The proximity sensors cannot detect obstacles situated immediately below or above the bumpers.
- A thin object such as a spike or stake, or other similar object, may be detected only at the start of your manoeuvre but not when the vehicle has approached close to it.
- During the winter months or in bad weather, make sure that the sensors are not covered by dirt or by ice or snow.



When selecting reverse gear, a short audible signal followed by another audible signal, accompanied by the illumination of the SERVICE warning lamp indicates a malfunction of the system. Consult a CITROËN dealer.





MAINTENANCE

BONNET RELEASE



This should only be operated if the vehicle is stationary.

To release the bonnet, pull control **A** located under the dashboard to the right.



Move the lever **A**, located above the grille, to the right of the chevrons, then lift.

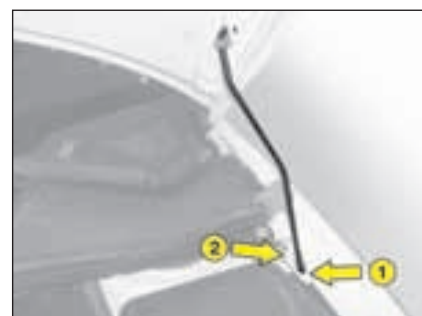

Bonnet stay: detach the stay and pivot to introduce it into the notch 1, then into the notch 2 (see the arrow reference).

Closing

Return the stay to its initial position, lower the bonnet and let it slam shut.

X

Make sure that the bonnet is securely locked.

Avoid operating the bonnet when there are high winds.





MAINTENANCE

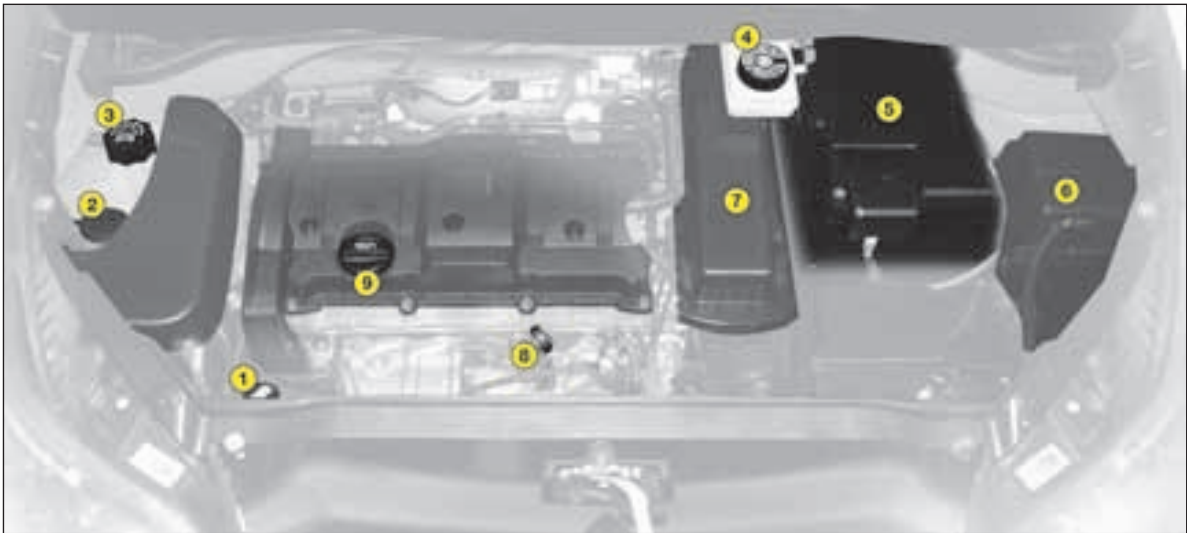

PETROL ENGINES

They give access for checking the levels of the various fluids and the replacement of certain items.

- | | | |
|--|---------------------------|---------------------------|
| 1. Power steering reservoir. | 4. Brake fluid reservoir. | 8. Engine oil dipstick. |
| 2. Screen and headlamp wash reservoir. | 5. Battery. | 9. Topping up engine oil. |
| 3. Engine coolant. | 6. Fusebox. | |
| | 7. Air filter*. | |

* Depending on engine.

X





MAINTENANCE

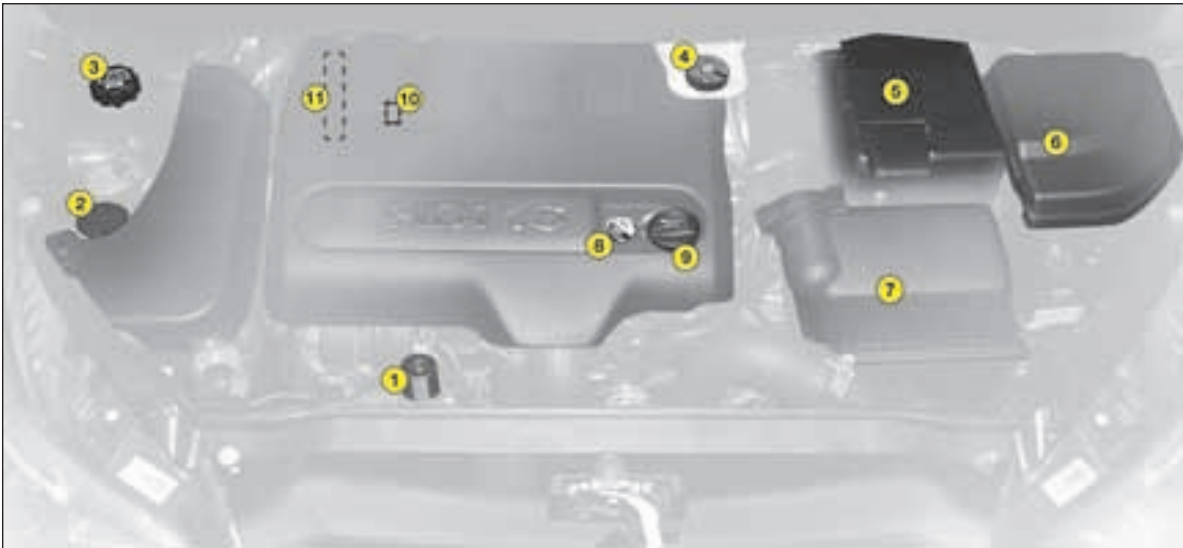

DIESEL ENGINES

They give access for checking the levels of the various fluids, the replacement of certain items and priming the fuel system.

X

- | | | |
|--|---------------------------|---------------------------|
| 1. Power steering reservoir. | 4. Brake fluid reservoir. | 9. Topping up engine oil. |
| 2. Screen and headlamp wash reservoir. | 5. Battery. | 10. Priming pump*. |
| 3. Engine coolant. | 6. Fusebox. | 11. Bleed screw*. |
| | 7. Air filter*. | |
| | 8. Engine oil dipstick. | |

* Depending on engine.





MAINTENANCE

LEVELS

Air filter

Follow the recommendations in the Maintenance Guide.



Windscreen, rear screen and headlamp washer fluid

It is recommended that you use products approved by CITROËN.

Screenwash fluid reservoir: 3.5 litres.

Screen and headlamp wash reservoir: 6.5 litres.

Specification for the fluid

To ensure optimum cleaning and to avoid freezing, topping up or filling of the reservoir must not be done with just water.



Engine coolant

The coolant level should be between the **MAX** and **MIN** marks on the header tank.

If the engine is hot, wait 15 minutes.

Quality: See "Maintenance Guide"

Never work on the cooling system if the engine is hot.



Engine oil

Check the oil level with the vehicle parked on level ground, after the engine has been switched off for at least fifteen minutes.

Quality: See "Maintenance Guide"



Take out the oil dipstick. The level must be between the **MAX** and **MIN** marks on the dipstick

It should never exceed the maximum mark.

MAX
MIN



Brake fluid

The fluid level must be situated within the **MAX** and **MIN** marks visible on the reservoir.

The screenwash fluid should be replaced periodically as it loses its effectiveness over time.

Quality: See "Maintenance Guide"

If the warning lamp comes on while you are driving, stop immediately and contact the CITROËN network.

Dust filter/odour filter (active carbon)

See "Maintenance Guide"



12 volt battery

See "Practical advice".



When working under the bonnet, when the engine is hot (even stopped and the ignition switched off), the cooling fan could operate at any time.

Check the engine oil level frequently between routine service visits, as well as prior to long journeys.





MAINTENANCE

LEVELS



Radiator - coolant

The coolant must only be checked or topped up if the power unit is cold.

Engine hot

As the cooling system is pressurised, wait for at least one hour after switching off the engine before intervening.

To avoid the risk of scalding, slacken the cap two turns to allow the pressure to escape. Once the pressure has fallen, remove the cap and top up the level.



Topping up the cooling system

The coolant level should be between the **MAX** and **MIN** marks on the header tank.

Top up the level. If you have to add more than **1** litre, you should have the cooling system checked by CITROËN.

Make sure that the cap is on correctly

Note: The necessity to top up frequently would indicate a malfunction that should be checked at the earliest opportunity.

Note: On vehicles equipped with a particle filter, the cooling fan may operate for some ten minutes after the engine has stopped.



Adding engine oil

Remove the dipstick before topping up. Check the level after filling.

It should never exceed the maximum mark.

Screw on the cap before closing the bonnet.

Quality: See "Maintenance Guide".

X





MAINTENANCE

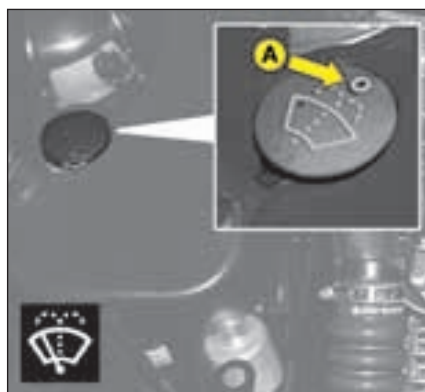

Windscreen and rear screen washer fluid

For best results as well as for your safety, use only CITROËN approved products which protect at temperatures as low as -25°C to -30°C .

It is essential to have sufficient screen wash fluid if your vehicle is equipped with Xenon headlamps.

To check the level, place a finger on aperture **A** before removing the cap.

Capacity: 3.5 litres.

Capacity with headlamp washers: 6.5 litres.



Brake fluid reservoir

Check and top up at regular intervals.

The fluid level must be situated within the **max** and **min** marks visible on the reservoir.

If the warning lamp comes on when driving, stop as quickly as possible and contact a CITROËN dealer.

Brake fluid

The synthetic fluid not only gives protection against corrosion but also ensures correct functioning of the braking system in all environmental conditions, therefore you should only use the synthetic product recommended by the CITROËN network. (this fluid must be replaced every two years).

These important requirements are detailed in your vehicle's Maintenance Guide.

Quality: See "Maintenance Guide".



When working under the bonnet, when the engine is hot (even stopped and the ignition switched off), the cooling fan could operate at any time.





MAINTENANCE

Wear of brake discs, brake pads and brake drums

The rate of wear of the brake pads depends on the use of your vehicle (urban use, frequent stops), and on your style of driving or the type of journey.

For information on checking the discs and drums for wear, contact a CITROËN dealer.

After washing the vehicle, brake progressively to dry out the brake linings.

DIESEL INJECTION EQUIPMENT

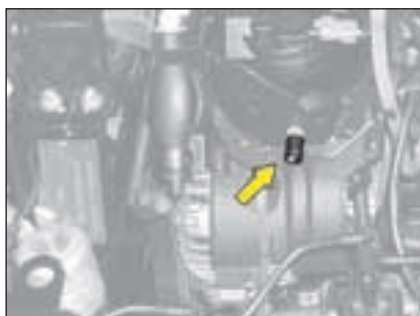

Bleeding of water from the diesel fuel filter

To be bled on a regular basis (at every oil change).

To evacuate the water, slacken the bleed screw or the water in diesel fuel sensor, which is located at the base of the filter, until water ceases to flow out.

Then retighten the bleed screw or the water in diesel fuel sensor.



Protection cover

HDi 135 and 140 engines

Remove the protection cover by first unclipping point 1, then 3 and 4. Detach point 2 by pulling towards you, then lift.

To reposition the protection cover, attach point 2 first. Lower the cover, keeping it centred. Clip points 1 and 4, pushing vertically and slightly rearwards. Clip point 3 pushing down vertically.

**HDi engines are of a highly technical nature.
All maintenance and repairs require specific qualifications
which only your CITROËN Dealer can guarantee.**





MAINTENANCE

PRIMING THE DIESEL FUEL SYSTEM



HDi 135 and 140 engines

Detach the protection cover to access the priming pump.



HDi 90 and 110 engines

Detach the protection cover to access the priming pump.

In the event of running out of fuel:

- After filling (5 litres minimum), operate the manual priming pump until some resistance is felt.
- Operate the starter motor while depressing the accelerator pedal slightly until the engine starts.

If the engine fails to start at the first attempt, wait 15 seconds before trying again.

If the engine fails to start after several attempts, repeat the procedure from the beginning.

When the engine is idling, accelerate slightly to complete the bleeding of the circuit.

X

**HDi engines are of a highly technical nature.
All maintenance and repairs require specific qualifications which only your CITROËN Dealer can guarantee.**

123





PRACTICAL ADVICE

FUEL



A label on the inside of the fuel filler flap indicates the approved fuel quality type.



DIESEL FUEL

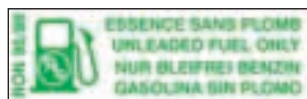

UNLEADED PETROL

XI

Petrol engines are designed to run on RON 95 fuel.

However, for better vehicle performance (petrol engines), we recommend RON 98.

For petrol engines with catalytic converter, use of unleaded fuel is obligatory

The filler neck has a narrower orifice to admit only petrol filler nozzles.

When you are filling your fuel tank, do not persist after the third cutoff; this could cause your vehicle to malfunction.

BioFlex

Your vehicle has been designed to operate **equally** on unleaded petrol (95 or 98) or on bioethanol (in Europe this is a mixture of 85 % ethanol and 15 % unleaded petrol, known as **E85**).

A label inside the fuel filler flap indicates the fuels authorised:



Other than the question of the two authorised fuels, your vehicle is used in the same way as a traditional petrol vehicle.



If you have put in fuel that is wrong for your vehicle, it is essential to have the tank drained before you start the engine.

In winter conditions, starting from cold may seem difficult. During periods of very cold weather we recommend the use of 95 or 98 unleaded petrol in preference to B85 so as to ensure optimum starting performance.





PRACTICAL ADVICE

CHANGING A WHEEL



Access to the spare wheel

Lift the boot floor.

Dimension of the spare wheel

If your spare wheel is of a different dimension to those on the vehicle (identified by a label), it is essential to use it only on a temporary basis, to drive not above 80 km/h (50 mph) and to have the original wheel refitted as soon as possible.

Tyre pressures

This is indicated on a label in the front door aperture.

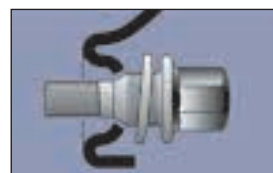

Light alloy wheels

If your vehicle is equipped with light alloy wheels and a steel spare wheel, then if fitting the latter it is normal to note that the heads of the wheel bolts do not come to bear on the wheel rim.

The steel spare wheel is secured by the conical tapering of the wheel bolts' shafts, see diagram.

When refitting the light alloy wheel, ensure that the wheel bolt heads are in undamaged condition.

Switch on your hazard warning lamps.

Never get underneath the vehicle if it is supported only by the jack; use an axle stand.

The jack is designed specifically for your vehicle, do not use it for other applications.

**Refit the repaired original wheel as soon as possible.
With a spare wheel fitted, drive with caution.**





PRACTICAL ADVICE

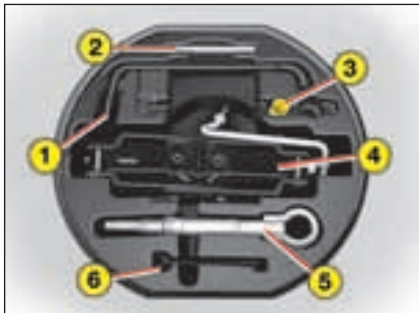

Tools

The tools are located in a protective holder in the spare wheel, remove the strap to gain access.

- 1 - Wheelbrace
- 2 - Centring guide
- 3 - Tool for removing/refitting wheel bolts
- 4 - Jack with handle
- 5 - Removable towing ring
- 6 - Tool for bolt protectors on aluminium wheels



Removing the wheel

- Undo the yellow central screw by a quarter turn.
- Raise the spare wheel towards you rearwards.
- Remove the wheel from the boot space.



Repositioning the wheel

- Refit the wheel in place.
- Undo the yellow central screw by a few turns, then position it at the centre of the wheel.
- Do up the central screw until tight so that the wheel is securely retained in place.

The wheel should be correctly positioned flat in the centre of its well.





PRACTICAL ADVICE



Removal

- 1 - Park the vehicle on stable, firm ground. Apply the handbrake. Switch off the ignition and engage first gear or reverse gear, depending on any slope (for vehicles with automatic gearbox, select position P).
- 2 - Detach the embellisher using the wheelbrace **1** by pulling close to the valve.
For vehicles with aluminium wheel rims, slide the removal tool **6** into the slot in the central embellisher and apply firm leverage to detach.
- 3 - Slacken the wheel bolts.
For vehicles with aluminium wheels, slacken the anti-theft nut using the tool provided.



- 4 - Position the jack under the bodyshell, exactly as in the illustration, at the mark **A** (in the recess in the sill member) closest to the wheel that is to be replaced.
- 5 - Deploy the jack **4** until its base is in contact with the ground. Make sure that the base of the jack is vertically below the jacking point used.
- 6 - Raise the vehicle.
- 7 - Remove the bolts and disengage the wheel.

Make absolutely sure that the occupants have left the vehicle and are in an area that ensures their safety.



Refitting

- 1 - Position the wheel with the aid of the centring guide.
- 2 - Do up the 3 bolts by hand and remove the centring guide. Position the 4th bolt.
- 3 - Do pre-tightening with the wheelbrace **1**.
- 4 - Retract the jack **4** and disengage it.
- 5 - Tighten the wheel bolts using the wheelbrace **1**.
- 6 - Reposition the embellisher, commencing by placing the slot at the valve, pressing it home with the palm of your hand. For vehicles with aluminium wheels, refit the bolt protector.
- 7 - Stow the tools and the wheel in the boot.
- 8 - Check the tyre pressure and also have its balancing checked.

XI





PRACTICAL ADVICE

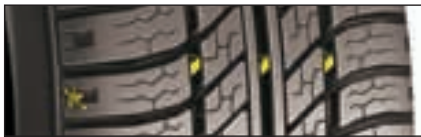

Wear indicators

Check the tread depth frequently.

Minimum legal depth: 1.6 mm.

Check the wear indicators and the tread depth regularly as worn tyres have reduced grip. The wear indicators show when a tyre is at its safe wear limit.



Under-inflated tyres can overheat, leading to structural damage and the risk of a blow-out.

Impacts with kerbs, potholes or hidden obstructions in the road can cause internal damage and premature failure of the tyre. Such impacts can also cause misalignment of the steering geometry and subsequent rapid tyre wear.

Advice

We therefore recommend that you have the tyres and suspension geometries checked after any such incidents.

Prolonged driving on poor surfaces may be the cause of damage which may only become evident at a later date.

If replacing your tyres, it is essential to use the tyre sizes that are recommended for your vehicle.

Contact a CITROËN dealer.

Inspect the tyres regularly for wear and damage such as cuts, cracks or bulges, etc.

Remove any foreign bodies (stones, pieces of metal) that may have pierced the tyre. They could cause further damage to the tyre carcass.

Correctly inflated tyres provide:

- Optimum roadholding.
- Precise, light steering.
- Improved fuel economy.
- Increased tyre life.

Use the tyre pressures recommended by CITROËN.

Check the tyre pressures when the tyres are cold, on a frequent basis.

Never reduce the pressure of a hot tyre

Puncture

A punctured tyre should always be removed from the rim and thoroughly examined for any secondary damage before attempting any repair. When a repair is possible, it should be carried out as soon as possible to prevent further damage to the tyre.

Tyre repair should be carried out by a tyre specialist who will assume responsibility for the repair.

XI



On slippery surfaces, drive prudently.

Make sure that all 4 tyres are always in good condition and that the tyre pressures (including for the spare wheel) are always set correctly.

128





PRACTICAL ADVICE

REPLACING BULBS



FRONT LAMPS

- ❶ Headlamp dipped beam
- ❷ Main beam
- ❸ Sidelamp
- ❹ Direction indicator

Note: A light mist film can appear on the internal surface of the headlamp lens in certain climatic conditions (low temperature, humidity). This disappears within a few minutes of switching on the headlamps.

Note: If it should be necessary to access the front RH headlamp, remove the cover by pressing the 2 clips.



FRONT LAMPS, DIRECTIONAL HEADLAMPS

- ❶ Additional headlamp (main beam)
- ❷ Headlamp dipped beam/ Main beam
- ❸ Sidelamp
- ❹ Direction indicator



The halogen bulbs should not be changed until they have been off for a few minutes (risk of serious burns).

Do not touch the new bulb directly with your fingers; use a lint-free cloth.

It is essential that only anti U.V. type bulbs are used in order not to damage the headlamp.

When using a high-pressure jet wash for cleaning the vehicle, don't persist on the headlamps and other lamps, particularly around their edges, so as to avoid damaging their lacquer finish or seals.



If the headlamp has this symbol, any operation involving changing a Xenon D1S bulb must be carried out by the CITROËN network (risk of electrocution).

It is recommended to change both bulbs at the same time if one is faulty.

XI





PRACTICAL ADVICE



Main beam

Pull the rubber stops.
Disconnect the bulb.
Disengage the ends of the retaining spring to release it.
Remove the bulb.

Bulb: H1 For vehicles not equipped with Xenon headlamp bulbs.



Headlamp dipped beam

Pull the rubber stops.
Disconnect the bulb.
Disengage the ends of the retaining spring to release it.
Remove the bulb.

Bulb: H7

Note: On HDi 90 and 110 engines, unclip the cover for access to the left hand headlamp.





PRACTICAL ADVICE

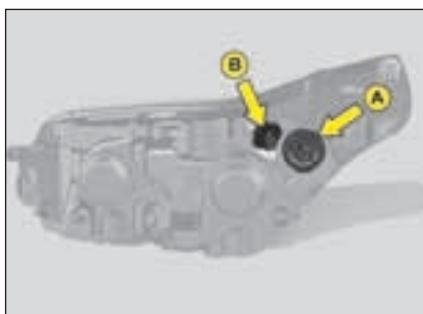

Front lamps

Front direction indicator

Rotate the bulb-holder **A** by a quarter turn and pull.

Press to disengage the bulb.

Bulb: PY 21 W yellow.

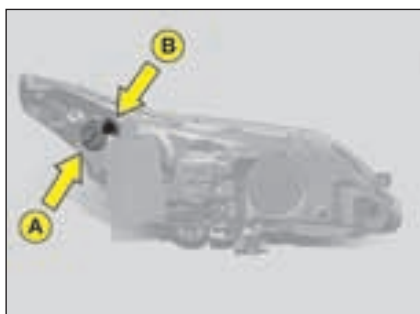

Front lamps, directional headlamps

Sidelamp

Disconnect the connector by pressing on the metallic part.

Rotate the bulb-holder **B** by a quarter turn and pull on the bulb.

Bulb: W 5.



Direction indicator side repeaters in the rear view mirrors

To change the side repeater bulb, press firmly in the area indicated by the arrow, then pull on the side repeater.



Front foglamps

Consult your CITROËN dealer.

XI





PRACTICAL ADVICE



Interior lamp

Unclip the transparent cover of the interior lamp to reach the bulb.

Bulb: W 5 W

Spotlamps

Unclip the cover of the interior lamp, then if necessary the partition for the spotlamp concerned, to access the bulb.

Bulb: W 5 W



Boot lighting

Unclip the lens unit to access the bulb.

Bulb: W 5 W



Glovebox lighting

Unclip the lens unit to access the bulb.

Bulb: W 5 W



Sill lighting

Unclip the headlamp to access the bulb.

Bulb: W 5 W





PRACTICAL ADVICE



REAR LAMPS (5-door model)

Identify the failed bulb.

Bulbs:

- ❶ Sidelamp: W 5.
- ❷ Stop lamps and sidelamps: P21/5.
- ❸ Direction indicator: PY 21 W.



Removal

Open the boot:

- First remove the top part of the rear lamp unit by undoing the screw **A**.
- To have access to the nut **B**, detach the boot rear trim by removing the pins. Undo **B**.
- Remove the bottom part of the lamp unit.
- To change a bulb, simply rotate it a quarter turn.



Third stop lamp

Consult your CITROËN dealer.





PRACTICAL ADVICE



REAR LAMPS (3-door model)

Identify the failed bulb.

Bulbs:

- ❶ **Direction indicator:** P21 W.
- ❷ **Reversing lamp:** P21 W.
- ❸ **Stop lamps and sidelamps:** P21/5.

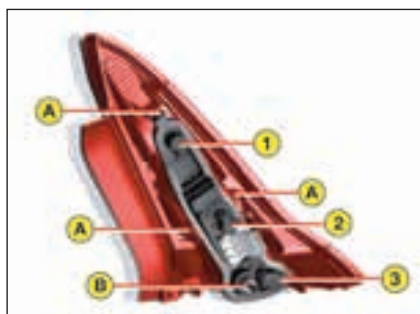

Removal

To have access to the nut **B**, detach the boot rear trim by removing the pins. Undo **B**.

Remove the bulb-holder by detaching the points **A**.

Disengage the lamp unit.

To change a bulb, rotate it a quarter turn.



Third stop lamp

Consult your CITROËN dealer.





PRACTICAL ADVICE



Rear number plate lamp

- Insert a thin screwdriver into one of the holes on the outside of the plastic cover.
- Push outwards.
- Remove the plastic cover.
- Replace the faulty bulb by simply pulling it out.

Bulb: W 5 W.

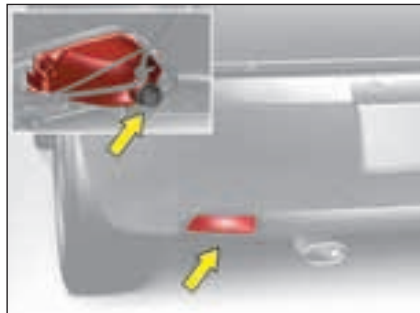

Foglamp

Rotate the bulb-holder a quarter turn.

Bulb: P21



Reversing lamp (5-door model)

Rotate the bulb-holder a quarter turn.

Bulb: P21

XI

After replacing a bulb, check the correct operation of the lighting and signalling.

135





PRACTICAL ADVICE

REPLACING A FUSE

Fuse box

There are two fuse boxes, one below the dashboard and one under the bonnet.

Fuses under the dashboard

To access the fuses below the dashboard, pull back the access cover, undo the screws a quarter turn and tilt the whole unit.

Replacing a fuse

Before replacing a fuse, it is essential to find the cause of the incident and to rectify it. The fuse identification numbers are indicated inside the fuse box.

Replace a blown fuse with one of the same rating (the same colour)

Use the special pliers **A** stowed on the cover close to the fuseboxes, this includes a compartment for replacement fuses.

Good



Faulty



Tool A

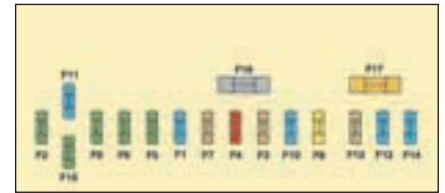
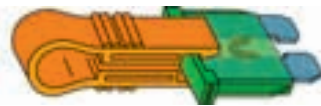

Fuses under the dashboard



Access to the first fusebox under the dashboard

Your vehicle's electrical system is designed to operate with standard or optional equipment.

Before installing other electrical equipment or accessories in your vehicle, contact a CITROËN dealer.

CITROËN will not accept responsibility for the cost incurred in repairing your vehicle or for rectifying the malfunctions resulting from the installation of accessories not supplied and not recommended by CITROËN and not installed in accordance with its instructions, in particular when the consumption of all of the additional equipment connected exceeds 10 milliamperes.





PRACTICAL ADVICE

FUSES UNDER THE DASHBOARD

Fuse N°	Rating	Functions
F1	15 A	Central locking
F2	30 A	Central locking - Deadlocking
F3	5 A	Airbags and pretensioners
F4	10 A	Diagnostic socket - Brake switch - Photochromic rear view mirror - ESP - Coolant level sensor - Diesel fuel additive system - Power steering Clutch pedal switch (ESP, cruise control and speed limiter)
F5	30 A	Electric front windows - Heated exterior rear view mirrors
F6	30 A	Electric rear windows
F7	5 A	Interior lighting
F8	20 A	Audio system - NaviDrive - Display - Alarm - Front 12 V socket - Trailer relay unit - Driving school module
F9	30 A	Cigar lighter - Rear 12 V socket
F10	15 A	Tyre pressure sensor - Auto. gearbox - STOPLAMP switch
F11	15 A	Ignition - Diagnostic socket - Particle filter
F12	15 A	Electric seat - Lane wandering alert - Parking assistance
F13	5 A	Rain sensor - Sunlight sensor - (6 speed) Electronic Gearbox System - Engine relay unit
F14	15 A	Air conditioning - Instrument panel - Tachometer - Airbags and pretensioners - Trailer relay unit - Bluetooth telephone
F15	30 A	Central locking - Deadlocking
F16	SHUNT	
F17	40 A	Heated rear screen

XI

137





PRACTICAL ADVICE

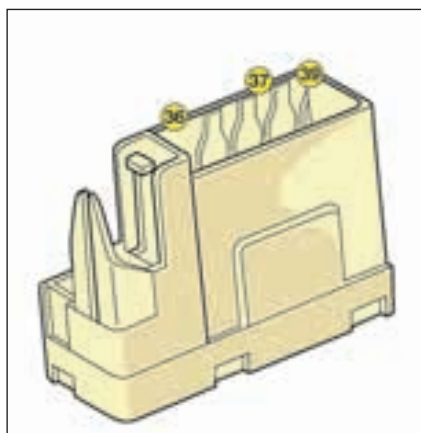
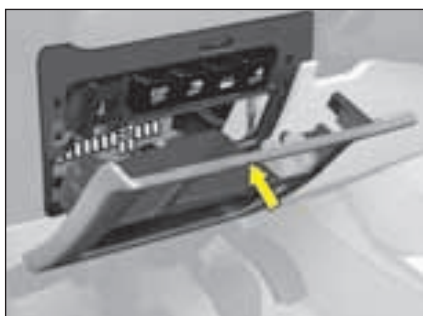

Fuse box

Fuse N°	Rating	Functions
F36	30 A	Hi Fi amplifier
F37	30 A	Driver's electric seat
F39	20 A	Heated seats

XI





PRACTICAL ADVICE



Fuse box

To access the engine compartment fusebox, detach and remove the cover.

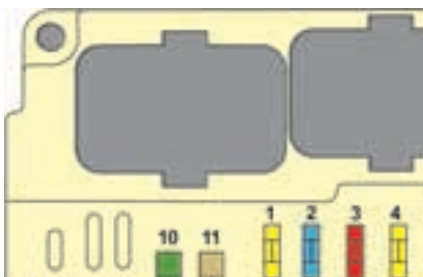

After any repair, reclose the cover very carefully. If the cover is not correctly positioned or not properly closed, your vehicle could be subject to serious malfunctions. For the same reason, take the utmost care not to spill any liquids.

FUSES UNDER THE BONNET

Fuse N°	Rating	Functions
F1	20 A	ECU engine management - Cooling fan
F2	15 A	Horn
F3	10 A	Windscreen and rear screen wash
F4	20 A	Headlamp washer
F5	15 A	Fuel pump
F6	10 A	Auto. gearbox - Xenon lamps - Directional headlamps - Canister purge electrovalve
F7	10 A	ABS ECU/ESP ECU - Power steering
F8	25 A	Starter
F9	10 A	Additional heating control unit (Diesel) - Engine coolant level switch

Only authorised personnel from the CITROËN network are allowed to carry out any work on the additional protection MAXI fuses located in the fuse boxes.

XI

139





PRACTICAL ADVICE

FUSES UNDER THE BONNET

Fuse N°	Rating	Functions
F10	30 A	Engine electrovalve - Water-in-diesel-fuel sensor - ECU engine management - Injectors - Ignition coil - Oxygen sensor - Canister purge electrovalve (1.4 16V and 1.6 16V engines)
F11	40 A	Air blower - Air conditioning
F12	30 A	Windscreen wiper
F13	40 A	Built-in Systems Interface
F14	-	Not used
F15	10 A	Right hand main beam
F16	10 A	Left hand main beam
F17	15 A	Left hand dipped beam
F18	15 A	Right and dipped beam
F19	15 A	Engine management ECU (1.4i 16V and 1.6i 16V engines)
F20	20 A	Engine electrovalves
F21	5 A	Cooling fans relay - Valvetronic

XI





PRACTICAL ADVICE

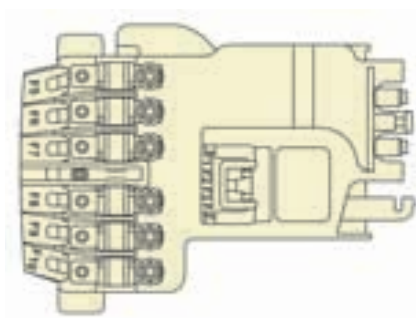

FUSES UNDER THE BATTERY

Fusible N°	Intensité	Fonctions
F1	-	Not used
F2*	30 A	Gearbox (electronic or automatic)
F3	-	Not used
F4	-	Not used
F5*	80 A	Power steering electro-pump unit
F6*	70 A	Heater unit (Diesel)
F7*	100 A	Switching and protection unit
F8	-	Not used
F9*	30 A	Electronic gearbox electro-pump unit
F10*	30 A	Valvetronic electronic motor

MAXI-FUSES

Fuse N°	Rating	Functions
MF1*	30 A/50 A	
MF2*	30 A	ABS/ESP pump supply
MF3*	50 A	ABS/ESP ECU
MF4*	80 A	Built-in Systems Interface
MF5*	80 A	Built-in Systems Interface
MF6*	80 A	Cabin fusebox
MF7*	20 A	Diagnostic socket/FAP additive pump
MF8*	-	Not used

* The maxi-fuses are an additional protection for the electrical systems. All work on the maxi-fuses must be done by a CITROËN dealer.

XI





PRACTICAL ADVICE

BATTERY

Removal

If the vehicle is fitted with an alarm, this should be deactivated before disconnecting the battery.

Disconnect the battery leads, negative lead first.

Refitting

Ensure that the battery is correctly positioned.

On certain models, the flange should be midway between the two battery terminals.

Reconnect the battery starting with the positive lead first.

Precautions

- Ensure that the posts and terminals are clean.
- If they become sulphated (white deposit), disconnect and clean them.
- Never disconnect the leads while the engine is running.
- Never recharge the battery without first disconnecting the battery leads.

Recharging using a battery charger

The voltage must never exceed 15.5 volts and the charging current must never exceed 20 % of the rating marked on the battery casing (for example: 250 A, setting: 50 A maximum).

Length of charge: 24 hours maximum.

Only battery chargers with a constant, regulated voltage output should be used.

If the vehicle is not in use for a prolonged period

If the vehicle is to be taken out of use for periods of more than one month, the battery should be disconnected.



If a metal object makes a contact between the two battery terminals or between the battery + and the bodywork, this causes a short-circuit (risk of fire and serious burns).

The battery releases minute quantities of hydrogen, a gas which is explosive under certain conditions. Never use a flame or create sparks close to the battery.

The battery contains dilute sulphuric acid which is highly corrosive:

- **When handling batteries, always protect your face and especially your eyes.**
- **In the event of any contact with the skin, rinse immediately with copious amounts of fresh water.**

Refer to a CITROËN dealer for battery replacements.





PRACTICAL ADVICE

Access to the battery

The battery is located in the engine compartment.

For access to it:

- open the bonnet using the interior release lever, then the exterior safety catch,
- fix the bonnet stay in place,
- remove the plastic cover for access to the two terminals,
- if necessary, unclip the fusebox to remove the battery.

Emergency starting with a slave battery

A vehicle with a discharged battery can be started with either a slave battery or the battery of another vehicle.

A Discharged battery

B Slave battery

It is essential to proceed strictly following the **sequence** indicated.

Check that the emergency battery is correctly charged up (12 volts).

If you are using the battery on another vehicle, stop the engine of the assisting vehicle. The two vehicles must not come into direct contact with each other.

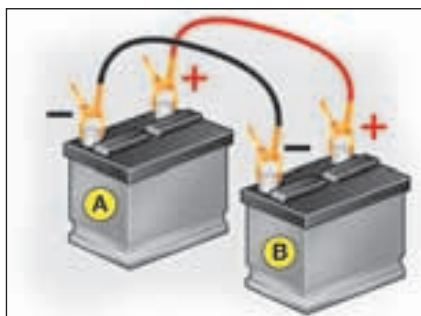

Connect the cables in the **order** indicated in the diagram. Make sure that the clamps are properly secured (risk of sparks).

Start the engine of the assisting vehicle. Let the engine run for about a minute at a slightly accelerated speed.

Start the engine of the assisted vehicle.

Note: For any repair necessitating a disconnection of the battery, it is essential to wait three minutes after switching off the ignition and to avoid any action that could prevent the vehicle's electrical circuit from changing to standby mode (such as opening and closing doors, using the remote control etc.).



Advice

Replace it with a battery of the same type (voltage, amp rating).

Do not touch the cable clamps during the procedure.

Do not lean over the batteries.

Disconnect the cables in the reverse order to connection, ensuring that they do not touch each other.



Never apply a flame or create sparks close to the battery (explosive gas).

The battery contains diluted sulphuric acid which is highly corrosive.

If ever you are handling the battery, protect your eyes and face.

In the event of any contact with the skin, rinse immediately with copious amounts of fresh water.

If the vehicle is not used for more than one month, it is recommended that the battery be disconnected.

XI





PRACTICAL ADVICE

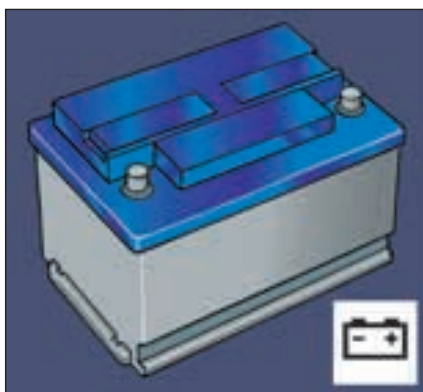

Before disconnection

Before disconnecting the battery, wait 3 minutes after switching off the ignition, and close the windows and doors.

After disconnection

After the battery has been disconnected for a long period, it may be necessary to re-initialise the following functions:

- Anti-pinch and sequential operation on the electric windows.
- Parameters of the multifunction display (date, time, language, units of distance and temperature).
- Radio stations.
- Navigation reception.
- Synchronisation of remote control.
- Central locking.

Certain adjustments will be cancelled: it is necessary to make them again.

Starting the engine for the first time after disconnecting and connecting the battery:

- Turn the ignition key.
- Wait approx. one minute before actioning the starter, so as to allow the electronic systems to reinitialise.

Economy mode

In order not to discharge the battery when the engine is stopped, your vehicle goes automatically into economy mode.

The electrical components relating to comfort and headlamps (not sidelamps or hazard warning lamps) are automatically cut.

To reactivate them, the engine must be run for:

- less than 10 minutes to have the systems available for an equivalent period.
- more than 10 minutes to keep them available for approximately 30 minutes.

Note: a starting economy mode message appears on the multifunction screen.





PRACTICAL ADVICE

TOWING

Towing (boat, caravan, etc.)

Before departure:

Check the tyre pressures of both car and trailer.

Check all the exterior and signalling lamps of the car and trailer.

Practice manoeuvring, especially reversing.

Grease the towing ball hitch regularly, and remove it when not towing for a long period.

Spread the load inside the caravan and keep within the towing weight limits.

Always drive at moderate speeds, changing down a gear in good time before hill climbs or descents. Be aware of the effect of side winds.

Braking distances are increased. Use the brakes gently and progressively. Avoid sudden braking.

If you have to park on an incline, make sure that the parking brake is firmly applied. Check that the tow hitch is firmly attached and, if necessary, chock the wheels of the trailer.

When towing, the fuel consumption will increase.

Towing a vehicle

If you are towing another vehicle, the latter should be out of gear (gearbox in neutral). Move the gear lever to neutral (position N for SensoDrive and automatic gearboxes).

Observe your vehicle's towing limits

It is essential to comply with the max. Gross Trailer Weights and speed limits as specified by legislation in each country.

For further information about the towing capacity of your vehicle and its max. authorised Gross Train Weight, contact a CITROËN dealer

Removable towing ring

The towing ring is detachable and can be fitted either at the front or at the rear of the vehicle. It is stowed in the jack's protective holder in the spare wheel.



Advice

In exceptional circumstances, it is permitted to tow the vehicle **at low speed over a short distance** (in accordance with the local legislation in force).

In all other cases, the vehicle must be transported by a transporter.

CAUTION - TOWING A VEHICLE WITH AUTOMATIC TRANSMISSION

Put the selector lever in position N (neutral).





PRACTICAL ADVICE



Towing with all wheels on the ground

Towing ring fixings are placed at the front and at the rear of the vehicle.

To access them:

- at the front: push on the left to tilt the cover, then remove it.
- at the rear: push at bottom, then pull on top.

The cover remains attached to the bumper by means of a tab, so that it cannot become lost.

The ignition key should be in position "M" so as to retain steering.

Use a bar with hooks to attach on the towing rings.

Vehicles with manual transmission

For vehicles with manual transmission, the gear lever must be in neutral. Failure to observe this requirement can lead to the failure of certain braking components and a lack of braking assistance on restarting the engine.



If the engine is not running, the steering and braking systems will not be power-assisted.

If towing another vehicle, the latter should be free-wheeling (that is, gearbox in neutral).





PRACTICAL ADVICE

TOWBAR

We recommend you to have this device fitted by a CITROËN Dealer, who will be acquainted with your vehicle's towing capability and with the procedures necessary for installing a safety item of this kind.

It is essential to install a CITROËN approved electronic unit when having a towbar fitted, in order to prevent any risk of malfunction or damage (risk of fire).

The fitting of a caravan mirror on the wing is prohibited.



dimensions in metres: **A** = 0.841

**Respect the towing limits
of your vehicle.**





PRACTICAL ADVICE

COLD WEATHER SCREEN "SNOW GUARD"

The screen supplied with the vehicle (depending on country) should be fitted during the winter period. It is essential to remove it when temperatures are above 10 degrees Celsius.

Don't forget to remove the cold weather screen:

- when the ambient temperature is above 10 °C,
- when towing,
- for speeds above 120 km/h (75 mph).

RADIO PRE-EQUIPMENT



CITROËN radio option

See the separate instruction booklet in the vehicle document pack.

Radio connections

Consult your CITROËN dealer



Fitting of front and rear loudspeakers

Consult your CITROËN dealer



On the dashboard

Two tweeters located at each end of the dashboard. Detach and pull the grille, connect the tweeters, fit them on the grille, rotating them a quarter turn, reposition the grilles.

XI





PRACTICAL ADVICE

ACCESSORIES

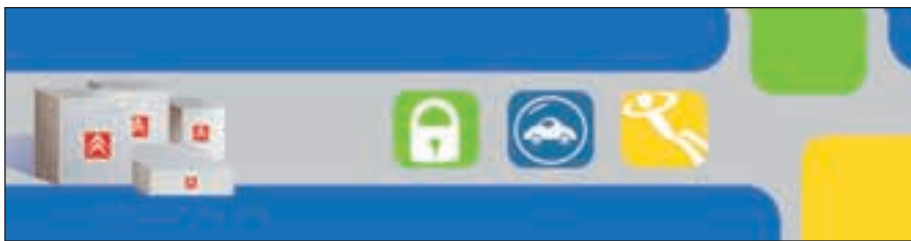

A wide range of CITROËN replacement parts and accessories is available from the dealer network.

They are all from the CITROËN catalogue.

After being tested for reliability and safety, these parts and accessories are all adapted for your CITROËN vehicle.

The range is structured around 5 groups:

"Security and safety": anti-intrusion alarm, first aid kit, warning triangle, high visibility vest, snow chains and anti-slip covers, front foglamp kit, rear parking assistance...

"Comfort and leisure": floor mats, boot protector, storage box under rear shelf, sun blinds, roof bars, arm rest, telephone carrier, child seats and booster cushions, air freshener cartridges...

To avoid any interference with the pedals:

- ensure that any over-mats are correctly fitted,
- never superimpose one over-mat on another.

"Navigation and communication": Bluetooth® hands-free kit, radios, portable navigation systems, CD changer, auxiliary cable for radio (e.g. connection between MP3 player and radio), speakers...

"Personalisation": seat covers, 15 and 17 inch light alloy wheel rims, wheel embellishers, standard mudflaps, style mudflaps, door deflectors, door aperture protectors, aluminium interior trim kit, door handle protectors...

"Boutique": screenwash fluid, cleaning and maintenance products for interior and exterior...



The fitting of electrical equipment or accessories that are not recommended by CITROËN may result in a failure of your vehicle's electronic system or excessive current consumption.

Please note this specific warning. It is advisable to contact a CITROËN dealer to be shown the recommended equipment and accessories.





PRACTICAL ADVICE

Roof bars and roof boxes

The design of your vehicle is such that for your safety and to avoid damaging the roof and tailgate you should use roof bars and roof boxes that have been tested and approved by AUTOMOBILES CITROËN.

Recommendations

- Spread the load uniformly, taking care not to overload one side.
- Place the heaviest load as close as possible to the roof.
- Fix the load securely and attach warnings if the load is large.
- Drive gently, sensitivity to side winds is increased (the stability of your vehicle may be affected).
- Remove the roof bars when no longer needed.

Bicycle carrier

The installation of a bicycle carrier on the tailgate of 3 door models is prohibited.

Respect the authorised load capacity.

C4 ENTERPRISE

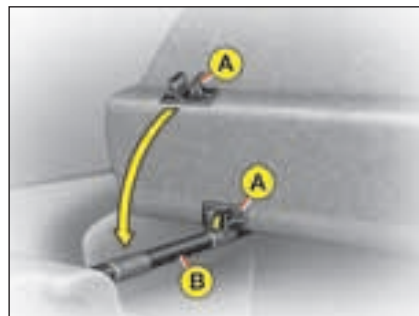

Luggage cover

This conceals the interior of the vehicle in combination with your rear shelf.

Installation

Take care to insert the fixings **A** on the frame **B**.



Stowage

To access the load area roll up the luggage cover.

Removal

It is possible to remove the luggage cover entirely.

Do not place hard or heavy objects on the luggage cover. They could become dangerous projectiles in the event of sudden braking or a collision.

XI

150





TECHNICAL SPECIFICATIONS

CAPACITIES

Engine type	Engine oil capacity in litres ⁽¹⁾
1.4i 16V - 65 kW	3.15
1.6i 16V - 80 kW	3.35
1.6i 16V - 88 kW	-
1.6i 16V - 110 kW	-
1.6i 16V - 103 kW	-
HDi 66 kW (90 hp)	3.85
HDi 80 kW (110 hp)	3.85
HDi 100 kW (135 hp)	5.3
HDi 103 kW (140 hp)	5.3

ENGINE TABLES LEGEND

BVM: Manual gearbox.

BVMP: (6 speed) Electronic Gearbox System.

BVA: Automatic gearbox.

FAP: Diesel particulate filter system (DPFS).

"Michelin Energy Saver": tyres with very low rolling resistance. This tyre equipment contributes to the protection of the environment and the reduction of your vehicle's fuel consumption.

BioFlex: A vehicle fitted with a BioFlex engine can operate equally on unleaded petrol (95/98) or on bioethanol (See "Fuel").

Observe your vehicle's towing limits.

It is essential to comply with the max. Gross Trailer Weights and speed limits as specified by legislation in each country. For further information about the towing capacity of your vehicle and its max. authorised Gross Train Weight, contact your CITROËN dealer.

(1) After an oil change with filter change





TECHNICAL SPECIFICATIONS

WEIGHTS - PETROL

Engine type	5-door model									
	1.4i 16V BVM	1.6i 16V BVM	1.6i 16V BVA	1.6i 16V 120 ch BVM	1.6i 16V 120 ch BVA	1.6i 16V 150 ch BVM	1.6i 16V 140 ch BVA	1.6i 16V manual BioFlex		
Fuel tank capacity	Approximately 60 litres									
Recommended fuel	Unleaded petrol RON 95 - RON 98								E85	
Turning circle between walls (in metres)	11.3	11.3	11.3	11.3	11.3	11.3	11.3	11.3	-	
French fiscal rating	6	7	7	7	7	9	9	7		
Power (kW)	65	80	80	88	88	110	103	80	-	
Calculated maximum speed in km/h (mph) (in the highest gear)	182	194	188	-	-	-	-	194	-	
Weights (kg)										
Unladen weight	1 182	1 200	1 274	1 220	1 273	1 276	1 290	1 200	-	
Gross vehicle weight (GVW)	1 702	1 732	1 794	1 731	1 761	1 763	1 776	1 732	-	
Maximum rear axle weight	850	850	850	910	910	920	910	850	-	
Gross train weight (GTW)	2 902	2 932	2 994	3 031	3 031	3 163	3 076	2 932	-	
Gross trailer weight (with brakes) (within the Gross Train Weight limit)										
10 to 12 % incline	1 200	1 200	1 200	1 300	1 270	1 400	1 300	1 200	-	
8 to 10 % incline	1 200	1 200	1 200	1 300	1 270	1 400	1 300	1 200	-	
Incline of up to 8 %	1 500	1 400	1 400	1 400	1 300	1 500	1 350	1 400	-	
Gross trailer weight (without brakes)	628	637	674	645	670	645	680	637	-	
Trailer nose weight	63	61	62	65	65	70	70	61	-	
Maximum roof bar load	75									

XII

152





TECHNICAL SPECIFICATIONS

WEIGHTS - PETROL

Engine type	3-door model							1.6i 16V manual BioFlex
	1.4i 16V BVM	1.6i 16V BVM	1.6i 16V BVA	1.6i 16V 120 ch BVM	1.6i 16V 120 ch BVA	1.6i 16V 150 ch BVM		
Fuel tank capacity	Approximately 60 litres							
Recommended fuel	Unleaded petrol RON 95 - RON 98							E85
Turning circle between walls (in metres)	11.3	11.3	11.3	11.3	11.3	11.3	11.3	-
French fiscal rating	6	7	7	7	7	9	7	
Power (kW)	65	80	80	88	88	110	80	-
Calculated maximum speed in km/h (mph) (in the highest gear)	182	194	188	-	-	-	194	-
Weights (kg)								
Unladen weight	1 181	1 200	1 278	1 217	1 273	1 271	1 200	-
Gross vehicle weight (GVW)	1 701	1 720	1 798	1 727	1 757	1 754	1 720	-
Maximum rear axle weight	850	850	850	910	900	910	850	-
Gross train weight (GTW)	2 901	2 920	2 998	3 027	3 027	3 154	2 920	-
Gross trailer weight (with brakes) (within the Gross Train Weight limit)								
10 to 12 % incline	1 200	1 200	1 200	1 300	1 270	1 400	1 200	-
8 to 10 % incline	1 200	1 200	1 200	1 300	1 270	1 400	1 200	-
Incline of up to 8 %	1 500	1 400	1 400	1 400	1 300	1 500	1 400	-
Gross trailer weight (without brakes)	628	637	676	645	670	645	637	-
Trailer nose weight	63	61	63	65	65	70	61	-
Maximum roof bar load	75							





TECHNICAL SPECIFICATIONS

WEIGHTS - DIESEL

Engine type	5-door model						
	HDi 90 BVM	HDi 90 FAP BVM	HDi 110 BVM	HDi 110 FAP BVM	HDi 110 FAP BVMP	HDi 135 FAP BVA	HDi 140 FAP BVM
Fuel tank capacity	Approximately 60 litres						
Recommended fuel	Diesel fuel						
Turning circle between walls (in metres)	11.3	11.3	11.3	11.3	11.3	12	12
French fiscal rating	5	5	6	6	6	7	7
Power (kW)	66	66.2	80	80	80	100	103
Calculated maximum speed in km/h (mph) (in the highest gear)	180	180	192	192	192	206	207
Weights (kg)							
Unladen weight	1 257	1 280	1 270	1 280	1 293	1 416	1 381
Gross vehicle weight (GVW)	1 777	1 800	1 800	1 800	1 800	1 880	1 849
Maximum rear axle weight	850	850	850	850	850	850	850
Gross train weight (GTW)	3 077	3 100	3 100	3 100	3 100	3 350	3 449
Gross trailer weight (with brakes) (within the Gross Train Weight limit)							
10 to 12 % incline	1 300	1 300	1 300	1 300	1 300	1 570	1 500
8 to 10 % incline	1 300	1 300	1 300	1 300	1 300	1 570	1 500
Incline of up to 8 %	1 300	1 300	1 300	1 300	1 300	1 570	1 800
Gross trailer weight (without brakes)	666	677	672	677	675	740	728
Trailer nose weight	66	66	66	66	65	70	73
Maximum roof bar load	75						

XII

154





TECHNICAL SPECIFICATIONS

WEIGHTS - DIESEL

Engine type	3-door model						
	HDi 90 BVM	HDi 90 FAP BVM	HDi 110 BVM	HDi 110 FAP BVM	HDi 110 FAP BVMP	HDi 135 FAP BVA	HDi 140 FAP BVM
Fuel tank capacity	Approximately 60 litres						
Recommended fuel	Diesel fuel						
Turning circle between walls (in metres)	11.3	11.3	11.3	11.3	11.3	12	12
French fiscal rating	5	5	6	6	6	7	7
Power (kW)	66	66.2	80	80	80	100	103
Calculated maximum speed in km/h (mph) (in the highest gear)	180	180	192	192	192	206	207
Weights (kg)							
Unladen weight	1 255	1 279	1 269	1 279	1 293	1 410	1 379
Gross vehicle weight (GVW)	1 775	1 799	1 790	1 799	1 790	1 880	1 835
Maximum rear axle weight	850	850	850	850	850	850	850
Gross train weight (GTW)	3 075	3 099	3 090	3 099	3 090	3 450	3 335
Gross trailer weight (with brakes) (within the Gross Train Weight limit)							
10 to 12 % incline	1 300	1 300	1 300	1 300	1 300	1 570	1 500
8 to 10 % incline	1 300	1 300	1 300	1 300	1 300	1 570	1 500
Incline of up to 8 %	1 300	1 300	1 300	1 300	1 300	1 570	1 800
Gross trailer weight (without brakes)	665	677	672	677	675	740	727
Trailer nose weight	66	66	66	66	65	70	73
Maximum roof bar load	75						





TECHNICAL SPECIFICATIONS

GENERAL: C4 ENTERPRISE*	3-door model		5-door model		
	HDi 90 BVM	HDi 110 BVM	HDi 90 BVM	HDi 90 FAP BVM	HDi 110 BVM
French fiscal rating	6	6	6	-	6
Weights (kg)					
Unladen	1 244	1 276	1 247	-	1 265
Gross Vehicle Weight	1 770	1 800	1 780	-	1 790
Payload (including driver)	526	524	533	-	525
Gross Train Weight	3 070	3 100	3 080	-	3 090
Trailer weight with brakes (within Gross Train Weight)	1 300	1 300	1 300	-	1 300
Trailer weight without brakes	655	675	660	-	670
Trailer nose weight	52	52	52	-	52
Maximum roof bar load	75				

XII

* Applicable to all countries, except France and Overseas France.
For France and DOM-TOM countries, refer to the table on the "Technical Specifications - Weights" page.





TECHNICAL SPECIFICATIONS

FUEL CONSUMPTION

Engine type	1.4i 16V		1.6i 16V		1.6i 16V 120 ch		1.6i 16V 150 ch	1.6i 16V 140 ch	1.6i 16V manual BioFlex
Saloon	BVM	BVM	BVA	BVM	BVA	BVM	BVA	BVM	
Recommended fuel	Unleaded petrol RON 95 - RON 98								E85
Urban	8.7	9.5	10.6	9.3	10.1	9.8	-	9.5	-
CO ₂ emissions	209	224	252	220	240	234	-	224	-
Extra urban	5.2	5.7	5.8	5.2	5.5	5.3	-	5.7	-
CO ₂ emissions	124	135	138	124	131	127	-	135	-
Combined	6.4	7.1	7.6	6.7	7.2	6.9	-	7.1	-
CO ₂ emissions	153	169	180	159	171	164	-	169	-

These consumption values are established in compliance with European directive 80/1268/CEE. They can vary depending on how the vehicle is driven, on the prevailing traffic conditions, on weather conditions, on vehicle load, on how the vehicle has been maintained and also on how many accessories are in use.

The fuel consumption figures quoted are correct at time of going to press.





TECHNICAL SPECIFICATIONS

FUEL CONSUMPTION

Engine type	HDi 90	HDi 90 FAP	HDi 110	HDi 110 FAP		HDi 135 FAP	HDi 140 FAP
Saloon	BVM	BVM	BVM	BVM	BVMP	BVA	BVM
Recommended fuel	5.8	6.0	6.1	6.0	5.8	9.1	-
CO ₂ emissions	154	161	164	161	154	242	-
Extra urban	3.8	4.0	4.0	4.0	3.8	5.1	-
CO ₂ emissions	101	108	108	108	101	136	-
Combined	4.5	4.7	4.8	4.7	4.5	6.6	-
CO ₂ emissions	120	125	128	125	120	175	-

These consumption values are established in compliance with European directive 80/1268/CEE. They can vary depending on how the vehicle is driven, on the prevailing traffic conditions, on weather conditions, on vehicle load, on how the vehicle has been maintained and also on how many accessories are in use.

The fuel consumption figures quoted are correct at time of going to press.





TECHNICAL SPECIFICATIONS

DIESEL FUEL CONSUMPTION with "Michelin Energy Saver" tyres (15 and 16 inch wheels)

Engine type	HDi 90	HDi 110
Saloon	BVM	BVMP
Recommended fuel	-	-
CO ₂ emissions	-	-
Extra urban	-	-
CO ₂ emissions	-	-
Combined	-	-
CO ₂ emissions	-	-

These consumption values are established in compliance with European directive 80/1268/CEE. They can vary depending on how the vehicle is driven, the prevailing traffic conditions, weather conditions, vehicle load, how the vehicle has been maintained and also on how many vehicle systems and accessories are in use.

The fuel consumption figures quoted are correct at time of going to press.





TECHNICAL SPECIFICATIONS

DIMENSIONS (in metres)

	3-door model	5-door model
A	2.608	
B	4.288	4.275
C	0.950	
D	0.730	0.717
E	1.502/1.510	
F	1.497/1.505	
G	1.769	1.773
H	1.456/1.496	
I	1.964	

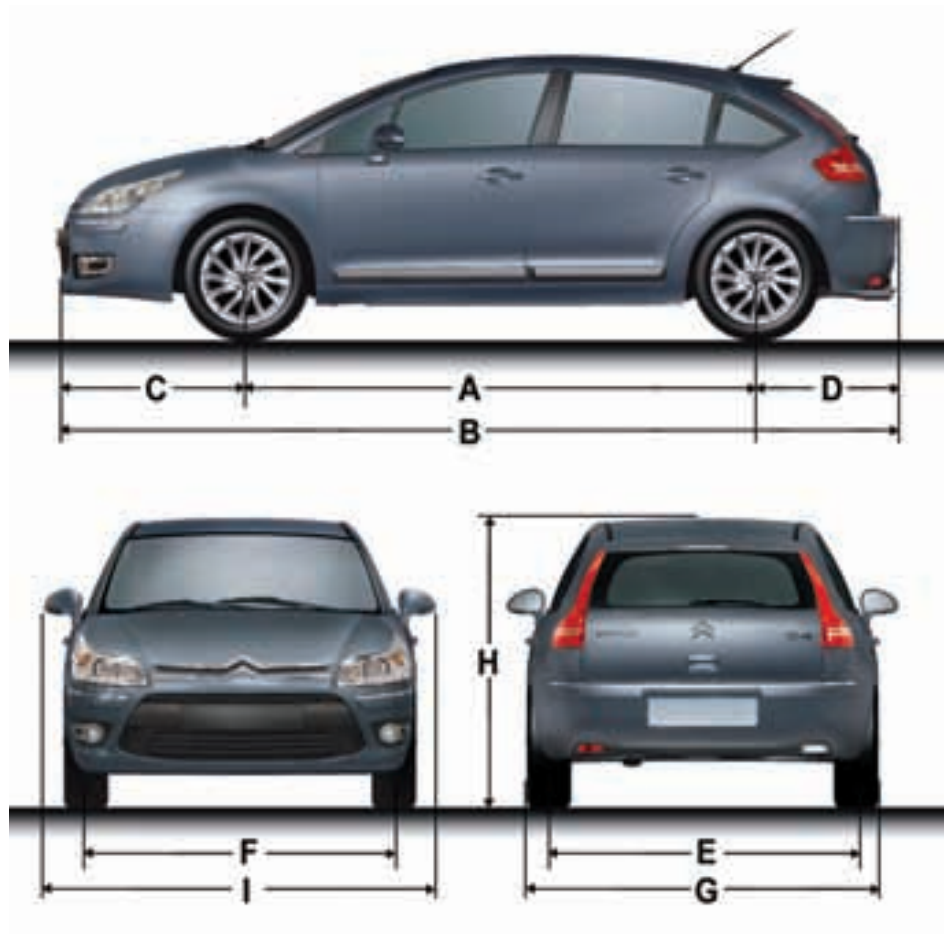



TECHNICAL SPECIFICATIONS

DIMENSIONS (in metres)



3-door model

A	0.903/1.067
B	0.513/0.518
C	0.794
D	1.034
E	0.791
F	1.385
G	0.725
H	0.791



5-door model

A	0.862/1.044
B	0.492/0.515
C	0.794
D	1.034
E	0.791
F	1.385
G	0.725
H	0.791





TECHNICAL SPECIFICATIONS

VEHICLE IDENTIFICATION

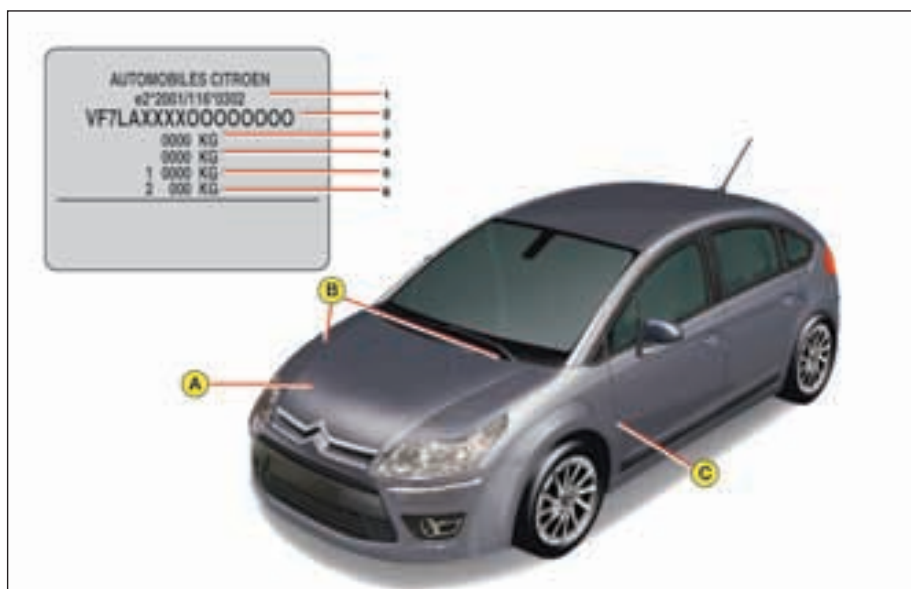

A Chassis number label

- 1: EU type approval number.
- 2: Vehicle Identification N°. (VIN).
- 3: Gross vehicle weight.
- 4: Gross train weight.
- 5: Maximum weight on front axle.
- 6: Maximum weight on rear axle.

B Vehicle identification number

On the bodywork and behind the windscreen.

C Colour code. Tyre reference Tyre pressures

All original CITROËN replacement parts are available from CITROËN. It is in the user's interest, for his safety and for the sake of the warranty, to reject all other parts. Fitting parts or units not supplied by CITROËN may even result in violation of the law, if it involves non-compliance with regulations concerning safety, pollution control, interference suppression and the noise level of the vehicle. Fitting such parts or units could also deprive the user of any recourse against the maker.





AUDIO

RADIO - RDS - CD

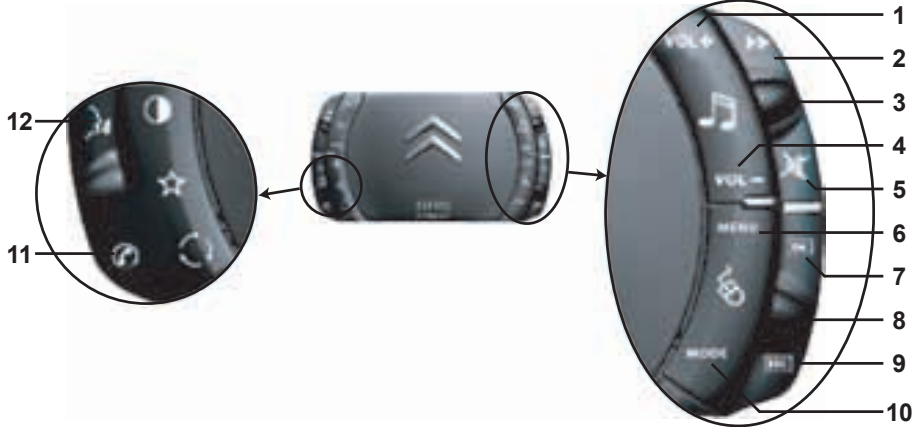
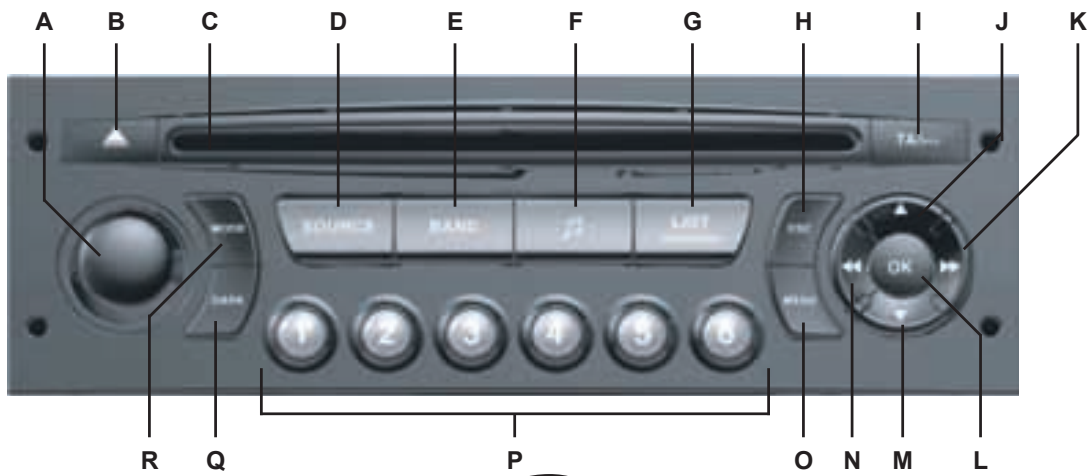



AUDIO

BUTTON CONTROLS

A		On/Off. Volume adjust.	L	OK	Button for validation and activation/deactivation of certain functions. If your vehicle has the Bluetooth® system: Answer call, end call.
B		CD eject.	M		Radio source: Manual search of lower frequencies. CD/MP3 changer source: Selection of the next CD/CD-cover. Other sources: Scrolling in the Main Menu.
C		CD aperture.	N		Radio source: Automatic search of lower frequencies. CD source, CD changer source and MP3 source: Reverse search for tracks. - Long press: Rewind with accelerated sound. Other sources: In the menus, choice of your adjustments. If your vehicle has the Bluetooth® system: Selection of characters.
D	SOURCE	One press: Selection of sound source (Radio, CD, CD changer).	O	MENU	Display of the Main Menu. In certain countries, this control is deactivated while the vehicle is moving.
E	BAND/ AST	Short press: Selection of frequency bands and memory banks. Long press: Automatic pre-set function (Autostore).	P	1-6 1-5	Radio source: - Short press: Recall of pre-set stations. - Long press: Memorisation. CD changer source: Selecting a CD.
F		Call-up of audio adjustments: Sound ambiances, bass, treble, loudness, fade, balance, speed-sensitive volume.	Q	DARK	Short successive presses: - One press: Display of radio, time and temperature only. - Two presses: Display off (blank display). - Three presses: Return to the standard display.
G	LIST	Radio source: - Short press: Display of the list of radio stations available (30 maximum). - Long press: Update of list of stations. CD source: Display of list of tracks of the CD.	R	MODE	Selection of the type of information displayed.
H	ESC	Short press: Cancel the current operation or delete a superimposed display. Long press: Return to the permanent display.	S		CD changer.
I	TA/PTY	Short press: TA function (road information). Long press: PTY function (selection of programme type).			
J		Radio source: Manual search of higher frequencies. CD/MP3 changer source: Selection of the previous CD/CD-cover. Other sources: Scrolling in the Main Menu.			
K		Radio source: Automatic search of higher frequencies. CD source, CD changer source and MP3 source: Forward search for tracks. - Long press: Fast forward with accelerated sound. Other sources: In the menus, choice of your adjustments. If your vehicle has the Bluetooth® system: Selection of characters.			





AUDIO

CONTROLS AT THE STEERING WHEEL

The controls at the steering wheel give you access to certain functions, without you needing to use the radio-CD control panel.

1	VOL +	Volume increase
2		Radio source: Short press: Automatic search of higher frequencies. CD and CD changer source: Short press: Forward search for tracks. Long press: Fast forward with accelerated sound.
3		Radio source: Scrolling of pre-set stations. CD and MP3 source: Search of the track. CD changer source: Selection of next or previous CD.
4	VOL -	Volume decrease.
5		Mute First press: Temporary sound pause. Second press: Restoration of sound.
6	MENU	Access to the main menu to activate/deactivate or choose the adjustments for your vehicle. In certain countries, this control is deactivated while the vehicle is moving.
7	OK	In a menu, a list, an alphabet: Validation of the function, the element or the value chosen. If your vehicle has the Bluetooth® system: Answer call, end call
8		Selection of the next or previous elements of a menu in a screen, a list, an alphabet.
9	ESC	Short press: Cancellation of the current operation. Long press: Return to the permanent display.

10	MODE	Selection of type of information displayed on the right of the screen and, for screen A, choice of activation/deactivation of functions and adjustments.
11		If your vehicle has the Bluetooth® system: Press: Display of the "Directory" menu.
12		If your vehicle has the Bluetooth® system: Press: Activation of voice recognition.

Display A



Display C

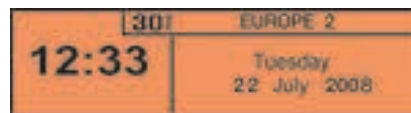

Technical specifications

Your Bluetooth® compatible radio possesses:

- 3 wavebands (MW/LW/FM).
- Dual tuner with RDS EON PTY, display of the PS name, RDS programme search, TA traffic information, 24 pre-selections (18 FM - 6 MW/LW), automatic memorisation of the AST strongest stations.
- An MP3-compatible CD reader.
- Audio power of 4x35 W.





AUDIO

AUDIO SETTINGS

On/Off

With the key in Drive position **M**, press on control **A** to switch the radio on or off.

Note:

- If the radio was on the last time you switched off the ignition, it will resume automatically when you switch on the ignition again. You will not have to press on control **A**.
- After switching off the ignition, you can still operate the audio system even without the ignition key being present. Simply press on button **A**. The system will turn itself off after approx. **30** minutes.

Anti-theft system

This radio is coded in such a way as to function only on your particular vehicle. It would be unusable if installed on any other vehicle.

Note:

The anti-theft system is automatic and requires no action on your part.

Selection of source

To select either Radio, CD (CD already inserted and Radio source activated), or CD changer source, press on control **D**.

When you insert a CD it automatically starts being read.

Note:

When the radio is switched off, the source selected is memorised.

Volume adjustment

Rotate control **A** to increase or decrease the sound volume.

You can also increase or decrease the volume using buttons **1** and **4** at the steering wheel.

Note:

- The sound volume when you switch off the radio will be the same when you switch it on again.
- The radio sound volume automatically adjusts to the vehicle speed, provided the "volume adjustment" function is activated.

Temporary sound pause

Press on control **5** at the steering wheel to activate this function.

The sound will be paused, regardless of the source selected.

To restore the audio output, press one of the controls at the steering wheel.

Sound adjustments

Each press on button **F** brings up the parameter to be adjusted: choice of predefined sound ambiances, bass, treble, loudness, fade (front/rear sound distribution), balance (left/right sound distribution) and volume adjusted to vehicle speed.

Press buttons **K** or **N** to modify the values for the function displayed.

Note:

- The selection of a sound ambiance automatically adjusts bass and treble. These can be modified.

To restore the original adjustments for the musical ambiances, reset bass and treble to zero.

- Adjustment of loudness, as well as bass and treble when they are available, are specific to each sound source and to each musical ambiance.
- If you leave the audio system unactioned for a few seconds, it will revert to the normal display.





AUDIO

RADIO SOURCE

Notes on radio reception

Your radio will be subject to certain phenomena that are not encountered by domestic systems.

The reception of AM and FM signals may suffer from interference, which is caused by the nature and propagation of the signals and does not reflect on the quality of your radio installation.

In AM, the reception may be affected when passing under power lines or bridges, or when travelling through tunnels.

In FM mode, the reception may be affected by the distance from the station transmitter, the reflecting of signals off obstacles (mountains, hills, tower blocks) and radio blackspots (no coverage from the station transmitter).

Selection of radio source

Press button **D** to select the source.

Selection of frequencies and memory banks

Press button **E** successively to go through the memory banks FM1, FM2 and FM3, for the FM waveband, and the memory banks MW/LW, for the AM waveband.

Manual search

Manual search is via buttons **J** or **M**.

By keeping button **J** or **M** pressed, you will be able to scroll through the waveband. Scrolling will stop as soon as you release the button. The radio will remain tuned to the frequency that is displayed.

Tuning sensitivity

Automatic searches can be carried out according to two levels of sensitivity:

- To capture the most powerful transmitters, choose the local search mode "LO" (default option).
- To capture the weakest or most distant transmitters, choose the sensitive search mode "DX".

Search for a station is done first in "LO" (local) sensitivity, then in "DX" (distant) sensitivity.

To commence a search in sensitivity "DX" (distant) immediately, press twice in succession on one of the buttons **K** or **N**.

Automatic search

A short press on one of the buttons **K** or **N** will tune into higher or lower radio stations respectively, within the chosen waveband.

By keeping button **K** or **N** pressed, you will be able to scroll through the waveband. The scrolling will stop at the first station it finds once the button is released.

You can also do this by means of control **2** at the steering wheel.

If the automatic search is unable to tune into a known frequency (perhaps owing to very weak reception), it is possible to search manually to find this station.

Display and selection of a station available in the area in which you are travelling

Briefly press on button **G** to bring up a list of stations, this is updated every **10** minutes.

You can also update this list at any time by giving a long press on button **G**.

To listen to one of these stations, select by pressing buttons **J** or **M** and validate using button **L**.





AUDIO

Manual pre-setting

Select the waveband and memory bank required using button **E**.

Select a station using either automatic or manual search.

Keep pressing for more than two seconds on one of the pre-selection buttons **1** to **6** on the keypad **P**.

The sound momentarily cuts off, then returns to its previous level to confirm that it has memorised the station.

Automatic memorisation of transmitters (Autostore function)

In FM, if you hold down button **E** for more than two seconds, your radio will automatically memorise the 6 strongest stations on the FM3 memory bank.

The display shows "FM AST".

The radio memorises the 6 strongest transmitters, deleting the 6 previously memorised.

After the memorisation, the radio goes directly to memory 1 of memory bank FM3.

Note:

- If the traffic information function has been activated (see RDS SYSTEM), the stations offering this facility will be memorised as priority.

If it is unable to memorise any new stations, the system will retain the previously memorised stations.

- If the system is unable to find 6 stations, the unfilled memory slots will remain free.

Recall of pre-set stations

Press button **E** briefly to select the required waveband and memory bank.

A short press on one of the pre-selection buttons **1** to **6** on the keypad **P** recalls the corresponding memorised station. You can also do this using the control **3** at the steering wheel.

If it is a RDS station, the frequency appears some seconds before the name appears.

For RDS stations, recall of a station may prompt a search for a frequency corresponding to the region where you happen to be (see RDS system).





AUDIO

RDS SYTEM

Using the RDS (radio data system) function on FM

The majority of FM radio stations use the RDS system. The radio in your vehicle has this system.

The RDS system enables these stations to transmit non-audible data in addition to the broadcasting of their programmes. The data provides access to various functions described in this chapter, such as: display of the station name, intermittent traffic information flashes or automatic scanning of stations. This enables you to continue listening to your chosen radio station, regardless of the different frequencies it uses in the regions through which you are travelling.

Scanning of RDS stations

Your radio keeps the best possible reception by continuously looking for any other frequencies on which the selected radio station is broadcast, automatically choosing the frequency offering the best reception (if the station broadcasts on more than one transmitter or frequency).

Activation/deactivation of the RDS functions

The RDS functions can be accessed via the following two menus:

- Main menu (press button **O**).
- AUDIO menu (press button **L**).

To activate/deactivate the RDS functions on the display C:

1. Press button **O**.
2. Select the AUDIO icon using buttons **J** or **M**.
3. Confirm your choice with a press on button **L**.
4. Select the sub-menu for the FM waveband, via buttons **J** or **M**. Confirm your choice with a press on button **L**.
5. Select scanning for RDS stations, via buttons **J** or **M**.
6. Validate your choice with a press on button **L**.
7. Using control **L**, select/deselect to activate/deactivate the function.
8. Validate your choice by selecting **"OK"** on the display.

To activate/deactivate the RDS functions on the display A:

1. Press button **O**.
2. Select the AUDIO-CD icon via buttons **J** or **M**.
3. Select scanning for RDS stations, via buttons **J** or **M**. The system tells you the status (active or inactive) of the function.
4. Modify this status via buttons **K** or **N**.
5. Then please wait for the display to disappear.

Note:

If the RDS function is active:

- The **"RDS"** on the display will light up provided the station being received uses the RDS system with scanning of frequencies.
- The **"RDS"** on the display is barred if the station received uses the RDS system without frequency search.

If your RDS function is deactivated, the **"RDS"** on the display will be absent in all cases.

The display will indicate the **"NAME"** for the stations that use the RDS system and the frequency for stations that do not use it.





AUDIO

Regional search mode

Some stations, when they are organised in networks, broadcast regional programmes at certain times of day, and national programmes at other times.

It is possible to search:

- Either for a regional station only.
- Or across the whole network in order to find a different programme.

To activate/deactivate this function, proceed as for Scanning of RDS stations.

Note:

When this mode is activated, the system will remain tuned to one specific regional station.

TA traffic information (traffic announcements)

Some stations allow broadcasting, only in FM, of these messages thanks to the "TA" function.

You can activate the "TA" function by pressing on button **I**. This allows you, even though you are listening to another audio source or to a radio programme not itself providing traffic messages, to receive traffic information flashes from an FM station which broadcasts them.

While the messages are being broadcast the original source is paused and when the messages have ended your radio will automatically revert to the music programme you were listening to.

Note:

- You have to be in FM wave band.
- The station being listened to should indicate via the RDS system that it broadcasts traffic information.
- Stations organised in a network (EON) have regional transmitters that send their own programmes: while you are listening to one of these stations the system will switch automatically to a station on the network that is broadcasting traffic information.
- You can stop listening to a message by pressing button **I**.

Sound volume adjustment for traffic information

The sound volume for traffic information operates separately from that for the rest of the system, and can be adjusted independently. Rotate button **A** while a traffic information message is being broadcast.

This volume adjustment is memorised.

Selecting a programme type

Certain stations offer the possibility of listening to a particular programme type, selected from a list (PTY).

press for more than two seconds on button **I**.

Press on buttons **J** or **M** to scroll through and select the programme type you prefer, then press on button **L** to validate your choice.

Searching for a station broadcasting this programme type

When you have chosen a programme type, the list of corresponding stations appears on the display, press on buttons **J** or **M** to scroll down and select the station you want, then press on button **L** to validate your choice.

Quitting pty mode

To quit "PTY" mode, select the function to deactivate "PTY" in the list of the different programme types.

Radio text via contextual menu

This function allows you to view the information broadcast by the station, concerning the programme you are currently listening to.

To activate/deactivate this function, proceed as for Scanning of RDS stations.





AUDIO

CD SOURCE

Selecting CD source

After inserting a CD, with the printed side facing upwards, the player will start playing the CD automatically.

To change manually to CD source (CD already inserted), press button **D** until you obtain the source you require.

Ejecting a CD

Press button **B** to eject the CD, the audio system will automatically switch to radio source.

If the CD is not removed within 10 to 15 seconds of being ejected, it will automatically be taken back into the CD player, although it will not be played.

Selecting a track

Press button **K** once to play the next track.

Press button **N** once to return to the beginning of the track currently being played, press a second time to go back to the start of the previous track.

Press the buttons successively to skip several tracks at a time.

This can also be done via the control **G**. As the list of tracks is displayed on the screen, select the desired track using buttons **J** or **M**, then validate using button **L**.

You can also do this by means of control **2** at the steering wheel.

Fast forward and rewind with accelerated sound

To move swiftly through the CD, press and keep pressed button **K** or **N**, respectively for fast forward or rewind with accelerated sound.

Play resumes as normal when the button is released.

Menu

This menu allows activation/deactivation of two options:

- Playback of the first 7 seconds (approx.) of each track of the CD.
- Random playback of the CD tracks.

This can be accessed in two ways:

- Either by pressing button **O** and proceeding as for Search of Stations RDS – for screen C, the sub-menu corresponds to the Audio Preferences.
- Or, provided you are in CD source, by pressing on button **L**. You can then access the Audio menu (for screen C only).

Note:

If one of these options is active, it remains active for CD changer source.

Safety precautions

For safety, do not use a CD player if the cabin temperature is higher than +60 °C or lower than -10° C.

If the temperature becomes too high, an automatic safety device will prevent the CD player from working until an acceptable temperature is restored.

Handling compact discs

Do not drop them. Store the CDs so that they are kept of dust. Avoid touching the disc surface as any scratches may adversely affect the sound quality. Do not attach any stickers to the discs. Do not use damaged or deformed discs. Do not expose them to heat or direct sunlight.

If the surface of the compact disc is dirty, it can be wiped with a soft, clean cloth. Always wipe from the centre of the disc outwards.





AUDIO

MP3 CD player

Your Audio CD system may be MP3 compatible.

As you insert a CD recorded in MP3 format, playback starts of the first song of the first CD-cover.

You can select a particular track by using buttons **N** or **K** and CD-covers using buttons **J** or **M**.

To select a track

To display the list of CD-covers, press on button **G**.

Use buttons **J** or **M** to select the CD-cover you wish to listen to.

To open a CD-cover, press **L**.

Use buttons **N** or **K** to select the track you wish to listen to.

Validate by pressing button **L** or control **7** at the steering wheel.

Menu

This menu is for activation/deactivation of three options:

- Playback of the first 7 seconds (approx.) of each track of the CD.
- Repetition of the current CD-cover.
- Random playback of CD-cover tracks by CD-cover.

This can be accessed in two ways:

- Either by pressing button **O** and proceeding as for Search of Stations RDS – for screen C, the sub-menu corresponds to the Audio Preferences.
- Or, provided you are in CD source, by pressing on button **L**. You can then access the Audio menu (for screen C only).





AUDIO

CD CHANGER SOURCE

CD Changer

This unit (if fitted) is located under the front centre armrest and can receive 6 CDs.

Inserting CDs into the magazine

- To insert a CD, press the LOAD button, then the one for the slot in question. When the indicator lamp for the slot flashes, insert the CD.
- To insert CDs in all of the slots, press the LOAD button for 2 seconds. Insert each CD in turn after its slot indicator lamp flashes.

Note:

- Each compartment takes one disc only.
- The CD changer will not operate if discs are inserted the wrong way up.

Removing discs

- To eject a CD, press the EJECT button then the button for the corresponding slot.
- To eject all the CDs, press the EJECT button for 2 seconds.

Removing discs

To remove a CD, give a long press on the corresponding button.

Play starts with the first track on the first CD.

Selecting a CD

To select a CD, press one of the pre-select buttons **1** to **6** on the keypad **P**, or scroll through them using **J** or **M**.

The CD will start to play automatically.

You can also do this by means of control **3** at the steering wheel.

After each change of source, on return to CD changer source, playback will resume at the same point where it had been interrupted.

Selecting a track

Press button **K** once to play the next track.

Press button **N** once to return to the beginning of the track currently being played, press a second time to go back to the start of the previous track.

Press the buttons successively to skip several tracks at a time.

You can also do this by means of the controls **2** and **3** at the steering wheel.

Fast forward and rewind with accelerated sound

Press and keep pressed one of the buttons **K** or **N** respectively for fast forward or rewind with accelerated sound. Play resumes as normal when the button is released.

Menu

This menu is for activation/deactivation of three options:

- Playback of the first 7 seconds (approx.) of each track of the CD.
- Repetition of the current CD.
- Random playback of tracks, CD by CD.

This can be accessed in two ways:

- Either by pressing button **O** and proceeding as for Search of Stations RDS – for screen C, the sub-menu corresponds to the Audio Preferences.
- Or if you are in CD changer source by pressing button **L**. You then have access to the AUDIO menu (for screen C only).

Note:

If one of these options is active, it remains active for CD source.





AUDIO

HANDS-FREE TELEPHONE

Your audio system may be Bluetooth® compatible. It allows you to connect a mobile telephone for "hands free" use and even to use its directory.

It permits you to twin up to four telephones, to be able then to connect whichever one you choose.

The Bluetooth® functions available and the content of the display are dependent on the type of mobile telephone, its settings and the type of contract you have. For this reason it is advisable to make enquiries with your telephone provider.

Prior to any operation:

- Your display should be lit up (key in position **M**).
- Your telephone's Bluetooth® system must be activated.

Twinning a telephone

Twinning a telephone consists of having it recognised by the Bluetooth® system on your vehicle. This then permits an instantaneous connection.

Twinning can only be performed with ignition switched on, display illuminated, engine stopped. No other telephone should be connected.

- The twinning must be performed with the telephone and its Bluetooth® system activated.

Note:

Refer to the user instructions to familiarise yourself with the features of twinning.

- The telephone detects the Bluetooth® system on your vehicle. "**C4**" displays on your telephone.

You should then select "**C4**" on your telephone controls. Next you must choose whether or not to accept this twinning then select, on screen **C** using **J**, **M** or **8**, one of the **4** memories. Validate with a press on button **L** or **7**.

Note:

You can select a memory already attributed, although the telephone twinned to this location will no longer be.

- Next the telephone asks you to enter an identification code: **1234**.
- Validate.

Note:

This entry may be demanded earlier in the twinning sequence.

The telephone is now twinned to your Bluetooth® system. For immediate access to the Bluetooth® functions, it may be necessary to make a connection (see following page "Configuration: Connecting a twinned mobile telephone").

Once the twinning is finished, you will be able to connect your telephone via the "Main menu".

Connecting a twinned telephone

Each time you enter the vehicle, after switching on the audio system, your telephone is detected automatically. If more than one telephone is present, the last telephone to have been connected is the first to be recognised.

Note:

Disconnections may occur. You may have to make a new connection (see following page, "Configuration: Connecting a twinned mobile telephone").

Remarks:

- In the event of a problem, it is recommended to switch your telephone off and then on again.
- If you switch off your telephone within the field of reception of the Bluetooth® system on your vehicle, the next connection will not be automatic. To restore automatic connection, you will have to connect your telephone manually (see following page, "Configuration: Connecting a twinned mobile telephone").
- If you are already in telephone communication when the audio system is turned on, the latter detects the telephone.
- To avoid interference, you are advised not to place your mobile telephone close to your radio.

To accept an incoming call

Using button **L** or control **7** at the steering wheel.





AUDIO

Main Menu

Press on the Menu control **O** to access the Main Menu, then select the **"Telephone"** icon via buttons **J**, **M** or **8** and then validate the selection via button **L** or **7**.

You have access:

- To the Directory.
- To Configuration.
- To Communication Management.

You access your choices using **J**, **M** or **8** then you validate them with a press on **L** or **7**.

This main menu can also be accessed by pressing button **E** then button **L**.

Directory

This menu lets you open:

- The telephone Directory of the telephone that is connected.
- The Calls List.

This menu can also be accessed with a press on control **11**.

Telephone directory

The starting of a telephone call can be done independently of the telephone or of the audio system, thanks to the directory.

The directory is displayed. Select the number via **J**, **M** or **8**, then validate with a press on **L** or **7**.

Remarks:

- The directory displayed updates itself automatically.
- If the person to be called does not figure in the directory, the call can only be made starting from the telephone.
- If you have information recorded in the Vcard format, you must select the person you wish to call, then validate. A list of 4 numbers maximum can be displayed with the following labels: "Home", "Office", "Mobile" and "Car".

Calls list

After selecting this component and then validating, the calls list is displayed with a maximum of: **10** calls made (arrow pointing upward), **10** calls received (arrow pointing downward) and **10** calls not connected.

It is possible to make a call starting from this list: Select the number via **J**, **M** or **8**, then validate with a press on **L** or **7**.

Configuration

This menu allows you to:

- Deleting a twinning.

Using **J**, **M** or **8**, select this choice then validate via **L** or **7**. Select in the list the telephone that you no longer wish to have twinned. Validate.

- Consulting the list of twinings.

The list of telephones twinned is displayed.

- Connecting a mobile telephone that is twinned.

Select the telephone that you wish to connect. This access allows you to make a connection manually.

Call management

This menu is accessible during your calls, permitting you to:

- Swap a call if there is another call incoming.
- End a call.
- Be in Secret mode.

Remark:

If you are in telephone conversation, you have access to this "Configuration" menu by means of a press on **L** or **7**.





AUDIO

Swapping a call

During a telephone conversation, the system is able to tell you of a second call incoming. To accept it, validate. To change from one call to the other, select this choice.

End a call

This choice enables you to end a telephone conversation, for example if there is another call incoming.

Secret mode

Selecting this choice allows you not to be heard by the other person. To restore sound to the other person, select deactivation of Secret mode in the menu "Call Management".

Note:

If you wish to transfer a call from the audio system to the mobile telephone (for example when leaving your vehicle), refer to the user instructions for the latter.

Voice recognition

A short press on button **12** starts voice recognition for the telephone. Voice recognition allows you to make a call to a number for which you have recorded a label on the mobile telephone that is twinned and connected.

Remark:

It is possible to stop the call as long as the dialling has not commenced, by means of a short press on button **12**.

Remarks:

- While you are on a call, the audio source currently being listened to is paused.
- Some ring tones on your mobile telephone may not be recognised by the Bluetooth® system on your vehicle. A different ring tone will be chosen by the system.

Displays

Press the "**MODE**" button to display telephone information in the right hand part of the display.

A "**Telephone**" symbol appears on your display when you connect a mobile telephone.

A "**Battery**" symbol appears at the bottom of the display to indicate the range of the mobile telephone connected.

An "**Envelope**" symbol appears at the bottom of the display to indicate the presence of an unread SMS on the mobile telephone connected.

A "**Sound track**" symbol appears at the bottom of the display to indicate the presence of a message on the mobile telephone connected.





AUDIO

JBL HI-FI SYSTEM

Your vehicle may be equipped with a JBL Hi-Fi system, specially designed to fit in with your cabin interior.

Adjustment in CD or radio mode

The basic functions remain the same as those for the radio.

No extra adjustment is necessary.

However, to profit fully from your JBL audio system, you are recommended to adjust the audio functions: bass (Bass), treble (Treb), front/rear balance (Fad), left/right balance (Bal) to position **O**, Loudness (Loud) to position **ON** for listening to a CD and position **OFF** for listening to the radio.





AUDIO

FREQUENTLY-ASKED QUESTIONS

The table below provides answers to the questions that are asked the most frequently.

QUESTION	ANSWER	SOLUTION
There is a discrepancy in sound quality between the different audio sources (radio, CD, CD changer etc.).	To achieve an optimum listening quality, the audio adjustments (Volume, Bass, Treble, Ambiance, Loudness) can be adapted to each of the different sound sources, which can produce audible shifts when you change the source (radio, CD, CD changer etc.).	Check that the audio adjustments (Volume, Bass, Treble, Ambiance, Loudness) are adapted to the sources being listened to. It is recommended that you should adjust the AUDIO functions (Bass, Treble, Front-Rear balance, Left-Right balance) to the mid position, select the musical ambiance "None", adjust the loudness correction to the position "Active" in CD mode and to the position "Inactive" in radio mode.
The CD immediately ejects or does not play back.	The CD is the wrong way up, is unplayable, does not contain audio data or contains an audio format that the radio cannot play back. The CD is protected by an anti-pirating protection system unrecognised by the radio.	<ul style="list-style-type: none"> - Check that you have inserted the CD the right way up in the CD player. - Check the condition of the CD: the CD cannot be played back if it is too damaged. - Check the contents if it is a burnt CD: refer to the advice given in the chapter on Audio System. - The radio's CD player cannot play back DVDs. - For reasons of poor quality, some burnt CDs will not be played back by the audio system. - The CD changer does not play back MP3 CDs.
The CD player sound is downgraded.	The CD being used is scratched or of poor quality.	Insert only CDs of good quality and keep them in good condition.
	The radio adjustments (bass, treble, ambiances) are unsuitable.	Return the treble and bass levels to 0, without selecting any ambiance.





AUDIO

QUESTION	ANSWER	SOLUTION
The pre-set stations do not work (no sound, 87.5 Mhz is displayed, etc.).	The waveband selected is not the correct one.	Press on the button BAND AST to retrieve the wave band (AM, FM1, FM2, FMAST) where the stations have been memorised.
Traffic Announcements (TA) is displayed, but I do not receive any road information.	The particular radio station is not in the regional traffic information network.	Change to a radio station which does broadcast traffic information.
The reception quality of the radio station being listened to gradually deteriorates or the pre-set stations do not work (no sound, 87.5 Mhz displayed, etc.).	The vehicle is too distant from the transmitter of the station being listened to, or no transmitter is present in the geographical area you are passing through.	Activate the RDS function to allow the system to check whether a more powerful transmitter is to be found in the geographical area.
	The environment (hills, high buildings, tunnels, underground car parks, etc.) is blocking reception, even in RDS mode.	This phenomenon is normal and does not imply anything wrong with the radio.
	The aerial is absent or has been damaged (for example after going through a car wash or in an underground car park).	Have the aerial checked by a CITROËN dealer.
Cutting of sound for 1 or 2 seconds in radio mode.	The RDS system during this brief sound cut-off is searching for a better frequency that might offer improved reception of the station.	Deactivate the RDS function if the phenomenon occurs too frequently and always on the same journey.
When the engine is not running, the radio stops after a few minutes.	When the engine is switched off, the working time for the radio depends on the vehicle battery charge. The interruption is normal: the radio goes into economy mode, cutting off in order to save the vehicle's battery.	You have to start the engine so as to increase the battery charge.
The message "the audio system is overheating" appears on the screen.	In order to protect the audio equipment in excessive ambient temperatures, the radio goes into an automatic thermic protection mode which results in a reduction in sound volume or stopping of the CD player.	Switch off the audio system for a few minutes in order to allow the system to cool down.





INDEX



- A** A.B.S. 25-85
- Access 57-64
- Accessories
 - socket 12 V.....76
- Adjusting the headlamps.....66
- Adjusting the seat belts 87 ➔ 89
- Adjusting the seats 13-49 ➔ 54-80-82
- Adjusting the steering column56
- Adjusting the time..... 31 ➔ 33-35-37
- Airbags 90 ➔ 93
- Air distribution..... 17-43-46
- Air filter 117 ➔ 119
- Air recirculation..... 10-12-17 -43-46
- Air vents 8-9-41
- Anti-intrusion alarm 60-61
- Ashtray76
- Audio adjustments166
- Automatic dual zone air conditioning 17-45 ➔ 47
- Automatic gear lever..... 100 ➔ 108
- Automatic gearbox..... 106 ➔ 109
- Automatic headlamp lighting65

180

- B** Battery 142 ➔ 144
- Battery
 - replacement..... 142 ➔ 144
- Bluetooth®..... 174 ➔ 176
- Bonnet 116
- Boot 64-77
- Brake fluid 24-119-121
- Brake pads control122
- Braking system..... 85-121
- Bulbs (replacement) 129 ➔ 135
- C** Capacities.....151
- Cargo net.....77
- Cargo rings.....77
- Carrier bag hook.....75
- CD 171-173
- CD changer173
- Central locking..... 57-58
- Changing a wheel..... 125 ➔ 128
- Changing bulbs 129 ➔ 135
- Changing fuses 136 ➔ 141
- Changing remote control battery.....59
- Chassis no.plate.....162
- Child restraints 79 ➔ 82
- Child safety..... 63-78 ➔ 83
- Child seats..... 78 ➔ 82
- Cigar lighter 9-76
- Cold weather screen: "snow-guard"148
- Colour code162
- Coolant fluid 117 ➔ 120

- C** Coolant temperature indicator 23-117 ➔ 120
- Cooling system.....119-120
- Cruise control.....7-10-11-20-110-111
- D** Dashboard 8-9
- Dashboard lighting29
- Date 31 ➔ 37
- Deadlocking..... 57-58
- Defrosting - demisting 17-43-44-47
- Diesel engine..... 118
- Diesel injection equipment..... 122-123
- Diesel preheater25
- Dimensions..... 160-161
- Direction indicators 8-10-24-67
- Directional headlamps.....68
- Distance recorder23
- Driving position52
- E** Economy mode144
- Electric windows..... 15-62
- Electronic gearbox (6-speed) 100 ➔ 104
- Electronic immobiliser key57
- Embellishers 127-149
- Emergency braking assistance.....85
- Engine oil..... 23-29-95-119 -120-151



INDEX

- E** Engine oil level indicator29
- Engines..... 117-118
- Engine levels 117-118
- ESP (Electronic stability programme)..... 8-18-26-86
- ESP deactivation86

- F** Filling the tank124
- Fitting loudspeakers148
- Fixed centred controls steering wheel 10 ➔ 12
- Floor mat73
- Foglamps..... 8-16-66-135
- Folding seat back 53-54
- Folding the rear seats53
- Front seats 49 ➔ 52
- Fuel.....124
- Fuel consumption 157 ➔ 159
- Fuel cut-off switch95
- Fuel flap..... 6-124
- Fuel quality124
- Fuses..... 136 ➔ 141

- G** Glovebox73
- Grab handles.....75
- Guide-me-home lighting65

- H** Handbrake 9-24
- Hazard lamps 9-67-94
- Head restraints 14-50-53
- Headlamp wash.....70-119
- Headlamps 16-24
- Heated seats51
- Hill start assist105
- Horn..... 8-10

- I** Ignition20
- Instrument panels..... 8-23
- Interior lamp 71-132
- Interior lighting..... 71-72
- Isofix (fixings) 81-82

- J** Jack 94-126-127

- K** Keys..... 57-58

- L** Lamps left on.....65
- Lane departure warning system 8-18-96
- Levels and checks 119 ➔ 121
- Lifting, towing145
- Lighting 65 ➔ 67
- Lighting controls 65 ➔ 67
- Loads and towing ... 145 ➔ 147
- Locating of the vehicle59
- Log of alerts..... 12-23
- Loudspeakers114-148

- M** Main beams 24-65-66
- Main menu..... 12-31-32-34-164
- Maintenance 116 ➔ 123
- Maintenance indicator 27-28
- Manual air conditioning 17-43-44
- Manual gearbox.....99
- Mileage counters23
- MP3 172-173
- Multifunction display 9-31 ➔ 40

- N** Navidrive colour screen.....37
- Night driving 29-30

- P** Parking assistance..... 8-101 -114-115
- Particle filter (Diesel)26
- Passenger airbag deactivation 25-92
- Personal security..... 63-64
- Petrol engine 117
- Pretensioners88
- Priming the fuel system.....123

- R** Radiator coolant level 120-121
- Radio...9-32-34-148-163 ➔ 170
- Radio pre-equipment.....148
- Rear demisting 44-47
- Rear seats 53-54
- Rear shelf77
- Rear view mirror..... 55-56
- Rear view mirror (demisting).....55
- Remote control 58-61
- Rev counter 18-23
- Reverse gear21-70-99-101-109
- Roof bars..... 149-150

- S** Safety recommendations 86-87 -94-95
- Scented air freshener48
- Screen wash.....9-119 181



INDEX



S	Seat belt not-fastened	
	detection	25
	Seat belts	19-87 ➔ 89
	Sidelamps	16-24-65-66
	Sill lighting	72
	Spare wheel	125 ➔ 128
	Speed	
	limiter	10-11-20-23-112-113
	Spotlamps	71
	Starter	20-98-102
	Steering lock	9-20
	Steering wheel	
	adjustment	8-56
	Stoplamps	133-134
	Storage	53-74
	Storage drawer	9-73
	Sun visors	75
T	Third stop lamp	134
	Tools	126
	Towbar	147
	Towing	145-146
	Towing ring	126-145
	Trailer weights	151 ➔ 156
	Trip computer	38-40
	Tyre deflation detection	84
	Tyre maintenance	128
	Tyre pressures	84-125-162
	Tyre wear	84 -128
V	Vehicle identification	162
	Ventilation	41 ➔ 47
182	Visibility	65 ➔ 72
	W Warning lamps	24 ➔ 26
	Wash/wipe	16-69-70
	Wear of brake pads	122
	Weights	152 ➔ 156
	Windows	8-15-62-63





INDEX



