

Setting Up Pre-Engineered ClearOne Systems for Optimal Performance

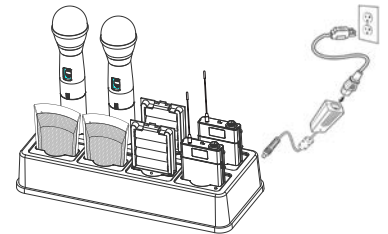

Open the Cartons: Confirm everything on the packing slip is enclosed.

1. **Set up the Docking Station:** ClearOne transmitters are shipped with rechargeable batteries. Plug in the charging dock, put the batteries in the transmitters, then place the transmitters in the dock while you set up the rest of the system.
2. **Mount the Receivers in the Rack** and connect them to power. Confirm the displays light up.
3. **Pre-engineered Antenna Design:** If you provided ClearOne with a floor plan, you will find a marked up version in the box (or, in your Email in-box) showing the antenna design along with the antennas and pre-made cables. Place the antennas according to the drawings.



- A. **Your Own Design:** If you did not request an antenna design, place the antennas according to the enclosed Antenna Applications Guide **Improper antenna placement is the main cause of poor RF performance.**
- B. **Dipole Antennas:** Dipole antennas mounted to the rack equipment can easily be locked away in a closet/rack cabinet. This results in poor RF performance because there is no line of sight between the transmitter and receiver antenna. Therefore, remote antennas are preferred. See the Antenna Application Guide for details.

4. **Connect the Antennas:** The receiver that connects to the antennas should be set as the Antenna Master receiver. Master is the factory default. If your system daisy-chains antennas together, the downstream receivers should be set as Slaves. Terminators are used on the last system in the daisy-chain. Use ClearOne Remote's Antenna Setup Wizard, which opens automatically the first time you connect. You can also find the wizard under the SETTINGS tab of the main page. If connecting ClearOne active remote antennas, make sure the red LED lights up. If not, check the receiver's antenna phantom power setting using the ClearOne Remote Control Software.

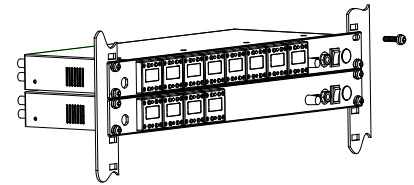

5. **Connect the analog outputs to the mixer:** The system is shipped with Euro block connectors. The default output level is set to +4 dBu. Note that factory default for the front panel headphone jack is set for mixed line-level out. Use ClearOne Remote>Settings>Headphone, to reset for headphones.
CAUTION! Turn off phantom power from the mixer. Phantom power distorts the audio quality of your microphones.

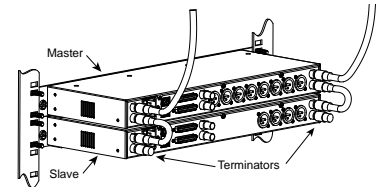

6. **System Test:** In most cases, the system is now ready to use. Confirm all channels pass audio perfectly.

Modifications (FCC 15.21)

Changes or modifications to this equipment not expressly approved by ClearOne may void the user's authority to operate this equipment.

Applies to WS80-T:

Under Industry Canada regulations, this radio transmitter may only operate using an antenna of a type and maximum (or lesser) gain approved for the transmitter by Industry Canada. To reduce potential radio interference to other users, the antenna type and its gain should be so chosen that the equivalent isotropically radiated power (e.i.r.p.) is not more than that necessary for successful communication.

This radio transmitter (WS80-T) has been approved by Industry Canada to operate with the antenna types listed below with the maximum permissible gain and required antenna impedance for each antenna type indicated. Antenna types not included in this list, having a gain greater than the maximum gain indicated for that type, are strictly prohibited for use with this device.

Monopole antenna, 0dbi gain, 50 ohm impedance.

Le présent émetteur radio (DS80-T) a été approuvé par Industrie Canada pour fonctionner avec les types d'antenne énumérés ci-dessous et ayant un gain admissible maximal et l'impédance requise pour chaque type d'antenne. Les types d'antenne non inclus dans cette liste, ou dont le gain est supérieur au gain maximal indiqué, sont strictement interdits pour l'exploitation de l'émetteur.

This device complies with Industry Canada licence-exempt RSS standard(s). Operation is subject to the following two conditions: (1) this device may not cause interference, and (2) this device must accept any interference, including interference that may cause undesired operation of the device.

CLEARONE LOCATIONS

HEADQUARTERS:

Salt Lake City, UT USA
5225 Wiley Post Way
Suite 500
Salt Lake City, UT 84116

Tel: 801.975.7200
Toll Free: 800.945.7730
Fax: 801.977.0087
e-mail: sales@clearone.com

EMEA
Tel: 44 (0) 1189.036.053
e-mail: global@clearone.com

APAC
Tel: 852.3590.4526
e-mail: global@clearone.com

LATAM
Tel: 801.974.3621
e-mail: global@clearone.com

TechSales
Tel: 800.707.6694
e-mail: techsales@clearone.com

Technical Support
Tel: 800.283.5936
e-mail: tech.support@clearone.com

Using the ClearOne remote software:

Editing Transmitter Parameters:

The easiest and most intuitive way to set the parameters of ClearOne transmitters and receivers is with ClearOne Remote software. Load ClearOne Remote from the disk provided onto a computer running Windows XP or Windows 7 (32 or 64-bit) and connect to the receiver via USB or RS232. Then open ClearOne Remote and select ONLINE.

Open The Channel Edit Window:

- 1) The [Click to Edit] function opens the edit window of the channel you wish to edit.
- 2) Select the functions you want to edit and enter the parameter. (*The various functions are described below.*) Click [OK] to save the changes and close the Channel Edit window.
- 3) You will notice that the [Needs to Sync] alert is lit. This indicates that one or more parameters are in queue in the receiver ready to be downloaded and implemented with the next transmitter Sync of the channel.

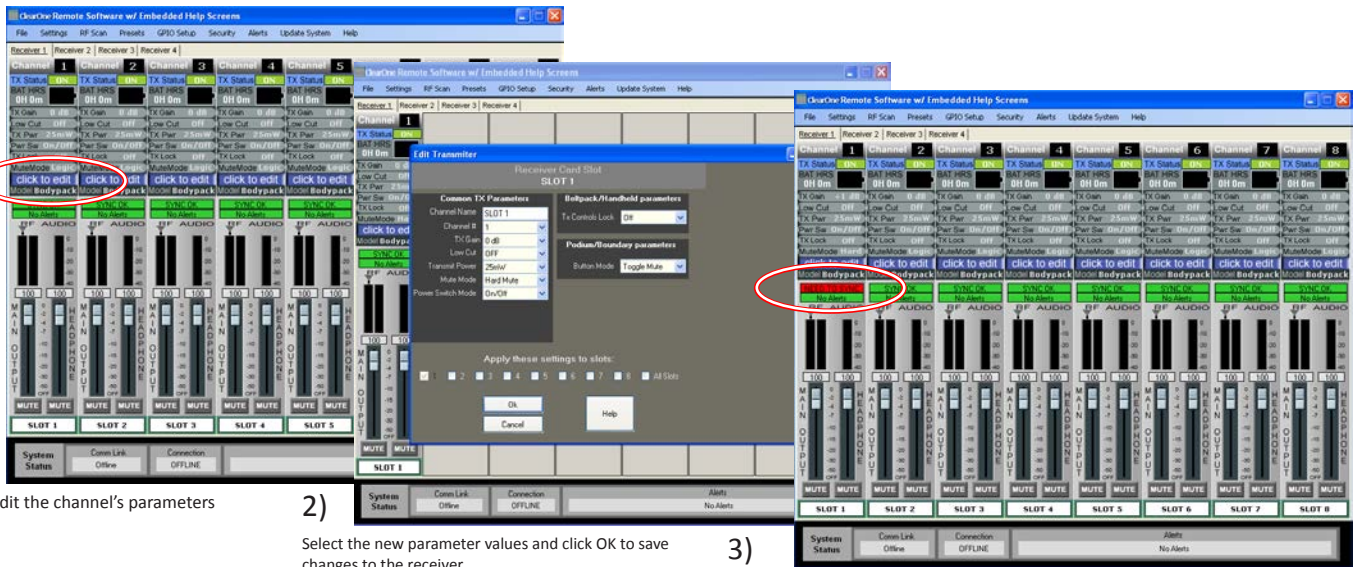

- 1) Click to Edit the channel's parameters
- 2) Select the new parameter values and click OK to save changes to the receiver.
- 3) The "Need To Sync" alert is lit. Sync the transmitter to apply the selected parameters.

ClearOne Remote provides the following functions:

1. **File:** Save a PDF image of the screen.
2. **Settings:**
 - A. **Phantom Power:** Turn antenna phantom power on or off. Default = ON.
 - B. **Redundancy:** Set adjacent pairs of receivers to redundancy mode. Default = OFF.
 - C. **Headphone Mode:** Toggles the mixed output jack from headphone mode to a balanced line output. Default = Balanced line output.
3. **Ethernet Settings:** If using Ethernet, assign the proper IP address to the ClearOne Receiver.
4. **RF Scan - RF Plot:** Shows the RF strength of each antenna in a ClearOne system and shows if there is outside interference.
5. **Presets:** Save or load preset system parameters configurations. Default = As Ordered.
6. **GPIO:** Assign contact closure functions and setup for RS232 control. Default = RS232 - Output mutes.
7. **Security:** Password to prevent unauthorized changes: (Under construction). Default = none.
8. **Alerts:** Send alerts to authorized personal when preventive maintenance is required of if there is a fault. Default = none.
9. **Update System:** Checks to see if the system has the most current firmware and provides a wizard for updating the firmware.
10. **Help:**
 - A. **Tutorials:** Setting parameters, Antenna Application Guide, etc.
 - B. **About:** Shows vital statistics for each component of the system

Default Transmitter Preamp Gain Settings:

Transmitter + Last 4 digits of serial Number	Default Transmitter Preamp Gain
BLT XXXX	+10 dB
HH XXXX	H18 = 0dB, H13 & H18 = +20dB
PDM XXXX	+10dB
BDM XXXX	+20dB

Key:

BLT = Beltpack
HH = Handheld Mic
PDM = Podium Mic
BDM = Boundary Mic

How to sync transmitters with the receiver:

1) Locate the IR (infrared) Sensor on the transmitter

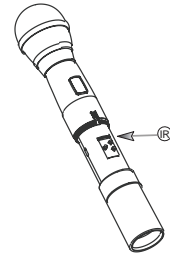
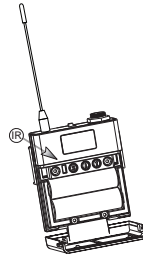
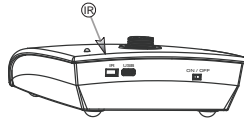
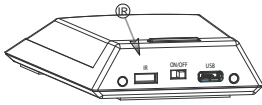

2) Power on the transmitter.

3) Hold transmitter about 6 inches from the corresponding receiver module with the IR sensor aimed at the receiver module.

4) Simultaneously press the two buttons on the bottom of the corresponding receiver module to start sending the IR signal. "SYNCING" shows on the receiver OLED when the IR signal starts. "SYNC OK" shows when the sync is successful. Repeat the procedure if the receiver display shows "SYNC FAILED". It is not necessary to press any buttons on the transmitter during the procedure. Note: You may get a "Sync Failed" message if the receiver antennas are not in the same room as the receiver. In this case verify that either the transmitter display shows "Sync Good" OR the green LED on the transmitter flashes. Also make sure to dock each transmitter after syncing to avoid 2 transmitters being synced to the same receiver frequency.

IMPORTANT: Turn off all transmitters, except the one that is being synced, to avoid two transmitters being synced to the same receiver frequency.

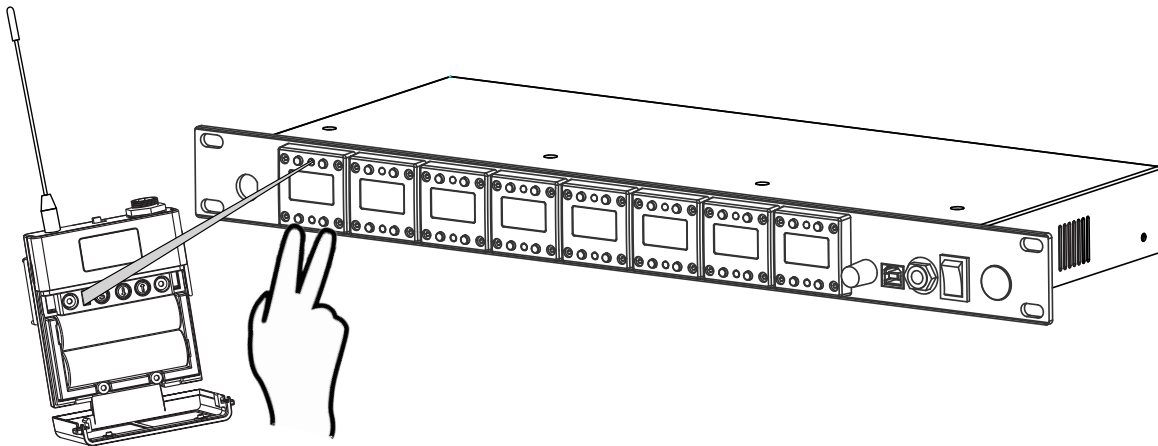

NOTE: The transmitter and receiver are assigned a new, random AES 256-bit encryption key every time they are synced.

How to read the LED:

1. The gooseneck or boundary mic is in use:

- RED = AUDIO MUTE
- GREEN = AUDIO PASSES
- BLINKING RED SLOW = BATTERY IS LOW
- BLINKING RED FAST = BATTERY IS BAD
- BLINKING GREEN = SYNC SUCCESSFUL

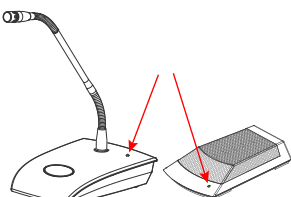

2. The gooseneck battery cassette is in the docking station:

- RED = CHARGING
- OFF/OR GREEN = FINISHED CHARGING
- BLINKING RED = CHARGING ERROR
(RE-SEAT TRANSMITTER AND CHECK THE BATTERIES)

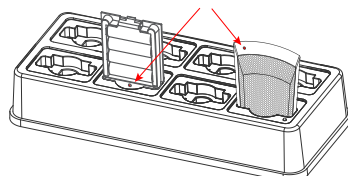

3. The boundary mic is in the docking station:

- RED change to AMBER = CHARGING
- GREEN = FINISHED CHARGING
- GREEN & RED BLINKING = CHARGING ERROR
(RE-SEAT TRANSMITTER AND CHECK THE BATTERIES)

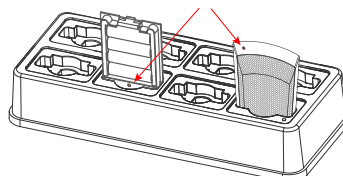

4. Hand-held mic or belt-pack is in the docking station:

The OLED shows the battery status

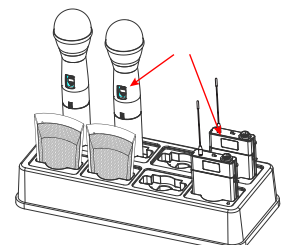

NOTE: All transmitters placed in the charging dock will "RF MUTE".

Receiver:

FRONT PANNEL:

ClearOne receiver main-frames hold either four or eight, independent, 24-bit digital audio receiver modules. There is a front-panel mixed audio output for headphones or direct recording. Each module shares the main-frame's two antennas for full-diversity. Up to eight receiver main-frames can be daisy-chained together into an antenna network that shares two antennas. This eliminates the need for external antenna distribution amps. Main-frames can be connected to form an Ethernet network that monitor and control the system via a computer. Main-frames also have USB and RS233 connections for serial monitor and control. AES/EBU digital audio output and word clock sync is optional.

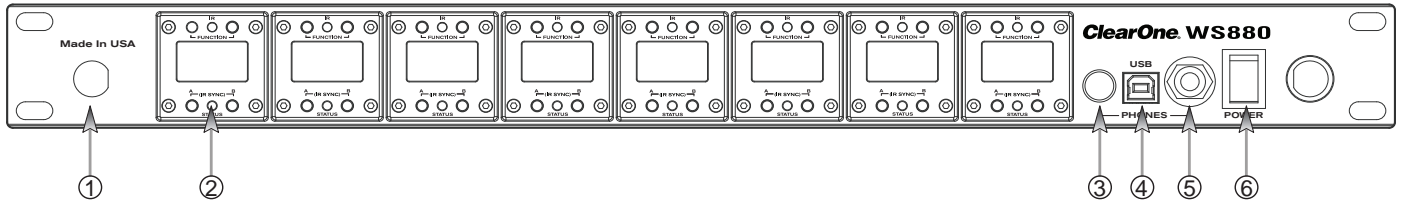

1. Antenna Front Mounting Hole: Use back-to-front TNC cables included.
2. Receiver Module. See details below
3. Mixed audio volume control.
4. USB Port. Connect to computer for ClearOne Remote control. Run software to monitor/edit system parameters, scan for RF interference and download firmware upgrades.
5. Mixed audio output, 1/4" (See *headphone mode - Pg. 2*) phone jack for monitoring individual channels or mixed channels.
6. Power Switch.

RECEIVER MODULE:

MODULE:

Modules are designed for quick and easy field replacement for added redundancy.

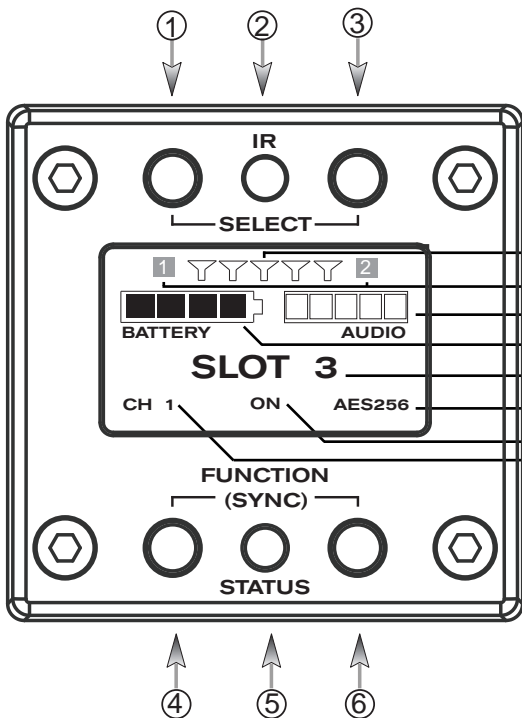

1. **Select Next Function:** Move the cursor to the next menu function on the display (Under construction)
2. **IR Sync LED:** Sends IR information to SYNC the receiver and transmitter (SYNC pg3)
3. **Select Previous Function:** Move the cursor to the previous menu function (Under construction)
4. **Soft Key Left:** Select the choice displayed in the bottom left of the display
- 4 & 6 **pressed at the same time:** Sends SYNC signal from receiver to transmitter (SYNC pg3)
5. **Status LED:**
 - Green --> The channel is ON and un-muted
 - Red --> The channel is OFF
 - Flashing Red --> Encryption key mismatch, Re-sync receiver with transmitter
 - Amber --> The receiver is muted or GPIO is triggered
6. **Soft Key Right:** Select the choice displayed in the bottom right of the display

- RF BARS
- ANTENNA DIVERSITY
- AUDIO LEVEL
- BATTERY LEVEL
- CHANNEL NAME
- ENCRYPTION
- STATUS: (Colored text indicates status)
 - ON = Green
 - OFF = Red
 - MUTE = Amber
 - KEY = Flashing Red ("KEY" = mismatched encryption key)
- FREQUENCY

Receiver:

BACK PANEL WS880:

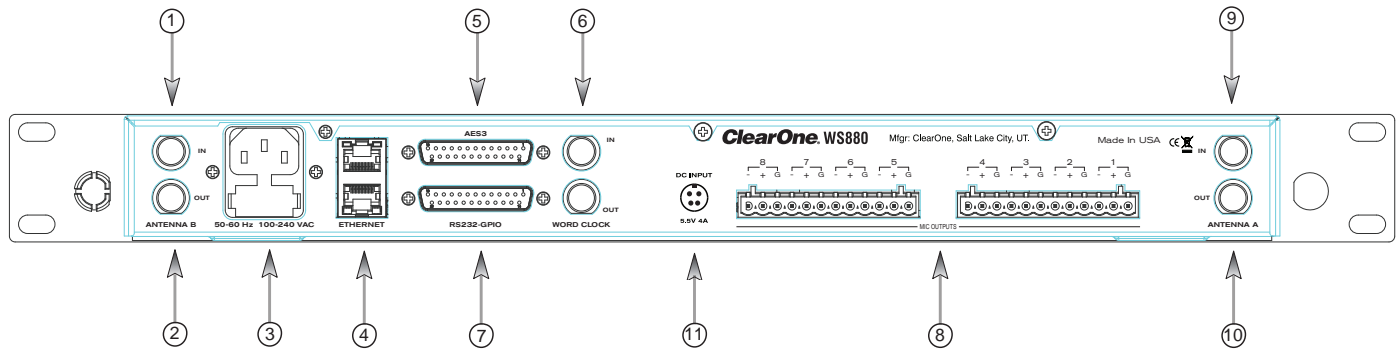

BACK PANEL WS840:

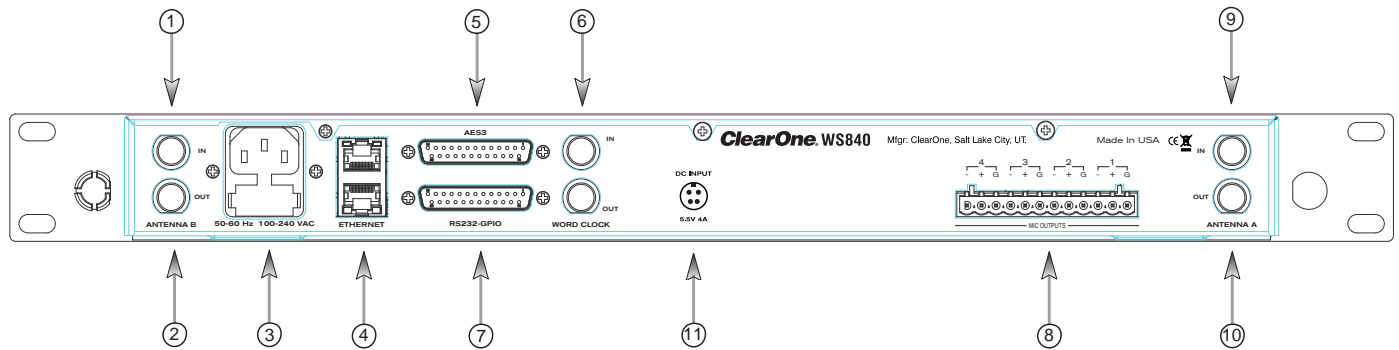

1. **Antenna A Input:** TNC connector for dipole antennas (included), front-to-back antenna cables (included), or antenna cable to active extension antenna.
2. **Antenna A Output:** Daisy-chain to the input of another receiver-frame to form an antenna network.
3. **Power Cord Input:** (Cord with local plug configuration Included). 100-240 VAC, 50/60Hz, 15 W, 250V 320mA slow-blow fuse (spare included)
4. **Ethernet:** Connect to a computer or network. Multiple receiver-frames can be daisy-chained together to form a network. (Under construction)
5. **AES/EBU-3 Digital-Audio Output:** Uses the standard Yamaha wiring convention(1). (NOTE: This feature is optional. The connector jack is included on all receivers, but the feature must be specified at the time of purchase. It cannot be added at a later date.)
6. **BNC connectors:** for word clock digital-audio synchronizing.
7. **GPIO/RS232:** This connector combines a General Purpose Input / Output (GPIO) and a RS232 on one DB25 connector. The RS232 can be disabled to add up to 24 GPIO pins.
RS232: The pinout for the RS232 is the standard pinout. Pin 2 on the receiver is transmit, pin 3 is receive, and pin 7 is ground. Most computers now use a DB9 connector for RS232. The standard off-the-shelf DB9 to DB25 cable will work. This cable swaps pins 2 and 3 internally. If you computer has a DB25 connector for RS232, use a straight DB25 to DB25 cable. Do not use a null modem cable.
GPIO: GPIO acts like a contact closure. Use ClearOne Remote to assign an event that toggles the GPIO pin. The factory default toggles pins X through X to correspond to muting a receiver module. ClearOne Remote has a feature that lets you assign how the system responds to a transmitter mute (see ClearOne Remote)
 A. Mute the channel's receiver audio. (Factory default)
 B. Toggle the GPIO but do not mute the receiver audio. Use this with automated mixers or echo cancelling DSPs.
 C. Mute the channels receiver audio and toggle the GIPO pin.
8. **Audio Output Jacks:** Configured for four or eight-module receiver frames and for XLR or Euro-block terminal connectors.
9. **Antenna B Input:** TNC connector for dipole antennas (included), front-to-back antenna cables (included), or antenna cable to active extension antenna (see section on antennas, antenna placement and antenna cables).
10. **Antenna B Output:** Daisy-chain to the input of another receiver-frame to form an antenna network.
11. **DC Input:** Optional external DC power source eliminates the need for AC input or, can be used as a redundant, back-up power source.

Transmitters:

HAND-HELD:

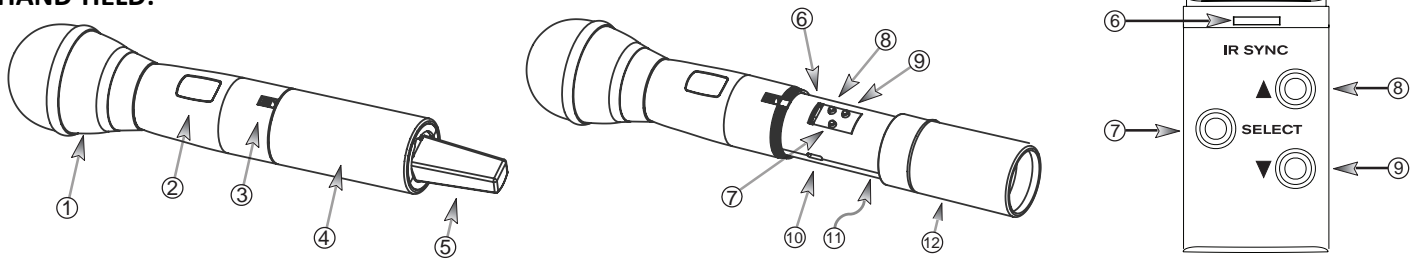

1. **Heads:** Four (4) microphone elements are available, both condenser and dynamic, depending on the application of the microphone user (including Audix OM3 and OM5 dynamic heads). In general, condenser heads are more “transparent” and do not require the microphone to be held as close to the mouth. On the other hand, dynamic heads are often preferred for live performance because they tend to accent the bass tones and they do not distort with very loud singing.
2. **Display:** OLED display is used to program and display the current status of the transmitter functions.
3. **Switch:** User programmable to toggle on/off, on/mute/ or on/on.
4. **Battery and Control Cover:** Unscrew counter-clockwise and gently slide open.
5. **Antenna Cover:** Do not hold the antenna cover. Your hand will shield the RF signal and cause poor audio performance.
6. **IR Sensor Port:** The IR sensor is used to transfer channel settings and a random encryption key from the receiver to the transmitter.
7. **Select button:** Press this button to select a function. The first press activates the first edit able function in the tree. Press again to move to the next edit able function.
8. **Parameter Up:** Press this button to increase the value of the selected function.
9. **Parameter Down:** Press this button to decrease the value for the selected function.
10. **USB Port:** Plug a micro USB cable into the USB port to charge the batteries or upgrade the firmware.
11. **Batteries:** (not shown) AA NiMH, 2200 to 2500-mAhr recommended.
12. **Battery Door:** Open position.

BELT PACK:

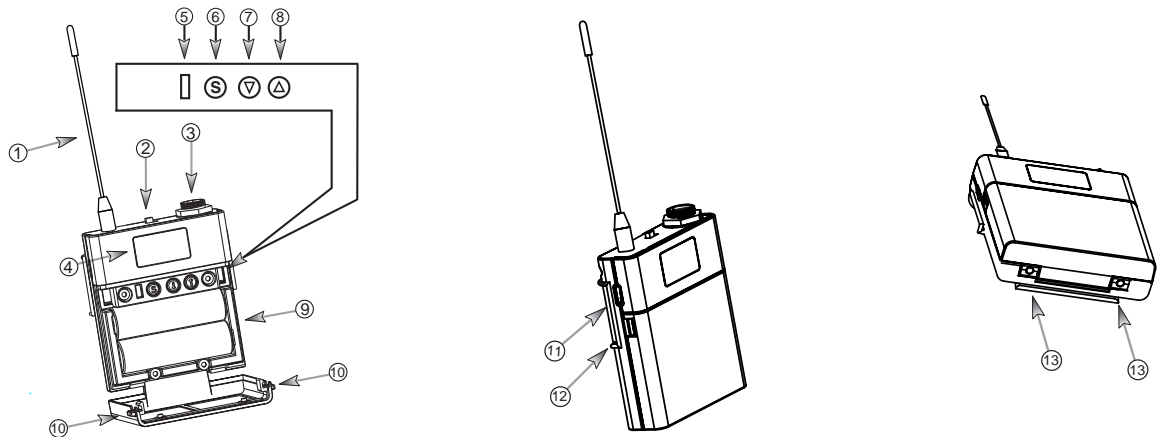

1. **Antenna:** Length and style varies with the transmitters model number. Antennas are field replaceable to improve reliability and redundancy.
2. **Programmable Switch:** Toggle on/off, on/mute/ or on/on.
3. **Microphone Connector:** TA4 mini XLR style: **ClearOne** offers a full range of lavalier and headset microphones for optimal performance of your **ClearOne** transmitter. Works with both snap in and screw-in microphones.
4. **Display:** OLED display is used to program and display the current status of the transmitter functions.
5. **IR Sensor Port:** The IR sensor is used to transfer channel settings and a random encryption key from the receiver to the transmitter.
6. **Select:** Press this button to select a function. The first press activates the first edit able function in the tree. Press again to move to the next edit able function.
7. **Parameter Down:** Press this button to decrease the value for the selected function.
8. **Parameter Up:** Press this button to increase the value of the selected function.
9. **Batteries:** AA NiMH, 2200 to 2500-mAhr recommended.
10. **Battery Door Locks:** To open, press both at the same time and lift the door open. To close, snap the door closed.
11. **USB Port:** Plug a micro USB cable into the USB port to charge the batteries or upgrade the firmware.
12. **Belt-Clip:** Spring-loaded clip for attaching the transmitter to a belt or similar object. Spring pressure presses the clip into two holes in the transmitter body. Pull them out to remove or reverse the clip. Exercise caution to prevent injury or scratching the case.
13. **Contacts:** Charging contact points for the docking station.

Transmitters:

CONFERENCE TABLE-TOP:

The ClearOne Conference Table-top Mic combines the professional audio specs and security of a wired mic with wireless convenience. Available in omni or cardioid polar pick-up patterns with 265-bit FIPS 197 encryption.

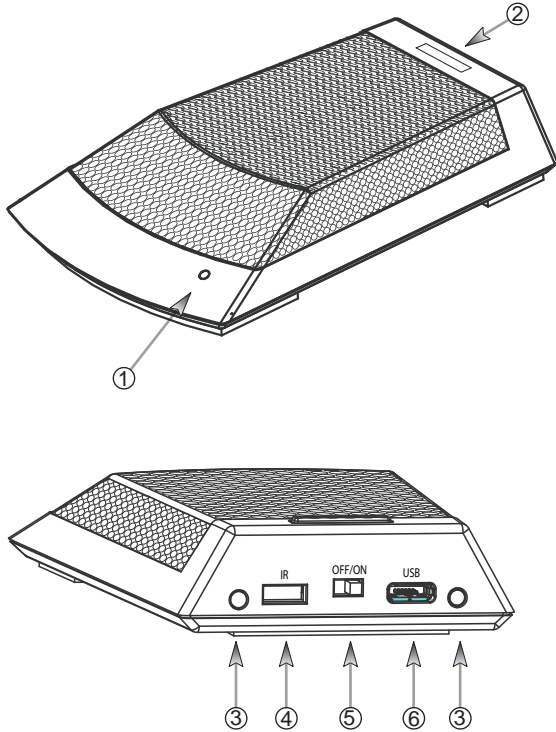

1. **Power LED:** When the Table Mic is on, the LED signals:
 - Red Audio Mute
 - Green..... Audio Passes
 - Blinking Green..... Sync is Successful
 - Blinking Red Slow.. Battery is Low
 - Blinking Red Fast... Battery is Bad
2. **Programmable switch:** Talk, Mute, On/Off
3. **Contacts:** Contact points for the charging station.
4. **I/R Sensor:** Inputs programming instructions and encryption key from the receiver.
5. **Power Switch:** On / Off.
6. **USB Port:** Doubles as the power supply / recharger connection and computer programming port. The transmitter operates normally under USB power, with dead or no batteries for permanent installations.

PODIUM GOOSENECK STEM :

ClearOne Gooseneck Podium Mic Stems are available in 12" and 18" lengths that are interchangeable and feature interchangeable capsules available in cardioid and super cardioid polar patterns.

1. Interchangeable microphone capsule.
2. Flexible stem section.
3. A 4-pin XLR connector allows the exchange of different length microphone stems (12 and 18 inch lengths).

GOOSENECK MIC CAPSULE:

Capsules are interchangeable and are available in cardioid and super cardioid polar patterns.

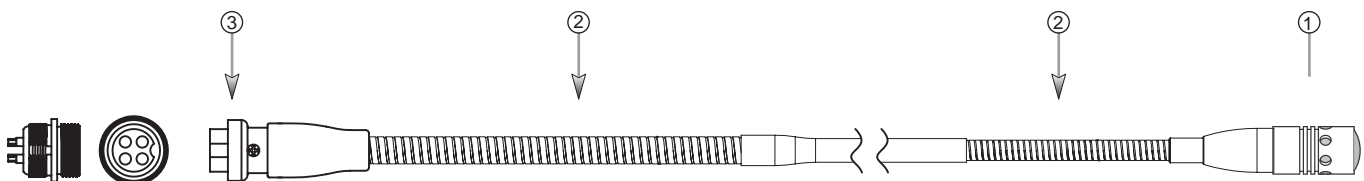
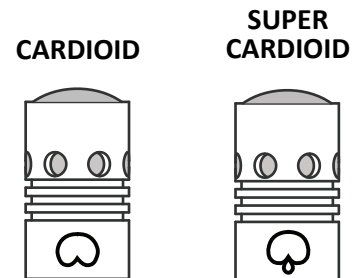

Transmitters:

PODIUM GOOSENECK:

The ClearOne Podium microphone combines the professional audio specs and security of a wired mic with wireless convenience. For use with battery power or permanently install the microphone using USB power.

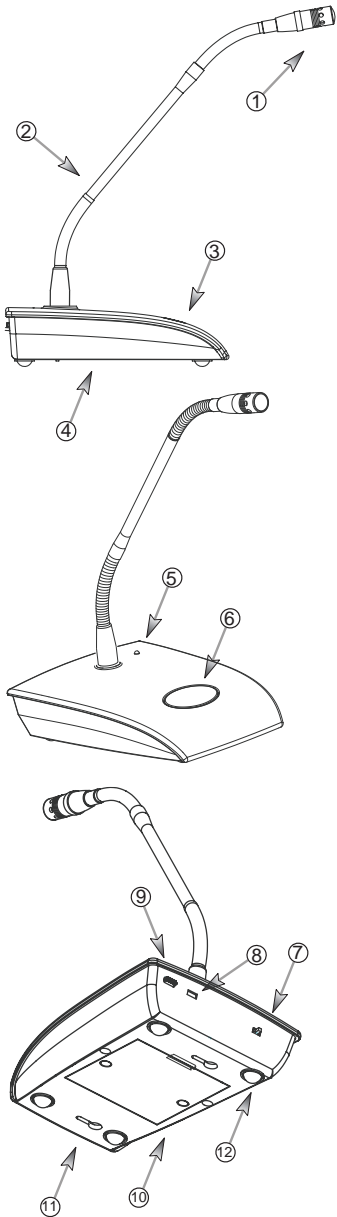

1. **ClearOne Capsules:** Select cardioid or super-cardioid sensitivity polar patterns.
2. **Goosenecks:** Two flexible sections to extend over a laptop or briefcase. Available in 12, 18 inch lengths.
3. **Radio-transparent ABS Top:** Stylish design that hides and protects the antenna.
4. **Cast Metal Bottom:** Zinc base bottom adds stability and absorbs desk noise.
5. **Power LED:** (see fig. 2 below)
6. **Button Programming Options:**
 - press to talk
 - press to mute
 - toggle on or off
7. **Power Switch Programming Options:**
 - On / Off
 - On / Mute
 - On / On.
8. **USB Port:** Doubles as the USB recharger connection and computer programming port. The transmitter operates normally under USB power, with dead or no batteries for permanent installations. When charging using the USB Port, The LED signals: RED = Charging / OFF = finished charging.
9. **I/R Sensor:** Inputs programming instructions and encryption key from the receiver.
10. **Battery Cassette:** Push tab to remove the battery cassette. Recharge the batteries by inserting the cassette into the ClearOne Charging Dock. (See figure 1) The battery cassette holds four, off-the-shelf, AA, NiMH batteries for up to 9.5 hours continuous usage per charge.
11. **Keyholes:** For permanent mounting
12. **Rubber Feet:** Absorb desk noise and provide a stable, non-skid base.

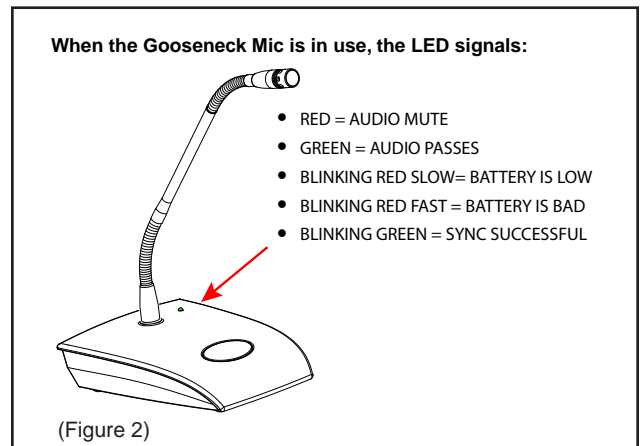
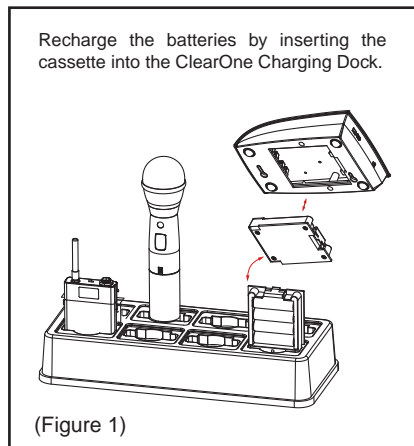

RF Exposure Information for WS800 Digital Wireless Transmitters

- For the WS800 Handheld transmitter: When transmitting, hold the radio in a vertical position with its microphone 2 inches (5 cm) away from your mouth and keep the antenna at least 2 inches (5 cm) away from your head and body
- For the WS800 BodyPack transmitter: To maintain compliance with the Body Worn configuration use only supplied accessories. Other body-worn accessories or configurations may NOT comply with the FCC RF exposure requirements and should be not be used.
- For the WS800 Podium transmitter: Keep the podium base at least 20 cm from your body.
- For the WS800 Conference Table-top transmitter: The antenna(s) used for this transmitter must be installed to provide a separation distance of at least 20 cm from all persons and must not be collocated or operating in conjunction with any other antenna or transmitter, except in accordance with FCC multi-transmitter product procedures. End-users and installers must be provided with antenna installation and transmitter operating conditions for satisfying RF exposure compliance.
- The information listed above provides the user with the information needed to make him or her aware of RF exposure, and what to do to assure that this radio operates with the FCC RF exposure limits of this radio.
- This wireless microphone also complies with the following guidelines and standards regarding RF energy and electromagnetic energy levels as well as evaluation of those levels for human exposure:
 - FCC OET Bulletin 65 Edition 97-01 Supplement C, Evaluating Compliance with FCC Guidelines for Human Exposure to Radio Frequency Electromagnetic Fields.
 - American National Standards Institute (C95.1-1992), IEEE Standard for Safety Levels with Respect to Human Exposure to Radio Frequency Electromagnetic Fields, 3 kHz to 300 GHz.
 - American National Standards Institute (C95.3-1992), IEEE Recommended Practice for the Measurement of Potentially Hazardous Electromagnetic Fields — RF and Microwave.
 - Certified under FCC part 15.247 / Certified by IC in Canada under RSS-210
 - FCC: RBODS80P, RBODS80T, RBODS80H, RBODS80C / IC: 8240A-DS80P, 8240A-DS80T, 8240A-DS80H, 8240A-DS80C