

Vesta Series

Smart Anytime, Safe Anywhere

***HPGWL & HPGW-G Series
IP/GSM+GPRS Alarm System
IP Installation Guide***

Table of Contents

1.	<i>INTRODUCTION</i>	1
2.	<i>PANEL INFORMATION</i>	2
2.1.	IDENTIFYING THE PARTS:	2
2.2.	THE POWER SUPPLY:	3
2.3.	SYSTEM REQUIREMENTS:	3
3.	<i>GETTING STARTED</i>	4
3.1.	SYSTEM DEPLOYMENT	4
3.2.	HARDWARE INSTALLATION	4
3.3.	SOFTWARE INSTALLATION	5
4.	<i>CONNECTION TO PANEL WEBPAGE</i>	8
5.	<i>DEVICE MANAGEMENT</i>	10
5.1.	LEARNING	10
5.2.	ADD RF DEVICE	17
5.3.	LEARN RULE	18
5.4.	WALK TEST	20
5.5.	PROGRAM SIREN	21
5.6.	EXCLUSION	23
5.7.	Z-WAVE TOOL	24
5.8.	PSS CONTROL	25
5.9.	UPIC CONTROL	26
5.10.	SURVEILLANCE	27
5.11.	GROUP CONTROL	28
6.	<i>PROGRAM THE SYSTEM</i>	29
6.1.	PANEL CONDITION	29
6.2.	PANEL SETTINGS	32
6.3.	PIN CODE	36
7.	<i>NETWORK SETTINGS</i>	37
7.1.	GSM (HPGWL-2/3/5 AND HPGW-G2/3/5 ONLY)	37
7.2.	NETWORK	40
7.3.	UPnP	41
8.	<i>SYSTEM SETTINGS</i>	42
8.1.	ADMINISTRATOR SETTING	42
8.2.	HOME AUTOMATION	43

8.3. SCENE	48
8.4. REPORTING	50
8.5. SMS REPORT (HPGWL-2/3/5 AND HPGW-G2/3/5 ONLY)	52
8.6. VOICE REPORT (HPGWL-3 / HPGW-G1D / HPGW-G3 ONLY)	53
8.7. CODE SETTINGS	55
8.8. SMTP SETTING	57
8.9. MEDIA UPLOAD	59
8.10. POLLING	60
8.11. XMPP	61
8.12. VOIP (HPGW-G1D & HPGW-G3 ONLY)	62
8.13. DATE & TIME	63
8.14. DYNAMIC DNS	64
8.15. TEST IP	65
8.16. FIRMWARE UPGRADE	66
8.17. RF FIRMWARE UPGRADE	67
8.18. FACTORY RESET	68
8.19. BACKUP & RESTORE	70
8.20. SYSTEM LOG	71
9. EVENT & HISTORY	72
9.1. CAPTURED EVENTS	72
9.2. REPORTED EVENTS	73
9.3. EVENT LOG	74
9.4. DEVICE HISTORY	75
10. SMS PROGRAMMING COMMAND	76
11. SMS USER COMMAND	77
12. APPENDIX	78
12.1. CONTACT-ID PROTOCOL & FORMAT	78
12.2. EVENT CODE	79

1. Introduction

This section covers unpacking your IP Security System with HPGW Series IP Panel and Security Sensors. Refer to later chapters for information on setting up and configuring the system over the Web Page in more detail.

The advanced IP Security System with fully integrated TCP/IP technology and Ethernet connectivity is able to take full advantage of new advances in IP Home Security and Home Automation and multi-path signalling.

The HPGW Series include the following models:

HPGWL-1 & HPGW-G1: IP Reporting.

HPGW-G1D: IP Reporting, built-in DECT compatibility, VOIP

HPGWL-2 & HPGW-G2: IP + GSM/GPRS.

HPGWL-3 & HPGW-G3: IP + GSM/GPRS, built-in DECT compatibility, VOIP (**HPGW-G3 only**)

HPGWL-5 & HPGW-G5: IP + GSM/GPRS, built-in Z-wave compatibility

2. Panel Information

2.1. Identifying the parts:

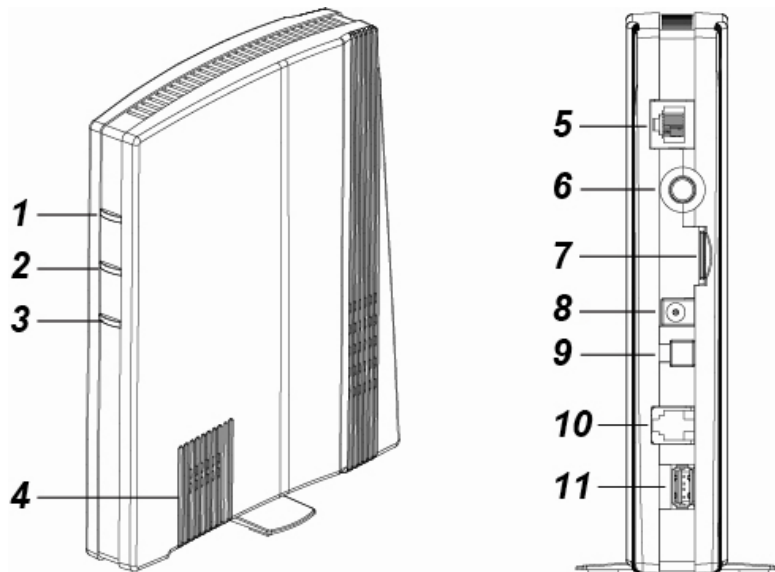
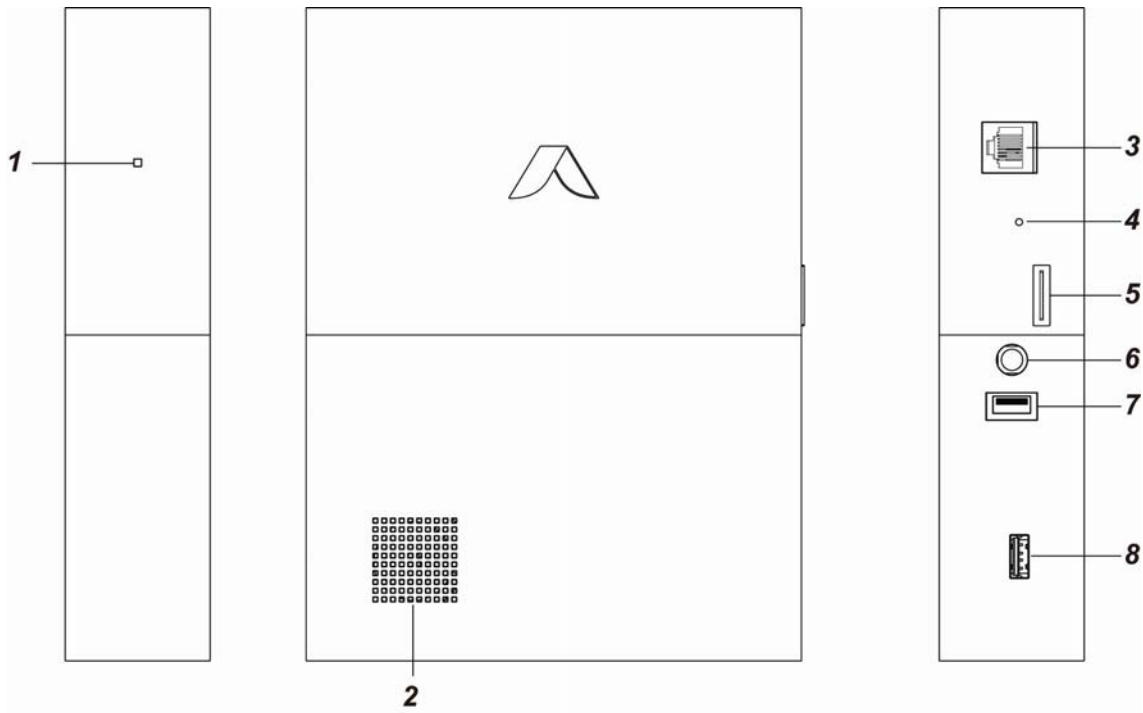

1. System Fault/ Alarm LED (Red/Yellow)

LED 3 Red ON – Alarm in memory

LED 3 Red Flash – Alarm

LED 3 Yellow On – system fault

2. Buzzer

3. Internet Connection

4. Reset/Learn Button

5. GSM Module with SIM card Holder

6. DC Jack

For connecting DC 12V 2A switching power

7. Battery Switch

8. USB Port

- Z-Wave dongle USB port

2.2. The Power Supply:

An AC power adapter is required to connect to a wall outlet. Be sure only to use an adapter with the appropriate AC voltage rating to prevent component damage. DC 12V 2A switching power output adaptor is generally used to power the Control Panel for standard version.

Rechargeable Battery

- In addition to the adapter, there is a rechargeable battery inside the Control Panel, which serves as a back up in case of a power failure.
- During normal operation, the AC power adapter is used to supply power to the Control Panel and at the same time recharge the battery.

<NOTE>

- ☞ Low battery/ restore information will be displayed under the **Panel** section in the web configuration page.
- ☞ It takes 72 hours to fully charge the battery.
- ☞ Only ZigBee and RF modules function normally

2.3. System Requirements:

The system requires a TCP/IP network environment for you to connect to the Control Panel for system programming.

Hardware requirement for programming the panel vial LAN webpage:

- Microsoft Windows 98, ME, NT4.0, 2000, XP, Windows 7 or 8operating system.
- Microsoft Internet Explorer 6.x, or later and Mozilla Firefox 3.0 compatible.
- CD-ROM drive
- CPU: Intel Pentium II 266MHz or above
- Memory: 32MB (64MB recommended)
- VGA resolution: 800x600 or above

3. Getting Started

Read this section of the manual to learn how to set up your Control Panel and program System Settings over the Web page.

3.1. System Deployment

The Control Panel is designed to be wall mounted, follow guidelines below when planning installation location:

- Depend the Control Panel requires Ethernet and/or PSTN connection and may require a SIM card depending on the model.
- The Control Panel should be installed at a location that is hidden from outside view.
- Avoid mounting the Control Panel near large metal objects which may affect wireless radio strength.
- The Control Panel should be protected by sensors so that no intruder can reach the Control Panel without first activating a sensor.
- When using ZigBee routers to improve ZigBee network coverage, remember to use only ZigBee Router with backup batteries for security sensors. If you use a Router without backup battery for security sensors, the Router will be powered down in case of AC failure, and you security sensors will lose connection with the ZigBee network.

Home Automation devices (Power Switches...etc) do not have this limit and can be used with any Router.

3.2. Hardware Installation

- Step 1.** For configuration and operation of Control Panel via Ethernet, connect the IP cable to the RJ-45 connector.
- Step 2.** For HPGWG/L- /2/3/5, insert the SIM card to the SIM card holder. (**Optional**) Before inserting a SIM card, please make sure the pin code is deactivated and SMS messages are removed first.
- Step 3.** Connect the Power Adaptor to a Wall Outlet and the other end to the Control Panel. After several seconds, the Control Panel will emit 2 beeps to indicate that the system is now operational.

<NOTE>

- ☞ Please make sure the GPRS/MMS function of GSM SIM Card is open.
- ☞ If the SIM Card is changed or removed, please power off the panel then power on again.
- ☞ If a GSM fault occurs, please re-insert the SIM card and then reset the GSM in **GSM** setting page.

3.3. Software Installation

※ THIS INSTALLATION IS ONLY REQUIRED FOR FIRST TIME USER ※

1. RUNNING THE FINDER SOFTWARE

The Finder software is required for your computer to identify the control panel on the LAN. To install the “Finder” software”

Step 1. Insert the supplied CD-ROM into your CD-ROM drive

Step 2. Find the **Finder** software in the CD-ROM.

Step 3. Double click on the **Finder_v1.x** to initiate the installation.

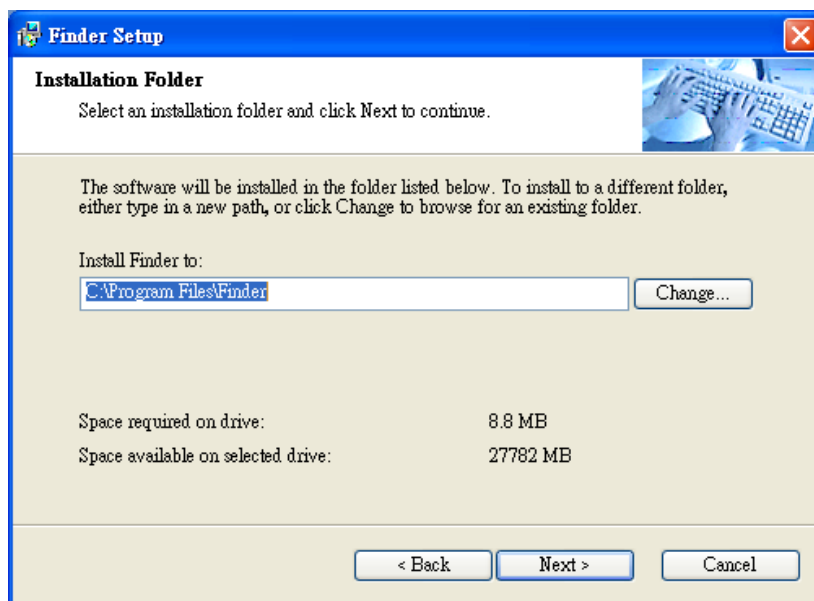

Step 4. Follow on screen instruction to complete installation

Step 5. Once complete, the Finder icon will be displayed on your desktop.



Step 6. Double click on the “**Finder.exe**” to start the software. Finder will automatically search for control panel on the LAN and display its information. If available, the panel’s LAN IP address, Firmware version and MAC address will be displayed

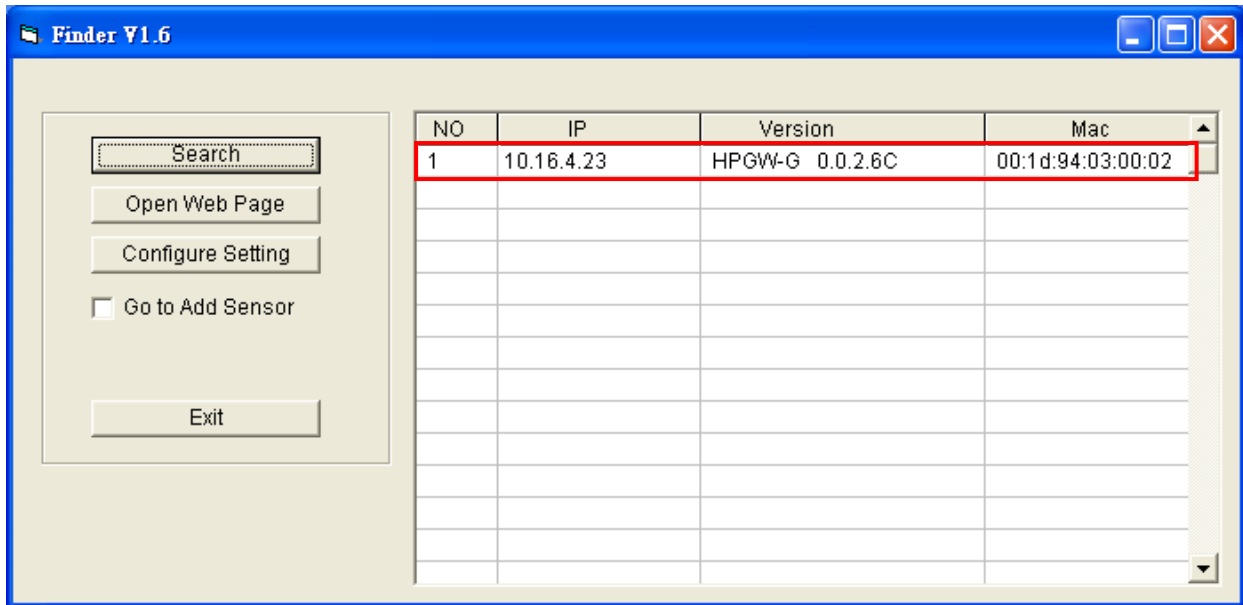

Step 7. If the panel information is not displayed, check panel power and Ethernet connection and click on “**Search**” to update the panel information.

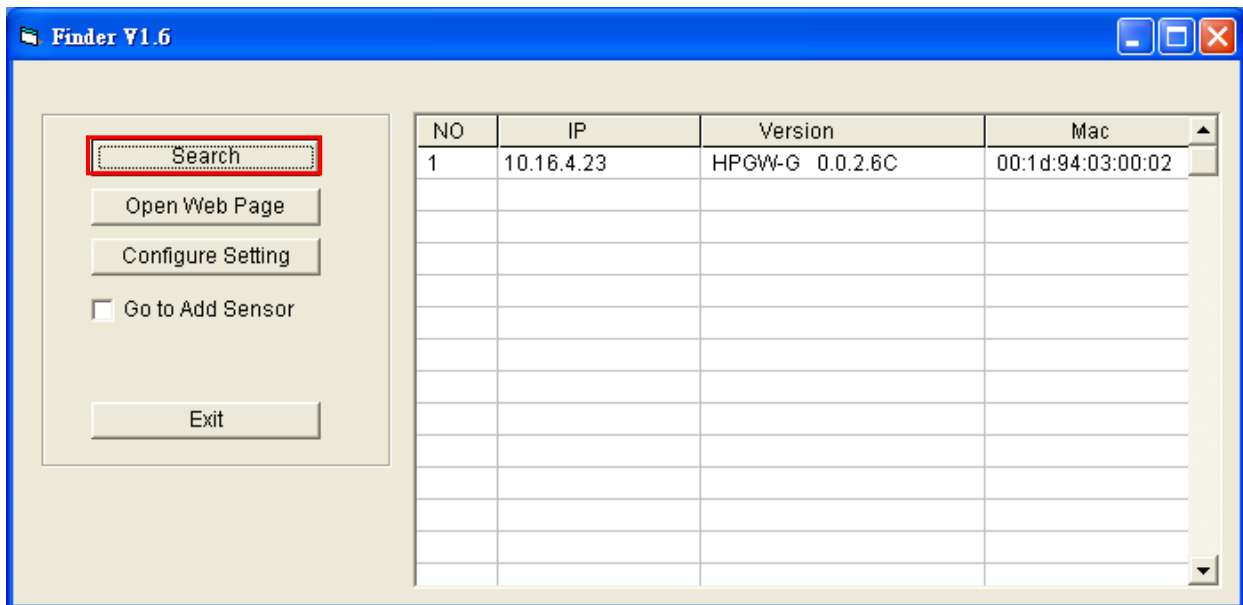

Step 8. (Optional) You can choose to edit the panel's network setting by clicking on the panel column, then click "Configure Setting"

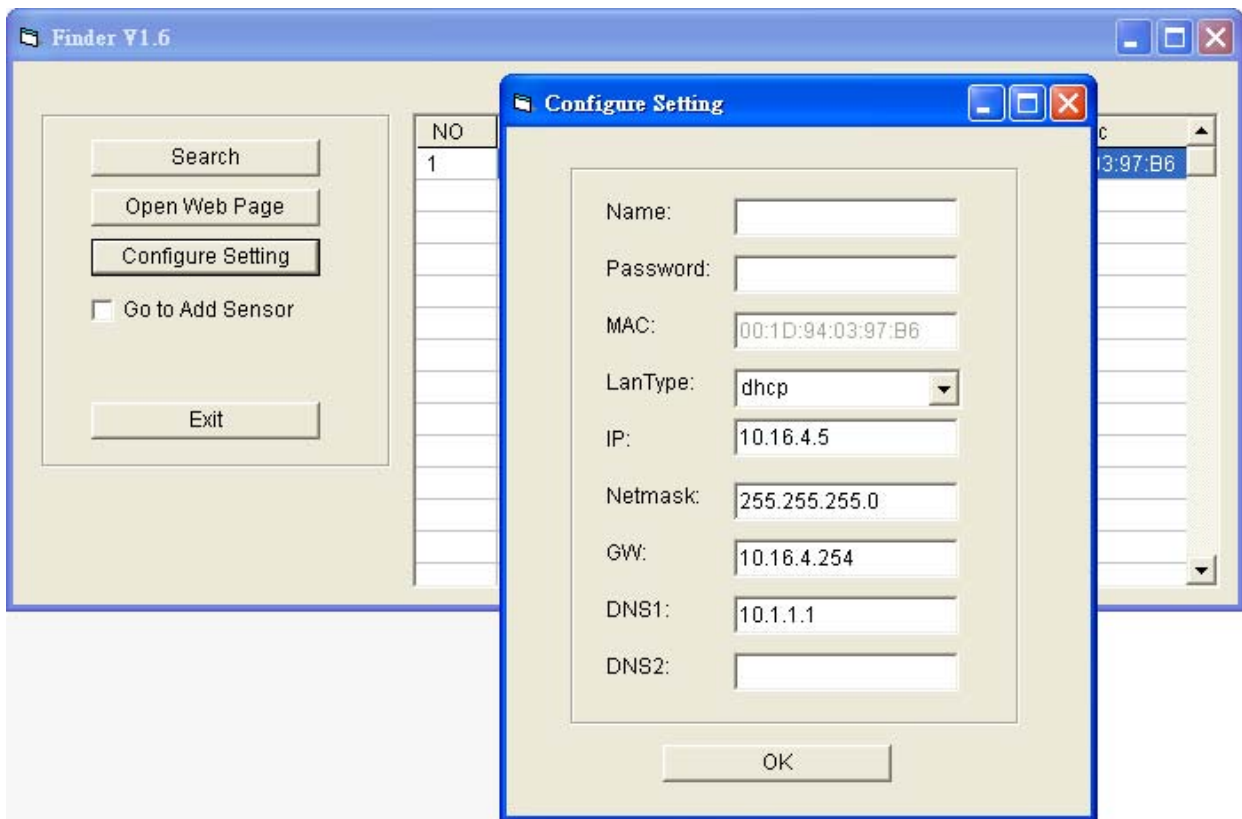

The LanType is default to **DHCP** and does not require manual input of IP/Netmask/Gateawy/DNS setting. If you wish to configure these setting manually, change LanType to **Static**.

After finish changing network setting, enter the user name (default: **admin**) and password (default:**admin1234**) then click **OK** to confirm. The user name and password can be changed later in panel configuration webpage

Step 9. Click the panel information column and click on "**Open Web Page**", or double click on the panel column to link to the panel configuration webpage. Your default browser will start automatically to connect to the LAN IP displayed in Finder.

4. Connection to Panel Webpage

Step 1. With a valid Ethernet connection, open your browser, enter the panel's IP address as shown in the Finder softer under address section and click "GO" to connect to panel webpage. Alternatively, you can also double click on the panel information in Finder software to open the webpage.

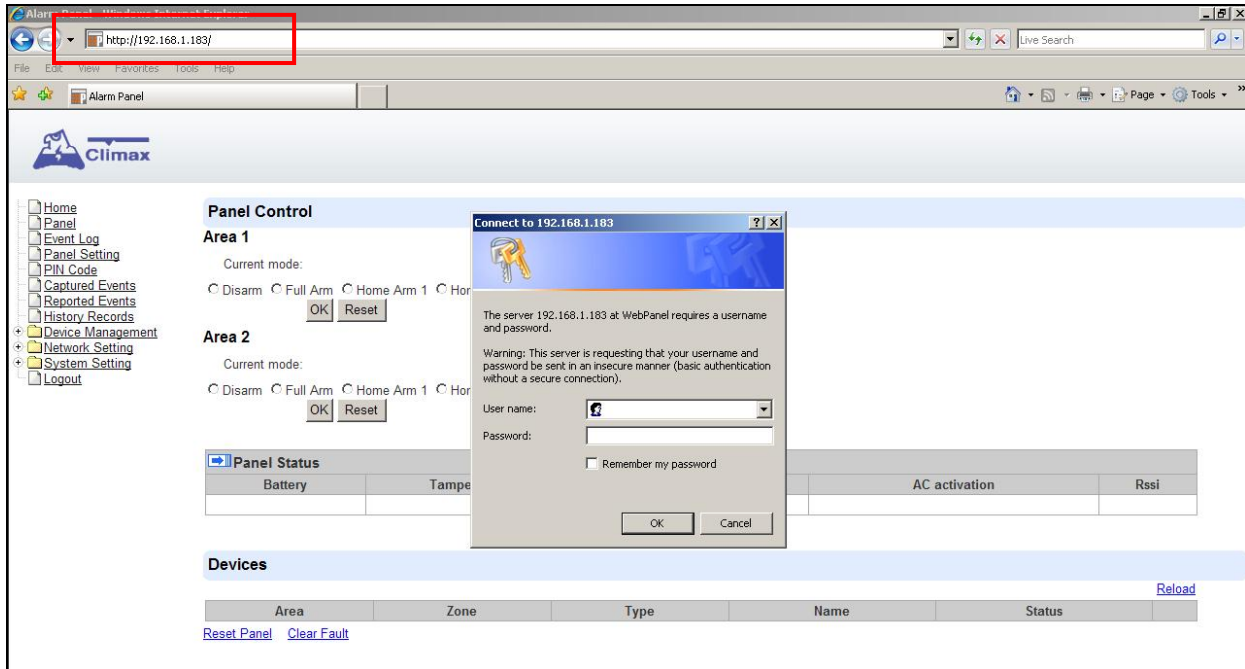

Step 2. You will be required to enter the User name & Password.

Default User name: **admin**

Password: **admin1234.**

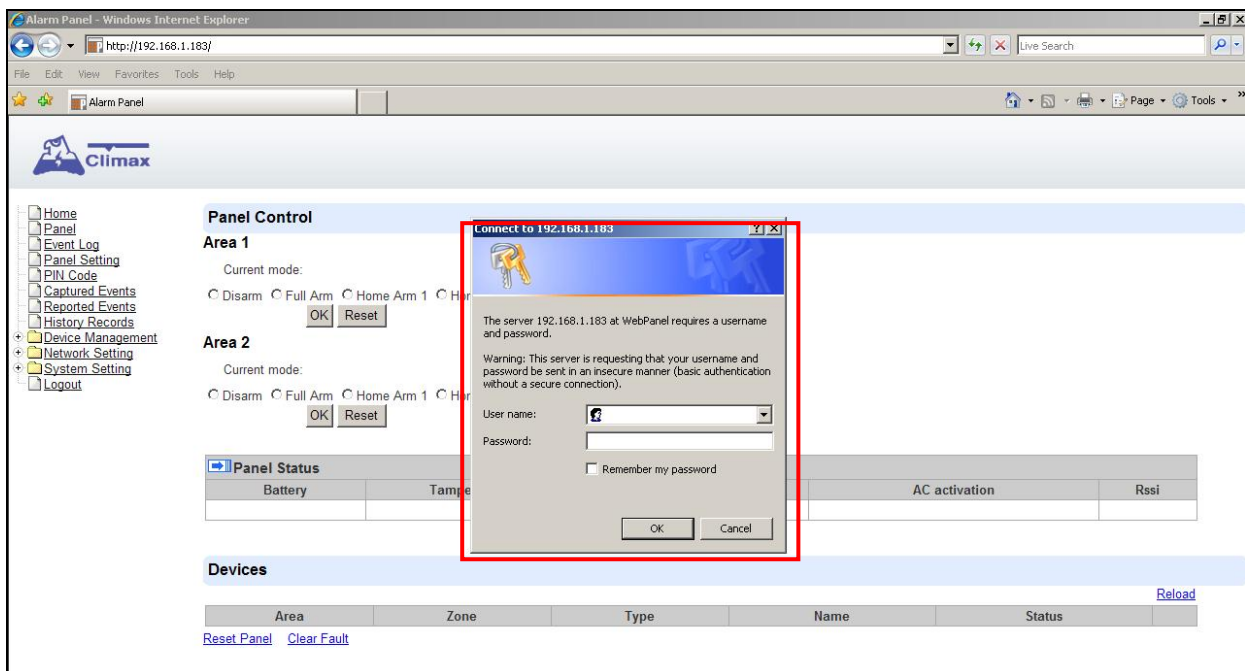

Step 3. You will enter panel Welcome page. The Control Panel's information will be displayed. Click on the pages and folders on the left to access the Control Panel's various functions.



- Home
- Panel
- History Records
- Event Log
- Panel Setting
- PIN Code
- Captured Events
- Reported Events
- Device History
- + Device Management
- + Network Setting
- + System Setting
- Logout

Welcome to Alarm Panel!

Firmware revision: HPGW-G 0.0.2.6C HPGW-L2-XA24 2.0.2.6.1

Firmware/RF revision: HPGW-L2-XA24

ZigBee revision: 2.0.2.6.1

Z-wave revision:

GSM revision: Cinterion BGS2-W REVISION 01.301

Public IP Address: 59.124.230.221

Internal IP Address: 10.16.4.23

MAC Address: 00:1d:94:03:00:02

©2014 Climax Tech. Co., Ltd.

5. Device Management

The Device Management section allows you to learn in, edit, control and view all available accessory devices that can be included in the HPGW Series Control Panel.

5.1. Learning

Use this function to add new devices into the Control Panel. HPGW Series supports up to 160 zones of accessory devices, in 2 areas, up to 80 zones each area.

The following types of accessory devices are supported:

- **RF device:** All Climax RF devices are supported. (For ZigBee only model, RF devices are not supported.)
- **ZigBee device:** All ZigBee device with ZigBee Home Automation 1.2 profile are supported.

<IMPORTANT NOTE>

- ☞ The Control Panel built-in ZigBee module supports up to **40** ZigBee devices by itself. If you wish to include more than 40 ZigBee devices into the Control Panel, you must add extra ZigBee Routers into the Control Panel's ZigBee network to increase the network's maximum device capacity.
- **IP Cameras:** The Control Panel is compatible with Climax VST-1818 Series IP Camera. Up to 6 IP Cameras are supported.
- **DECT Device:** HPGWL-3, HPGW-G1D and HPGW-G3 only only. Up to 4 Climax DECT device are supported.
- **Z-Wave Device:** Available for HPGWL-5 and HPGW-G5, other models requires additional USB Z-Wave Dongle.

5.1.1. Add Sensor

Step 1. Click on “**Learning**” on the tool bar and then the following screen will be displayed.

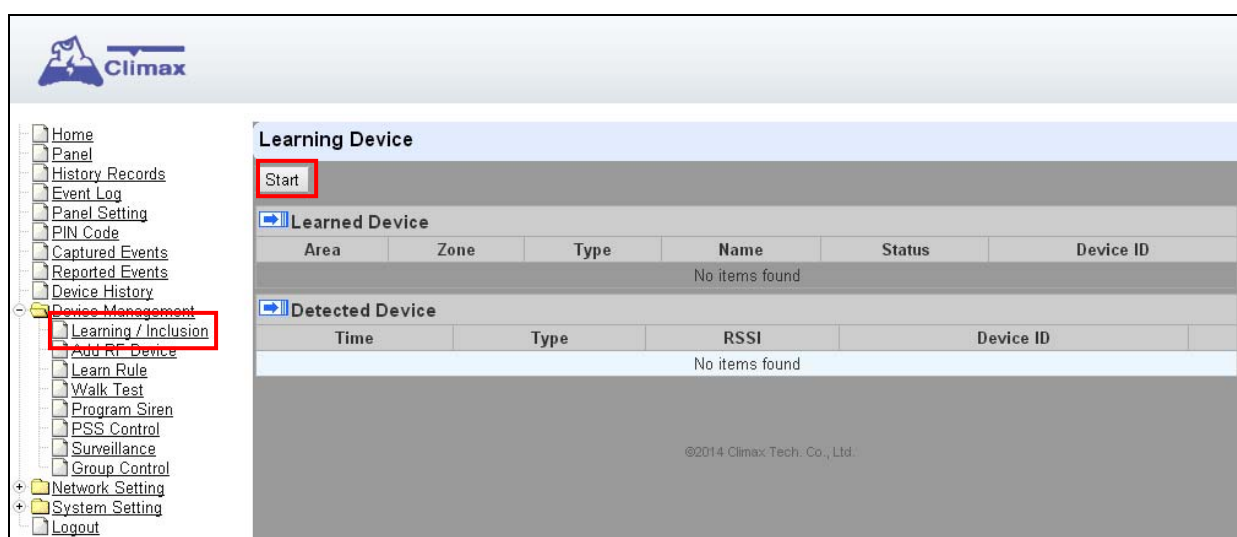

Step 2. Click on “**Start**” to enter learning mode.

Step 3. Press the test or learn button on the each device or any button on the Remote Controller. (Please refer to each sensor's user manual for test or learn button position).

<NOTE>

- ☞ For ZigBee sensors, press and hold the learn button for 10~12 seconds to transmit a learn code.
- ☞ For IP Camera VST-1818 Series, press and hold the Privacy button for 10 seconds.

Step 4. When the system received the signal transmitted from device, the screen will display its information for selection.

<NOTE>

- ☞ It takes 5-10 seconds for the Control Panel to receive a learn code from ZigBee or Z-Wave Sensor.

Step 5. Click “Add” to include selected device into panel. If the sensor you wish to learn into already exists in the system, the sensor information will be displayed in the **Learned Device** section. If not, the sensor information will be displayed in the **Detected Device** section.

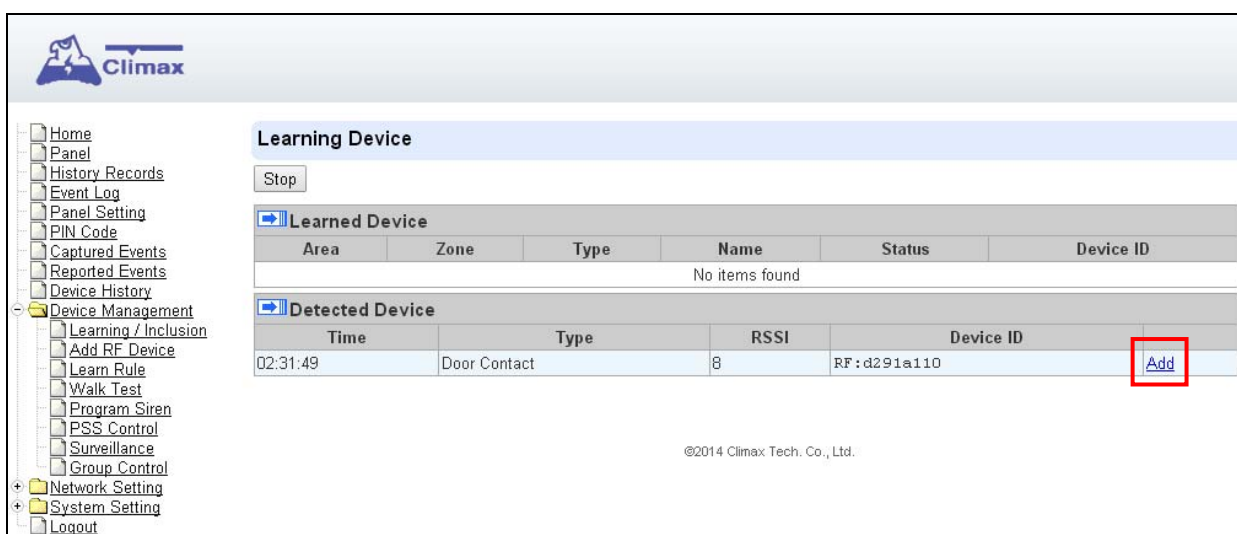

Step 6. If the device is successfully learnt into the system, the added device will be displayed in the “Learned Device” section.

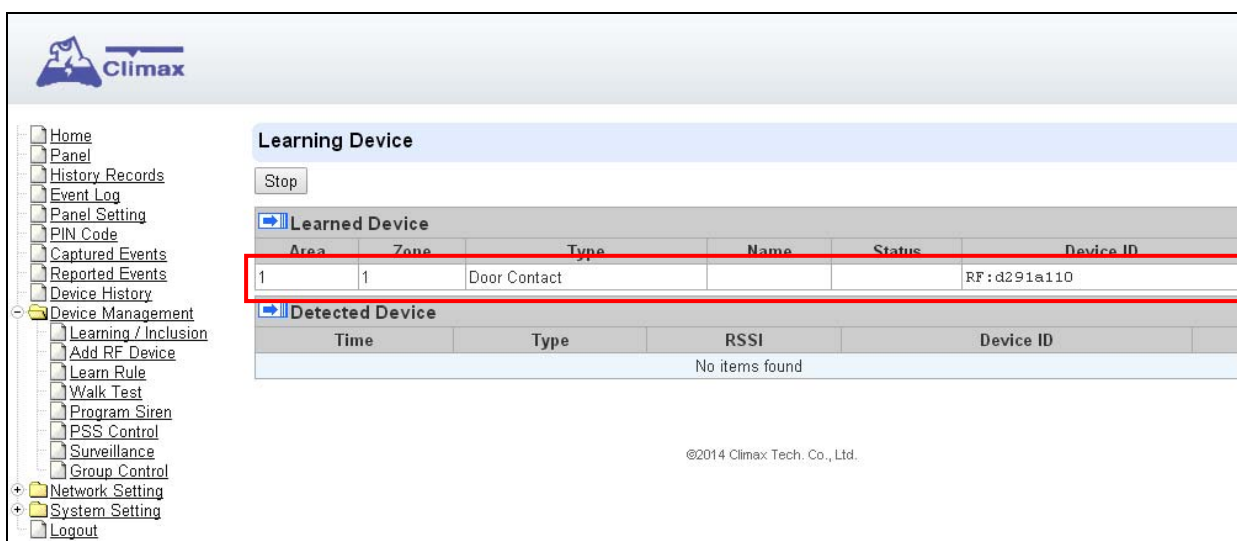

Step 7. Repeat Step 3~5 to learn in all device, click Stop to exit learn mode when complete.

5.1.2. Local Learning

Instead of learning devices via configuration webpage, you can also learn in devices by using the learn button located on the back of Control Panel.

- Step 1.** Press and hold the **Learn** Button on the back of Control Panel for 10 seconds, release when the Control Panel emits one short beep. LED 1 and LED 2 Green will turn ON to indicate the Control Panel is now in learning mode
- Step 2.** Press the test or learn button on each device to transmit signal, refer to device manual for detail.
- Step 3.** When the Control Panel receives signal from device, it will emit 2 beeps to confirm. The device will be included in the panel automatically.
- Step 4.** After finish learning all devices, press and holde the Learn button for 1 second. The Control Panel will emit 2 short beeps to indicate it has returned to normal mode. LED1 and LED 2 will dim.

<NOTE>

- ☞ Device learnt in via Local Learning will be assigned to Area 1 only, which is limited to 80 devices.
- ☞ The Control Panel cannot enter learning mode when under Away Arm/Home Arm or Walk Test mode. The Control Panel will emit 5 beeps to indicate error.

5.1.3. Edit Devices

After finish learning devices, proceed to edit the device setting.

Step 1. Click **Panel** to enter Panel webpage. All learnt in devices will be displayed under **Device List** section.

Panel Control

Area 1
Current mode: Disarm
 Disarm Full Arm Home Arm 1 Home Arm 2 Home Arm 3

Area 2
Current mode: Disarm
 Disarm Full Arm Home Arm 1 Home Arm 2 Home Arm 3

Panel Status

Battery	Tamper	Interference	AC activation	Signal GSM	Background RSSI
Normal	N/A	Normal	Normal	N/A	0

Test System:

System in maintenance

Fault Status

Fault	Setting
SIM Not Inserted	<input type="checkbox"/> Clear
GSM No Signal	<input type="checkbox"/> Clear

Reload

Device List

Area	Zone	Type	Name	Condition	Battery	Tamper	Bypass	RSSI	Status	
1	1	Door Contact		█	█	█	No	N/A		Edit Delete

Note

No.	Type	Description	
#1			Edit
#2			Edit
#3			Edit
#4			Edit
#5			Edit

Step 1. To edit the device setting or information, click “**Edit**” at end of device entry.

Area	Zone	Type	Name	Condition	Battery	Tamper	Bypass	RSSI	Status	
1	1	Door Contact		█	█	█	No	N/A		Edit Delete

Step 2. You will enter Device Edit webpage

Step 3. Edit your device setting and information according to instruction below. Click “OK” to save your new changes when finished. Alternatively, click “Default” to reset all parameters to default values or click “Reset” to re-enter all the information.

- Name: Enter a name for the device.
- Area: Select the area which the device belongs to.
- Zone: Select the Device zone number.
- Bypass: this function allows user to deactivate (bypass) the selected device.
If bypassed, then the Control Panel will not respond at all when the sensor is triggered.
If bypassed, the system can be armed directly regardless the device’s fault situation. However, its fault situation will still be monitored, logged and displayed in the history records webpage.
- Latch Report (Only for Remote Controller or Door Contact with Set/Unset attribute enabled):
Latch Report ON = Whenever the system is armed, home armed or disarmed, the Control Panel will report the arm/disarm event by the particular device
Latch Report OFF = Whenever the system is armed, home armed or disarmed, the Control Panel will NOT report the event.
- Set/Unset: For Door Contact only. This function allows Door Contact to control system mode..

Normal Close = The system will be armed when the Door Contact is opened, and disarmed when Door Contact is closed.

Normal Open = The system will be armed when the Door Contact is closed, and disarmed when Door Contact is open.

- 24H: this function enables the sensor to report an selected alarm event whenever it is triggered regardless of system mode..
- Disarm/ Full/ Home 1/ Home 2/ Home 3 response: if the system is in the disarm / Full/home1//home2/home3 mode, when a sensor is triggered, it will respond according to the attribute you set.
- Trigger Response: When the device is triggered, the Control Panel will activated pre-programmed scene setting. Please refer to **Scene** webpage for detail.
- Exit: if **No Response** is ticked, the sensor does not repond to any trigger when the system under Exit Delay Time 1/2. If **No Response** is not ticked, the sensor will raise burglar alarm and report immediately when triggered during Exit Delay Timer.

- **Attribute List:**

☞ **No Response**

- When a sensor with **No Response** is triggered, the Control Panel will not respond.

☞ **Start Entry Delay 1/ Start Entry Delay 2**

- When the system is under Full Arm or Home Arm mode, if a sensor with **Start Entry Delay 1/2** attribute is triggered, Control Panel will start an entry countdown period to give enough time to disarm the system.
- When the Control Panel is in the Disarm mode, if a sensor with **Start Entry Delay 1/2** attribute is triggered, the Control Panel will immediately report a burglar interior alarm (**CID code: 132**).
- When the Control Panel is in the Full Arm mode, if a sensor with **Start Entry Delay 1/2** attribute is triggered, the Entry Delay 1/2 timer starts counting down. If no correct pin code is entered during the entry delay timer to disarm the system, the Control Panel will report a burglar perimeter alarm (**CID code:131**) immediately after entry delay timer 1/2 expires.
- When the Control Panel is in the Home Arm 1/2/3 mode, if a sensor with **Start Entry Delay 1/2** attribute is triggered, the Entry Delay 1/2 timer starts counting down. If no correct pin code is entered during the entry delay period to disam the system, the Control Panel will report a burglar interior alarm (**CID code: 132**) immediately after entry delay timer 1/2 expires.

☞ **Chime**

- When the system is in Arm/ Home Arm 1/ Home Arm 2/ Home Arm 3 mode, if a sensor set to Chime is triggered, the Control Panel will sound a Door Chime (Ding-Dong Sound).

☞ **Burglar Follow**

- When the system is in Full Arm or Home Arm mode mode, if a sensor set to **Burglar Follow** is triggered, the Control Panel will report a burglar alarm immediately.
- When a Start Entry sensor is triggered and the system is under Entry Delay Timer countdown, if a sensor set to **Burglar Follow** is triggered, the Control Panel will wait until the Entry Delay Timer expires before activating a burglar alarm. If the

system is disarmed before the timer expires, the Control Panel will not activate alarm.

 **Burglar Instant**

- When the system is under Full arm or Home Arm/ Disarm / Entry Time mode, if a sensor set to **Burglar Instant** is triggered, the Control Panel will report a burglar alarm immediately.

 **Burglar Outdoor**



- When the system is in Full Arm or Home Arm / Disarm / / Entry Time mode, if a sensor set to **Burglar Outdoor** is triggered, the Control Panel will report a burglar outdoor event immediately.

 **Apply Scene**

- The attribute is for Trigger Response only. You can select a Home Automation Scene number with this function. When the device is triggered/activated, the Control Panel will execute the actions programming in the Scene accordingly. For more information, please refer to **8.3. Scene**.

5.1.4. Delete Devices

Step 1. To delete a sensor, click “Delete” under “Device List”

Device List										
Area	Zone	Type	Name	Condition	Battery	Tamper	Bypass	RSSI	Status	
1	1	Door Contact					No	N/A		Edit Delete



Step 2. A message “Delete success” is displayed and the sensor you choose is deleted successfully.

5.1.5. Identify ZigBee Device

The Identify function is available for ZigBee device only, it can be used to locate ZigBee devices after learning.

For battery powered ZigBee devices, the identify fuction should be used within 1 minute after pressing device button, or 3 minute after learning in the device. Otherwise due to ZigBee network mechanisms, the device may not be able to receive signal successfullly from panel. AC powered ZigBee devices do not have such limits and you can use Identify function anytime.

Step 1. Click “Identify” under the Device List after the device column entry.

Device List										
Area	Zone	Type	Name	Condition	Battery	Tamper	Bypass	RSSI	Status	
1	1	Repeater					No	N/A		Edit Delete Identify

Step 2. If the ZigBee device receives signal successfully, the webpage will display a success message and the ZigBee device LED indicator will flash 10 times to confirm.

<NOTE>

-  If a timeout message is displayed on webpage, it means the device did not receive signal from Control Panel, please check ZigBee device range from panel and make sure to follow instruction above about Identifying battery powered ZigBee devices.

5.2. Add RF Device

Besides learning, you can also add RF devices into the system by entering its RF code into the system with **Add RF Device** function.

Step 1. Click **Add RF Device**.

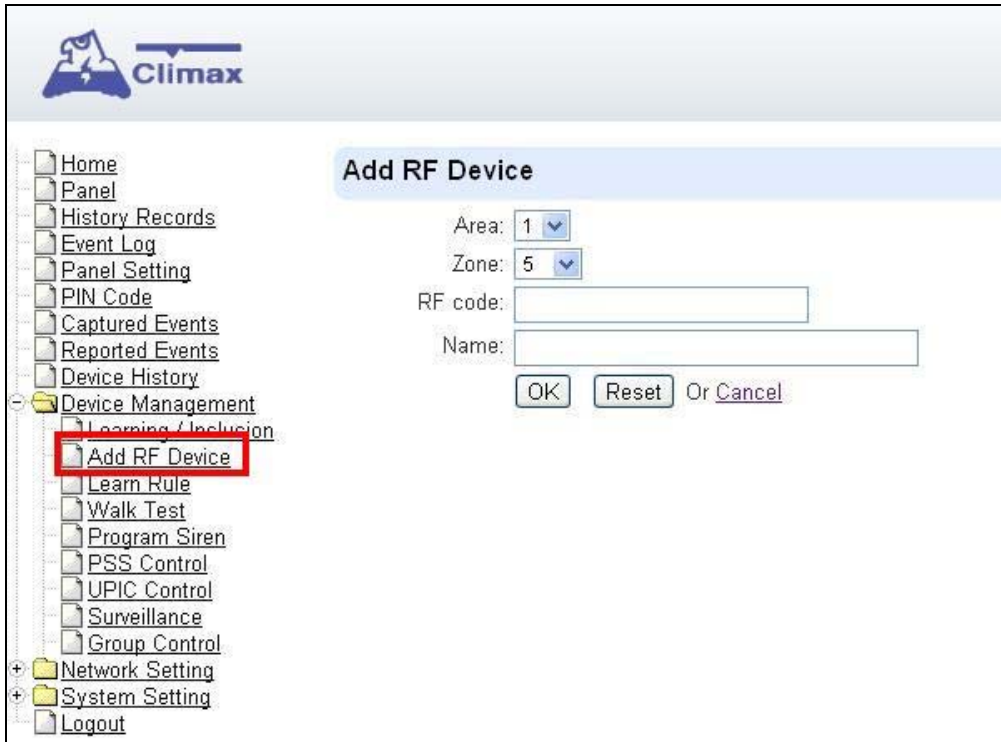

Step 2. Select Area and Zone number for the device you wish to add into system.

Step 3. Enter the device RF code, and preferred device name (up to 31 characters)

Step 4. Press "OK" to save

Step 5. If the RF code you entered is valid, the device will be added into the system according to the Area and Zone number. You do not need to learn the device as instructed in **5.1.1. Add Sensor**.

5.3. Learn Rule

You can enter the sensor RF code or ZigBee MAC address manually to assign area and zone number to this sensor. Sensors learned with pre-assigned rule will be put under the area and zone number you specified. This function does not work with Z-Wave devices and DECT device.

Step 1. Click **Learn Rule**.

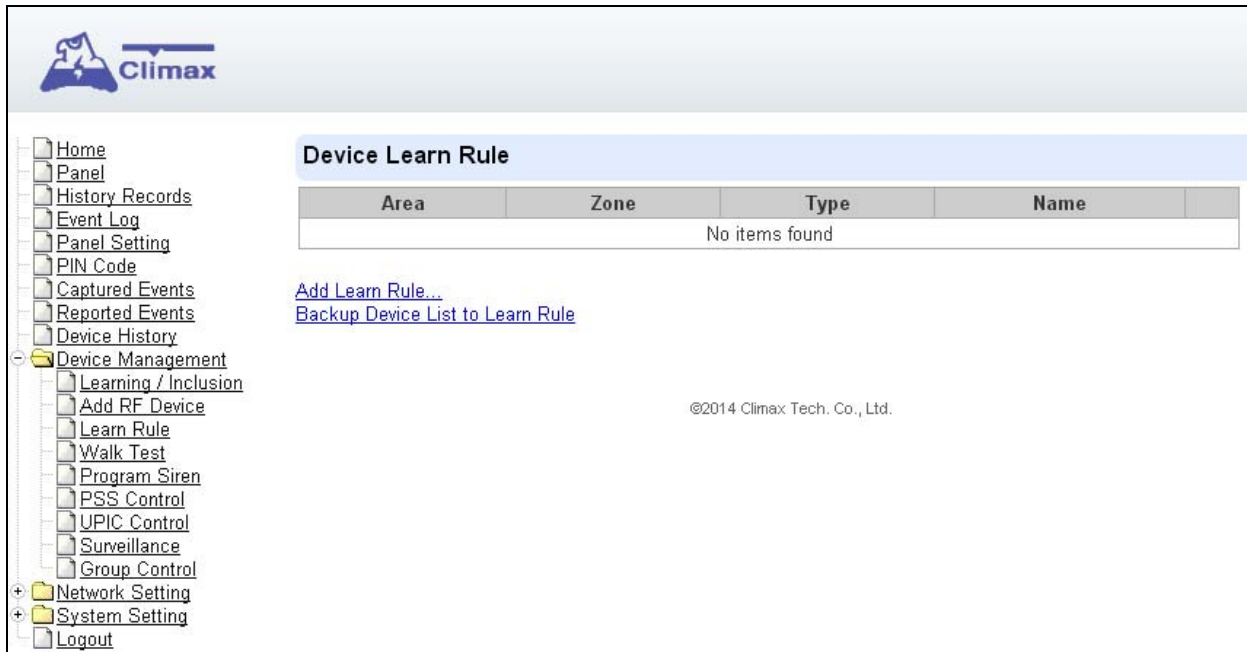

Step 2. You will see the **Add Learn Rule** menu.

Step 3. Select **Area** and **Zone** number for this device.

Step 4. Select **RF** or **ZigBee**.

Step 5. Key in the RF code or ZigBee MAC info

Step 6. For ZigBee device, select a ZigBee Device Type

Step 7. Enter a preferred name for sensor (up to 31 letters or numbers).

Step 8. Press “OK” to save.

Step 9. If the process is successful, the screen will display “**Updated Successfully.**” You can then check, edit or delete the rule under the **Learn Rule** menu.

Step 10 Repeat the steps to add more rules.

Step 11. Learn in the sensors you have entered rules for according to **5.1.1 Add Sensor**.

<NOTE>

- ☞ Learn rule function is only used to pre-assign area and zone number to sensors before learning. To add sensor to control panel, you still need to follow the instruction in **5.1.1 Add Sensor** to complete the learning process.

- **Backup Device List to Learn Rule**

You can choose to import learn rule from current learnt in ZigBee devices

Step 1. Click “Backup Device List to Learn Rule”.

Step 2. Click OK to confirm.

Step 3. The Learn Rule page will be updated with new rules according to current ZigBee device list information. Z-wave device and IP Camera will not be included.

5.4. Walk Test

This is to test the sensor operation range for installation purpose.

Step 1. Click on “**Start**”. The Control Panel LED 1 & LED 2 Green Flash is now in Walk Test mode. The system will automatically exit the test mode after 5 minutes



Step 2. Press the test button on the sensor(s) or any button on the Remote Controller or triggering the sensor.

Step 3. When the Control Panel receives a signal, it will show as below and a 2-tone beep will be heard to indicate that it is safe to install the particular sensor in the location.

- **Time:** time information
- **Area:** operation area
- **Zone:** device zone
- **Type:** device type
- **Name:** device name
- **Rssi:** the RF signal strength between Control Panel and sensor. The Rssi value here must be higher than the Rssi value of Panel's background noise (please refer to 6.1 *Panel Condition* section for details). If not, you may still learn in the sensor; however, please relocate the sensor and use Walk test to find a more suitable location.
- **DeviceID:** device's unique identification code.

Step 4. Once all sensors are tested, click on “**Stop**” to exit Walk Test mode.

5.5. Program Siren

The Program Siren page include siren learning and setting configuration function.

The screenshot shows the Climax web interface for the 'Program Siren' configuration page. On the left is a navigation tree with 'System Setting' selected. The main content area is titled 'Program Siren' and contains three sections: 'Learn Siren', 'Siren Setup', and a detailed configuration section. The 'Learn Siren' section has an 'Option' dropdown set to 'All' and a 'Learn Siren' button. The 'Siren Setup' section has three radio button options: 'Siren Tamper On' (selected), 'Siren Tamper Off', 'Confirm On' (selected), 'Confirm Off', and 'Entry Sound On' (selected), 'Entry Sound Off'. Each has a corresponding button. The detailed configuration section includes dropdowns for 'Area' (1) and 'Zone' (1), and volume dropdowns for 'Alarm volume' (High), 'Exit/Confirm arm volume' (High), and 'Entry/Confirm disarm volume' (High). Other settings include 'Door chime', 'Burglar trigger in home arm', 'Burglar trigger in away arm', 'Strobe activation', 'Confirm flash', 'Exit flash', 'Entry flash', and 'Trigger flash', all set to 'On'. A 'Submit' button is at the bottom.

- **Learn Siren**

<NOTE>

☞ The Learn Siren function is designed for single way radio siren (BX-7,8 and SR-7,8) only. To learn in two-way sirens, please refer to the **5.1 Learning** section.

Step 1. Select the **Option** drop-down menu, choose from **All**, **Area1**, and **Area2** to determine which area should the siren below to.

Step 2. Put your Bell Box or Indoor Siren in **Learning Mode** (Slide BX/SR dip switch 1 to **ON**. For more details, please refer to siren manual for detail).

Step 3. Click **Learn Siren** to transmit learn code, refer to BX/SR manual to complete learning.

- **Siren Setup**

- **Siren Tamper On/Off**

You can enable/disable the siren's tamper protection with this function. Select to turn on or off the siren's tamper function then click "**Siren Tamper**" to confirm.

<NOTE>

☞ When turned off, if siren tamper will be enabled again automatically after one hour if not turn on manually during the one hour period.

- **Confirm On/Off**

When turned on the siren will emit confirmation beep when the control panel mode is changed. When turned off, the siren will remain silent. Select to turn on or off the confirmation function, then click "**Siren Tamper**" to confirm.

- **Entry Sound On/Off**

When turned on the siren will emit beeps during entry and exit timer. When turned off, the siren will remain silent. Select to turn on or off the entry sound function, then click "**Siren Tamper**" to confirm.

- **Siren Setting:**

Choose to edit individual siren detail setting with the slide down menus. Refer to siren manual for available options. After finish all settings, click "**Submit**" to confirm.

5.6. Exclusion

This feature is only available for HPGWL-5 and HPGW-G5, or when a Z-wave dongle is inserted into the Control Panel. This feature is for you to remove Z-Wave device only.

Step 1. Click on “**Exclusion**” and click on “**Start**” to start the procedure. Then the Panel will enter the removing mode.



Step 2. Refer to the Z-Wave device manual to transmit signal.

Step 3. Select the desired Z-Wave and click **delete** to remove it from the Z-wave list under **Device List** section (**Panel**). Then the Control Panel will remove the Z-Wave device.

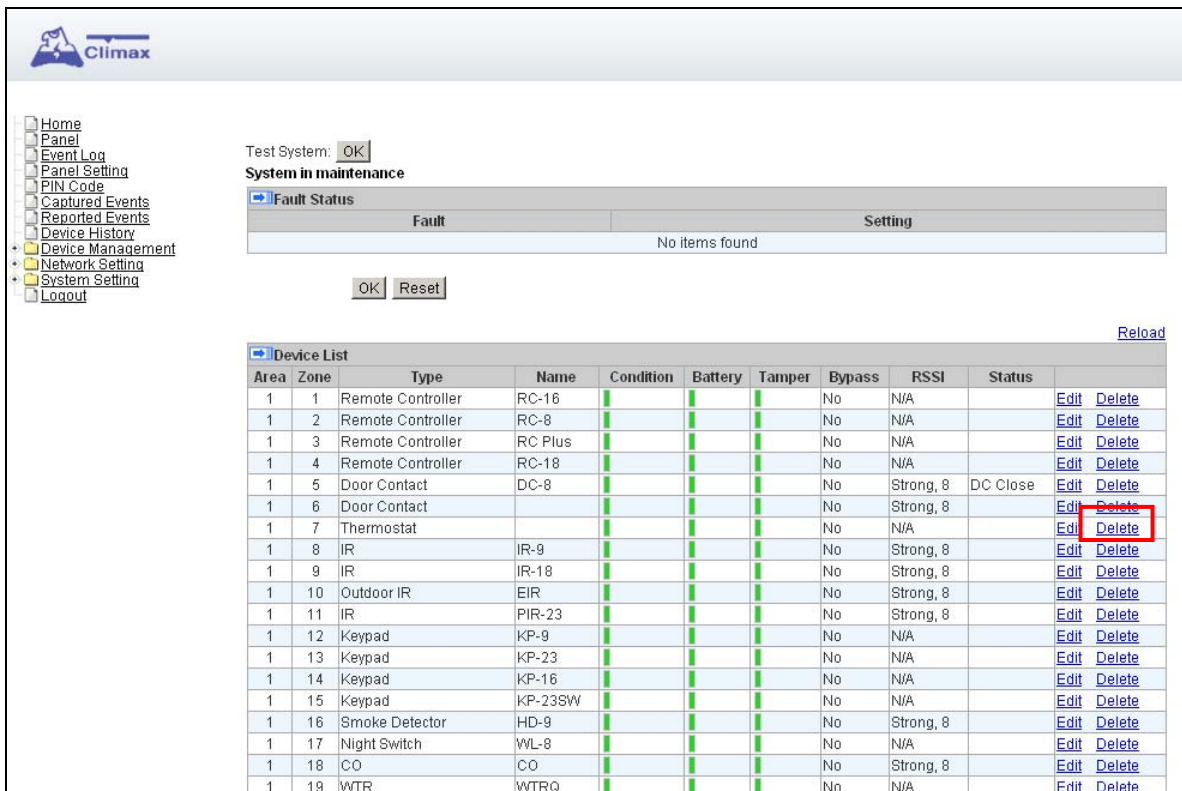

5.7. Z-Wave Tool

This feature is only available when Z-Wave dongle is inserted. This feature is for you to reset the Z-Wave dongle to factory default and remove all Z-Wave devices, or change routing setting.

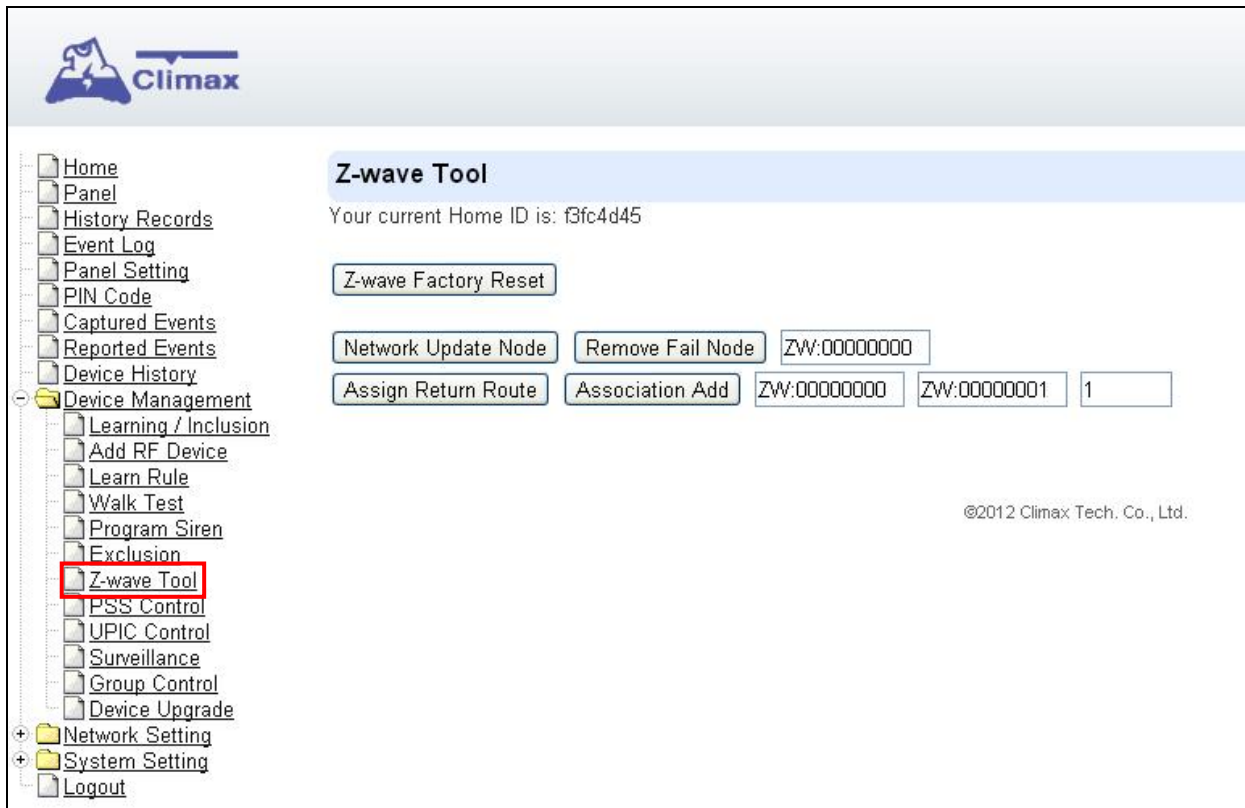

● Reset Z-Wave Dongle

Step 1. Click "Z-Wave Factory Reset", Then the inserted Z-Wave dongle is reset to factory default and all Z-Wave devices will be removed automatically. The Control Panel Home ID will also be changed automatically for a newly added Z-Wave device to recognize.

Step 2. The list of Z-Wave devices is still displayed in the **Panel**. Please go to **Panel** and then **Device List**. Press **Delete** button to remove them one by one.

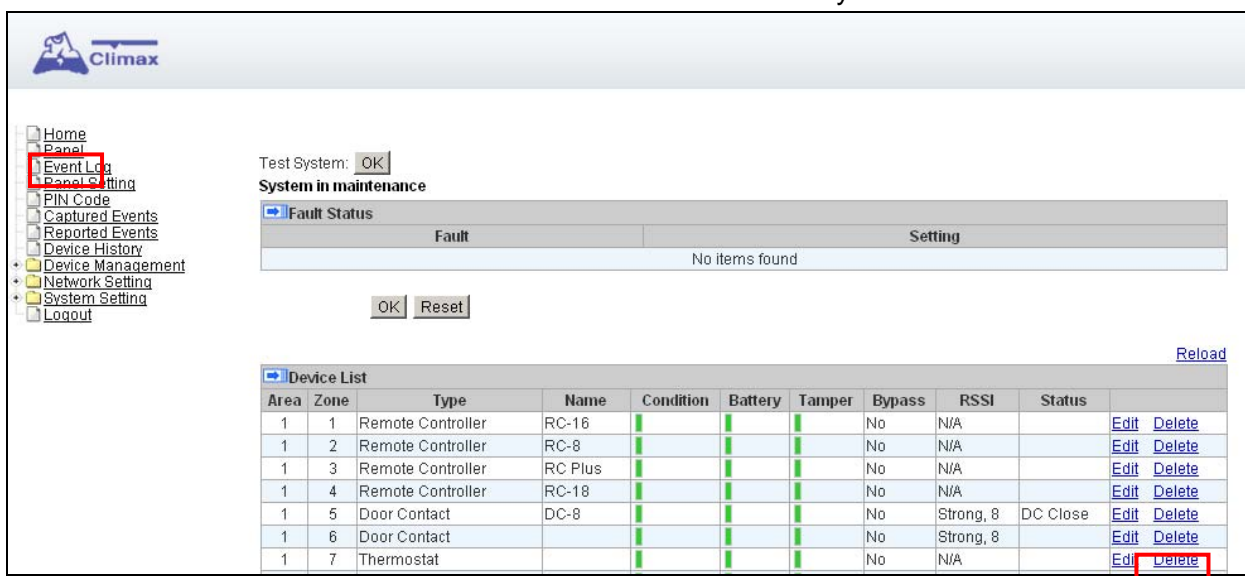

● Change Z-Wave Routing Setting

Use the other functions to configure your Z-Wave routing settings.

5.8. PSS Control

This feature is designed to control/edit/delete Power Switches included in the panel.



The screenshot displays the Climax web interface. On the left is a navigation menu with items like Home, Panel, Event Log, Panel Setting, PIN Code, Captured Events, Reported Events, Device History, Device Management (expanded), Learning / Inclusion, Add Device, Walk Test, Program Siren, **PSS Control** (highlighted with a red box), UPIC Control, Surveillance, Group Control, Network Setting, System Setting, and Logout. The main content area is titled 'Power Switch Sensor' and contains a table with the following data:

Area	Zone	Type	Name	Status	
1	1	Power Switch Meter		Off, 0.0W	Edit Delete Switch On Switch Off Switch Toggle

©2011 Climax Tech. Co., Ltd.

- Click **Edit** to edit attributes of power switches.
- Click **Delete** to remove power switch from panel.
- Click **Switch On/Switch Off** to turn on/off power switches. Or click **Switch Toggle** to toggle between on/off status. For Power Switch Dimmer, you can also set its power output level with the slide down menu.

5.9. UPIC Control

UPIC Control webpage allows you to control UPIC IR Transmitter included in Control Panel

The screenshot shows the Climax UPIC Control interface. On the left is a navigation tree with 'UPIC Control' highlighted. The main area has a table for device settings:

Area	Zone	Type	Name
1	1	UPIC	Off

Below the table are settings for various appliances: Air Conditioner (1), TV (1), Home Audio (1), Set-top Box (1), and Others (1). A 'Setup UPIC' button is present. Below this is a diagram of the UPIC5 LEDs, consisting of a central LED (1) and five surrounding LEDs (2, 3, 4, 5).

● Transmit IR Signal

Depending on the UPIC model number, select the function to be performed in the drop down menu, then click “Setup UPIC” for the UPIC to transmit IR Signal.

● UPIC5 LED Setup (UPIC5 only)

UPIC5 has 6 IR LEDs, a central one and 5 surrounding ones. The central LED will always transmit IR signal when activated; besides the central LED, one of the 5 surrounding LEDs can be selected to activate upon IR signal transmission to increase the IR signal coverage.

Step 1: Refer to the diagram on the webpage and UPIC5 manual to determine which LED should be used for signal transmission to each particular home appliance.

Step 2: Select the LED number from the drop down menu for each appliance type, then click “Setup LED” to confirm. Please refer to UPIC5 manual for more information.

<EXAMPLE>

- ☞ If “Air Conditioner” is set to LED 1, UPIC5 will transmit all Air Condition functions with both Central LED and LED1.
- ☞ If “TV” is set to LED 5, UPIC5 will transmit all Air Condition functions with both Central LED and LED5.

5.10. Surveillance

The PIR Camera/Video Cameras and IP Cameras are listed under **Surveillance** for separate control.



Area	Zone	Type	Name				
1	2	IR Camera		Edit	Delete	Request Media	Request Media (No Flash)
1	9	IP Camera		Edit	Delete	Request Media	View Setting

- Click **Edit** to edit camera attributes.
- Click **Delete** to remove device from panel.
- Click **Request Media** to capture a picture or vide
 - PIR camera: A picture will be captured upon request
 - PIR Video Camera: A 10-second video will be recorded upon request
 - IP Camera: The IP Camera will record a video according to its video length setting (Please refer to IP Camera manual for detail.)
 - For PIR Camera/Video Camera, you can choose to take the picture/video without activating the camera's flash.

Picture and video captured by PIR Camera and PIR Video Camera will be stored under the **Captured Event** webpage. Video Recorded by IP Camera will be stored in the IP Camera, please refer to IP Camera manual to view the video

- For IP Camera, click "View" or "Setting" to access IP Camera webpage for video streaming or setting configuration. A new webpage will open and you will be required to enter the username and password for the IP Camera to access streaming or setting.

5.11. Group Control

This feature is designed for you to edit a name of group, switch on or off a group of Power Switches. You can also assign Power Switches to groups you desire.

5.11.1. Group Control/Edit

Step 1. Specify a new name for a group.

The screenshot shows the Climax web interface. On the left is a navigation menu with items like Home, Panel, History Records, Event Log, Panel Setting, PIN Code, Captured Events, Reported Events, Device History, Device Management, Learning / Inclusion, Add RF Device, Learn Rule, Walk Test, Program Siren, PSS Control, UPIC Control, Surveillance, Group Control, Network Setting, System Setting, and Logout. The 'Group Control' item is highlighted with a red box. The main content area is divided into two sections: 'Group List' and 'Device List'. The 'Group List' section contains a table with 8 rows. The first row has a red box around the 'Name' input field and another red box around the 'Switch On' and 'Switch Off' buttons. The 'Device List' section contains a table with 13 columns: Area, Zone, Type, Name, Group 1, Group 2, Group 3, Group 4, Group 5, Group 6, Group 7, Group 8, Edit, and Delete. The first row shows Area 1, Zone 4, Type Power Switch Meter, and checkboxes for Groups 1 through 8. There are 'OK' and 'Reset' buttons below both tables.

Group	Name	Switch On	Switch Off
1	<input type="text"/>	Switch On	Switch Off
2	<input type="text"/>	Switch On	Switch Off
3	<input type="text"/>	Switch On	Switch Off
4	<input type="text"/>	Switch On	Switch Off
5	<input type="text"/>	Switch On	Switch Off
6	<input type="text"/>	Switch On	Switch Off
7	<input type="text"/>	Switch On	Switch Off
8	<input type="text"/>	Switch On	Switch Off

Area	Zone	Type	Name	Group 1	Group 2	Group 3	Group 4	Group 5	Group 6	Group 7	Group 8	Edit	Delete
1	4	Power Switch Meter		<input type="checkbox"/>	<input type="checkbox"/>	<input type="checkbox"/>	<input type="checkbox"/>	<input type="checkbox"/>	<input type="checkbox"/>	<input type="checkbox"/>	<input type="checkbox"/>	Edit	Delete

Step 2. Click Switch On or Switch Off to turn on or off one group of power switches.

5.11.2 Device Edit/Delete

Step 1. Check on the groups you wish to assign the Power Switch. This is a multiple-choice field and you can assign one Power Switch to multiple groups. Whenever one of the assigned groups receives request to turn on/off, all Power Switches belonging to the group will be activated accordingly.

The screenshot shows the 'Device List' section of the Climax web interface. It features a table with 13 columns: Area, Zone, Type, Name, Group 1, Group 2, Group 3, Group 4, Group 5, Group 6, Group 7, Group 8, Edit, and Delete. The first row shows Area 1, Zone 1, Type Power Switch Meter, and checkboxes for Groups 1 through 8. The checkbox for Group 1 is checked. There are 'OK' and 'Reset' buttons below the table.

Area	Zone	Type	Name	Group 1	Group 2	Group 3	Group 4	Group 5	Group 6	Group 7	Group 8	Edit	Delete
1	1	Power Switch Meter		<input checked="" type="checkbox"/>	<input type="checkbox"/>	<input type="checkbox"/>	<input type="checkbox"/>	<input type="checkbox"/>	<input type="checkbox"/>	<input type="checkbox"/>	<input type="checkbox"/>	Edit	Delete

Step 2. Click **Edit** to edit attributes of an added power switch or power switch meter or **Delete** to delete this device.

6. Program the System

After the initial set-up, you can then program your system by clicking on the left menu to set them individually.

6.1. Panel Condition

In the **Panel** Section, user can arm, disarm or partially arm the system. Besides, it displays the current **Panel Status & Device Information**.

Panel Control

Area 1
Current mode: Disarm
 Disarm Full Arm Home Arm 1 Home Arm 2 Home Arm 3

Area 2
Current mode: Disarm
 Disarm Full Arm Home Arm 1 Home Arm 2 Home Arm 3

Panel Status

Battery	Tamper	Interference	AC activation	Signal GSM	Background RSSI
Normal	Normal	Normal	Normal	9	1

Test System:

System in maintenance

Fault Status

Fault	Setting
Area1Zone6 Tamper	<input checked="" type="checkbox"/> Clear

[Reload](#)

Device List

Area	Zone	Type	Name	Condition	Battery	Tamper	Bypass	RSSI	Status	
1	1	Keypad		Normal	Normal	Normal	No	Strong		Edit Delete
1	2	Remote Controller		Normal	Normal	Normal	No	Strong		Edit Delete
1	3	WTRV		Normal	Normal	Normal	No	N/A		Edit Delete
1	4	IR Camera		Normal	Normal	Normal	No	Good		Edit Delete
1	5	809		Normal	Normal	Normal	No	Strong		Edit Delete
1	6	Door Contact		Normal	Normal	Tamper	No	Strong	DC Open	Edit Delete

Panel Control

Select a choice to arm, disarm or partially arm the system.

Panel Status

The Control Panel will update the panel status periodically. However, in order to show the current status, you must reload the screen to refresh the display.

- **Battery:** When battery is running low, a “low battery” message will be displayed to

inform you to recharge the battery.

- **Tamper:** (reserved)
- **Interference:** This is for you to check whether the Control Panel is purposely interfered. Whenever the signal jamming period lasts longer than 30 seconds, a “Jamming” message will be shown and reported to the Central Monitoring Station accordingly.
- **AC activation:** To check whether AC power is connected. If not, it will show “AC Failure”.
- **Signal GSM:** GSM signal value is for you to check the GSM signal strength around the Control Panel. It ranges from 0 to 9, where 0 refers to the weakest and 9 refers to the strongest one. The higher the value, the better the GSM signal strength.
- **Background RSSI:** Rssi value is for you to check the RF environment around the Control Panel. It ranges from 0 to 9, where 0 refers to the weakest and 9 refers to the strongest background noise. Therefore, the lower the Rssi value, the better the environment.

Test System

The function is designed to send a command to sever over the polling or XMPP protocol.

Fault Status

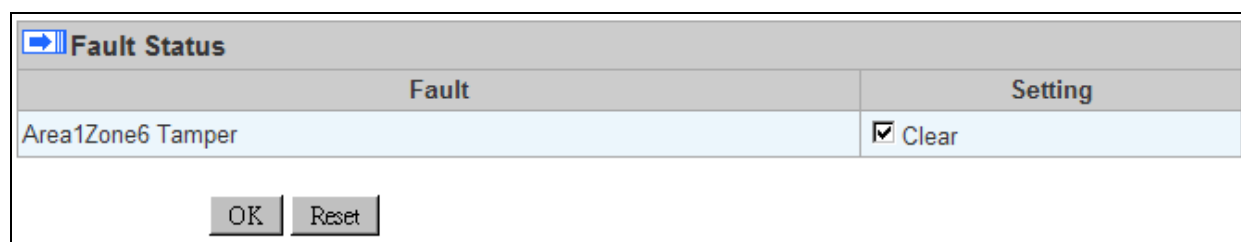

Fault	Setting
Area1Zone6 Tamper	<input checked="" type="checkbox"/> Clear

OK Reset

The fault events that exist in the alarm system is displayed under this section. When fault event exists in system, the control panel Fault LED will light up to indicate fault status under Disarm or Home Arm mode (The Fault LED will not light up under Arm mode).

When fault event exists, and you attempt to arm the system, the arming action will be prohibited and the panel will display fault information on the webpage. If you still want to arm the system, perform the arming action again to force arm.

You can check the “Clear” box in the setting column then click “OK” to ignore the fault event. Cleared fault event will not cause the Fault LED to light up, nor prohibit arming.

Device List

1. The Control Panel will update the device information periodically. However, in order to show the current status, you must **reload** the screen to refresh the display.

➤ **Area:** operation area

- **Zone:** device zone
- **Type:** device type
- **Name:** device title
- **Status:** device’s current status, such as tamper status, battery status, out of order condition or DC open. If PSM is added into the system, the data of PSM, such as On/Off status, voltage, electric current and watt, will be displayed.

2. Under **Device**, you could further **edit** or **delete** an added device (please refer to **5.1.3** and **5.1.4** for details). Beside, you can reset Panel settings or clear the system faults by pressing **Reset Panel**.

Device List										
Area	Zone	Type	Name	Condition	Battery	Tamper	Bypass	RSSI	Status	
1	2	UPIC					No	Strong, 7		Edit Delete
1	3	IR					No	Strong, 8		Edit Delete
1	6	Keypad					No	Strong, 6		Edit Delete

- After pressing **Reset Panel**, the Control Panel will restart in 60 seconds and all configured values will be kept without any change.

Note

Note			
No.	Type	Description	
#1			Edit
#2			Edit
#3			Edit
#4			Edit
#5			Edit

The function is designed for installer to make a note for each control panel. The note you make here can be delivered to a server over XMPP or polling protocol.

6.2. Panel Settings

Program the **Panel**, **Time** and **Sound Settings** at your discretion.

Panel Setting

AC Fail Report 5 min ▼
 AC Fail Suspend 5 sec ▼
 Jamming Report 1 min ▼
 Auto Check-in Interval 12 hr ▼
 Auto Check-in Offset Period 1 hr ▼
 IR Camera Resolution of Alarm Images 320x240x3 images ▼
 Outdoor IR Camera in Grayscale Disable ▼
 OK Reset

Area Setting

Area 1 ▼
 Final Door Off ▼
 Arm Fault Type Confirm ▼
 Tamper Alarm Full Arm ▼
 Supervision Check On ▼

Time Setting

Supervision Timer 12 hr ▼
 Entry Delay 1 for Full Arm Disable ▼
 Entry Delay 2 for Full Arm Disable ▼
 Exit Delay for Full Arm Disable ▼
 Entry Delay 1 for Home Arm Disable ▼
 Entry Delay 2 for Home Arm Disable ▼
 Exit Delay for Home Arm Disable ▼
 Alarm Length 3 min ▼

Sound Setting

Door Chime Setting Off Low High
 Entry Delay Sound for Full Arm Off Low High
 Exit Delay Sound for Full Arm Off Low High
 Entry Delay Sound for Home Arm Off Low High
 Exit Delay Sound for Home Arm Off Low High
 Warning beep Off Low High
 Entry/Exit Only Final Beeps Disable ▼
 OK Reset

Panel Setting

- **AC Fail Report:** Set the waiting time before Control Panel report to Central Monitoring Station when AC failure is detected.
- **AC Fail Suspend:** After AC failure is detected, the panel will enter sleeping mode and wake up at regular interval. Use this option to set the wake up period duration.
- **Jamming Report:** this function is reserved.
- **Auto Check-in:** this is to select whether the Control Panel needs to send check-in

reporting to the Central Station automatically and to select the period of time between check-in reports. Options available are **Disable, 1 hour, 2 hours, 3 hours... up to 4 Weeks**.

- **Auto Check-in Offset Period:** This is to set the time delay before the first **Auto Check-In** report is made. After power is supplied or re-supplied to the Control Panel, a test report will be sent to the Central Monitoring Station (CMS) based on the Offset Period. This is used to test whether the CMS is able to receive the report from the Panel accurately.

After this test report is sent, the Control Panel will then send reports at regular interval based on the setting of the Auto Check-in Report.

For example, if **Offset Period** is set to 2 Hours, and **Auto Check-in Report** is set to 12 hours, the Control Panel will transmit an event code 602 to the CMS after 2 hours, and then report 602 event code periodically at a regular intervals of 12 hours.

- **IR Camera Resolution of Alarm Images:** This is to select the resolution and number of pictures taken by PIR Camera when the camera detects a movement in armed mode.

Options available are **320x240x3 images (Default), 320x240x6 images and 640x320x3 images**.

- **Outdoor IR Camera in Greyscale:** This is to select whether pictures from Outdoor PIR Camera should be taken in greyscale instead of color pictures.

Options available are: **Disable**(Color Picture) and **Enable** (Greyscale picture)

Area Setting

- **Area:** Select operation area to apply setting.
- **Final Door:** If set to **On:** When the system is Away Armed and under exit timer countdown, if a opened Door Contact set to Entry attribute is closed, the system will automatically arm the system even if the exit delay timer has not expired yet.
- **Arm Fault Type:** Select how the system should respond when it is being armed under fault condition.
 - ✓ Confirm: The panel will first display a "Mode Change Fault" message and emit 2 beeps. Arming again within 10 seconds will force arm the system.
 - ✓ Direct Confirm: The system will be force armed directly without displaying fault message and report an event.
- **Tamper Alarm:** Select whether the siren should sound alarm when the tamper is triggered.
 - ✓ Full Arm: when tamper is triggered under Full arm mode, Control Panel raises a local alarm and sends report to the monitoring center. While under Home Arm or Disarm modes no alarm will be activated, nor report sent.
 - ✓ Always: Control Panel raises a local alarm and send report for tamper-trigger in all modes.
- **Supervision Check:** Select to enable or disable system supervision function. When **ON** is selected, the Control Panel will monitor the accessory devices according to the supervision signal received.

Time Setting

- **Supervision Timer:** The Control Panel monitors accessory devices according to the supervision signal transmitted regularly from the device. User this option to set a time period for receiving supervision signals. If the Control Panel fails to receive supervision signal from a device within this duration, it will consider the device out of order and report the event accordingly.

- **Entry Delay 1 for Full Arm:** Set Entry Delay Timer 1 for full arm mode. When a sensor set to Start Entry Delay 1 is triggered under Full Arm mode, the control panel will begin Entry Delay Timer countdown according to duration set with this option
 If the Control Panel is disarmed before the Entry Delay Timer expires, the panel returns to Disarm mode and no alarm is activated. If the Control Panel is not disarmed before the Entry Delay Timer expires, the alarm will be activated and the panel will send report.
- **Entry Delay 2 for Full Arm:** Set Entry Delay Timer 2 for full arm mode. When a sensor set to Start Entry Delay 2 is triggered under Full Arm mode, the control panel will begin Entry Delay Timer countdown according to duration set with this option
 If the Control Panel is disarmed before the Entry Delay Timer expires, the panel returns to Disarm mode and no alarm is activated. If the Control Panel is not disarmed before the Entry Delay Timer expires, the alarm will be activated and the panel will send report.
- **Exit Delay for Full Arm:** Set the Exit Delay Timer when entering Full Arm mode. When the user changes system mode to Full Arm, the panel will begin Exit Delay Timer Countdown and enter Full Arm mode when the timer expires. The user must leave area protected by sensors before the timer expires, otherwise an alarm will be activated with the sensor is triggered.
- **Entry Delay 1 for Home Arm:** Set Entry Delay Timer 1 for Home Arm mode. When a sensor set to Start Entry Delay 1 is triggered under Home Arm mode, the control panel will begin Entry Delay Timer countdown according to duration set with this option
 If the Control Panel is disarmed before the Entry Delay Timer expires, the panel returns to Disarm mode and no alarm is activated. If the Control Panel is not disarmed before the Entry Delay Timer expires, the alarm will be activated and the panel will send report.
- **Entry Delay 2 for Home Arm:** Set Entry Delay Timer 2 for Home Arm mode. When a sensor set to Start Entry Delay 2 is triggered under Home Arm mode, the control panel will begin Entry Delay Timer countdown according to duration set with this option
 If the Control Panel is disarmed before the Entry Delay Timer expires, the panel returns to Disarm mode and no alarm is activated. If the Control Panel is not disarmed before the Entry Delay Timer expires, the alarm will be activated and the panel will send report.
- **Alarm Length:** Set the duration the external siren should sound when an alarm is activated.

Sound Setting

- **Door Chime Setting:** this function is available only when the attribute of Door Contact (DC) and/or PIR detector (IR) is set as **Door Chime**.
 The Control Panel sounds a Door Chime (Ding-Dong Sound) while the DC and/or IR is activated in Disarm / Full / Home / Entry mode.
- **Entry Delay Sound for Full Arm:** this is for you to decide whether the Control Panel sounds count-down beeps and volume of beep during the entry delay time in the full arm mode.
- **Exit Delay Sound for Full Arm:** this is for you to decide whether the Control Panel sounds count-down beeps and volume of beep during the exit delay timer in the full arm mode.
- **Entry Delay Sound for Home Arm:** this is for you to decide whether the Control Panel sounds count-down beeps and volume of beep during the entry delay time in the home arm mode.
- **Exit Delay Sound for Home Arm:** this is for you to decide whether the Control Panel sounds count-down beeps and volume of beep during the exit delay timer in the home arm mode.
- **Warning beep:** this is for you to decide whether the Control Panel will sound a warning

beep whenever a fault condition has been detected and displayed. The warning beep will be silenced after the Fault message has been read by the user. When a new fault condition is detected, it will then again emit a warning beep every 30 sec.

- **Entry/ Exit Only Final Beeps:** This is for you to determine when the Control Panel should start warning beep during Entry or Exit countdown timer. For example, if the setting is set to 5 seconds, the Control Panel will only start warning beep during the last 5 seconds of Entry or Exit countdown timer. When set to Disable, the Control Panel will sound warning beep during the entire Entry or Exit countdown timer.

6.3. PIN Code

The User PIN Codes are used by Remote Keypad accessory to control system mode remotely. The 2 areas in the control panel each has 6 User PIN Codes available for setting. Each consists of 4 digits (numeric number 0~9). User PIN code #1 for each Area is always activated factory default.

User PIN #1 in Area 1

Password: **1234**

User PIN #1 in Area 2

Password: **4321**

No.	User Code	User Name	Latch	Delete
1.	1234	user	<input checked="" type="checkbox"/>	<input type="checkbox"/>
2.			<input type="checkbox"/>	<input type="checkbox"/>
3.			<input type="checkbox"/>	<input type="checkbox"/>
4.			<input type="checkbox"/>	<input type="checkbox"/>
5.			<input type="checkbox"/>	<input type="checkbox"/>
6.			<input type="checkbox"/>	<input type="checkbox"/>

Area

Area: Select the area for setting User PIN Code.

User Code Setting

- **User Code:** Enter the 4-digit code in the field.
- **User Name:** Enter a user name for easy recognition of system events. Up to 17 alphanumeric characters are allow for each user Name.
- **Latch:**
 - Latch → **Latch Report ON** = Whenever the User PIN Code is used to change system mode, the panel will report the event.
 - Latch → **Latch Report OFF** = When the User PIN Code is used to change system mode, the panel will not report the event.
- **Delete:** Check the box if you want to delete selected user. User#1 in each area cannot be deleted

After finish all setting, click **OK** to confirm change.

7. Network Settings

7.1. GSM (HPGWL-2/3/5 and HPGW-G2/3/5 only)

The screenshot shows the Climax web interface for network settings. The left sidebar contains a tree view with the following items: Home, Panel, History Records, Event Log, Panel Setting, PIN Code, Captured Events, Reported Events, Device History, Device Management, Network Setting (expanded), GSM (highlighted with a red box), Network, UPnP, System Setting, and Logout. The main content area is titled 'GSM' and contains the following sections:

- GSM**: Insert SIM. Check SIM: Test present of SIM card No Yes. Buttons: OK, Reset.
- GPRS**: APN, User, Password. Buttons: OK, Reset.
- MMS**: APN, User, Password, URL, Proxy Address, Proxy Port (8080). Buttons: OK, Reset.
- SMS**: SMS Keyword, SMS P-word (PROG). Buttons: OK, Reset.
- Two-Way Setting**: Speaker (9), Microphone (7). Buttons: OK, Reset.

At the bottom of the interface, there are links for [Send SMS...](#) and a [GSM Reset](#) button.

Check SIM

This is designed for the system to check the SIM card or not. (***If users do not intend to use the GSM function, please tick "NO" to ensure the system will not check if the SIM card is inserted or not and it will not display the GSM fault by LED flashing.***)

GPRS

In order to allow GPRS to serve as a back-up IP Reporting method, this section will need to be programmed before reporting.

- **APN (Access Point) Name**

It is the name of an access point for GPRS. Please inquire your service provider for an APN. When APN is set, the system becomes valid for internet connection.

- **User (GPRS)**

It is the Log-in name to input before accessing the GPRS feature. Please inquire your service provider.

- **Password (GPRS)**

It is the User Password to input before accessing the GPRS feature. Please inquire your service provider.

<NOTE>

☞ All values will be applied to both Areas 1 & 2.

MMS

The MMS settings are offered by your telecom service provider. Before configuring this function, contact your service provider for correct MMS setting information of the inserted SIM card.

- **APN (Access Point) Name**

Enter a MMS APN name provided by your service provider.

- **User**

Enter the Log-in name for accessing the MMS feature provided by your telecom service provider.

- **Password**

Enter the password for accessing the MMS feature provided by your telecom service provider.

- **URL**

Enter the MMS APN URL provided by your telecom service provider.

- **Proxy Address**

Enter the MMS Proxy Address provided by your telecom service provider.

- **Proxy Port**

Enter the MMS Proxy Port provided by your telecom service provider.

SMS

- **SMS Keyword**

For sending remote commands to system via SMS message, a personalized password is required for the Control Panel to recognize your authority.

- **SMS P-Word**

Program Keyword is used to recognize the identity of a valid user; and to give authority for Remote Installing (through SMS Text) or Remote Upgrading purposes (through GPRS). This keyword will need to be inserted whenever the Remote Setting or Remote Upgrading is required. A maximum of 15 characters is allowed.

Two Way Setting

The two-way setting is designed to adjust speaker volume and microphone sensitivity on DECT device for two-way communication.

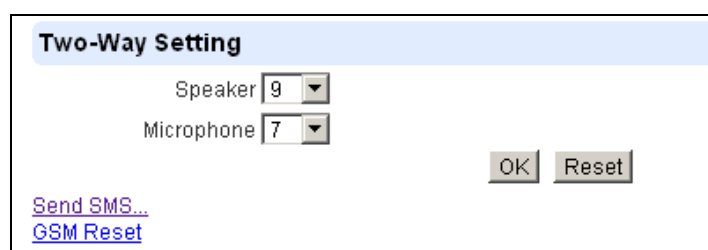

Send SMS Message

This feature is designed for you to send a SMS message on this web configuration page.

Step 1. Click Send SMS.

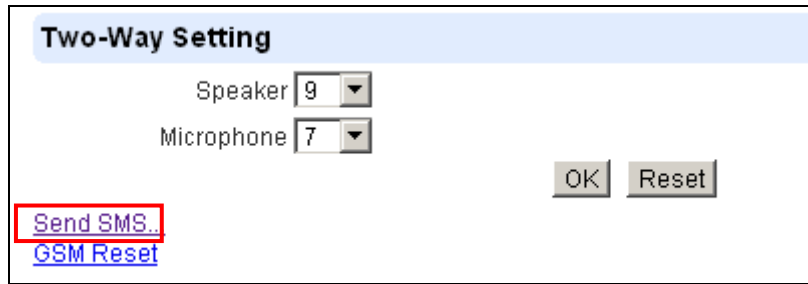

The screenshot shows a 'Two-Way Setting' menu. At the top, there is a blue header with the text 'Two-Way Setting'. Below the header, there are two dropdown menus: 'Speaker' with the value '9' and 'Microphone' with the value '7'. To the right of these are two buttons: 'OK' and 'Reset'. At the bottom left, there are two links: 'Send SMS..' (highlighted with a red box) and 'GSM Reset'.

Step 2. Enter a desired phone number and text message.

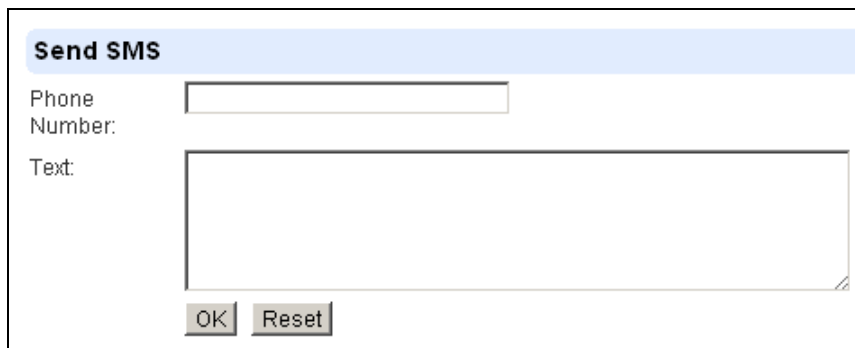

The screenshot shows a 'Send SMS' form. At the top, there is a blue header with the text 'Send SMS'. Below the header, there are two input fields: 'Phone Number:' with a text box and 'Text:' with a larger text area. At the bottom, there are two buttons: 'OK' and 'Reset'.

Reset GSM

This feature is designed for you to reset GSM module.

Step 1. Click GSM Reset.

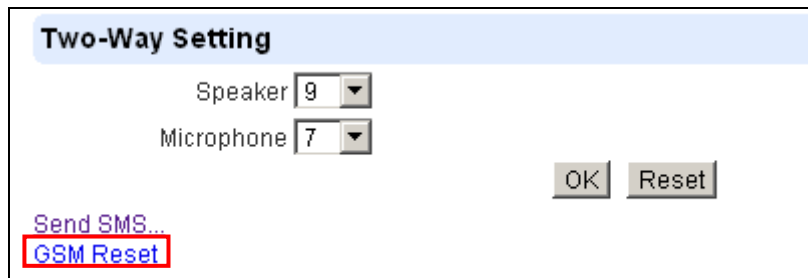

The screenshot shows a 'Two-Way Setting' menu. At the top, there is a blue header with the text 'Two-Way Setting'. Below the header, there are two dropdown menus: 'Speaker' with the value '9' and 'Microphone' with the value '7'. To the right of these are two buttons: 'OK' and 'Reset'. At the bottom left, there are two links: 'Send SMS...' and 'GSM Reset' (highlighted with a red box).

Step 2. A pop-out message "Are you sure?" is displayed. Click Yes to confirm resetting.

7.2. Network

This is for you to program the Network for IP connection.

The screenshot shows the 'Network' configuration page in the Climax web interface. The sidebar on the left lists various settings, with 'Network' highlighted. The main content area has a title 'Network' and two radio button options. The first option, 'Obtain an IP address automatically (DHCP)', is selected. The second option, 'Use the following IP address', is unselected. Below these options are several input fields for manual configuration: IP Address (192.168.0.1), Subnet Mask (255.255.255.0), Default Gateway (192.168.0.254), Default DNS 1 (192.168.0.100), and Default DNS 2 (192.168.0.101). A 'DNS Flush Period' dropdown menu is set to 'Disable'. At the bottom of the form are 'OK' and 'Reset' buttons.

- **Obtain an IP address automatically (DHCP)**

If DHCP is selected, the Network will obtain an IP address automatically with a valid Network DHCP Server. Therefore, manual settings are not required.

This is only to be chosen if your Network environment supports DHCP. It will automatically generate all information.

- **Use following IP address**

You can also enter the Network information manually for IP Address, Subnet Mask, Default Gateway, Default DNS 1 and Default DNS 2.

Please make sure that you have obtained all required values according to your Network environment. Please contact your network administrator and/or internet service provider for more information.

- **DNS Flush Period**

You can set the system to clear current DNS resolution records for all entered URL settings (Reporting, Upload, XMPP...etc.) after a set time period. The system will then resolve the Domain Name again and acquire new IP address for the URL settings. This function is disabled by default.

7.3. UPnP

UPnP is Universal Plug and Play, which opens networking architecture that leverages TCP/IP and the Web technologies to enable seamless proximity networking in addition to control and data transfer among networked devices in the home, office, and public spaces.

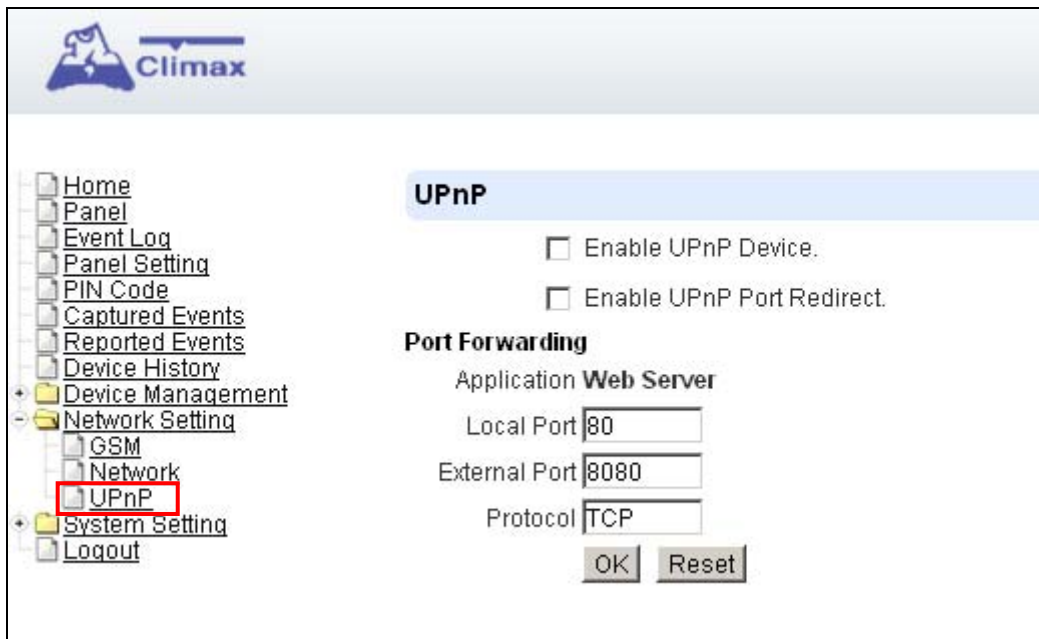

- **Enable UPnP Device:**

When enabled, you will be able to see this device via any UPnP discovery tool

- **Enable UPnP Port Redirect:**

The device will try to find an UPnP-supported router and set up the port to redirect to the router.

- **Port Forwarding:**

1. **Local Port**
2. **External Port**
3. **Protocol**

8. System Settings

8.1. Administrator Setting

It is used to set new Administrator Log-in Name and Password when accessing this web page.

Please note the Caps for your User Name and Password.

Step 1. Enter the preferred **User Name**.

Step 2. Enter the preferred **Password** in the “New Password” field and repeat the same Password in the **Repeat Password** field.

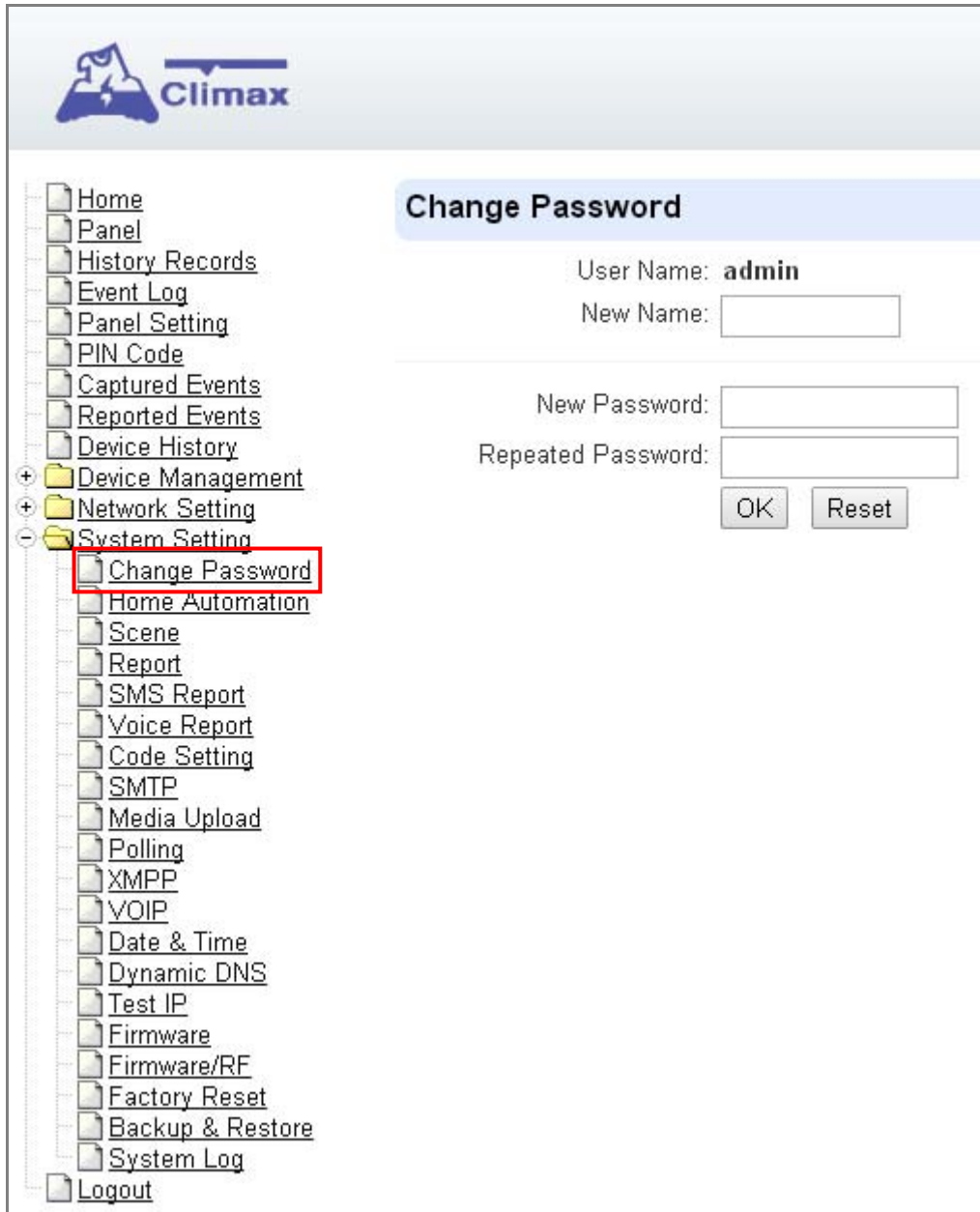

The screenshot displays the Climax web interface. On the left is a navigation tree with the following items: Home, Panel, History Records, Event Log, Panel Setting, PIN Code, Captured Events, Reported Events, Device History, Device Management (expanded), Network Setting (expanded), System Setting (expanded), Change Password (highlighted with a red box), Home Automation, Scene, Report, SMS Report, Voice Report, Code Setting, SMTP, Media Upload, Polling, XMPP, VOIP, Date & Time, Dynamic DNS, Test IP, Firmware, Firmware/RF, Factory Reset, Backup & Restore, System Log, and Logout. On the right, the 'Change Password' form is visible, featuring a header with the Climax logo and the title 'Change Password'. The form contains the following fields and controls: 'User Name: admin', 'New Name: [text input]', 'New Password: [text input]', 'Repeated Password: [text input]', and 'OK' and 'Reset' buttons.

8.2. Home Automation

It is used to set Home Automation rules to control sensors and home appliances. You can set up to 100 rules.

- Step 1.** Click on **Edit**.
- Step 2.** Select an operation area.
- Step 3.** Set a rule condition.
- Step 4.** Set a rule schedule.
- Step 5.** Select the corresponding action rules in the **Execution** field.

Home Automation					
#	Area	Rule Condition	Rule Schedule	Execution	Edit
1		Empty	Always	Empty	Edit
2		Empty	Always	Empty	Edit
3		Empty	Always	Empty	Edit
4		Empty	Always	Empty	Edit
5		Empty	Always	Empty	Edit
6		Empty	Always	Empty	Edit
7		Empty	Always	Empty	Edit
8		Empty	Always	Empty	Edit
9		Empty	Always	Empty	Edit
10		Empty	Always	Empty	Edit
11		Empty	Always	Empty	Edit
12		Empty	Always	Empty	Edit
13		Empty	Always	Empty	Edit
14		Empty	Always	Empty	Edit
15		Empty	Always	Empty	Edit

- **Area**
Select an operation area.
- **Rule Condition**
The rule condition determines under which circumstances the rule should be activated.
 - ☞ **Empty** : When set as **Empty**, the system will follow the schedule time and execution rule to respond accordingly.
 - ☞ **Trigger Alarm** : When set as **Trigger Alarm**, if the specified alarm event (Burglar/Some/Medical/Water/Silent Panic/Panic/Emergency/Fire /CO Alarm) is triggered, the rule will be activated according to rule schedule and execution setting.

Trigger Alarm
Burglar Alarm

- ☞ **Mode Change** : When set as **Mode Change**, when the system enters specified mode, the rule will be activated according to rule schedule and execution setting.

- ☞ **Mode Change and Exit Timer Stopped** : When set as **Mode Change and Exit Timer Stopped**, when the system changes mode to and Exit Delay Timer expires, the rule will be activated according to rule schedule and execution setting.

- ☞ **Mode Start Entry Timer** : When set as **Mode Start Entry Timer**, when the system begins to countdown Entry Delay, the rule will be activated according to rule schedule and execution setting.

- ☞ **Temperature Below** : When set as **Temperature Below**, if the temperature detected by specified temperature sensor drops below set threshold, the rule will be activated according to rule schedule and execution setting.

- ☞ **Temperature Above** : When set as **Temperature Above**, if the temperature detected by specified temperature sensor exceeds set threshold, the rule will be activated according to rule schedule and execution setting.

- ☞ **Temperature Between** : When set as **Temperature Between**, if the temperature detected by specified temperature sensor falls within the range specified, the rule will be activated according to rule schedule and execution setting.

- ☞ **High Power Consumption** : When set as **Power Consumption Above**, if the power output watt from a specific Power Switch exceeds, the rule will be activated according to rule schedule and execution setting.

- ☞ **Humidity Above** : When set as **Humidity Above**, if the humidity reading from specified room sensor rises above the level specified, the rule will be activated according to rule schedule and execution setting.

- ☞ **Humidity Below** : When set as **Humidity Below**, if the humidity reading from specified room sensor falls below the level specified, the rule will be activated according to rule schedule and execution setting.

- ☞ **LUX Between** : When set as **LUX Between**, if the lux reading from specified light sensor falls below the level specified, the rule will be activated according to rule schedule and execution setting.

- **Rule Schedule**

- ☞ **Always** : When set as **Always**, the rule can be activated anytime.

- ☞ **Schedule Once** : When set as **Schedule Once**, the system will follow the rule condition and execute rule according to the exact date and time specified..

- ☞ **Schedule Every Month** : When set as **Schedule Every Month**, the system will follow the rule condition and execute rule according to date and time specified every month.

- ☞ **Schedule Every Week** : When set as **Schedule Every Week**, the system will follow the rule condition and execute rule according to day of the week and time specified every week.

- ☞ **Schedule Every Day** : When set as **Schedule Every Day**, the system will follow the rule condition and execute rule according to time specified every day

- **Execution**

Execution is the actual action performed by Control Panel when both Rule Condition and Rule Schedule requirements are met

- ☞ **Zone Switch Off:** Turn on the Power Switch at specified zone.

☞ **Zone Switch On** : Turn on the Power Switch at specified zone.

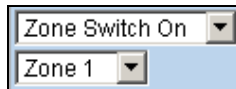

☞ **Zone Switch On For** : Turn on the Power Switch at specified zone for a set duration.

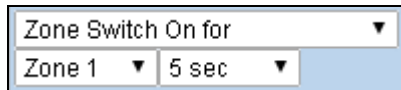

☞ **Zone Switch Level**: Change the power output level for Dimmer at specified zone.



☞ **Zone Switch Toggle** : Toggle on/off the Power Switch at specified zone.

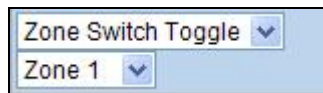

☞ **Group Switch Off** : Turn off all Power Switches assigned to specified group.

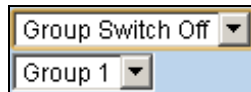

☞ **Group Switch On** : Turn on all Power Switches assigned to specified group.

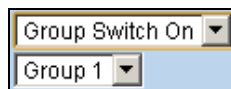

☞ **Group Switch On For** : Turn on all Power Switches assigned to specified group for a set duration.

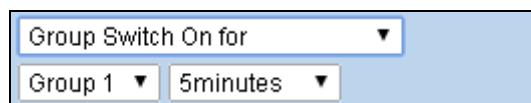

☞ **Mode Change** : The system will change to the mode as you specified.

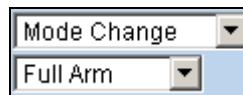

☞ **Request Image** : The PIR Camera in specified zone will take a picture.

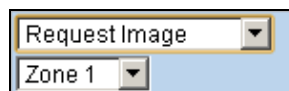

☞ **Request Image (All)** : All PIR Cameras in the system will take a picture.

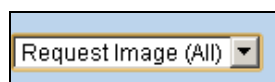

- ☞ **Request Image (No Flash)**: The PIR Camera in specified zone will take a picture without activating its LED flash.

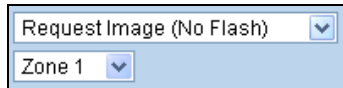

- ☞ **Request Image (All, No Flash)**: All PIR Cameras in the system will take a picture without activating LED Flash.

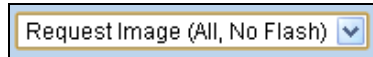

- ☞ **Request Video**: The PIR Video Camera or IP Camera in specified zone will record a video.



- ☞ **Request Video (All)**: All PIR Video Cameras and IP Cameras in the system will record a video.



- ☞ **Setup UPIC**: The UPIC and specified zone will transmit Off/Heat/Cool command to the air conditioner as programmed.

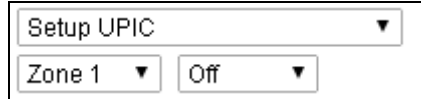

- ☞ **Trigger Alarm**: Choose to activate one of the following alarms: High Temperature Alarm, Low Temperature Alarm, High Power Consumption Alarm, High Humidity Alarm and Low Humidity Alarm

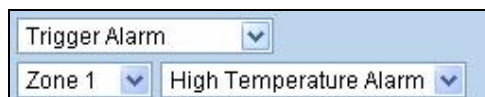

- ☞ **Apply Scene**: the system will execute preprogrammed Scene number. Please refer to **8.3. Scene** for detail.

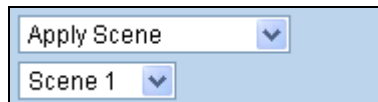

8.3. Scene

The Scene setting allows you to customize a series of actions with your devices, such as Power Switch control, image/video request, mode change and trigger alarm. The programmed scene can be set to activated when a device is triggered. (See 5.1.3. **Edit Devices**), or when a Home Automation Rule is executed. (See 8.2. **Home Automation**) For example, you can set a scene to control multiple lightings, then set your Remote Controller to activate the scene when the button is pressed, or set a Home Automation Rule to activate the scene.

#	Name	#	Area	Execution	
1	Empty	1	1	Empty	Edit Delete
2	Empty	1	1	Empty	Edit Delete
3	Empty	1	1	Empty	Edit Delete
4	Empty	1	1	Empty	Edit Delete

Step 1. Click on **Edit**.

#	Name	#	Area	Execution	
1	<input type="text"/>	1	1 ▼	Empty ▼	Done
		2	1 ▼	Empty ▼	
		3	1 ▼	Empty ▼	
		4	1 ▼	Empty ▼	
		5	1 ▼	Empty ▼	

Step 2. Enter a name for the scene.

Step 3. Select an Area

Step 4. Select an action to be executed when the scene is activated. Refer to the Rule Execution section in 8.2. **Home Automation** for detail.

- Step 5.** Repeat Step 2-3 to setup the execution you wanted. As many as 5 executions can be included in one scene.
- Step 6.** Click **“Done”**.
- Step 7.** Click **“OK”** at bottom of webpage to confirm the new scene setting..

8.4. Reporting

This is used for installer to program/ set all requirements for reporting purposes.

Report							
#	Reporting URL	Level	Group 1	Group 2	Group 3	Group 4	Group 5
1		All events ▼	<input type="radio"/>	<input type="radio"/>	<input type="radio"/>	<input type="radio"/>	<input type="radio"/>
2		All events ▼	<input type="radio"/>	<input type="radio"/>	<input type="radio"/>	<input type="radio"/>	<input type="radio"/>
3		All events ▼	<input type="radio"/>	<input type="radio"/>	<input type="radio"/>	<input type="radio"/>	<input type="radio"/>
4		All events ▼	<input type="radio"/>	<input type="radio"/>	<input type="radio"/>	<input type="radio"/>	<input type="radio"/>
5		All events ▼	<input type="radio"/>	<input type="radio"/>	<input type="radio"/>	<input type="radio"/>	<input type="radio"/>
6		All events ▼	<input type="radio"/>	<input type="radio"/>	<input type="radio"/>	<input type="radio"/>	<input type="radio"/>
7		All events ▼	<input type="radio"/>	<input type="radio"/>	<input type="radio"/>	<input type="radio"/>	<input type="radio"/>
8		All events ▼	<input type="radio"/>	<input type="radio"/>	<input type="radio"/>	<input type="radio"/>	<input type="radio"/>
9		All events ▼	<input type="radio"/>	<input type="radio"/>	<input type="radio"/>	<input type="radio"/>	<input type="radio"/>
10		All events ▼	<input type="radio"/>	<input type="radio"/>	<input type="radio"/>	<input type="radio"/>	<input type="radio"/>
11		All events ▼	<input type="radio"/>	<input type="radio"/>	<input type="radio"/>	<input type="radio"/>	<input type="radio"/>
12		All events ▼	<input type="radio"/>	<input type="radio"/>	<input type="radio"/>	<input type="radio"/>	<input type="radio"/>
13		All events ▼	<input type="radio"/>	<input type="radio"/>	<input type="radio"/>	<input type="radio"/>	<input type="radio"/>
14		All events ▼	<input type="radio"/>	<input type="radio"/>	<input type="radio"/>	<input type="radio"/>	<input type="radio"/>
15		All events ▼	<input type="radio"/>	<input type="radio"/>	<input type="radio"/>	<input type="radio"/>	<input type="radio"/>
16		All events ▼	<input type="radio"/>	<input type="radio"/>	<input type="radio"/>	<input type="radio"/>	<input type="radio"/>
17		All events ▼	<input type="radio"/>	<input type="radio"/>	<input type="radio"/>	<input type="radio"/>	<input type="radio"/>
18		All events ▼	<input type="radio"/>	<input type="radio"/>	<input type="radio"/>	<input type="radio"/>	<input type="radio"/>
19		All events ▼	<input type="radio"/>	<input type="radio"/>	<input type="radio"/>	<input type="radio"/>	<input type="radio"/>
20		All events ▼	<input type="radio"/>	<input type="radio"/>	<input type="radio"/>	<input type="radio"/>	<input type="radio"/>
			Essential	Essential ▼	Essential ▼	Essential ▼	Essential ▼
			5 Retry ▼	5 Retry ▼	5 Retry ▼	5 Retry ▼	5 Retry ▼

- **Reporting URL**

This is used for installer to program/ set all requirements for reporting purposes.

☞ Report via IP (Ethernet or GPRS) in CID format:

ip://Account Number@server ip:port/CID

☞ Report via IP (Ethernet or GPRS) in SIA format:

ip://Account Number @server ip:port/SIA

☞ Report via IP (Ethernet or GPRS) in CSV format:

ip://Account Number @server ip:port/CSV

☞ Report via IP (Ethernet or GPRS) in CSV format including user name and password:

ip://Account Number @server ip:port/CSV/User/Pasword

☞ Report via GSM CID:

gsm://Account Number@telephone number

<NOTE>

☞ Account number is 4 ~ 6 digits.

☞ Report via email (Requires SMTP setting)

mailto: user@example.com

- **Level**

Select a reporting condition:

All events: The system will report all events to this destination.

Alarm events: The system will only report alarm event to this destination.

Status events: The system will only report status event(non-alarm events) to this destination.

- **Group**

Select a group for your report destination The system will make report according to the following principle:

- ☞ Group with higher priority will be reported first: Ex: Group 1 → Group 2 → Group 3....
- ☞ If reporting to the first destination in a group fails, the system will move on to the next report destination in the group.
- ☞ If reporting to one of the report destinations in a group is successful, the system will consider reporting to this group successful and stop reporting to rest of the destinations in the group. It will then move on to report to the next group.
- ☞ If reporting to all destinations in a group fails, the system will retry report to group according to retry times set below. If reporting is still unsuccessful after retries, the system will move on to report the the next group according to Essential/Optional setting below.
- ☞ After completing a round of reporting (From Group 1 → Group 2 →Group5), If there is any group set as Essential which has not received report successfully, the system will restart the reporting cycle to retry reporting until every group set as Essential is reported successfully.

- **Essential/Optional**

Essential: the system will report to all groups set as **Essential**. The system will never give up trying to report to any group set as Essential until at least one of the destinations in every Essential group successfully receives the report. Group 1 is always set as **Essential** and cannot be changed.

Optional: The system will only report to group set as **Optional** when reporting to its previous group fails. For example: if Group 3 is set is optional, the Control Panel will only report to Group 3 if reporting to Group 2 fails.

- **1 Retry/ 3 Retry/ 5 Retry/ 10 Retry/ 99 Retry:**

If reporting to all destinations in a group fails, the system will retry reporting to the group according to the retries times set here.

<NOTE>

- ☞ When the panel is registered into Climax's Home Portal Server, URL1 will be filled in with Home Portal Server report information. Do not change the information once registration is complete or reporting to Home Portal Server may encounter error.
- ☞ After registering the panel in Home Portal Server, if you wish to set more reporting destination, the new report destination should be set to different group than URL1 otherwise it may not be able to receive report successfully.

8.5. SMS Report (HPGWL-2/3/5 and HPGW-G2/3/5 only)

This is used for setting SMS reporting .

The screenshot shows the Climax web interface. The left sidebar contains a navigation menu with the following items: Home, Panel, History Records, Event Log, Panel Setting, PIN Code, Captured Events, Reported Events, Device History, Device Management, Network Setting, System Setting (expanded), Change Password, Home Automation, Scene, Report, **SMS Report** (highlighted in red), Voice Report, Code Setting, SMTP, Media Upload, Polling, XMPP, VOIP, Date & Time, Dynamic DNS, Test IP, Firmware, Firmware/RF, Factory Reset, Backup & Restore, System Log, and Logout.

The main content area is titled 'SMS Report' and contains a table with the following structure:

	Reporting URL	Level
1.	<input type="text"/>	All events ▼
2.	<input type="text"/>	All events ▼
3.	<input type="text"/>	All events ▼
4.	<input type="text"/>	All events ▼
5.	<input type="text"/>	All events ▼

Below the table, there are two notes:

Note: 1. Report via SMS in CID format, ex: sms://ACCT@telephone
2. Report via SMS text, ex: sms://ACCT@telephone/TEXT

At the bottom of the configuration area, there are two buttons: 'OK' and 'Reset'.

©2014 Climax Tech. Co., Ltd.

- **Reporting URL**

Set the SMS report destination according to following format:

sms://Account Number@telephone number

- **Level**

Select the event type that will be reported to this reporting destination:

All events: The system will report all events to this destination.

Alarm events: The system will only report alarm event to this destination.

Status events: The system will only report status event(non-alarm events) to this destination.

<NOTE>

- ☞ If all functions are enabled, then only ONE function will be carried out. Priority sequence is IP> Voice Telephone > CID reporting over GSM> Follow On> SMS reporting > Callback Timer.

8.6. Voice Report (HPGWL-3 / HPGW-G1D / HPGW-G3 Only)

Panel models with DECT device capability are able to make voice call during alarm reporting and establish two-way voice communication with call recipient. Each two-way voice session lasts 3 minutes. At the last 30 & 10 secs of two way conversation, the DECT device will emit 1 short beep to alert the call recipient.

The panel will make voice report after the first successful alarm reporting. At least one report destination must be programmed to use voice reporting function.

Warning: Voice reporting is not available when AC power failure is detected.

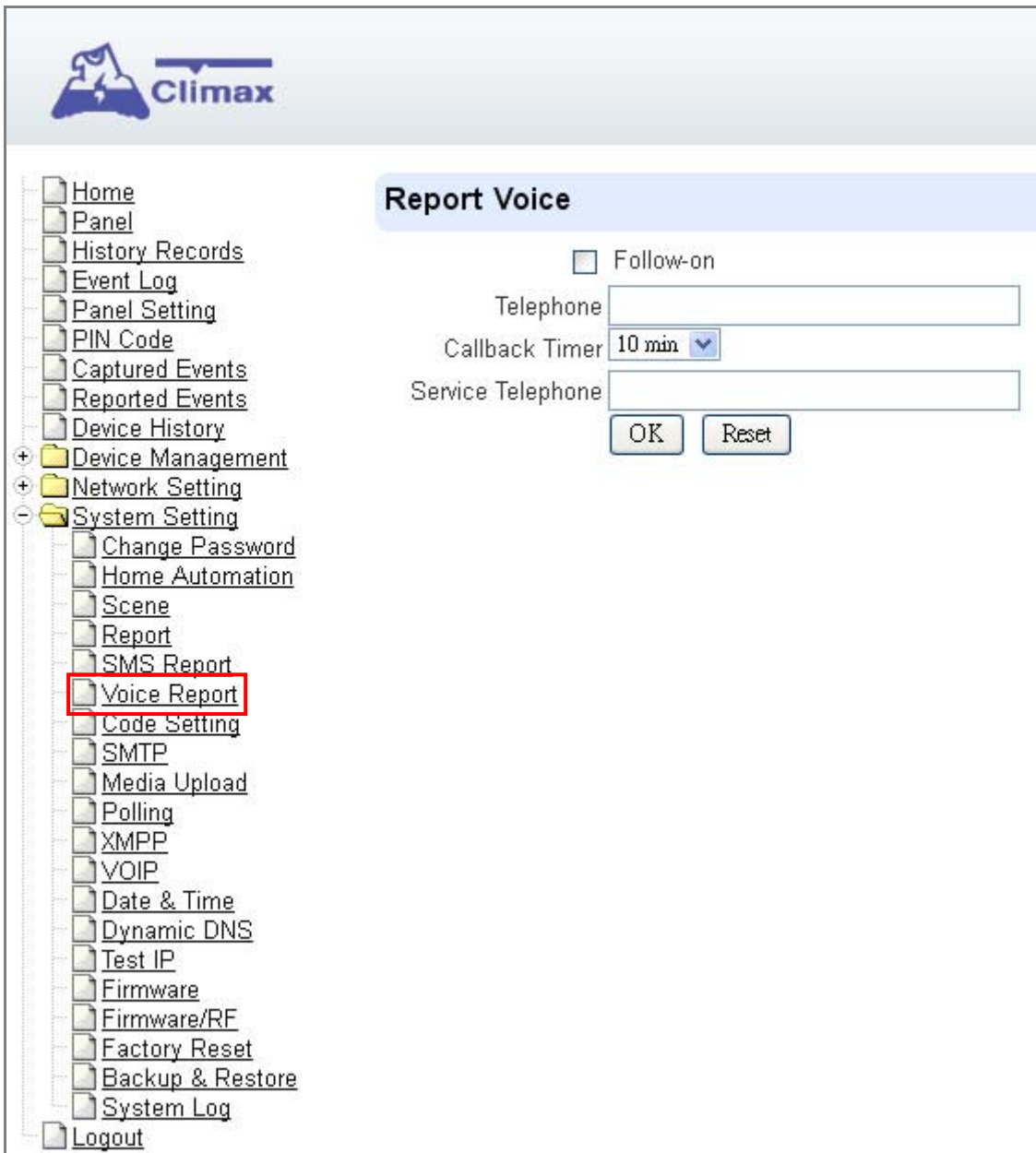

The screenshot shows the Climax control panel web interface. On the left is a navigation tree with the following items: Home, Panel, History Records, Event Log, Panel Setting, PIN Code, Captured Events, Reported Events, Device History, Device Management, Network Setting, System Setting (expanded), Change Password, Home Automation, Scene, Report, SMS Report, Voice Report (highlighted with a red box), Code Setting, SMTP, Media Upload, Polling, XMPP, VOIP, Date & Time, Dynamic DNS, Test IP, Firmware, Firmware/RF, Factory Reset, Backup & Restore, System Log, and Logout. The main content area is titled 'Report Voice' and contains the following settings:

- Follow-on
- Telephone: [text input field]
- Callback Timer: 10 min [dropdown menu]
- Service Telephone: [text input field]
- OK [button]
- Reset [button]

- **Follow-on**

Check the box to enable the Follow-on function.

If enabled, the Control Panel will open two-way communication after the first GSM CID report

If not enabled, the Control Panel will dial the telephone number set below after the first successful report.

- **Telephone**

Enter the telephone number in the field, if Follow-on is enabled, leave the telephone number blank.

- **Callback Timer**

If not disabled (set to 5 or 10 minutes). After an alarm has been reported, the panel will enter a waiting period for callback. Incoming call during this period will be answered automatically to open two-way communication with DECT devices. The Callback time will end after set waiting period has expired or after the incoming call has ended.

- **Service Telephone**

The service telephone number can only be dialed using VST-809 for non-emergency service call.

<NOTE>

- ☞ VOIP setting must be programmed first before the Control Panel can make report via VOIP. Please refer to **8.12. VOIP** for more information.

8.7. Code Settings

The Duress Code, Master Code & Temporary Code adds the flexibility of different security level for operation in **Code Settings** menu.

Step 1. Key in your preferred 4 digit **Installer Code**, **Duress Code**, **Master Code**, and/or **Temporary Code**.

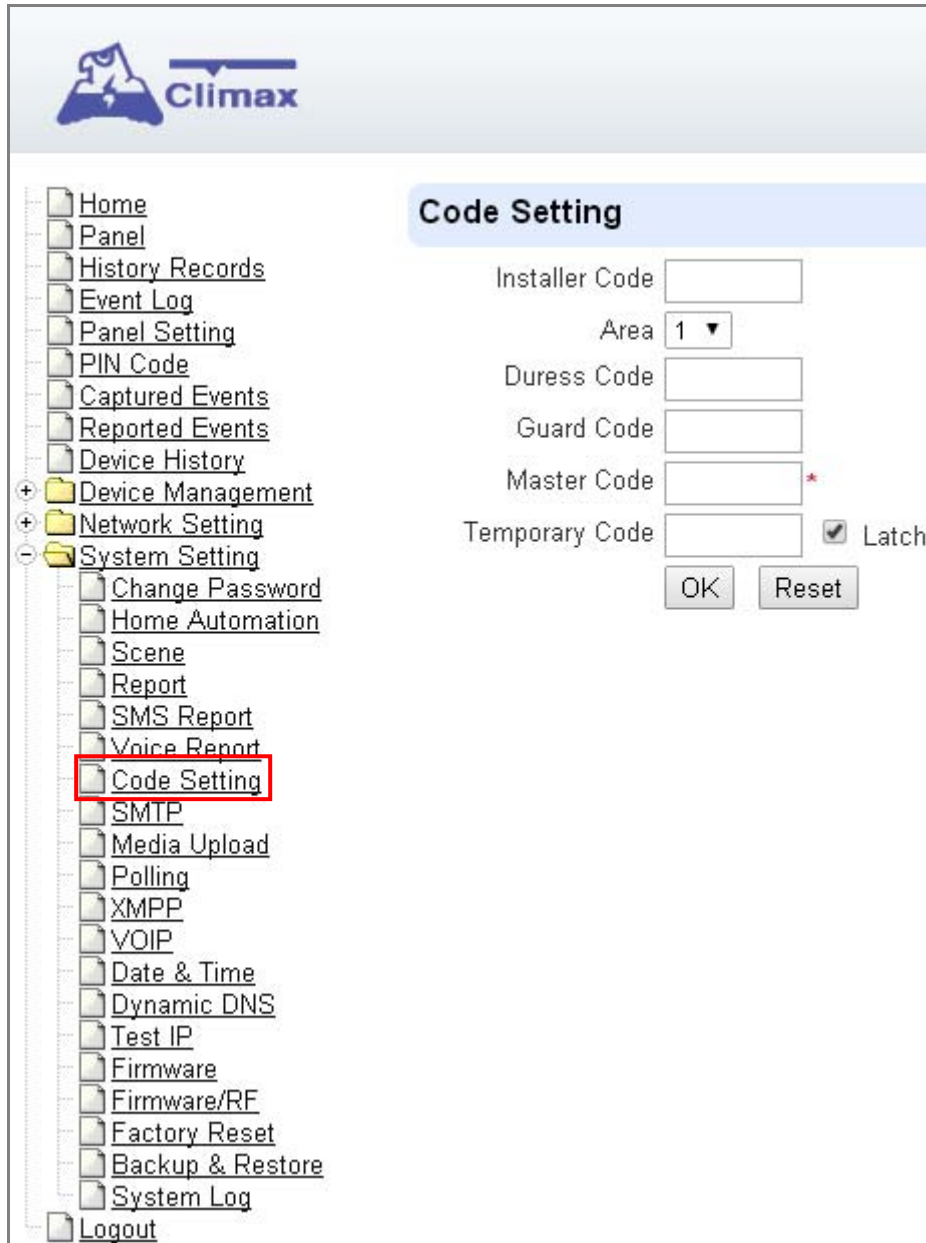

The screenshot displays the Climax web interface. On the left is a navigation tree with 'Code Setting' highlighted in a red box. The main area is titled 'Code Setting' and contains the following fields:

- Installer Code:
- Area: ▼
- Duress Code:
- Guard Code:
- Master Code: *
- Temporary Code: Latch

At the bottom of the form are 'OK' and 'Reset' buttons.

Step 2. You can also choose to have Latch Option On / Off for Temporary Code by tick the Latch Option box and press **OK** to confirm the settings.

- **Installer Code**

The Installer Code is used for SMS Remote Programming, when sending a remote programming message, the user needs to enter Installer Code in the message to be able to program the system. The default Installer code is: **7982**.

- **Area**

Each Area has different Duress Code, Master Code, and Temporary Code. Select the Area to program the code setting in this area.

- **Duress Code**

The Duress Code is designed for transmitting a secret & silence alarm.

When Duress Code is used for accessing the system, the Control Panel will report a secret alarm message without sounding the siren to the Central Monitoring Station to indicate of a **Duress Situation in Progress**.

The Duress Code consists of 4 digits and is not activated as default by the factory.

- **Guard Code**

The Guard Code is designed for security patrol personnel to arm/disarm the system. It can be set the same as a User PIN Code.

The Guard Code consists of 4 digits and is not activated as default by the factory.

- **Master Code**

This function is currently disabled.

- **Temporary Code**

Temporary Code is also used to arm/disarm the system, but it is for a temporary user. The temporary Code is **ONLY** valid for one-access per arming and disarming. Afterwards, the Temporary Code will be automatically erased and needs to be reset for a new Temporary user.

The Temporary Code consists of 4 digits and is not activated as default by the factory.

- **Latch Option**

This is to program the Latch Key Reporting feature for Temporary Code. Please click the box to select the options.

Latch → **Latch Report ON** = Whenever the system is armed, home/ day home/ night home armed or disarmed, the Panel will transmitt Contact ID code / SMS message / GPRS reporting (according to pre-setting) to notify the Central Monitoring Station.

Latch → **Latch Reprot OFF** = Whenever the system is armed, home/ day home/ night home armed or disarmed, the Panel will NOT transmit reporting(s) to notify the Central Monitoring Station.

- **Delete**

Except Master Code which can't be disabled in any way, Temporary and Duress Code can be disabled by cleaning the code box and leaving the box as blank.

8.8. SMTP Setting

Program the mail server related settings. The email account you set here would be used to send report for events or picture and video clip captured by PIR Camera and PIR Video Camera.

The screenshot shows the Climax web interface. On the left is a navigation tree with the following items: Home, Panel, History Records, Event Log, Panel Setting, PIN Code, Captured Events, Reported Events, Device History, Device Management, Network Setting, System Setting (expanded), Change Password, Home Automation, Scene, Report, SMS Report, Voice Report, Code Setting, SMTP (highlighted with a red box), Media Upload, Polling, XMPP, VOIP, Date & Time, Dynamic DNS, Test IP, Firmware, Firmware/RF, Factory Reset, Backup & Restore, System Log, and Logout. The main content area is titled 'SMTP Setting' and contains the following fields and controls:

- Server:
- Port:
- User:
- Password:
- From:
- Using TLS/SSL encrypted channels (Secure SMTP)
- OK Reset

Below this is a section titled 'Test E-Mail' with the following field and controls:

- Receiver:
- OK Reset

Step 1. Enter the following settings:

- **Server:** set the mail server (max. 60 digits/alphabets).
- **Port:** set the port number (max. 5 digits/alphabets).
- **User:** set the mail account name (max. 30 digits/alphabets).
- **Password:** set the password corresponding to the mail account name (max. 30 digits/alphabets).
- **From:** set the email address according to your mail sever and account name. If your mail server supports other email address, you can enter the email address here. (max. 30 digits/alphabets).
- **Using TLS/SSL encrypted channels (Secure SMTP):** If your mail server uses TLS or

SSL encryption method for secure transfer, please click the box to enable the setting

Step 2. Click **OK** to confirm the setting.

8.9. Media Upload

The system can deliver captured images and video clips captured by PIR Cameras and PIR Video Camera to cell phone, email or ftp.

The screenshot shows the Climax web interface. On the left is a navigation tree with 'Media Upload' selected. The main area is titled 'Media Upload' and contains the following fields and options:

- URL 1:
- URL 2:
- URL 3:
- URL 4:
- URL 5:
- Prefix:
- Delete events after uploaded.

Note:

1. Upload via IP (Ethernet or GPRS) in FTP protocol, ex: ftp://user:password@server/path
2. Upload via IP (Ethernet or GPRS) in HTTP protocol, ex: http://server/path
3. Mail via IP (Ethernet or GPRS), ex: mailto: user@server
4. Send MMS e-mail via GPRS, ex: mms: user@mail.server
5. Send MMS via GPRS, ex: mms: telephone

Buttons: OK, Reset

©2014 Climax Tech. Co., Ltd.

- **FTP:** <ftp://user.password@server/path>
- **HTTP:** <http://ip:port/path>
- **Email:** <mailto:user@server> (transmitting an alarm image over Ethernet)
- **MMS via Telephone:** mms: telephone number
- **MMS via GPRS:** mms: [user@mail.server](mms:user@mail.server) (transmitting an alarm image over MMS)

<NOTE>

- ☞ If “**Deleted events after uploaded**” is checked, the system will automatically clear all captured images which are displayed in the Captured Events menu after it successfully sends out those captured images to preset reporting destinations.

8.10. Polling

The polling function enables the Control Panel to query the destination you set (URL1 or URL2) in turn as to whether it has any data to transmit.

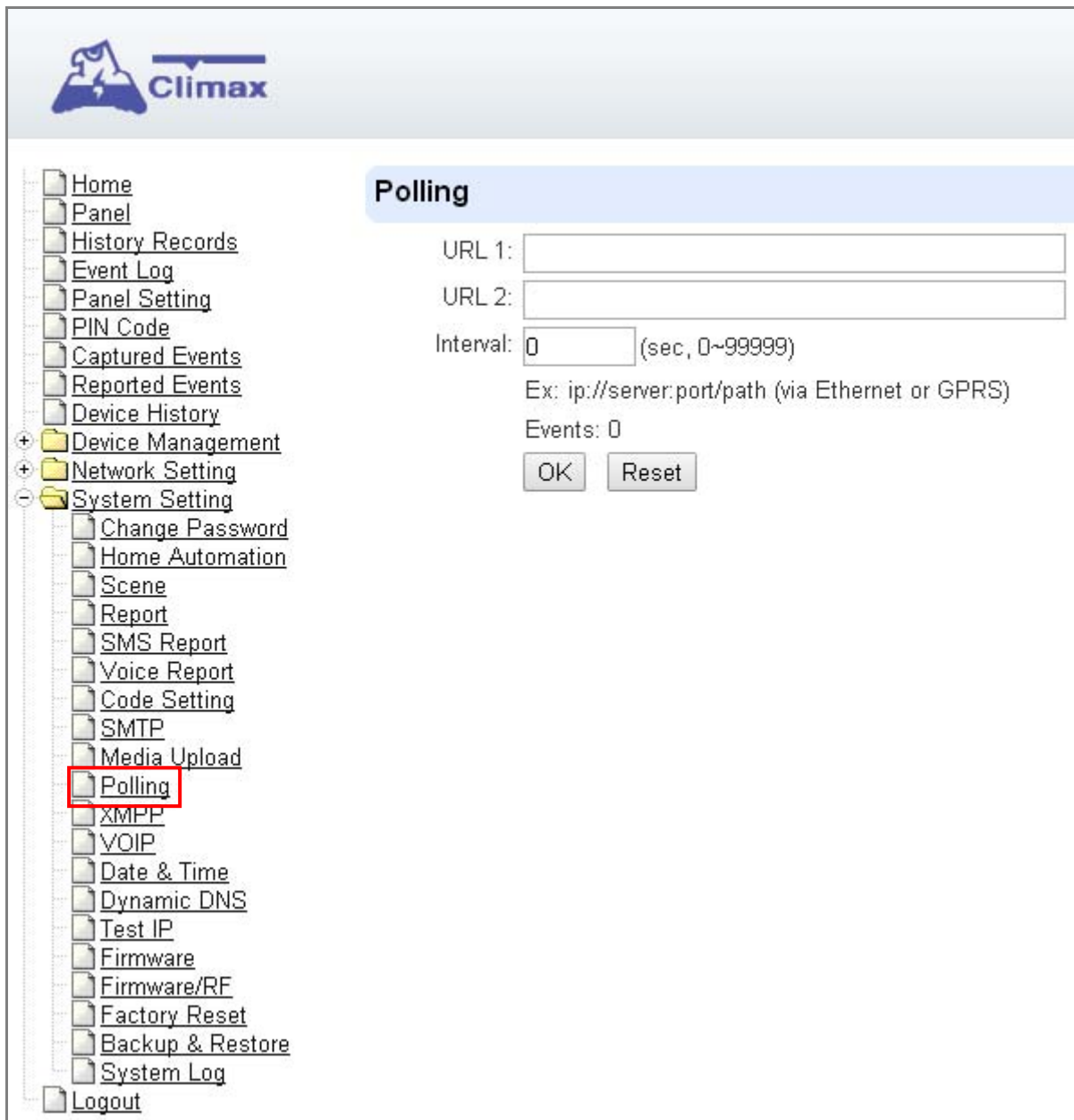

The screenshot shows the Climax Control Panel interface. On the left is a navigation tree with the following items: Home, Panel, History Records, Event Log, Panel Setting, PIN Code, Captured Events, Reported Events, Device History, Device Management, Network Setting, System Setting (expanded), Change Password, Home Automation, Scene, Report, SMS Report, Voice Report, Code Setting, SMTP, Media Upload, Polling (highlighted with a red box), XMPP, VOIP, Date & Time, Dynamic DNS, Test IP, Firmware, Firmware/RF, Factory Reset, Backup & Restore, System Log, and Logout. The main content area is titled "Polling" and contains the following fields and controls:

- URL 1:
- URL 2:
- Interval: (sec, 0~99999)
- Ex: ip://server:port/path (via Ethernet or GPRS)
- Events:
- OK
- Reset

- **URL/URL2:** ip://server:port/path
- **Interval :** interval time of polling

8.11. XMPP

XMPP setting enables the Control Panel to query the set destination. This setting is required for the Control Panel to connect to Climax's Home Portal Server for remote control. If the panel is disconnected from the server, it will retry connection every 3 minutes.

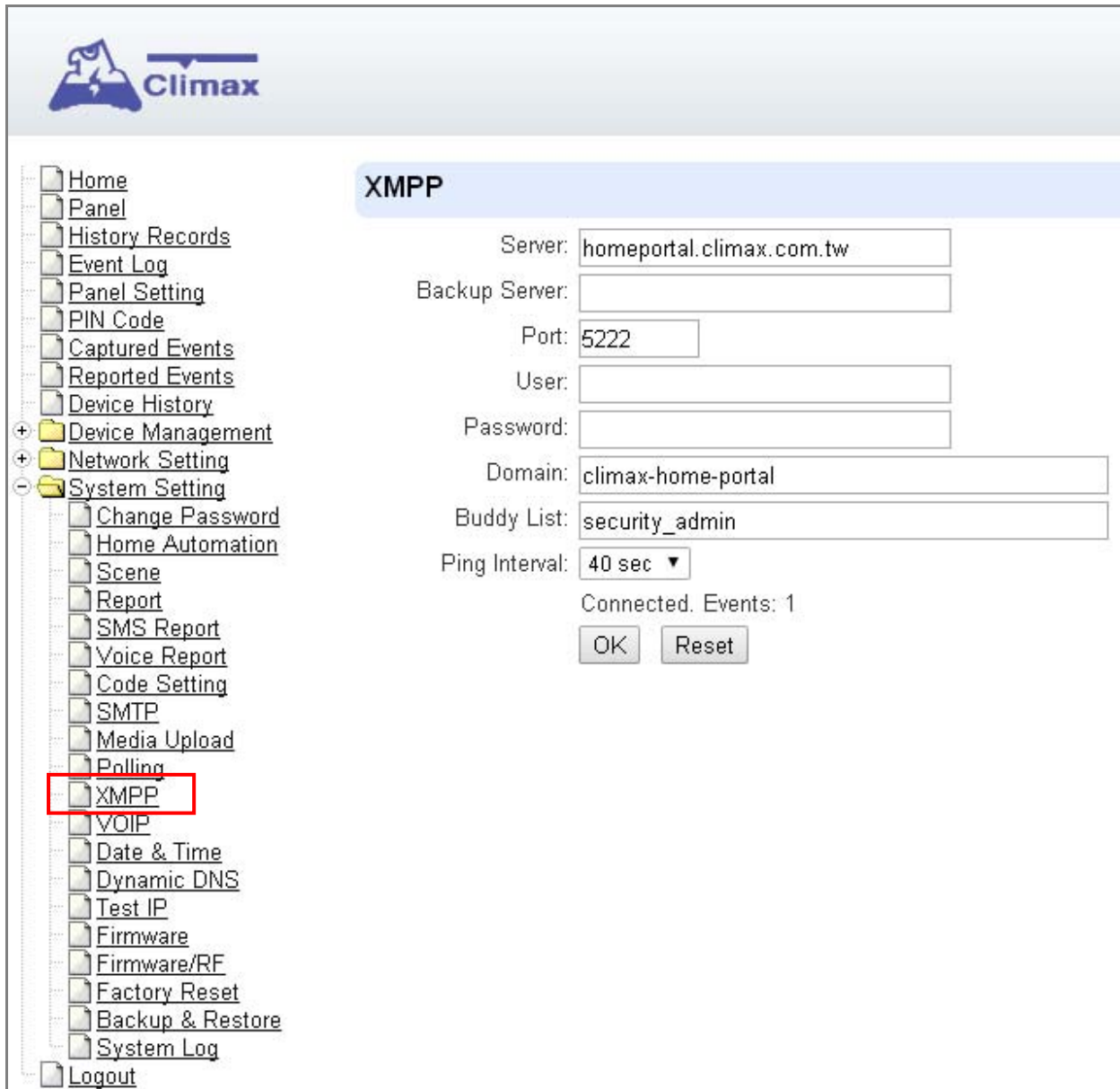

The screenshot displays the Climax control panel interface. On the left, a navigation tree lists various settings, with 'XMPP' highlighted in a red box. The main content area is titled 'XMPP' and contains the following configuration fields:

- Server: homeportal.climax.com.tw
- Backup Server: (empty)
- Port: 5222
- User: (empty)
- Password: (empty)
- Domain: climax-home-portal
- Buddy List: security_admin
- Ping Interval: 40 sec (dropdown menu)
- Connected. Events: 1

At the bottom of the configuration area, there are two buttons: 'OK' and 'Reset'.

- **Server:** server address
- **Port:** server's port number
- **User:** authorized user account name
- **Password:** authorized user password
- **Domain:** domain address
- **Buddy List:** contact destination
- **Ping Interval:** server connection test interval

8.12. VOIP (HPGW-G1D & HPGW-G3 Only)

Program your VOIP server setting with this page. The VOIP setting must be completed before you can use Voice Report function via VOIP.

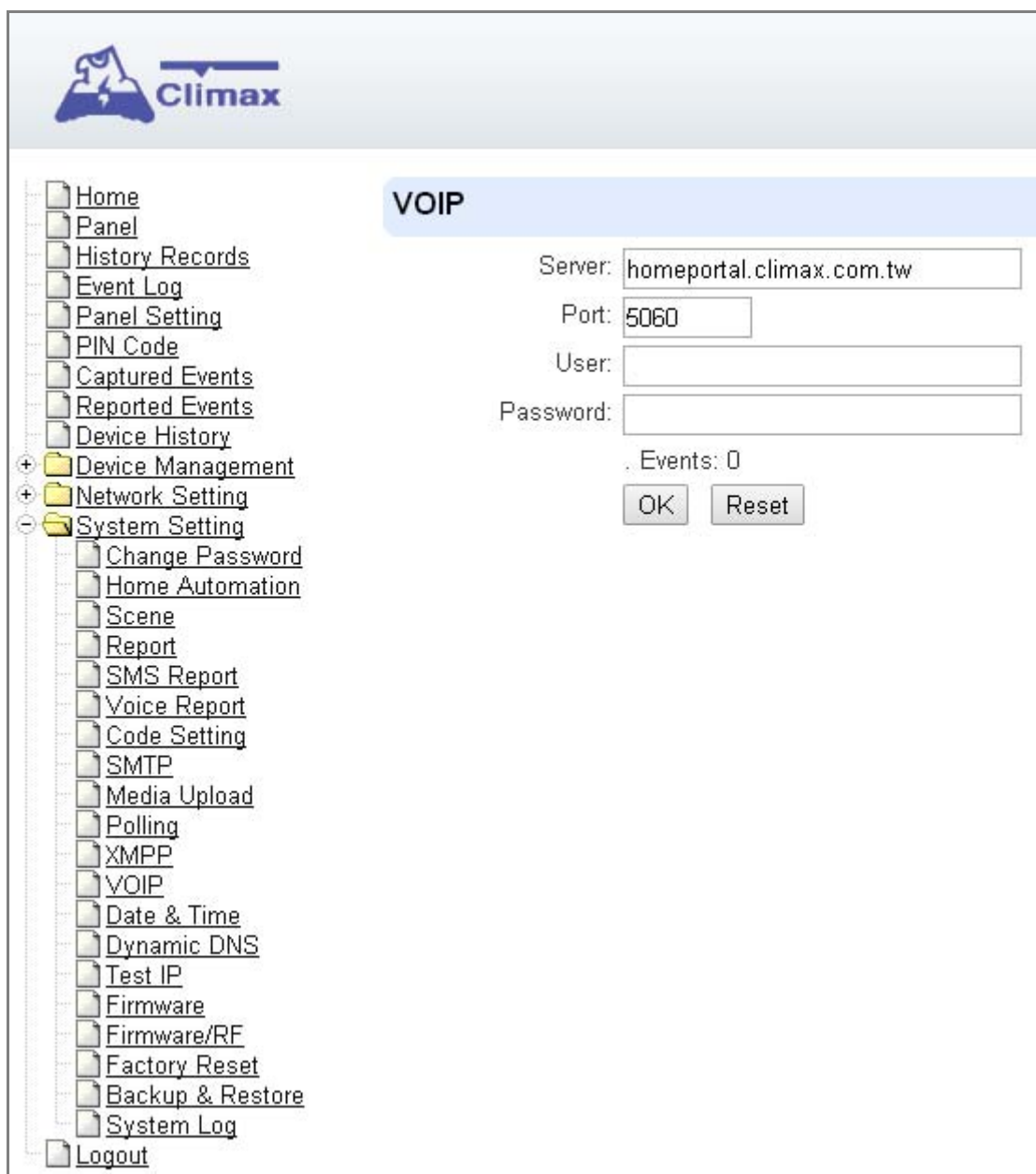

The screenshot displays the Climax web interface. On the left is a navigation tree with the following items: Home, Panel, History Records, Event Log, Panel Setting, PIN Code, Captured Events, Reported Events, Device History, Device Management (expanded), Network Setting (expanded), System Setting (expanded), Change Password, Home Automation, Scene, Report, SMS Report, Voice Report, Code Setting, SMTP, Media Upload, Polling, XMPP, VOIP, Date & Time, Dynamic DNS, Test IP, Firmware, Firmware/RF, Factory Reset, Backup & Restore, System Log, and Logout. The 'VOIP' section is active, showing a 'Server' field with 'homeportal.climax.com.tw', a 'Port' field with '5060', and empty 'User' and 'Password' fields. Below the fields, it shows 'Events: 0' and 'OK' and 'Reset' buttons.

- **Server:** Your VOIP server URL, factory default is set to Climax' Home Portal Server. If you use your own server, a SIP VOIP server is required. We recommend using an **Asterisk** server.
- **User:** Enter your username in the VOIP server
- **Password:** Enter the password.

8.13. Date & Time

Program the current **Date & Time** and set automatic synchronization with internet time server.

The screenshot shows the Climax web interface. On the left is a navigation menu with the following items: Home, Panel, History Records, Event Log, Panel Setting, PIN Code, Captured Events, Reported Events, Device History, Device Management, Network Setting, System Setting (highlighted), Change Password, Home Automation, Scene, Report, SMS Report, Voice Report, Code Setting, SMTP, Media Upload, Polling, XMPP, VOIP, Date & Time (highlighted with a red box), Dynamic DNS, Test IP, Firmware, Firmware/RF, Factory Reset, Backup & Restore, System Log, and Logout. The main content area has three sections: **Date & Time** with fields for Date (2014/05/08) and Time (11:43), **Time Zone** with a dropdown menu set to (GMT+00:00) Greenwich Mean Time: Dublin, Edinburgh, Lisbon, London, and **Internet Time** with a checkbox for automatic synchronization and a dropdown menu for the server set to pool.ntp.org. The footer contains the copyright notice ©2014 Climax Tech. Co., Ltd.

- **Date & Time:** set current month, date and time.
- **Time Zone:** choose your time zone, and then the system will calculate the daylight saving time automatically (if necessary).
- **Internet Time:** the system will automatically synchronize with an internet time server. Tick the check box to enable this function. Available options: pool.ntp.gov, time.nist.gov and tick.usno.navy.mil.

8.14. Dynamic DNS

This page is used to provide you the Control Panel's current public IP address.

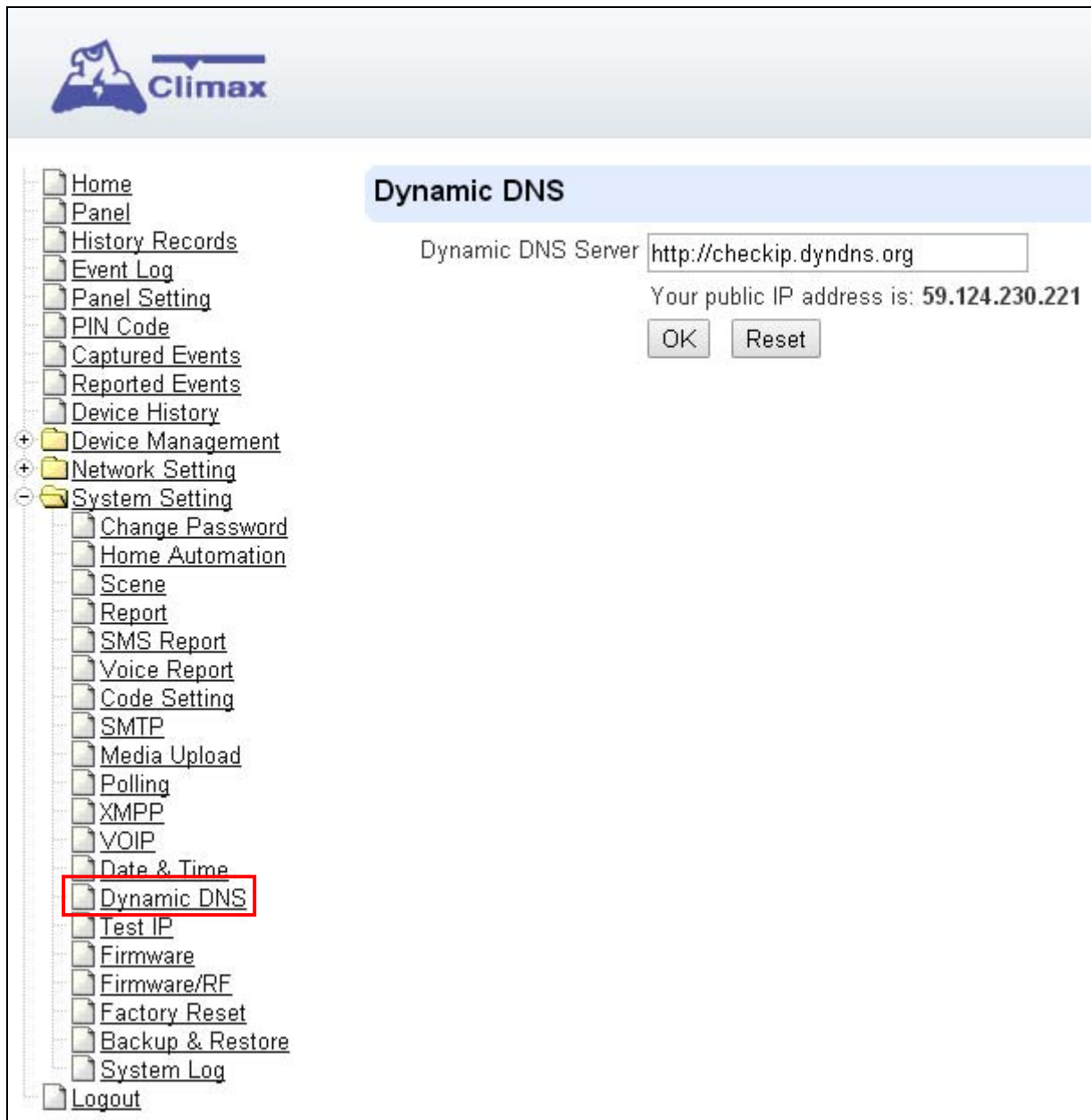

The screenshot shows the Climax Control Panel interface. On the left is a navigation menu with items like Home, Panel, History Records, Event Log, Panel Setting, PIN Code, Captured Events, Reported Events, Device History, Device Management, Network Setting, System Setting, Change Password, Home Automation, Scene, Report, SMS Report, Voice Report, Code Setting, SMTP, Media Upload, Polling, XMPP, VOIP, Date & Time, Dynamic DNS (highlighted with a red box), Test IP, Firmware, Firmware/RF, Factory Reset, Backup & Restore, System Log, and Logout. The main content area is titled "Dynamic DNS" and contains a text input field for the "Dynamic DNS Server" with the value "http://checkip.dyndns.org". Below this, it displays "Your public IP address is: 59.124.230.221" and two buttons labeled "OK" and "Reset".

- **Dynamic DNS Server:** <http://checkip.dyndns.org>

8.15. Test IP

This is for you to test the Control Panel internet connection.

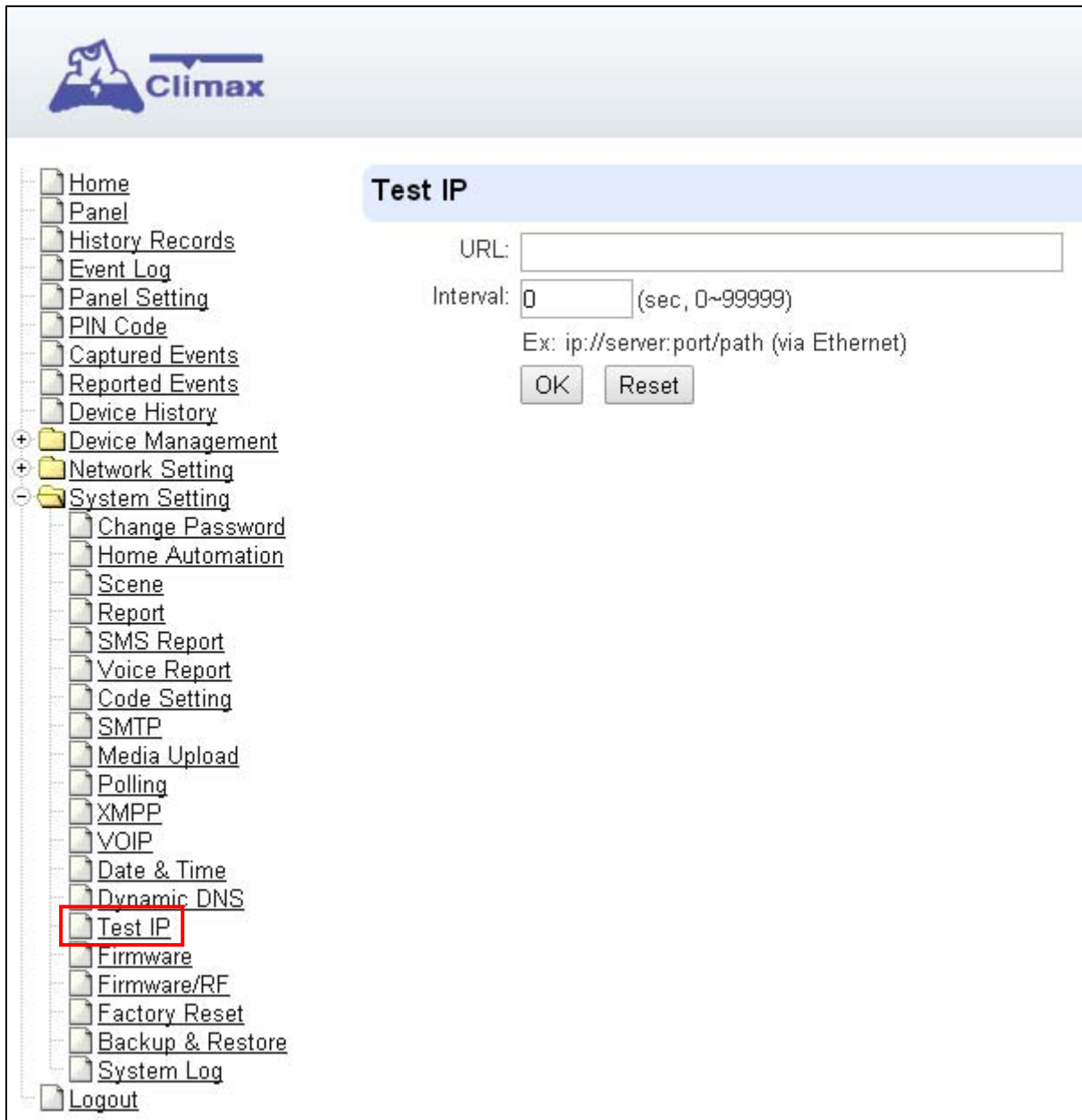

The screenshot shows the Climax Control Panel interface. On the left is a navigation tree with the following items: Home, Panel, History Records, Event Log, Panel Setting, PIN Code, Captured Events, Reported Events, Device History, Device Management (expanded), Network Setting (expanded), System Setting (expanded), Change Password, Home Automation, Scene, Report, SMS Report, Voice Report, Code Setting, SMTP, Media Upload, Polling, XMPP, VOIP, Date & Time, Dynamic DNS, Test IP (highlighted with a red box), Firmware, Firmware/RF, Factory Reset, Backup & Restore, System Log, and Logout. The main content area is titled "Test IP" and contains the following fields and buttons:

- URL:
- Interval: (sec, 0~99999)
- Ex: ip://server:port/path (via Ethernet)
- OK
- Reset

Step 1. Enter the URL destination you want to test connection to.

Step 2. Enter the test interval.

Step 3. Click "OK"

You can check the test connect result in **System Log**.

8.16. Firmware Upgrade

You can update the firmware via this web page.

Step 1. Click on “**Browse**” and locate the latest firmware file (“**unzipped image.bin**” file) in your PC.

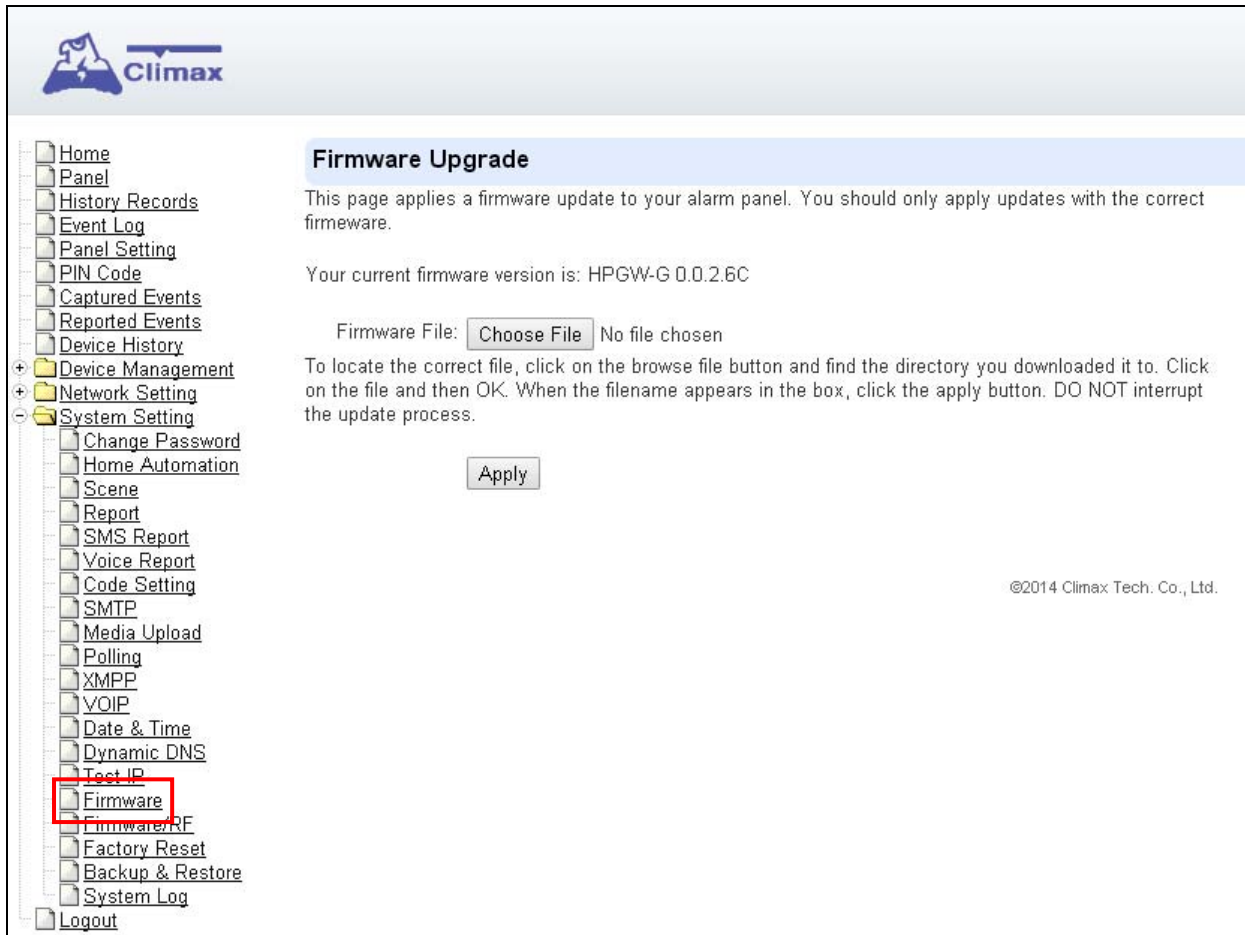

The screenshot shows the Climax web interface. On the left is a navigation menu with items like Home, Panel, History Records, Event Log, Panel Setting, PIN Code, Captured Events, Reported Events, Device History, Device Management, Network Setting, System Setting, Change Password, Home Automation, Scene, Report, SMS Report, Voice Report, Code Setting, SMTP, Media Upload, Polling, XMPP, VOIP, Date & Time, Dynamic DNS, Test IP, **Firmware** (highlighted with a red box), Firmware/RF, Factory Reset, Backup & Restore, System Log, and Logout. The main content area is titled 'Firmware Upgrade' and contains the following text: 'This page applies a firmware update to your alarm panel. You should only apply updates with the correct firmware.' Below this, it states 'Your current firmware version is: HPGW-G 0.0.2.6C'. There is a 'Firmware File:' label followed by a 'Choose File' button and the text 'No file chosen'. Below that is an instruction: 'To locate the correct file, click on the browse file button and find the directory you downloaded it to. Click on the file and then OK. When the filename appears in the box, click the apply button. DO NOT interrupt the update process.' At the bottom of the main content area is an 'Apply' button. In the bottom right corner of the page, there is a copyright notice: '©2014 Climax Tech. Co., Ltd.'

Step 2. Press “**Apply**” to upload the latest firmware to Control Panel

Step 3. Wait for 1 min and do NOT power off during this time.

Step 4. Once Firmware upgrading is complete, the Control Panel will reboot automatically

8.17. RF Firmware Upgrade

You can update the Control Panel's RF firmware via this web page.

Step 1. Click on “**Browse**” and locate the latest firmware file (“**unzipped image.bin**” file) in your PC.

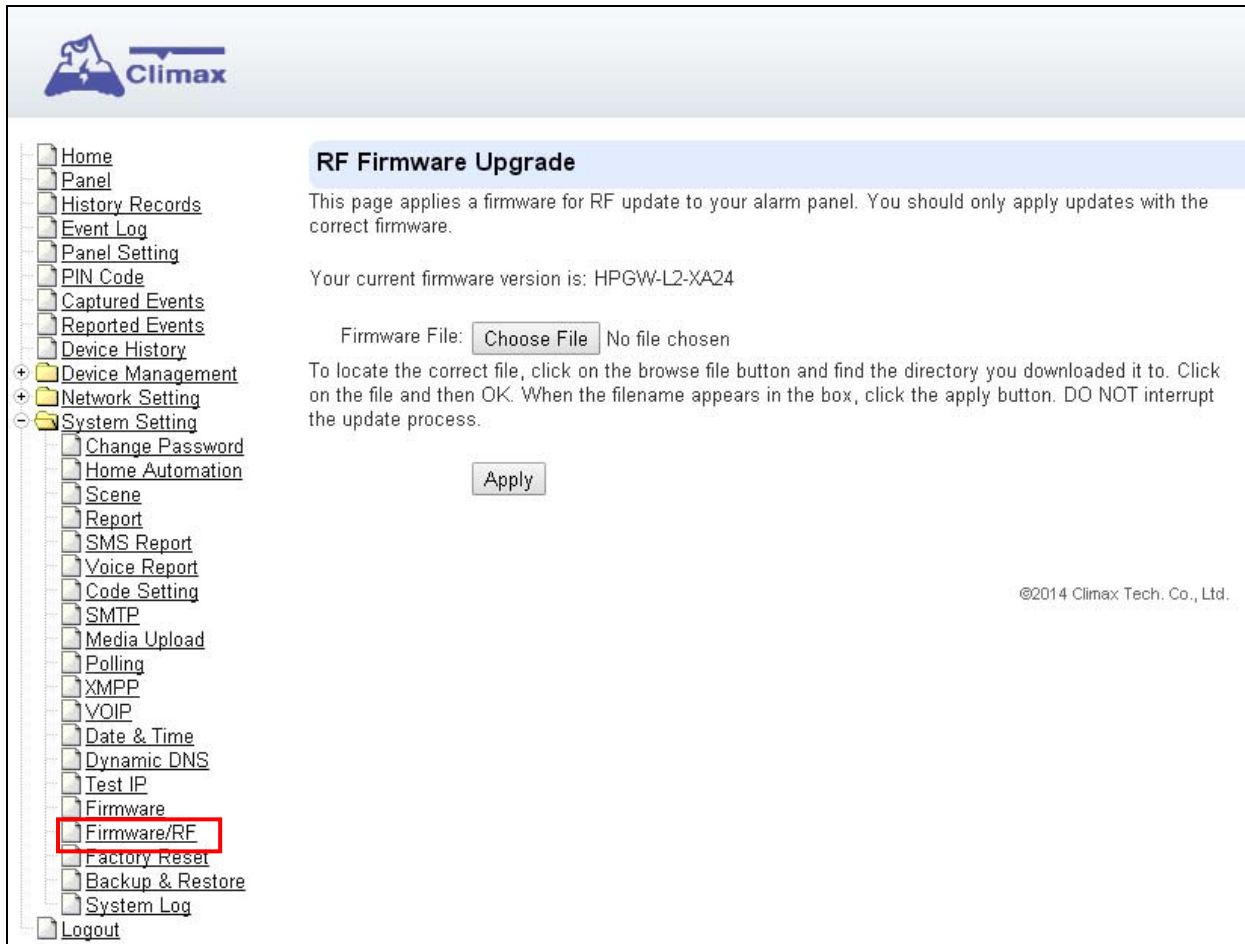

The screenshot shows the Climax web interface. On the left is a navigation menu with items like Home, Panel, History Records, Event Log, Panel Setting, PIN Code, Captured Events, Reported Events, Device History, Device Management, Network Setting, System Setting, Change Password, Home Automation, Scene, Report, SMS Report, Voice Report, Code Setting, SMTP, Media Upload, Polling, XMPP, VOIP, Date & Time, Dynamic DNS, Test IP, Firmware, **Firmware/RF** (highlighted with a red box), Factory Reset, Backup & Restore, System Log, and Logout. The main content area is titled "RF Firmware Upgrade" and contains the following text: "This page applies a firmware for RF update to your alarm panel. You should only apply updates with the correct firmware." Below this, it states "Your current firmware version is: HPGW-L2-XA24". There is a "Firmware File:" label followed by a "Choose File" button and the text "No file chosen". A paragraph of instructions follows: "To locate the correct file, click on the browse file button and find the directory you downloaded it to. Click on the file and then OK. When the filename appears in the box, click the apply button. DO NOT interrupt the update process." At the bottom of the main content area is an "Apply" button. In the bottom right corner of the interface, the copyright notice "@2014 Climax Tech. Co., Ltd." is visible.

Step 2. Press “**Apply**” to upload the latest firmware to Control Panel

Step 3. Wait for 1 min and do NOT power off during this time.

Step 4. Once Firmware upgrading is complete, the Control Panel will reboot automatically

8.18. Factory Reset

You can clear all programmed parameters in the Control Panel and reset it to Factory Default.

Once the **Factory Reset** is executed, all the programmed settings will be returned to its default value, and all the learnt-in devices will be removed. You will need to restart the programming and learning process again.

Remote Reset

- Step 1.** Tick the **Kept current network setting** box to keep the current Network settings. Otherwise, the system will reset its value back to factory default.
- Step 2.** Press **Yes** to continue the Reset procedure.
- Step 3.** Wait for 1 min and do NOT power off during this time.
- Step 4.** Once reset is complete, it will automatically reboot the main unit.

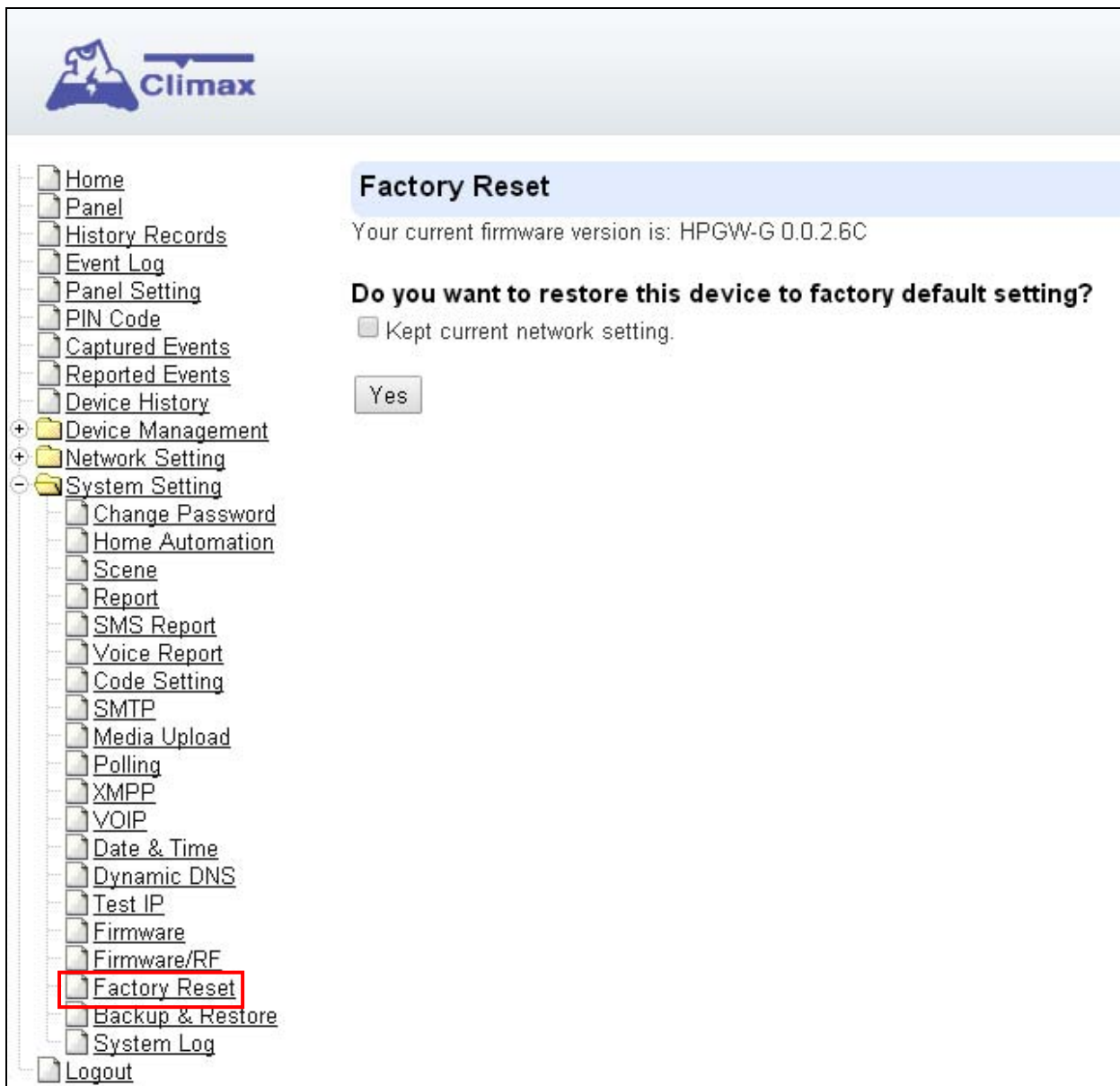

Local Reset

Step 1. Remove the batteries and disconnect the AC adaptor, slide battery switch to OFF.

Step 2. Press and Hold the reset button and connect the AC adaptor to the Control Panel. All 3 LEDs will turn on for 10 seconds.

Step 3. Keep holding the reset button for 30 seconds then release. After 10 seconds, the Control Panel will restart and all 3 LEDs will turn on.

Step 4. Wait for 10 seconds and all 3 LEDs will turn off to indicate factory reset is complete.

8.19. Backup & Restore

You can backup all programmed parameters and save these programmed values into a file. Besides, you also can restore pre-programmed settings.

8.19.1 Backup Data

You can backup all programmed data and save these programmed values into a file.

Step 1. Click **Download configuration file**.

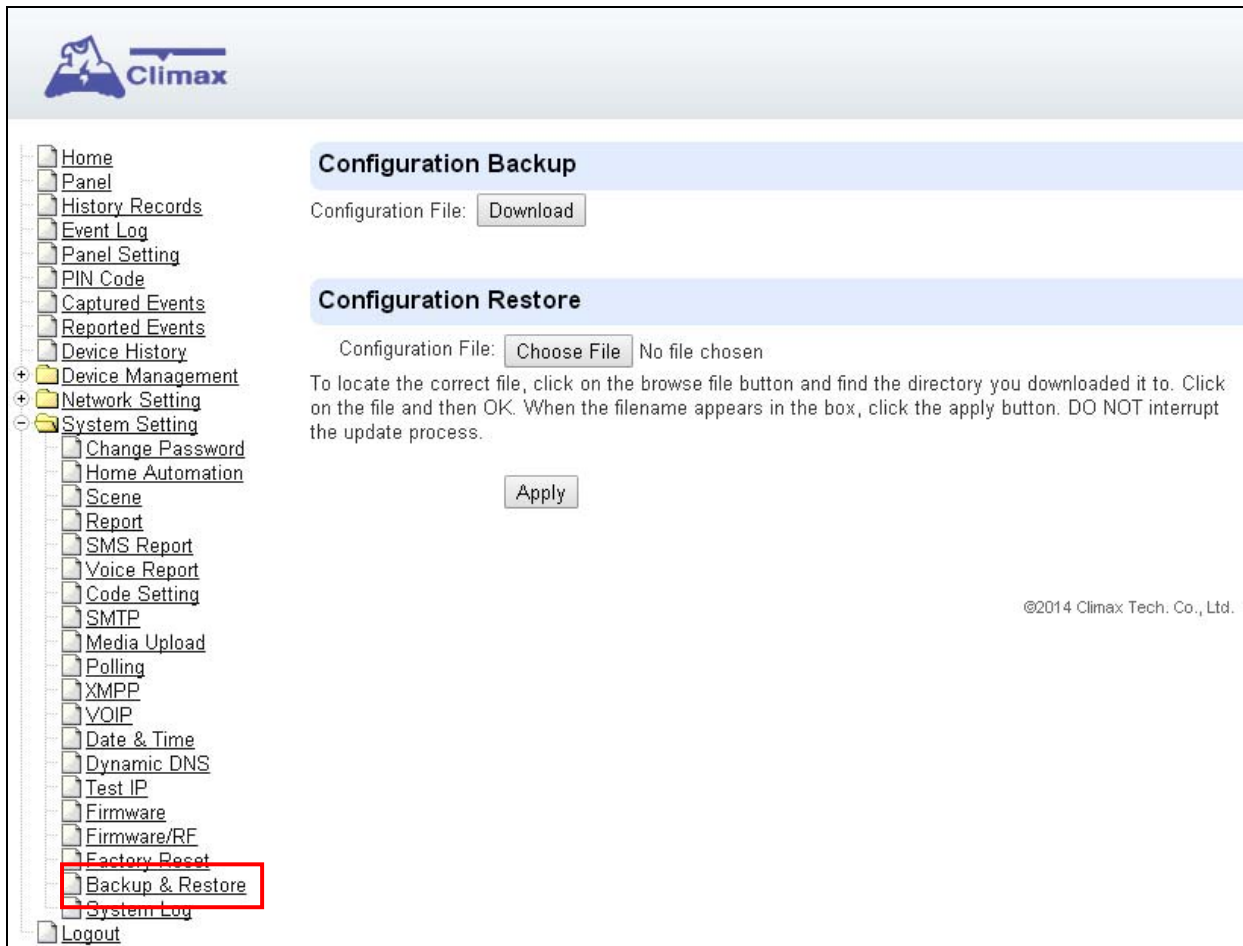

The screenshot shows the Climax web interface. On the left is a navigation tree with the following items: Home, Panel, History Records, Event Log, Panel Setting, PIN Code, Captured Events, Reported Events, Device History, Device Management, Network Setting, System Setting (expanded), Change Password, Home Automation, Scene, Report, SMS Report, Voice Report, Code Setting, SMTP, Media Upload, Polling, XMPP, VOIP, Date & Time, Dynamic DNS, Test IP, Firmware, Firmware/RF, Factory Reset, Backup & Restore (highlighted with a red box), System Log, and Logout. The main content area has two sections: 'Configuration Backup' with a 'Download' button, and 'Configuration Restore' with a 'Choose File' button and the text 'No file chosen'. Below the restore section is an 'Apply' button and a copyright notice: '©2014 Climax Tech. Co., Ltd.'

Step 2. Click **Download configuration file**.

8.19.2 Restore Settings

Step 1. Click **Browse**, select a saved file.

Step 2. Click **Apply** to apply the pre-programmed values to the main unit.

8.20. System Log

The system log webpage logs the control panel's detail system operation history.

System Log

Reload

Time	Priority	Class	Action	Source	Message
2014/12/12 05:39:15	6	30	Wireless LAN	Worker	Disconnected
2014/12/12 05:39:14	6	30	Wireless LAN	Worker	Disconnected
2014/12/12 05:38:48	6	30	Wireless LAN	Worker	Disconnected
2014/12/12 05:38:47	6	30	Wireless LAN	Worker	Disconnected
2014/12/12 05:37:48	6	30	Wireless LAN	Worker	Disconnected
2014/12/12 05:37:47	6	30	Wireless LAN	Worker	Disconnected
2014/12/12 05:37:39	6	30	Wireless LAN	Worker	Disconnected
2014/12/12 05:37:38	6	30	Wireless LAN	Worker	Disconnected
2014/12/12 05:37:26	6	30	Wireless LAN	Worker	Disconnected
2014/12/12 05:37:25	6	30	Wireless LAN	Worker	Disconnected
2014/12/12 05:37:16	6	30	Wireless LAN	Worker	Disconnected
2014/12/12 05:37:12	6	30	Wireless LAN	Worker	Disconnected
2014/12/12 05:37:11	6	30	Wireless LAN	Worker	Disconnected
2014/12/12 05:36:59	6	30	Wireless LAN	Worker	Disconnected
2014/12/12 05:36:58	6	30	Wireless LAN	Worker	Disconnected
2014/12/12 05:36:50	6	30	Wireless LAN	Worker	Disconnected
2014/12/12 05:36:49	6	30	Wireless LAN	Worker	Disconnected
2014/12/12 05:36:31	6	30	Wireless LAN	Worker	Disconnected
2014/12/12 05:36:30	6	30	Wireless LAN	Worker	Disconnected
2014/12/12 05:36:18	6	30	Wireless LAN	Worker	Disconnected

Limit # of items: 20

System Log File: [Download](#)

- **System Log File Download** Click to download a detail log files into your computer for more information.

9. Event & History

This section introduces event history of the system.

9.1. Captured Events

This page stores all captured pictures and videos by PIR Camera and PIR Video Camera. When a PIR Camera is triggered, it will take 3 pictures in quick succession, when a PIR Video Camera is triggered, it will take a 10-second video clip. You can also request the PIR Camera to take a picture and PIR Video Camera to take a 10-second video clip manually.

Captured events will be displayed in this page with their information for you to view. Simply click on the picture or video to view them. You can also click **Delete** to delete the event.

The screenshot shows the Climax web interface. On the left is a navigation menu with items like Home, Panel, History Records, Event Log, Panel Setting, PIR Code, Captured Events (highlighted with a red box), Reported Events, Device History, Device Management, Network Setting, System Setting, and Logout. The main content area is titled 'Captured Events' and features a 'Reload' button. Below is a table with the following data:

Time	Area	Zone	Type	Status	Media	Comment	
2012-09-12 16:24:52	1	10	Requested	Done		No Packet Lost;	Delete
2012-08-28 14:30:42			Requested	Done	Video	No Packet Lost;	Delete
2012-08-28 14:21:12			Requested	Done	Video	No Packet Lost;	Delete

At the bottom of the table, there is a 'Limit # of items' dropdown menu set to 10.

- **Reload** : Click to refresh the page content
- **Limit # of Items**: Click the drop down menu on the pageto select the numbers of captured events you want to display.

9.2. Reported Events

This page stores all triggered events by the control panel by recording the events' CID event code and report status.

Reported Events

Reload

Time	Area	Zone / User	Trigger / Restore	CID event	Message	Report Status	Comment
2012-09-12 15:09:37	1	6	Trigger	383	Tamper	Done	
2012-09-12 14:49:33	1	5	Trigger	383	Tamper	Done	
2012-09-12 14:49:27	1	5	Restore	383	Tamper Restore	Done	
2012-09-12 14:48:57	1	5	Trigger	383	Tamper	Done	
2012-09-12 14:48:56	1	5	Restore	383	Tamper Restore	Done	
2012-09-12 14:48:51	1	5	Trigger	383	Tamper	Done	
2012-09-12 14:48:49	1	5	Restore	383	Tamper Restore	Done	
2012-09-12 14:45:07	1	5	Trigger	383	Tamper	Done	
2012-09-12 14:45:05	1	5	Restore	383	Tamper Restore	Done	
2012-09-12 14:43:29	1	5	Trigger	383	Tamper	Done	
2012-09-12 14:43:27	1	5	Restore	383	Tamper Restore	Done	
2012-09-12 14:42:46	1	5	Trigger	383	Tamper	Done	
2012-09-12 04:04:16	1	1	Trigger	147	Supervision Failure	Done	
2012-09-12 04:04:16	1	3	Trigger	147	Supervision Failure	Done	
2012-09-12 04:04:15	1	2	Trigger	147	Supervision Failure	Done	
2012-09-11 16:35:18	0	0	Trigger	311	Panel Battery Missing/Dead	Done	
2012-09-11 16:04:16	0	0	Trigger	137	Panel Tamper	Done	
2012-09-11 10:40:58	0	0	Trigger	311	Panel Battery Missing/Dead	Done	
2012-09-11 10:16:07	0	0	Trigger	137	Panel Tamper	Done	
2012-08-28 19:18:02	1	1	Trigger	383	Tamper	Done	

Limit # of items: 20

- **Reload** : Click to refresh the page content
- **Limit # of Items**: Click the drop down menu on the pageto select the numbers of captured events you want to display.

9.3. Event Log

The Event Log page records specific actions performed by the Control Panel and accessory devices.

Time	Area	Mode	Action	User	Source	Device Type	Message
2015/01/12 05:26:09			Switch To Standard Mode		Panel		Web
2015/01/12 05:25:35	1		Device Added		Zone4	IP Camera	Web
2015/01/12 05:25:04			Switch To Learn Mode		Panel		Web
2015/01/12 05:25:03			Switch To Standard Mode		Panel		Web
2015/01/12 05:23:49			Switch To Learn Mode		Panel		Web
2015/01/12 04:09:49			Switch To Standard Mode		Panel		Web
2015/01/12 04:08:20			System Fault		Panel		Area1Zone1 Tamper; Area1Zone3 Tamper
2015/01/12 04:08:20	1	Disarm	Device Tamper		Zone3	IR Camera	Trigger
2015/01/12 04:04:48			Switch To Learn Mode		Panel		Web
2015/01/12 04:04:45			Switch To Standard Mode		Panel		Web
2015/01/12 04:03:31	1		Device Added		Zone3	IR Camera	Web
2015/01/12 04:02:32	1		Device Added		Zone2	Dimmer	Web
2015/01/12 04:01:38			Switch To Learn Mode		Panel		Web
2015/01/12 03:41:13			System Fault		Panel		Area1Zone1 Tamper
2015/01/12 03:41:12	1	Disarm	Ignored		Zone1	Door Contact	Tamper Ignored
2015/01/12 03:41:12	1	Disarm	Device Tamper		Zone1	Door Contact	Trigger
			System Fault		Panel		Restore
			System Fault		Panel		Network Cable Unplugged; ZigBee Not Ready
			Initialize		Panel		Ready
2015/01/12 03:16:07			System Fault		Panel		Area1Zone1 Tamper

- **Reload** : Click to refresh the page content
- **Limit # of Items**: Click the drop down menu on the pageto select the numbers of captured events you want to display.

9.4. Device History

You can track your ZigBee accessory device status history under **Device History**. For Power Switch Meter or Temperature Sensor, the update history power consumption or temperature reading will be displayed under this page (the current info is also displayed under **Panel** and **PSS Control**).

The screenshot shows the Climax web interface. The sidebar menu on the left includes: Home, Panel, History Records, Event Log, Panel Setting, PIN Code, Captured Events, Reported Events, **Device History** (highlighted with a red box), Device Management, Network Setting, System Setting, and Logout. The main content area is titled 'Device History' and features a 'Reload' button. Below the button is a table with the following data:

Date Time	Area	Zone	Name	Information	Value
2015-01-12 05:42:29	1	2		Energy	2.5kWh
2015-01-12 05:42:29	1	2		Active Power	0.0W
2015-01-12 05:32:29	1	2		Energy	2.5kWh
2015-01-12 05:32:29	1	2		Active Power	0.0W
2015-01-12 05:22:29	1	2		Energy	2.5kWh
2015-01-12 05:22:29	1	2		Active Power	0.0W
2015-01-12 05:12:29	1	2		Energy	2.5kWh
2015-01-12 05:12:29	1	2		Active Power	0.0W
2015-01-12 05:02:29	1	2		Energy	2.5kWh
2015-01-12 05:02:29	1	2		Active Power	0.0W
2015-01-12 04:52:29	1	2		Energy	2.5kWh
2015-01-12 04:52:29	1	2		Active Power	0.0W
2015-01-12 04:42:29	1	2		Energy	2.5kWh
2015-01-12 04:42:29	1	2		Active Power	0.0W
2015-01-12 04:32:29	1	2		Energy	2.5kWh
2015-01-12 04:32:29	1	2		Active Power	0.0W
2015-01-12 04:22:29	1	2		Energy	2.5kWh
2015-01-12 04:22:29	1	2		Active Power	0.0W
2015-01-12 04:12:29	1	2		Energy	2.5kWh
2015-01-12 04:12:28	1	2		Active Power	0.0W

At the bottom of the table, there is a 'Limit # of items:' dropdown menu currently set to 20.

- **Reload** : Click to refresh the page content
- **Limit # of Items**: Click the drop down menu on the pageto select the numbers of captured events you want to display.

10. SMS Programming Command

- **SMS Remote Programming Command Table**

If the SMS Program Word (SMS P-Word) is set as **PROG**, and default Install Code is **7982**.

ITEM	COMMAND	USAGE	DESCRIPTION
SMS Keyword	KEYWD	SMSKEY: PROG,7982,PROG1	It is used to change the SMS keyword
IP Setting	GAPN	GAPN: PROG,7982,internet,user,pass word	Enter the APN Server detail (provided by your telecom supplier)
Polling Setting	POLL	POLL: PROG,7982,1,ip://59.124.123.23:80/resp.php, 300	It is used for polling. 1 → URL number. It can be 1, 2. 2 URL(s) can be set. ip://59.124.123.23:80/resp.php → polling URL 300 → polling interval time, 300 seconds
Request Polling	POLLI	POLLI: PROG,7982	It is used to request polling immediately.
Reset	RESET	RESET: PROG,7982,20	It is used to reset the system. 20 → delay 20 seconds to reset the system.

<NOTE>

1. If you don't want to get a confirmation message to know whether your setting is correct or not, you can add "nak" to the programming command, such as "RESET:PROG,7982,20,nak". The system will not return you a confirmation message to confirm that your setting is successful.
2. Use comma (,) to separate each programming value such as "MODE:PROG,7982,1".
3. SMS P-Word can be changed (refer to page 31 for details). Install Code 7982 is fixed and can not be changed.

11. SMS User Command

- SMS User Command

If the SMS Keyword is set as **Joe**, and default user pin code 1 is **1234**.

ITEM	COMMAND	USAGE	DESCRIPTION
Panel Mode	MODE	MODE:Joe,1234,1,4	It is used to change the arming mode. First value (1) → area number Second value(4) → Home Arm 3 mode 0: Disarm 1: Full Arm 2: Home Arm 1 3: Home Arm 2 4: Home Arm 3
Request Image	REQIMG	REQIMG:Joe,7982,1,10	It is used to request PIR camera to take a picture. First value (1) → Area Number; Second value (10)→ PIR Camera Zone Number.
Power Switch On/ Off/ Toggle	PSS	PSS:Joe,1234,1,2,0	It is used to switch on/ off/ toggle power switch. First value (1) → Area Number, 1 for Area 1, 2 for Area 2 Second value (2) → PSS zone number Third value (0) → action, 0 for switch off, 1 for switch on, 2 for toggle
Reset	RESET	RESET:Joe,1234,10	It is used to reset the system. 10→ delay 10 seconds to reset the system.

<NOTE>

1. If you don't want to get a confirmation message to know whether your setting is correct or not, you can add "nak" to the programming command, such as "PSS:Joe,1234,1,2,0,nak". The system will not return you a confirmation message to confirm that your setting is successful.
2. Use comma (,) to separate each programming value such as "MODE:Joe,1234,1".
3. SMS Keyword and user pin code 1 can be changed.

12. Appendix

12.1. Contact-ID Protocol & Format

Where	ACCT MT QXYZ GG C₁C₂C₃																									
ACCT	= 4 Digit Account number (0-9, B-F)																									
MT	= Message Type, 18H.																									
Q	= Event qualifier, which gives specific event information:																									
XYZ	= Event code (3 Hex digits 0-9, B-F)																									
GG	= Group, Partition number (00H), or Area Number - 00 = panel - 01= area 1.....xx= area xx																									
C ₁ C ₂ C ₃	= 1. For devices: zone <table border="1" data-bbox="635 972 1024 1200"> <tr> <td>C₁C₂C₃ = Zone number</td> </tr> <tr> <td>001, Zone 1</td> </tr> <tr> <td>002, Zone 2</td> </tr> <tr> <td>.....</td> </tr> <tr> <td>XXX Zone XXX</td> </tr> </table> 2. For Panel: code <table border="1" data-bbox="635 1299 1000 1792"> <tr> <td>C₁C₂C₃ =</td> <td></td> </tr> <tr> <td>User PIN Code 1</td> <td>001</td> </tr> <tr> <td>User PIN Code 2</td> <td>002</td> </tr> <tr> <td>User PIN Code 3</td> <td>003</td> </tr> <tr> <td>User PIN Code 4</td> <td>004</td> </tr> <tr> <td>User PIN Code 5</td> <td>005</td> </tr> <tr> <td>User PIN Code 6</td> <td>006</td> </tr> <tr> <td>Temporary Code</td> <td>997</td> </tr> <tr> <td>Duress Code</td> <td>998</td> </tr> <tr> <td colspan="2">000= Control Panel</td> </tr> </table>	C₁C₂C₃ = Zone number	001, Zone 1	002, Zone 2	XXX Zone XXX	C₁C₂C₃ =		User PIN Code 1	001	User PIN Code 2	002	User PIN Code 3	003	User PIN Code 4	004	User PIN Code 5	005	User PIN Code 6	006	Temporary Code	997	Duress Code	998	000= Control Panel	
C₁C₂C₃ = Zone number																										
001, Zone 1																										
002, Zone 2																										
.....																										
XXX Zone XXX																										
C₁C₂C₃ =																										
User PIN Code 1	001																									
User PIN Code 2	002																									
User PIN Code 3	003																									
User PIN Code 4	004																									
User PIN Code 5	005																									
User PIN Code 6	006																									
Temporary Code	997																									
Duress Code	998																									
000= Control Panel																										

12.2. Event Code

- **100 – Medical**
- **101 – Personal emergency**
 - ◆ When the Wrist Transmitter (WTR) is pressed.
- **110 – Fire**
- **111 – Smoke**
 - ◆ When the Smoke Detector (SD) is triggered.
- **120 – Panic**
 - ◆ When the Panic Button of the Remote Controller (RC) is pressed.
- **121 – Duress**
 - ◆ When the Duress Code is entered to disarm or arm the system.
- **122 – Silent Panic**
 - ◆ When the Panic Button of the Remote Controller \ WTR is pressed.
- **130 – Burglar**
 - ◆ When a device whose attribute is set as **Burglar** or **Burglar Follow** is triggered.
- **131 – Burglar Perimeter**
 - ◆ When a device set as **Entry** is triggered in the arm mode.
- **132 – Burglar Interior**
 - ◆ When a device set at **Entry** is triggered in the home mode.
- **136 – Burglar Outdoor**
 - ◆ When any device set at **Burglar Outdoor** is triggered.
- **137 – Panel Tamper/ Panel Tamper Restore**
 - ◆ When the panel's tamper protection is triggered.
 - ◆ When the panel's tamper function is restored.
- **147 – Sensor Supervision Failure/ Sensor Supervision Restore**
 - ◆ When the control panel can't receive the signal transmitted from any one of the devices individually for a preset time.
 - ◆ When the supervision function of sensor is restored.
- **154 – Water leakage**
 - ◆ When the Water Sensor connected to Door Contact set at **Water (@W)** is triggered.
- **158 – High Temperature Alarm**
 - ◆ When high temperature alarm is triggered.
- **159 – Low Temperature Alarm**
 - ◆ When low temperature alarm is triggered.
- **162 – CO Alarm**
- **170 – High Power Consumption**
 - ◆ When high power consumption alarm is triggered.
- **171 – High Humidity Alarm**

- ◆ When high humidity alarm is triggered.
- **172 – Low Humidity Alarm**
 - ◆ When low humidity alarm is triggered.
- **301 – AC Failure/ AC Power Restore**
 - ◆ When the AC power fails for more than 10 sec.
 - ◆ Restore from AC power failure.
- **302 – Low battery/ Battery Normal**
 - ◆ When the battery voltage of the Panel is low.
 - ◆ When the panel battery restores voltage.
- **311 – Battery Disconnection/ Battery Reconnected**
- **344 – Interference/ Interference problem solved**
- **358 – Network Cable Unplugged**
 - ◆ When the Ethernet cable is disconnected.
- **359 – GSM No Signal**
 - ◆ When the panel loses GSM signal.
- **374 – Force Arm**
 - ◆ Whenever there is a fault situation occurred in the system, any arming activity will enable the system to send a force arm code.
- **380 – Device AC Failure**
 - ◆ When an AC power device loses AC power connection.
- **383 – Sensor Tamper/ Sensor Tamper Restore**
 - ◆ When any sensor's tamper protection is triggered.
 - ◆ When the sensor's tamper function is restored.
- **384 – Sensor Low battery/ Sensor Battery Normal**
 - ◆ When the battery voltage of any one of the devices is low.
 - ◆ When any device's battery restores voltage.
- **400 – Arm/Disarm (by Remote Controller)**
 - ◆ When the system is armed or disarmed by using the Remote Controller.
- **401 – Remote Arm/Disarm**
 - ◆ When the system is armed or disarmed by SMS message or web access
- **407 – Disarm/Away Arm/Home Arm by Remote Keypad**
- **408 – Set/Unset Arm/Disarm**
 - ◆ When the DC set at Set\Unset is triggered.
- **456 - Partial Arm**

- ◆ When partially arm the system from Disarm to Home arm
- **570 – Device out of order/ Door Contact Not Closed**
 - ◆ When any device is out of order after the preset exit delay time is reached
 - ◆ Door Contact is not closed after the preset exit delay time is reached.
- **602 – Periodic test report**
 - ◆ When the control panel makes periodic Check-in reporting.
- **616 – Call Request**
 - ◆ When the service call is activated by VST-809.

Federal Communication Commission Interference Statement

This equipment has been tested and found to comply with the limits for a Class B digital device, pursuant to Part 15, 22, 24 of the FCC Rules. These limits are designed to provide reasonable protection against harmful interference in a residential installation.

This equipment generates, uses and can radiate radio frequency energy and, if not installed and used in accordance with the instructions, may cause harmful interference to radio communications. However, there is no guarantee that interference will not occur in a particular installation. If this equipment does cause harmful interference to radio or television reception, which can be determined by turning the equipment off and on, the user is encouraged to try to correct the interference by one of the following measures:

- . Reorient or relocate the receiving antenna.
- . Increase the separation between the equipment and receiver.
- . Connect the equipment into an outlet on a circuit different from that to which the receiver is connected.
- . Consult the dealer or an experienced radio/TV technician for help.

FCC Caution: To assure continued compliance, any changes or modifications not expressly approved by the party responsible for compliance could void the user's authority to operate this equipment. (Example - use only shielded interface cables when connecting to computer or peripheral devices).

FCC Radiation Exposure Statement

This equipment complies with FCC RF radiation exposure limits set forth for an uncontrolled environment. This equipment should be installed and operated with a minimum distance of 20 centimeters between the radiator and your body.

This transmitter must not be co-located or operating in conjunction with any other antenna or transmitter.

The antennas used for this transmitter must be installed to provide a separation distance of at least 20 cm from all persons and must not be co-located or operating in conjunction with any other antenna or transmitter.

This device complies with Part 15, 22, 24 of the FCC Rules. Operation is subject to the following two conditions:

- (1) This device may not cause harmful interference, and
- (2) This device must accept any interference received, including interference that may cause undesired operation.