

Panic Button (PB-15)

The Panic Button is used to activate (or deactivate) a panic alarm.

● Parts

1. Panic Button / LED Indicator

Button usage:

1. Press to send a learn code or activate a panic alarm.
2. Press and hold the button for 8 seconds to send a Cancel Code to the Control Panel. (This function is not compatible with every control panel)

LED Indicator:

The LED indicator will light up briefly when the device is transmitting a signal.

2. Cover-Fixing Screw

3. Fixing Hook

4. Battery Compartment

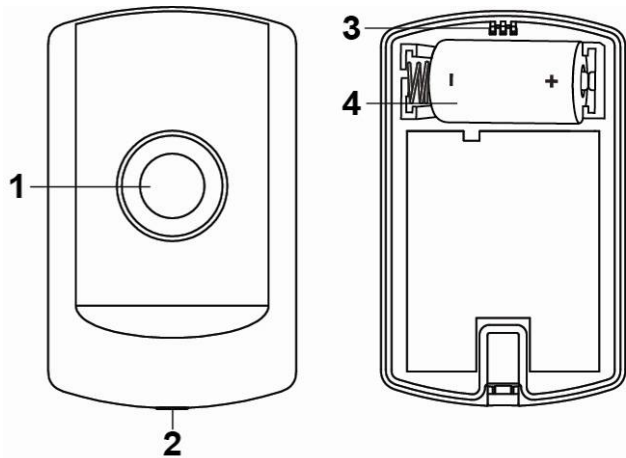

● Battery

- The Panic Button is powered by one CR2 3V Lithium battery.
- The Panic Button will transmit any detected low battery status along with any regular status signal transmission to the Control Panel for display accordingly.
- When changing battery, after removing the old battery, press the button twice to fully discharge before inserting new battery.

● Supervisory Signal

- The Panic Button will automatically transmit Supervisory Signals every 30 to 50 minutes.
- If the Control Panel has not received the signal from the Panic Button for a preset period of time, the Control Panel will indicate that the Panic Button is out-of-signal range or is out of order.

● Getting Started

- Remove the cover-fixing screw using a Philips screwdriver and separate the cover from the base.
- Insert the battery according to the marked polarities.
- Replace the top over the base by hooking the base onto the fixing hook and pushing the cover towards the base.
- Lightly tighten the screw.
- Put Control Panel into learn mode
- Press the button on the Panic Button to transmit a learn code.
- Refer to your Control Panel's operation manual to complete the learn-in process.

● Walk Test

- Place the Control Panel in the walk test mode.
- Press the Button once.
- The Panel will display the RSSi (Radio Strength Signal) strength and sound a 2-tone beep.

● Operation

- After the Panic Button is learned successfully, press the Button to activate a Panic Alarm.
- Press and hold the Button for 8 seconds or more will send a Cancel Code to the Control Panel to stop the alarm. (This function is not compatible with all control panels.)

● Mounting the Panic Button

The Panic Button can be mounted using two methods: Self-adhesive or Screw mounting.

● Self adhesive mounting

- I. Clean the surface with a suitable degreaser.
- II. Remove the protective covering from one side of double-sided adhesive pad and firmly apply to the back of the device.
- III. Remove the other covering and firmly place/press the device in the desired location.

< NOTE >

- ☞ Do not use the Self-adhesive mounting method on poorly painted and/or rough surfaces.

● Screw Mounting

The base has two screw knockouts, where the plastic is thinner for mounting purposes. To mount the Panic Button:

- I. Remove the cover-fixing screw and separate the top cover from the base.
- II. Break through the knockouts on the base.
- III. Use the holes as a template to drill two holes and insert the wall plugs.
- IV. Screw the base into the wall plugs.
- V. Replace the top over the base by hooking the base onto the fixing hook and pushing the cover towards the base.
- VI. Lightly tighten the screw.

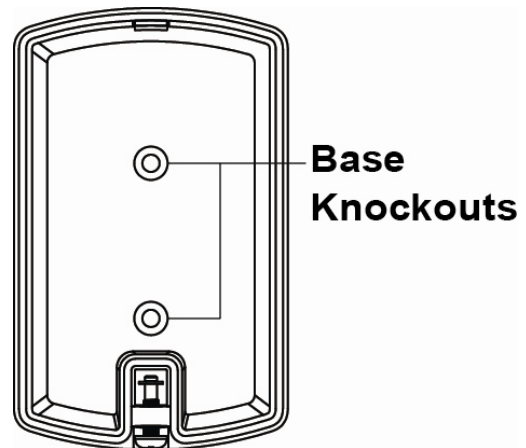

This device complies with Part 15 of the FCC Rules. Operation is subject to the following two conditions:

- (1) This device may not cause harmful interference, and
- (2) This device must accept any interference received, including interference that may cause undesired operation.