



MT-3 RADIO SYSTEMS

PAGING MODULATOR INSTRUCTION MANUAL CI-PM-3

Covers models: CI-PM-3-00

Copyright © 2002 Daniels Electronics Ltd. All rights reserved. No part of this publication may be reproduced, stored in a retrieval system or transmitted in any form or by any means, electronic, mechanical, photocopying, recording or other wise, without the prior written consent of Daniels Electronics Ltd.

DE™ is a registered trademark of Daniels Electronic Ltd. registered in the United States Patent and Trademark Office.

Printing Date: Dec 2002

Issue Date: **February 2002**

Issue: **4 Rev A**

Part No.: **IM55-CIPM3**

Previous Issue Date: Nov 99

Previous Issue: 3

Daniels Electronics Ltd.

Victoria, BC

PRINTED IN CANADA

Reviewed By:

Quality Assurance:

CLAUDIABOORMAN

Quality Administrator

C. Boorman

Signature

FEB 12, 2002

Date

NOTE:

The user's authority to operate this equipment could be revoked through any changes or modifications not expressly approved by Daniels Electronics Ltd.

The design of this equipment is subject to change due to continuous development. This equipment may incorporate minor changes in detail from the information contained in this manual.

TABLE OF CONTENTS

	Page
1 GENERAL.....	1-1
1.1 Introduction	1-1
1.2 Construction	1-2
1.3 Printed Circuit Board Numbering Convention.....	1-2
1.4 Specifications.....	1-2
1.4.1 General Specifications	1-2
1.4.2 CTCSS Decoder/Encoder (Option)	1-4
1.4.3 Physical Specifications	1-5
2 THEORY OF OPERATION.....	2-1
2.1 Paging Signal Path.....	2-1
2.1.1 2-Level Digital Paging	2-1
2.1.1.1 Self Test Circuitry.....	2-2
2.1.2 4-Level Digital Paging	2-2
2.1.3 Analog Paging	2-3
2.1.4 Front Panel Indicator Circuitry	2-4
2.1.4.1 Data Indicator Circuitry	2-4
2.1.4.2 Analog / Digital Indicator Circuitry.....	2-4
2.1.4.3 LED Power.....	2-4
2.2 OCXO/PLL	2-5
2.2.1 Standard Frequency Reference	2-5
2.2.2 High Stability Frequency Reference	2-5
2.3 Configuration Options.....	2-6
2.3.1 Simultaneous Broadcasting (2 Level Paging Only).....	2-6
3 ALIGNMENT PROCEDURE AND INSTALLATION	3-1
3.1 General	3-1
3.2 Repair Notes.....	3-1
3.3 Recommended Equipment List	3-1
3.4 Installation	3-2
3.5 Alignment	3-2
3.6 Frequency (Digital Paging) Adjustment.....	3-2
3.7 Reference (Analog Paging) Adjustment.....	3-3
3.8 Test Data Symmetry Adjustment	3-3
3.9 2 And 4 Level Deviation Adjustment.....	3-3
3.10 PLL Setup.....	3-4
3.11 Data Delay Setup.....	3-5
3.12 Simulcast Delay Setup.....	3-6

ALIGNMENT PROCEDURE AND INSTALLATION CONTINUED

3.13	Repeater Configuration.....	3-8
3.13.1	Base Transmitter Site CI-PM-3 Configuration	3-8
3.13.1.1	Digital-Only Paging.....	3-8
3.13.1.2	Analog/Digital Paging.....	3-8
3.13.2	Repeater Site CI-PM-3 Configuration	3-8
3.13.2.1	Digital-Only Repeater.....	3-9
3.13.2.2	Analog/Digital Repeater.....	3-9
3.13.3	TS-64 Configuration.....	3-9
4	CONNECTOR PIN FUNCTIONS AND JUMPER FUNCTIONS.....	4-1
4.1	Data / Control Port (Connector J1) Pin Functions.....	4-1
4.2	Motherboard Interface (Connector P1) Pin Functions.....	4-1
4.3	CI-PM-3 Data Delay Jumper Settings.....	4-3
4.4	CI-PM-3 Circuit Board Jumpers	4-4
4.5	TS-64 MOD1 Jumper Settings - (If installed).....	4-5
4.6	4-Level Modulation Bit Pattern.....	4-5
4.7	Receiver IF / Audio PCB Jumper Settings.....	4-5
4.8	Transmitter Audio Processor Jumper Settings.....	4-6
4.9	Transmitter Synthesizer Jumper Settings.....	4-9
4.10	CI-PM-3 Test Points	4-10
5	ILLUSTRATIONS AND SCHEMATIC DIAGRAMS	5-1
5.1	CI-PM-3 Front Panel Controls.....	5-1
5.2	Simulcast Paging Example.....	5-2
5.3	CI-PM-3 Component Layout (Through-Hole Side)	5-3
5.4	CI-PM-3 Component Layout (Surface-Mount Side).....	5-4
5.5	CI-PM-3 Schematic Diagram	5-5
5.6	CI-PM-3 Schematic Diagram	5-6
5.7	CI-PM-3 Schematic Diagram Component Location Table.....	5-7
6	PARTS LISTS	6-1
6.1	CI-PM-3 Electrical Parts List.....	6-1
6.2	CI-PM-3 Mechanical Parts List.....	6-5
7	REVISION HISTORY.....	7-1

LIST OF TABLES

	Page
Table 4-1	Data / Control Port (Connector J1) Pin Functions..... 4-1
Table 4-2	Motherboard Interface Connector P1 Pin Functions..... 4-1
Table 4-3	Delay Settings..... 4-3
Table 4-4	CI-PM-3 Default Jumper Settings..... 4-4
Table 4-5	CTCSS Jumper Settings..... 4-5
Table 4-6	4-Level Modulation Bit Pattern..... 4-5
Table 4-9	Receiver IF / Audio PCB Jumper Settings..... 4-5
Table 4-7	Transmitter Audio Processor V1.6 Jumper Settings 4-6
Table 4-8	Transmitter Audio Processor V1.8 Jumper Settings 4-6
Table 4-9	Transmitter Audio Processor V2.3 Jumper Settings 4-8
Table 4-10	CI-PM-3 Test Points 4-10
Table 4-11	Component Location Table Schematic..... 5-7

LIST OF ILLUSTRATIONS

	Page
Figure 4-1	Transmitter Audio Processor V1.6 Jumper Settings 4-6
Figure 4-2	Transmitter Audio Processor V1.8 Jumper Settings 4-6
Figure 4-3	Transmitter Audio Processor V2.3 Jumper Settings 4-8
Figure 4-4	VHF and (400 MHz) UHF Synthesizer Analog PCB Jumper Settings..... 4-9
Figure 4-5	VHF and (400 MHz) UHF Synthesizer Digital PCB Jumper Settings 4-9
Figure 4-5	800MHz and 900MHz Transmitter Synthesizer Jumper Settings 4-9
Figure 5-1	CI-PM-3 Front Panel Controls..... 5-1
Figure 5-2	Simulcast Paging Example..... 5-2
Figure 5-3	CI-PM-3 Circuit Board (Through-Hole Side) 5-3
Figure 5-4	CI-PM-3 Circuit Board (Surface-Mount Side)..... 5-4
Figure 5-5	CI-PM-3 Circuit Board Schematic Diagram..... 5-5

This Page Intentionally Left Blank.

1 GENERAL

1.1 Introduction

The CI-PM-3 Paging Modulator module is an optional plug-in component of the MT-3 Radio Repeater System. This module provides digital and/or analog paging capability for Daniels MT-3 transmitters in all supported frequency bands.

The CI-PM-3 is designed for low power consumption, typically drawing less than 250 mA in steady state. In its standard configuration, the CI-PM-3 uses an on-board frequency reference source consisting of a 10 MHz OCXO with a standard stability of 0.03 PPM. For high stability applications (such as Simulcast), the CI-PM-3 Paging Modulator may be configured to use an external high stability reference source (i.e. rubidium, GPS or WWV) with a standard stability greater than or equal to 0.002 PPM, to discipline the on-board phase-locked loop OCXO oscillator. To ensure that paging signals are the same relative to each transmitter, the CI-PM-3 also incorporates a limited delay compensation for the different link propagation paths between transmitters.

The CI-PM-3 Paging Modulator supports both analog and digital paging formats, and can transmit POCSAG and other 2-level modulation schemes at data transfer rates of 512, 1200, and 2400 Baud. It can also be configured for use as a data repeater, whereby 2-level paging data is recovered, re-shaped and then re-transmitted to an additional repeater/paging transmitter. The CI-PM-3 supports 4-level modulation formats in non-repeater mode (i.e. in a base station paging transmitter application only) at data transfer rates up to 1600 BPS. Each of the four modulation deviation levels can be independently set, making the CI-PM-3 suitable for use in such pager signaling schemes as Motorola's FLEX™ Paging Protocol.

Setup conditions are established via front panel switch settings, while internal jumper settings and setup adjustments are easily accessible using the EC-96, 96 Pin Extender Card.

The CI-PM-3 Paging Modulator includes the following standard features:

- low power analog and CMOS control circuitry.
- extended operating temperature range;
- jumper selectable Repeater/paging transmitter configuration;
- on-board +/-0.03 PPM 10 MHz OCXO;
- front panel selection of PLL OCXO using external high stability frequency reference;
- jumper and line selectable analog / digital paging configuration;
- connection for optional CTCSS encoder / decoder;
- balanced 600 Ω / single-ended microphone input;
- selectable digital delay for Simulcast operation

1.2 Construction

The CI-PM-3 Paging Modulator is packaged in a compact Eurostandard shell module housing of nickel/steel with an anodized aluminum front panel. Corrosion resistant fasteners are used throughout the assembly.

1.3 Printed Circuit Board Numbering Convention

To ease troubleshooting and maintenance procedures, Daniels Electronics Limited has adopted a printed circuit board (PCB) numbering convention in which the last two digits of the Circuit Board number represent the Circuit Board version. For example:

- PCB number 50002-02 indicates Circuit Board version 2.0.
- PCB number 43-912010 indicates Circuit Board version 1.0;

All PCB's manufactured by Daniels Electronics are identified by one of the above conventions.

1.4 Specifications

1.4.1 General Specifications

Model Number:	CI-PM-3
Type:	MT-3 Series Paging Modulator
Compatibility:	MT-3 Series Radio Systems
Modulation:	16K0F3E (FM Analog), and 14K7F1D (FM Data Transmission)
Audio Input:	Balanced 600 Ω (tone or voice)
Digital Input:	Bipolar: RS-232 compatible
Reference Input:	10 MHz, 0.5 to 2.5 V rms, 50 Ω Front Panel SMA
Reference Output:	10 MHz (Modulated), 2.5 V rms, 50 Ω Front Panel SMA

Frequency Stability:	Standard: ± 0.03 ppm from -40°C to $+60^{\circ}\text{C}$ Optional: External High Stability ± 0.002 ppm from -40°C to $+60^{\circ}\text{C}$ (requires WWV or GPS reference source).
Duty Cycle:	Continuous, 100% from -40°C to $+60^{\circ}\text{C}$
Audio Response:	0 Hz to 3.4 kHz
Maximum Deviation:	+/- 50 PPM
Analog / Digital PTT Activation:	Front panel connector and rear motherboard connection
Current Consumption:	+13.8 VDC supply: 600 mA power 200 mA steady state +9.5 VDC supply: 200mA (all options enabled) 80mA (all options disabled) 70mA (LED indicators off).
Operating Temperature Range:	-40°C to $+60^{\circ}\text{C}$
Paging Formats:	4-Level Base Station paging only (Flex) 2-Level Multiple Transmitter paging (POCSAG)
Simulcast Operation:	Supported with the addition of WWV/GPS receiver.
IC Type Approval:	Approved for use with MT-3 VHF Tx additional frequency band approvals to be sought.
FCC Type Acceptance:	Approved for use with MT-3 VHF Tx additional frequency band approvals to be sought.

1.4.2 CTCSS Decoder/Encoder (Option)

Manufacturer:	Communications Specialists Inc.
Model Number:	TS-64
Number of Tones:	64
Frequency Range of Tones:	33.0 to 254.1 Hz
Signal to Noise:	Better than 4 dB SINAD
Decode Time:	150 ms nominal
Fade Time:	350 ms nominal
Squelch Tail Elimination::	160 ms reverse phase burst
Current Consumption:	9 mA

1.4.3 Physical Specifications

Physical Dimensions:	<u>Width:</u> 3.5 cm (1.38")	<u>Height:</u> 12.8 cm (5.05")	<u>Depth:</u> 19 cm (7.5")
Module Weight:	0.4 kg (1 lb.)		
Corrosion Prevention:	Anodized aluminum construction with stainless steel hardware. Selectively applied Conformal coated glass epoxy 4 layer printed circuit boards. Gold plated module connectors.		
Module Design:	Compact Eurostandard modular design. Plug-in module mates with Daniels standard 19" M3 repeater subrack. Interchangeable for test and repair.		
External Connections:	REF Input and Output SMA connectors located on the module's front panel. Motherboard Connections (Audio, Modulation, Power, and Control) are made through a 96 pin, gold plated type C connector on the rear of the module. User connections (Audio, Modulation, and Control) are made through a front panel DB-15 connector as well as through the 96 pin connector on the rear of the module.		

This Page Intentionally Left Blank

2 THEORY OF OPERATION

3 ALIGNMENT PROCEDURE AND INSTALLATION

3.1 General

The CI-PM-3 Paging Modulator is by default configured for stand-alone base station paging, using 2-Level paging data with a binary polarity of 1, and using the on-board +/-0.03 PPM 10 MHz OCXO. Table 4-4 contains a complete list of CI-PM-3 default jumper settings. The CI-PM-3 can also be configured for 4-level signal (base transmitter only) paging, remote paging, link repeater or higher stability operation. Each of these configurations is covered separately in the following sections.

3.2 Repair Notes

Removal and replacement of surface mount components should be performed only in specifically designed surface mount rework and repair stations complete with electrostatic discharge (ESD) protection.

To help prevent damage to the circuit board pads when removing Surface Mount Solder Jumpers, it is recommended that solder braid be used in place of manual vacuum de-soldering tools.

3.3 Recommended Equipment List

Alignment of the CI-PM-3 requires the following test and radio equipment, or its equivalent:

- | | |
|----------------------------------|--|
| • Power Supply: | Regulated +13.8 VDC at 2 A |
| • Oscilloscope / Multi-meter: | Fluke 97 Scopemeter |
| • Current Meter: | Fluke 75 Multi-meter |
| • Radio Communications Test Set: | Marconi Instruments 2955R (W/External Reference) |
| • Sub-rack: | Daniels SR-3 Series 19" Sub-rack |
| • System Monitor: | Daniels SM-3 Series System Monitor |
| • Transmitter Module: | Daniels Enhanced Performance VT-3 / UT-3 Series |
| • Extender Card and Cable: | Daniels EC-96K, 96 Pin Extender Card and Cable |
| • Alignment Tool: | Johanson 8766 |

Note: It is highly recommended that the Radio Communications Test Set be frequency locked to an external 10 MHz reference (WWV or GPS), *especially* if the factory-adjusted frequency settings are to be altered in any way.

3.4 Installation

1. Install the Daniels EC-96 Extender Card in either the far left-hand or the far right-hand slot of the subrack (as viewed from the front). Remove the side covers of the CI-PM-3 Paging Modulator and attach the 96-Pin Extender Cable between it and the Extender Card.
2. Apply +13.8 VDC power to the Subrack. Allow approximately 15 minutes for warm-up.

3.5 Alignment

Refer to Figure 5-1 for the location of the CI-PM-3 module front panel controls.

1. Ensure the CI-PM-3 circuit board jumpers are initialized to their default settings (refer to Table 4-4). Note any differences so that the jumpers can be returned to their former positions.
2. For alignment procedures in this section, set the front panel switches to the following settings, unless otherwise noted:
 - a) SW1 (FREQ REF) set to INT
 - b) SW2 (MODE) set to SETUP
 - c) SW3 (SET MOD) set to 2 LEVEL
 - d) SW4 (SET DEV) set to Data "1" (Top Position)
3. Ensure the Transmitter Audio Processor circuit board jumpers are initialized to their default settings (refer to Tables 4-7 or 4-8).
4. Connect the CI-PM-3 REF OUT connector to the transmitter REFERENCE INPUT connector via a SMA to SMA RF cable.
5. Remove external connections to the DB-15 connector on the CI-PM-3 or the Alarm lines on the back of the subrack.

Do not connect any other input signal/control lines to the CI-PM-3 at this time.

3.6 Frequency (Digital Paging) Adjustment

CI-PM-3 frequency adjustments are factory set. It is strongly recommended that they not be altered. The following procedure applies **only** if field adjustment is required:

1. Set front panel SW1 (FREQ REF) INT and remove shunt jumper JU6-A.
2. Set shunt jumpers JU23-A and JU41-B.
3. Set the transmitter front panel NORM/KEY TX switch to KEY TX.

4. Monitor the Communications Test Set and adjust FREQ ADJ potentiometer R82 for the transmitter operating frequency +/-1 Hz.
5. Set the transmitter front panel NORM/KEY TX switch to NORM and replace JU6-A.

3.7 Reference (Analog Paging) Adjustment

CI-PM-3 Reference frequency adjustment is factory set. It is strongly recommended that they not be altered. The following procedure applies **only** if field adjustment is required.

1. Ensure shunt jumper JU6-A is installed.
2. Set shunt jumpers JU23-A and JU41-A (or not installed).
3. Set the transmitter front panel NORM/KEY TX switch to KEY TX.
4. Monitor the Communications Test Set and adjust REF ADJ potentiometer R24 for the transmitter operating frequency +/-1 Hz.
5. Set the transmitter front panel NORM/KEY TX switch to NORM.

3.8 Test Data Symmetry Adjustment

1. Set the oscilloscope for 1.0 V/Div (vertical) and 0.5 ms/Div (horizontal). Monitor TP10.
2. Set shunt jumpers JU23-A and JU41-B, and set JU36 to bypass.
3. Set SW3 (SET MOD) to 2 LEVEL and SW4 (SET DEV) to the center or “Continuous Bit Stream” position.
4. Adjust R70 (Test Data Symmetry Adjust) for symmetrical positive and negative pulses (i.e. of equal width) as measured at TP10.

3.9 2 And 4 Level Deviation Adjustment

1. Set shunt jumpers JU23-A and JU41-A (or not installed).
2. Monitor TP11 with a voltmeter and adjust R110 for approximately 4 volts at TP11.
3. Monitor the transmitter frequency and deviation on the Communications Test Set and set the transmitter front panel NORM/KEY TX switch to KEY TX.
4. Set shunt jumpers JU23-A and JU41-B.

5. Set SW3 (SET MOD) to 2 LEVEL, and SW4 (SET DEV) to the Data “1” (top) position. For a VHF system adjust R5 (2-LVL +Dev) for +4.8 kHz deviation (4.8 kHz above center frequency). For a UHF system adjust R5 for +4.2 kHz deviation.
6. Change SW4 (SET DEV) to the Data “0” (bottom) position. For a VHF system adjust R6 (2-LVL -Dev) for -4.8 kHz deviation (4.8 kHz below center frequency). For a UHF system adjust R6 for -4.2 kHz deviation.
7. Set shunt jumper JU23-B.
8. Change SW3 (SET MOD) to 4 LEVEL. Adjust R4 (4-LVL -Dev) for -1.6 kHz deviation.
9. Change SW4 (SET DEV) to the Data “1” (top) position. Adjust R3 (4-LVL +Dev) for +1.6 kHz deviation.
10. Set SW3 (SET MOD) to 2 LEVEL. Set SW4 (SET DEV) to the center position. Adjust R23 (BP DEV ADJ) for maximum deviation of +/-4.8 kHz.

3.10 PLL Setup

CI-PM-3 PLL adjustments are factory set. It is **strongly** recommended that they not be altered. The following procedure applies **only** if field adjustment is required:

1. Install Power Enable surface mount jumpers JU37, JU39, JU56 and JU59.
2. Ensure front panel SW1 (FREQ REF) is set to EXT, and shunt jumper JU6-A is removed.
3. Set shunt jumpers JU23-A and JU41-A (or not installed).
4. Connect the 50 Ohm output of a high stability, 10 MHz reference to front panel REF IN SMA connector J3. Ensure the output level of the external reference is between 0.5 to 2.5 V rms.

Steps 5 through 7 apply to Daniels VR-3/150 transmitters.

5. Measure and record the voltage at TP13 with the DMM.
6. Measure the voltage at TP12 with the DMM.
7. Adjust PLL CAL potentiometer R101 until the voltage measured at TP12 matches the voltage measured in step (5) above within ± 0.2 Vdc. Note that when the PLL locks in, the voltage at TP12 will also lock in to within ± 0.2 Vdc of the voltage at TP13. At this point further adjustment of R101 will not change the value unless it is brought out of lock.

Steps 8 and 9 apply to Daniels UHF transmitters.

8. Monitor TP12 with an oscilloscope.
9. Adjust the PLL CAL potentiometer R101 until the voltage measured at TP12 is over 2.7 volts. You should observe a clean DC voltage when the PLL locks in. Any voltage below 2.7 volts results in a badly distorted 10 MHz square wave.
10. Replace shunt jumper JU6-A.

3.11 Data Delay Setup

1. Enable the DATA DELAY option by installing Power Enable surface-mount jumpers JU38 and moving the two DATA DELAY shunt jumpers of JU36 to the DELAY (vertical) position.
2. Set front panel switches SW2 (MODE) to SETUP, SW3 (SET MOD) to 2 LEVEL, and SW4 (SET DEV) to “Continuous Bit Stream” (refer to SW4 DETAIL in Figure 6-1).

To calibrate the positive and negative edge delay:

3. Set the oscilloscope for 1.0 V/Div (vertical) and 0.5 μ s/Div (horizontal). Select channel 1 as trigger input and set Trigger Slope to positive.
4. Monitor the data signal at TP9 on channel 1 of the oscilloscope.
5. Monitor and record the period of the data delay pulse at TP7 on channel 2 of the oscilloscope.
6. Set Trigger Slope to negative.
7. Continue monitoring the data signal at TP9 on channel 1 of the oscilloscope while monitoring the period of the data delay pulse at TP7 on channel 2.
8. Adjust R95, DELAY SYNC, until the period of the data delay pulse measured at TP7 is identical to that measured in step (5) above.

To set the delay resolution (output frequency of Programmable Counter U22):

9. With surface mount jumpers JU31A, JU32A and JU33A installed, monitor the frequency of the signal at TP8.
10. Adjust tuning capacitor C55 for a frequency of 1.0 MHz (+/- 10 Hz) at TP8.

3.12 Simulcast Delay Setup

A typical Simulcast system is depicted in Figure 5-2. To correctly determine the differing propagation path delays to each transmitter in a Simulcast system and compensate for them, signal delays in both the transmission medium and the equipment must be known. For the purposes of this manual, it is assumed that only Daniels MT-3 radio equipment will be utilized at each paging site, and that each radio subrack will be identically configured with CI-PM-3 Paging Modulator modules.

Signal delays from the base transmitter to any paging transmitter are calculated as follows:

$$\text{Delay} = t_{(\text{Link})} + t_{(\text{Eqpt})}$$

Where:	$t_{(\text{Link})}$	=	Propagation delay from Base TX to Paging TX
	$t_{(\text{Eqpt})}$	=	$t_{(\text{RX})} + t_{(\text{PM})} + t_{(\text{TX})}$
	$t_{(\text{RX})}$	=	Delay through Receiver
	$t_{(\text{PM})}$	=	Delay through Paging Modulator
	$t_{(\text{TX})}$	=	Delay through Transmitter
	d	=	Distance

The delay through the equipment at each paging transmitter site, $t_{(\text{Eqpt})}$, will be identical for each link, and can therefore be eliminated from our calculations. As such, the only delay variable(s) of interest will be the distance from the base transmitter to each paging transmitter. Since radio waves propagate at or near the speed of light (3×10^8 m/sec), the delay calculation becomes:

$$\begin{aligned} \text{Delay} &= t_{(\text{Link})} \\ &= d \text{ (km)} \times 3.33 \mu\text{sec} \\ &\quad \text{or} \\ &= d \text{ (mi)} \times 5.37 \mu\text{sec} \end{aligned}$$

For the Simulcast system depicted in Figure 5-2, the signal transmitted by PAGING TX #1 will not be delayed, as this is the furthest site from the BASE TX. However, to ensure identical signal processing characteristics at each site, the DATA DELAY circuitry of the CI-PM-3 at PAGING TX #1 will be enabled, but with zero delay selected. PAGING TX #2 will have its paging signal delayed by a value proportional to the difference in distance between PAGING TX #1 and PAGING TX #2 to the BASE TX. The delay for PAGING TX #2 is therefore calculated as:

$$\begin{aligned} \text{Delay}_{(\text{Link B})} &= (d_{(\text{Link A})} \text{ (km)} - d_{(\text{Link B})} \text{ (km)}) \times 3.33 \mu\text{sec} \\ &\quad \text{or} \\ &= (d_{(\text{Link A})} \text{ (mi)} - d_{(\text{Link B})} \text{ (mi)}) \times 5.37 \mu\text{sec} \end{aligned}$$

The delay calculations for any paging transmitter site in a multiple-transmitter system, with distances measured from the site of interest back to the BASE TX, becomes:

$$\begin{aligned} \text{Delay}_{(\text{Site of Interest})} &= (d_{(\text{Furthest Site})} (\text{km}) - d_{(\text{Site of Interest})} (\text{km})) \times 3.33\mu\text{sec} \\ &\text{or} \\ &= (d_{(\text{Furthest Site})} (\text{mi}) - d_{(\text{Site of Interest})} (\text{mi})) \times 5.37\mu\text{sec} \end{aligned}$$

To set the delay value: Once the required delay has been calculated for a particular paging site, refer to Table 4-3 delay settings:

- a) Locate the DELAY (µsec) value which is closest to the calculated value.
- b) Set surface mount jumpers JU31, JU32, JU33, and JU35 according Table 4-3 in section 4.3.

Data Delay Adjust: To set delay values other than those listed in Table 4-3:

1. Set the oscilloscope for 1.0 V/Div (vertical) and 0.5 µs/Div (horizontal). Select channel 1 as trigger input and set Trigger Slope to positive.
2. Monitor the test data signal at TP9 on channel 1 of the oscilloscope and the output signal at TP5 on channel 2.
3. Adjust the oscilloscope for maximum horizontal display of the distance between the signals' leading edges. Adjust tuning capacitor C55 until the output signal's leading edge on channel 2 is delayed from the input signal's leading edge on channel 1 by the desired delay amount.

Example: To set a delay of 44 µsec:

- i) Set oscilloscope horizontal resolution to 5 µsec/div.
- ii) Install surface mount jumpers JU31B, JU32A, JU33A and JU35E (refer to Table 4-3).
- iii) Monitor TP9 on channel 1 of the oscilloscope. Monitor TP5 on channel 2 of the oscilloscope. Adjust C55 for 8.8 horizontal divisions between the signals' leading edges (8.8×5 µsec = 44 µsec delay).

3.13 Repeater Configuration

The CI-PM-3 modules at both the base transmitter and paging/repeater must be configured individually. Individual setup procedures must also be followed for analog/digital paging and for digital-only paging.

Note: The CI-PM-3 modules must be set for 2-level signal operation only when configured for use in a paging repeater system.

3.13.1 Base Transmitter Site CI-PM-3 Configuration

The setup instructions of sections 3.13.1 through 3.13.3 must be completed prior to commencing setup of the remote paging/repeater site CI-PM-3. Jumper designators separated by a '/' indicates an 'and/or' selection (eg JU19/JU45 means JU19 and/or JU45).

3.13.1.1 Digital-Only Paging

1. Install shunt jumpers JU7-A, JU8-A, JU10-A, JU41-C and JU23-A, JU23-B or JU23-C.
2. Install surface mount jumpers JU22, JU55, and JU20/JU21.
3. Remove surface mount jumpers JU19, JU28, JU29, JU30, JU34, JU43, JU44, JU45, JU52, JU53 and JU54.

3.13.1.2 Analog/Digital Paging

Ensure the TS-64 CTCSS Module, MOD1, is installed. Refer to section 3.13.3 for TS-64 CTCSS Module Configuration and settings for jumpers JU52, JU53 and JU54.

1. Install shunt jumpers JU7-A, JU8-A, JU10-B, JU41-A and JU23-A, JU23-B or JU23-C.
2. Install surface mount jumper JU20/JU21, JU22 and JU55.
3. Remove surface mount jumpers JU19, JU28, JU29, JU30, JU34, JU43, JU44, JU45 and JU51.

3.13.2 Repeater Site CI-PM-3 Configuration

At the remote paging/repeater site, the digital paging signal is received and discriminated by the receiver, regenerated (reshaped) by the CI-PM-3, and re-transmitted through the normal CI-PM-3 data signal path. Analog paging signals are routed from the receiver, through the CI-PM-3, then directly to the transmitter.

3.13.2.1 Digital-Only Repeater

1. Install shunt jumpers JU41-C and JU23-A, JU23-B or JU23-C.
2. Install surface mount jumpers JU7-B, JU8-B, JU10-A, JU19/JU45, JU20/JU21, JU22, JU29/JU43, and JU55.
3. Remove surface mount jumpers JU34, JU51, JU52, JU53 and JU54.

3.13.2.2 Analog/Digital Repeater

Ensure the TS-64 CTCSS Module, MOD1, is installed. Refer to section 3.13.3 for TS-64 CTCSS Module Configuration and settings for jumpers JU52, JU53 and JU54.

1. Install shunt jumpers JU7-B, JU8-B, JU10-B, JU41-A and JU23-A, JU23-B or JU23-C.
2. Install surface mount jumpers JU19/JU45, JU20/JU21, JU22, JU28, JU29/JU43, JU30/JU44 and JU55.
3. Remove surface mount jumpers JU34 and JU51.

3.13.3 TS-64 Configuration

1. Ensure POLARITY jumper JP7 is installed.
2. For normal operation (i.e. receiver audio is muted until a CTCSS coded transmission is received):
 - a) Ensure TS-64 jumper JP11 is removed.
 - b) Ground the TS-64 Hang-up Input:
 - i) Install jumper JU52, or
 - ii) Remove jumper JU52, install jumper JU53 and ground CTCSS HU/BUSY input J1 Pin 11.

3. To place the TS-64 in monitor mode (i.e. over-ride the decoder and unmute the receiver audio for channel monitoring):
 - a) Ensure TS-64 jumper JP11 is removed.
 - b) Ensure the TS-64 Hang-up Input is floating or above ground potential:
 - i) Remove jumpers JU52 and JU53, or
 - ii) Remove jumper JU52, install jumper JU53, and leave CTCSS HU/BUSY input J1 Pin 11 floating.
4. To disable paging transmission while the channel is busy:
 - a) Install TS-64 jumper JP11.
 - b) Remove jumper JU52, install jumpers JU53 and JU54.

4 CONNECTOR PIN FUNCTIONS AND JUMPER FUNCTIONS

4.1 Data / Control Port (Connector J1) Pin Functions

Table 4-1 Data / Control Port (Connector J1) Pin Functions

PIN	NAME	FUNCTION
1	2-Lvl Data	2 Level RS-232 Data input.
2	4-Lvl Data	4 Level RS-232 Data input.
3	Ext Clock	External Clock for 4 Level signal synchronization.
4	2-Lvl/4-Lvl Select	2 Level / 4 Level select. Low = 2 Level, High = 4 Level.
5	A/D Mode Select	Analog / Digital Mode select. Low = Digital, High = Analog.
6	Discr O/P	Discriminator Output from Receiver.
7	PTT	Push To Talk.
8	Ground	Ground.
9	Balanced Audio I/P 1	Balanced Audio Input 1. Routed directly to Transmitter.
10	Balanced Audio I/P 2	Balanced Audio Input 2. Routed directly to Transmitter.
11	Data Out	Regenerated digital data from receiver.
12	HU/Busy	CTCSS Hang Up / Busy signal from optional CTCSS module.
13	No Connection	-
14	No Connection	-
15	No Connection	-

4.2 Motherboard Interface (Connector P1) Pin Functions

Table 4-2 Motherboard Interface Connector P1 Pin Functions

Note: **Bolded** entries are utilized by CI-PM-3

PIN	NAME	FUNCTION
C1	IMC1	Inter-module Communications Line No. 1
B1	5W RX AUDIO	5W RX A/RX B Audio From System Monitor
A1	5W RX AUDIO	5W RX A/RX B Audio From System Monitor
C2	TX A AUDIO CNTL	TX A Audio Control
B2	13.8V	13.8V from M3 Motherboard J8 (Unregulated)
A2	13.8V	13.8V from M3 Motherboard J8 (Unregulated)
C3	IMC2	Inter-module Communications Line No. 2
B3	RX A AMPD AUDIO	RX A Amplified Audio Output
A3	RX B AMPD AUDIO	RX B Amplified Audio Output
C4	TX B AUDIO CNTL	TX B Audio Control
B4	9.5V	Regulated +9.5V from System Monitor
A4	9.5V	Regulated +9.5V from System Monitor
C5	IMC3	Inter-module Communications Line No. 3
B5	RX A 9.5V	RX A Current Sense Output Line (Supply)
A5	RX B 9.5V	RX B Current Sense Output Line (Supply)
C6	ALARM 1	Inter-module Alarm Line No. 1.
B6	TX A PTT	Transmitter A Press To Talk input.
A6	TX B PTT	Transmitter B Press To Talk input.
C7	ALARM 2	Inter-module Alarm Line No. 2.
B7	RX A 9.5V MON	RX A Current Sense Output Line (Module)
A7	RX B 9.5V MON	RX B Current Sense Output Line (Module)
C8	ALARM 3	Inter-module Alarm Line No. 3
B8	RX A COR	RX A Carrier Operated Relay Output
A8	RX B COR	RX B Carrier Operated Relay Output

PIN	NAME	FUNCTION
C9	ALARM 4	Inter-module Alarm Line No. 4
B9	TX A STANDBY	TX A Audio Standby
A9	TX B STANDBY	TX B Audio Standby
C10	RX A SQL OVERRIDE	RX A Squelch Disable Input
B10	RX A DISC O/P	RX A Discriminator Output
A10	TX A PTT OUT	TX A Microphone Press To Talk Output
C11	ALARM 5	Inter-module Alarm Line No. 5
B11	SPARE 5	Inter-module Spare Line No. 5
A11	SPARE 6	Inter-module Spare Line No. 6
C12	RX A SQL FLAT	RX A Squelched, Flat Audio Output
B12	RX A ISO COR A	RX A Isolated Carrier Operated Relay, Side A O/P
A12	RX A ISO COR K	RX A Isolated Carrier Operated Relay, Side K O/P
C13	ALARM 6	Inter-module Alarm Line No. 6
B13	RX A DISC L/P O/P	RX A Discriminator Low-Pass Audio Output
A13	RX B DISC L/P O/P	RX B Discriminator Low-Pass Audio Output
C14	RX B SQL DE-EMP	RX B Squelched, De-Emphasized Audio Output
B14	SPARE 3	Inter-module Spare Line No. 3
A14	SPARE 4	Inter-module Spare Line No. 4
C15	ALARM 7	Inter-module Alarm Line No. 7
B15	RX A SIG STREN	RX A Signal Strength Indicator Output
A15	RX B SIG STREN	RX B Signal Strength Indicator Output
C16	TX B BAL I/P 1	TX B Balanced Audio Input, Side 1
B16	TX B SUBT I/P 1	TX B Subtone Audio Input No. 1
A16	TX B PTT OUT	TX B Microphone Press To Talk Output
C17	ALARM 8	Inter-module Alarm Line No. 8
B17	TX A VSWR FWD	TX A VSWR Forward Level Indicator Output
A17	TX B VSWR FWD	TX B VSWR Forward Level Indicator Output
C18	TX A BAL I/P 1	TX B Balanced Audio Input, Side 1
B18	TX A BAL I/P 2	TX B Balanced Audio Input, Side 2
A18	TX B BAL I/P 2	TX B Balanced Audio Input, Side 2
C19	SPARE 1	Inter-module Spare Line No. 1
B19	TX A VSWR REV	TX A VSWR Reverse Level Indicator Output
A19	TX B VSWR REV	TX B VSWR Reverse Level Indicator Output
C20	SPARE 2	Inter-module Spare Line No. 2
B20	TX A DIR MOD	TX A Direct Modulation Input
A20	TX B DIR MOD	TX B Direct Modulation Input
C21	TX A CSEL D0	TX A Channel Select Line No. D0
B21	TX A CSEL D1	TX A Channel Select Line No. D1
A21	TX A CSEL D2	TX A Channel Select Line No. D2
C22	TX A SUBT I/P 1	TX A Subtone Audio Input No. 1
B22	RX A MUTE	RX A Mute Input
A22	RX A SQL DE-EMP	RX A Squelched, De-Emphasized Audio Output
C23	TX A CSEL D3	TX A Channel Select Line No. D3
B23	RX A CSEL D0	RX A Channel Select Line No. D0
A23	RX A CSEL D1	RX A Channel Select Line No. D1
C24	TX A SUBT I/P 2	TX A Subtone Audio Input No. 2
B24	RX A BAL O/P 1	RX A Balanced Audio Output, Side 1
A24	RX A BAL O/P 2	RX A Balanced Audio Output, Side 2
C25	RX A CSEL D2	RX A Channel Select Line No. D2
B25	RX A CSEL D3	RX A Channel Select Line No. D3
A25	TX B CSEL D0	TX B Channel Select Line No. D0
C26	TX B SUBT I/P 2	TX B Subtone Audio Input No. 2
B26	RX B SQL OVERRIDE	RX B Squelch Disable Input
A26	RX B MUTE	RX B Mute Input

PIN	NAME	FUNCTION
C27	TX B CSEL D1	TX B Channel Select Line No. D1
B27	TX B CSEL D2	TX B Channel Select Line No. D2
A27	TX B CSEL D3	TX B Channel Select Line No. D3
C28	RX B DISC O/P	RX B Discriminator Audio Output
B28	RX B ISO COR K	RX B Isolated Carrier Operated Relay, Side K O/P
A28	RX B ISO COR A	RX B Isolated Carrier Operated Relay, Side A O/P
C29	RX B CSEL D0	RX B Channel Select Line No. D0
B29	RX B CSEL D1	RX B Channel Select Line No. D1
A29	RX B CSEL D2	RX B Channel Select Line No. D2
C30	RX B BAL O/P 1	RX B Balanced Audio Output, Side 1
B30	RX B BAL O/P 2	RX B Balanced Audio Output, Side 2
A30	RX B SQL FLAT	RX B Squelched, Flat Audio Output
C31	RX B CSEL D3	RX B Channel Select Line No. D3
B31	RX A PRIORITY COR	RX A Priority COR (not affected by Mute)

4.3 CI-PM-3 Data Delay Jumper Settings

Table 4-3 Delay Settings

JUMPER SETTINGS				DELAY	DISTANCE	DISTANCE
JU33	JU32	JU31	JU35	(μ Sec)	(km)	(mi)
A	A	A	A	4	1.20	0.75
A	A	B	A	8	2.40	1.49
A	A	A	C	12	3.60	2.24
A	B	A	A	16	4.80	2.98
A	A	A	E	20	6.00	3.73
A	B	B	C	24	7.20	4.47
A	B	B	A	32	9.60	5.97
A	A	B	E	40	12.00	7.46
A	B	A	C	48	14.40	8.95
B	A	A	A	64	19.20	11.93
A	B	A	E	80	24.00	14.91
A	B	B	C	96	28.80	17.90
B	A	B	A	128	38.40	23.86
A	B	B	E	160	48.00	29.83
B	A	A	C	192	57.60	35.79
B	B	A	A	256	76.80	47.72
B	A	A	E	320	96.00	59.65
B	A	B	C	384	115.20	71.59
B	B	A	B	512	153.60	95.45
B	A	B	E	640	192.00	119.31
B	B	A	C	768	230.40	143.17
B	B	A	D	1024	307.20	190.89
B	B	A	E	1280	384.00	238.62
B	B	A	F	1536	460.80	286.34

4.4 CI-PM-3 Circuit Board Jumpers

Table 4-4 CI-PM-3 Default Jumper Settings

REF. DESIG.	DESCRIPTION	JUMPER TYPE	DEFAULT POSITION
JU1	2-LVL Polarity Select (A = Inverted ; B = Normal)	Shunt	B
JU2	4-LVL Polarity Select (A = Normal; B = Inverted)	Shunt	A
JU3	RX A Balanced O/P 1 Enable	SM Solder	Not Installed
JU4	RX A Balanced O/P 2 Enable	SM Solder	Not Installed
JU5	XO Polarity Select (A = Normal; B = Inverted)	Shunt	B
JU6	XO Select (A=OCXO; B=VCXO)	Shunt	A
JU7	Data Regeneration (A = Disable; B = Enable)	SM Solder	A
JU8	Data Input (A = Data/Ctrl Port; B=RX A Regenerated Data)	SM Solder	A
JU9	Discriminator O/P To Front Panel J1 Enable	SM Solder	Not Installed
JU10	Repeater CTCSS Enable (A = Disable; B = Enable)	SM Solder	A
JU11	TX A Direct Modulation Enable	SM Solder	Installed
JU12	TX B Direct Modulation Enable	SM Solder	Not Installed
JU13	TX A Subtone I/P 2 Enable	SM Solder	Not Installed
JU14	TX B Subtone I/P 2 Enable	SM Solder	Not Installed
JU15	TX A Balanced I/P 1 Enable	SM Solder	Installed
JU16	TX B Balanced I/P 1 Enable	SM Solder	Not Installed
JU17	TX A Audio Control Enable	SM Solder	Installed
JU18	TX B Audio Control Enable	SM Solder	Not Installed
JU19	RX A COR Enable	SM Solder	Not Installed
JU20	TX A PTT Enable	SM Solder	Installed
JU21	TX B PTT Enable	SM Solder	Not Installed
JU22	Repeater PTT Enable	SM Solder	Not Installed
JU23	Level Select (A=2/4-LVL; B=4-LVL)	Shunt	A
JU24	TX A Balanced I/P 2 Enable	SM Solder	Installed
JU25	TX B Balanced I/P 2 Enable	SM Solder	Not Installed
JU26	Alarm 7 To TX A and B Balanced O/P 1 Enable	SM Solder	Installed
JU27	Alarm 5 To TX A and B Balanced O/P 2 Enable	SM Solder	Installed
JU28	CTCSS RX A Mute Bypass	SM Solder	Not Installed
JU29	RX A Discriminator Output Enable	SM Solder	Not Installed
JU30	RX A Mute Enable	SM Solder	Not Installed
JU31	Data Delay Selection (Refer to Table 4-3)	SM Solder	A
JU32	Data Delay Selection (Refer to Table 4-3)	SM Solder	A
JU33	Data Delay Selection (Refer to Table 4-3)	SM Solder	A
JU34	CTCSS PTT Bypass	SM Solder	Installed
JU35	Data Delay Selection (A - F, Refer to Table 4-3)	SM Solder	A
JU36	Data Delay/By-Pass	Shunt	Bypass
JU37	Switched 8.0 Volts For PLL I/O Circuitry	SM Solder	Not Installed
JU38	Switched 8.0 Volts For Data Delay Circuitry	SM Solder	Not Installed
JU39	Switched 5.0 Volts For PLL I/O Circuitry	SM Solder	Not Installed
JU40	Switched 5.0 Volts For Regenerated PTT and Data Delay Circuitry	SM Solder	Not Installed
JU41	Analog/Digital Mode Over-ride	Shunt	A
JU42	Low Frequency Deviation Enable	SM Solder	Not Installed
JU43	RX B Discriminator O/P Enable	SM Solder	Not Installed
JU44	RX B Mute Enable	SM Solder	Not Installed
JU45	RX B COR Enable	SM Solder	Not Installed
JU46	RX B Balanced O/P 1 Enable	SM Solder	Not Installed
JU47	RX B Balanced O/P 2 Enable	SM Solder	Not Installed
JU48	External Clock Enable (A = Disable; B = Enable)	Shunt	A
JU49	Switched 5.0 Volts For 2-LVL / 4-LVL Switching Circuitry	SM Solder	Installed
JU50	RS-232 Data Out Enable	SM Solder	Not Installed

REF. DESIG.	DESCRIPTION	JUMPER TYPE	DEFAULT POSITION
JU51	Repeater Digital-Only PTT Enable	SM Solder	Installed
JU52	TS-64 Hang-up RX Mute	SM Solder	Not Installed
JU53	TS-64 Busy Input Enable	SM Solder	Not Installed
JU54	TS-64 Busy Input Connect to COR	SM Solder	Not Installed
JU55	TS-64 Repeater PTT Enable (Analog/Digital only)	SM Solder	Not Installed
JU56	Switched 9.5 Volts For Reference Input Circuitry	SM Solder	Not Installed
JU57	U18 (14174 IC) enable	SM Solder	Not Installed
JU58	Data regeneration	SM Solder	Not Installed
JU59	PLL calibration reference	SM Solder	Not Installed
JU60	U4 or U4A select	SM Solder	Not Installed

4.5 TS-64 MOD1 Jumper Settings - (If installed)

Table 4-5 CTCSS Jumper Settings

REF. DESIG.	DESCRIPTION	DEFAULT POSITION
JP1-JP6	CTCSS Tone Frequency Select	*
JP7	RX Audio Mute Polarity (Installed: Mute = Open, Not Installed: Mute = Ground)	Installed
JP8-JP10	TX Time-Out-Timer Interval Select	*
JP11	Hang-Up/Busy-Input Configure (Installed = Busy-Input, Not Installed = Hang-Up Input)	Not Installed

Note: Refer to TS-64 Instruction Sheet for configuration details.

4.6 4-Level Modulation Bit Pattern

Table 4-6 4-Level Modulation Bit Pattern

J1-PIN1 (BIT 0)	J1-PIN2 (BIT 1)	DEVIATION SETTING
0	0	- 4800 Hz
0	1	- 1600 Hz
1	1	+ 1600 Hz
1	0	+ 4800 Hz

4.7 Receiver IF / Audio PCB Jumper Settings

Table 4-9 Receiver IF / Audio PCB Jumper Settings

JUMPER	POSITION
JU5	Short
JU25	Short
JU37	Open

Note: All other jumper settings as per the factory defaults.

4.8 Transmitter Audio Processor Jumper Settings

Figure 4-1 Transmitter Audio Processor V1.6 Jumper Settings

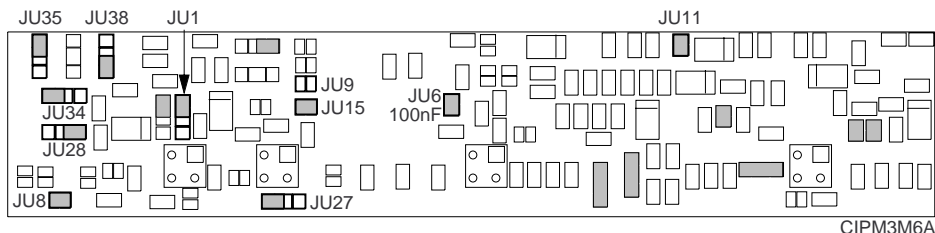

Table 4-7 Transmitter Audio Processor V1.6 Jumper Settings

JUMPER	POSITION	JUMPER	POSITION
JU1	Y	JU15	Open
JU6 (VHF)	Replaced with 100nF	JU27	Y
JU6 (UHF)	Short	JU28	Y
JU8	Short	JU34	Y
JU9	Open	JU35	Y
JU11	Open	JU38	Y
JU10	Short		

Note: All other jumper settings as per the factory defaults.

Figure 4-2 Transmitter Audio Processor V1.8 Jumper Settings

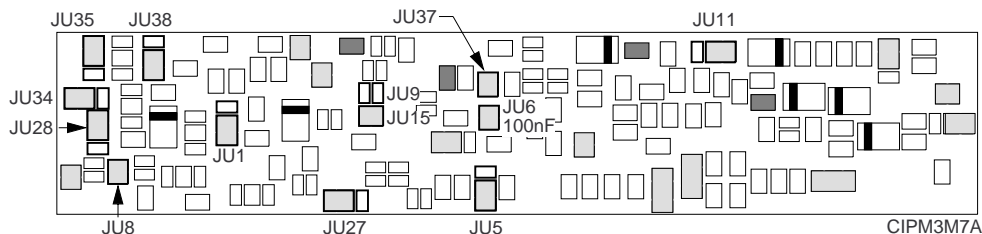

Table 4-8 Transmitter Audio Processor V1.8 Jumper Settings

Jumper	Balanced I/P	Subtone I/P 1 / 2	Description
JU1	OUT	OUT	Direct Modulation Circuits Power Source Select
JU2	OUT	OUT	MT-2 Deviation Enable (MT-2 Transmitters)
JU3	OUT	OUT	Microphone Pre-amplifier Flat Response
JU4	OUT	IN	Subtone Input 2 Audio Path Select
JU5	OUT	OUT / Y	Auxiliary Input Enable (DC Or AC Coupled)
JU6	IN(UHF)	IN(UHF)	Processed Audio Path Enable (Limited And Filtered). Replace with a 100nF capacitor for VHF
JU7	OUT	OUT	Unprocessed Auxiliary Audio Path Enable (Unfiltered)
JU8	IN	IN	Audio Output DC Coupled
JU9	OUT	OUT	Balanced Input Pre-emphasis Response Enable
JU10	IN	OUT	Balanced Input Flat Audio Response Enable

JU11	Y	OUT	Balanced Input To Auxiliary Audio Circuit Enable
JU12	OUT	OUT	Tone/Digital Input To Auxiliary Audio Circuit Enable
JU13	OUT	OUT / IN	Direct Modulation Input To Auxiliary Audio Circuit Enable
JU14	OUT	OUT	Auxiliary Input Pre-emphasis Response Enable
JU15	OUT	OUT / IN	Auxiliary Input Flat Audio Response Enable
JU16	OUT	IN / OUT	Subtone Input 1 Audio Path Select
JU17	OUT	OUT	MT-2 Temperature Compensation Bypass
JU18	OUT	OUT	Continuous Data Mode Selection
JU19	X	X	Audio Switches Power Source Select (X=Continuous, Y=Switched)
JU20	Y	Y	Q2 Power Source Select (Y=Continuous, X=Switched)
JU21	Y	Y	Bilateral Switch Power Source Select (Y=Continuous, X=Switched)
JU22	X	X	Audio Output To Splatter Filter
JU23	OUT	OUT / IN	Direct Modulation Input To Subtone 2 Enable
JU24	OUT	OUT	Splatter Filter Response Select
JU25	OUT	OUT	Splatter Filter Response Select
JU26	OUT	OUT	Splatter Filter Response Select
JU27	Y	Y	Direct Modulation Input Audio Path Select
JU28	Y	Y	Amplified Direct Modulation Bypass
JU29	OUT	OUT	Amplified Direct Modulation Input DC Coupled Enable
JU30	OUT	OUT	Amplified Direct Modulation Audio Path Select
JU31	OUT	OUT	Audio Output AC-Coupled (MT-3 Synthesized Transmitters)
JU32	OUT	OUT	Audio Output AC-Coupled (MT-3 Crystal Transmitters)
JU33	OUT	OUT	Audio Output AC-Coupled
JU34	Y	Y	Audio Output From Direct Modulation Circuits Select
JU35	OUT	OUT	Direct Modulation Output Source Select
JU36	Y	OUT	AGC Preamplifier Power Source Select (Y=Continuous, X=Switched)
JU37	OUT	OUT	Direct Modulation Output Enable
JU38	OUT	OUT / X	Subtone 2, DC Coupled, To Direct Modulation Output Select
JU39	OUT	OUT	Direct Modulation Low Input Impedance Enable
JU40	OUT	OUT	Microphone Preamplifier Power Enable
JU41			<i>Not Used</i>
JU42	OUT	OUT	Processed Audio Path To Direct Modulation Output
JU43	OUT	OUT	Bilateral Switch U9 Bypass Enable

Figure 4-3

Transmitter Audio Processor V2.3 Jumper Settings

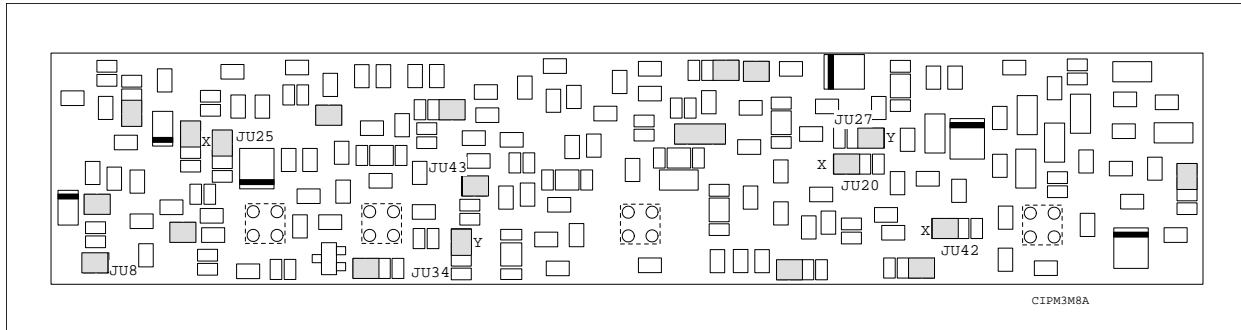
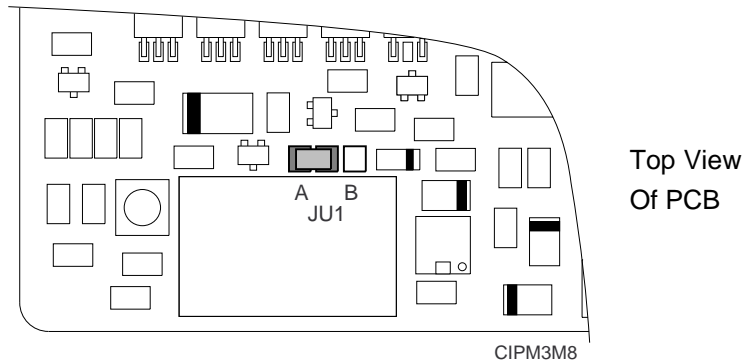

Table 4-9 Transmitter Audio Processor V2.3 Jumper Settings

JUMPER	POSITION	DESCRIPTION
JU8	Short	Audio Output DC couple
JU20	X	Direct modulation input buffer (X enabled, Y bypass)
JU21	Y	Transmit audio control
JU25	X	Wide/Narrow Band Switched Select (X wide)
JU27	Y	Direct Modulation Input Offset Output (Y enabled, X Bypass)
JU34	Y	Audio Routing (Y enabled , X dual port)
JU42	X	Modulation input bias select (X no offset, Y offset adjust)
JU43	Short	Modulation input Direct (Short) / Cap Couple (Open)

4.9 Transmitter Synthesizer Jumper Settings

Figure 4-3 VHF and (400 MHz) UHF Synthesizer Analog PCB Jumper Settings



Jumper JU1 must be installed in the 'A' position to enable the external reference option.

Figure 4-4 VHF and (400 MHz) UHF Synthesizer Digital PCB Jumper Settings

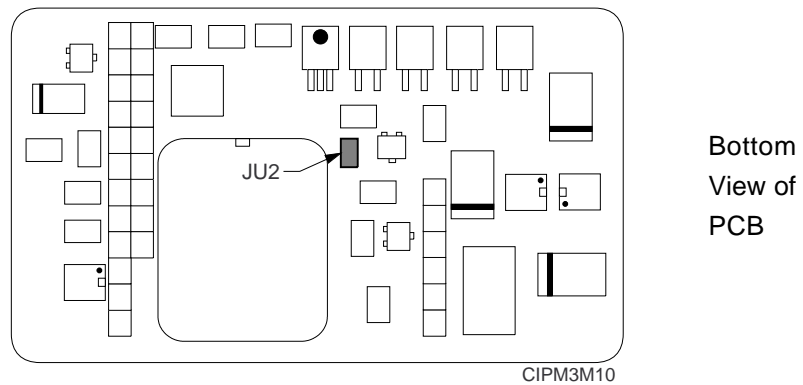

Jumper JU2 must be installed to enable the 10MHz reference option.

Figure 4-5 800MHz and 900MHz Transmitter Synthesizer Jumper Settings

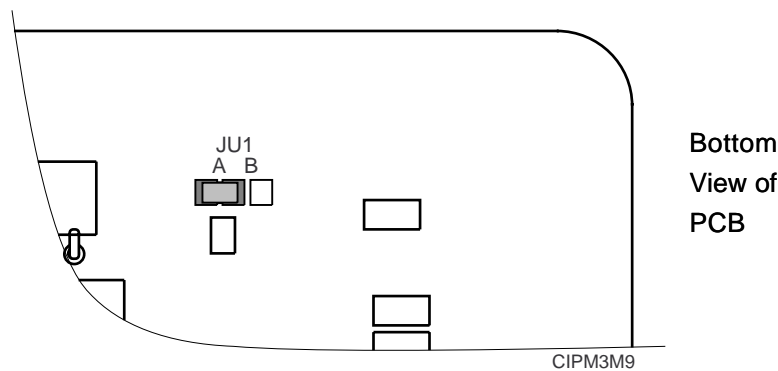

Jumper JU1 must be installed in the 'A' position to enable the external reference option.

4.10 CI-PM-3 Test Points

Table 4-10 CI-PM-3 Test Points

TEST POINT	DESCRIPTION
TP1	+8 Vdc Supply
TP2	+4 Vdc Supply
TP3	+5 Vdc Supply
TP4	Analog / Digital Mode (High = Digital, Low = Analog)
TP5	2 Level Data (TTL)
TP6	OCXO 9.5 Vdc Supply
TP7	Positive and Negative Edge Integrator Output
TP8	Data Delay Programmable Counter Output.
TP9	Input to Data Delay Circuitry
TP10	2 Level Data
TP11	Level Adjusted Paging Signal
TP12	OCXO Reference Adjust (nominally 2.5 Vdc)
TP13	PLL Correction Voltage
TP14	Tx A/B Direct Modulation Output
TP15	13.8 Vdc Supply Input (from Subrack)
TP16	9.5 VDC Supply Input (from Subrack)
TP17	Low Pass Filter Output

5 ILLUSTRATIONS AND SCHEMATIC DIAGRAMS

5.1 CI-PM-3 Front Panel Controls

6 PARTS LISTS

6.1 CI-PM-3 Electrical Parts List

7 REVISION HISTORY

Issue	Issued	Revised	Details
3	Nov 99	N/A	All prototype updates incorporated in this issue. All previous revision history in preliminary issue 3 (Pre3).
		Jan 02	New CI-PM-3 version to accommodate multiple footprints for U4 (AD9901), and incorporate changes to the reference input circuit (MMIC removed).
4	Jan 02		New Issue, incorporates all changes since release of Issue 3.
4 A		Dec 02	Correct component layout (bottom CIPM3M4E) <ul style="list-style-type: none">- TP14 & TP15 locations corrected- JU56 designation removed



MT-3 RADIO SYSTEMS

UHF SYNTHESIZED TRANSMITTER INSTRUCTION MANUAL UT-3/400 406 - 512 MHz

Covers models:

UT-3/420-SNC2, UT-3/420-SWC2, UT-3/420-SNC8, UT-3/420-SWC8,
UT-3/460-SNC2, UT-3/460-SWC2, UT-3/460-SNC8, UT-3/460-SWC8,
UT-3/480-SNC2, UT-3/480-SWC2, UT-3/480-SNC8, UT-3/480-SWC8,
UT-3/500-SNC2, UT-3/500-SWC2, UT-3/500-SNC8, UT-3/500-SWC8,

Copyright © 1998 Daniels Electronics Ltd. All rights reserved. No part of this publication may be reproduced, stored in a retrieval system or transmitted in any form or by any means, electronic, mechanical, photocopying, recording or otherwise, without the prior written consent of Daniels Electronics Ltd.

DE™ is a registered trademark of Daniels Electronic Ltd. registered in the United States Patent and Trademark Office.

Issue:	4	Previous Issue:	3	
Issue Date:	December 98	Previous Issue Date:	August 98	Daniels Electronics Ltd.
Printing Date:	December 98			Victoria, BC
Part No.:	IM23-UT3400			PRINTED IN CANADA

Reviewed By:

Quality Assurance:

Larry Freeman

Name

Signature

Date

NOTE:

The user's authority to operate this equipment could be revoked through any changes or modifications not expressly approved by Daniels Electronics Ltd.

The design of this equipment is subject to change due to continuous development. This equipment may incorporate minor changes in detail from the information contained in this manual.

TABLE OF CONTENTS

	Page
1	GENERAL..... 1-1
1.1	Introduction..... 1-1
1.2	Manual Organization..... 1-1
1.3	UT-3 406 - 512 MHz Transmitter Family Models..... 1-2
1.4	Performance Specifications..... 1-3
1.4.1	General..... 1-3
1.4.2	Audio Specifications 1-4
1.4.3	Physical Specifications..... 1-5
2	SYSTEM OVERVIEW..... 2-1
2.1	Transmitter Operation 2-1
2.2	Frequency Selection..... 2-3
2.2.1	Synthesizer Transmitter 2-3
2.3	Transmitter Assembly and Adjustment..... 2-3
2.3.1	Complete Transmitter Alignment..... 2-3
2.3.2	Frequency Change 2-4
2.3.3	Output Power Adjustment..... 2-5
2.3.4	Deviation Setting..... 2-5
2.3.5	Setting RF Alarm Thresholds..... 2-5
2.4	Recommended Test Equipment List..... 2-6
2.5	Repair Note..... 2-6
2.6	Printed Circuitboard Numbering Convention..... 2-6
3	ILLUSTRATIONS 3-1
3.1	MT-3 Transmitter Front Panel 3-1
3.2	MT-3 Transmitter Case - Exploded View..... 3-2
4	PARTS LIST 4-1
5	REVISION HISTORY 5-1

MODULE MANUALS

Transmitter Main Board Instruction Manual	IM20-MT3TXMN
UHF Amplifier Instruction Manual UT-3 406 - 512 MHz	IM23-UT3400AMP
Enhanced Synthesizer Instruction Manual OS(R/T)-3A/H 29-470 MHz ..	IM10-OS3AH
UHF Transmitter Channel Designation Table	IM23-UT3400CT

1 GENERAL

1.1 Introduction

The UT-3 406 - 512 MHz Transmitter is a synthesized FM transmitter capable of operating in 12.5 kHz or 25 kHz channels. The transmitter operates continuous duty in one of four frequency bands: 406 to 430 MHz, 450 to 470 MHz, 470 to 490 MHz or 490 to 512 MHz and its output power is continuously adjustable from 0.5 TO 2.0 or 2.0 to 8.0 Watts. The transmitter is not to be operated within the 406 to 406.1 MHz frequency band, unless specifically authorized by COSPAS/SARSAT through the Federal Communications Commission and/or Industry Canada. A modular design allows each of the transmitter's modules; MT-3 Transmitter Board, MT-3 Audio Processor, UT-3/400 Amplifier, and OS-3H400 Synthesizer Module to be individually assembled and tested. This facilitates construction, tuning, maintenance as well as troubleshooting procedures. The synthesizer module can be programmed to have up to 16 channels exclusive to one frequency band.

The UT-3 406 - 512 MHz Transmitter is designed to interface with Daniels Electronics' MT-3 Repeater System while maintaining MT-2 System compatibility. Both repeater systems are characterized by dependable, low maintenance performance under the most severe environmental conditions.

1.2 Manual Organization

The organization of this manual reflects the modular makeup of the UT-3 product line. Each module is fully described within its respective submanual, all of which are contained within this document. In general, each submanual contains:

1. A functional description and specification summary,
2. A detailed technical description (Theory of Operation) and
3. Assembly, setup and alignment procedures relevant to that particular module.

The module manuals are as follows:

Note: material presented in a given "submanual" may include information related to other module versions not directly applicable to the UT-3 406 - 512 MHz Transmitter family (eg, the OS-3H Synthesizer Instruction Manual covers models from 29 MHz to 512 MHz).

UHF Transmitter Instruction Manual UT-3 406 - 512 MHz: This manual provides an overview of the complete transmitter, manual organization and assembly in terms of the other modules.

MT-3 Transmitter Main Board Instruction Manual: This manual pertains to the audio processor module, transmitter Main Board and Front Panel Board. Most of the user selectable options are accessed within the Transmitter Main Board module, including channel selection. Since all external connections (including power and signal lines) are made to the Transmitter Main Board, most of the material pertaining to transmitter operation and installation is found here.

UHF Amplifier Instruction Manual UT-3 406 - 512 MHz : The amplifier module provides the final stages of RF power amplification and harmonic filtering for the transmitter. This manual is intended primarily as a reference since the amplifier module is adjusted at the factory.

Enhanced Synthesizer Instruction Manual OS(R/T)-3(A/H) 132 - 470 MHz: This manual pertains to the enhanced synthesizer module.

UHF Transmitter Channel Designation Table UT-3 406 - 512 MHz: This document relates the operating frequency to the transmitter channel number (see section 2.1).

1.3 UT-3 406 - 512 MHz Transmitter Family Models

There are 16 distinct models in the UT-3/400 Transmitter family each with different bands of operation, channel spacing and/or power outputs. The 16 models are as follows:

- UT-3/420-SN02 - synthesized, 406-430 MHz band, 12.5 kHz channels, 0.5-2.0 Watt
- UT-3/420-SN08 - synthesized, 406-430 MHz band, 12.5 kHz channels, 2.0-8.0 Watt
- UT-3/420-SW02 - synthesized, 406-430 MHz band, 25 kHz channels, 0.5-2.0 Watt
- UT-3/420-SW08 - synthesized, 406-430 MHz band, 25 kHz channels, 2.0-8.0 Watt

- UT-3/460-SN02 - synthesized, 450-470 MHz band, 12.5 kHz channels, 0.5-2.0 Watt
- UT-3/460-SN08 - synthesized, 450-470 MHz band, 12.5 kHz channels, 2.0-8.0 Watt
- UT-3/460-SW02 - synthesized, 450-470 MHz band, 25 kHz channels, 0.5-2.0 Watt
- UT-3/460-SW08 - synthesized, 450-470 MHz band, 25 kHz channels, 2.0-8.0 Watt

- UT-3/480-SN02 - synthesized, 470-490 MHz band, 12.5 kHz channels, 0.5-2.0 Watt
- UT-3/480-SN08 - synthesized, 470-490 MHz band, 12.5 kHz channels, 2.0-8.0 Watt
- UT-3/480-SW02 - synthesized, 470-490 MHz band, 25 kHz channels, 0.5-2.0 Watt
- UT-3/480-SW08 - synthesized, 470-490 MHz band, 25 kHz channels, 2.0-8.0 Watt

- UT-3/500-SN02 - synthesized, 490-512 MHz band, 12.5 kHz channels, 0.5-2.0 Watt
- UT-3/500-SN08 - synthesized, 490-512 MHz band, 12.5 kHz channels, 2.0-8.0 Watt
- UT-3/500-SW02 - synthesized, 490-512 MHz band, 25 kHz channels, 0.5-2.0 Watt
- UT-3/500-SW08 - synthesized, 490-512 MHz band, 25 kHz channels, 2.0-8.0 Watt

The transmitters' band of operation is determined by select components in the synthesizer module and the channel width is determined by the roll-off of the splatter filter on the MT-3 Audio Processor.

1.4 Performance Specifications

1.4.1 General

The following is a general set of specifications for the generic UT-3/400 transmitter. Additional specifications, specific to individual modules may be found in their respective submanuals.

Type:	MT-3 Series Transmitter.
Family:	UT-3 406 - 512 MHz.
Compatibility:	MT-2 Series and MT-3 Series Radio Systems.
Frequency Range:	406 to 512 MHz (406 to 406.1 MHz unavailable, see note below).
RF Power Output:	Continuously Adjustable: 0.5 to 2.0 W or 2.0 to 8.0 W.
Modulation:	11K0F3E or 16K0F3E (Frequency Modulation).
System Impedance:	50 Ω ; Type N connector.
Duty Cycle:	100%; Continuous operation from -40°C to +60°C.
Spurious Emissions:	More than 80 dB below carrier.
Harmonic Emissions:	More than 90 dB below carrier.
Transmitter Mismatch Protection:	20:1 VSWR at all phase angles.
Transmitter Alarm:	Forward power sense and reverse VSWR; • open collector output (separate or 'OR'ed configuration); • linear output (separate lines only).
Operating Temperature Range:	-30°C to +60°C, optional -40°C temperature test.
Operating Humidity:	95% RH (non-condensing) at +25°C.
Operating Voltage:	+13.8 Vdc Nominal (range +11 to +16 Vdc), +9.5 Vdc Regulated.
Transmit Current:	1.2 Amps at 2 Watts RF Power Output, 2.5 Amps at 8 Watts RF Power Output
Front Panel Controls:	NORM (repeat mode), OFF, and KEY TX (Tx on).
PTT Activation:	• Active to ground with or without time-out-timer; • Microphone activated with or without time-out-timer; • Front Panel switch: KEY TX - without time-out-timer; • NORM - with or without time-out-timer. • Isolated (optional relay) with or without time-out-timer.

PTT Time-Out-Timer:	Selectable from 1 sec. to 8 hrs. (factory set 5 min.).
Reference Frequency:	9.600000 MHz.
Channel Spacing:	12.5 kHz or 25 kHz.
Frequency Stability:	Standard: ± 1 ppm, -40°C to $+60^{\circ}\text{C}$. Optional: high stability external reference provided through front panel connection.
Channel Selection:	In 12.5 kHz increments selected through four internal BCD rotary switches. Preset capability for 16 channel memory selectable through external control.
Standby Current and Rise time:	95% RF power, 95% system deviation within; <ul style="list-style-type: none"> • 50 ms: typically 7 mA (normal configuration); • 25 ms: typically 65 mA (synthesizer continuously enabled); • 10 ms: typically 90 mA (synth. and audio circuitry enabled).
DOC Type Approval	RSS119 142 194 241 RSS122 142 221 126
FCC Type Acceptance:	H4JUT-3-420-S02 (406-430 MHz, 0.5-2.0 Watt), H4JUT-3-420-S08 (406-430 MHz, 2.0-8.0 Watt), H4JUT-3-460-S02 (450-470 MHz, 0.5-2.0 Watt), H4JUT-3-460-S08 (450-470 MHz, 2.0-8.0 Watt).

Note: The transmitter is not to be operated within the 406 to 406.1 MHz frequency band, unless specifically authorized by COSPAS/SARSAT through the Federal Communications Commission and/or Industry Canada.

1.4.2 Audio Specifications

Audio Input:	Balanced 600 ohm or unbalanced (optional). Input level sensitivity, -25 dBm to 0 dBm.
Audio Response:	Pre-emphasis (6 dB per octave); +0.5 to -2.0 dB from 300 Hz to 3 kHz;
Flat Audio Response:	+1 to -1 dB from 100 Hz to 3 kHz.
Audio Deviation:	Preset to ± 1.5 kHz or ± 3.0 kHz with a 1 kHz tone; (capable ± 2.5 kHz or ± 5.0 kHz).
Subtone Audio Input 1:	0.5 Vpp at 200 Hz for ± 500 Hz deviation (internally adjustable).
Subtone Audio Input 1 Freq range:	60 Hz to 300 Hz.

Subtone Audio Input 2:	0.5 V _{pp} at 100 Hz for ±500 Hz deviation (internally adjustable).
Subtone Audio Input 2 Freq range:	DC to 150 Hz.
Direct Modulation Input:	0.5 V _{rms} at 1 kHz or ±3 kHz deviation.
Direct Modulation Freq range:	DC to 5 kHz.
Audio Distortion:	Less than 2.5% THD; 1 kHz tone at 1.5 kHz or 3 kHz deviation (-40°C to +60°C).
Hum and Noise:	Better than 40 dB (test receiver band limited: 400 Hz to 30 kHz).

1.4.3 Physical Specifications

Physical Dimensions:	Width:	Height:	Depth:
	7.1 cm (2.8 in)	12.8 cm (5.05 in)	19 cm (7.5 in)
Module Weight:	1.5 kg (3.3 lbs)		
Corrosion Prevention:	Anodized aluminum construction. Stainless steel hardware. Selectively conformal coated glass epoxy 2 and 4 layer printed circuitboards. Gold plated module connectors.		
Module Design:	Compact Eurostandard modular design. Plug-in modules mate with Daniels standard M3 repeater subrack. Subracks / modules comply with IEEE 1101, DIN 41494 and IEC 297-3 (mechanical size / modular arrangement).		
External Connections:	RF Connection: type N connector located on the transmitter module front panel. Motherboard Connections (Audio, Power, and Control) are made through a 48 pin, gold plated, type F connector on the rear of the transmitter module. User connection made through mated "motherboard" assembly of the repeater subrack. Type F standard connector complies with DIN 41612 Level 2 (200 mating cycles, 4 day 10 ppm SO ₂ gas test with no functional impairment and no change in contact resistance).		
Handle Text Colour:	Black.		

2 SYSTEM OVERVIEW

2.1 Transmitter Operation

3 ILLUSTRATIONS

3.1 MT-3 Transmitter Front Panel

4 PARTS LIST

5 REVISION HISTORY

ISSUE	DATE	DESCRIPTION AND (REASON)
3	August 98	• Manual formatted to modular style. All previous revision history in issue 2
4	December 98	• Added an advisory to our customers in section 1.1 and 1.4.1 that this transmitter is not to be operated within the 406 to 406.1 MHz frequency band.

This Page Intentionally Left Blank



MT-3 RADIO SYSTEMS

TRANSMITTER MAIN BOARD INSTRUCTION MANUAL

Covers: Version 1.7 of the Transmitter Main Board
Version 1.6 & 1.8 of the FM Audio Processor Board

Copyright © 1998 Daniels Electronics Ltd. All rights reserved. No part of this publication may be reproduced, stored in a retrieval system or transmitted in any form or by any means, electronic, mechanical, photocopying, recording or otherwise, without the prior written consent of Daniels Electronics Ltd.

DE™ is a registered trademark of Daniels Electronics Ltd. registered in the United States Patent and Trademark Office.

Issue: 3 Previous Issue: 2
Issue Date: November 98
Printing Date: NA
Part No.: IM20-MT3TXMN

Previous Issue Date: May 98

Daniels Electronics Ltd.
Victoria, B.C.
PRINTED IN CANADA

Reviewed By:

Quality Assurance:

Larry Freeman

Name

Signature

Date

NOTE:

The user's authority to operate this equipment could be revoked through any changes or modifications not expressly approved by Daniels Electronics Ltd.

The design of this equipment is subject to change due to continuous development. This equipment may incorporate minor changes in detail from the information contained in this manual.

TABLE OF CONTENTS

	Page
1 GENERAL	1-1
1.1 Introduction.....	1-1
1.2 Performance Specifications.....	1-1
1.2.1 General.....	1-1
1.2.2 Audio Specifications	1-2
2 THEORY OF OPERATION	2-1
2.1 Transmitter Main Board.....	2-1
2.1.1 General.....	2-1
2.1.2 Transmitter Push-To-Talk.....	2-1
2.1.2.1 Microphone PTT.....	2-1
2.1.2.2 PTT With Time-Out-Timer.....	2-2
2.1.2.3 PTT No Time-Out-Timer.....	2-2
2.1.2.4 Optional Relay	2-2
2.1.2.5 PTT Output.....	2-3
2.1.2.6 PTT Voltage Switching	2-3
2.1.2.7 Transmitter Standby Modes.....	2-3
2.1.3 Audio Circuits.....	2-4
2.1.3.1 Microphone Audio.....	2-5
2.1.3.2 Received Audio	2-5
2.1.4 Channel Selection.....	2-5
2.1.4.1 Synthesized Transmitter.....	2-5
2.1.4.2 Crystal Controlled Transmitter.....	2-6
2.1.5 Amplifier Circuits.....	2-6
2.1.6 Time-Out-Timer Circuitry.....	2-6
2.2 MT-3 Front Panel Board.....	2-8
2.3 MT-3 Audio Processor (Version 1.6)	2-8
2.3.1 General.....	2-8
2.3.2 Power Requirements	2-8
2.3.3 Audio Processor Turn-on Time.....	2-9
2.3.4 Audio Processor Signals.....	2-9
2.3.4.1 Audio Processor Outputs.....	2-9
2.3.4.2 Audio Processor Modulation Output	2-10
2.3.4.3 Audio Processor Low Frequency / Direct Mod. Output.....	2-10
2.3.4.4 Audio Processor Inputs.....	2-10
2.3.4.5 Audio Processor Microphone Input.....	2-11
2.3.4.6 Audio Processor Balanced Input.....	2-11
2.3.4.7 Audio Processor Auxiliary Input.....	2-11
2.3.4.8 Audio Processor Subtone Inputs.....	2-11
2.3.4.9 Audio Processor Direct Modulation Input	2-12
2.4 MT-3 Audio Processor (Version 1.8)	2-12

2.4.1	General.....	2-12
2.4.2	Power Requirements	2-12
2.4.3	Audio Processor Turn-on Time.....	2-13
2.4.4	Audio Processor Signals.....	2-13
2.4.4.1	Audio Processor Outputs	2-13
2.4.4.2	Audio Processor Modulation Output	2-14
2.4.4.3	Audio Processor Low Frequency / Direct Mod. Output.....	2-14
2.4.4.4	Audio Processor Inputs.....	2-14
2.4.4.5	Audio Processor Microphone Input.....	2-15
2.4.4.6	Audio Processor Balanced Input.....	2-15
2.4.4.7	Audio Processor Auxiliary Input.....	2-15
2.4.4.8	Audio Processor Subtone Inputs.....	2-15
2.4.4.9	Audio Processor Direct Modulation Input	2-16
2.5	Low Frequency Modulation.....	2-16
3	TRANSMITTER ALIGNMENT	3-1
3.1	General.....	3-1
3.2	Repair Note.....	3-1
3.3	Printed Circuitboard Numbering Convention.....	3-1
3.4	Recommended Test Equipment List.....	3-1
3.5	Standard Factory Settings and Jumper Configuration.....	3-2
3.5.1	MT-3 Transmitter Board Factory Configuration.....	3-2
3.5.2	MT-3 Audio Processor Factory Configuration	3-3
3.6	MT-3 Transmitter Board Alignment.....	3-4
3.6.1	General.....	3-4
3.6.2	MT-3 Transmitter Board Test Points	3-5
3.7	Module Installation and Removal.....	3-5
3.8	MT-3 Audio Processor Alignment.....	3-6
3.8.1	General.....	3-6
3.8.2	MT-3 Audio Processor Standard Deviation Adjustment	3-6
3.9	Standard Factory Settings and Jumper Configuration.....	3-8
3.9.1	MT-3 Audio Processor Factory Configuration (Version 1.8)	3-8
3.10	MT-3 Audio Processor Alignment (Version 1.8).....	3-10
3.10.1	General.....	3-10
3.10.2	MT-3 Audio Processor Standard Deviation Adjustment	3-10
3.11	Low Frequency Modulation Configuration.....	3-11
3.11.1	MT-3 Transmitters.....	3-11
3.11.2	MT-3 Transmitter Audio Processors.....	3-12
3.11.3	Synthesizer and Crystal Controlled Oscillator.....	3-13
3.11.4	Tuning the Transmitter.....	3-14
4	TRANSMITTER INTERCONNECT PIN DEFINITIONS	4-1
5	ILLUSTRATIONS AND SCHEMATIC DIAGRAMS.....	5-1
5.1	Transmitter Block Diagram.....	5-1
5.2	Transmitter Main Board Electrical Assembly.....	5-3

5.2.1	Transmitter Main Board Top Side Component Layout	5-3
5.2.2	Transmitter Main Board Bottom Side Component Layout	5-4
5.2.3	Transmitter Main Board Schematic Diagram	5-5
5.3	Front Panel Board.....	5-6
5.3.1	Front Panel Board Component Layout.....	5-6
5.3.2	Front Panel Board Schematic.....	5-7
5.4	Audio Processor Electrical Assembly (Version 1.6).....	5-8
5.4.1	Audio Processor Component Layout	5-8
5.4.2	Audio Processor Schematic Diagram.....	5-9
5.5	Audio Processor Electrical Assembly (Version 1.8).....	5-10
5.5.1	Audio Processor Component Layout	5-10
5.5.2	Audio Processor Schematic Diagram.....	5-11
5.5.3	TX Time-Out-Timer Electrical Assembly.....	5-12
5.5.3.1	TX Time-Out-Timer Component Layout.....	5-12
5.5.3.2	TX Time-Out-Timer Schematic Diagram	5-12
6	PARTS LISTS.....	6-1
6.1	Transmitter Main Board Parts List.....	6-1
6.1.1	Transmitter Main Board Electrical Parts List.....	6-1
6.1.2	Transmitter Main Board Mechanical Parts List.....	6-3
6.1.3	MT-3 Front Panel Board Electrical Parts List	6-4
6.2	MT-3 Audio Processor Parts List (Version 1.7)	6-4
6.2.1	MT-3 Audio Processor Electrical Parts List (Version 1.6).....	6-4
6.3	MT-3 Audio Processor Parts List (Version 1.8)	6-6
6.3.1	MT-3 Audio Processor Electrical Parts List (Version 1.8).....	6-6
7	REVISION HISTORY	7-1

1 GENERAL

1.1 Introduction

The MT-3 Transmitter Main Board integrates the MT-3 Front Panel Board, MT-3 Audio Processor, Synthesizer or Crystal Controlled Oscillator module, and Amplifier module together to comprise a MT-3 series transmitter (see section 5.1: MT-3 Transmitter Block Diagram). The Front Panel Board and the Audio Processor are soldered directly to the Transmitter Main Board while the Amplifier and the Synthesizer or Crystal Controlled Oscillator module are frequency band sensitive, plug-in modules. Circuitry and jumpers on the Transmitter Main Board control the operation of the modules as well as the overall operation of the MT-3 transmitter. Power and signal connections are made through the 48 pin type 'F' connector on the rear of the Transmitter Main Board where they are then routed to the other MT-3 modules. The front and rear panels are attached to the Transmitter Main Board and together with the extruded aluminum shell, form the transmitter enclosure.

1.2 Performance Specifications

1.2.1 General

Type:	MT-3 Series Transmitter
Compatibility:	MT-3 Series Amplifier, OC-3 Crystal Controlled Oscillator module, OS-3 and OS-3H Frequency Synthesizer modules.
Modulation:	11K0F3E or 16K0F3E (Frequency Modulation).
Operating Temperature Range:	-30°C to +60°C, optional -40°C to +60°C temperature test.
Operating Humidity:	95% RH (non-condensing) at +25°C.
Operating Voltage:	+9.5 Vdc Regulated. +13.8 Vdc Nominal (11 - 16 Vdc).
Front Panel Controls:	NORM (repeat mode), OFF, and KEY TX (Tx on).
PTT Activation:	<ul style="list-style-type: none">• Active to ground with or without time-out-timer;• Microphone activated with or without time-out-timer;• Front Panel switch: KEY TX - without time-out-timer;• NORM - with or without time-out-timer.• Isolated (optional relay) with or without time-out-timer.
PTT Time-Out-Timer:	Selectable from 1 sec. to 8 hrs. (Factory Default: 5 min.).

1.2.2 Audio Specifications

Audio Input:	Balanced 600 ohm or unbalanced (optional). Input level sensitivity, -25 dBm to 0 dBm.
Audio Response:	Pre-emphasis (6 dB per octave); +0.5 to -2.0 dB from 300 Hz to 3 kHz;
Flat Audio Response:	+1 to -1 dB from 100 Hz to 3 kHz.
Audio Deviation:	Preset to ± 1.5 kHz (Narrow Band) or ± 3.0 kHz (Wide Band) with a 1 kHz tone (capable ± 2.5 kHz or ± 5.0 kHz).
Subtone Audio Input 1:	0.5 Vpp at 200 Hz for ± 500 Hz deviation (internally adjustable).
Subtone Audio Input 1 Frequency range:	60 Hz to 300 Hz.
Subtone Audio Input 2:	0.5 Vpp at 100 Hz for ± 500 Hz deviation (internally adjustable).
Subtone Audio Input 2 Frequency range:	DC to 150 Hz.
Direct Modulation Input:	0.5 Vrms at 1 kHz or ± 3 kHz deviation.
Direct Modulation Frequency range:	DC to 5 kHz.

2 THEORY OF OPERATION

2.1 Transmitter Main Board

2.1.1 General

3 TRANSMITTER ALIGNMENT

3.1 General

Transmitter alignment is simplified by using an M-3 Subrack, SM-3 System Monitor, and RF extender cable to provide transmitter power and signal interconnection. Alternatively, +9.5 Vdc and +13.8 Vdc may be applied directly to a transmitter module through positive connection for the +9.5 Vdc to pins B6 and Z6, for the +13.8 Vdc to pins B2 and Z2, and negative connection to pins B30, Z30, B32, and Z32. Transmitter balanced audio (600 Ω) is available at pins B18 and Z18.

3.2 Repair Note

MT-3 Transmitter modules are mainly made up of surface mount devices which should not be removed or replaced using an ordinary soldering iron. Removal and replacement of surface mount components should be performed only with specifically designed surface mount rework and repair stations complete with ElectroStatic Dissipative (ESD) protection.

When removing Surface Mount Solder Jumpers, it is recommended to use solder braid in place of manual vacuum type desoldering tools when removing jumpers. This will help prevent damage to the circuitboards.

3.3 Printed Circuitboard Numbering Convention

To ease troubleshooting and maintenance procedures, Daniels Electronics Limited has adopted a printed circuitboard (PCB) numbering convention in which the last two digits of the circuitboard number represent the circuitboard version. For example:

- PCB number 43-912010 indicates circuitboard version 1.0;
- PCB number 50002-02 indicates circuitboard version 2.0.

All PCB's manufactured by Daniels Electronics are identified by one of the above conventions.

3.4 Recommended Test Equipment List

Alignment of the complete transmitter requires the following test equipment or its equivalent. It is assumed that any adjustment of the Transmitter Main Board will also involve the other modules.

Dual Power Supply:	Regulated +9.5 Vdc at 2 A. Regulated +13.8 Vdc at 2 A - Topward TPS-4000
Oscilloscope / Multimeter:	Fluke 97 Scopemeter
Current Meter:	Fluke 75 multimeter

Radio communications test set : Marconi Instruments 2955R
 VSWR 3:1 mismatch load: JFW 50T-035-3.0:1
 Alignment Tool: Johanson 4192

It is recommended that the radio communications test set be frequency locked to an external reference (WWVH, GPS, Loran C) so that the high stability oscillator may be accurately set to within its ± 1 ppm frequency tolerance.

3.5 Standard Factory Settings and Jumper Configuration

Standard factory settings and the associated jumper configuration for each module of the MT-3 series transmitter are given below.

3.5.1 MT-3 Transmitter Board Factory Configuration

The MT-3 Transmitter Main Board is factory configured as follows:

- Transmitter standby mode 1 (lowest standby current consumption).
- Receiver squelched, de-emphasized audio amplifier disabled.
- Optional relay not installed.
- Separate amplifier power sense outputs.

The corresponding jumper settings are:

• Jumper J2:	'x' position	Optional relay configuration
• Jumper J3:	no connection	Optional relay configuration
• Jumper J4:	'y' position	Optional relay configuration
• Jumper J6:	not installed	Transmitter standby mode select - Mode 1
• Jumper J7:	'y' position	Audio processor standby mode select
• Jumper J9:	not installed	Receiver audio ac/dc input coupling
• Jumper J12:	not installed	Amplifier power sense output configuration
• Jumper J13:	'x' position	Amplifier power sense output configuration
• Jumper J14:	'x' position	Amplifier power sense output configuration
• Jumper J15:	'x' position	Amplifier power sense output configuration
• Jumper J16:	'x' position	Microphone configuration
• Jumper J17:	installed	Microphone output line
• Jumper J18:	'y' position	Synthesizer or crystal module standby mode select
• Jumper J19:	'x' position	600 Ω audio transformer enable. 'y' position disables
• Jumper J20:	'x' position	600 Ω audio transformer enable. 'y' position disables
• Jumper J21:	not installed	+8 Vdc audio processor supply bypass
• Jumper J22:	'x' position	600 Ω audio transformer enable. 'y' position disables
• Jumper J23:	'x' position	600 Ω audio transformer enable. 'y' position disables
• Jumper J24:	installed	Subtone #2 output enable
• Jumper J25:	'x' position	Audio output enable

• Jumper J26:	installed	Time-Out-Timer Timing resistor select.
• Jumper J27:	not installed	Time-Out-Timer Timing resistor select.
• Jumper J28:	not installed	Time-Out-Timer Timing period output select.
• Jumper J29:	installed	Time-Out-Timer Timing period output select.
• Jumper J31:	installed	Time-Out-Timer Timing period output select.
• Jumper J32:	not installed	Time-Out-Timer Timing period output select.
• Jumper J33:	installed	Time-Out-Timer input enable
• Jumper J34:	installed	Time-Out-Timer power enable
• Jumper J35:	installed	Time-Out-Timer output enable

Note: Jumpers J1, J5, J8, J10, J11 designations not used

3.5.2 MT-3 Audio Processor Factory Configuration (Version 1.6)

The MT-3 Audio Processor is factory configured as follows:

- Maximum Deviation: ± 2.5 kHz (12.5 kHz or 15 kHz channel),
 ± 5.0 kHz (25 kHz or 30 kHz channel).
- Microphone Input: 1 kHz signal at -10 dBm gives $\pm 50\%$ maximum deviation,
1 kHz signal compression set at $\pm 60\%$ maximum deviation.
- Audio Balanced Input: Enabled - pre-emphasis response,
1 kHz tone at -8 dBm gives $\pm 60\%$ maximum deviation.
1 kHz signal compression set at $\pm 60\%$ maximum deviation.
- Subtone Input 1: 100 Hz tone at -18 dBm gives ± 500 Hz deviation.
- All other audio inputs: Disabled.
- Time-Out-Timer: 5 minutes \pm 30 seconds.

The corresponding Audio Processor jumper settings are:

- Jumper JU1: not installed Power source select for Direct Modulation circuits.
- Jumper JU2: not installed MT-2 deviation enable (MT-2 transmitters).
- Jumper JU3: installed Microphone preamplifier power enable.
- Jumper JU4: installed Balanced audio preamplifier power enable.
- Jumper JU5: not installed Balanced audio ground enable.
- Jumper JU6: installed Processed audio path enable (limited and filtered).
- Jumper JU7: not installed Unprocessed auxiliary audio path enable (unfiltered).
- Jumper JU8: not installed Audio output DC coupled (MT-2 transmitters).
- Jumper JU9: installed Balanced input preemphasis response enable.
- Jumper JU10: not installed Balanced input flat audio response enable.

- Jumper JU11: not installed Balanced input to auxiliary audio circuit enable.
- Jumper JU12: not installed Tone/Digital input to auxiliary audio circuit enable.
- Jumper JU13: not installed Direct modulation input to auxiliary audio circuit enable.
- Jumper JU14: not installed Auxiliary input preemphasis response enable.
- Jumper JU15: not installed Auxiliary input flat audio response enable.
- Jumper JU16: not installed Subtone input 2 audio path select.
- Jumper JU17: installed MT-2 Temperature compensation bypass.
- Jumper JU18: not installed Continuous data mode selection.
- Jumper JU19: 'y' position Power source for audio switches.
- Jumper JU20 to JU22: not used
- Jumper JU23: not installed Direct modulation input to subtone 2 enable.
- Jumper JU24: installed Lowpass filter response select.
- Jumper JU25: installed Lowpass filter response select.
- Jumper JU26: installed Lowpass filter response select.
- Jumper JU27: not installed Direct Modulation input audio path select.
- Jumper JU28: not installed Amplified direct modulation bypass.
- Jumper JU29: not installed Amplified direct modulation input DC couple enable.
- Jumper JU30: not installed Amplified direct modulation audio path select.
- Jumper JU31: not installed Subtone 2, AC coupled, to direct modulation output enable.
- Jumper JU32: not installed Audio output AC coupled (MT-3 crystal transmitters).
- Jumper JU33: not installed Audio output AC coupled (MT-3 synthesized transmitters).
- Jumper JU34: not installed Audio output from Direct Modulation circuits select.
- Jumper JU35: not installed Direct Modulation output source select.
- Jumper JU36: 'x' position Subtone input 1 audio path select.
- Jumper JU37: not installed Summed Subtone audio to direct modulation output enable
- Jumper JU38: not installed Subtone 2, DC coupled, to direct modulation output select.
- Jumper JU39: not installed Direct Modulation low input impedance enable.

3.6 MT-3 Transmitter Board Alignment

3.6.1 General

Before proceeding with the transmitter alignment, check that the appropriate jumpers are installed. The standard jumper configuration for the Transmitter Main Board, given in section 3.5.1, is normally employed for transmitter alignment. In a standard configuration, the only alignment required on the MT-3 Transmitter Main Board for a synthesized transmitter is to set the frequency switches (FSW1, FSW2, FSW3, and FSW4) for the desired channel frequency. FSW1 is the most significant digit of the frequency switches. The switch settings for the desired channel frequency can be found in the channel designation tables. If the transmitter is using a crystal control oscillator module, the switch settings are irrelevant.

3.6.2 MT-3 Transmitter Board Test Points

- TP1: squelched, de-emphasized audio / +13.8 Vdc
- TP2: microphone audio
- TP3: microphone PTT WTO; inactive +9.5 Vdc, active 0 Vdc
- TP4: microphone PTT NTO; inactive +9.5 Vdc, active 0 Vdc
- TP5: +9.5 Vdc from backplane connector
- TP6: +9.5 Vdc from front panel board
- TP7: +9.5 Vdc Switched
- TP8: Qualified PTT; inactive +9.5 Vdc, active 0 Vdc: activated by synthesizer
- TP9: synthesizer enable; selected by J18
- TP10: synthesizer bootstrap line; +5 Vdc
- TP11: synthesizer PTT input; inactive +9.5 Vdc, active 0 Vdc
- TP12: audio processor TOT input; inactive +9.5 Vdc, active 0 Vdc
- TP13: audio processor TOT output; inactive +9.5 Vdc, active 0 Vdc
- TP14: audio processor audio output
- TP15: audio processor audio control line
- TP16: audio processor subtone #2 output
- TP17: audio processor direct modulation input
- TP18: audio processor subtone #2 input
- TP19: audio processor continuous +9.5 Vdc
- TP20: audio processor subtone #1 input
- TP21: audio processor supply +8 Vdc, selected by J7
- TP22: audio processor tone/digital input
- TP23: synthesizer receive data line; 0 Vdc
- TP24: synthesizer transmit data line; +5 Vdc
- TP25: Q1 collector; inactive 0 Vdc, active +9.5 Vdc
- TP26: U2d output; inactive +9.5 Vdc, active 0 Vdc
- TP27: U1a output (PTT WTO); inactive +9.5 Vdc, active 0 Vdc
- TP28: U1b output (PTT NTO); inactive +9.5 Vdc, active 0 Vdc
- TP29: Q6 collector / Q7 gate; inactive +9.5 Vdc, active 0 Vdc
- TP30: +9.5 Vdc PTT Switched
- TP31: U8 pin 1, Time-Out-Timer circuitry set input
- TP32: U8 pin 2, Time-Out-Timer circuitry reset input
- TP33: Audio processor balanced audio input
- TP34: Audio processor balanced audio input

3.7 Module Installation and Removal

Installation of the Enhanced Synthesizer or Crystal Controlled Oscillator module is facilitated by alignment pins on each corner of the module. When the four pins are aligned with their corresponding hole in the Transmitter Main Board, push the module down, taking care to ensure the connector pins on the bottom of the Synthesizer or Crystal Controlled Oscillator module are not bent.

To remove the Enhanced Synthesizer or Crystal Controlled Oscillator module, simply remove the center screw from the module lid and pull the module out. The module should be pulled straight out so that the four alignment pins do not bend or damage the circuitboard.

The Low Power Synthesizer uses two tabs soldered to the Transmitter Main Board for mounting. No alignment pins are used. As a result care must be taken to ensure the connector pins on the bottom of the Synthesizer are not bent. To install the low Power Synthesizer module, remove the two of the synthesizer side screws that correspond to the tabs on the Transmitter Main board and install the synthesizer module taking care not to bend the pins. Replace the two side screws; installing them through the tabs to hold the synthesizer module in place.

When removing the Low Power Synthesizer module, it is important to gently lift the synthesizer module "straight out" in order to prevent damage to the connector pins. Remove the two side screws holding the synthesizer module to the tabs. Using a plastic coated lifting tool, such as a small screwdriver with the tip covered in heat shrink material, gently lift the synthesizer module from the Transmitter Main Board by applying pressure in a rotating fashion about four corners of the synthesizer module. Replace the two side screws.

3.8 MT-3 Audio Processor Alignment (Version 1.6)

3.8.1 General

Verify the standard factory settings for the MT-3 Audio Processor as given in section 3.5.2 before beginning the standard deviation adjustment procedure. If the transmitter's channel frequency changes, the audio processor should be realigned to optimize the transmitter's performance. The schematic diagram for the audio processor is shown in section 5.4.2 and the component layout is shown in section 5.4.1.

3.8.2 MT-3 Audio Processor Standard Deviation Adjustment

Note: clockwise rotation of controls increases signal levels.

- 1 Connect the transmitter to the radio communications test set and monitor FM deviation, distortion, and audio frequency. Before adjusting the audio deviation, confirm that the transmitter RF output frequency is correct.
- 2 Connect the 600 ohm input to the incoming audio (pins B18, Z18). Set the audio frequency to 1 kHz at the desired level of -8 dBm.
- 3 Increase the balance level control (R31) for maximum gain.

- 4 Turn the transmitter on.
- 5 Adjust the balance compression level (R38) for compression at $\pm 60\%$ maximum deviation.
- 6 Set the audio frequency to 2.4 kHz, then adjust the deviation control (R29) for maximum deviation.
- 7 Reset the modulating frequency to 1 kHz and re-adjust R38 for $\pm 60\%$ maximum deviation.
- 8 Repeat steps 6 and 7 until both conditions are met.
- 9 Vary the audio signal from 1 kHz to 3 kHz and measure the positive deviation and then the negative deviation. Adjust the symmetry control (R14) until the \pm deviation is symmetrical. The variation between \pm deviation levels should not exceed 300 Hz over the 1 kHz to 3 kHz range.
- 10 Repeat steps 6 and 7 and re-adjust if necessary.
- 11 Adjust the balanced input level control (R31) until the deviation produced by a 1 kHz tone at -8 dBm falls below $\pm 60\%$ maximum deviation, then adjust R31 so that the deviation increases until compression is observed. The deviation should be ± 1.5 kHz or ± 3 kHz for narrowband and wideband channels respectively.
- 12 A 1 kHz tone at -8 dBm input level should produce $\pm 60\%$ maximum deviation. If not, go back to step 4 and make sure the pot is set for maximum gain and repeat the procedure. If so, increasing the input level by +20 dBm should not increase the deviation. This confirms that the AGC action of preamplifier U2 is working.
- 13 A 2.4 kHz tone at the desired audio input level should produce the maximum deviation. Increasing the input level by +20 dBm should not increase the deviation. This confirms that the limiting action of U4a and U5a is working.
- 14 Set the audio frequency back to 1 kHz at -8 dBm output. Confirm and record audio distortion with the appropriate filter on the communications test set.
- 15 Confirm the audio frequency response by referencing all output deviation measurements to a 1 kHz input tone at $\pm 20\%$ maximum deviation (± 500 Hz for narrowband or ± 1 kHz for wideband).
- 16 Remove the signal to the balanced input (pins B18, Z18).

- 17 Apply a 1 kHz tone at -8 dBm to the microphone audio input. Set the microphone compression control (R8) to produce $\pm 60\%$ maximum deviation. Reduce the signal to -10 dBm and adjust the microphone input level control (R2) for $\pm 50\%$ maximum deviation. Remove the signal.
18. Apply a 100 Hz tone at -18 dBm to the subtone 1 input and adjust the subtone 1 level control (R42) to produce ± 500 Hz deviation. Remove the signal.

3.9 Standard Factory Settings and Jumper Configuration

Standard factory settings and the associated jumper configuration for the MT-3 Audio Processor (Version 1.8) are given below.

3.9.1 MT-3 Audio Processor Factory Configuration (Version 1.8)

The MT-3 Audio Processor is factory configured as follows:

- Maximum Deviation: ± 2.5 kHz (12.5 kHz or 15 kHz channel),
 ± 5.0 kHz (25 kHz or 30 kHz channel).
- Microphone Input: 1 kHz signal at -10 dBm gives $\pm 50\%$ maximum deviation,
1 kHz signal compression set at $\pm 60\%$ maximum deviation.
- Audio Balanced Input: Enabled - pre-emphasis response,
1 kHz tone at -8 dBm gives $\pm 60\%$ maximum deviation.
1 kHz signal compression set at $\pm 60\%$ maximum deviation.
- Subtone Input 1: 100 Hz tone at -18 dBm gives ± 500 Hz deviation.
- All other audio inputs: Disabled.
- Time-Out-Timer: 5 minutes \pm 30 seconds.

The corresponding Audio Processor jumper settings are:

- Jumper JU1: not installed Power source select for Direct Modulation circuits.
- Jumper JU2: not installed MT-2 deviation enable (MT-2 transmitters).
- Jumper JU3: 'y' position Microphone preamplifier flat response.
- Jumper JU4: not installed Subtone input 2 audio path select.
- Jumper JU5: not installed Auxiliary input enable (DC or AC coupled).
- Jumper JU6: installed Processed audio path enable (limited and filtered).
- Jumper JU7: not installed Unprocessed auxiliary audio path enable (unfiltered).
- Jumper JU8: not installed Audio output DC coupled (MT-2 transmitters).
- Jumper JU9: installed Balanced input preemphasis response enable.

- Jumper JU10: not installed Balanced input flat audio response enable.
- Jumper JU11: 'y' position Balanced input to auxiliary audio circuit enable.
- Jumper JU12: not installed Tone/Digital input to auxiliary audio circuit enable.
- Jumper JU13: not installed Direct modulation input to auxiliary audio circuit enable.
- Jumper JU14: not installed Auxiliary input preemphasis response enable.
- Jumper JU15: not installed Auxiliary input flat audio response enable.
- Jumper JU16: installed Subtone input 1 audio path select.
- Jumper JU17: not installed MT-2 Temperature compensation bypass.
- Jumper JU18: not installed Continuous data mode selection.
- Jumper JU19: not installed Power source for audio switches.
- Jumper JU20: not installed Power source for Q2.
- Jumper JU21: not installed Power source for bilateral switch U9.
- Jumper JU22: 'x' position Audio output to lowpass filter
- Jumper JU23: not installed Direct modulation input to subtone 2 enable.
- Jumper JU24: installed Lowpass filter response select.
- Jumper JU25: installed Lowpass filter response select.
- Jumper JU26: installed Lowpass filter response select.
- Jumper JU27: not installed Direct modulation input audio path select.
- Jumper JU28: not installed Amplified direct modulation bypass.
- Jumper JU29: not installed Amplified direct modulation input DC coupled enable.
- Jumper JU30: not installed Amplified direct modulation audio path select.
- Jumper JU31: not installed Audio output AC coupled (MT-3 synthesized transmitters)
- Jumper JU32: not installed Audio output AC coupled (MT-3 crystal transmitters).
- Jumper JU33: installed Audio output AC coupled.
- Jumper JU34: not installed Audio output from direct modulation circuits select.
- Jumper JU35: not installed Direct Modulation output source select.
- Jumper JU36: 'y' position Power source select for AGC Preamplifier.
- Jumper JU37: not installed Direct modulation output enable.
- Jumper JU38: not installed Subtone 2, DC coupled, to direct modulation output select.
- Jumper JU39: not installed Direct modulation low input impedance enable.
- Jumper JU40: installed Power for Microphone preamplifier enable.
- Jumper JU41: not used.
- Jumper JU42: not installed Processed audio path to direct modulation output.
- Jumper JU43: installed Bilateral switch U9 bypass enable.

3.10 MT-3 Audio Processor Alignment (Version 1.8)

3.10.1 General

Verify the standard factory settings for the MT-3 Audio Processor as given in section 3.9.1 before beginning the standard deviation adjustment procedure. If the transmitter's channel frequency changes, the audio processor should be realigned to optimize the transmitter's performance. The schematic diagram for the audio processor is shown in section 5.5.2 and the component layout is shown in section 5.5.1.

3.10.2 MT-3 Audio Processor Standard Deviation Adjustment

Note: clockwise rotation of controls increases signal levels.

- 1 Connect the transmitter to the radio communications test set and monitor FM deviation, distortion, and audio frequency. Before adjusting the audio deviation, confirm that the transmitter RF output frequency is correct.
- 2 Connect the 600 ohm input to the incoming audio (pins B18, Z18). Set the audio frequency to 1 kHz at the desired level of -8 dBm.
- 3 Increase the balance level control (R31) so that the deviation increases until compression is observed.
- 4 Adjust the compression control pot (R38) for compression at $\pm 60\%$ maximum deviation.
- 5 Set the audio frequency to 2.4 kHz, then adjust the deviation control (R29) for maximum deviation.
- 6 Reset the modulating frequency to 1 kHz and re-adjust R38 for $\pm 60\%$ maximum deviation.
- 7 Repeat steps 4 and 6 until both conditions are met.
- 8 Vary the audio signal from 1 kHz to 3 kHz and measure the positive deviation and then the negative deviation. Adjust the symmetry control (R14) until the \pm deviation is symmetrical. The variation between \pm deviation levels should not exceed 300 Hz over the 1 kHz to 3 kHz range.
- 9 Repeat steps 4 and 6 and re-adjust if necessary.

- 10 Adjust the balanced input level control (R31) so that the deviation increases until compression is observed. The deviation should be ± 1.5 kHz or ± 3 kHz for narrowband and wideband channels respectively.
- 11 Increase the input level (R31) by +20 dBm, it should not increase the deviation more than maximum. This confirms that the AGC action of preamplifier U1 is working.
- 12 A 2.4 kHz tone at the desired audio input level should produce the maximum deviation. Increasing the input level by +20 dBm should not increase the deviation. This confirms that the limiting action of U4a and U5a is working.
- 13 Set the audio frequency back to 1 kHz at -8 dBm output. Confirm and record audio distortion with the appropriate filter on the communications test set.
- 14 Confirm the audio frequency response by referencing all output deviation measurements to a 1 kHz input tone at $\pm 20\%$ maximum deviation (± 500 Hz for narrowband or ± 1 kHz for wideband). Remove the signal to the balanced input (pins B18, Z18).
- 15 Apply a 1 kHz tone at -8 dBm to the microphone audio input. Set the microphone compression control (R2) to produce $\pm 50\%$ maximum deviation. Reduce the signal to -10 dBm and adjust the microphone input level control (R2) for $\pm 50\%$ maximum deviation. Remove the signal.
16. Apply a 100 Hz tone at -18 dBm to the subtone 1 input and adjust the subtone 1 level control (R42) to produce ± 500 Hz deviation. Remove the signal.

3.11 Low Frequency Modulation Configuration

Note: the following information originates from Daniels Electronics document number A0361-06.

3.11.1 MT-3 Transmitters

For transmitters, the LTR™ or DCS signal should be applied to the DIRECT MODULATION input (pin Z28), which is also available on the M-3 and SR-3 motherboards at the control connectors J1, P1, or J7 on pins B20 (TX A DIR MOD) and A20 (TX B DIR MOD). **The signal from an LTR™ or DCS encoder should be applied through a 47k resistor to reduce the loading effect of the DIRECT MODULATION input.** The signal should be capacitively coupled to avoid pulling the transmitter frequency off centre. Most LTR™ and DCS encoder modules already have a capacitive output. Note that the controller generating the low frequency signal will need to key the transmitter's PTT input. Note that the synthesizer and the audio processor may require modifications as described later in this document.

MT-3 Transmitter (board version 43-920910 through 43-920911)

- J6 installed (synthesizer always powered up by +9.5V SWITCHED line).
- J7 installed in 'X' position (audio processor always powered up by +9.5V SWITCHED line).
- solder a wire from JA4-2 of main board to J51-18 of synthesizer. This connects the subtone output 2 to the synthesizer's phase modulation input.

MT-3 Transmitter (board version 43-920912 through 43-920913)

- J6 installed (synthesizer always powered up by +9.5V SWITCHED line).
- J7 installed in 'X' position (audio processor always powered up by +9.5V SWITCHED line).

MT-3 Transmitter (board version 43-920914 or higher)

- J6 installed (+9.5V SWITCHED line always powered).
- J7 installed in 'X' position. (audio processor always powered up by +9.5V SWITCHED line).
- J18 installed in the 'X' position (synthesizer always powered up by +9.5V SWITCHED line).

LTR™ is a Trademark of E.F. Johnson Company.

3.11.2 MT-3 Transmitter Audio Processors

MT-3 Transmitter Audio Processor (board version 43-911910 through 43-911913)

- Remove R47 to avoid having too low an input impedance.
- Change C40 to a 10 uF tantalum capacitor (stock code 1054-6E106M25) with the "+" polarity mark nearest to the edge of the PCB (see figure 3-1). This allows low frequencies to pass.
- Short pins P4-1 and P4-3 (or install J23) together with a short piece of 22 or 24 gauge solid wire and solder (see diagram below). This allows the DIRECT MODULATION

- input to the transmitter to be used to gain access to the SUBTONE INPUT 2 which connects to the PHASE MOD IN input of a modified synthesizer.
- Make sure J13 and J16 are not installed.

Figure 3-1 Transmitter Audio Processor Low Frequency Modulation.

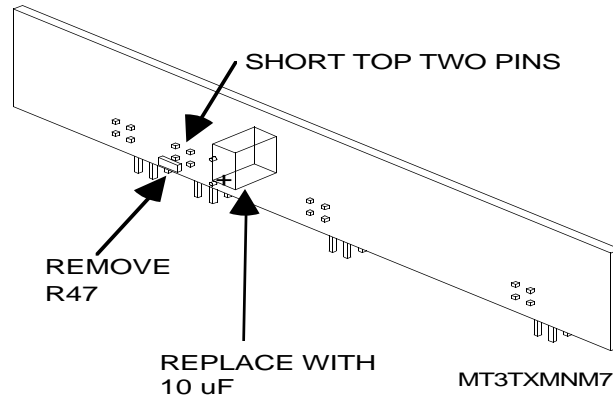

MT-3 Transmitter Audio Processor (board version 43-911914 through 43-911916)

- Install jumpers: JU38Y, JU35Y
- Remove jumpers: JU27X, JU27Y, JU31, JU35X, JU37, JU38X
- Short pins P4-1 and P4-3 (or install J23) together with a short piece of 22 or 24 gauge solid wire and solder (see figure 3-1). This allows the DIRECT MODULATION input to the transmitter to be used to gain access to the SUBTONE INPUT 2 which connects to the PHASE MOD IN input of a modified synthesizer.

Note that the SUBTONE 2 input should not be used while this modification is in effect. Note also that adjusting R44 has no effect on the deviation of the low frequency signal.

MT-3 Transmitter Audio Processor (board version 43-911918)

- Contact factory for configuration.

3.11.3 Synthesizer and Crystal Controlled Oscillator

Refer to the manual for the Oscillator used in your Transmitter for the required Low Frequency Modulation modifications.

3.11.4 Tuning the Transmitter

For all MT-3 transmitters, apply a low impedance source of 20-300 Hz to the Direct Modulation input of the transmitter (Pin Z28 of the 48 pin connector) through a 22 uF capacitor, positive terminal connected to pin Z28. A Marconi 2955 works well for this test. Adjust R44 on the audio processor to the fully clockwise position.

- Apply a 100 Hz tone at -8 dBm to the Direct Modulation input of the transmitter (Pin Z28 of the 48 pin connector), and key the transmitter. Adjust the level of the tone until a deviation of 1.5 kHz is achieved. Note that the level required may be anywhere from -10 dBm to 0 dBm depending on the type of transmitter.
- Confirm that the frequency response rolls off by checking that the following deviations are observed: (note that the deviation will NOT roll off at 300 Hz if an OC-3 crystal oscillator is used instead of a synthesizer).
 - 20 Hz tone gives about 700 Hz deviation
 - 100 Hz tone gives 1.5 kHz deviation
 - 300 Hz tone gives about 500 Hz deviation
- Finally, confirm subtone 1 modulation: set-up for 100 Hz Mod with 500 Hz Dev.
 - Check 200 Hz Mod, Dev = $\frac{1.5 \text{ (VHF)}}{2.0 \text{ kHz (UHF)}}$
 - Check 300 Hz Mod, Dev = $\frac{1.5 \text{ (VHF)}}{4.0 \text{ kHz (UHF)}}$

4 TRANSMITTER INTERCONNECT PIN DEFINITIONS

The MT-3 series Transmitter employs a 48 pin Eurostandard connector for interfacing to all transmitter power, audio, and control functions. The following are the MT-3 series Transmitter backplane connections to the M-3 Motherboard.

Pin	Name	Pin	Name	Pin	Name
D2	No Connect	B2	+13.8 Vdc	Z2	+13.8 Vdc
D4	No Connect	B4	MIC Out	Z4	MIC In
D6	No Connect	B6	+9.5 Vdc	Z6	+9.5 Vdc
D8	No Connect	B8	Relay Positive	Z8	Relay Negative
D10	No Connect	B10	PTT WTO	Z10	PTT WTO
D12	No Connect	B12	Tx Standby	Z12	Tx Standby
D14	No Connect (IMC1)	B14	PTT NTO	Z14	PTT NTO
D16	No Connect (IMC2)	B16	No Connect (MT-2 +9.5V)	Z16	No Connect (MT-2 +9.5V)
D18	No Connect (IMC3)	B18	Balanced Input 2	Z18	Balanced Input 1
D20	Channel Select 0 (LSB)	B20	Squelched,De-emph Audio	Z20	Squelched, Flat Audio
D22	Channel Select 1	B22	Subtone Input 1	Z22	Tx Audio Control
D24	Channel Select 2	B24	PTT Output	Z24	Subtone Input 2
D26	Channel Select 3 (MSB)	B26	Forward Power Sense	Z26	Reverse Power Sense
D28	Synth Tx Data (Output)	B28	Monitor Out	Z28	Direct Mod Input
D30	Synth Rx Data (Input)	B30	Ground	Z30	Ground
D32	Synth Bootstrap (Input)	B32	Ground	Z32	Ground

This Page Intentionally Left Blank

5 ILLUSTRATIONS AND SCHEMATIC DIAGRAMS

5.1 Transmitter Block Diagram

6 PARTS LISTS

6.1 Transmitter Main Board Parts List

7 REVISION HISTORY

ISSUE	DATE	REVISION
-------	------	----------

- | | | |
|---|-----------|--|
| 1 | August 97 | First Issue. |
| | Sept. 97 | Included PCB version 1.4 Component Layout and Schematic diagrams. |
| 2 | Dec 97 | Main PCB version now 1.7 (ECO 515). <ul style="list-style-type: none">• BCD Switches changed from Surface Mount Part to Through Hole Part.• Audio Amplifier was removed because this option was never used.• Added Timer Out Timer circuitry to Main Tx Board.• TOT PCB no longer installed on Audio Processor. For
A21-TX3-00 TX MAIN/FP, MT-3, STANDARD
A21-TX3-30 TX MAIN/FP, MT-3, + REF. INPUT
TUBING, TFE-260C,14AWG T/W,CLR 7610-260C14TW
18mm Long and Consummable Buss Wire 16 Awg 40mm Long
NOW NOT INSTALLED |
| | Dec 97 | For
A21-TX3-01 TX MAIN/FP, MT-3, WITH FUSE
A21-TX3-02 TX MAIN/FP, MT-3, + DC RELAY
A21-TX3-03 TX MAIN/FP, MT-3, + FUSE,RELAY <ul style="list-style-type: none">• Removed Jumpers J1, J5, J8, J10, J11.• Added Jumpers J22 - J29, J31 - J35.• Added Test Points TP28 - TP34 |
| | Dec 97 | Front Panel Board version now 1.2 (ECO 521).
Modified MT-3 Tx Front Panel Board (FPB) to support all options on the New Transmitter Main Board . Also, the Front Panel Board is now easier to configure if new microphones (other than Daniels microphones) are used. The new FPB can be used on the old TX-3 main - all options will function. However, the old version of FPB will NOT work with the new version TX-3 Main PCB (unless you hard wire one of the microphone pins into the main PCB (13.8V line.)
Added J2 SM Jumper. This jumper now selects Rx Audio or 13.8V to Pin 4 of the Microphone. This capability used to be selected by a jumper on the Main Tx Board. For Normal Opertion J2 'x' position must be installed
Options - This is for future use (not used now). Added 2x4 header land pattern to Tx Front Panel Board. A 2x4 header can be installed to make other microphones compatible with Daniels Transmitters. |
| 3 | Nov 98 | MT-3 FM Audio Processor now version 1.8
The MT-3 FM Audio Processor was re-designed because the IC, XXXXXX, XXXXXX, SO-8 is no longer available from the supplier. Also, the new design improves the flat and 300Hz Pre-emphasis audio responses.
Included PCB version 1.8 Component Layout, Schematic diagram, Parts List and Section 2.4, 3.9 and 3.10. |

ISSUE	DATE	REVISION
3	Nov 98	Updated the DE logo and added the statutory trademark statement to the title page. Updated the Low Frequency Modulation section 3.11 to reflect the in house document A0361-06.



MT-3 RADIO SYSTEMS

Audio Processor Instruction Manual For AM/FM Transmitters

Covers the following
V 2.2 and V2.3 of the FM Audio Processor Board
used in the VT-3/xxx, UT-3/xxx, VT-3Hxxx and
A22-VAP130 AM Audio Processor Version 04

Copyright © 2000 Daniels Electronics Ltd. All rights reserved. No part of this publication may be reproduced, stored in a retrieval system or transmitted in any form or by any means, electronic, mechanical, photocopying, recording or otherwise, without the prior written consent of Daniels Electronics Ltd.

DE™ is a registered trademark of Daniels Electronic Ltd. registered in the U.S. Patent and Trademark Office.

Issue:	2	Previous Issue:	1	
Issue Date:	November 2000	Previous Issue Date:	October 2000	Daniels Electronics Ltd.
Printing Date:	January 2001			Victoria, BC.
Part No.:	IM20-AP3			PRINTED IN CANADA

Reviewed By:

Quality Assurance:

Larry Freeman
Name

Larry Freeman
Signature

12 May 98
Date

NOTE:

The user's authority to operate this equipment could be revoked through any changes or modifications not expressly approved by Daniels Electronics Ltd.

The design of this equipment is subject to change due to continuous development. This equipment may incorporate minor changes in detail from the information contained in this manual.

TABLE OF CONTENTS

	Page
1	FM AUDIO PROCESSOR 1-1
1.1	Introduction 1-1
1.2	Block Diagram (FM Audio Processor)..... 1-3
1.3	FM Audio Processor Board Pin Connections..... 1-4
1.4	Factory Configuration..... 1-4
1.5	Turn-on Time..... 1-5
1.6	Low Frequency Modulation..... 1-5
1.7	Transmitter Standby Modes..... 1-5
2	SIGNALS..... 2-1
2.1	FM Audio Processor Outputs..... 2-1
2.2	Modulation Output 2-1
2.3	Low Frequency / Direct Mod. Output..... 2-1
2.4	Microphone Input..... 2-1
2.5	Balanced Input..... 2-1
2.6	Auxiliary Input..... 2-2
2.7	Subtone Inputs..... 2-2
2.8	Direct Modulation Input 2-2
3	THEORY OF OPERATION 3-1
4	ALIGNMENT 4-1
4.1	Standard Deviation Adjustment..... 4-1
4.2	Balanced Input Setup..... 4-1
4.3	Microphone Input Setup..... 4-1
4.4	Subtone Input Setup 4-2
4.5	Balanced Input Frequency Response..... 4-2
5	TROUBLESHOOTING - TEST EQUIPMENT NEEDED 5-1
5.1	Balanced Input Test 5-1
5.2	Frequency Response Test..... 5-1
5.3	Subtone Input Test..... 5-2
5.4	Audio benchmarks 5-2
6	TEMPERATURE COMPENSATION 6-1
7	ILLUSTRATIONS, TABLES AND SCHEMATIC DIAGRAMS 7-1
7.1	Special Jumper Configuration Table..... 7-1
7.2	FM Audio Processor Component Layout..... 7-2
7.3	FM Audio Processor Schematic Diagram..... 7-3
8	FM AUDIO PROCESSOR PARTS LIST..... 8-1
9	AM AUDIO PROCESSOR..... 9-5
9.1	Introduction 9-5
9.2	Performance Specifications..... 9-5
9.3	Audio Specifications 9-6

9.4	Audio Circuits.....	9-6
9.5	Power Requirements.....	9-6
9.6	Transmitter Standby Modes.....	9-6
9.7	Audio Circuitry.....	9-7
9.8	AM Audio Processor Factory Configuration.....	9-8
9.9	AM Audio Processor Alignment.....	9-8
9.10	AM Audio Processor Electrical Parts List.....	9-11
9.11	AM Audio Processor Component Layout.....	9-14
9.12	AM Audio Processor Schematic Diagram.....	9-15
10	REVISION HISTORY.....	10-1

LISTS OF FIGURES

Figure 1	Block Diagram - Audio Processor.....	1-3
Figure 2	Pin Connection Diagram.....	1-4
Figure 3	Microphone and Balanced Input Circuitry.....	3-1
Figure 4	Limiter and Splatter Filter.....	3-2
Figure 5	Bypassing Compression.....	3-3
Figure 6	TX Audio Control Circuitry.....	3-4

LIST OF TABLES

Table 1	Bandwidth Definition.....	1-1
Table 2	Factory Configuration.....	1-4
Table 3	Turn On Time.....	1-5
Table 4	Mode Condition Table.....	1-6
Table 5	Standby Mode Selection Table.....	1-6
Table 6	MT-3 Audio Processor Total Current Consumption.....	1-6
Table 7	Operating Current.....	5-1
Table 8	Waveform Levels.....	5-2

1 FM AUDIO PROCESSOR

1.1 Introduction

The MT-3 FM Audio Processor is a versatile circuit board that can provide several types of audio processing for voice or data transmission.

The following terms are defined:

Table 1 Bandwidth Definition

Term	Channel Spacing	Rated System Deviation
Wideband	25 kHz or 30 kHz	± 5.00 kHz
Narrowband	12.5 kHz or 15 kHz	± 2.50 kHz

LTR™ is a trademark of E.F. Johnson Co.

Features include:

- Automatic level control using a compression amplifier with a 25 dB dynamic range
- Limiter and Splatter filter that removes noise and harmonics
- Selectable pre-emphasis or flat audio response
- Temperature compensated audio output
- Ability to transmit data and voice switched by a single control line.
- Backwards compatible with Daniels Electronics MT-2 series transmitters.
- Direct modulation input for LTR™, DCS, paging and other digital modulations that require very low frequency modulation to the synthesizer or crystal oscillator module.
- Separate voice and direct modulation outputs, each individually configurable.
- Multiple jumpers that can be configured to allow maximum flexibility in routing signals from inputs to outputs, and disabling selected circuits to reduce operating current.
- Dual microphone and balanced audio compression circuits.
- On-board multi-configurable temperature compensation to correct for changes in transmitter deviation over temperature caused by changing characteristics of synthesizers and oscillators.
- A single chip 10th Order Linear Phase Lowpass splatter filter for increased cutoff attenuation responses needed in today's narrow band environment.
- The ability to switch between narrow and wideband through a single control line which can be externally controlled. This can be useful when configured as a multi-channel transmitter which uses mixed wide and narrowband frequencies.
- The ability to easily reconfigure fixed operations from narrow to wideband through simple jumper settings

A continuous +9.5 VDC supply and a switched +8.0 VDC supply are required to power the module which is normally supplied by the Main Transmitter Board.

The 6 audio inputs on the FM Audio Processor are:

- DYNAMIC MICROPHONE INPUT
- 600 OHM BALANCED INPUT
- subtone inputs
- auxiliary input.
- direct modulation input for data signals.

The Audio Processor's balanced input pins are isolated by a transformer (T1) on the Transmitter Main Board. Two audio outputs from the MT-3 Audio Processor are routed to the Synthesizer or Crystal Controlled Oscillator Modules.

1.2 Block Diagram (FM Audio Processor)

1.3 FM Audio Processor Board Pin Connections

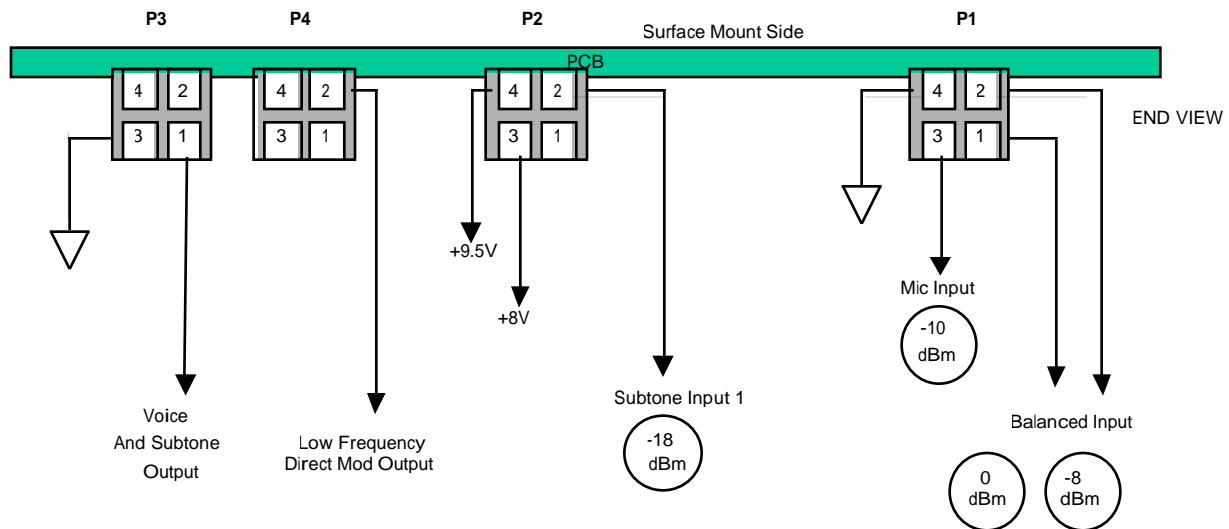

Figure 2 Pin Connection Diagram

1.4 Factory Configuration

The MT-3 FM Audio Processor is factory configured as follows:

Table 2 Factory Configuration

Parameter	Specification
Maximum Deviation	± 2.5 kHz (Narrowband), ± 5.0 kHz (Wideband).
Microphone Input	1 kHz signal at -10 dBm gives $\pm 60\%$ rated system deviation 1 kHz signal compression set at $\pm 84\%$ rated system deviation
Audio Balanced Input pre-emphasis response	1 kHz tone at -8 dBm gives $\pm 60\%$ rated system deviation 1 kHz signal compression set at $\pm 84\%$ rated system deviation
Subtone Input 1	100 Hz tone at -18 dBm gives ± 500 Hz (Wideband) ± 350 Hz (Narrowband) deviation
All other audio inputs	Disabled

1.5 Turn-on Time

This measurement is made with the standard factory settings with a 1 kHz tone applied to the balanced input. The turn-on time is the time it takes the FM Audio Processor to output a stable audio signal to P3-1 from the time its power (+8.0 VDC) is switched on.

The turn-on time can be virtually eliminated by configuring the FM Audio Processor for continuous audio standby (see section 1.7 Transmitter Standby Modes). The drawback is that more current is used to enable the audio circuits to minimize the turn on time. The bulk of the delay is in the powering of the compression amplifier. For applications that do not use the compression amplifier, the fast turn on times apply as in the case of data transmission, or audio with no compression.

Table 3 Turn On Time

Mode	Turn on time	Audio Processor Standby Current
Fast turn on – higher current	Approx 1mS	15 mA
Current save – slower response	Approx 150mS	450uA

1.6 Low Frequency Modulation

The transmitter has an additional option to address low frequency user modulation requirements. A phase modulated bandwidth from 0 (dc) to 100 Hz (PLL loop filter bandwidth) allows specialized applications such as paging or trunking where a separate low frequency digital/analog modulation channel is required. Low Frequency Modulation allows external access to the low frequency modulation capabilities of the synthesizer module. The DIRECT MODULATION inputs on the J1 control connector of the M-3 motherboard will be used (B20 for TX A, and A20 for TX B). Refer to “Data Modulation and Signalling Applications Manual”, P/N AM20-DMS for specific FM Audio Processor configuration methods.

1.7 Transmitter Standby Modes

The MT-3 series transmitters has 8 different standby modes that trade-off standby current consumption for start-up speed.

Three of these jumpers are on the Transmitter Main Board :

- J6 which always turns on the '+9.5 VDC Switched' supply,
- J7 which selects the power source for the MT-3 FM Audio Processor
- J18 which selects the enable line for the OS-3 or OS-3H Synthesizer, or OC-3 Crystal Controlled Oscillator module.

Additionally, there is a jumper on the FM Audio Processor Board:

- JU36 which determines the power hookup for the dual compression amplifiers

Notes:

If FM Audio Processor JU36 is not installed, both microphone and balanced audio compression amplifiers will be disabled. This means that the front panel microphone jack will be disabled for local microphone operations. When in this condition, balanced audio is routed around the compression circuitry via JU11 (installed) with JU1 and JU2 removed.

Table 4 Mode Condition Table

MODE #	J6	J7	J18	Synthesizer/Osc State	Audio Processor State (8V Switched)	Audio Processor Compression JU36
1a	OUT	Y	Y	PTT Switched	PTT Switched	Switched +8.0V(X)
1b	OUT	Y	Y	PTT Switched	PTT Switched	Continuous 9.5V(Y)
1c	OUT	Y	Y	PTT Switched	PTT Switched	Disabled (Not Installed)
2a	IN	Y	X	Always enabled	PTT Switched	Switched +8.0V (X)
2b	IN	Y	X	Always enabled	PTT Switched	Continuous 9.5V (Y)
2c	IN	Y	X	Always enabled	PTT Switched	Disabled (Not Installed)
3	IN	X	Y	PTT Switched	Always enabled	Doesn't matter
4	IN	X	X	Always enabled	Always enabled	Doesn't matter

Table 5 Standby Mode Selection Table

MODE #	Total Xmtr Standby Current		Startup Time	
1a	13 mA	6 mA	150 mS	150 mS
1b	22 mA	15 mA	10 mS	10 mS
1c	13 mA	6 mA	10 mS	10 mS
2a	165 mA	25 mA	150 mS	150 mS
2b	174 mA	34 mA	10 mS	10 mS
2c	165 mA	25 mA	10 mS	10 mS
3	27 mA	20 mA	10 mS	10 mS
4	175 mA	34 mA	10 mS	10 mS

Table 6 FM Audio Processor Total Current Consumption.

Compression configuration	Audio Processor Current Draw keyed / unkeyed
Compression enabled (JU36X)	15 mA/0.45 mA
Compression and microphone disabled (JU36 Open)	9.2 mA/0.45 mA
Compression enabled (JU36Y)	15 mA /9.2 mA

2 SIGNALS

The MT-3 FM Audio Processor has six audio inputs, two audio outputs and one audio control input. Five of the audio inputs are used primarily for voice and tone signals. The sixth, the Direct modulation input, is used primarily for data signals. The audio control input is used to switch audio outputs so the transmitter can transmit voice or data.

2.1 FM Audio Processor Outputs

Both the audio outputs, Modulation Output (P3-1) and Low Frequency / Direct Modulation Output (P4-2), are gated by audio switches U5 and U6 respectively which are controlled by the Transmit Audio Control Input (P4-4). The audio switches can be operated complimentary to each other so there can ever only be one source modulating the transmitter. In standard configuration, the Modulation Output port is used so switch U5 is always on.

2.2 Modulation Output

The Modulation Output port is the output port used by all voice input signals. The voice inputs are passed to U1A and U1B, a dual programmable compandor which is configured as an automatic level control amplifier. Op-amp U3A provides the limiting action for the FM Audio Processor. After the audio signals have been combined limited and buffered, they are filtered by 10th order Linear Phase Lowpass Filter (U4). The output signal from the filter is then level adjusted by the deviation control pot, R29, before buffer amplifier U3D.

In special applications, jumper JU6 can be disabled and JU7 enabled, this allows the transmitter to be modulated directly from the auxiliary input. This should not be done without external filtering since jumper JU7 bypasses the limiting and filter circuits.

2.3 Low Frequency / Direct Mod. Output

The Low Frequency / Direct Modulation Output port has two functions depending on whether the transmitter is synthesized or crystal controlled. In a synthesized transmitter, this port is used to modulate the synthesizer reference frequency. The frequency response of this port is typically DC to 300 Hz. In a crystal controlled transmitter, this port can be used by the Direct Modulation Input to directly modulate the crystal control oscillator module. The frequency response of this port is essentially flat from DC to 5 kHz with no limiting or filtering.

2.4 Microphone Input

The microphone input has an automatically level controlled (ALC) preamplifier U1 whose input level is controlled by R2. The microphone input level control (R2) can accommodate a -25 dBm to 0 dBm input signal. The microphone input is limited and filtered and is output at the standard modulation output port. The microphone input can have a standard 6dB/octave pre-emphasis response or a flat-audio response, jumper JU1 at 'y' and 'x' position respectively.

2.5 Balanced Input

The 600 ohm balanced input uses the ALC preamplifier U1B, with input level control pot (R31). The balanced input level control can accommodate a -25 dBm to 0 dBm input. (install JU17 when

using the lower input levels) Like the microphone input, the balance input is limited and filtered and is output at the standard modulation output port.

If no compression is required (i.e.: customer is providing their own), JU11 can be enabled providing a path through R48 (Auxiliary Input Level Control) to amplifier U2C where pre-emphasis or flat audio can then be selected from its output.

2.6 Auxiliary Input

The auxiliary input is a special input and does not have an ALC. This input can be configured for a pre-emphasis response (enable JU9Y) or a flat-audio response (enable JU9X). The level for this input is set by R48. The auxiliary output is normally summed with the voice signals by op-amp U3A, limited, then filtered and output at the standard modulation output port. When jumper JU6 is disabled and jumper JU7 is enabled, the auxiliary input can be used to directly modulate the transmitter. Care should be taken when directly modulating the transmitter with the auxiliary input because the MT-3 transmitters use direct FM modulation and there is no filtering or limiting action provided by the auxiliary input. The input level to the auxiliary input should be -18 dBm and can be driven by one of three inputs:

- the balanced input – JU11
- the tone/digital input – JU12 X or Y enabled
- the direct modulation input – through JU28

When the 600 ohm balanced input is connected to the auxiliary input, the balanced input level control can be used to adjust the level for the auxiliary input.

2.7 Subtone Inputs

There are two subtone inputs available on the FM Audio Processor. Both subtone inputs can be individually configured to be output from the standard Modulation Output port or to be output from the Low Frequency / Direct Modulation Output. In standard configuration, Subtone 1 is summed with the voice signals to be output from the standard Modulation Output port while Subtone 2 is used for DCS. Both subtone inputs have an input level control.

2.8 Direct Modulation Input

The Direct Modulation Input is an extremely versatile input. This port is designed to be used for data signals. Depending on the application, the signal can be amplified, AC or DC coupled and output to the Modulation Output or the Low Frequency / Direct Modulation Output port. Please consult the factory for specific jumper settings for your application.

3 THEORY OF OPERATION

4 ALIGNMENT

Verify the standard factory settings for the MT-3 FM Audio Processor as given in section 1 before beginning the standard deviation adjustment procedure. If the transmitter's operating frequency is changed beyond the factory recommended bandwidth or if the synthesizer is changed, the FM Audio Processor should be realigned to optimize the transmitter's performance. The schematic diagram for the FM Audio Processor is shown in section 7-2 of this manual.

The settings tolerance is +/- 0.1 kHz.

4.1 Standard Deviation Adjustment

Set up the Communications Analyzer :

- Audio filter to LOW PASS 15 or 20 kHz
- To monitor transmit frequency and audio deviation level.

4.2 Balanced Input Setup

- 1 Connect audio generator output to the BALANCED INPUT (Transmitter Main Board edge connector pins B18, Z18).
- 2 Preset R31 (BALANCED INPUT LEVEL CONTROL)
R38 (COMPRESSION CONTROL)
R29 (DEVIATION CONTROL)
all maximum clockwise
- 3 Set audio generator to 2.4 kHz at 0 dBm.
- 4 Adjust R29 for ± 4.8 kHz (Wideband) or ± 2.4 kHz (Narrowband).
- 5 Set audio generator to 1 kHz at 0dBm
- 6 Set R38 for ± 4.2 kHz (Wideband) or ± 2.1 kHz (Narrowband).
- 7 Repeat steps c) to f) (slight interaction)
- 8 Set audio generator to 1 kHz at -8 dBm
- 9 Adjust R31 for ± 3.0 kHz (Wideband) or ± 1.5 kHz (Narrowband).
- 10 Set audio generator to 1 kHz at -18 dBm
- 11 Ensure deviation is at ± 1.0 kHz (Wideband) or ± 0.5 kHz (Narrowband).
- 12 Set audio generator to 1 kHz at -8 dBm. Set Communications Analyzer Audio Filter to BANDPASS 300-3400 Hz. Activate distortion analyzer. Confirm that the distortion is within specification.

4.3 Microphone Input Setup

1. Set R2 fully clockwise
2. Apply a 1 kHz tone at 0 dBm to the microphone audio input (PIN 1 on the front panel connector. Pin 2 is ground). Set R63 (MICROPHONE COMPRESSION for ± 4.2 kHz (Wideband) or ± 2.1 kHz (Narrowband).
3. Reduce the audio generator level to -10 dBm. Adjust R2 (MICROPHONE INPUT LEVEL) for ± 3.0 kHz (Wideband) or ± 1.5 kHz (Narrowband).

4.4 Subtone Input Setup

- Apply a 100 Hz tone at -18 dBm to the subtone 1 input .
- Adjust R42 (SUBTONE INPUT 1) to produce:
- ± 500 Hz(Wideband) or ± 350 Hz(Narrowband) deviation.
- Remove the signal.

4.5 Balanced Input Frequency Response

- Apply a 1 kHz tone at -18 dBm to the BALANCED INPUT (Transmitter Main Board edge connector pins B18, Z18).
- Record deviation and use this level as the 0 dB reference.
- Sweep frequency from 100 Hz to 5 kHz.
- The audio response should be within +/- 1dB from 300 Hz to 2500 Hz.

5 TROUBLESHOOTING - TEST EQUIPMENT NEEDED

- 1 Variable Power supply/supplies to supply 9.6V and 8.0V at the same time.
- 2 Digital Voltmeter to measure RMS AC Volts, DC Volts, DC Current and resistance.
- 3 20 MHz Oscilloscope, single channel.
- 4 Audio Signal Generator (600 Ohm Output Impedance) capable of frequencies from 67 Hz to 5000 Hz.

Power Supply

- Connect a regulated power supply with +9.5V as follows:
Positive to P2-4
Negative to P1-4 (Ground)
- Connect a regulated power supply with +8.0V as follows:
Positive to P2-3
Negative to P1-4 (Ground)
- Measure total current from both power line inputs:

Table 7 Operating Current

Voltage Input	Current (mA)
8.0V	15.7
9.5V	0.47

5.1 Balanced Input Test

Connect an Audio Generator set for a 2.4 kHz tone @ 0 dBm (775 mV RMS) output to the Balanced Input (P1-1 and P1-2). Refer to Table 8 Waveform Levels for measurement points, levels and waveforms that should be present.

Change Audio Generator settings for a 1 kHz tone @ -8 dBm (309 mV RMS) output. Refer to Table 8 Waveform Levels for levels and waveforms that should be present.

5.2 Frequency Response Test

Reduce Audio Generator level to -18 dBm (98 mV RMS). Step frequency to 500, 1000, 2000 and 3000 Hz. Ensure that the results conform to the 6dB/octave +/- 1 dB from 300 Hz to 2500 Hz referenced to 1000 Hz. Measurements are made at JU8 with respect to ground.

5.3 Subtone Input Test

Change Audio Generator frequency to 100 Hz and maintain level at -18 dBm (98 mV RMS). Connect output to Subtone Input 1 (P2-2) and ground (P1-4). Refer to Table 8 Waveform Levels, for levels and waveforms that should be present.

5.4 Audio benchmarks

Set the audio generator to 2.4 kHz @ 0 dBm at the Balanced Input. Compare the waveform levels with those listed in table below.

Repeat for the various audio frequencies and levels and compare with the levels in the table below.

Table 8 Waveform Levels

	Limiting Test	Std Level	Mic Test	Subtone
Measured @	2.4kHz @0dBm	1 kHz @ -8dBm	1 kHz @ -10 dBm	100 Hz @ -18 dBm
TP3	5.2V P-P	3.8V P-P	N/A	N/A
TP12	N/A	N/A	3.8V P-P	N/A
TP10	6.5V P-P	4.9V P-P	4.8V P-P	1.1V P-P
TP5	2.4V P-P	1.3V P-P	1.9V P-P	0.4V P-P
JU6	5.5V P-P	1.7V P-P	1.8V P-P	0.4V P-P
TP8	1.5V	0.9V P-P	0.9V P-P	0.2V P-P

6 TEMPERATURE COMPENSATION

The FM Audio Processor includes temperature compensation circuitry to maintain constant transmitter audio deviation with a fixed level input signal. It is capable of not only compensating for temperature related level variations within the FM Audio Processor (typically -0.3 to -0.5 dB at -40°C) but can also compensate for changes caused by the synthesizer or crystal oscillator module that is not equipped with its own temperature compensation.

The factory specification is as follows:

Wideband

When a 2.4 kHz tone is applied at a level of -8dBm to the balanced input of the transmitter, the transmitter deviation shall be ± 4.8 kHz at room temperature and can vary from ± 4.5 kHz to ± 5.0 kHz from -40°C to $+60^{\circ}\text{C}$.

Narrowband

When a 2.4 kHz tone is applied at a level of -8 dBm to the balanced input of the transmitter, the transmitter deviation shall be ± 2.4 kHz at room temperature and can vary from ± 2.25 kHz to ± 2.5 kHz from -40°C to $+60^{\circ}\text{C}$.

Since the specifications of the components used in the synthesizer or oscillator may change over time, changes to the temperature compensation circuit may be necessary even for the same type of equipment.

Contact the factory for more information on values used.

This Page Intentionally Left Blank

7 ILLUSTRATIONS, TABLES AND SCHEMATIC DIAGRAMS

7.1 Special Jumper Configuration Table

8 FM AUDIO PROCESSOR PARTS LIST

9 AM AUDIO PROCESSOR

9.1 Introduction

The MT-3 AM Transmitter Main Board integrates the MT-3 Front Panel Board, MT-3 AM Audio Processor, Synthesizer or Crystal Control module and Amplifier module together to make a working MT-3 AM series transmitter. The Front Panel Board and the Audio Processor are soldered directly to the Transmitter Main Board while the Amplifier and the Synthesizer or Crystal Control module are frequency band sensitive, plug-in modules. Circuitry and jumpers on the Transmitter Main Board control the operation of the modules as well as the overall operation of the MT-3 transmitter. Power and signal connections are made to the 48 pin type 'F' connector on the rear of the Transmitter Main Board and are routed to the other modules. The front and rear back plates are attached to the Transmitter Main Board and together with the extruded aluminum shell, as discussed in the assembly section of the Transmitter Manual, form the transmitter enclosure.

9.2 Performance Specifications

Type:	MT-3 AM Series Transmitter
Compatibility:	VT-3A Series Amplifier, OCT-3 Crystal Oscillator, OST-3 Frequency Synthesizer.
Modulation:	6K00A3 (Amplitude Modulation)
Operating Temperature Range:	-30°C to +60°C, optional - 40°C temperature test.
Operating Humidity:	95% RH (non-condensing) at +25°C.
Operating Voltage:	+13.8Vdc , +9.5 Vdc Regulated.
Front Panel Control:	One 3 position switch <ul style="list-style-type: none">• NORM (repeat mode)• OFF• KEY TX
PTT Activation:	<ul style="list-style-type: none">• Active to ground with or without time-out-timer;• Microphone activated with or without time-out-timer;• Front Panel switch: KEY TX - without time-out-timer;• NORM - with or without time-out-timer.• Isolated (optional relay) with or without time-out-timer.
PTT Time-Out-Timer:	Selectable from 1 sec. to 8 hrs. (factory set 5 min.).

9.3 Audio Specifications

Audio Input:	-30 to 0 dBm into a 600Ω balanced load.
Audio Response:	Flat audio; +1/-3 dB: 300 Hz - 3 kHz
Audio Distortion:	Less than 3% -40°C to +60°C at 30% modulation, Less than 5% -40°C to +60°C at 90% modulation

9.4 Audio Circuits

All of the audio signal conditioning (e.g. limiting, filtering) is performed by the MT-3 AM Audio Processor. The transmitter board routes the audio lines from the backplane connector to the audio processor. The audio lines routed to the audio processor are: a 600 ohm balanced input (pins B18 and Z18), and a MIC AUDIO from the MT-3 FRONT PANEL BOARD. It is here that the MIC audio is processed in the same manner as the 600 ohm balanced audio. The audio processor's balanced input pins are isolated from pins B18 and Z18 by a transformer (T1). Two audio outputs from the MT-3 AM Audio Processor are routed to the VT-3A130 Amplifier.

The MT-3 AM Audio Processor is a versatile circuitboard that can provide several types of audio processing. The module also has an on-board programmable push-to-talk (PTT) time-out-timer (TOT) on an attached circuitboard. A continuous +9.5 Vdc supply and a continuous +13.8 Vdc supply together with a switched +8.0 Vdc supply are required to power the module. Refer to section 9.11 "MT-3 AM Audio Processor Component Layout" and to section 9.12 "MT-3 AM Audio Processor Schematic Diagram" for component location and designation references.

9.5 Power Requirements

The audio processor can be configured for continuous audio standby or for switched audio standby by the Transmitter Main Board. If fast audio risetime is desired, the transmitter should be operated in standby mode 3 or 4 as specified below. The current for the associated TOT is approximately 4 mA when the transmitter is keyed.

9.6 Transmitter Standby Modes

The VT-3A130 Transmitter has four different standby modes that trade-off standby current consumption for start-up speed. The standby modes are determined by three jumpers: jumper J6 which always turns on the '+9.5 Vdc Switched' supply, jumper J7 which selects the power source for the MT-3 AM Audio Processor and jumper J18 which selects the enable line for the OST-3A128 Synthesizer Module.

The actual current and start-up time may depend on the frequency controlled source (crystal or synthesizer) and amplifier module. The current and start-up times given below are representative values intended only as a guideline.

MODE 1: Jumper J6 out

- the audio processor is switched by a PTT signal
- the synthesizer is switched by a PTT signal
- standby current typically 13 mA
- start-up time typically 40 ms

MODE 2: Jumper J6 in, jumper J7 in the 'y' position, jumper J18 in the 'x' position

- the audio processor is switched by a PTT signal
- the synthesizer is enabled all of the time
- standby current not used in this mode
- start-up time not used in this mode

MODE 3: Jumper J6 in, jumper J7 in the 'x' position, jumper J18 in the 'y' position

- the audio processor is enabled all of the time
- the synthesizer is switched by a PTT signal
- standby current typically 19 mA
- start-up time typically 40 ms

MODE 4: Jumper J6 in, jumper J7 in the 'x' position, jumper J18 in the 'x' position

- the audio processor is enabled all of the time
- the synthesizer is enabled all of the time
- standby current typically 163 mA
- start-up time typically 12 ms

9.7 Audio Circuitry

The MT-3 AM Tx Audio Processor refer to section 9.12 "MT-3 AM Audio Processor Schematic Diagram" has two audio inputs (Microphone input and Balanced input) which can be used to modulate the transmitter. The input signals are combined by R2 and R17 at a compandor U1. U1b controls the input level and makes gain inversely proportional to the input level (say a 20 dB drop in input level will produced a 20 dB increase in gain). The output will remain fixed at a constant level without clipping and distortion. (Automatic Level Control) The input signals are adjusted by the pots R1, R16. The variable gain cell in U1a is used as a voltage-controlled amplifier so that if the power supply (13.8Vdc) has changed the output level will change in order to keep the modulation of the RF output signal at the same level. The gain control can be adjust by the pot R4. (Automatic Modulation Control) The audio signal then amplifies and filters at U2. The output signal is adjusted by the pot R14.

9.8 AM Audio Processor Factory Configuration

The MT-3 AM Transmitter Audio Processor is factory configured as follows:

- Microphone Input: 1kHz tone at -10 dBm gives 50% maximum modulations.
- Audio Balanced Input: 1 kHz tone at -8 dBm gives 90% maximum modulations.
- Automatic Modulation Control enabled
- Automatic Level Control enabled

The corresponding jumper settings are:

- Jumper JU1: 'x' position Automatic Modulation Control disabled
- Jumper JU2: not installed Modulation configuration
- Jumper JU3: 'y' position Automatic Level Control enabled
- Jumper JU4: not installed Time-out-time power supply (optional)
- Jumper JU5: 'y' position Voice application
- Jumper JU6: 'y' position Voice application
- Jumper JU7: not installed Modulation configuration
- Jumper JU8: 'y' position Automatic Level Control enabled
- Jumper JU9: installed Power AMC and Microphone enabled

9.9 AM Audio Processor Alignment

Verify the standard factory settings for the MT-3 AM Audio Processor as given in section 9.8 before beginning the standard modulation adjustment procedure. If the transmitter's channel frequency changes, the audio processor should be realigned to optimize the transmitter's performance. The schematic diagram for the audio processor is shown in section 9.12 and the component layout is shown in section 9.11.

* Note: clockwise rotation of controls increases signal levels

- 1 Before adjusting the audio board, confirm that the transmitter frequency is correct.
- 2 Unscrew and slide out the case of the transmitter. Locate the Tx Audio Board.
- 3 Connect the transmitter RF Output to a Radio communications test set.
- 4 Connect the 600 ohm input to the incoming audio (pins B18, Z18). Set the audio frequency to 1 kHz at the desired level of -8 dBm.
- 5 Turn the transmitter on.
- 6 Adjust the pot R16, in order to achieve about 0.700 Vrms at TP4.
- 7 Adjust the pot R14, in order to achieve about 0.200 Vrms at TP8.
- 8 Tune the Audio Adjust pot R35 on the Power Amplifier board to obtain 90% modulation.
- 9 Apply a 1 kHz, -20 dBm input signal and adjust the pot R16 in order to obtain 30% modulation.

- 10 Apply a 1 kHz, -8 dBm input signal, the modulation should be 90%, observe that the distortion of the transmitted signal is within 5.0%.
- 11 Slowly increase the input audio signal level to 5 dBm and observe that the modulation does not go over 100%. This step verifies the correct operation of the ALC .
- 12 Change 13.8Vdc power supply to 10V and then to 17V, the modulation of the output RF signal should remain at the same level of 90% \pm 7% and distortion should be less then 3%. This step verifies the correct operation of the power regulator on the transmitter amplifier board.
- 13 Repeat steps 7 and 9 if required.
- 14 Supply a 1 kHz, -10 dBm signal to the microphone input. (Note the level restriction of -25 dBm to 0 dBm.)
- 15 Adjust the Microphone Input Level Adjust pot (R1) to achieve 50% of RF signal modulation. Observe that the distortion should be under 5%.
- 16 Turn off the transmitter. Remove the signal source and replace all the screws.

This Page Intentionally Left Blank

10 REVISION HISTORY

ISSUE	DATE	REVISION
1	Oct 2000	First Issue.
2	Nov 2000	Second Issue Incorporated the AM Audio Processor documentation into this manual. For specific AM revision history, see manual IM22-MT3AMTXMN-4IM

This Page Intentionally Left Blank

**DANIELS
ELECTRONICS LTD. ®**

MT-3 RADIO SYSTEMS

**UHF AMPLIFIER
INSTRUCTION MANUAL
UT-3
406 - 512 MHz**

Covers models:
UT-3/400 Amplifier

Copyright © 1998 Daniels Electronics Ltd. All rights reserved. No part of this publication may be reproduced, stored in a retrieval system or transmitted in any form or by any means, electronic, mechanical, photocopying, recording or otherwise, without the prior written consent of Daniels Electronics Ltd.

Issue: 1 Previous Issue: N/A
Issue Date: May 98 Previous Issue Date: N/A
Printing Date: May 98
Part No.: IM23-UT3400AMP

Daniels Electronics Ltd.
Victoria, B.C.
PRINTED IN CANADA

Reviewed By:

Quality Assurance:

Name

Signature

Date

NOTE:

The user's authority to operate this equipment could be revoked through any changes or modifications not expressly approved by Daniels Electronics Ltd.

The design of this equipment is subject to change due to continuous development. This equipment may incorporate minor changes in detail from the information contained in this manual.

TABLE OF CONTENTS

	Page
1	GENERAL..... 1-1
1.1	Introduction..... 1-1
1.2	Performance Specification..... 1-1
2	THEORY OF OPERATION 2-1
2.1	Amplifier Operation 2-1
2.2	Power Requirements 2-2
2.3	RF Circuitry 2-2
2.3.1	UT-3/400 Lowpass Filter 2-2
2.4	Power Control Circuitry 2-3
2.5	Power Sensing Circuitry 2-3
2.5.1	Output Power Sense..... 2-3
2.5.2	VSWR Sense..... 2-4
2.5.3	VSWR Overload..... 2-4
3	UT-3/400 AMPLIFIER ALIGNMENT..... 3-1
3.1	General..... 3-1
3.2	Repair Note..... 3-1
3.3	Recommended Test Equipment List..... 3-1
3.4	Printed Circuitboard Numbering Convention..... 3-2
3.5	Standard Factory Settings and Jumper Configuration..... 3-2
3.6	UT-3/400 Amplifier Alignment..... 3-2
3.6.1	General..... 3-2
3.6.2	UT-3/400 Amplifier Adjustment 3-3
3.6.2.1	General Set-Up 3-3
3.6.2.2	Output Power Alarm (Forward Power) 3-4
3.6.2.3	Output Power..... 3-5
3.6.2.4	Antenna VSWR Alarm (Reverse Power)..... 3-5
3.6.2.5	Antenna VSWR Overload..... 3-6
3.6.2.6	Procedure Verification..... 3-6
4	ILLUSTRATIONS AND SCHEMATIC DIAGRAMS..... 4-1
4.1	UT-3/400 UHF Amplifier Component Layout..... 4-2
4.2	UT-3/400 UHF Amplifier Schematic Diagram 4-3
4.3	UT-3/400 UHF Lowpass Filter Component Layout 4-5
4.4	UT-3/400 UHF Lowpass Filter Schematic Diagram..... 4-5

5	PARTS LISTS.....	5-1
5.1	UT-3/400 UHF Amplifier Electrical Parts List.....	5-1
5.2	UT-3/400 UHF Amplifier Mechanical Parts List.....	5-4
5.3	UT-3/400 UHF Low Pass Filter Electrical Parts List.....	5-4
6	REVISION HISTORY	6-1

1 GENERAL

1.1 Introduction

The UT-3/400 Amplifier provides the final stage of RF amplification and filtering for the entire UHF Transmitter UT-3 406 -512 MHz family. The amplifier has four distinct frequency ranges: 406 to 430 MHz, 450 to 470 MHz, 470 to 490 MHz and 490 to 512 MHz as well as two distinct output power ranges: 0.5 to 2.0 Watts and 2.0 to 8.0 Watts. The UT-3/400 Amplifier is housed in a machined aluminum case that ensures optimum RF shielding, provides a good ground, and also acts as a heatsink.

Additionally, the UT-3/400 Amplifier is equipped with output power and VSWR sensing lines which can be individually configured as open collector or linear outputs. The internal VSWR sensor protects the amplifier from high antenna VSWR by approximately halving the amplifier's RF gain when a VSWR overload condition is present.

Output filtering for the UT-3/400 Amplifier is provided by the UT-3/400 Lowpass Filter Board. The lowpass filter assembly is mounted in a separate compartment of the amplifier case in order to provided maximum attenuation of harmonic and other spurious signals.

Refer to Section 4 for the UT-3 406 - 512 MHz UHF amplifier and lowpass filter component layouts and schematic diagrams

1.2 Performance Specification

Type:	MT-3 series UHF Amplifier module.
Compatibility:	MT-3 series Transmitter Main Board.
Frequency Range:	406 to 430 MHz, 450 to 470 MHz, 470 to 490 MHz or 490 to 512 MHz.
RF Power Output:	adjustable 0.5 to 2.0 Watts or 2.0 to 8.0 Watts
RF power Input:	nominal level adjustable from +4 dBm to +10 dBm, held within +/- 2 dB of nominal.
Output Impedance and VSWR:	50 Ω , Type N connector; 3:1 max. VSWR.
Input /Output Isolation:	> 60 dB
Duty Cycle:	100%: Continuous operation from -40° C to +60°C.

Harmonic Emissions:	Less than -80 dB _C .
Transmitter Mismatch Protection:	20:1 VSWR at all phase angles.
Transmitter Alarm:	Forward power sense and reverse VSWR; - open collector output (separate or 'OR'ed configuration); -linear output (separate lines only).
Operating Temperature Range:	-30° C to +60° C, optional -40° C temperature test.
Operating Humidity:	95% RH (non-condensing) at +25° C.
Operating Voltage:	+13.8 Vdc Nominal (range +11 to +16 Vdc), +9.5 Vdc Regulated.
Transmit Current:	0.7 Amp typical; 1.1 Amp maximum
Amplifier Standby Current:	less than 0.5 mA.
Amplifier Enable:	Active to ground.
Amplifier Enable Response:	typically overdamped, rising to within 90% of full power within 5 msec; maximum (underdamped) overshoot of 30%.

2 THEORY OF OPERATION

2.1 Amplifier Operation

3 UT-3/400 AMPLIFIER ALIGNMENT

3.1 General

Connections to the power supply, alarm and transmit enable lines (ENA), are clearly marked on the amplifier case. The amplifier is enabled when the enable line (ENA) is grounded.

If the amplifier is installed in the transmitter, alignment is simplified by using an SR-3 Subrack, SM-3 System Monitor, and RF extender cable to provide transmitter power and signal interconnection (see the Transmitter Main Board Manual for details). For complete transmitter alignment, the Transmitter Main Board, Synthesizer, Amplifier, and Audio Processor should be tuned in the aforementioned order. Please refer the corresponding manuals for each module.

If the input RF level is not changed, adjustments to the output power and alarm thresholds may be made without removing the amplifier cover. However, in the case of a complete amplifier alignment, the amplifier should be separated from the Transmitter Main Board and the amplifier cover removed to expose all amplifier circuitry. All jumpers and test points are clearly marked.

3.2 Repair Note

The UT-3/400 Transmitter is mainly made up of surface mount devices which should not be removed or replaced using an ordinary soldering iron. Removal and replacement of surface mount components should be performed only with specifically designed surface mount rework and repair stations complete with ElectroStatic Dissipative (ESD) protection.

When removing Surface Mount Solder Jumpers, it is recommended to use solder braid in place of manual vacuum type desoldering tools when removing jumpers. This will help prevent damage to the circuitboards.

3.3 Recommended Test Equipment List

Alignment of the transmitter requires the following test equipment or its equivalent.

Dual Power Supply:	Regulated +9.5 Vdc at 0.1 A. Regulated +13.8 Vdc at 2 A - Topward TPS-4000
Oscilloscope / Multimeter:	Fluke 97 Scopemeter
Current Meter:	Fluke 75 multimeter
Radio communications test set :	Marconi Instruments 2955R
VSWR 3:1 mismatch load:	JFW 50T-035-3.0:1
coaxial test cable set	three 50 Ω cables of incremental length 20 to 40 cm
Alignment Tool:	Johanson 4192

It is recommended that the radio communications test set be frequency locked to an external reference (WWVH, GPS, Loran C) so that the high stability oscillator may be accurately set to within its ± 1 ppm frequency tolerance.

3.4 Printed Circuitboard Numbering Convention

To ease troubleshooting and maintenance procedures, Daniels Electronics Limited has adopted a printed circuitboard (PCB) numbering convention in which the last two digits of the circuitboard number represent the circuitboard version. For example:

- PCB number 43-912010 indicates circuitboard version 1.0;
- PCB number 50002-02 indicates circuitboard version 2.0.

All PCB's manufactured by Daniels Electronics are identified by one of the above conventions.

3.5 Standard Factory Settings and Jumper Configuration

The UT-3/400 Amplifier is factory configured as follows:

- Open collector configuration for Output Power Alarm (3 dB drop).
- Open collector configuration for Antenna VSWR Alarm ($VSWR \geq 3:1$).
- Output power of 2 Watts or 6 Watts for low and high power amplifiers respectively.

The corresponding jumper settings are:

- | | | |
|---------------|---------------|--|
| • Jumper JU1: | not installed | Output power alarm - linear output |
| • Jumper JU2: | installed | Output power alarm - open collector output |
| • Jumper JU3: | installed | Antenna VSWR alarm - open collector output |
| • Jumper JU4: | not installed | Antenna VSWR alarm - linear output |
| • Jumper JU5: | installed | Low power (2 W) transmitters |
| • Jumper JU5: | not installed | High power (8 W) transmitters |

3.6 UT-3/400 Amplifier Alignment

3.6.1 GENERAL

The UT-3/400 Amplifier is a frequency sensitive module that is factory assembled to operate in one of four frequency bands: 406 to 430 MHz, 450 to 470 MHz, 470 to 490 MHz or 490 to 512 MHz. The amplifier is available in a low power version, 0.5 to 2.0 Watts output power, and a high power version, 2.0 to 8.0 Watts output power. Both amplifier versions require 5 dBm of input power and in both versions the amplifiers output power is continuously adjustable over the its respective power range. The UT-3/400 Amplifier provides Output Power and Antenna VSWR Alarm outputs which can be configured for open collector output or linear operation. The

amplifier's output power level, alarm levels, and tuning for the transistor matching circuit in the high power version can be set without detaching the amplifier from the transmitter board. However, if the output power alarm or the Antenna VSWR alarm output configuration requires changing, the UT-3/400 Amplifier must be detached from the MT-3 Transmitter Board. Refer to section 4 page 2 "UT-3/400 Amplifier Component Layout" for the location of solder jumpers JU1 to JU5.

3.6.2 UT-3/400 AMPLIFIER ADJUSTMENT

The Amplifier alignment consists of two adjustment procedures; (i) a general set up (section 3.6.2.1) procedure which sets up the proper bias conditions for the RF transistors and (ii) the RF threshold adjustments which set up the desired alarm threshold levels as well as the RF output power. The general alignment procedure is required following major repair operations, changes in RF input levels or large changes in operating frequency (greater than ± 1.0 MHz).

The RF output and alarm threshold level adjustments are more easily accessible so that fine adjustments can be made in the field. Depending on user requirements, the RF alarm threshold levels should be checked whenever a significant change in operating frequency (± 0.5 MHz) is made. As the antenna VSWR alarm is dependent on the output power alarm, the output power alarm should always be set first. The order of adjustment should be:

The adjustment procedures for the high power and the low power version amplifiers are identical after the matching for transistor Q1 is tuned in the high power version. As the antenna VSWR alarm is dependent on the output power alarm, the output power alarm should always be set first. The order of adjustment should be:

- 1) High Power Amplifiers Only — Tune the transistor matching circuit at the desired frequency and power.
- 2) Set the desired output power alarm level (section 3.6.2.2).
- 3) Set the desired output power level (section 3.6.2.3).
- 4) Set the desired Antenna VSWR alarm level (section 3.6.2.4).
- 5) Set the desired overload condition level (section 3.6.2.5).

Details for the preceding four steps are outlined below.

3.6.2.1 General Set-Up

- 1 Connect the transmitter's antenna output connector to the type N input of the radio communications test set through a short section of low loss 50Ω coaxial cable.
- 2 Turn all four (4) of the adjustment potentiometers (R7, R21, R36, and R38) fully counterclockwise.

- 3 Turn on the power to the transmitter.
- 4 For high power amplifier units, follow steps 5 to 7 below. For low power amplifiers, skip to the Output Power Alarm procedure.
- 5 Tune the output matching capacitor for maximum output power. This should be approximately 8 Watts.
- 6 For single frequency applications, tune the input matching capacitor so that +9.5 Vdc current is minimized without sacrificing output power. For wideband applications it is best to tune the amplifier at the highest frequency in the band of interest and then tune the input matching capacitor so that the +9.5 Vdc current never exceeds 1.2 amps over the desired frequency band.
- 7 For single frequency applications, re-peak the output matching capacitor. For wideband applications it is best to tune the amplifier at the highest frequency in the band of interest and then re-peak the output matching capacitor so that the +13.8 Vdc current never exceeds 1.5 amps over the desired frequency band.

3.6.2.2 Output Power Alarm (Forward Power)

Open Collector Output

* note: the output power alarm output is factory configured as an open collector output so a pull-up resistor may be required on transmitter pin B26 if one is not already present.

- 1 Adjust R7, the output power adjustment, to the output power at which the Output Power Alarm is to be activated.
- 2 Monitor transmitter pin B26, the Output Power Alarm line, and slowly turn R21, the output power alarm adjustment, clockwise until pin B26 goes low. The alarm is now set for the current output power of the transmitter.

Linear Output

- 1 Open the amplifier case to disable (open circuit) jumper JU2 and enable (short) jumper JU1.
- 2 Monitor transmitter pin B26 with a voltmeter.
- 3 Adjust R7, the output power adjustment, for full transmitter output power.

- 4 Adjust R21, the output power alarm adjustment, so that the voltmeter indicates +7.5 Vdc for full transmitter output power.
- 5 Turn R7, the output power adjustment, fully counterclockwise. The voltmeter should read approximately +3 Vdc.
- 6 Disconnect the voltmeter.

3.6.2.3 Output Power

- 1 Turn R7, the output power adjustment, clockwise to the desired transmitter output power.

3.6.2.4 Antenna VSWR Alarm (Reverse Power)

Open Collector Output

* note: the antenna VSWR alarm output is factory configured as an open collector output so a pull-up resistor may be required on transmitter pin Z26 if one is not already present. The output power alarm must be set first before the antenna VSWR alarm can be set.

- 1 Disconnect the radio communications test and terminate the transmitter with the 3:1 mismatch load.
- 2 Monitor pin Z26, the Antenna VSWR Alarm line, and turn R36 fully counterclockwise. Pin Z26 should be high. Slowly turn R36 clockwise until pin Z26 is pulled low. Put the 50 ohm load back on again, Pin Z26 should go high. The reverse power trip point is now set for a VSWR of 3:1.

Linear Output

- 1 Open the amplifier case to disable (open circuit) jumper JU3 and enable (short) jumper JU4.
- 2 Monitor transmitter pin Z26 with a voltmeter.
- 3 Disconnect the radio communications test set and terminate the transmitter with the 3:1 mismatch load.
- 4 Adjust R36, the VSWR alarm adjustment, so that the voltmeter indicates +5 Vdc for a 3:1 mismatch.

- 5 Put the 50 ohm load back on again. The voltmeter should read approximately 0 Vdc.
- 6 Disconnect the voltmeter.

3.6.2.5 Antenna VSWR Overload

- 1 Disconnect the radio communications test set and so that the amplifier is terminated with an open circuit.
- 2 Monitor the current from the +9.5 Vdc supply.
- 3 Adjust R38, the VSWR overload adjustment, clockwise until a noticeable drop in the +9.5 Vdc current occurs.
- 4 Reconnect the radio communications test set and, the +9.5 Vdc current should return to the previous level.

3.6.2.6 Procedure Verification

- 1 Verify that the current drawn from the +13.8 Vdc supply is less than 1.5 A and from the +9.5 Vdc supply is less than 1.2 A when transmitting full 8 W RF output power.
- 2 Turn off the power to the transmitter.

4 ILLUSTRATIONS AND SCHEMATIC DIAGRAMS

This Page Intentionally Left Blank

5 PARTS LISTS

5.1 UT-3/400 UHF Amplifier Electrical Parts List

NOTE: Reference Designators labeled with an asterisk (*) are used only in 2.0 - 8.0 Watts amplifiers.

6 REVISION HISTORY

ISSUE	DATE	REVISION
-------	------	----------

1	JUL 97	First Issue.
---	--------	--------------



MT-3 RADIO SYSTEMS

ENHANCED AM/FM SYNTHESIZER INSTRUCTION MANUAL OS(R/T)-3(A/H) 29 - 470 MHz

Covers models:

OST-3H035, OST-3H045, OSR-3H061
OST-3A128, OSR-3A149
OST-3H141, OST-3H162, OSR-3H141, OSR-3H162
OST-3H440, OSR-3H440

Copyright © 2000 Daniels Electronics Ltd. All rights reserved. No part of this publication may be reproduced, stored in a retrieval system or transmitted in any form or by any means, electronic, mechanical, photocopying, recording or otherwise, without the prior written consent of Daniels Electronics Ltd.

DE™ is a registered trademark of Daniels Electronics Ltd. registered in the United States Patent and Trademark Office.

Issue:	4	Previous Issue:	3	Daniels Electronics Ltd. Victoria, BC. PRINTED IN CANADA
Issue Date:	September 2000	Previous Issue Date:	March 2000	
Printing Date:	January 2001			
Part No.:	IM10-OS3AH			

Reviewed By:

Quality Assurance:

Larry Freeman
Name

Larry Freeman
Signature

12 May 98
Date

NOTE:

The user's authority to operate this equipment could be revoked through any changes or modifications not expressly approved by Daniels Electronics Ltd.

The design of this equipment is subject to change due to continuous development. The equipment covered by this manual may incorporate minor changes in detail from the information contained in this manual.

TABLE OF CONTENTS

	Page
1 GENERAL.....	1-1
1.1 Introduction	1-1
1.2 OS(R/T)-3(A/H) Enhanced Synthesizer Family Models	1-1
1.3 Performance Specifications.....	1-3
1.4 Printed Circuit Board Numbering Convention.....	1-5
2 THEORY OF OPERATION.....	2-1
2.1 Internal Power and Control (Digital Board).....	2-1
2.2 Synthesizer Analog Circuitry (Analog Board)	2-1
2.2.1 Common Analog Board Circuitry	2-1
2.2.2 29 - 71.4 MHz Analog Board Circuitry	2-3
2.2.3 118 - 159.4 MHz Multichannel AM Analog Board Circuitry.....	2-3
2.2.4 128 - 174 MHz Analog Board Circuitry	2-4
2.2.5 406 - 470 MHz Analog Board Circuitry	2-5
2.3 Synthesizer Digital Circuitry (Digital Board).....	2-6
2.4 Frequency Control.....	2-6
2.4.1 BCD Switch Frequency Control.....	2-6
2.4.2 Frequency Select Handle Frequency Control.....	2-7
2.5 Synthesizer Base and Frequency Increment Table.....	2-7
2.6 5.0/6.25 kHz Channelization.....	2-8
2.7 8.333 kHz Channelization.....	2-8
2.8 12.5 kHz Channelization.....	2-9
3 SYNTHESIZER ALIGNMENT.....	3-1
3.1 General.....	3-1
3.2 Repair Note.....	3-1
3.3 Recommended Test Equipment.....	3-1
3.4 OS(R/T)-3(A/H) Synthesizer Factory Configuration.....	3-1
3.5 OS(R/T)-3(A/H) Synthesizer Alignment	3-2
3.5.1 General.....	3-2
3.5.2 Synthesizer Test Points.....	3-2
3.5.3 Synthesizer Removal and Installation.....	3-3
3.5.4 Circuit Board Removal.....	3-3
3.5.5 Frequency Adjustment and Channel Selection.....	3-3
3.5.5.1 VHF OS(R/T)-3H 29 - 71.4 MHz VCO Alignment.....	3-4
3.5.5.2 VHF OS(R/T)-3A 118 - 159.4 MHz Alignment.....	3-5
3.5.5.3 VHF OS(R/T)-3H 128 - 174 MHz VCO Alignment.....	3-5
3.5.5.4 UHF OS(R/T)-3H 406 - 470 MHz VCO Alignment.....	3-6
3.5.5.5 Reference Frequency Alignment.....	3-6
3.5.6 Jumper Configuration.....	3-7

4	ILLUSTRATIONS AND SCHEMATIC DIAGRAMS	4-1
4.1	OS(R/T)-3H 29 - 71.4 MHz Analog Board Diagrams	4-1
4.1.1	OS(R/T)-3H 29 - 71.4 MHz Analog Board Component Layout (Bottom)	4-1
4.1.2	OS(R/T)-3H 29 - 71.4 MHz Analog Board Component Layout (Top)	4-2
4.1.3	OS(R/T)-3H 29 - 71.4 MHz Analog Board Schematic Diagram.....	4-3
4.2	OS(R/T)-3A 118 - 159.4 MHz Analog Board Diagrams.....	4-5
4.2.1	OS(R/T)-3A 118 - 159.4 MHz Analog Board Component Layout (Bottom)	4-5
4.2.2	OS(R/T)-3A 118 - 159.4 MHz Analog Board Component Layout (Top)	4-6
4.2.3	OS(R/T)-3A 118 - 159.4 MHz Analog Board Schematic Diagram....	4-7
4.3	OS(R/T)-3H 128 - 174 MHz Analog Board Diagrams	4-9
4.3.1	OS(R/T)-3H 128 - 174 MHz Analog Board Component Layout (Bottom)	4-9
4.3.2	OS(R/T)-3H 128 - 174 MHz Analog Board Component Layout (Top)	4-10
4.3.3	OS(R/T)-3H 128 - 174 MHz Analog Board Schematic Diagram.....	4-11
4.4	OS(R/T)-3H 406 - 470 MHz Analog Board Diagrams	4-13
4.4.1	OS(R/T)-3H 406 - 470 MHz Analog Board Component Layout (Bottom)	4-13
4.4.2	OS(R/T)-3H 406 - 470 MHz Analog Board Component Layout (Top)	4-14
4.4.3	OS(R/T)-3H 406 - 470 MHz Analog Board Schematic Diagram.....	4-15
4.5	OS(R/T)-3(A/H) Digital Board Diagrams	4-17
4.5.1	OS(R/T)-3(A/H) Digital Board Component Layout (Bottom).....	4-17
4.5.2	OS(R/T)-3(A/H) Digital Board Component Layout (Top)	4-18
4.5.3	OS(R/T)-3(A/H) Digital Board Schematic Diagram.....	4-19
5	PARTS LISTS	5-1
5.1	OS(R/T)-3H 29 - 71.4 MHz Analog Board Electrical Parts List	5-1
5.2	OS(R/T)-3A 118 - 159.4 MHz Analog Board Electrical Parts List.....	5-5
5.3	OS(R/T)-3H 128 - 174 MHz Analog Board Electrical Parts List	5-8
5.4	OS(R/T)-3H 406 - 470 MHz Analog Board Electrical Parts List	5-11
5.5	OS(R/T)-3(A/H) Digital Board Electrical Parts List	5-14
5.6	OS(R/T)-3(A/H) Synthesizer Mechanical Parts List.....	5-15
6	REVISION HISTORY.....	1

1. GENERAL

1.1 Introduction

The OS-3A/H Synthesizer is a compact, fully shielded and environmentally rugged frequency synthesis module that is the nucleus of every MT-3 synthesized Receiver and Transmitter radio module. The OS-3A/H generates a high stability, low distortion radio frequency signal in one of several frequency bands, including 29 - 50 MHz, 118 - 159.4 MHz, 118 - 174 MHz and 406 - 470 MHz. The OS-3A/H utilizes an internal temperature compensated 9.6 MHz reference to produce a signal stable to ± 1 ppm within the temperature range of -40°C to $+60^{\circ}\text{C}$. Alternately, the OS-3A/H can be disciplined by an external 9.6 MHz or 10 MHz reference of higher stability. The OS-3A/H Synthesizer Module is manufactured in twelve distinct models which cover three primary frequency bands (see section 1.2 below). All synthesizer modules are designed to be easily removed for programming, calibration and/or repair. The synthesizer circuitry is distributed between two printed circuit boards (PCBs) which are isolated yet interconnected via photo-logic optical transceivers that effectively eliminate residual electrical noise between digital and analog circuitry. Further shielding of the synthesizer's RF filter circuitry is provided by an internal shielded enclosure.

1.2 OS(R/T)-3(A/H) Enhanced Synthesizer Family Models

The OS-3A/H Synthesizer Module is utilized in both the MT-3 Receiver and Transmitter product lines. In MT-3 Transmitters, the OS-3A/H synthesizer provides a modulated, low-level RF signal to the Power Amplifier module. In MT-3 Receivers, the OS-3A/H synthesizer provides a low noise local oscillator (LO) signal that either directly drives the mixer circuitry or first drives a buffer amplifier which precedes the mixer circuitry (if a higher LO drive signal is required for enhanced intermodulation capability). There are twelve distinct models within the OS-3A/H Enhanced Synthesizer Family. Note that this manual provides service and operating information for all twelve synthesizer modules. It is extremely important to establish the correct synthesizer model number, as documentation is model-specific. The model number can be found on the synthesizer label, located on the synthesizer module top cover.

The twelve synthesizer models that comprise the OS-3A/H Synthesizer family are follows:

Frequency Band: 29 - 50 MHz, Common OS-3H0xx Analog Board

- OST-3H035 - installed in FM transmitter, 29 - 38 MHz RF output.
- OST-3H045 - installed in FM transmitter, 38 - 50 MHz RF output.
- OSR-3H061 - installed in FM receiver, 50.4 - 71.4 MHz RF output.

Frequency Band: 118 - 159.4 MHz, AM Multichannel OS-3H1xx Analog Board

- OST-3A128 - installed in AM transmitter, 118 - 138 MHz RF output.
- OSR-3A149 - installed in AM receiver, 139.4 - 159.4 MHz RF output.

Frequency Band: 128 - 174 MHz, Common OS-3H1xx Analog Board

- OST-3H141 - installed in FM transmitter, 128 - 152.6 MHz RF output.
- OST-3H162 - installed in FM transmitter, 150 - 174 MHz RF output.
- OSR-3H141 - installed in FM receiver, 128 - 152.6 MHz RF output.
- OSR-3H162 - installed in FM receiver, 150 - 174 MHz RF output.

Frequency Band: 406 - 470 MHz, Common OS-3H4xx Analog Board

- OST-3H418 - installed in FM transmitter, 406 - 430 MHz RF output.
- OST-3H460 - installed in FM transmitter, 450 - 470 MHz RF output
- OSR-3H440 - installed in FM receiver, 427.4 - 451.4 MHz RF output.

All OS-3A/H Enhanced Synthesizer Modules, regardless of the frequency band, use the same digital PCB and mechanical construction. There are, however, significant differences between the various models when it comes to the analog PCB. There are four different analog PCBs, designed to cover the four frequency bands of 29 - 50 MHz, 118 - 159.4 MHz, 128 - 174 MHz and 406 - 470 MHz. Each model's specific sub-band of operation within a given frequency band is determined through SELECT components on the corresponding analog board.

1.3 Performance Specifications

Type: Narrow band FM, Single loop synthesizer module utilizing low noise VCO and PLL technology.
Compatible with Daniels MT-3 series Transmitter and Receiver modules.

Frequency Range: 29 MHz - 38 MHz [± 0.5 MHz] (OST-3H035)
(Tuning range with no adjustment 38 MHz - 50 MHz [± 1.0 MHz] (OST-3H045)
is shown in [] brackets.) 50.4 MHz - 71.4 MHz [± 1.0 MHz] (OSR-3H061)

118 MHz - 138 MHz [Full band] (OST-3A128)

128 MHz - 152.6 MHz [± 2.0 MHz] (OST-3H141, OSR-3H141)

139.4 MHz - 159.4 MHz [Full band] (OSR-3A149)

150 MHz - 174 MHz [± 2.0 MHz] (OST-3H162, OSR-3H162)

406 MHz - 430 MHz [Full band] (OST-3H418)

427.4 MHz - 451.4 MHz [Full band] (OSR-3H440)

450 MHz - 470 MHz [Full band] (OST-3H460)

Output Power: +5 dBm ± 2 dBm into 50 Ω

Harmonics: <-30 dBc

Spurious: <-90 dBc

<-70 dBc above 400 MHz

Attack Time: <10 ms (Normal Mode)

<50 ms (Low Current Standby Mode)

Hum and Noise: -55 dB

Modulation Sensitivity: 3.0 kHz peak deviation (400 mVrms input)

External Reference Input: External reference input signal via SMB connector J1

Input level 0 dBm \pm 3 dB

Input impedance 50 Ω

Input frequency 10.0 MHz or 9.6 MHz (selectable through digital board jumper JU1)

Power Requirements: Normal Configuration:

+9.5 Vdc @ 160 mA for FM and 65 mA for AM

Low Current Standby Mode (TCXO enabled):

+9.5 Vdc @ 14 mA for FM and 4 mA for AM

1.4 Printed Circuit Board Numbering Convention

To expedite troubleshooting and maintenance procedures, Daniels Electronics Ltd. has adopted a printed circuit board (PCB) numbering convention in which the last two digits of the circuit board number represent the circuit board version. All PCB's manufactured by Daniels Electronics Ltd. are identified by one of the following numbering conventions:

- PCB number 43-912010 indicates circuit board version 1.0; or
- PCB number 50002-02 indicates circuit board version 2.0

This Page Left Intentionally Blank

2. THEORY OF OPERATION

2.1 Internal Power and Control (Digital Board)

3. SYNTHESIZER ALIGNMENT

3.1 General

OS(R/T)-3(A/H) enhanced synthesizer alignment is simplified by using a Type 84 subrack and RF extender card/cable of providing receiver or transmitter power and signal interconnection. Alternately, +9.5 Vdc may be directly connected to a receiver or transmitter module with the positive connection on pins B6 / Z6 and the negative connection on pins B30 / Z30 / B32 / Z32. Receiver balanced audio (600 Ω) is available at pins B26 and Z26.

3.2 Repair Note

The OS(R/T)-3(A/H) synthesizer employs a large number of surface mount components. Removal and/or replacement of surface mount components should never be performed using an ordinary soldering iron but should only be performed at surface mount rework and repair stations equipped with Electro Static Dissipative (ESD) protection.

When removing Surface Mount Solder Jumpers, it is recommended that solder wick braid be used in lieu of vacuum type de-soldering tools to help prevent damage to the printed circuit boards.

3.3 Recommended Test Equipment

Alignment of the synthesizer requires the following test equipment, or its equivalent:

Power supply - Regulated +9.5 Vdc at 2 A. Phillips PM 2811

Oscilloscope / Multimeter - Fluke 97 Scopemeter

Radio communications test set - Marconi Instruments 2965A

It is recommended that the radio communications test set be referenced to an external high stability frequency source (WWVH, GPS, Loran C) so that the OS-3A/H internal high stability local oscillator may be accurately set to within its ± 1 ppm frequency tolerance.

3.4 OS(R/T)-3(A/H) Synthesizer Factory Configuration

The OS(R/T)-3(A/H) Synthesizer is factory configured as follows:

- Internal 9.6 MHz reference selected.
- VCO modulation (via audio processor) enabled (OST TX versions only)

The corresponding internal synthesizer jumper settings are:

- | | | |
|---------------|---------------|---|
| Digital Board | | |
| • Jumper JU2 | not installed | 9.6 MHz internal frequency reference selected |
| • Jumper JU1 | installed | AM Multichannel mode selected |
| Analog Board | | |
| • Jumper JU1: | 'B' position | Internal frequency reference selected |
| • Jumper JU2 | not installed | Internal frequency reference selected |

3.5 OS(R/T)-3(A/H) Synthesizer Alignment

3.5.1 General

Under normal circumstances (i.e. a change in operating frequency within the synthesizer's maximum tuning range), synthesizer alignment is accomplished with the synthesizer installed in the MT-3 Receiver IF/Audio Board or the MT-3 Transmitter Main Board. The alignment procedure involves setting the internal TCXO reference frequency (if one is installed and the internal reference option is enabled). This step is described in "[Reference Frequency Alignment](#)", [section 3.5.5.5](#). A change in operating frequency from the initial factory setting that exceeds the synthesizer's maximum tuning range ([Refer to Specifications section 1.3](#)) requires a more involved [alignment procedure as described in sections 3.5.2 to 3.5.5](#). Conversion of a synthesizer from internal reference to external reference or vice-versa is accomplished through selection of jumper JU1 A or B, as appropriate and JU2 ([Refer to section 3.5.6](#)).

3.5.2 Synthesizer Test Points

Analog Board Component Layout (Top)

Common to all synthesizer family members.

- TP1 +8.0 \pm 0.3 Vdc. U6 positive regulator output.
- TP2 +5.0 \pm 0.1 Vdc. U7 positive regulator output.
- TP3 +5.0 \pm 0.1 Vdc. U8 positive regulator output (always on).
- TP4 PLL error voltage. Normal range is +0.5 to +4.5 Vdc (depending on frequency).
Nominally adjusted for +2.3 Vdc (via C24) for center channel.
UHF/VHF versions employing integrated VCO modules (OSR-3H440, OST-3H418, OST-3H460, OSR-3A149, OST-3A128) require no adjustment.

Digital Board Component Layout (Bottom)

- TP1 +5.0 \pm 0.1 Vdc. U2 positive regulator output (controlled via pin P2-4).
- TP2 Microcontroller E clock. 2 MHz logic level square wave.

3.5.3 Synthesizer Removal and Installation

The synthesizer module is secured to the main board (MT-3 Receiver IF/Audio Board or MT-3 Transmitter Main board) with a single counter sunk Phillips machine screw accessible from the top cover. Remove this screw to remove the synthesizer module. Using a plastic coated lifting tool, such as a small screwdriver with the tip covered in heat shrink material, gently lift the synthesizer module from the main circuit board by applying pressure in a rotating fashion about the four corners of the synthesizer module. It is important to gently remove the synthesizer module "straight out" in order to prevent damage to the connector pins. Installation of the synthesizer is performed in a reverse fashion. It is important to ensure complete connector pin alignment prior to any application of reinsertion force. Four corner locating pins on the synthesizer housing assist in connector pin alignment during installation and removal.

Note: Complete synthesizer alignment can be performed without removing the synthesizer.

The alignment procedure starting in section 3.5.5 may now be performed.

3.5.4 Circuit Board Removal

Note: Circuit board removal is not required for tuning purposes.

Using a vacuum de-soldering station, de-solder connections P1, P2 and P3. Remove SMB connectors J1 and J2 by de-soldering the center pins and removing four M2.0 machine screws. These connection points are shown in the "OS(R/T)-3(A/H) XXX - XXX MHz Analog Board Component Layout (Top)" diagrams. Remove seven M2.0 machine screws and carefully remove the analog circuit board. Removal of the analog circuit board will expose three inter-board wire connections. Carefully remove three ferrite beads and six Teflon washers from the inter-board connection wires. Attempt to maintain the position of the three inter-board wires in order to simplify re-assembly. The digital board may now be extracted by removing four M2.0 machine screws. Follow a reverse procedure to re-assemble.

3.5.5 Frequency Adjustment and Channel Selection

Connect a radio communications test set through a short section of low loss 50 Ω coaxial cable to the synthesizer module SMB RF output jack (J2). Select the desired channel number via the BCD frequency selection switches on the MT-3 Transmitter Main board or the MT-3 Receiver IF/Audio board (or through the Frequency Programming Module). Turn the power off and back on and wait a few minutes for the oscillator to completely stabilize. It should be noted that the internal synthesizer TCXO, if installed, operates continuously (regardless of the TX PTT state) when installed in a transmitter.

The measured RF output signal should be within ± 1.0 ppm of the specified oscillator frequency at an output level of +5 dBm. Note that unlocked synthesizer operation will be indicated by an unstable or spurious RF output signal. The "Unlocked" red LED will also be illuminated when the PLL is unlocked. Check that the requested channel number is within the frequency range of the particular synthesizer model. An unlocked condition may be rectified by adjusting the VCO tuning elements as described in the following procedures (no adjustment required for the Multichannel AM Synthesizers). Note that there are variations in alignment procedures between the three synthesizer family members as described in the following sections.

3.5.5.1 VHF OS(R/T)-3H 29 - 71.4 MHz VCO Alignment

Refer to the "OS(R/T)-3H 29 - 71.4 MHz Analog Board Component Layout" diagrams and the "OS(R/T)-3H 29 - 71.4 MHz Analog Board Schematic Diagram" on pages 4-1, 4-2 and 4-3 of this manual.

Using a high impedance (10 M Ω) DC Voltmeter, measure the PLL control voltage at TP4 located on the synthesizer module analog board (top). Access to TP4 is available through the synthesizer top cover. Using a small standard blade screwdriver, carefully adjust the VCO fine frequency "TUNE" trimmer capacitor C24 until a test point (TP4) voltage of approximately +2.3 Vdc is obtained. PLL loop control voltages below approximately +0.5 Vdc and above approximately +4.5 Vdc will indicate an "out of lock" synthesizer condition.

If a test point (TP4) reading of approximately +2.3 Vdc is unattainable through adjustment of C24, then the coarse frequency jumpers, JU2-JU4 require modification in order to pull the VCO tune range within the adjustment range of fine tuning capacitor C24. The top synthesizer cover must be removed in order to gain access to the coarse frequency jumpers. The coarse frequency jumpers (JU2-JU4) may be considered to be a selectable binary weighted capacitor element with JU2 being the most significant "bit" and JU4 being the least significant "bit". The tuning resolution size is ≈ 12 pF (JU4). If the tuning voltage remains higher than +2.3 Vdc, decrease the tuning jumper setting by 1 "bit" position and re-adjust C24 in an attempt to achieve +2.3 Vdc at TP4. For example, if coarse frequency jumpers JU2-JU4 are all installed and represented by 111 then a decrease by 1 "bit" position (12 pF) is represented by a binary jumper selection of 110; jumper JU4 is not installed and jumpers JU2, JU3 are installed. Continue to decrease the jumper position one "bit" at a time until the synthesizer regains lock with TP4 adjusted (C24) for +2.3 Vdc. If the tuning voltage remains lower than +2.3 Vdc, increase the jumper setting by 1 "bit" position and re-adjust C24 in an attempt to achieve +2.3 Vdc at TP4. Repeat this procedure until +2.3 Vdc is achieved at TP4.

It is important to check the loop control voltage at TP4 when multiple synthesizer channels have been programmed. All channel selections should result in a TP4 voltage within a +1.0 to +4.0 Vdc range. Adjust the fine-tuning capacitor C24 to center multiple channel voltages symmetrically about +2.3 Vdc. Channel selections beyond the tuning range capability of the synthesizer will result in

unlocked operation. The tuning range capability of all synthesizer models is listed in the Specifications section (1.3) of this manual.

3.5.5.2 VHF OS(R/T)-3A 118 - 159.4 MHz Alignment

Refer to the "OS(R/T)-3A 118 - 159.4 MHz Analog Board Component Layout" diagram and the "OS(R/T)-3A 118 - 159.4 MHz Analog Board Schematic Diagram" on pages 4-5, 4-6 and 4-7 of this manual.

Using a high impedance (10 M Ω) DC Voltmeter, measure the PLL control voltage at TP4 located on the synthesizer module analog board (top). Access to TP4 is available through the synthesizer top cover. VHF synthesizers operating in the 118 - 159.4 MHz frequency range require no frequency adjustment as tuning is microprocessor controlled. (The OST-3A128 and OSR-3A149, covering 118-138 MHz and 139.4 - 159.4 MHz respectively, provide full band coverage without tuning adjustment.)

All channel selections should result in a TP4 voltage between +3.1 and +3.5 Vdc. Channel selections beyond the tuning range capability of the synthesizer will result in unlocked operation over the temperature range -40C to +60C. The tuning range capability of all synthesizer models is listed in the Specifications section of this manual.

3.5.5.3 VHF OS(R/T)-3H 128 - 174 MHz VCO Alignment

Refer to the "OS(R/T)-3H 128 - 174 MHz Analog Board Component Layout" diagram and the "OS(R/T)-3H 128 - 174 MHz Analog Board Schematic Diagram" on pages 4-9, 4-10 and 4-11 of this manual.

Using a high impedance (10 M Ω) DC Voltmeter, measure the PLL control voltage at TP4 located on the synthesizer module analog board (top). Access to TP4 is available through the synthesizer top cover. Using a small standard blade screwdriver, carefully adjust the VCO fine frequency "TUNE" trimmer capacitor C24 until a test point (TP4) voltage of approximately +2.3 Vdc is obtained. Measured PLL loop control voltages below approximately +0.5 Vdc and above approximately +4.5 Vdc will indicate an "out of lock" synthesizer condition.

It is important to check the loop control voltage at TP4 when multiple synthesizer channels have been programmed. All channel selections should result in a TP4 voltage within the +1.0 to +4.0 Vdc range. Adjust the fine-tuning capacitor C24 to center multiple channel voltages symmetrically about +2.3 Vdc. Channel selections beyond the tuning range capability of the synthesizer will result in unlocked operation. The tuning range capability of all synthesizer models is listed in the Specifications section of this manual.

3.5.5.4 UHF OS(R/T)-3H 406 - 470 MHz VCO Alignment

Refer to the "OS(R/T)-3H 406 - 470 MHz Analog Board Component Layout" diagram and the "OS(R/T)-3H 406 - 470 MHz Analog Board Schematic Diagram" on pages 4-13, 4-14 and 4-15 of this manual.

Using a high impedance (10 M Ω) DC Voltmeter, measure the PLL control voltage at TP4 located on the synthesizer module analog board (top). Access to TP4 is available through the synthesizer top cover. The UHF synthesizers operating in the 406 - 470 MHz frequency range employ integrated VCO modules having no external frequency adjustment capability. The OST-3H418, OST-3H460 and OSR-3H440 models cover frequencies from 406 - 430 MHz, 450 - 470 MHz and 427.4 - 451.4 MHz respectively and provide full band coverage without tuning adjustment. For the OST-3H418, measured PLL control voltages below approximately +0.5 Vdc and above approximately +4.5 Vdc will indicate an "out of lock" condition. For the OSR-3H440 and the OST-3H460, measured PLL control voltages below approximately +1.0 Vdc and above approximately +7.0 Vdc will indicate an "out of lock" condition.

It is important to check the loop control voltage at TP4 when multiple synthesizer channels have been programmed. All channel selections should result in a TP4 voltage within the +0.5 to +4.5 Vdc range for the OST-3H418. The TP4 voltage for the OSR-3H440 and the OST-3H460 should be within the +1.0 to +7.0 Vdc range. Channel selections beyond the tuning range capability of the synthesizer will result in unlocked operation. The tuning range capability of all synthesizer models is listed in the Specifications section of this manual.

3.5.5.5 Reference Frequency Alignment

Adjust the synthesizer TCXO fine frequency potentiometer RV1 until the correct output frequency is achieved. Access to this potentiometer is through an opening in the synthesizer top cover. A RF power level of approximately +5 dBm should be measured at the synthesizer module output connector and the frequency should be within ± 1 ppm of the desired operating frequency. Reference frequency adjustments should be made at room temperature (+25°C) after a ten minute stabilization period.

3.5.6 Jumper Configuration

Solder jumpers are clearly marked on both synthesizer digital and analog circuit boards. Refer to the "OS(R/T)-3(A/H) Digital Board Component Layout (Bottom)" diagram on page 4-17 of this manual and the applicable "OS(R/T)-3(A/H) Analog Board Component Layout (Top)" diagram on page 4-18 for jumper locations. The following list details the required jumper configuration for the two synthesizer operating modes:

- 1) Internal reference. Install jumper JU1-B, on the Analog Board (Standard). The internal temperature compensated crystal oscillator (TCXO) provides the reference signal with a stability of ± 1 ppm from -30°C (Optional -40°C) to $+60^{\circ}\text{C}$.
- 2) External reference input. Install jumper JU1-A and JU2 on the Analog Board. This mode is used in applications requiring better than ± 1 ppm frequency stability. An external reference signal must be provided at synthesizer SMB connector J1.
- 3) Reference Frequency Select. Install jumper JU2 on the Digital Board to select a 10.0 MHz reference frequency. When not installed, the reference frequency is by default 9.6 MHz. JU2 must not be installed when using the internal 9.6 MHz TCXO reference. JU2 is used by the microcontroller to establish the correct reference frequency division ratio. (Located on the Digital Board; The Synthesizer module must be removed to change jumper JU2.)
- 4) AM Multichannel Synthesizer Select. Install jumper JU1 on the Digital Board to select and enable the AM Multichannel Synthesizer with Frequency Select Handle.

Caution: Care must be exercised when reinstalling the synthesizer module on the Transmitter Main board or the IF/Audio board. Pay careful attention to pin alignment before pressing the synthesizer module into its mating sockets.

This Page Intentionally Left Blank

4 ILLUSTRATIONS AND SCHEMATIC DIAGRAMS

4.1 OS(R/T)-3H 29 - 71.4 MHz Analog Board Diagrams

4.1.1 OS(R/T)-3H 29 - 71.4 MHz Analog Board Component Layout (Bottom)

5. PARTS LISTS

5.1 OS(R/T)-3H 29 - 71.4 MHz Analog Board Electrical Parts List

6. REVISION HISTORY

ISSUE	DATE	REVISION
-------	------	----------

- | | | |
|---|--------|--|
| 1 | May 97 | • Issue 1 |
| 2 | Mar 98 | • Changes to the AM Analog board (OST-3A128) to improve performance ECO #547.
C37 was XXX nF is now XXX nF and C40 was XXX pF is now not installed
C45 was XXX nF is now XXX nF and C49 was XXX nF is now XXX nF
R32 was XXX kΩ is now XXX kΩ and R36 was XXX Ω is now XXX Ω |
| 3 | Mar 00 | • Changes to the AM Analog board to improve performance at -40°C. ECO #565.
L4 was XXX μH is now XXX μH

• Changes to the FM Analog boards to improve manufacturing. ECO #572
C32 & C33 were XXX μF through hole tantalums are now XXX μF surface mount tantalums

• Changes to the OS-3A/H Digital board for compatibility with the new AM wideband Synthesizers. ECO #579.
Added C15 (XXX μF) and R41 (XXX kΩ).
JU1 was added and is installed for AM modules only.
PCB, DIGITAL, OS-3H/P SYNTH was version 2 now version 3.

• Added the new component layouts, schematic diagram and parts lists for the new AM wideband synthesizer. Wideband referring to only having to be tune once and working over the whole AM band (118-138 MHz). |
| 4 | May 00 | • Changes to the OS-3H 128-174 MHz Analog board. ECO #603.
R29 was XXX is now XXX, U10 was XXXXX is now XXXXX.

• Changes to the OSR-3H 128-174 MHz Analog board. ECO #609.
R22 was XXX R is now XXX R.

• Changes to the OS-3A 118-159.4 Analog board. ECO #601.
R42 & R53 were XXX kΩ are now XXX kΩ. |
| | Jul 00 | • Corrected the SELECT table on the OS(R/T)-3H 128-174 MHz Schematic diagram (section 4.3.3). |

ISSUE DATE REVISION

- 4 Aug 00 • Changes to the OS(R/T)-3(A/H) Digital board. ECO #599.
R30, R31 & R32 were XXX R are now XXX R.
- Changes to the OS-3H 406-470 MHz Analog board. ECO # 597.
R48 was XXX R is now XXX R, R49 was XXX R is now XXX R.
R52 was XXX R is now Not Installed.



MT-3 RADIO SYSTEMS

UHF SYNTHESIZED TRANSMITTER CHANNEL DESIGNATION TABLES

UT-3/400 406 - 470 MHz

Covers models:

UT-3/420-SNC2, UT-3/420-SWC2, UT-3/420-SNC8, UT-3/420-SWC8,
UT-3/460-SNC2, UT-3/460-SWC2, UT-3/460-SNC8, UT-3/460-SWC8,

Copyright © 1998 Daniels Electronics Ltd. All rights reserved. No part of this publication may be reproduced, stored in a retrieval system or transmitted in any form or by any means, electronic, mechanical, photocopying, recording or otherwise, without the prior written consent of Daniels Electronics Ltd.

DE™ is a registered trademark of Daniels Electronic Ltd. registered in the United States Patent and Trademark Office.

Issue:	1	Previous Issue:	N/A	
Issue Date:	September 1998	Previous Issue Date:	N/A	Daniels Electronics Ltd.
Printing Date:	September 1998			Victoria, BC.
Part No.:	IM23-UT3400CT			PRINTED IN CANADA

Reviewed By:

Quality Assurance:

LARRY FREEMAN

Name

Signature

Date

NOTE:

The user's authority to operate this equipment could be revoked through any changes or modifications not expressly approved by Daniels Electronics Ltd.

The design of this equipment is subject to change due to continuous development. This equipment may incorporate minor changes in detail from the information contained in this manual.

TABLE OF CONTENTS

	Page
1. UT-3/420 Channel Designation Table: 406-430MHz, 12.5kHz Increments	1-1
2. UT-3/460 Channel Designation Table: 450-470MHz, 12.5kHz Increments	2-1
3. REVISION HISTORY	3-1

This Page Intentionally Left Blank

1. UT-3/420 Channel Designation Table: 406-430MHz, 12.5kHz Increments

Chan. Num.	Freq. (MHz)	Chan. Num.	Freq. (MHz)	Chan. Num.	Freq. (MHz)	Chan. Num.	Freq. (MHz)	Chan. Num.	Freq. (MHz)	Chan. Num.	Freq. (MHz)	Chan. Num.	Freq. (MHz)
0000	406.00000	0075	406.93750	0150	407.87500	0225	408.81250	0300	409.75000	0375	410.68750	0450	411.62500
0001	.01250	0076	.95000	0151	.88750	0226	.82500	0301	.76250	0376	.70000	0451	.63750
0002	.02500	0077	.96250	0152	.90000	0227	.83750	0302	.77500	0377	.71250	0452	.65000
0003	.03750	0078	.97500	0153	.91250	0228	.85000	0303	.78750	0378	.72500	0453	.66250
0004	.05000	0079	.98750	0154	.92500	0229	.86250	0304	.80000	0379	.73750	0454	.67500
0005	.06250	0080	407.00000	0155	.93750	0230	.87500	0305	.81250	0380	410.75000	0455	.68750
0006	.07500	0081	.01250	0156	.95000	0231	.88750	0306	.82500	0381	.76250	0456	.70000
0007	.08750	0082	.02500	0157	.96250	0232	.90000	0307	.83750	0382	.77500	0457	.71250
0008	.10000	0083	.03750	0158	.97500	0233	.91250	0308	.85000	0383	.78750	0458	.72500
0009	.11250	0084	.05000	0159	.98750	0234	.92500	0309	.86250	0384	.80000	0459	.73750
00010	.12500	0085	.06250	0160	408.00000	0235	.93750	0310	.87500	0385	.81250	0460	411.75000
0011	.13750	0086	.07500	0161	.01250	0236	.95000	0311	.88750	0386	.82500	0461	.76250
0012	.15000	0087	.08750	0162	.02500	0237	.96250	0312	.90000	0387	.83750	0462	.77500
0013	.16250	0088	.10000	0163	.03750	0238	.97500	0313	.91250	0388	.85000	0463	.78750
0014	.17500	0089	.11250	0164	.05000	0239	.98750	0314	.92500	0389	.86250	0464	.80000
0015	.18750	0090	.12500	0165	.06250	0240	409.00000	0315	.93750	0390	.87500	0465	.81250
0016	.20000	0091	.13750	0166	.07500	0241	.01250	0316	.95000	0391	.88750	0466	.82500
0017	.21250	0092	.15000	0167	.08750	0242	.02500	0317	.96250	0392	.90000	0467	.83750
0018	.22500	0093	.16250	0168	.10000	0243	.03750	0318	.97500	0393	.91250	0468	.85000
0019	.23750	0094	.17500	0169	.11250	0244	.05000	0319	.98750	0394	.92500	0469	.86250
0020	406.25000	0095	.18750	0170	.12500	0245	.06250	0320	410.00000	0395	.93750	0470	.87500
0021	.26250	0096	.20000	0171	.13750	0246	.07500	0321	.01250	0396	.95000	0471	.88750
0022	.27500	0097	.21250	0172	.15000	0247	.08750	0322	.02500	0397	.96250	0472	.90000
0023	.28750	0098	.22500	0173	.16250	0248	.10000	0323	.03750	0398	.97500	0473	.91250
0024	.30000	0099	.23750	0174	.17500	0249	.11250	0324	.05000	0399	.98750	0474	.92500
0025	.31250	0100	407.25000	0175	.18750	0250	.12500	0325	.06250	0400	411.00000	0475	.93750
0026	.32500	0101	.26250	0176	.20000	0251	.13750	0326	.07500	0401	.01250	0476	.95000
0027	.33750	0102	.27500	0177	.21250	0252	.15000	0327	.08750	0402	.02500	0477	.96250
0028	.35000	0103	.28750	0178	.22500	0253	.16250	0328	.10000	0403	.03750	0478	.97500
0029	.36250	0104	.30000	0179	.23750	0254	.17500	0329	.11250	0404	.05000	0479	.98750
0030	.37500	0105	.31250	0180	408.25000	0255	.18750	0330	.12500	0405	.06250	0480	412.00000
0031	.38750	0106	.32500	0181	.26250	0256	.20000	0331	.13750	0406	.07500	0481	.01250
0032	.40000	0107	.33750	0182	.27500	0257	.21250	0332	.15000	0407	.08750	0482	.02500
0033	.41250	0108	.35000	0183	.28750	0258	.22500	0333	.16250	0408	.10000	0483	.03750
0034	.42500	0109	.36250	0184	.30000	0259	.23750	0334	.17500	0409	.11250	0484	.05000
0035	.43750	0110	.37500	0185	.31250	0260	409.25000	0335	.18750	0410	.12500	0485	.06250
0036	.45000	0111	.38750	0186	.32500	0261	.26250	0336	.20000	0411	.13750	0486	.07500
0037	.46250	0112	.40000	0187	.33750	0262	.27500	0337	.21250	0412	.15000	0487	.08750
0038	.47500	0113	.41250	0188	.35000	0263	.28750	0338	.22500	0413	.16250	0488	.10000
0039	.48750	0114	.42500	0189	.36250	0264	.30000	0339	.23750	0414	.17500	0489	.11250
0040	406.50000	0115	.43750	0190	.37500	0265	.31250	0340	410.25000	0415	.18750	0490	.12500
0041	.51250	0116	.45000	0191	.38750	0266	.32500	0341	.26250	0416	.20000	0491	.13750
0042	.52500	0117	.46250	0192	.40000	0267	.33750	0342	.27500	0417	.21250	0492	.15000
0043	.53750	0118	.47500	0193	.41250	0268	.35000	0343	.28750	0418	.22500	0493	.16250
0044	.55000	0119	.48750	0194	.42500	0269	.36250	0344	.30000	0419	.23750	0494	.17500
0045	.56250	0120	407.50000	0195	.43750	0270	.37500	0345	.31250	0420	411.25000	0495	.18750
0046	.57500	0121	.51250	0196	.45000	0271	.38750	0346	.32500	0421	.26250	0496	.20000
0047	.58750	0122	.52500	0197	.46250	0272	.40000	0347	.33750	0422	.27500	0497	.21250
0048	.60000	0123	.53750	0198	.47500	0273	.41250	0348	.35000	0423	.28750	0498	.22500
0049	.61250	0124	.55000	0199	.48750	0274	.42500	0349	.36250	0424	.30000	0499	.23750
0050	.62500	0125	.56250	0200	408.50000	0275	.43750	0350	.37500	0425	.31250	0500	412.25000
0051	.63750	0126	.57500	0201	.51250	0276	.45000	0351	.38750	0426	.32500	0501	.26250
0052	.65000	0127	.58750	0202	.52500	0277	.46250	0352	.40000	0427	.33750	0502	.27500
0053	.66250	0128	.60000	0203	.53750	0278	.47500	0353	.41250	0428	.35000	0503	.28750
0054	.67500	0129	.61250	0204	.55000	0279	.48750	0354	.42500	0429	.36250	0504	.30000
0055	.68750	0130	.62500	0205	.56250	0280	409.50000	0355	.43750	0430	.37500	0505	.31250
0056	.70000	0131	.63750	0206	.57500	0281	.51250	0356	.45000	0431	.38750	0506	.32500
0057	.71250	0132	.65000	0207	.58750	0282	.52500	0357	.46250	0432	.40000	0507	.33750
0058	.72500	0133	.66250	0208	.60000	0283	.53750	0358	.47500	0433	.41250	0508	.35000
0059	.73750	0134	.67500	0209	.61250	0284	.55000	0359	.48750	0434	.42500	0509	.36250
0060	406.75000	0135	.68750	0210	.62500	0285	.56250	0360	410.50000	0435	.43750	0510	.37500
0061	.76250	0136	.70000	0211	.63750	0286	.57500	0361	.51250	0436	.45000	0511	.38750
0062	.77500	0137	.71250	0212	.65000	0287	.58750	0362	.52500	0437	.46250	0512	.40000
0063	.78750	0138	.72500	0213	.66250	0288	.60000	0363	.53750	0438	.47500	0513	.41250
0064	.80000	0139	.73750	0214	.67500	0289	.61250	0364	.55000	0439	.48750	0514	.42500
0065	.81250	0140	407.75000	0215	.68750	0290	.62500	0365	.56250	0440	411.50000	0515	.43750
0066	.82500	0141	.76250	0216	.70000	0291	.63750	0366	.57500	0441	.51250	0516	.45000
0067	.83750	0142	.77500	0217	.71250	0292	.65000	0367	.58750	0442	.52500	0517	.46250
0068	.85000	0143	.78750	0218	.72500	0293	.66250	0368	.60000	0443	.53750	0518	.47500
0069	.86250	0144	.80000	0219	.73750	0294	.67500	0369	.61250	0444	.55000	0519	.48750
0070	.87500	0145	.81250	0220	408.75000	0295	.68750	0370	.62500	0445	.56250	0520	412.50000
0071	.88750	0146	.82500	0221	.76250	0296	.70000	0371	.63750	0446	.57500	0521	.51250
0072	.90000	0147	.83750	0222	.77500	0297	.71250	0372	.65000	0447	.58750	0522	.52500
0073	.91250	0148	.85000	0223	.78750	0298	.72500	0373	.66250	0448	.60000	0523	.53750
0074	.92500	0149	.86250	0224	.80000	0299	.73750	0374	.67500	0449	.61250	0524	.55000

UT-3/420 Channel Designation Table: 406 to 430 MHz, 12.5 kHz Increments (continued)

Chan. Num.	Freq. (MHz)	Chan. Num.	Freq. (MHz)	Chan. Num.	Freq. (MHz)	Chan. Num.	Freq. (MHz)	Chan. Num.	Freq. (MHz)	Chan. Num.	Freq. (MHz)	Chan. Num.	Freq. (MHz)
0525	412.56250	0600	413.50000	0675	414.43750	0750	415.37500	0825	416.31250	0900	417.25000	0975	418.18750
0526	.57500	0601	.51250	0676	.45000	0751	.38750	0826	.32500	0901	.26250	0976	.20000
0527	.58750	0602	.52500	0677	.46250	0752	.40000	0827	.33750	0902	.27500	0977	.21250
0528	.60000	0603	.53750	0678	.47500	0753	.41250	0828	.35000	0903	.28750	0978	.22500
0529	.61250	0604	.55000	0679	.48750	0754	.42500	0829	.36250	0904	.30000	0979	.23750
0530	.62500	0605	.56250	0680	414.50000	0755	.43750	0830	.37500	0905	.31250	0980	418.25000
0531	.63750	0606	.57500	0681	.51250	0756	.45000	0831	.38750	0906	.32500	0981	.26250
0532	.65000	0607	.58750	0682	.52500	0757	.46250	0832	.40000	0907	.33750	0982	.27500
0533	.66250	0608	.60000	0683	.53750	0758	.47500	0833	.41250	0908	.35000	0983	.28750
0534	.67500	0609	.61250	0684	.55000	0759	.48750	0834	.42500	0909	.36250	0984	.30000
0535	.68750	0610	.62500	0685	.56250	0760	415.50000	0835	.43750	0910	.37500	0985	.31250
0536	.70000	0611	.63750	0686	.57500	0761	.51250	0836	.45000	0911	.38750	0986	.32500
0537	.71250	0612	.65000	0687	.58750	0762	.52500	0837	.46250	0912	.40000	0987	.33750
0538	.72500	0613	.66250	0688	.60000	0763	.53750	0838	.47500	0913	.41250	0988	.35000
0539	.73750	0614	.67500	0689	.61250	0764	.55000	0839	.48750	0914	.42500	0989	.36250
0540	412.75000	0615	.68750	0690	.62500	0765	.56250	0840	416.50000	0915	.43750	0990	.37500
0541	.76250	0616	.70000	0691	.63750	0766	.57500	0841	.51250	0916	.45000	0991	.38750
0542	.77500	0617	.71250	0692	.65000	0767	.58750	0842	.52500	0917	.46250	0992	.40000
0543	.78750	0618	.72500	0693	.66250	0768	.60000	0843	.53750	0918	.47500	0993	.41250
0544	.80000	0619	.73750	0694	.67500	0769	.61250	0844	.55000	0919	.48750	0994	.42500
0545	.81250	0620	413.75000	0695	.68750	0770	.62500	0845	.56250	0920	417.50000	0995	.43750
0546	.82500	0621	.76250	0696	.70000	0771	.63750	0846	.57500	0921	.51250	0996	.45000
0547	.83750	0622	.77500	0697	.71250	0772	.65000	0847	.58750	0922	.52500	0997	.46250
0548	.85000	0623	.78750	0698	.72500	0773	.66250	0848	.60000	0923	.53750	0998	.47500
0549	.86250	0624	.80000	0699	.73750	0774	.67500	0849	.61250	0924	.55000	0999	.48750
0550	.87500	0625	.81250	0700	414.75000	0775	.68750	0850	.62500	0925	.56250	1000	418.50000
0551	.88750	0626	.82500	0701	.76250	0776	.70000	0851	.63750	0926	.57500	1001	.51250
0552	.90000	0627	.83750	0702	.77500	0777	.71250	0852	.65000	0927	.58750	1002	.52500
0553	.91250	0628	.85000	0703	.78750	0778	.72500	0853	.66250	0928	.60000	1003	.53750
0554	.92500	0629	.86250	0704	.80000	0779	.73750	0854	.67500	0929	.61250	1004	.55000
0555	.93750	0630	.87500	0705	.81250	0780	415.75000	0855	.68750	0930	.62500	1005	.56250
0556	.95000	0631	.88750	0706	.82500	0781	.76250	0856	.70000	0931	.63750	1006	.57500
0557	.96250	0632	.90000	0707	.83750	0782	.77500	0857	.71250	0932	.65000	1007	.58750
0558	.97500	0633	.91250	0708	.85000	0783	.78750	0858	.72500	0933	.66250	1008	.60000
0559	.98750	0634	.92500	0709	.86250	0784	.80000	0859	.73750	0934	.67500	1009	.61250
0560	413.00000	0635	.93750	0710	.87500	0785	.81250	0860	416.75000	0935	.68750	1010	.62500
0561	.01250	0636	.95000	0711	.88750	0786	.82500	0861	.76250	0936	.70000	1011	.63750
0562	.02500	0637	.96250	0712	.90000	0787	.83750	0862	.77500	0937	.71250	1012	.65000
0563	.03750	0638	.97500	0713	.91250	0788	.85000	0863	.78750	0938	.72500	1013	.66250
0564	.05000	0639	.98750	0714	.92500	0789	.86250	0864	.80000	0939	.73750	1014	.67500
0565	.06250	0640	414.00000	0715	.93750	0790	.87500	0865	.81250	0940	417.75000	1015	.68750
0566	.07500	0641	.01250	0716	.95000	0791	.88750	0866	.82500	0941	.76250	1016	.70000
0567	.08750	0642	.02500	0717	.96250	0792	.90000	0867	.83750	0942	.77500	1017	.71250
0568	.10000	0643	.03750	0718	.97500	0793	.91250	0868	.85000	0943	.78750	1018	.72500
0569	.11250	0644	.05000	0719	.98750	0794	.92500	0869	.86250	0944	.80000	1019	.73750
0570	.12500	0645	.06250	0720	415.00000	0795	.93750	0870	.87500	0945	.81250	1020	418.75000
0571	.13750	0646	.07500	0721	.01250	0796	.95000	0871	.88750	0946	.82500	1021	.76250
0572	.15000	0647	.08750	0722	.02500	0797	.96250	0872	.90000	0947	.83750	1022	.77500
0573	.16250	0648	.10000	0723	.03750	0798	.97500	0873	.91250	0948	.85000	1023	.78750
0574	.17500	0649	.11250	0724	.05000	0799	.98750	0874	.92500	0949	.86250	1024	.80000
0575	.18750	0650	.12500	0725	.06250	0800	416.00000	0875	.93750	0950	.87500	1025	.81250
0576	.20000	0651	.13750	0726	.07500	0801	.01250	0876	.95000	0951	.88750	1026	.82500
0577	.21250	0652	.15000	0727	.08750	0802	.02500	0877	.96250	0952	.90000	1027	.83750
0578	.22500	0653	.16250	0728	.10000	0803	.03750	0878	.97500	0953	.91250	1028	.85000
0579	.23750	0654	.17500	0729	.11250	0804	.05000	0879	.98750	0954	.92500	1029	.86250
0580	413.25000	0655	.18750	0730	.12500	0805	.06250	0880	417.00000	0955	.93750	1030	.87500
0581	.26250	0656	.20000	0731	.13750	0806	.07500	0881	.01250	0956	.95000	1031	.88750
0582	.27500	0657	.21250	0732	.15000	0807	.08750	0882	.02500	0957	.96250	1032	.90000
0583	.28750	0658	.22500	0733	.16250	0808	.10000	0883	.03750	0958	.97500	1033	.91250
0584	.30000	0659	.23750	0734	.17500	0809	.11250	0884	.05000	0959	.98750	1034	.92500
0585	.31250	0660	414.25000	0735	.18750	0810	.12500	0885	.06250	0960	418.00000	1035	.93750
0586	.32500	0661	.26250	0736	.20000	0811	.13750	0886	.07500	0961	.01250	1036	.95000
0587	.33750	0662	.27500	0737	.21250	0812	.15000	0887	.08750	0962	.02500	1037	.96250
0588	.35000	0663	.28750	0738	.22500	0813	.16250	0888	.10000	0963	.03750	1038	.97500
0589	.36250	0664	.30000	0739	.23750	0814	.17500	0889	.11250	0964	.05000	1039	.98750
0590	.37500	0665	.31250	0740	415.25000	0815	.18750	0890	.12500	0965	.06250	1040	419.00000
0591	.38750	0666	.32500	0741	.26250	0816	.20000	0891	.13750	0966	.07500	1041	.01250
0592	.40000	0667	.33750	0742	.27500	0817	.21250	0892	.15000	0967	.08750	1042	.02500
0593	.41250	0668	.35000	0743	.28750	0818	.22500	0893	.16250	0968	.10000	1043	.03750
0594	.42500	0669	.36250	0744	.30000	0819	.23750	0894	.17500	0969	.11250	1044	.05000
0595	.43750	0670	.37500	0745	.31250	0820	416.25000	0895	.18750	0970	.12500	1045	.06250
0596	.45000	0671	.38750	0746	.32500	0821	.26250	0896	.20000	0971	.13750	1046	.07500
0597	.46250	0672	.40000	0747	.33750	0822	.27500	0897	.21250	0972	.15000	1047	.08750
0598	.47500	0673	.41250	0748	.35000	0823	.28750	0898	.22500	0973	.16250	1048	.10000
0599	.48750	0674	.42500	0749	.36250	0824	.30000	0899	.23750	0974	.17500	1049	.11250

UT-3/420 Channel Designation Table: 406 to 430 MHz, 12.5 kHz Increments (continued)

Chan. Num.	Freq. (MHz)	Chan. Num.	Freq. (MHz)	Chan. Num.	Freq. (MHz)	Chan. Num.	Freq. (MHz)	Chan. Num.	Freq. (MHz)	Chan. Num.	Freq. (MHz)	Chan. Num.	Freq. (MHz)
1050	419.12500	1125	420.06250	1200	421.00000	1275	421.93750	1350	422.87500	1425	423.81250	1500	424.75000
1051	.13750	1126	.07500	1201	.01250	1276	.95000	1351	.88750	1426	.82500	1501	.76250
1052	.15000	1127	.08750	1202	.02500	1277	.96250	1352	.90000	1427	.83750	1502	.77500
1053	.16250	1128	.10000	1203	.03750	1278	.97500	1353	.91250	1428	.85000	1503	.78750
1054	.17500	1129	.11250	1204	.05000	1279	.98750	1354	.92500	1429	.86250	1504	.80000
1055	.18750	1130	.12500	1205	.06250	1280	422.00000	1355	.93750	1430	.87500	1505	.81250
1056	.20000	1131	.13750	1206	.07500	1281	.01250	1356	.95000	1431	.88750	1506	.82500
1057	.21250	1132	.15000	1207	.08750	1282	.02500	1357	.96250	1432	.90000	1507	.83750
1058	.22500	1133	.16250	1208	.10000	1283	.03750	1358	.97500	1433	.91250	1508	.85000
1059	.23750	1134	.17500	1209	.11250	1284	.05000	1359	.98750	1434	.92500	1509	.86250
1060	419.25000	1135	.18750	1210	.12500	1285	.06250	1360	423.00000	1435	.93750	1510	.87500
1061	.26250	1136	.20000	1211	.13750	1286	.07500	1361	.01250	1436	.95000	1511	.88750
1062	.27500	1137	.21250	1212	.15000	1287	.08750	1362	.02500	1437	.96250	1512	.90000
1063	.28750	1138	.22500	1213	.16250	1288	.10000	1363	.03750	1438	.97500	1513	.91250
1064	.30000	1139	.23750	1214	.17500	1289	.11250	1364	.05000	1439	.98750	1514	.92500
1065	.31250	1140	420.25000	1215	.18750	1290	.12500	1365	.06250	1440	424.00000	1515	.93750
1066	.32500	1141	.26250	1216	.20000	1291	.13750	1366	.07500	1441	.01250	1516	.95000
1067	.33750	1142	.27500	1217	.21250	1292	.15000	1367	.08750	1442	.02500	1517	.96250
1068	.35000	1143	.28750	1218	.22500	1293	.16250	1368	.10000	1443	.03750	1518	.97500
1069	.36250	1144	.30000	1219	.23750	1294	.17500	1369	.11250	1444	.05000	1519	.98750
1070	.37500	1145	.31250	1220	421.25000	1295	.18750	1370	.12500	1445	.06250	1520	425.00000
1071	.38750	1146	.32500	1221	.26250	1296	.20000	1371	.13750	1446	.07500	1521	.01250
1072	.40000	1147	.33750	1222	.27500	1297	.21250	1372	.15000	1447	.08750	1522	.02500
1073	.41250	1148	.35000	1223	.28750	1298	.22500	1373	.16250	1448	.10000	1523	.03750
1074	.42500	1149	.36250	1224	.30000	1299	.23750	1374	.17500	1449	.11250	1524	.05000
1075	.43750	1150	.37500	1225	.31250	1300	422.25000	1375	.18750	1450	.12500	1525	.06250
1076	.45000	1151	.38750	1226	.32500	1301	.26250	1376	.20000	1451	.13750	1526	.07500
1077	.46250	1152	.40000	1227	.33750	1302	.27500	1377	.21250	1452	.15000	1527	.08750
1078	.47500	1153	.41250	1228	.35000	1303	.28750	1378	.22500	1453	.16250	1528	.10000
1079	.48750	1154	.42500	1229	.36250	1304	.30000	1379	.23750	1454	.17500	1529	.11250
1080	419.50000	1155	.43750	1230	.37500	1305	.31250	1380	423.25000	1455	.18750	1530	.12500
1081	.51250	1156	.45000	1231	.38750	1306	.32500	1381	.26250	1456	.20000	1531	.13750
1082	.52500	1157	.46250	1232	.40000	1307	.33750	1382	.27500	1457	.21250	1532	.15000
1083	.53750	1158	.47500	1233	.41250	1308	.35000	1383	.28750	1458	.22500	1533	.16250
1084	.55000	1159	.48750	1234	.42500	1309	.36250	1384	.30000	1459	.23750	1534	.17500
1085	.56250	1160	420.50000	1235	.43750	1310	.37500	1385	.31250	1460	424.25000	1535	.18750
1086	.57500	1161	.51250	1236	.45000	1311	.38750	1386	.32500	1461	.26250	1536	.20000
1087	.58750	1162	.52500	1237	.46250	1312	.40000	1387	.33750	1462	.27500	1537	.21250
1088	.60000	1163	.53750	1238	.47500	1313	.41250	1388	.35000	1463	.28750	1538	.22500
1089	.61250	1164	.55000	1239	.48750	1314	.42500	1389	.36250	1464	.30000	1539	.23750
1090	.62500	1165	.56250	1240	421.50000	1315	.43750	1390	.37500	1465	.31250	1540	425.25000
1091	.63750	1166	.57500	1241	.51250	1316	.45000	1391	.38750	1466	.32500	1541	.26250
1092	.65000	1167	.58750	1242	.52500	1317	.46250	1392	.40000	1467	.33750	1542	.27500
1093	.66250	1168	.60000	1243	.53750	1318	.47500	1393	.41250	1468	.35000	1543	.28750
1094	.67500	1169	.61250	1244	.55000	1319	.48750	1394	.42500	1469	.36250	1544	.30000
1095	.68750	1170	.62500	1245	.56250	1320	422.50000	1395	.43750	1470	.37500	1545	.31250
1096	.70000	1171	.63750	1246	.57500	1321	.51250	1396	.45000	1471	.38750	1546	.32500
1097	.71250	1172	.65000	1247	.58750	1322	.52500	1397	.46250	1472	.40000	1547	.33750
1098	.72500	1173	.66250	1248	.60000	1323	.53750	1398	.47500	1473	.41250	1548	.35000
1099	.73750	1174	.67500	1249	.61250	1324	.55000	1399	.48750	1474	.42500	1549	.36250
1100	419.75000	1175	.68750	1250	.62500	1325	.56250	1400	423.50000	1475	.43750	1550	.37500
1101	.76250	1176	.70000	1251	.63750	1326	.57500	1401	.51250	1476	.45000	1551	.38750
1102	.77500	1177	.71250	1252	.65000	1327	.58750	1402	.52500	1477	.46250	1552	.40000
1103	.78750	1178	.72500	1253	.66250	1328	.60000	1403	.53750	1478	.47500	1553	.41250
1104	.80000	1179	.73750	1254	.67500	1329	.61250	1404	.55000	1479	.48750	1554	.42500
1105	.81250	1180	420.75000	1255	.68750	1330	.62500	1405	.56250	1480	424.50000	1555	.43750
1106	.82500	1181	.76250	1256	.70000	1331	.63750	1406	.57500	1481	.51250	1556	.45000
1107	.83750	1182	.77500	1257	.71250	1332	.65000	1407	.58750	1482	.52500	1557	.46250
1108	.85000	1183	.78750	1258	.72500	1333	.66250	1408	.60000	1483	.53750	1558	.47500
1109	.86250	1184	.80000	1259	.73750	1334	.67500	1409	.61250	1484	.55000	1559	.48750
1110	.87500	1185	.81250	1260	421.75000	1335	.68750	1410	.62500	1485	.56250	1560	425.50000
1111	.88750	1186	.82500	1261	.76250	1336	.70000	1411	.63750	1486	.57500	1561	.51250
1112	.90000	1187	.83750	1262	.77500	1337	.71250	1412	.65000	1487	.58750	1562	.52500
1113	.91250	1188	.85000	1263	.78750	1338	.72500	1413	.66250	1488	.60000	1563	.53750
1114	.92500	1189	.86250	1264	.80000	1339	.73750	1414	.67500	1489	.61250	1564	.55000
1115	.93750	1190	.87500	1265	.81250	1340	422.75000	1415	.68750	1490	.62500	1565	.56250
1116	.95000	1191	.88750	1266	.82500	1341	.76250	1416	.70000	1491	.63750	1566	.57500
1117	.96250	1192	.90000	1267	.83750	1342	.77500	1417	.71250	1492	.65000	1567	.58750
1118	.97500	1193	.91250	1268	.85000	1343	.78750	1418	.72500	1493	.66250	1568	.60000
1119	.98750	1194	.92500	1269	.86250	1344	.80000	1419	.73750	1494	.67500	1569	.61250
1120	420.00000	1195	.93750	1270	.87500	1345	.81250	1420	423.75000	1495	.68750	1570	.62500
1121	.01250	1196	.95000	1271	.88750	1346	.82500	1421	.76250	1496	.70000	1571	.63750
1122	.02500	1197	.96250	1272	.90000	1347	.83750	1422	.77500	1497	.71250	1572	.65000
1123	.03750	1198	.97500	1273	.91250	1348	.85000	1423	.78750	1498	.72500	1573	.66250
1124	.05000	1199	.98750	1274	.92500	1349	.86250	1424	.80000	1499	.73750	1574	.67500

UT-3/420 Channel Designation Table: 406 to 430 MHz, 12.5 kHz Increments (continued)

Chan. Num.	Freq. (MHz)	Chan. Num.	Freq. (MHz)	Chan. Num.	Freq. (MHz)	Chan. Num.	Freq. (MHz)	Chan. Num.	Freq. (MHz)	Chan. Num.	Freq. (MHz)	Chan. Num.	Freq. (MHz)
1575	425.68750	1650	426.62500	1725	427.56250	1800	428.50000	1875	429.43750				
1576	.70000	1651	.63750	1726	.57500	1801	.51250	1876	.45000				
1577	.71250	1652	.65000	1727	.58750	1802	.52500	1877	.46250				
1578	.72500	1653	.66250	1728	.60000	1803	.53750	1878	.47500				
1579	.73750	1654	.67500	1729	.61250	1804	.55000	1879	.48750				
1580	425.75000	1655	.68750	1730	.62500	1805	.56250	1880	429.50000				
1581	.76250	1656	.70000	1731	.63750	1806	.57500	1881	.51250				
1582	.77500	1657	.71250	1732	.65000	1807	.58750	1882	.52500				
1583	.78750	1658	.72500	1733	.66250	1808	.60000	1883	.53750				
1584	.80000	1659	.73750	1734	.67500	1809	.61250	1884	.55000				
1585	.81250	1660	426.75000	1735	.68750	1810	.62500	1885	.56250				
1586	.82500	1661	.76250	1736	.70000	1811	.63750	1886	.57500				
1587	.83750	1662	.77500	1737	.71250	1812	.65000	1887	.58750				
1588	.85000	1663	.78750	1738	.72500	1813	.66250	1888	.60000				
1589	.86250	1664	.80000	1739	.73750	1814	.67500	1889	.61250				
1590	.87500	1665	.81250	1740	427.75000	1815	.68750	1890	.62500				
1591	.88750	1666	.82500	1741	.76250	1816	.70000	1891	.63750				
1592	.90000	1667	.83750	1742	.77500	1817	.71250	1892	.65000				
1593	.91250	1668	.85000	1743	.78750	1818	.72500	1893	.66250				
1594	.92500	1669	.86250	1744	.80000	1819	.73750	1894	.67500				
1595	.93750	1670	.87500	1745	.81250	1820	428.75000	1895	.68750				
1596	.95000	1671	.88750	1746	.82500	1821	.76250	1896	.70000				
1597	.96250	1672	.90000	1747	.83750	1822	.77500	1897	.71250				
1598	.97500	1673	.91250	1748	.85000	1823	.78750	1898	.72500				
1599	.98750	1674	.92500	1749	.86250	1824	.80000	1899	.73750				
1600	426.00000	1675	.93750	1750	.87500	1825	.81250	1900	429.75000				
1601	.01250	1676	.95000	1751	.88750	1826	.82500	1901	.76250				
1602	.02500	1677	.96250	1752	.90000	1827	.83750	1902	.77500				
1603	.03750	1678	.97500	1753	.91250	1828	.85000	1903	.78750				
1604	.05000	1679	.98750	1754	.92500	1829	.86250	1904	.80000				
1605	.06250	1680	427.00000	1755	.93750	1830	.87500	1905	.81250				
1606	.07500	1681	.01250	1756	.95000	1831	.88750	1906	.82500				
1607	.08750	1682	.02500	1757	.96250	1832	.90000	1907	.83750				
1608	.10000	1683	.03750	1758	.97500	1833	.91250	1908	.85000				
1609	.11250	1684	.05000	1759	.98750	1834	.92500	1909	.86250				
1610	.12500	1685	.06250	1760	428.00000	1835	.93750	1910	.87500				
1611	.13750	1686	.07500	1761	.01250	1836	.95000	1911	.88750				
1612	.15000	1687	.08750	1762	.02500	1837	.96250	1912	.90000				
1613	.16250	1688	.10000	1763	.03750	1838	.97500	1913	.91250				
1614	.17500	1689	.11250	1764	.05000	1839	.98750	1914	.92500				
1615	.18750	1690	.12500	1765	.06250	1840	429.00000	1915	.93750				
1616	.20000	1691	.13750	1766	.07500	1841	.01250	1916	.95000				
1617	.21250	1692	.15000	1767	.08750	1842	.02500	1917	.96250				
1618	.22500	1693	.16250	1768	.10000	1843	.03750	1918	.97500				
1619	.23750	1694	.17500	1769	.11250	1844	.05000	1919	.98750				
1620	426.25000	1695	.18750	1770	.12500	1845	.06250	1920	430.00000				
1621	.26250	1696	.20000	1771	.13750	1846	.07500						
1622	.27500	1697	.21250	1772	.15000	1847	.08750						
1623	.28750	1698	.22500	1773	.16250	1848	.10000						
1624	.30000	1699	.23750	1774	.17500	1849	.11250						
1625	.31250	1700	427.25000	1775	.18750	1850	.12500						
1626	.32500	1701	.26250	1776	.20000	1851	.13750						
1627	.33750	1702	.27500	1777	.21250	1852	.15000						
1628	.35000	1703	.28750	1778	.22500	1853	.16250						
1629	.36250	1704	.30000	1779	.23750	1854	.17500						
1630	.37500	1705	.31250	1780	428.25000	1855	.18750						
1631	.38750	1706	.32500	1781	.26250	1856	.20000						
1632	.40000	1707	.33750	1782	.27500	1857	.21250						
1633	.41250	1708	.35000	1783	.28750	1858	.22500						
1634	.42500	1709	.36250	1784	.30000	1859	.23750						
1635	.43750	1710	.37500	1785	.31250	1860	429.25000						
1636	.45000	1711	.38750	1786	.32500	1861	.26250						
1637	.46250	1712	.40000	1787	.33750	1862	.27500						
1638	.47500	1713	.41250	1788	.35000	1863	.28750						
1639	.48750	1714	.42500	1789	.36250	1864	.30000						
1640	426.50000	1715	.43750	1790	.37500	1865	.31250						
1641	.51250	1716	.45000	1791	.38750	1866	.32500						
1642	.52500	1717	.46250	1792	.40000	1867	.33750						
1643	.53750	1718	.47500	1793	.41250	1868	.35000						
1644	.55000	1719	.48750	1794	.42500	1869	.36250						
1645	.56250	1720	427.50000	1795	.43750	1870	.37500						
1646	.57500	1721	.51250	1796	.45000	1871	.38750						
1647	.58750	1722	.52500	1797	.46250	1872	.40000						
1648	.60000	1723	.53750	1798	.47500	1873	.41250						
1649	.61250	1724	.55000	1799	.48750	1874	.42500						

2 UT-3/460 Channel Designation Table: 450-470MHz, 12.5kHz Increments

Chan. Num.	Freq. (MHz)	Chan. Num.	Freq. (MHz)	Chan. Num.	Freq. (MHz)	Chan. Num.	Freq. (MHz)	Chan. Num.	Freq. (MHz)	Chan. Num.	Freq. (MHz)	Chan. Num.	Freq. (MHz)
3520	450.00000	3595	450.93750	3670	451.87500	3745	452.81250	3820	453.75000	3895	454.68750	3970	455.62500
3521	.01250	3596	.95000	3671	.88750	3746	.82500	3821	.76250	3896	.70000	3971	.63750
3522	.02500	3597	.96250	3672	.90000	3747	.83750	3822	.77500	3897	.71250	3972	.65000
3523	.03750	3598	.97500	3673	.91250	3748	.85000	3823	.78750	3898	.72500	3973	.66250
3524	.05000	3599	.98750	3674	.92500	3749	.86250	3824	.80000	3899	.73750	3974	.67500
3525	.06250	3600	451.00000	3675	.93750	3750	.87500	3825	.81250	3900	454.75000	3975	.68750
3526	.07500	3601	.01250	3676	.95000	3751	.88750	3826	.82500	3901	.76250	3976	.70000
3527	.08750	3602	.02500	3677	.96250	3752	.90000	3827	.83750	3902	.77500	3977	.71250
3528	.10000	3603	.03750	3678	.97500	3753	.91250	3828	.85000	3903	.78750	3978	.72500
3529	.11250	3604	.05000	3679	.98750	3754	.92500	3829	.86250	3904	.80000	3979	.73750
3530	.12500	3605	.06250	3680	452.00000	3755	.93750	3830	.87500	3905	.81250	3980	455.75000
3531	.13750	3606	.07500	3681	.01250	3756	.95000	3831	.88750	3906	.82500	3981	.76250
3532	.15000	3607	.08750	3682	.02500	3757	.96250	3832	.90000	3907	.83750	3982	.77500
3533	.16250	3608	.10000	3683	.03750	3758	.97500	3833	.91250	3908	.85000	3983	.78750
3534	.17500	3609	.11250	3684	.05000	3759	.98750	3834	.92500	3909	.86250	3984	.80000
3535	.18750	3610	.12500	3685	.06250	3760	453.00000	3835	.93750	3910	.87500	3985	.81250
3536	.20000	3611	.13750	3686	.07500	3761	.01250	3836	.95000	3911	.88750	3986	.82500
3537	.21250	3612	.15000	3687	.08750	3762	.02500	3837	.96250	3912	.90000	3987	.83750
3538	.22500	3613	.16250	3688	.10000	3763	.03750	3838	.97500	3913	.91250	3988	.85000
3539	.23750	3614	.17500	3689	.11250	3764	.05000	3839	.98750	3914	.92500	3989	.86250
3540	450.25000	3615	.18750	3690	.12500	3765	.06250	3840	454.00000	3915	.93750	3990	.87500
3541	.26250	3616	.20000	3691	.13750	3766	.07500	3841	.01250	3916	.95000	3991	.88750
3542	.27500	3617	.21250	3692	.15000	3767	.08750	3842	.02500	3917	.96250	3992	.90000
3543	.28750	3618	.22500	3693	.16250	3768	.10000	3843	.03750	3918	.97500	3993	.91250
3544	.30000	3619	.23750	3694	.17500	3769	.11250	3844	.05000	3919	.98750	3994	.92500
3545	.31250	3620	451.25000	3695	.18750	3770	.12500	3845	.06250	3920	455.00000	3995	.93750
3546	.32500	3621	.26250	3696	.20000	3771	.13750	3846	.07500	3921	.01250	3996	.95000
3547	.33750	3622	.27500	3697	.21250	3772	.15000	3847	.08750	3922	.02500	3997	.96250
3548	.35000	3623	.28750	3698	.22500	3773	.16250	3848	.10000	3923	.03750	3998	.97500
3549	.36250	3624	.30000	3699	.23750	3774	.17500	3849	.11250	3924	.05000	3999	.98750
3550	.37500	3625	.31250	3700	452.25000	3775	.18750	3850	.12500	3925	.06250	4000	456.00000
3551	.38750	3626	.32500	3701	.26250	3776	.20000	3851	.13750	3926	.07500	4001	.01250
3552	.40000	3627	.33750	3702	.27500	3777	.21250	3852	.15000	3927	.08750	4002	.02500
3553	.41250	3628	.35000	3703	.28750	3778	.22500	3853	.16250	3928	.10000	4003	.03750
3554	.42500	3629	.36250	3704	.30000	3779	.23750	3854	.17500	3929	.11250	4004	.05000
3555	.43750	3630	.37500	3705	.31250	3780	453.25000	3855	.18750	3930	.12500	4005	.06250
3556	.45000	3631	.38750	3706	.32500	3781	.26250	3856	.20000	3931	.13750	4006	.07500
3557	.46250	3632	.40000	3707	.33750	3782	.27500	3857	.21250	3932	.15000	4007	.08750
3558	.47500	3633	.41250	3708	.35000	3783	.28750	3858	.22500	3933	.16250	4008	.10000
3559	.48750	3634	.42500	3709	.36250	3784	.30000	3859	.23750	3934	.17500	4009	.11250
3560	450.50000	3635	.43750	3710	.37500	3785	.31250	3860	454.25000	3935	.18750	4010	.12500
3561	.51250	3636	.45000	3711	.38750	3786	.32500	3861	.26250	3936	.20000	4011	.13750
3562	.52500	3637	.46250	3712	.40000	3787	.33750	3862	.27500	3937	.21250	4012	.15000
3563	.53750	3638	.47500	3713	.41250	3788	.35000	3863	.28750	3938	.22500	4013	.16250
3564	.55000	3639	.48750	3714	.42500	3789	.36250	3864	.30000	3939	.23750	4014	.17500
3565	.56250	3640	451.50000	3715	.43750	3790	.37500	3865	.31250	3940	455.25000	4015	.18750
3566	.57500	3641	.51250	3716	.45000	3791	.38750	3866	.32500	3941	.26250	4016	.20000
3567	.58750	3642	.52500	3717	.46250	3792	.40000	3867	.33750	3942	.27500	4017	.21250
3568	.60000	3643	.53750	3718	.47500	3793	.41250	3868	.35000	3943	.28750	4018	.22500
3569	.61250	3644	.55000	3719	.48750	3794	.42500	3869	.36250	3944	.30000	4019	.23750
3570	.62500	3645	.56250	3720	452.50000	3795	.43750	3870	.37500	3945	.31250	4020	456.25000
3571	.63750	3646	.57500	3721	.51250	3796	.45000	3871	.38750	3946	.32500	4021	.26250
3572	.65000	3647	.58750	3722	.52500	3797	.46250	3872	.40000	3947	.33750	4022	.27500
3573	.66250	3648	.60000	3723	.53750	3798	.47500	3873	.41250	3948	.35000	4023	.28750
3574	.67500	3649	.61250	3724	.55000	3799	.48750	3874	.42500	3949	.36250	4024	.30000
3575	.68750	3650	.62500	3725	.56250	3800	453.50000	3875	.43750	3950	.37500	4025	.31250
3576	.70000	3651	.63750	3726	.57500	3801	.51250	3876	.45000	3951	.38750	4026	.32500
3577	.71250	3652	.65000	3727	.58750	3802	.52500	3877	.46250	3952	.40000	4027	.33750
3578	.72500	3653	.66250	3728	.60000	3803	.53750	3878	.47500	3953	.41250	4028	.35000
3579	.73750	3654	.67500	3729	.61250	3804	.55000	3879	.48750	3954	.42500	4029	.36250
3580	450.75000	3655	.68750	3730	.62500	3805	.56250	3880	454.50000	3955	.43750	4030	.37500
3581	.76250	3656	.70000	3731	.63750	3806	.57500	3881	.51250	3956	.45000	4031	.38750
3582	.77500	3657	.71250	3732	.65000	3807	.58750	3882	.52500	3957	.46250	4032	.40000
3583	.78750	3658	.72500	3733	.66250	3808	.60000	3883	.53750	3958	.47500	4033	.41250
3584	.80000	3659	.73750	3734	.67500	3809	.61250	3884	.55000	3959	.48750	4034	.42500
3585	.81250	3660	451.75000	3735	.68750	3810	.62500	3885	.56250	3960	455.50000	4035	.43750
3586	.82500	3661	.76250	3736	.70000	3811	.63750	3886	.57500	3961	.51250	4036	.45000
3587	.83750	3662	.77500	3737	.71250	3812	.65000	3887	.58750	3962	.52500	4037	.46250
3588	.85000	3663	.78750	3738	.72500	3813	.66250	3888	.60000	3963	.53750	4038	.47500
3589	.86250	3664	.80000	3739	.73750	3814	.67500	3889	.61250	3964	.55000	4039	.48750
3590	.87500	3665	.81250	3740	452.75000	3815	.68750	3890	.62500	3965	.56250	4040	456.50000
3591	.88750	3666	.82500	3741	.76250	3816	.70000	3891	.63750	3966	.57500	4041	.51250
3592	.90000	3667	.83750	3742	.77500	3817	.71250	3892	.65000	3967	.58750	4042	.52500
3593	.91250	3668	.85000	3743	.78750	3818	.72500	3893	.66250	3968	.60000	4043	.53750
3594	.92500	3669	.86250	3744	.80000	3819	.73750	3894	.67500	3969	.61250	4044	.55000

UT-3/460 Channel Designation Table: 450 to 470 MHz, 12.5 kHz Increments (continued)

Chan. Num.	Freq. (MHz)	Chan. Num.	Freq. (MHz)	Chan. Num.	Freq. (MHz)	Chan. Num.	Freq. (MHz)	Chan. Num.	Freq. (MHz)	Chan. Num.	Freq. (MHz)	Chan. Num.	Freq. (MHz)
4045	456.56250	4120	457.50000	4195	458.43750	4270	459.37500	4345	460.31250	4420	461.25000	4495	462.18750
4046	.57500	4121	.51250	4196	.45000	4271	.38750	4346	.32500	4421	.26250	4496	.20000
4047	.58750	4122	.52500	4197	.46250	4272	.40000	4347	.33750	4422	.27500	4497	.21250
4048	.60000	4123	.53750	4198	.47500	4273	.41250	4348	.35000	4423	.28750	4498	.22500
4049	.61250	4124	.55000	4199	.48750	4274	.42500	4349	.36250	4424	.30000	4499	.23750
4050	.62500	4125	.56250	4200	458.50000	4275	.43750	4350	.37500	4425	.31250	4500	462.25000
4051	.63750	4126	.57500	4201	.51250	4276	.45000	4351	.38750	4426	.32500	4501	.26250
4052	.65000	4127	.58750	4202	.52500	4277	.46250	4352	.40000	4427	.33750	4502	.27500
4053	.66250	4128	.60000	4203	.53750	4278	.47500	4353	.41250	4428	.35000	4503	.28750
4054	.67500	4129	.61250	4204	.55000	4279	.48750	4354	.42500	4429	.36250	4504	.30000
4055	.68750	4130	.62500	4205	.56250	4280	459.50000	4355	.43750	4430	.37500	4505	.31250
4056	.70000	4131	.63750	4206	.57500	4281	.51250	4356	.45000	4431	.38750	4506	.32500
4057	.71250	4132	.65000	4207	.58750	4282	.52500	4357	.46250	4432	.40000	4507	.33750
4058	.72500	4133	.66250	4208	.60000	4283	.53750	4358	.47500	4433	.41250	4508	.35000
4059	.73750	4134	.67500	4209	.61250	4284	.55000	4359	.48750	4434	.42500	4509	.36250
4060	456.75000	4135	.68750	4210	.62500	4285	.56250	4360	460.50000	4435	.43750	4510	.37500
4061	.76250	4136	.70000	4211	.63750	4286	.57500	4361	.51250	4436	.45000	4511	.38750
4062	.77500	4137	.71250	4212	.65000	4287	.58750	4362	.52500	4437	.46250	4512	.40000
4063	.78750	4138	.72500	4213	.66250	4288	.60000	4363	.53750	4438	.47500	4513	.41250
4064	.80000	4139	.73750	4214	.67500	4289	.61250	4364	.55000	4439	.48750	4514	.42500
4065	.81250	4140	457.75000	4215	.68750	4290	.62500	4365	.56250	4440	461.50000	4515	.43750
4066	.82500	4141	.76250	4216	.70000	4291	.63750	4366	.57500	4441	.51250	4516	.45000
4067	.83750	4142	.77500	4217	.71250	4292	.65000	4367	.58750	4442	.52500	4517	.46250
4068	.85000	4143	.78750	4218	.72500	4293	.66250	4368	.60000	4443	.53750	4518	.47500
4069	.86250	4144	.80000	4219	.73750	4294	.67500	4369	.61250	4444	.55000	4519	.48750
4070	.87500	4145	.81250	4220	458.75000	4295	.68750	4370	.62500	4445	.56250	4520	462.50000
4071	.88750	4146	.82500	4221	.76250	4296	.70000	4371	.63750	4446	.57500	4521	.51250
4072	.90000	4147	.83750	4222	.77500	4297	.71250	4372	.65000	4447	.58750	4522	.52500
4073	.91250	4148	.85000	4223	.78750	4298	.72500	4373	.66250	4448	.60000	4523	.53750
4074	.92500	4149	.86250	4224	.80000	4299	.73750	4374	.67500	4449	.61250	4524	.55000
4075	.93750	4150	.87500	4225	.81250	4300	459.75000	4375	.68750	4450	.62500	4525	.56250
4076	.95000	4151	.88750	4226	.82500	4301	.76250	4376	.70000	4451	.63750	4526	.57500
4077	.96250	4152	.90000	4227	.83750	4302	.77500	4377	.71250	4452	.65000	4527	.58750
4078	.97500	4153	.91250	4228	.85000	4303	.78750	4378	.72500	4453	.66250	4528	.60000
4079	.98750	4154	.92500	4229	.86250	4304	.80000	4379	.73750	4454	.67500	4529	.61250
4080	457.00000	4155	.93750	4230	.87500	4305	.81250	4380	460.75000	4455	.68750	4530	.62500
4081	.01250	4156	.95000	4231	.88750	4306	.82500	4381	.76250	4456	.70000	4531	.63750
4082	.02500	4157	.96250	4232	.90000	4307	.83750	4382	.77500	4457	.71250	4532	.65000
4083	.03750	4158	.97500	4233	.91250	4308	.85000	4383	.78750	4458	.72500	4533	.66250
4084	.05000	4159	.98750	4234	.92500	4309	.86250	4384	.80000	4459	.73750	4534	.67500
4085	.06250	4160	458.00000	4235	.93750	4310	.87500	4385	.81250	4460	461.75000	4535	.68750
4086	.07500	4161	.01250	4236	.95000	4311	.88750	4386	.82500	4461	.76250	4536	.70000
4087	.08750	4162	.02500	4237	.96250	4312	.90000	4387	.83750	4462	.77500	4537	.71250
4088	.10000	4163	.03750	4238	.97500	4313	.91250	4388	.85000	4463	.78750	4538	.72500
4089	.11250	4164	.05000	4239	.98750	4314	.92500	4389	.86250	4464	.80000	4539	.73750
4090	.12500	4165	.06250	4240	459.00000	4315	.93750	4390	.87500	4465	.81250	4540	462.75000
4091	.13750	4166	.07500	4241	.01250	4316	.95000	4391	.88750	4466	.82500	4541	.76250
4092	.15000	4167	.08750	4242	.02500	4317	.96250	4392	.90000	4467	.83750	4542	.77500
4093	.16250	4168	.10000	4243	.03750	4318	.97500	4393	.91250	4468	.85000	4543	.78750
4094	.17500	4169	.11250	4244	.05000	4319	.98750	4394	.92500	4469	.86250	4544	.80000
4095	.18750	4170	.12500	4245	.06250	4320	460.00000	4395	.93750	4470	.87500	4545	.81250
4096	.20000	4171	.13750	4246	.07500	4321	.01250	4396	.95000	4471	.88750	4546	.82500
4097	.21250	4172	.15000	4247	.08750	4322	.02500	4397	.96250	4472	.90000	4547	.83750
4098	.22500	4173	.16250	4248	.10000	4323	.03750	4398	.97500	4473	.91250	4548	.85000
4099	.23750	4174	.17500	4249	.11250	4324	.05000	4399	.98750	4474	.92500	4549	.86250
4100	457.25000	4175	.18750	4250	.12500	4325	.06250	4400	461.00000	4475	.93750	4550	.87500
4101	.26250	4176	.20000	4251	.13750	4326	.07500	4401	.01250	4476	.95000	4551	.88750
4102	.27500	4177	.21250	4252	.15000	4327	.08750	4402	.02500	4477	.96250	4552	.90000
4103	.28750	4178	.22500	4253	.16250	4328	.10000	4403	.03750	4478	.97500	4553	.91250
4104	.30000	4179	.23750	4254	.17500	4329	.11250	4404	.05000	4479	.98750	4554	.92500
4105	.31250	4180	458.25000	4255	.18750	4330	.12500	4405	.06250	4480	462.00000	4555	.93750
4106	.32500	4181	.26250	4256	.20000	4331	.13750	4406	.07500	4481	.01250	4556	.95000
4107	.33750	4182	.27500	4257	.21250	4332	.15000	4407	.08750	4482	.02500	4557	.96250
4108	.35000	4183	.28750	4258	.22500	4333	.16250	4408	.10000	4483	.03750	4558	.97500
4109	.36250	4184	.30000	4259	.23750	4334	.17500	4409	.11250	4484	.05000	4559	.98750
4110	.37500	4185	.31250	4260	459.25000	4335	.18750	4410	.12500	4485	.06250	4560	463.00000
4111	.38750	4186	.32500	4261	.26250	4336	.20000	4411	.13750	4486	.07500	4561	.01250
4112	.40000	4187	.33750	4262	.27500	4337	.21250	4412	.15000	4487	.08750	4562	.02500
4113	.41250	4188	.35000	4263	.28750	4338	.22500	4413	.16250	4488	.10000	4563	.03750
4114	.42500	4189	.36250	4264	.30000	4339	.23750	4414	.17500	4489	.11250	4564	.05000
4115	.43750	4190	.37500	4265	.31250	4340	460.25000	4415	.18750	4490	.12500	4565	.06250
4116	.45000	4191	.38750	4266	.32500	4341	.26250	4416	.20000	4491	.13750	4566	.07500
4117	.46250	4192	.40000	4267	.33750	4342	.27500	4417	.21250	4492	.15000	4567	.08750
4118	.47500	4193	.41250	4268	.35000	4343	.28750	4418	.22500	4493	.16250	4568	.10000
4119	.48750	4194	.42500	4269	.36250	4344	.30000	4419	.23750	4494	.17500	4569	.11250

UT-3/460 Channel Designation Table: 450 to 470 MHz, 12.5 kHz Increments (continued)

Chan. Num.	Freq. (MHz)	Chan. Num.	Freq. (MHz)	Chan. Num.	Freq. (MHz)	Chan. Num.	Freq. (MHz)	Chan. Num.	Freq. (MHz)	Chan. Num.	Freq. (MHz)	Chan. Num.	Freq. (MHz)
4570	463.12500	4645	464.06250	4720	465.00000	4795	465.93750	4870	466.87500	4945	467.81250	5020	468.75000
4571	.13750	4646	.07500	4721	.01250	4796	.95000	4871	.88750	4946	.82500	5021	.76250
4572	.15000	4647	.08750	4722	.02500	4797	.96250	4872	.90000	4947	.83750	5022	.77500
4573	.16250	4648	.10000	4723	.03750	4798	.97500	4873	.91250	4948	.85000	5023	.78750
4574	.17500	4649	.11250	4724	.05000	4799	.98750	4874	.92500	4949	.86250	5024	.80000
4575	.18750	4650	.12500	4725	.06250	4800	466.00000	4875	.93750	4950	.87500	5025	.81250
4576	.20000	4651	.13750	4726	.07500	4801	.01250	4876	.95000	4951	.88750	5026	.82500
4577	.21250	4652	.15000	4727	.08750	4802	.02500	4877	.96250	4952	.90000	5027	.83750
4578	.22500	4653	.16250	4728	.10000	4803	.03750	4878	.97500	4953	.91250	5028	.85000
4579	.23750	4654	.17500	4729	.11250	4804	.05000	4879	.98750	4954	.92500	5029	.86250
4580	463.25000	4655	.18750	4730	.12500	4805	.06250	4880	467.00000	4955	.93750	5030	.87500
4581	.26250	4656	.20000	4731	.13750	4806	.07500	4881	.01250	4956	.95000	5031	.88750
4582	.27500	4657	.21250	4732	.15000	4807	.08750	4882	.02500	4957	.96250	5032	.90000
4583	.28750	4658	.22500	4733	.16250	4808	.10000	4883	.03750	4958	.97500	5033	.91250
4584	.30000	4659	.23750	4734	.17500	4809	.11250	4884	.05000	4959	.98750	5034	.92500
4585	.31250	4660	464.25000	4735	.18750	4810	.12500	4885	.06250	4960	468.00000	5035	.93750
4586	.32500	4661	.26250	4736	.20000	4811	.13750	4886	.07500	4961	.01250	5036	.95000
4587	.33750	4662	.27500	4737	.21250	4812	.15000	4887	.08750	4962	.02500	5037	.96250
4588	.35000	4663	.28750	4738	.22500	4813	.16250	4888	.10000	4963	.03750	5038	.97500
4589	.36250	4664	.30000	4739	.23750	4814	.17500	4889	.11250	4964	.05000	5039	.98750
4590	.37500	4665	.31250	4740	465.25000	4815	.18750	4890	.12500	4965	.06250	5040	469.00000
4591	.38750	4666	.32500	4741	.26250	4816	.20000	4891	.13750	4966	.07500	5041	.01250
4592	.40000	4667	.33750	4742	.27500	4817	.21250	4892	.15000	4967	.08750	5042	.02500
4593	.41250	4668	.35000	4743	.28750	4818	.22500	4893	.16250	4968	.10000	5043	.03750
4594	.42500	4669	.36250	4744	.30000	4819	.23750	4894	.17500	4969	.11250	5044	.05000
4595	.43750	4670	.37500	4745	.31250	4820	466.25000	4895	.18750	4970	.12500	5045	.06250
4596	.45000	4671	.38750	4746	.32500	4821	.26250	4896	.20000	4971	.13750	5046	.07500
4597	.46250	4672	.40000	4747	.33750	4822	.27500	4897	.21250	4972	.15000	5047	.08750
4598	.47500	4673	.41250	4748	.35000	4823	.28750	4898	.22500	4973	.16250	5048	.10000
4599	.48750	4674	.42500	4749	.36250	4824	.30000	4899	.23750	4974	.17500	5049	.11250
4600	463.50000	4675	.43750	4750	.37500	4825	.31250	4900	467.25000	4975	.18750	5050	.12500
4601	.51250	4676	.45000	4751	.38750	4826	.32500	4901	.26250	4976	.20000	5051	.13750
4602	.52500	4677	.46250	4752	.40000	4827	.33750	4902	.27500	4977	.21250	5052	.15000
4603	.53750	4678	.47500	4753	.41250	4828	.35000	4903	.28750	4978	.22500	5053	.16250
4604	.55000	4679	.48750	4754	.42500	4829	.36250	4904	.30000	4979	.23750	5054	.17500
4605	.56250	4680	464.50000	4755	.43750	4830	.37500	4905	.31250	4980	468.25000	5055	.18750
4606	.57500	4681	.51250	4756	.45000	4831	.38750	4906	.32500	4981	.26250	5056	.20000
4607	.58750	4682	.52500	4757	.46250	4832	.40000	4907	.33750	4982	.27500	5057	.21250
4608	.60000	4683	.53750	4758	.47500	4833	.41250	4908	.35000	4983	.28750	5058	.22500
4609	.61250	4684	.55000	4759	.48750	4834	.42500	4909	.36250	4984	.30000	5059	.23750
4610	.62500	4685	.56250	4760	465.50000	4835	.43750	4910	.37500	4985	.31250	5060	469.25000
4611	.63750	4686	.57500	4761	.51250	4836	.45000	4911	.38750	4986	.32500	5061	.26250
4612	.65000	4687	.58750	4762	.52500	4837	.46250	4912	.40000	4987	.33750	5062	.27500
4613	.66250	4688	.60000	4763	.53750	4838	.47500	4913	.41250	4988	.35000	5063	.28750
4614	.67500	4689	.61250	4764	.55000	4839	.48750	4914	.42500	4989	.36250	5064	.30000
4615	.68750	4690	.62500	4765	.56250	4840	466.50000	4915	.43750	4990	.37500	5065	.31250
4616	.70000	4691	.63750	4766	.57500	4841	.51250	4916	.45000	4991	.38750	5066	.32500
4617	.71250	4692	.65000	4767	.58750	4842	.52500	4917	.46250	4992	.40000	5067	.33750
4618	.72500	4693	.66250	4768	.60000	4843	.53750	4918	.47500	4993	.41250	5068	.35000
4619	.73750	4694	.67500	4769	.61250	4844	.55000	4919	.48750	4994	.42500	5069	.36250
4620	463.75000	4695	.68750	4770	.62500	4845	.56250	4920	467.50000	4995	.43750	5070	.37500
4621	.76250	4696	.70000	4771	.63750	4846	.57500	4921	.51250	4996	.45000	5071	.38750
4622	.77500	4697	.71250	4772	.65000	4847	.58750	4922	.52500	4997	.46250	5072	.40000
4623	.78750	4698	.72500	4773	.66250	4848	.60000	4923	.53750	4998	.47500	5073	.41250
4624	.80000	4699	.73750	4774	.67500	4849	.61250	4924	.55000	4999	.48750	5074	.42500
4625	.81250	4700	464.75000	4775	.68750	4850	.62500	4925	.56250	5000	468.50000	5075	.43750
4626	.82500	4701	.76250	4776	.70000	4851	.63750	4926	.57500	5001	.51250	5076	.45000
4627	.83750	4702	.77500	4777	.71250	4852	.65000	4927	.58750	5002	.52500	5077	.46250
4628	.85000	4703	.78750	4778	.72500	4853	.66250	4928	.60000	5003	.53750	5078	.47500
4629	.86250	4704	.80000	4779	.73750	4854	.67500	4929	.61250	5004	.55000	5079	.48750
4630	.87500	4705	.81250	4780	465.75000	4855	.68750	4930	.62500	5005	.56250	5080	469.50000
4631	.88750	4706	.82500	4781	.76250	4856	.70000	4931	.63750	5006	.57500	5081	.51250
4632	.90000	4707	.83750	4782	.77500	4857	.71250	4932	.65000	5007	.58750	5082	.52500
4633	.91250	4708	.85000	4783	.78750	4858	.72500	4933	.66250	5008	.60000	5083	.53750
4634	.92500	4709	.86250	4784	.80000	4859	.73750	4934	.67500	5009	.61250	5084	.55000
4635	.93750	4710	.87500	4785	.81250	4860	466.75000	4935	.68750	5010	.62500	5085	.56250
4636	.95000	4711	.88750	4786	.82500	4861	.76250	4936	.70000	5011	.63750	5086	.57500
4637	.96250	4712	.90000	4787	.83750	4862	.77500	4937	.71250	5012	.65000	5087	.58750
4638	.97500	4713	.91250	4788	.85000	4863	.78750	4938	.72500	5013	.66250	5088	.60000
4639	.98750	4714	.92500	4789	.86250	4864	.80000	4939	.73750	5014	.67500	5089	.61250
4640	464.00000	4715	.93750	4790	.87500	4865	.81250	4940	467.75000	5015	.68750	5090	.62500
4641	.01250	4716	.95000	4791	.88750	4866	.82500	4941	.76250	5016	.70000	5091	.63750
4642	.02500	4717	.96250	4792	.90000	4867	.83750	4942	.77500	5017	.71250	5092	.65000
4643	.03750	4718	.97500	4793	.91250	4868	.85000	4943	.78750	5018	.72500	5093	.66250
4644	.05000	4719	.98750	4794	.92500	4869	.86250	4944	.80000	5019	.73750	5094	.67500

UT-3/460 Channel Designation Table: 450 to 470 MHz, 12.5 kHz Increments (continued)

Chan. Num.	Freq. (MHz)	Chan. Num.	Freq. (MHz)	Chan. Num.	Freq. (MHz)	Chan. Num.	Freq. (MHz)	Chan. Num.	Freq. (MHz)	Chan. Num.	Freq. (MHz)	Chan. Num.	Freq. (MHz)
5095	469.68750												
5096	.70000												
5097	.71250												
5098	.72500												
5099	.73750												
5100	469.75000												
5101	.76250												
5102	.77500												
5103	.78750												
5104	.80000												
5105	.81250												
5106	.82500												
5107	.83750												
5108	.85000												
5109	.86250												
5110	.87500												
5111	.88750												
5112	.90000												
5113	.91250												
5114	.92500												
5115	.93750												
5116	.95000												
5117	.96250												
5118	.97500												
5119	.98750												
5120	470.00000												

3 REVISION HISTORY

ISSUE	DATE	REVISION
-------	------	----------

1	September 98	Issue 1
---	--------------	---------

This Page Intentionally Left Blank.