

ONE PART

passion

TWO PARTS

science

**2008
CONDENSED CATALOG
& PRICE LIST**

Effective April 1, 2008





At Structural Concepts, we are passionate about the design and manufacture of food and floral display cases for the supermarket, foodservice and convenience store markets. Our temperature controlled merchandisers will help you dramatically increase sales of fresh baked goods, delicious deli products, garden-fresh produce and other specialty items! No where else will you find such a broad offering of refrigerated air screen and unique combination cases designed to meet a variety of display needs. And, our on-going advancements in technology make our cases easy to own and operate for years of trouble-free service.



888 E. Porter Road
Muskegon, MI 49441

Toll Free 800-433-9489
Phone 231-798-8888
Fax 231-798-4960

www.structuralconcepts.com



Many prestigious organizations within the foodservice industry have honored Structural Concepts for our leadership role in innovative technology development.

General Information

| | |
|-----------------------------------|-------|
| Quick Ship & Express3 Models..... | 10-11 |
| Accessories & Options | 76-77 |
| Foodservice Representatives..... | 78-79 |
| Master Service Agents..... | 80-83 |
| Warranty and Terms | 84 |
| Factory Contact Information | 85 |

Encore®

A bakery merchandising system that includes high-volume display cases in a large variety of styles and sizes, including service, self-service and combination cases.

| | |
|-------------------------|-------|
| Combination Cases | 12-17 |
| Service Cases..... | 18-29 |
| Self-Service Cases..... | 30-34 |

Harmony®

A series of refrigerated service and combination bakery display cases that are less than 34" deep to fit through standard door openings.

| | |
|-------------------------|-------|
| Combination Cases | 35 |
| Service Cases..... | 36-37 |

Renaissance®

A series of mid-volume deli and bakery merchandisers designed with a smaller footprint than our high-volume Encore Series. Available in a variety of styles and sizes.

| | |
|----------------------------|-------|
| Service Bakery Cases | 38-40 |
| Service Deli Cases | 41-42 |
| Service Candy Cases | 43 |

Oasis®

A comprehensive offering of refrigerated and non-refrigerated open air-screen merchandisers in a variety of heights and sizes, including several combination cases.

| | |
|--|-------|
| Refrigerated Air Screen Cases..... | 44-49 |
| Non-Refrigerated Self-Service Cases..... | 50 |
| Combination Cases | 51-52 |

Fusion®

A series of deli and bakery merchandisers that includes refrigerated service and specialty combination display cases designed to integrate a variety of display merchandising applications.

| | |
|-----------------------------|-------|
| Service Deli Cases..... | 53-54 |
| Service Bakery Cases | 55-56 |
| Combination Cases | 57-63 |
| Work Counter Case..... | 64 |
| Self-Service Open Case..... | 65 |

Impulse®

A series of refrigerated, non-refrigerated and warm counter top merchandisers, including refrigerated service and air screen cases that drop into counters.

| | |
|--|-------|
| Self-Service Refrigerated Drop-In Cases | 66-68 |
| Service/Self-Service Non-Refrigerated Countertop Cases | 69-70 |
| Self-Service Non-Refrigerated Countertop Cases..... | 71 |

Addenda®

A series of non-refrigerated self-service upright wall merchandisers designed to compliment Encore cases. These cases support a variety of packaged and non-packaged product applications.

| | |
|--|-------|
| Upright Self-Service Pastry Cases | 72-73 |
| Upright Self-Service Pastry/Hard Roll Case..... | 74 |
| Upright Self-Service Shelving/Hard Roll Case | 75 |

It's the science behind the beauty that makes our cases really stand out.

We invest in research and development because you invest in refrigerated display cases. Our R&D team creates technology that provides a return on your investment. Most of our advancements are designed to extend maintenance intervals, simplify maintenance, or automate a maintenance process. We also create innovative ways to make our cases more useful, more flexible, and more customer friendly.

Breeze & Breeze-E

Owning a refrigerated display case shouldn't be hard work. That's the idea behind Structural Concepts' **Breeze™** refrigeration system. Breeze is an easier-to-maintain, truly slide-out refrigeration system. That's our science at its best. Then our passion to meet your needs inspired another idea. **NEW Breeze-E™**, the enhanced Breeze offering a quieter system for Type II environments, is an option available on select Oasis air screen cases. It's the same reliable Breeze, but better for warmer environments! Both Breeze and Breeze-E offer rugged reliability, unmatched ease of service, and superior temperature consistency.

Technology Overview: Clean Sweep™

Clean Sweep, an option available with Breeze and Breeze-E refrigeration systems, helps prevent costly breakdowns. The patent-pending Clean Sweep™ Automatic Condenser Coil Cleaner is an electronically controlled brush mechanism that automatically cleans dust and debris from the condenser coil.



Oversized condenser coil. Our oversized coil takes strain off the motor by increasing air flow and consumes less energy. That means a longer life for the refrigeration system and stronger performance overall. With the addition of our Clean Sweep® automatic condenser coil cleaner option, daily dust buildup is a thing of the past.



Breeze

Slide-out refrigeration. Breeze is the first system truly designed to slide out, making it quick and easy to maintain. Breeze replaces copper tubing, which can kink or break, with flexible synthetic hosing. Flexibility is the key: the system can slide in and out repeatedly without risk of refrigerant leaks or blockages. Breeze's components can be easily reached for cleaning or adjustment, no special tools needed. Rapid, simple service is, well, a Breeze.



Breeze's smart microprocessor recognizes ambient conditions and adjusts the defrost cycle automatically—longer when there's more ice on the coil and shorter when there's less. Defrosting "as needed" eliminates the ice buildup and fluctuating temperatures associated with mechanical time clock systems. The result is consistent temperatures—the key to product shelf life.



NEW Breeze-E

A "stronger" Breeze for warmer environments and quieter operation.



Breeze-E Is Type II Compliant

With Type II, your case will hold temperature even in warmer or more humid conditions. Is Breeze-E right for you? It depends on the environment in which the case will be used. Many foodservice environments call for Type II minimums based on the temperature and humidity level in which the case must operate. Selecting the right refrigeration system means less maintenance and reduced cost of ownership.

Type I — Optimal performance at or below 75°F with 55% relative humidity.

Type II — Optimal performance at or below 80°F with 60% relative humidity.

* Independent test lab results. Tests performed on SCC Oasis model C03660R with standard refrigeration package and new Breeze-E.

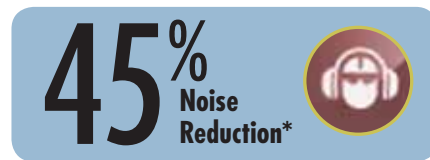

It's Quieter: Breeze-E Has Whisper Cool™

You have a lot of equipment in your operation, and all of it together creates an annoying background din. So when the market asked for quieter operation, Structural Concepts stepped up to the plate. New Whisper Cool technology is really something to shout about.

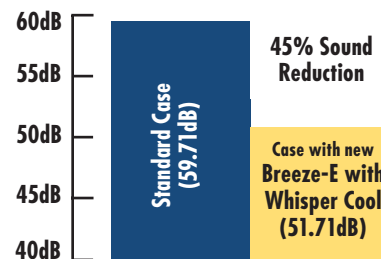

A reduction of 8 decibels results in a 45% reduction in sound.

Combination Cases

Single cases with multiple display areas that support different product temperatures and access options while optimizing precious floor space.



HOU4852R | See page 12 **Quick-Ship Express 3 Shipping**



HMBC4 | See page 35



HVLD56RSS | See page 15



HUDLR3852 | See page 13



HSL4850R | See page 17



H5C5650LR | See page 16 **Quick-Ship**



RB5C5948LR | See page 40

Many models include optional features and accessories. Refer to appropriate page for breakdown of standard and optional features.



COU2757R | See page 52

Quick-Ship



C3Z3667 | See page 51



FSGUCLR7257 | See page 58



FSP7242R.T1 | See page 62
With Rear Storage



FSP72 | See page 63
No Rear Storage



FSGUCLR48.T1 | See page 59



FSGUCLR7257 | See page 58

FS04837R | See page 64

FSGUCLR7254 | See page 60

Service Cases

Refrigerated, non-refrigerated and heated, glass enclosed display cases designed to enhance the presentation and stimulate sales of fresh food.



HV48R | See page 18 *Quick-Ship*



HMG3953R | See page 36 *Quick-Ship*



HMG5153 | See page 37



FSBG48R.T1 | See page 55



RT48 | See page 21



RTS48 | See page 22



DTSOW90
See page 27

DTSIW45
See page 26

DTP36
See page 28

RTSOW90
See page 24

RTS36
See page 22

Many models shown include optional features and accessories. Refer to appropriate page for breakdown of standard and optional features.



RBG4848R | See page 38



RBG5948 | See page 39



RCG4848R | See page 43



RDG7748W | See page 42



RDG5948R | See page 41



FSDG48R.T1 | See page 53



FSDG48W.T1 | See page 54



G24F | See page 29

Grab-n-Go Cases

Modular, flexible display cases with an open front for easy access to food. Internal refrigeration is maintained by an innovative front air curtain.



CO4778R | See page 44

Quick-Ship

Express³
Shipping



NEW
"Front Breathing"
Air Screen

B42 | See page 48

Quick-Ship



CO3660R | See page 45

Quick-Ship



HV56RSS | See page 30

Many models shown include optional features and accessories. Refer to appropriate page for breakdown of standard and optional features.



CO4748R | See page 46 



MP5348RSS | See page 49



HV3638RSS | See page 32



CO2739R | See page 47

Counter Cases

Glass enclosed and open reach-in display cases designed to set on or drop into counters.



D03623R | See page 67



D03616R | See page 68



D04837R | See page 66



CSC3223 | See page 71

Quick-Ship



CGC3830 | See page 70



CGS2830 | See page 69
(Case shown reversed – Self Service)

Many models shown include optional features and accessories. Refer to appropriate page for breakdown of standard and optional features.

Non-Refrigerated Cases

Self-service cases, for quick and easy customer selection.



PC7482 | See page 73



CSF4231 | See page 72

Quick-Ship



PHRM5682 | See page 74



SHRM5682 | See page 75



HVB74SS | See page 33



HVAD48SS | See page 34

Many models shown include optional features and accessories. Refer to appropriate page for breakdown of standard and optional features.

Express³ Shipping

Available to ship within **3** Business days

- Standard specifications listed below
- Black Exterior
- Black Interior
- Black Trim
- Designated by adding - E3 to models

Quick-Ship

Available to ship within **10** Business days

- Standard specifications listed below
- You choose:
 - Exterior color
 - End panel style (where applicable)
- Designated by adding - QS to models

Note: Must specify on purchase order if Express 3 or Quick-Ship models are requested. Commitments will be made on a first-come, first-serve basis and inventory may be limited while stock is being replenished.

ENCORE® Combo Service Above Self-Service Cases

PROGRAM SPECS

Black interior, black exterior, black trim, self-contained refrigeration, straight base, full end panels, 2"H display steps, clear glass rear sliding doors. (Top section not divided on HOU3852R).



| MODEL | List Price |
|-------------|------------|
| HOU3852R-E3 | \$15,693 |
| HOU4852R-E3 | \$16,693 |
| HOU5652R-E3 | \$17,861 |
| HOU7452R-E3 | \$19,259 |

OASIS® Refrigerated Air Screen Cases

PROGRAM SPECS

Black interior, black exterior, self-contained refrigeration, angled base, full end panels, four lighted shelves, casters.



| MODEL | List Price |
|------------|------------|
| C03678R-E3 | \$11,321 |
| C04778R-E3 | \$12,057 |
| C05978R-E3 | \$13,168 |
| C07178R-E3 | \$14,029 |

ENCORE® Combo Service Above Self-Service Cases

PROGRAM SPECS

Black interior, black trim, self-contained refrigeration, straight base, full end panels, 2"H display steps, clear glass rear sliding doors. (Top section not divided on HOU3852R).



| MUST SELECT | MODEL | List Price |
|-----------------|-------------|------------|
| Exterior color. | HOU3852R-QS | \$15,693 |
| | HOU4852R-QS | \$16,693 |
| | HOU5652R-QS | \$17,861 |
| | HOU7452R-QS | \$19,259 |



ENCORE® Combination Refrigerated Service Beside Non-Refrigerated Service Cases

PROGRAM SPECS

Black interior, black trim, self-contained refrigeration, straight base, clear glass rear sliding doors.



MUST SELECT

Exterior color, end panel style (full or cutaway)

| MODEL | List Price Full Ends | List Price Cutaway Ends |
|--------------|----------------------|-------------------------|
| H5C4850LR-QS | \$16,383 | \$17,563 |
| H5C6650LR-QS | \$17,123 | \$18,303 |
| H5C7450LR-QS | \$17,794 | \$18,974 |



ENCORE® Refrigerated Service Cases

PROGRAM SPECS

Black interior, black trim, self-contained refrigeration, straight base, clear glass rear sliding doors.

MUST SELECT

Exterior color, end panel style (full or cutaway)



| MODEL | List Price Full Ends | List Price Cutaway Ends |
|----------|----------------------|-------------------------|
| HV38R-QS | \$14,604 | \$15,784 |
| HV48R-QS | \$15,402 | \$16,582 |
| HV56R-QS | \$16,131 | \$17,311 |
| HV74R-QS | \$16,725 | \$17,905 |



HARMONY® Refrigerated Service Cases

PROGRAM SPECS

Black interior, black trim, self-contained refrigeration, straight base, clear glass rear sliding doors (HMG3953R-HMG7553R), one rear swinging door (HMG2653R).

MUST SELECT

Exterior color, end panel style (full or cutaway)

| MODEL | List Price Full Ends | List Price Cutaway Ends |
|-------------|----------------------|-------------------------|
| HMG2653R-QS | \$13,822 | \$15,002 |
| HMG3953R-QS | \$14,604 | \$15,784 |
| HMG5153R-QS | \$15,402 | \$16,582 |
| HMG6353R-QS | \$16,131 | \$17,311 |
| HMG7553R-QS | \$16,725 | \$17,905 |



OASIS® Refrigerated Air Screen Cases

PROGRAM SPECS

Black interior, self-contained refrigeration, four lighted shelves, angled base, casters.

MUST SELECT

Exterior color, end panel style (full or cutaway)

| MODEL | List Price Full Ends | List Price Cutaway Ends |
|------------|----------------------|-------------------------|
| C03678R-QS | \$11,321 | \$11,681 |
| C04778R-QS | \$12,057 | \$12,417 |
| C05978R-QS | \$13,168 | \$13,528 |
| C07178R-QS | \$14,029 | \$14,389 |



Quick-Ship

OASIS® Refrigerated Air Screen Cases

PROGRAM SPECS

Black interior, self-contained refrigeration, two lighted shelves, angled base, casters.

MUST SELECT

Exterior color, end panel style (full or cutaway)

| MODEL | List Price Full Ends | List Price Cutaway Ends |
|------------|----------------------|-------------------------|
| C03660R-QS | \$10,732 | \$11,092 |
| C04760R-QS | \$11,481 | \$11,841 |
| C05960R-QS | \$12,506 | \$12,866 |
| C07160R-QS | \$13,262 | \$13,622 |



Quick-Ship

OASIS® Refrigerated Air Screen Cases

PROGRAM SPECS

Black interior, self-contained refrigeration, two non-lighted shelves, angled base, casters.

MUST SELECT

Exterior color, end panel style (full or cutaway)

| MODEL | List Price Full Ends | List Price Cutaway Ends |
|------------|----------------------|-------------------------|
| C04748R-QS | \$10,346 | \$10,706 |



Quick-Ship

OASIS® 24"D Refrigerated Air Screen Case

PROGRAM SPECS

Black interior, self-contained refrigeration, four lighted shelves, casters.

MUST SELECT

Exterior laminate for header, front & end panels.

| MODEL | List Price |
|--------|------------|
| B32-QS | \$10,799 |
| B42-QS | \$11,500 |
| B62-QS | \$13,372 |
| B82-QS | \$17,680 |



Quick-Ship

OASIS® Combination Case

PROGRAM SPECS

Black interior, self-contained refrigeration, black shelving, top light and shelf light, clear glass rear doors.

MUST SELECT

Exterior color

| MODEL | List Price |
|-------------|------------|
| COU2757R-QS | \$11,153 |



Quick-Ship

IMPULSE® Non-Refrigerated Self-Service Countertop Case

PROGRAM SPECS

Black interior color and frame, solid back panel, gray base.

| MODEL | List Price |
|------------|------------|
| CSC3223-QS | \$3,515 |



Quick-Ship

ADDENDA® Self-Service Floor Case

PROGRAM SPECS

Black upper frame and interior, gray lower base, solid back panel.

| MODEL | List Price |
|------------|------------|
| CSF4231-QS | \$4,982 |



Quick-Ship

Quick-Ship Models

List price shown reflects model pricing based on features listed, non-premium laminate and end panel style. Cutaway list price reflects cost of two ends. Exterior color selection may add additional charges to the list price. Refer to specific model page of catalog to determine if exterior upcharge applies.

Contact Structural Concepts' Customer Service Department for additional information on specific model availability.

Combination Convertible Service Above Refrigerated Self-Service Case

Standard Features

- Breeze™ Refrigeration System (See page 1)
- Upper service display area
 - Baffle system converts display from refrigerated to non-refrigerated
 - Clear glass rear sliding doors
 - Curved single pane lift-up front glass
 - Adjustable clear glass shelf (15 3/4"D)
 - Upper level deck (20 3/8"D)
- Lower refrigerated self-service display area
 - Single display level consisting of bottom sheet metal deck (29 1/2"D)
 - Header light
- Two full end panels with mirror interior (lower section)
- T-8 top light and shelf lights
- 6' power cord
- Integrated average product temperature of 41°F
- ETL sanitation conforms to NSF 7
- ETL Listed Certified to CAN/CSA 22.2
- 1 year parts and labor; 5 year compressor warranty

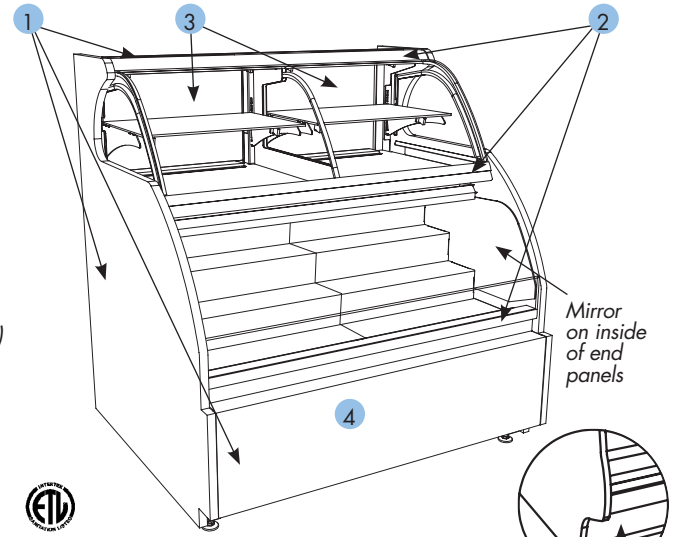

ETL
HOU5652R

Shown with optional display steps in lower display area.
NOTE: Upper display area in HOU3852R is not divided.

ABS base option

NOTE: Compressor air intake from rear and out front panel at toe kick.
Toe kick cannot be blocked.



| MODEL | HOU3852R | HOU4852R | HOU5652R | HOU7452R |
|------------|--------------------|--------------------|--------------------|--------------------|
| Dimensions | 40"L x 42"D x 53"H | 50"L x 42"D x 53"H | 58"L x 42"D x 53"H | 76"L x 42"D x 53"H |
| List \$ | \$15,143 | \$16,143 | \$17,311 | \$18,709 |

Dimensions shown are not exact. Refer to Factory Specification drawings for more detail.

| Product Specification | Standard (N/C) | Option(s) | List \$ |
|--|--|--|---|
| Interior Color* | Black | White Stainless Steel | N/C \$1,980 |
| Exterior Color* 1 | Choice of Wilsonart® or Formica® non-premium laminates | Wilsonart® or Formica® premium laminates (as noted in laminate charts) Other manufacturer's laminates Painted (applies only with ABS angled front panel) (specify color) Stainless Steel (straight front panel required) Oak veneer with clear sealer (straight front panel required) Oak veneer stained (straight front panel required) (color match required) | \$620 Call for quote N/C \$1,250 \$1,700 \$1,930 |
| Trim Color* 2 | Black | Silver Gold | N/C \$260 |
| Upper Rear* 3 | Clear glass sliding doors | Reflective glass sliding doors | \$260 |
| Front Panel Style* 4 | Straight front (laminated) | ABS upper front with angled lower (painted) (case is 3/4" less deep) | N/C |
| Base* | Levelers | Casters (not available with remote refrigeration)** | \$340 |
| Refrigeration* | Breeze™ self-contained w/ evaporator pan (rear air intake/front air discharge at toe kick) | Remote (compressor supplied by others) Pressure release valve (required for city of Chicago - must be ordered with case) | Call for quote \$50 |
| Miscellaneous (Must be chosen when case is ordered) | | Rear door lock Second year parts & labor warranty (excludes compressor) | \$210 \$530 |
| Accessories (Can be purchased at any time. Refer to pages 76/77 for information) | | Display steps for lower display (2" or 4"H) Lighted glass shelf for lower display (23 3/4"D) Rear wrapping board, 8"D Removable wire security cover, locking (for lower display, includes upper front glass lock) Night curtain, pull-down, non-locking | \$550 \$480 \$450 \$500 \$420 |

*Must choose one when placing order

**May increase height of case - refer to specification sheet

| MODEL | WEIGHT | Self-Contained Refrigeration/Dry | | | Remote Refrigeration with Leads | | |
|----------|--------|----------------------------------|-------|-----------|---------------------------------|------|-------|
| | | VOLTS | AMPS | NEMA PLUG | VOLTS | AMPS | BTUH |
| HOU3852R | 900 | 120/1/60 | 16.04 | 5-20P | 120/1/60 | 2.72 | 2,948 |
| HOU4852R | 1,050 | 220/1/60* | 13.92 | 14-20P | 120/1/60 | 3.42 | 3,431 |
| HOU5652R | 1,060 | 220/1/60* | 13.72 | 14-20P | 120/1/60 | 3.22 | 3,817 |
| HOU7452R | 1,220 | 220/1/60* | 18.12 | 14-30P | 120/1/60 | 4.12 | 4,900 |

Freight Class: 110 NOTE: Freight rate subject to linear foot rule.

*Requires three wires plus ground

Based on operating conditions of 75°F and 55% relative humidity.
Specifications and pricing subject to change without notice.

Combination Non-Refrigerated Service Above Refrigerated Self-Service Case

Standard Features

- Breeze™ Refrigeration System (See page 1)
- Upper non-refrigerated service display area
 - Clear glass rear sliding doors
 - Curved single pane lift-up front glass
 - Adjustable clear glass shelf (15 3/4"D)
 - Upper level deck (20 3/8"D)
- Lower refrigerated self-service display area
 - Single display level consisting of bottom sheet metal deck (29 1/2"D)
 - Top light
- Two full end panels with mirror interior (lower section)
- T-8 top light and shelf lights
- 6' power cord
- Integrated average product temperature of 41 °F
- ETL sanitation conforms to NSF 7
- ETL Listed Certified to CAN/CSA 22.2
- 1 year parts and labor; 5 year compressor warranty

NOTE: Compressor air intake from rear and out front panel at toe kick.
Toe kick cannot be blocked.

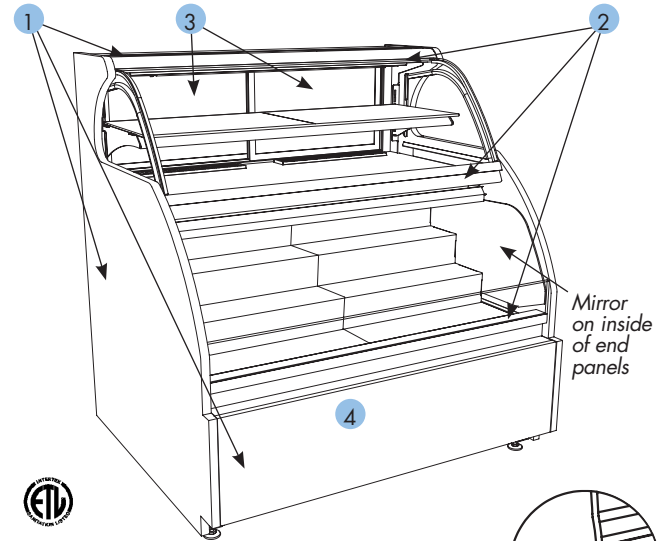

HUDLR5652

Shown with optional display steps in lower display area.
NOTE: Upper display area is not divided in HUDLR models.

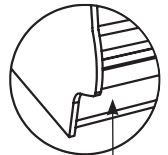

ABS base option

| MODEL | HUDLR3852 | HUDLR4852 | HUDLR5652 | HUDLR7452 |
|------------|--------------------|--------------------|--------------------|--------------------|
| Dimensions | 40"L x 42"D x 53"H | 50"L x 42"D x 53"H | 58"L x 42"D x 53"H | 76"L x 42"D x 53"H |
| List \$ | \$13,591 | \$14,117 | \$15,380 | \$16,610 |

Dimensions shown are not exact. Refer to Factory Specification drawings for more detail.

| Product Specification | Standard (N/C) | Option(s) | List \$ |
|---|---|--|---|
| Interior Color* | Black | White Stainless Steel | N/C \$1,980 |
| Exterior Color* ¹ | Choice of Wilsonart® or Formica® non-premium laminates | Wilsonart® or Formica® premium laminates (as noted in laminate charts) Other manufacturer's laminates Painted (applies only with ABS angled front panel) (specify color) Stainless Steel (straight front panel required) Oak veneer with clear sealer (straight front panel required) Oak veneer stained (straight front panel required) (color match required) | \$620 Call for quote N/C \$1,250 \$1,700 \$1,930 |
| Trim Color* ² | Black | Silver Gold | N/C \$260 |
| Upper Rear* ³ | Clear glass sliding doors | Reflective glass sliding doors | \$260 |
| Front Panel Style* ⁴ | Straight front (laminated) | ABS upper front with angled lower (painted) (case is 3/4" less deep) | N/C |
| Base* | Levelers | Castors (not available with remote refrigeration)** | \$340 |
| Refrigeration* | Breeze™ self-contained w/ evaporator pan (rear air intake/ front air discharge at toe kick) | Remote (compressor supplied by others) Pressure release valve (required for city of Chicago - must be ordered with case) | Call for quote \$50 |
| Miscellaneous (Must be chosen when case is ordered) | | Rear door lock Second year parts & labor warranty (excludes compressor) | \$210 \$530 |
| Accessories (Can be purchased at any time. Refer to pages 76/77 for information) | | Display steps for lower display (2" or 4"H) Lighted glass shelf for lower display (23 3/4"D) Rear wrapping board, 8"D Removable wire security cover, locking (for lower display, includes upper front glass lock) Night curtain, pull-down, non-locking | \$550 \$480 \$450 \$500 \$420 |

*Must choose one when placing order

**May increase height of case - refer to specification sheet.

| MODEL | WEIGHT | Self-Contained Refrigeration/Dry | | | Remote Refrigeration with Leads | | |
|-----------|--------|----------------------------------|-------|-----------|---------------------------------|------|-------|
| | | VOLTS | AMPS | NEMA PLUG | VOLTS | AMPS | BTUH |
| HUDLR3852 | 850 | 120/1/60 | 15.8 | 5-20P | 120/1/60 | 2.48 | 1,762 |
| HUDLR4852 | 900 | 220/1/60* | 13.1 | 14-20P | 120/1/60 | 2.6 | 2,565 |
| HUDLR5652 | 1,100 | 220/1/60* | 13.15 | 14-20P | 120/1/60 | 2.65 | 2,860 |
| HUDLR7452 | 1,150 | 220/1/60* | 17.86 | 14-30P | 120/1/60 | 3.86 | 3,738 |

Freight Class: 110 NOTE: Freight rate subject to linear foot rule. *Requires three wires plus ground

Based on operating conditions of 75°F and 55% relative humidity.
Specifications and pricing subject to change without notice.

Combination Refrigerated Service Above Refrigerated Self-Service Case

Standard Features

- Breeze™ Refrigeration System (See page 1)
- Upper refrigerated service display area
 - Clear glass rear sliding doors
 - Curved single pane lift-up front glass
 - Adjustable clear glass shelf (15 3/4"D)
 - Upper level deck (20 3/8"D)
- Lower refrigerated self-service display area
 - Single display level consisting of bottom sheet metal deck (29 1/2"D)
 - Top light
- Two full end panels with mirror interior (lower section)
- T-8 top light and shelf lights
- 6' power cord
- Integrated average product temperature of 41 °F
- ETL sanitation conforms to NSF 7
- ETL Listed Certified to CAN/CSA 22.2
- 1 year parts and labor; 5 year compressor warranty

NOTE: Compressor air intake from rear and out front panel at toe kick. Toe kick cannot be blocked.

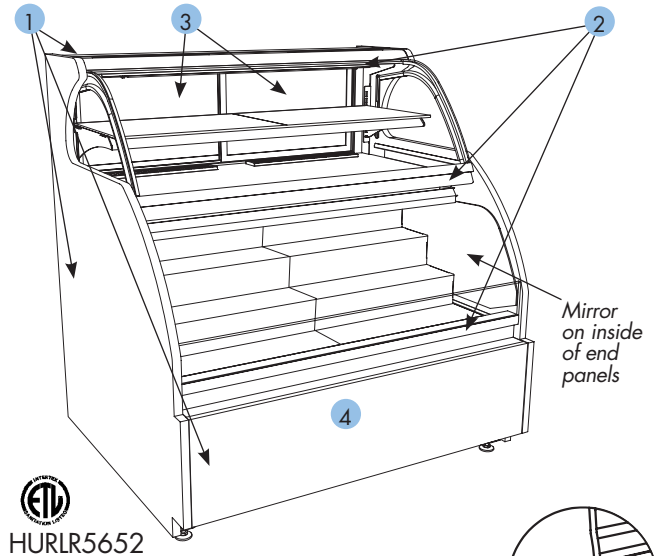

Shown with optional display steps in lower display area. NOTE: Upper display area is not divided in HURLR models.

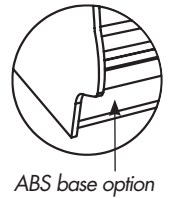

ABS base option

| MODEL | HURLR3852 | HURLR4852 | HURLR5652 | HURLR7452 |
|------------|--------------------|--------------------|--------------------|--------------------|
| Dimensions | 40"L x 42"D x 53"H | 50"L x 42"D x 53"H | 58"L x 42"D x 53"H | 76"L x 42"D x 53"H |
| List \$ | \$14,960 | \$16,077 | \$17,224 | \$18,629 |

Dimensions shown are not exact. Refer to Factory Specification drawings for more detail.

| Product Specification | Standard (N/C) | Option(s) | List \$ |
|--|--|--|---|
| Interior Color* | Black | White Stainless Steel | N/C \$1,980 |
| Exterior Color* 1 | Choice of Wilsonart® or Formica® non-premium laminates | Wilsonart® or Formica® premium laminates (as noted in laminate charts) Other manufacturer's laminates Painted (applies only with ABS angled front panel) (specify color) Stainless Steel (straight front panel required) Oak veneer with clear sealer (straight front panel required) Oak veneer stained (straight front panel required) (color match required) | \$620 Call for quote N/C \$1,250 \$1,700 \$1,930 |
| Trim Color* 2 | Black | Silver Gold | N/C \$260 |
| Upper Rear* 3 | Clear glass sliding doors | Reflective glass sliding doors | \$260 |
| Front Panel Style* 4 | Straight front (laminated) | ABS upper front with angled lower (painted) (case is 3/4" less deep) | N/C |
| Base* | Levelers | Casters (not available with remote refrigeration)** | \$340 |
| Refrigeration* | Breeze™ self-contained w/ evaporator pan (rear air intake/front air discharge at toe kick) | Remote (compressor supplied by others) Pressure release valve (required for city of Chicago) must be ordered with case | Call for quote \$50 |
| Miscellaneous (Must be chosen when case is ordered) | | Rear door lock Second year parts & labor warranty (excludes compressor) | \$210 \$530 |
| Accessories (Can be purchased at any time. Refer to pages 76/77 for information) | | Display steps for lower display (2" or 4"H) Lighted glass shelf for lower display (23 3/4"D) Rear wrapping board, 8"D Removable wire security cover, locking (for lower display, includes upper front glass lock) Night curtain, pull-down, non-locking | \$550 \$480 \$450 \$500 \$420 |

*Must choose one when placing order

**May increase height of case - refer to specification sheet

| MODEL | WEIGHT | Self-Contained Refrigeration/Dry | | | Remote Refrigeration with Leads | | |
|-----------|--------|----------------------------------|-------|-----------|---------------------------------|------|-------|
| | | VOLTS | AMPS | NEMA PLUG | VOLTS | AMPS | BTUH |
| HURLR3852 | 850 | 120/1/60 | 16.04 | 5-20P | 120/1/60 | 2.72 | 2,948 |
| HURLR4852 | 890 | 220/1/60* | 13.46 | 14-20P | 120/1/60 | 2.96 | 3,431 |
| HURLR5652 | 900 | 220/1/60* | 13.56 | 14-20P | 120/1/60 | 3.06 | 3,817 |
| HURLR7452 | 1,200 | 220/1/60* | 18.4 | 14-30P | 120/1/60 | 4.4 | 4,686 |

Freight Class: 110 NOTE: Freight rate subject to linear foot rule.

*Requires three wires plus ground

Based on operating conditions of 75°F and 55% relative humidity. Specifications and pricing subject to change without notice.

Combination Non-Refrigerated Service Beside Refrigerated Self-Service Case

Standard Features

- Breeze™ Refrigeration System (See page 1)
- Two full end panels with mirror interior
- T-8 top light and shelf lights
- 6' power cord
- Integrated average product temperature of 41°F
- ETL sanitation conforms to NSF 7
- ETL Listed Certified to CAN/CSA 22.2
- 1 year parts and labor, 5 year compressor warranty

Non-Refrigerated Service Side

- 3 adjustable clear glass shelves (24"D, 25"D, 26"D)
- Rear swing out door
- Curved single pane lift-up front glass

Refrigerated Self-Service Side

- 3 adjustable clear glass shelves (16"D, 20"D, 24"D)
- Bottom sheet metal deck

NOTE: Compressor air intake from rear and out front panel at toe kick. Toe kick cannot be blocked.

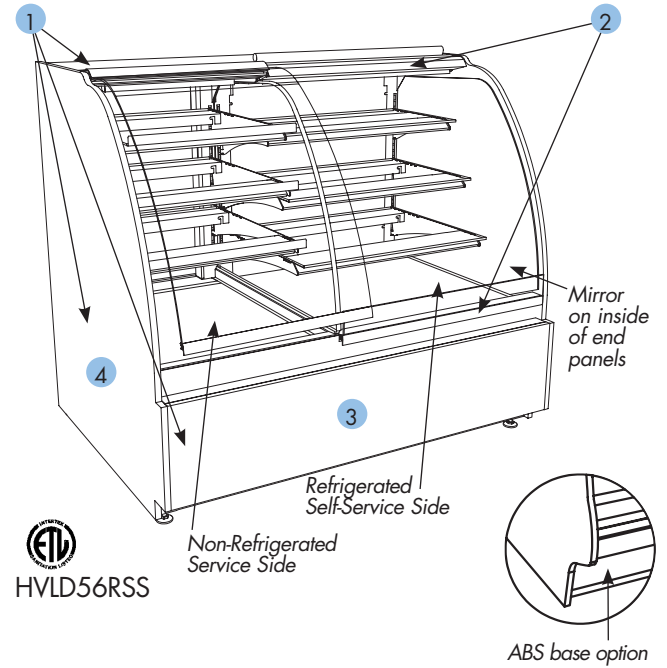

ETL
HVLD56RSS

ABS base option

| MODEL | HVLD48RSS | HVLD56RSS | HVLD74RSS |
|------------|--|--|--|
| Dimensions | 50"L x 42"D x 51"H (Dry 23.25"/Refrig 23.25") | 58"L x 42"D x 51"H (Dry 23.25"/Refrig 31.25") | 76"L x 42"D x 51"H (Dry 23.25"/Refrig 49.25") |
| List \$ | \$16,267 | \$17,232 | \$18,545 |

Dimensions shown are not exact. Refer to Factory Specification drawings for more detail.

| Product Specification | Standard (N/C) | Option(s) | List \$ |
|---|--|--|---|
| Interior Color* | Black | White Stainless Steel | N/C \$1,980 |
| Exterior Color* ¹ | Choice of Wilsonart® or Formica® non-premium laminates | Wilsonart® or Formica® premium laminates (as noted in laminate charts) Other manufacturer's laminates Painted (applies only with ABS angled front panel) (specify color) Stainless Steel (straight front panel required) Oak veneer with clear sealer (straight front panel required) Oak veneer stained (straight front panel required) (color match required) | \$620 Call for quote N/C \$1,250 \$1,700 \$1,930 |
| Trim Color* ² | Black | Silver Gold | N/C \$260 |
| Front Panel Style* ³ | Straight front (laminated) | ABS upper front with angled lower (painted) (case is 3/4" less deep) | N/C |
| End Panel Style* ⁴ | Full with mirror | Cutaway with glass Deduct end panel (for case to case lineups) | \$590/end -\$240/end |
| Base* | Levelers | Casters (not available with remote refrigeration)** | \$340 |
| Refrigeration* | Breeze™ self-contained w/ evaporator pan (rear air intake/front air discharge at toe kick) | Remote (compressor supplied by others) Pressure release valve (required for city of Chicago) must be ordered with case | Call for quote \$50 |
| Miscellaneous (Must be chosen when case is ordered) | | Front glass lock Second year parts & labor warranty (excludes compressor) | \$210 \$530 |
| Accessories (Can be purchased at any time. Refer to pages 76/77 for information) | | Removable wire security cover, locking (for refrigerated side) Night curtain, pull-down, non-locking | \$500 \$420 |

*Must choose one when placing order

**May increase height of case - refer to specification sheet

| MODEL | WEIGHT | Self-Contained Refrigeration/Dry | | | Remote Refrigeration with Leads | | |
|-----------|--------|----------------------------------|-------|-----------|---------------------------------|------|-------|
| | | VOLTS | AMPS | NEMA PLUG | VOLTS | AMPS | BTUH |
| HVLD48RSS | 970 | 220/1/60* | 12.33 | 14-20P | 120/1/60 | 2.63 | 3,130 |
| HVLD56RSS | 1,020 | 220/1/60* | 12.83 | 14-20P | 120/1/60 | 3.13 | 4,004 |
| HVLD74RSS | 1,150 | 220/1/60* | 13.58 | 14-20P | 120/1/60 | 3.08 | 5,318 |

Freight Class: 110

NOTE: Freight rate subject to linear foot rule.

*Requires three wires plus ground

Based on operating conditions of 75°F and 55% relative humidity. Specifications and pricing subject to change without notice.

Combination Refrigerated Service Beside Non-Refrigerated Service Case

Standard Features

- Breeze™ Refrigeration System (See page 1)
- Interior display area split 1/2 refrigerated and 1/2 non-refrigerated
- Three adjustable/removable clear glass shelves on each side (16"D, 20"D, 20"D)
- Two full end panels with mirror interior
- Clear glass rear sliding doors
- Curved single pane lift-up front glass
- Bottom sheet metal deck
- T-8 top light and shelf lights
- 6' power cord
- Integrated average product temperature of 41°F
- UL Certified to NSF Standard 7
- 1 year parts and labor; 5 year compressor warranty

NOTE: Compressor air intake from rear and out front panel at toe kick. Toe kick cannot be blocked.

Quick-Ship
See page 10

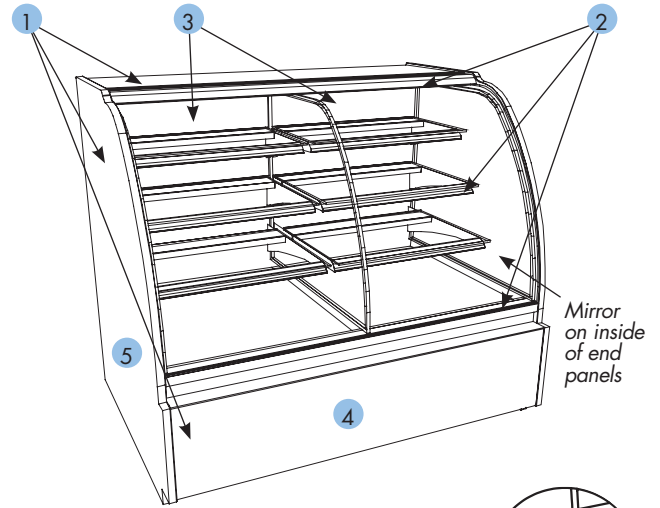

H5C7450LR

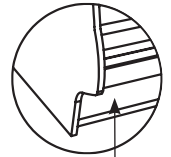

ABS base option

| MODEL** | H5C4850LR/H5C4850RR | H5C5650LR/H5C5650RR | H5C7450LR/H5C7450RR |
|------------|---------------------|---------------------|---------------------|
| Dimensions | 50"L x 42"D x 51"H | 58"L x 42"D x 51"H | 76"L x 42"D x 51"H |
| List \$ | \$16,383 | \$17,123 | \$17,794 |

**From customer side (LR=left refrig/RR=right refrig)
Dimensions shown are not exact. Refer to Factory Specification drawings for more detail.

| Product Specification | Standard (N/C) | Option(s) | List \$ |
|--|---|--|---|
| Interior Color* | Black | White Stainless Steel | N/C \$1,980 |
| Exterior Color* ¹ | Choice of Wilsonart® or Formica® non-premium laminates | Wilsonart® or Formica® premium laminates (as noted in laminate charts) Other manufacturer's laminates Painted (applies only with ABS angled front panel) (specify color) Stainless Steel (straight front panel required) Oak veneer with clear sealer (straight front panel required) Oak veneer stained (straight front panel required) (color match required) | \$620 Call for quote N/C \$1,250 \$1,700 \$1,930 |
| Trim Color* ² | Black | Silver Gold | N/C \$260 |
| Upper Rear* ³ | Clear glass sliding door | Reflective glass sliding doors | \$260 |
| Front Panel Style* ⁴ | Straight front (laminated) | ABS upper front with angled lower (painted) (case is 3/4" less deep) | N/C |
| End Panel Style* ⁵ | Full with mirror | Cutaway with glass Deduct end panel (for case to case lineups) | \$590/end -\$240/end |
| Base* | Levelers | Castors (not available with remote refrigeration)** | \$340 |
| Refrigeration* | Breeze™ self-contained w/ evaporator pan (rear air intake/ front air discharge at toe kick) | Remote (compressor supplied by others) Pressure release valve (required for city of Chicago) must be ordered with case | Call for quote \$50 |
| Miscellaneous (Must be chosen when case is ordered) | | Rear door lock Front glass lock Second year parts & labor warranty (excludes compressor) | \$210 \$210 \$530 |

*Must choose one when placing order

**May increase height of case - refer to specification sheet

| MODEL | WEIGHT | Self-Contained Refrigeration/Dry | | | Remote Refrigeration with Leads | | |
|--------------|--------|----------------------------------|-------|-----------|---------------------------------|------|-------|
| | | VOLTS | AMPS | NEMA PLUG | VOLTS | AMPS | BTUH |
| H5C4850LR&RR | 950 | 120/1/60 | 11.13 | 5-15P | 120/1/60 | 3.13 | 1,412 |
| H5C5650LR&RR | 1,030 | 120/1/60 | 12.13 | 5-15P | 120/1/60 | 4.13 | 1,655 |
| H5C7450LR&RR | 1,220 | 120/1/60 | 11.37 | 5-15P | 120/1/60 | 3.37 | 2,069 |

Freight Class: 110 NOTE: Freight rate subject to linear foot rule.

Based on operating conditions of 75°F and 55% relative humidity. Specifications and pricing subject to change without notice.

Combination Non-Refrigerated Service Above Refrigerated Service Case

Standard Features

- Breeze™ Refrigeration System (See page 1)
- Split interior display area, upper non-refrigerated, lower refrigerated
- Two full end panels with mirror interior
- Clear glass rear sliding doors (upper and lower)
- Bottom sheet metal deck
- Curved single pane lift-up front glass
- T-8 top light and shelf lights
- 6' power cord
- Integrated average product temperature of 41°F
- UL Certified to NSF Standard 7
- 1 year parts and labor; 5 year compressor warranty

NOTE: Compressor air intake from rear and out front panel at toe kick.
Toe kick cannot be blocked.

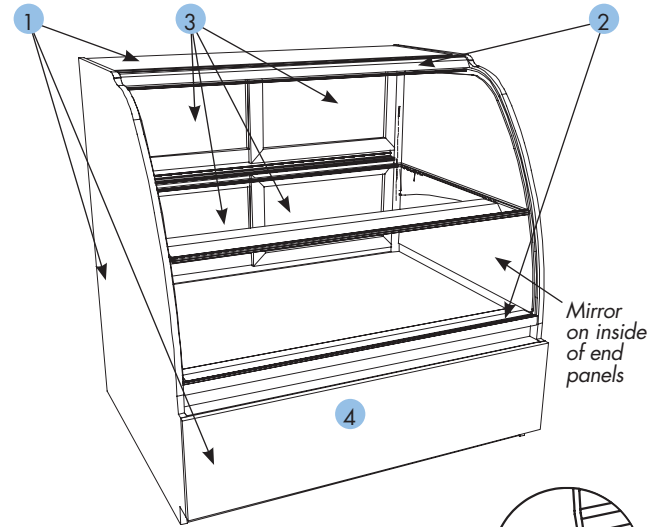

HSL4850R

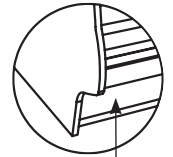

ABS base option

| MODEL | HSL3850R | HSL4850R |
|------------|--------------------|--------------------|
| Dimensions | 40"L x 42"D x 51"H | 50"L x 42"D x 51"H |
| List \$ | \$15,637 | \$16,397 |

Dimensions shown are not exact. Refer to Factory Specification drawings for more detail.

| Product Specification | Standard (N/C) | Option(s) | List \$ |
|--|---|--|---|
| Interior Color* | Black | White Stainless Steel | N/C \$1,980 |
| Exterior Color* ¹ | Choice of Wilsonart® or Formica® non-premium laminates | Wilsonart® or Formica® premium laminates (as noted in laminate charts) Other manufacturer's laminates Painted (applies only with ABS angled front panel) (specify color) Stainless Steel (straight front panel required) Oak veneer with clear sealer (straight front panel required) Oak veneer stained (straight front panel required) (color match required) | \$620 Call for quote N/C \$1,250 \$1,700 \$1,930 |
| Trim Color* ² | Black | Silver Gold | N/C \$260 |
| Shelving* | None (upper and lower areas) | Lighted glass shelf in lower refrigerated display (19 3/4"D) Lighted glass shelf in upper non-refrigerated display area (19 3/4"D) | \$290 \$290 |
| Upper and Lower Rear* ³ | Clear glass sliding doors | Reflective glass sliding doors | \$260 |
| Front Panel Style* ⁴ | Straight front (laminated) | ABS upper front with angled lower (painted) (case is 3/4" less deep) | N/C |
| Base* | Levelers | Casters (not available with remote refrigeration)** | \$340 |
| Refrigeration* | Breeze™ self-contained w/ evaporator pan (rear air intake/ front air discharge at toe kick) | Remote (compressor supplied by others) Pressure release valve (required for city of Chicago) must be ordered with case | Call for quote \$50 |
| Miscellaneous (Must be chosen when case is ordered) | | Rear door lock (for both sets of doors) Front glass lock Second year parts & labor warranty (excludes compressor) | \$420 \$210 \$530 |

*Must choose one when placing order

**May increase height of case - refer to specification sheet

| MODEL | WEIGHT | Self-Contained Refrigeration/Dry | | | Remote Refrigeration with Leads | | |
|----------|--------|----------------------------------|-------|-----------|---------------------------------|------|-------|
| | | VOLTS | AMPS | NEMA PLUG | VOLTS | AMPS | BTUH |
| HSL3850R | 850 | 120/1/60 | 10.37 | 5-15P | 120/1/60 | 2.37 | 1,350 |
| HSL4850R | 880 | 120/1/60 | 10.37 | 5-15P | 120/1/60 | 2.37 | 1,477 |

Freight Class: 110 NOTE: Freight rate subject to linear foot rule.

Based on operating conditions of 75°F and 55% relative humidity.
Specifications and pricing subject to change without notice.

Refrigerated Service Case

Standard Features

- Breeze™ Refrigeration System (See page 1)
- Three adjustable/removable clear glass shelves (16"D, 20"D, 20"D)
- Two full end panels with mirror interior
- Curved single pane lift-up front glass
- Bottom sheet metal deck
- T-8 top light and shelf lights
- 6' power cord
- Integrated average product temperature of 41°F
- ETL sanitation conforms to NSF 7
- ETL Listed Certified to CAN/CSA 22.2
- 1 year parts and labor; 5 year compressor warranty

NOTE: Compressor air intake from rear and out front panel at toe kick. Toe kick cannot be blocked.

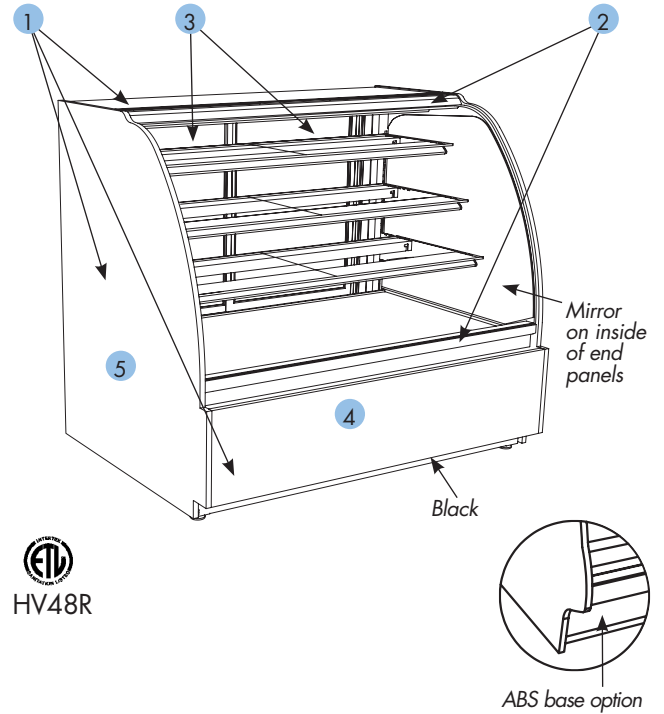

Quick-Ship
See page 10

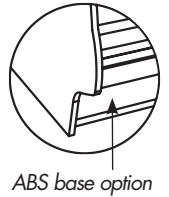

| MODEL | HV38R | HV48R | HV56R | HV74R | HV96R |
|------------|--------------------|--------------------|--------------------|--------------------|--------------------|
| Dimensions | 40"L x 42"D x 51"H | 50"L x 42"D x 51"H | 58"L x 42"D x 51"H | 76"L x 42"D x 51"H | 98"L x 42"D x 51"H |
| List \$ | \$14,604 | \$15,402 | \$16,131 | \$16,725 | \$22,871 |

Dimensions shown are not exact. Refer to Factory Specification drawings for more detail.

| Product Specification | Standard (N/C) | Option(s) | List \$ |
|---|--|--|---|
| Interior Color* | Black | White Stainless Steel | N/C \$1,980 |
| Exterior Color* ¹ | Choice of Wilsonart® or Formica® non-premium laminates | Wilsonart® or Formica® premium laminates (as noted in laminate charts) Other manufacturer's laminates Painted (applies only with ABS angled front panel) (specify color) Stainless Steel (straight front panel required) Oak veneer with clear sealer (straight front panel required) Oak veneer stained (straight front panel required) (color match required) | \$620 Call for quote N/C \$1,250 \$1,700 \$1,930 |
| Trim Color* ² | Black | Silver Gold | N/C \$260 |
| Upper Rear* ³ | Clear glass sliding doors | Reflective glass sliding doors | \$260 |
| Front Panel Style* ⁴ | Straight front (laminated) | ABS upper front with angled lower (painted) (case is 3/4" less deep) | N/C |
| End Panel Style* ⁵ | Full with mirror | Cutaway with glass Case to case glass end Deduct end panel (for case to case lineups) | \$590/end -\$100/end -\$240/end |
| Base* | Levelers | Casters (not available with remote refrigeration)** | \$340 |
| Refrigeration* | Breeze™ self-contained w/ evaporator pan (rear air intake/front air discharge at toe kick) | Remote (compressor supplied by others) Pressure release valve (required for city of Chicago) must be ordered with case | Call for quote \$50 |
| Miscellaneous (Must be chosen when case is ordered) | | Rear door lock Front glass lock Second year parts & labor warranty (excludes compressor) | \$210 \$210 \$530 |

*Must choose one when placing order

**May increase height of case - refer to specification sheet

| MODEL | WEIGHT | Self-Contained Refrigeration/Dry | | | Remote Refrigeration with Leads | | |
|-------|--------|----------------------------------|-------|-----------|---------------------------------|------|-------|
| | | VOLTS | AMPS | NEMA PLUG | VOLTS | AMPS | BTUH |
| HV38R | 800 | 120/1/60 | 10.12 | 5-15P | 120/1/60 | 2.12 | 2,445 |
| HV48R | 960 | 120/1/60 | 12.15 | 5-15P | 120/1/60 | 2.82 | 2,844 |
| HV56R | 1,020 | 120/1/60 | 12.17 | 5-15P | 120/1/60 | 2.47 | 3,289 |
| HV74R | 1,230 | 220/1/60* | 14.5 | 14-20P | 120/1/60 | 4 | 3,832 |
| HV96R | 1,480 | 220/1/60* | 14.8 | 14-20P | 120/1/60 | 4.3 | 4,920 |

Freight Class: 110 NOTE: Freight rate subject to linear foot rule.

*Requires three wires plus ground

Based on operating conditions of 75°F and 55% relative humidity. Specifications and pricing subject to change without notice.

Non-Refrigerated Service Case

Standard Features

- Three adjustable/removable wire shelves (20"D, 26"D, 26"D)
- Two full end panels with mirror interior
- Curved single pane lift-up front glass
- Bottom sheet metal deck
- T-8 top light and shelf lights
- 12" power cord
- ETL sanitation conforms to NSF 2
- ETL Listed Certified to CAN/CSA 22.2
- 1 year parts and labor warranty

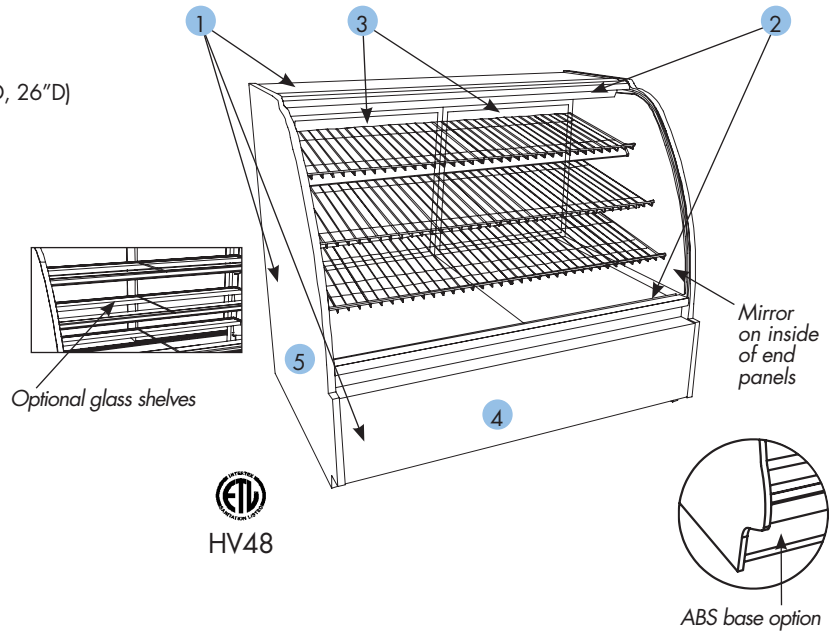

| MODEL | HV38 | HV48 | HV56 | HV74 |
|------------|--------------------|--------------------|--------------------|--------------------|
| Dimensions | 40"L x 42"D x 51"H | 50"L x 42"D x 51"H | 58"L x 42"D x 51"H | 76"L x 42"D x 51"H |
| List \$ | \$9,605 | \$9,692 | \$9,906 | \$11,075 |

Dimensions shown are not exact. Refer to Factory Specification drawings for more detail.

| Product Specification | Standard (N/C) | Option(s) | List \$ |
|--|--|--|---|
| Interior Color* | Black | White Stainless Steel | N/C \$1,980 |
| Exterior Color* ¹ | Choice of Wilsonart® or Formica® non-premium laminates | Wilsonart® or Formica® premium laminates (as noted in laminate charts) Other manufacturer's laminates Painted (applies only with ABS angled front panel) (specify color) Stainless Steel (straight front panel required) Oak veneer with clear sealer (straight front panel required) Oak veneer stained (straight front panel required) (color match required) | \$620 Call for quote N/C \$1,250 \$1,700 \$1,930 |
| Trim Color* ² | Black | Silver Gold | N/C \$260 |
| Shelving* | Wire racks | Glass Shelves | \$300 |
| Upper Rear* ³ | Clear glass sliding doors | Reflective glass sliding doors | \$260 |
| Front Panel Style* ⁴ | Straight front (laminated) | ABS upper front with angled lower (painted) (case is 3/4" less deep) | N/C |
| End Panel Style* ⁵ | Full with mirror | Cutaway with glass Case to case glass end Deduct end panel (for case to case lineups) | \$590/end -\$100/end -\$240/end |
| Base* | Levelers | Casters** | \$340 |
| Miscellaneous (Must be chosen when case is ordered) | | Rear door lock Front glass lock Second year parts & labor warranty | \$210 \$210 \$530 |

*Must choose one when placing order

**May increase height of case - refer to specification sheet

| TRAY CAPACITY | HV38* | HV48* | HV56* | HV74* |
|--------------------|-----------------|-----------------|-----------------|-----------------|
| Top shelf, 20"D | (3) 12x18 trays | (4) 12x18 trays | (5) 12x18 trays | (6) 12x18 trays |
| Second shelf, 26"D | (2) 18x26 trays | (2) 18x26 trays | (3) 18x26 trays | (4) 18x26 trays |
| Third shelf, 26"D | (2) 18x26 trays | (2) 18x26 trays | (3) 18x26 trays | (4) 18x26 trays |
| Deck, 29"D | (2) 18x26 trays | (2) 18x26 trays | (3) 18x26 trays | (4) 18x26 trays |

*Trays not supplied with unit

| MODEL | WEIGHT | Self-Contained Refrigeration/Dry | | |
|-------|--------|----------------------------------|------|-----------|
| | | VOLTS | AMPS | NEMA PLUG |
| HV38 | 700 | 120/1/60 | 0.62 | 5-15P |
| HV48 | 750 | 120/1/60 | 1.12 | 5-15P |
| HV56 | 750 | 120/1/60 | 1.12 | 5-15P |
| HV74 | 980 | 120/1/60 | 2.12 | 5-15P |

Freight Class: 125 NOTE: Freight rate subject to linear foot rule.

Based on operating conditions of 75°F and 55% relative humidity. Specifications and pricing subject to change without notice.

Refrigerated Service Candy Case

Standard Features

- Breeze™ Refrigeration System (See page 1)
- Three adjustable/removable clear glass shelves (16"D, 20"D, 20"D)
- Two full end panels with mirror interior
- Curved single pane lift-up front glass
- T-8 top light and shelf lights
- 6' power cord
- Integrated average product temperature of 65°F
- ETL sanitation conforms to NSF 7
- ETL Listed Certified to CAN/CSA 22.2
- 1 year parts and labor; 5 year compressor warranty

NOTE: Compressor air intake from rear and out front panel at toe kick. Toe kick cannot be blocked.

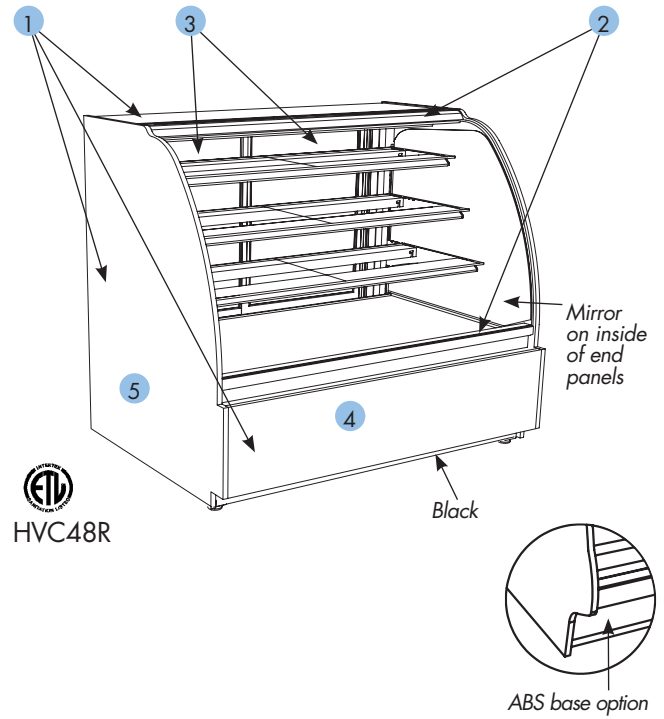

| MODEL | HVC38R | HVC48R |
|------------|---------------------|---------------------|
| Dimensions | 40"L x 42"D x 51" H | 50"L x 42"D x 51" H |
| List \$ | \$13,570 | \$14,337 |

Dimensions shown are not exact. Refer to Factory Specification drawings for more detail.

| Product Specification | Standard (N/C) | Option(s) | List \$ |
|---|--|--|---|
| Interior Color* | Black | White Stainless Steel | N/C \$1,980 |
| Exterior Color* 1 | Choice of Wilsonart® or Formica® non-premium laminates | Wilsonart® or Formica® premium laminates (as noted in laminate charts) Other manufacturer's laminates Painted (applies only with ABS angled front panel) (specify color) Stainless Steel (straight front panel required) Oak veneer with clear sealer (straight front panel required) Oak veneer stained (straight front panel required) (color match required) | \$620 Call for quote N/C \$1,250 \$1,700 \$1,930 |
| Trim Color* 2 | Black | Silver Gold | N/C \$260 |
| Upper Rear* 3 | Clear glass sliding doors | Reflective glass sliding doors | \$260 |
| Front Panel Style* 4 | Straight front (laminated) | ABS upper front with angled lower (painted) (case is 3/4" less deep) | N/C |
| End Panel Style* 5 | Full with mirror | Cutaway with glass Case to case glass end Deduct end panel (for case to case lineups) | \$590/end -\$100/end -\$240/end |
| Base* | Levelers | Castors (not available with remote refrigeration)** | \$340 |
| Refrigeration* | Breeze™ self-contained w/ evaporator pan (rear air intake/front air discharge at toe kick) | Remote (compressor supplied by others) Pressure release valve (required for city of Chicago) must be ordered with case | Call for quote \$50 |
| Miscellaneous (Must be chosen when case is ordered) | | Rear door lock Front glass lock Second year parts & labor warranty (excludes compressor) | \$210 \$210 \$530 |

*Must choose one when placing order

**May increase height of case - refer to specification sheet

| MODEL | WEIGHT | Self-Contained Refrigeration/Dry | | | Remote Refrigeration with Leads | | |
|--------|--------|----------------------------------|------|-----------|---------------------------------|-----------------|-------|
| | | VOLTS | AMPS | NEMA PLUG | VOLTS | AMPS | BTUH |
| HVC38R | 850 | 120/1/60 | 7.65 | 5-15P | 120/1/60 | 1.2 | 1,097 |
| HVC48R | 850 | 120/1/60 | 8.05 | 5-15P | 120/1/60 | Contact Factory | |

Freight Class: 110 NOTE: Freight rate subject to linear foot rule.

Based on operating conditions of 75°F and 55% relative humidity. Specifications and pricing subject to change without notice.

Refrigerated Display Table-Straight Front Glass

Standard Features

- Breeze™ Refrigeration System (See page 1)
- Two end panels
- Straight single pane front, top and end glass
- Open upper rear
- Non-refrigerated rear storage
- Straight laminated front panels
- 6' power cord
- Integrated average product temperature of 41°F
- ETL sanitation conforms to NSF 7
- 1 year parts and labor; 5 year compressor warranty

NOTE: Compressor air intake from rear and out front panel at toe kick. Toe kick cannot be blocked.

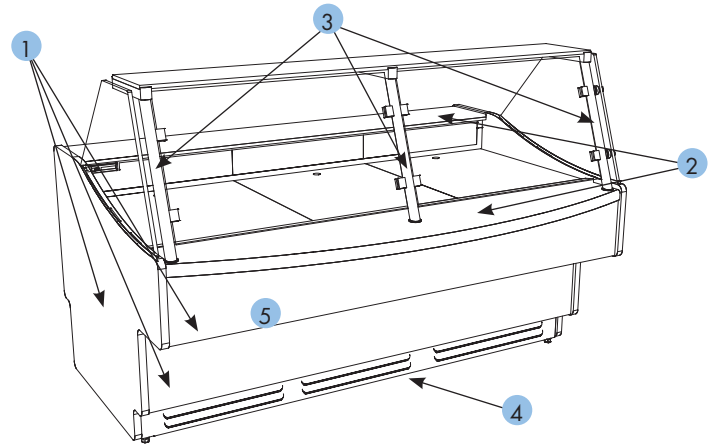

RT72

| MODEL | RT48 | RT72 | RT96 |
|------------|--------------------|--------------------|---------------------|
| Dimensions | 51"L x 51"D x 50"H | 75"L x 51"D x 50"H | 100"L x 51"D x 50"H |
| List \$ | \$24,789 | \$31,935 | \$35,496 |

Dimensions shown are not exact. Refer to Factory Specification drawings for more detail.

| Product Specification | Standard (N/C) | Option(s) | List \$ |
|--|---|---|------------------------------------|
| Interior Color* | Black | White Stainless Steel | N/C \$1,980 |
| Exterior Color* ¹ | Choice of Wilsonart® or Formica® non-premium laminates | Wilsonart® or Formica® premium laminates (as noted in laminate charts) Other manufacturer's laminates Stainless Steel | \$620 Call for quote \$1,250 |
| Interior display, front and rear ledge* ² | Corian® solid surface - Black Night Sky | Solid surface - special colors (may increase lead time) | Call for quote |
| Front glass posts* ³ | Black | Silver | N/C |
| Back Panel* | Solid back - White | Black | N/C |
| Toe Kick* ⁴ | Black | Stainless Steel White | \$250 N/C |
| Lights | None | LED Top Lighting 48" LED Top Lighting 72" LED Top Lighting 96" | \$1,410 \$1,690 \$1,970 |
| Front Panel Style* ⁵ | Straight front | Curved front (follows shape of curved front ledge) | \$370 |
| Refrigeration* | Breeze™ self-contained w/ evaporator pan (rear air intake/ front air discharge at toe kick) | Remote (compressor supplied by others) Pressure release valve (required for city of Chicago) must be ordered with case | Call for quote \$50 |
| Miscellaneous (Must be chosen when case is ordered) | | Second year parts & labor warranty (excludes compressor) | \$530 |

*Must choose one when placing order

| MODEL | WEIGHT | Self-Contained Refrigeration/Dry | | | Remote Refrigeration with Leads | | |
|-------|--------|----------------------------------|-------|-----------|---------------------------------|------|-------|
| | | VOLTS | AMPS | NEMA PLUG | VOLTS | AMPS | BTUH |
| RT48 | 1,200 | 120/1/60 | 14.56 | 5-15P | 120/1/60 | 1.26 | 2,482 |
| RT72 | 1,270 | 220/1/60* | 14.34 | 14-20P | 120/1/60 | 1.84 | 3,639 |
| RT96 | 1,750 | 220/1/60* | 12.87 | 14-20P | 120/1/60 | 1.97 | 4,611 |

Freight Class: 110 NOTE: Freight rate subject to linear foot rule.

*Requires three wires plus ground

Based on operating conditions of 75°F and 55% relative humidity. Specifications and pricing subject to change without notice.

Refrigerated Display Table - Curved Front Glass

Standard Features

- Breeze™ Refrigeration System (See page 1)
- One refrigerated display level
- Two end panels
- Curved single pane fixed front glass
- Straight laminated front panel
- 6' power cord
- Integrated average product temperature of 41°F
- ETL sanitation conforms to NSF 7
- ETL Listed Certified to CAN/CSA 22.2
- 1 year parts and labor, 5 year compressor warranty

NOTE: Compressor air intake through rear and out front panel. Toe kick cannot be blocked.

NOTE: Floor plan required.

NOTE: Front glass and solid surface material shipped loose. Must be installed after case is positioned in place.

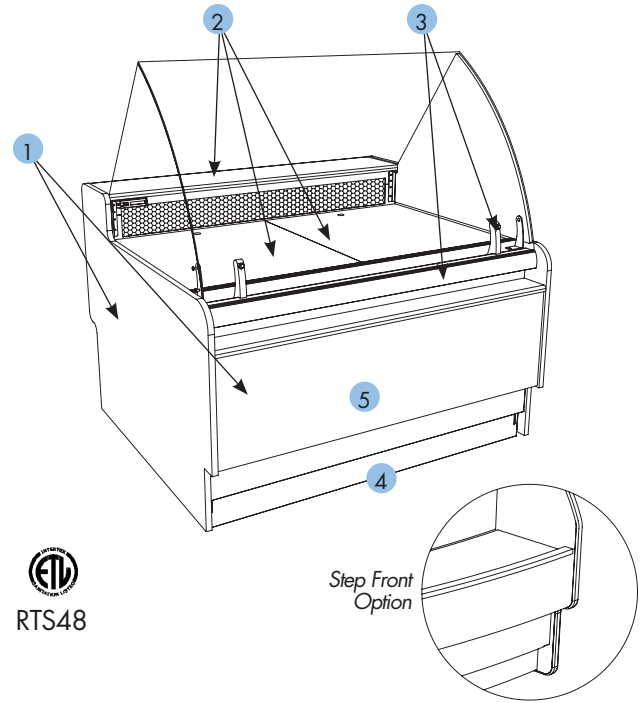

Step Front Option

| MODEL | RTS36 | RTS48 | RTS60 |
|------------|-------------------------|-------------------------|-------------------------|
| Dimensions | 39"L x 44 1/2"D x 54"H* | 51"L x 44 1/2"D x 54"H* | 63"L x 44 1/2"D x 54"H* |
| List \$ | \$22,615 | \$25,781 | \$29,390 |

*To top of glass
Dimensions shown are not exact. Refer to Factory Specification drawings for more detail.

| Product Specification | Standard (N/C) | Option(s) | List \$ |
|--|---|---|------------------------------------|
| Interior Color* | Black | White Stainless Steel | N/C \$1,980 |
| Exterior Color* ¹ | Choice of Wilsonart® or Formica® non-premium laminates | Wilsonart® or Formica® premium laminates (as noted in laminate charts) Other manufacturer's laminates Stainless Steel | \$620 Call for quote \$1,250 |
| Front Glass Posts* ³ | Black | Silver | N/C |
| End Panel* | Solid end with glass upper | Case to case glass end Deduct end panel (for case to case lineups) | -\$100/end -\$240/end |
| Back Panel* | Solid back - White | Black Stainless Steel | N/C \$1,200 |
| Front Panel Style* ⁵ | Straight front | Step front (increases depth of unit 10") | \$600 |
| Interior display, front & rear ledge* ² | Corian® solid surface - Black Night Sky | Solid surface - special colors (may increase lead time) | Call for quote |
| Base* | Levelers | Casters (not available with remote refrigeration)** 6"H legs (increases height of case 6") | \$340 \$350 |
| Toe Kick* ⁴ | Black | Stainless Steel White | \$250 N/C |
| Refrigeration* | Breeze™ self-contained w/ evaporator pan (rear air intake/ front air discharge at toe kick) | Remote (compressor supplied by others) Pressure release valve (required for city of Chicago) must be ordered with case | Call for quote \$50 |
| Miscellaneous (Must be chosen when case is ordered) | | Clean Sweep™ automatic condenser coil cleaner Second year parts & labor warranty (excludes compressor) | \$990 \$530 |

*Must choose one when placing order

**May increase height of case - refer to specification sheet

| MODEL | WEIGHT | Self-Contained Refrigeration/Dry | | | Remote Refrigeration with Leads | | |
|-------|--------|----------------------------------|-------|-----------|---------------------------------|------|-------|
| | | VOLTS | AMPS | NEMA PLUG | VOLTS | AMPS | BTUH |
| RTS36 | 1,200 | 120/1/60 | 16.16 | 5-20P | 120/1/60 | .54 | 1,708 |
| RTS48 | 1,200 | 120/1/60 | 14.81 | 5-20P | 120/1/60 | .59 | 2,392 |
| RTS60 | 1,250 | 120/1/60 | 14.51 | 5-20P | 120/1/60 | .59 | 2,861 |

Freight Class: 110 NOTE: Freight rate subject to linear foot rule.

Based on operating conditions of 75°F and 55% relative humidity. Specifications and pricing subject to change without notice.

Refrigerated Inside Corner Display - Spherical Front Glass

Standard Features

- Non-refrigerated rear storage without doors
- No end panels
- Spherical single pane fixed front glass
- Straight laminated front panel
- Integrated average product temperature of 41 °F
- ETL sanitation conforms to NSF 7
- 1 year parts and labor warranty

NOTE: Floor plan required.

NOTE: Front glass and solid surface material shipped loose. Must be installed after case is positioned in place.

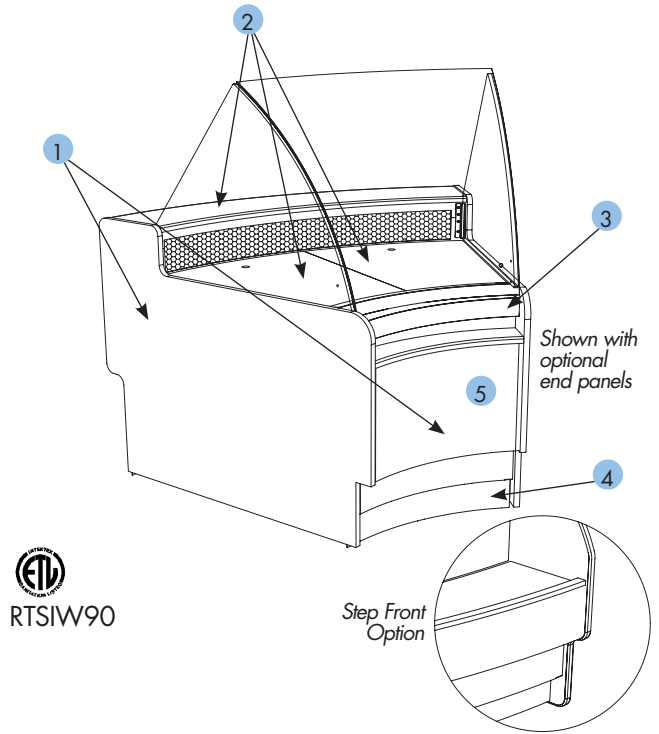

ETL
RTSIW90

| MODEL | RTSIW45 | RTSIW90 |
|------------|--------------------------|---------------------------|
| Dimensions | 56"L x 44 1/2"D x 54" H* | 102"L x 44 1/2"D x 54" H* |
| List \$ | \$18,970 | \$25,650 |

*To top of glass
Dimensions shown are not exact. Refer to Factory Specification drawings for more detail.

| Product Specification | Standard (N/C) | Option(s) | List \$ |
|---|--|---|------------------------------------|
| Interior Color* | Black | White Stainless Steel | N/C \$1,980 |
| Exterior Color* ¹ | Choice of Wilsonart® or Formica® non-premium laminates | Wilsonart® or Formica® premium laminates (as noted in laminate charts) Other manufacturer's laminates Stainless Steel | \$620 Call for quote \$1,250 |
| Front Glass Posts* ³ | Black | Silver | N/C |
| End Panel* | No end panel | Solid end with glass upper Case to case glass end | \$240/end \$100/end |
| Back Panel* | Solid back - White | Black Stainless Steel | N/C \$1,200 |
| Front Panel Style* ⁵ | Straight front | Step front (increased depth of unit 10") | \$600 |
| Interior display, front & rear ledge* ² | Corian® solid surface - Black Night Sky | Solid surface - special colors (may increase lead time) | Call for quote |
| Base* | Levelers | 6"H legs (increases height of case 6") | \$350 |
| Toe Kick* ⁴ | Black | Stainless Steel White | \$250 N/C |
| Refrigeration* | Remote (compressor supplied by others) | Self-contained refrigeration (TBD based on lineup) | Call for quote |
| Miscellaneous (Must be chosen when case is ordered) | | Second year parts & labor warranty | \$530 |

*Must choose one when placing order

| MODEL | WEIGHT | Self-Contained Refrigeration/Dry | | | Remote Refrigeration with Leads | | |
|---------|--------|----------------------------------|------|-----------|---------------------------------|------|-------|
| | | VOLTS | AMPS | NEMA PLUG | VOLTS | AMPS | BTUH |
| RTSIW45 | 1,200 | TBD Based on line up | | | 120/1/60 | .54 | 1,760 |
| RTSIW90 | 1,200 | Contact Factory | | | 120/1/60 | 1.02 | 3,520 |

Freight Class: 110 NOTE: Freight rate subject to linear foot rule.

Based on operating conditions of 75°F and 55% relative humidity. Specifications and pricing subject to change without notice.

Refrigerated Outside Corner Display - Spherical Front Glass

Standard Features

- One refrigerated display level
- No end panels
- Spherical single pane fixed front glass
- Straight laminated front panel
- Integrated average product temperature of 41 °F
- ETL sanitation conforms to NSF 7
- 1 year parts and labor warranty

NOTE: Floor plan required.

NOTE: Front glass and solid surface material shipped loose. Must be installed after case is positioned in place.

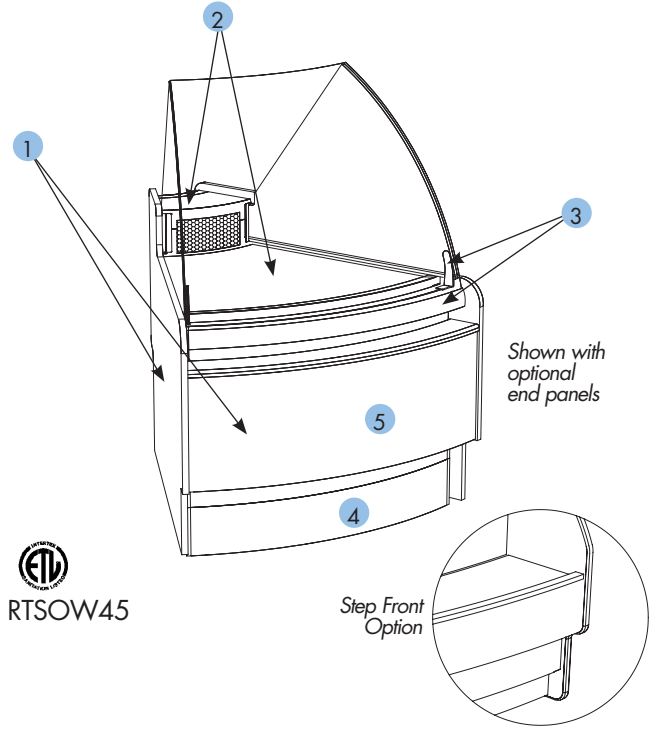

| MODEL | RTSOW45 | RTSOW90 |
|------------|-------------------------|-------------------------|
| Dimensions | 41"L x 44 1/2"D x 54"H* | 75"L x 44 1/2"D x 54"H* |
| List \$ | \$18,970 | \$25,650 |

*To top of glass
Dimensions shown are not exact. Refer to Factory Specification drawings for more detail.

| Product Specification | Standard (N/C) | Option(s) | List \$ |
|---|--|---|------------------------------------|
| Interior Color* | Black | White Stainless Steel | N/C \$1,980 |
| Exterior Color* ¹ | Choice of Wilsonart® or Formica® non-premium laminates | Wilsonart® or Formica® premium laminates (as noted in laminate charts) Other manufacturer's laminates Stainless Steel | \$620 Call for quote \$1,250 |
| Front Glass Posts* ³ | Black | Silver | N/C |
| End Panel* | No end panel | Solid end with glass upper Case to case glass end | \$240/end \$100/end |
| Back Panel* | Solid panel - White | Black Stainless Steel | N/C \$1,200 |
| Front Panel Style* ⁵ | Straight front | Step front (increases depth of unit 10") | \$600 |
| Interior display, front & rear ledge* ² | Corian® solid surface - Black Night Sky | Solid surface - special colors (may increase lead time) | Call for quote |
| Base* | Levelers | 6"H legs (increases height of case 6") | \$350 |
| Toe Kick* ⁴ | Black | Stainless Steel White | \$250 N/C |
| Refrigeration* | Remote (compressor supplied by others) | Self-contained refrigeration (TBD based on lineup) | Call for quote |
| Miscellaneous (Must be chosen when case is ordered) | | Second year parts & labor warranty | \$530 |

*Must choose one when placing order

| MODEL | WEIGHT | Self-Contained Refrigeration/Dry | | | Remote Refrigeration with Leads | | |
|---------|--------|----------------------------------|------|-----------|---------------------------------|------|-------|
| | | VOLTS | AMPS | NEMA PLUG | VOLTS | AMPS | BTUH |
| RTSOW45 | 1,200 | TBD Based on line up | | | 120/1/60 | .54 | 1,444 |
| RTSOW90 | 1,200 | Contact Factory | | | 120/1/60 | .94 | 2,888 |

Freight Class: 110 NOTE: Freight rate subject to linear foot rule.

Based on operating conditions of 75°F and 55% relative humidity. Specifications and pricing subject to change without notice.

Non-Refrigerated Display Table - Curved Front Glass

Standard Features

- One non-refrigerated display level
- Two end panels
- Curved single pane fixed front glass
- Straight laminated front panel
- 1 year parts and labor warranty

NOTE: Floor plan required.

NOTE: Front glass and solid surface material shipped loose.
Must be installed after case is positioned in place.

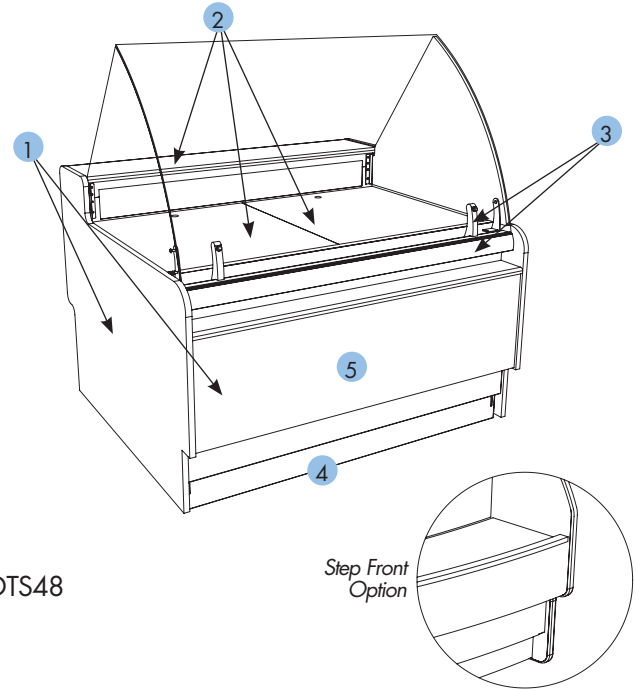

DTS48

Step Front
Option

| MODEL | DTS36 | DTS48 | DTS60 |
|------------|-------------------------|-------------------------|-------------------------|
| Dimensions | 39"L x 44 1/2"D x 54"H* | 51"L x 44 1/2"D x 54"H* | 63"L x 44 1/2"D x 54"H* |
| List \$ | \$14,135 | \$16,115 | \$18,370 |

*To top of glass

Dimensions shown are not exact. Refer to Factory Specification drawings for more detail.

| Product Specification | Standard (N/C) | Option(s) | List \$ |
|--|--|---|------------------------------------|
| Interior Color* | Black | White Stainless Steel | N/C \$1,980 |
| Exterior Color* ¹ | Choice of Wilsonart® or Formica® non-premium laminates | Wilsonart® or Formica® premium laminates (as noted in laminate charts) Other manufacturer's laminates Stainless Steel | \$620 Call for quote \$1,250 |
| Front Glass Posts* ³ | Black | Silver | N/C |
| End Panel* | Solid end with glass upper | Case to case glass end Deduct end panel (for case to case lineups) | -\$100/end -\$240/end |
| Back Panel* | Solid panel - White | Black Stainless Steel | N/C \$1,200 |
| Front Panel Style* ⁵ | Straight front | Step front (increases depth of unit 10") | \$600 |
| Interior display, front & rear ledge* ² | Corian® solid surface - Black Night Sky | Solid surface - special colors (may increase lead time) | Call for quote |
| Base* | Levelers | Casters** 6"H legs (increases height of case 6") | \$340 \$350 |
| Toe Kick* ⁴ | Black | Stainless Steel White | \$250 N/C |
| Miscellaneous (Must be chosen when case is ordered) | | Second year parts & labor warranty | \$530 |

*Must choose one when placing order

**May increase height of case - refer to specification sheet

| MODEL | WEIGHT | Self-Contained Refrigeration/Dry | | |
|-------|--------|----------------------------------|------|-----------|
| | | VOLTS | AMPS | NEMA PLUG |
| DTS36 | 990 | N/A | N/A | N/A |
| DTS48 | 1,000 | N/A | N/A | N/A |
| DTS60 | 1,250 | N/A | N/A | N/A |

Freight Class: 125 NOTE: Freight rate subject to linear foot rule.

Based on operating conditions of 75°F and 55% relative humidity.
Specifications and pricing subject to change without notice.

Non-Refrigerated Inside Corner Display - Spherical Front Glass

Standard Features

- One non-refrigerated display level
- No end panels
- Spherical single pane fixed front glass
- Straight laminated front panel
- 1 year parts and labor warranty

NOTE: Floor plan required.

NOTE: Front glass and solid surface material shipped loose.
Must be installed after case is positioned in place.

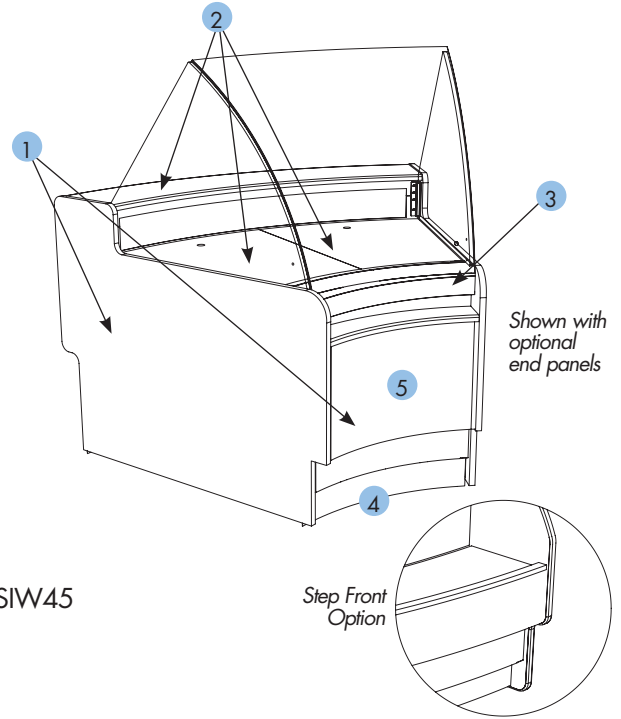

DTSIW45

| MODEL | DTSIW45 | DTSIW90 |
|------------|-------------------------|--------------------------|
| Dimensions | 56"L x 44 1/2"D x 54"H* | 102"L x 44 1/2"D x 54"H* |
| List \$ | \$12,705 | \$15,635 |

*To top of glass

Dimensions shown are not exact. Refer to Factory Specification drawings for more detail.

| Product Specification | Standard (N/C) | Option(s) | List \$ |
|---|--|---|------------------------------------|
| Interior Color* | Black | White Stainless Steel | N/C \$1,980 |
| Exterior Color* ¹ | Choice of Wilsonart® or Formica® non-premium laminates | Wilsonart® or Formica® premium laminates (as noted in laminate charts) Other manufacturer's laminates Stainless Steel | \$620 Call for quote \$1,250 |
| Front Glass Posts* ³ | Black | Silver | N/C |
| End Panel* | No end panel | Solid end with glass upper Case to case glass end | \$240/end \$100/end |
| Back Panel* | Solid panel - White | Black Stainless Steel | N/C \$1,200 |
| Front Panel Style* ⁵ | Straight front | Step front (increases depth of unit 10") | \$600 |
| Interior display, front & rear ledge * ² | Corian® solid surface - Black Night Sky | Solid surface - special colors (may increase lead time) | Call for quote |
| Base* | Levelers | 6"H legs (increases height of case 6") | \$350 |
| Toe Kick * ⁴ | Black | Stainless Steel White | \$250 N/C |
| Miscellaneous (Must be chosen when case is ordered) | | Second year parts & labor warranty | \$530 |

*Must choose one when placing order

| MODEL | WEIGHT | Self-Contained Refrigeration/Dry | | |
|---------|--------|----------------------------------|------|-----------|
| | | VOLTS | AMPS | NEMA PLUG |
| DTSIW45 | 990 | N/A | N/A | N/A |
| DTSIW90 | 1,000 | N/A | N/A | N/A |

Freight Class: 125 NOTE: Freight rate subject to linear foot rule.

Based on operating conditions of 75°F and 55% relative humidity.
Specifications and pricing subject to change without notice.

Non-Refrigerated Outside Corner Display - Spherical Front Glass

Standard Features

- One non-refrigerated display level
- No end panels
- Spherical single pane fixed front glass
- Straight laminated front panel
- 1 year parts and labor warranty

NOTE: Floor plan required.

NOTE: Front glass and solid surface material shipped loose.
Must be installed after case is positioned in place.

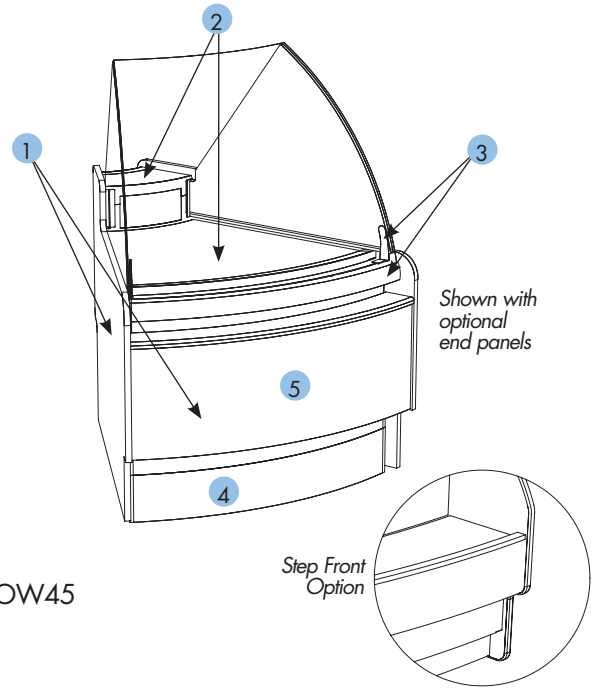

DTSOW45

| MODEL | DTSOW45 | DTSOW90 |
|------------|-------------------------|-------------------------|
| Dimensions | 41"L x 44 1/2"D x 54"H* | 75"L x 44 1/2"D x 54"H* |
| List \$ | \$12,705 | \$15,635 |

*To top of glass

Dimensions shown are not exact. Refer to Factory Specification drawings for more detail.

| Product Specification | Standard (N/C) | Option(s) | List \$ |
|--|--|---|------------------------------------|
| Interior Color* | Black | White Stainless Steel | N/C \$1,980 |
| Exterior Color* ¹ | Choice of Wilsonart® or Formica® non-premium laminates | Wilsonart® or Formica® premium laminates (as noted in laminate charts) Other manufacturer's laminates Stainless Steel | \$620 Call for quote \$1,250 |
| Front Glass Posts* ³ | Black | Silver | N/C |
| End Panel* | No end panel | Solid end with glass upper Case to case glass end | \$240/end \$100/end |
| Back Panel* | Solid panel - White | Black Stainless Steel | N/C \$1,200 |
| Front Panel Style* ⁵ | Straight front | Step front (increases depth of unit 10") | \$600 |
| Interior display, front & rear ledge * ² | Corian® solid surface - Black Night Sky | Solid surface - special colors (may increase lead time) | Call for quote |
| Base* | Levelers | 6"H legs (increases height of case 6") | \$350 |
| Toe Kick * ⁴ | Black | Stainless Steel White | \$250 N/C |
| Miscellaneous (Must be chosen when case is ordered) | | Second year parts & labor warranty | \$530 |

*Must choose one when placing order

| MODEL | WEIGHT | Self-Contained Refrigeration/Dry | | |
|---------|--------|----------------------------------|------|-----------|
| | | VOLTS | AMPS | NEMA PLUG |
| DTSOW45 | 990 | N/A | N/A | N/A |
| DTSOW90 | 1,000 | N/A | N/A | N/A |

Freight Class: 125 NOTE: Freight rate subject to linear foot rule.

Based on operating conditions of 75°F and 55% relative humidity.
Specifications and pricing subject to change without notice.

Non-Refrigerated Pass Through Display

Standard Features

- Non-refrigerated display surface
- No end panels
- Straight laminated front panel
- 1 year parts and labor warranty

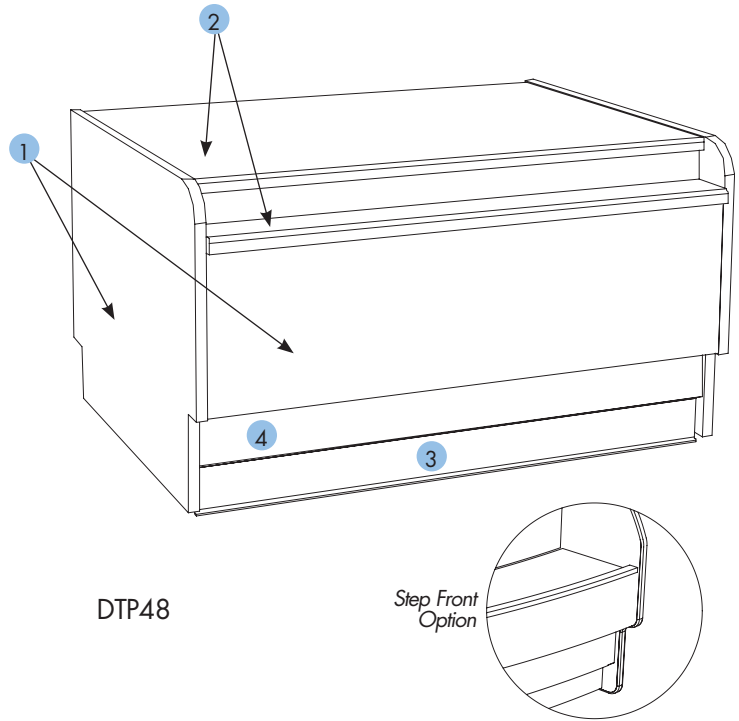

DTP48

Step Front Option

| MODEL | DTP36 | DTP48 |
|------------|----------------------------|----------------------------|
| Dimensions | 39"L x 44 1/2"D x 29 1/2"H | 50"L x 44 1/2"D x 29 1/2"H |
| List \$ | \$12,500 | \$13,995 |

Dimensions shown are not exact. Refer to Factory Specification drawings for more detail.

| Product Specification | Standard (N/C) | Option(s) | List \$ |
|---|--|---|------------------------------------|
| Interior Color* | Black | White Stainless Steel | N/C \$1,980 |
| Exterior Color* ¹ | Choice of Wilsonart® or Formica® non-premium laminates | Wilsonart® or Formica® premium laminates (as noted in laminate charts) Other manufacturer's laminates Stainless Steel | \$620 Call for quote \$1,250 |
| End Panel* | No end panel | Solid end | \$240/end |
| Back Panel* | Solid panel - White | Black Stainless Steel | N/C \$1,200 |
| Front Panel Style * ⁴ | Straight front | Step front (increases depth of unit 10") | \$600 |
| Interior display, front & rear ledge * ² | Corian® solid surface - Black Night Sky | Solid surface - special colors (may increase lead time) | Call for quote |
| Base* | Levelers | Casters ** 6"H legs (increases height of case 6") | \$340 \$350 |
| Toe Kick* ³ | Black | Stainless Steel White | \$250 N/C |
| Miscellaneous (Must be chosen when case is ordered) | | Second year parts & labor warranty | \$530 |

*Must choose one when placing order

**May increase height of case - refer to specification sheet

| MODEL | WEIGHT |
|-------|--------|
| DTP36 | 990 |
| DTP48 | 1,000 |

Freight Class: 125 NOTE: Freight rate subject to linear foot rule.

Based on operating conditions of 75°F and 55% relative humidity. Specifications and pricing subject to change without notice.

Refrigerated Service Gelato Case

Standard Features

- Breeze™ Refrigeration System (See page 1)
- Two T-8 top lights
- Curved single pane lift-up front glass
- Two rows of sign channel in front of pans
- Painted exterior (specify color)
- Stainless Steel:
 - Interior
 - Lower front panel
 - Rear ledge
- Levelers
- Foam-in-place insulated tub fully accessible for refrigeration service and cleaning
- 6' power cord
- Integrated average product temperature of -2°F
- ETL sanitation conforms to NSF 7
- ETL Listed Certified to CAN/CSA 22.2
- 1 year parts and labor; 5 year compressor warranty

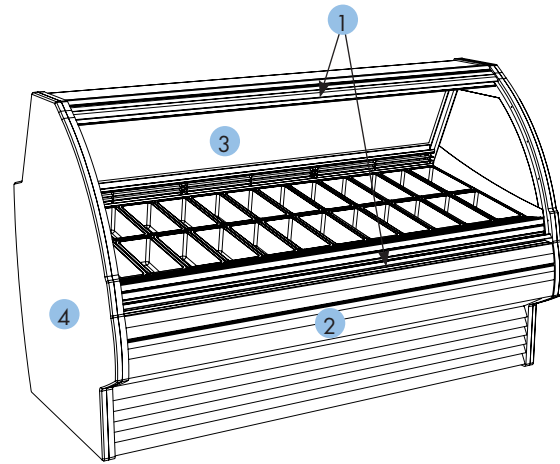

G24F

NOTE: Compressor air intake from rear and out front panel at toe kick. Toe kick cannot be blocked.

| MODEL | G24F |
|------------|----------------------------------|
| Dimensions | 84 1/2" L x 43 3/8" D x 53 3/4"H |
| List \$ | \$34,138 |

Dimensions shown are not exact. Refer to Factory Specification drawings for more detail.

| Product Specification | Standard (N/C) | Option(s) | List \$ |
|--|---|--|---------------------------------|
| Trim Color* ¹ | Black | Silver | N/C |
| Upper Front Panel* ² | Black | Silver Painted (specify color) | N/C N/C |
| Upper Rear* ³ | Open | Clear glass sliding doors w/o lock | \$1,050 |
| End Panel* ⁴ | Full with mirror | Cutaway with glass | \$1,040/end |
| Refrigeration* | Breeze™ self-contained with rear intake/front air discharge at toe kick (floor drain required) | Breeze™ self-contained system with evaporator pan Remote (compressor supplied by others) Pressure release valve (required for city of Chicago) must be ordered with case | \$460 Call for quote \$50 |
| Pans* | Gelato Stainless Steel 5-liter (24 pans) | Stainless Steel one-third size foodservice pans (22 pans) | N/C |
| Miscellaneous (Must be chosen when case is ordered) | | Night curtain, pull-down, non-locking Second year parts & labor warranty (excludes compressor) | \$420 \$530 |
| Accessories (Can be purchased at any time. Refer to pages 76/77 for information) | | Dipwell 10" Extra set of pans - Gelato Stainless Steel 5-liter pans (24) Extra set of pans - Stainless Steel one-third size foodservice pans (22) | \$400 \$2,100 \$650 |

*Must choose one when placing order

| MODEL | WEIGHT | Self-Contained Refrigeration/Dry | | | Remote Refrigeration with Leads | | |
|-------|--------|----------------------------------|-------|-----------|---------------------------------|------|-------|
| | | VOLTS | AMPS | NEMA PLUG | VOLTS | AMPS | BTUH |
| G24F | 1,550 | 220/1/60* | 25.91 | 14-30P | 220/1/60 | 1.66 | 4,700 |

Freight Class: 110

NOTE: Freight rate subject to linear foot rule.

*Requires three wires plus ground

Based on operating conditions of 75°F and 55% relative humidity. Specifications and pricing subject to change without notice.

Refrigerated Self-Service Case - 51"H

Standard Features

- Breeze™ Refrigeration System (See page 1)
- Three adjustable/removable clear glass shelves (16"D, 20"D, 24"D)
- Two full end panels with mirror interior
- Solid back panel
- Bottom sheet metal deck
- Open reach-in front (unit filled & customer selection from front)
- T-8 top light and shelf lights
- 6' power cord
- Integrated average product temperature of 41°F
- ETL sanitation conforms to NSF 7
- ETL Listed Certified to CAN/CSA 22.2
- 1 year parts and labor; 5 year compressor warranty

NOTE: Compressor air intake from rear and out front panel at toe kick.
Toe kick cannot be blocked.

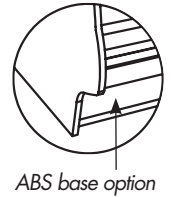
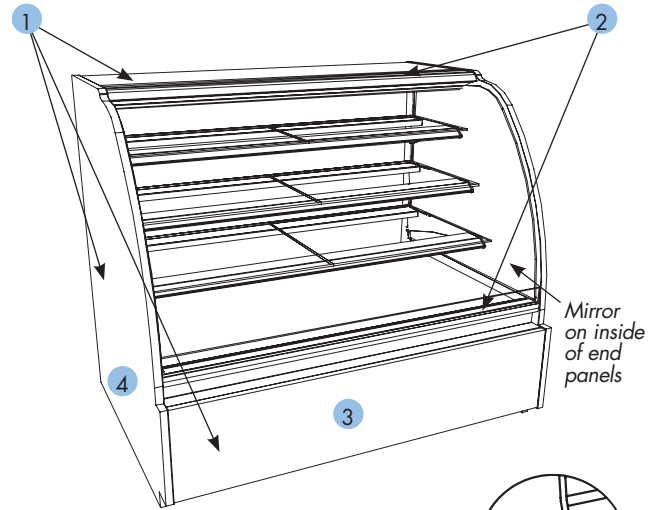

| MODEL | HV38RSS | HV48RSS | HV56RSS | HV74RSS |
|------------|--------------------|--------------------|--------------------|--------------------|
| Dimensions | 40"L x 42"D x 51"H | 50"L x 42"D x 51"H | 58"L x 42"D x 51"H | 76"L x 42"D x 51"H |
| List \$ | \$12,353 | \$13,147 | \$14,007 | \$15,683 |

Dimensions shown are not exact. Refer to Factory Specification drawings for more detail.

| Product Specification | Standard (N/C) | Option(s) | List \$ |
|--|---|--|---|
| Interior Color* | Black | White Stainless Steel | N/C \$1,980 |
| Exterior Color* ¹ | Choice of Wilsonart® or Formica® non-premium laminates | Wilsonart® or Formica® premium laminates (as noted in laminate charts) Other manufacturer's laminates Painted (applies only with ABS angled front panel) (specify color) Stainless Steel (straight front panel required) Oak veneer with clear sealer (straight front panel required) Oak veneer stained (straight front panel required) (color match required) | \$620 Call for quote N/C \$1,250 \$1,700 \$1,930 |
| Trim Color* ² | Black | Silver Gold | N/C \$260 |
| Front Panel Style* ³ | Straight front (laminated) | ABS upper front with angled lower (painted) (case is 3/4" less deep) | N/C |
| End Panel Style* ⁴ | Full with mirror | Cutaway with glass Case to case glass end Deduct end panel (for case to case lineups) | \$590/end -\$100/end -\$240/end |
| Base* | Levelers | Casters (not available with remote refrigeration)** | \$340 |
| Refrigeration* | Breeze™ self-contained w/ evaporator pan (rear air intake/ front air discharge at toe kick) | Remote (compressor supplied by others) Pressure release valve (required for city of Chicago) must be ordered with case | Call for quote \$50 |
| Miscellaneous (Must be chosen when case is ordered) | | Second year parts & labor warranty (excludes compressor) | \$530 |
| Accessories (Can be purchased at any time. Refer to pages 76/77 for information) | | Removable wire security cover, locking Night curtain, pull-down, non-locking | \$910 \$420 |

*Must choose one when placing order

**May increase height of case - refer to specification sheet

| MODEL | WEIGHT | Self-Contained Refrigeration/Dry | | | Remote Refrigeration with Leads | | |
|---------|--------|----------------------------------|-------|-----------|---------------------------------|------|-------|
| | | VOLTS | AMPS | NEMA PLUG | VOLTS | AMPS | BTUH |
| HV38RSS | 780 | 120/1/60 | 15.48 | 5-20P | 120/1/60 | 2.16 | 4,226 |
| HV48RSS | 930 | 220/1/60* | 12.77 | 14-20P | 120/1/60 | 2.27 | 5,350 |
| HV56RSS | 930 | 220/1/60* | 12.83 | 14-20P | 120/1/60 | 2.33 | 6,143 |
| HV74RSS | 1,180 | 220/1/60* | 17.35 | 14-20P | 120/1/60 | 3.86 | 8,010 |

Freight Class: 110 NOTE: Freight rate subject to linear foot rule. *Requires three wires plus ground

Based on operating conditions of 75°F and 55% relative humidity. Note: Product temperatures will be affected if the air curtain is disrupted. Specifications and pricing subject to change without notice.

Refrigerated Self-Service Case - 51" H with Rear Doors

Standard Features

- Breeze™ Refrigeration System (See page 1)
- Three adjustable/removable clear glass shelves (16"D, 20"D, 24"D)
- Two full end panels with mirror interior
- Clear glass rear sliding doors with inner plexi plenum
- Open reach-in front
- Bottom sheet metal deck
- T-8 top light and shelf lights
- 6' power cord
- Integrated average product temperature of 41°F
- ETL sanitation conforms to NSF 7
- ETL Listed Certified to CAN/CSA 22.2
- 1 year parts and labor; 5 year compressor warranty

NOTE: Compressor air intake from rear and out front panel at toe kick. Toe kick cannot be blocked.

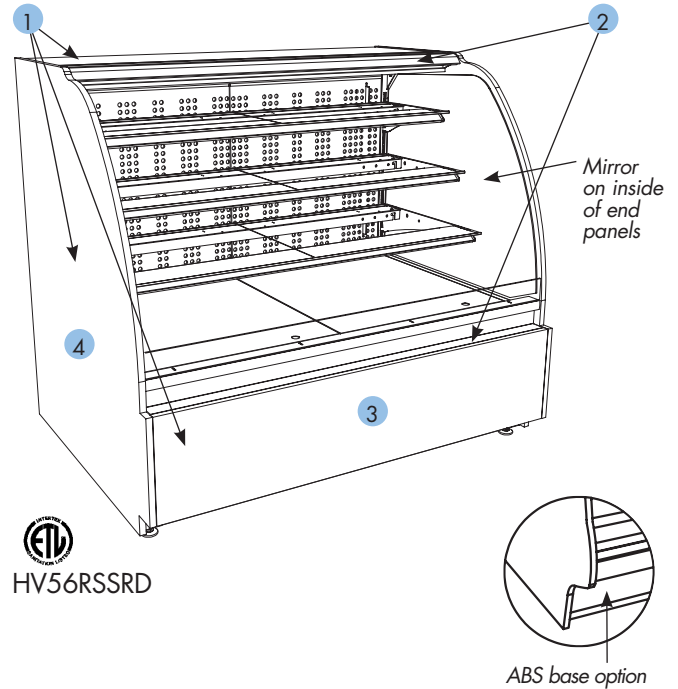

| MODEL | HV38RSSRD | HV48RSSRD | HV56RSSRD | HV74RSSRD |
|------------|--------------------|--------------------|--------------------|--------------------|
| Dimensions | 40"L x 42"D x 51"H | 50"L x 42"D x 51"H | 58"L x 42"D x 51"H | 76"L x 42"D x 51"H |
| List \$ | \$13,645 | \$14,439 | \$15,299 | \$16,975 |

Dimensions shown are not exact. Refer to Factory Specification drawings for more detail.

| Product Specification | Standard (N/C) | Option(s) | List \$ |
|--|--|--|---|
| Interior Color* | Black | White Stainless Steel | N/C \$1,980 |
| Exterior Color* ¹ | Choice of Wilsonart® or Formica® non-premium laminates | Wilsonart® or Formica® premium laminates (as noted in laminate charts) Other manufacturer's laminates Painted (applies only with ABS angled front panel) (specify color) Stainless Steel (straight front panel required) Oak veneer with clear sealer (straight front panel required) Oak veneer stained (straight front panel required) (color match required) | \$620 Call for quote N/C \$1,250 \$1,700 \$1,930 |
| Trim Color* ² | Black | Silver Gold | N/C \$260 |
| Front Panel Style* ³ | Straight front (laminated) | ABS upper front with angled lower (painted) (case is 3/4" less deep) | N/C |
| End Panel Style* ⁴ | Full with mirror | Cutaway with glass Case to case glass end Deduct end panel (for case to case lineups) | \$590/end -\$100/end -\$240/end |
| Base* | Levelers | Castors (not available with remote refrigeration)** | \$340 |
| Refrigeration* | Breeze™ self-contained w/ evaporator pan | Remote (compressor supplied by others) Pressure release valve (required for city of Chicago) must be ordered with case | Call for quote \$50 |
| Miscellaneous (Must be chosen when case is ordered) | | Second year parts & labor warranty (excludes compressor) | \$530 |
| Accessories (Can be purchased at any time. Refer to pages 76/77 for information) | | Removable wire security cover, locking Night curtain, pull-down, non-locking | \$910 \$420 |

*Must choose one when placing order

**May increase height of case - refer to specification sheet

| MODEL | WEIGHT | Self-Contained Refrigeration/Dry | | | Remote Refrigeration with Leads | | |
|-----------|--------|----------------------------------|-------|-----------|---------------------------------|------|-------|
| | | VOLTS | AMPS | NEMA PLUG | VOLTS | AMPS | BTUH |
| HV38RSSRD | 780 | 120/1/60 | 16.38 | 5-20P | 120/1/60 | 2.54 | 4,226 |
| HV48RSSRD | 900 | 220/1/60* | 17.71 | 14-20P | 120/1/60 | 2.33 | 5,350 |
| HV56RSSRD | 950 | 220/1/60* | 14.8 | 14-20P | 120/1/60 | 2.33 | 6,143 |
| HV74RSSRD | 1,100 | 220/1/60* | 18.49 | 14-30P | 120/1/60 | 3.86 | 8,010 |

Freight Class: 110 NOTE: Freight rate subject to linear foot rule. *Requires three wires plus ground

Based on operating conditions of 75°F and 55% relative humidity. Specifications and pricing subject to change without notice.

Note: Product temperatures will be affected if the air curtain is disrupted.

Refrigerated Self-Service Case - 37"H

Standard Features

- Breeze™ Refrigeration System (See page 1)
- One adjustable/removable clear glass shelf (16"D)
- Two full end panels with mirror interior
- Solid back panel
- Bottom sheet metal deck
- Open reach-in front (unit filled & customer selection from front)
- T-8 top light and shelf lights
- 6' power cord
- Integrated average product temperature of 41°F
- ETL sanitation conforms to NSF 7
- ETL Listed Certified to CAN/CSA 22.2
- 1 year parts and labor; 5 year compressor warranty

NOTE: Compressor air intake from rear and out front panel at toe kick.
Toe kick cannot be blocked.

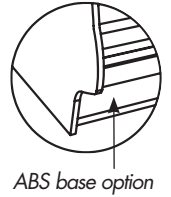
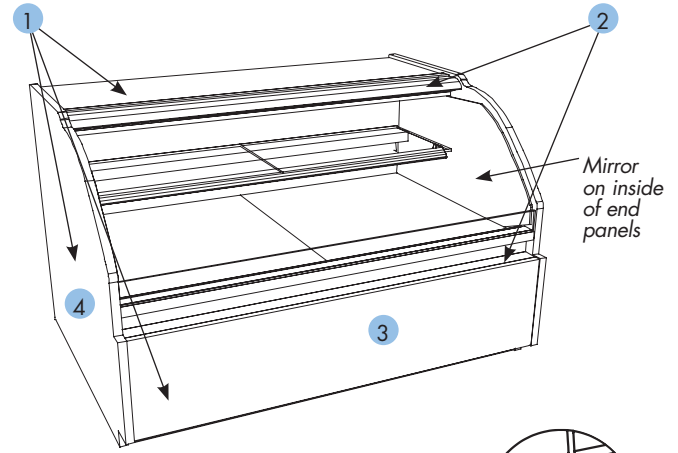

| MODEL | HV3638RSS | HV3648RSS | HV3656RSS | HV3674RSS |
|------------|--------------------|--------------------|--------------------|--------------------|
| Dimensions | 40"L x 42"D x 37"H | 50"L x 42"D x 37"H | 58"L x 42"D x 37"H | 76"L x 42"D x 37"H |
| List \$ | \$11,703 | \$12,454 | \$13,270 | \$14,905 |

Dimensions shown are not exact. Refer to Factory Specification drawings for more detail.

| Product Specification | Standard (N/C) | Option(s) | List \$ |
|--|---|--|---|
| Interior Color* ¹ | Black | White Stainless Steel | N/C \$1,980 |
| Exterior Color* ¹ | Choice of Wilsonart® or Formica® non-premium laminates | Wilsonart® or Formica® premium laminates (as noted in laminate charts) Other manufacturer's laminates Painted (applies only with ABS angled front panel) (specify color) Stainless Steel (straight front panel required) Oak veneer with clear sealer (straight front panel required) Oak veneer stained (straight front panel required) (color match required) | \$620 Call for quote N/C \$1,250 \$1,700 \$1,930 |
| Trim Color* ² | Black | Silver Gold | N/C \$260 |
| Front Panel Style* ³ | Straight front (laminated) | ABS upper front with angled lower (painted) (case is 3/4" less deep) | N/C |
| End Panel Style* ⁴ | Full with mirror | Case to case glass end Deduct end panel (for case to case lineups) | -\$100/end -\$240/end |
| Base* | Levelers | Casters (not available with remote refrigeration) ** | \$340 |
| Refrigeration* | Breeze™ self-contained w/ evaporator pan (rear air intake/ front air discharge at toe kick) | Remote (compressor supplied by others) Pressure release valve (required for city of Chicago) must be ordered with case | Call for quote \$50 |
| Miscellaneous (Must be chosen when case is ordered) | | Second year parts & labor warranty (excludes compressor) | \$530 |
| Accessories (Can be purchased at any time. Refer to pages 76/77 for information) | | Removable wire security cover, locking Night curtain, pull-down, non-locking | \$910 \$420 |

*Must choose one when placing order

**May increase height of case - refer to specification sheet

| MODEL | WEIGHT | Self-Contained Refrigeration/Dry | | | Remote Refrigeration with Leads | | |
|-----------|--------|----------------------------------|-------|-----------|---------------------------------|------|-------|
| | | VOLTS | AMPS | NEMA PLUG | VOLTS | AMPS | BTUH |
| HV3638RSS | 610 | 120/1/60 | 11.92 | 5-15P | 120/1/60 | 1.76 | 2,763 |
| HV3648RSS | 700 | 120/1/60 | 17.39 | 5-20P | 120/1/60 | 1.53 | 3,562 |
| HV3656RSS | 750 | 120/1/60 | 20.67 | 5-30P | 120/1/60 | 2.27 | 4,260 |
| HV3674RSS | 1,000 | 220/1/60* | 16.8 | 14-20P | 120/1/60 | 2.8 | 5,630 |

Freight Class: 110

NOTE: Freight rate subject to linear foot rule.

*Requires three wires plus ground

Based on operating conditions of 75°F and 55% relative humidity. Specifications and pricing subject to change without notice.

Note: Product temperatures will be affected if the air curtain is disrupted.

Non-Refrigerated Pull-Out Drawer Case

Standard Features

- Stay-open pull-out drawers with wire baskets (18"x22"x4")
 - HVB38SS - 6 drawers
 - HVB56SS - 9 drawers
 - HVB74SS - 12 drawers
- Two full end panels (no mirror inside)
- T-8 top light and shelf lights
- Recessed front storage for packaging supplies
- 12" power cord
- ETL sanitation conforms to NSF 2
- ETL Listed Certified to CAN/CSA 22.2
- 1 year parts and labor warranty

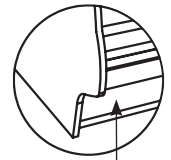
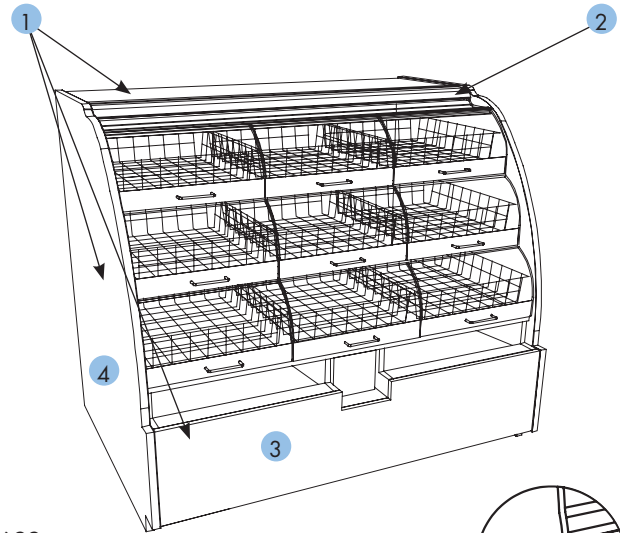

ABS base option

| MODEL | HVB38SS | HVB56SS | HVB74SS |
|------------|--------------------|--------------------|--------------------|
| Dimensions | 39"L x 41"D x 51"H | 58"L x 41"D x 51"H | 76"L x 41"D x 51"H |
| List \$ | \$13,531 | \$15,677 | \$18,653 |

Dimensions shown are not exact. Refer to Factory Specification drawings for more detail.

| Product Specification | Standard (N/C) | Option(s) | List \$ |
|---|--|--|--------------------------------|
| Interior Color* | Black | White | N/C |
| Exterior Color* ¹ | Choice of Wilsonart® or Formica® non-premium laminates | Wilsonart® or Formica® premium laminates (as noted in laminate charts) Other manufacturer's laminates Painted (applies only with ABS angled front panel) (specify color) | \$620 Call for quote N/C |
| Trim Color* ² | Black | Silver Gold | N/C \$260 |
| Upper Rear* | Open (No doors) | Solid back panel, white Clear or reflective glass sliding doors | \$320 \$260 |
| Front Panel Style* ³ | Straight front (laminated) | ABS upper front with angled lower (painted) (case is 3/4" less deep) | N/C |
| End Panel Style* ⁴ | Full (no mirror) | Deduct end panel (for case to case lineups)** | -\$240/end |
| Base* | Levelers | Casters** | \$340 |
| Miscellaneous (Must be chosen when case is ordered) | | Second year parts & labor warranty | \$530 |
| Accessories (Can be purchased at any time. Refer to pages 76/77 for information) | | Wire baskets, 1 1/2"H (Chrome or Black) Basket liners (1 1/2"H or 4"H) Tongs (inside of basket) | \$125 \$500 \$375 |

*Must choose one when placing order

**May increase height of case - refer to specification sheet

***The HVB models can only be joined without end panels to other HVB models

| MODEL | WEIGHT | Self-Contained Refrigeration/Dry | | |
|---------|--------|----------------------------------|------|-----------|
| | | VOLTS | AMPS | NEMA PLUG |
| HVB38SS | 650 | 120/1/60 | 1.06 | 5-15P |
| HVB56SS | 950 | 120/1/60 | 1.06 | 5-15P |
| HVB74SS | 1,050 | 120/1/60 | 2.12 | 5-15P |

Freight Class: 125

NOTE: Freight rate subject to linear foot rule.

Based on operating conditions of 75°F and 55% relative humidity.
Specifications and pricing subject to change without notice.

Non-Refrigerated Acrylic Door Case

Standard Features

- Two adjustable/removable wire rack shelves (20"D, 26"D)
- Clear acrylic lift-up free fall front doors
 - HVAD48SS/HVAD56SS - 6 doors
 - HVAD74SS - 9 doors
- Two full end panels with mirror interior
- Tray capacity
 - HVAD48SS - (6) 18"x26" trays (not supplied with unit)
 - HVAD56SS - (9) 18"x26" trays (not supplied with unit)
 - HVAD74SS - (12) 18"x26" trays (not supplied with unit)
- T-8 top light and shelf lights
- Recessed front storage for packaging supplies
- 12" power cord
- ETL sanitation conforms to NSF 2
- ETL Listed Certified to CAN/CSA 22.2
- 1 year parts and labor warranty

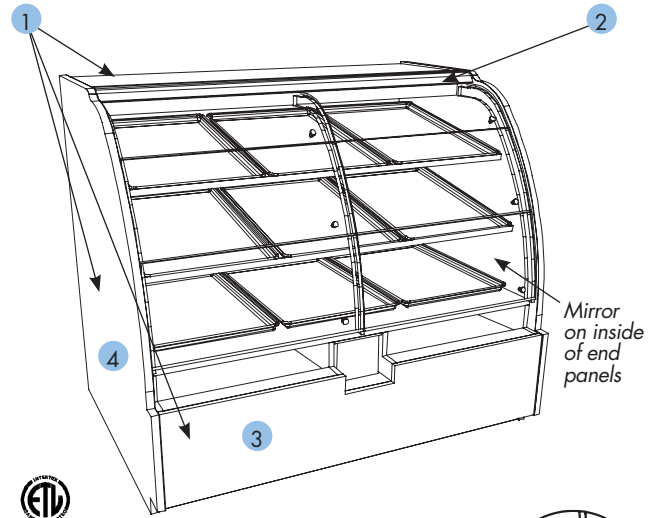

NOTE: Trays not supplied with unit.

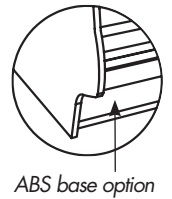

| MODEL | HVAD48SS | HVAD56SS | HVAD74SS |
|------------|--------------------|--------------------|--------------------|
| Dimensions | 50"L x 41"D x 51"H | 58"L x 41"D x 51"H | 76"L x 41"D x 51"H |
| List \$ | \$11,175 | \$11,962 | \$13,346 |

Dimensions shown are not exact. Refer to Factory Specification drawings for more detail.

| Product Specification | Standard (N/C) | Option(s) | List \$ |
|--|--|---|--|
| Interior Color* | Black | White | N/C |
| Exterior Color* ¹ | Choice of Wilsonart® or Formica® non-premium laminates | Wilsonart® or Formica® premium laminates (as noted in laminate charts) Other manufacturer's laminates Painted (applies only with ABS angled front panel) (specify color) Oak veneer with clear sealer (straight front panel required) Oak veneer stained (straight front panel required) (color match required) | \$620 Call for quote N/C \$1,700 \$1,930 |
| Trim Color* ² | Black | Silver Gold | N/C \$260 |
| Upper Rear* | Clear glass sliding doors | Reflective glass sliding doors Solid back panel, white | \$260 \$320 |
| Front Panel Style* ³ | Straight front (laminated) | ABS upper front with angled lower (painted) (case is 3/4" less deep) | N/C |
| End Panel Style* ⁴ | Full with mirror | Deduct end panel (for case to case lineups)*** | -\$240/end |
| Base* | Levelers | Casters** | \$340 |
| Miscellaneous (Must be chosen when case is ordered) | | Second year parts & labor warranty | \$530 |

*Must choose one when placing order

**May increase height of case - refer to specification sheet

***The HVAD models can only be joined without end panels to other HVAD models

| MODEL | WEIGHT | Self-Contained Refrigeration/Dry | | |
|----------|--------|----------------------------------|------|-----------|
| | | VOLTS | AMPS | NEMA PLUG |
| HVAD48SS | 700 | 120/1/60 | 1.06 | 5-15P |
| HVAD56SS | 800 | 120/1/60 | 1.06 | 5-15P |
| HVAD74SS | 850 | 120/1/60 | 1.37 | 5-15P |

Freight Class: 125 NOTE: Freight rate subject to linear foot rule.

Based on operating conditions of 75°F and 55% relative humidity.
Specifications and pricing subject to change without notice.

34"D Combination Convertible Service Above Refrigerated Self-Service Case

Standard Features

- Breeze™ Refrigeration System (See page 1)
- Upper service display area
 - Baffle system converts display from refrigerated to non-refrigerated
 - One rear swinging door (HMBC2)
 - Clear glass rear sliding doors (HMBC3 - HMBC6)
 - Clear glass lighted shelf
 - Curved double pane lift-up front glass
- Lower refrigerated self-service display area
 - Single sheet metal deck
- Two cutaway end panels
- Straight front panel
- T-8 top light and shelf lights
- 6' power cord
- Integrated average product temperature of 41°F
- 1 year parts and labor; 5 year compressor warranty

NOTE: Compressor air intake from rear and out front panel at toe kick. Front panel cannot be blocked.

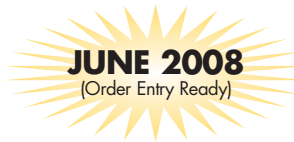

HMBC4

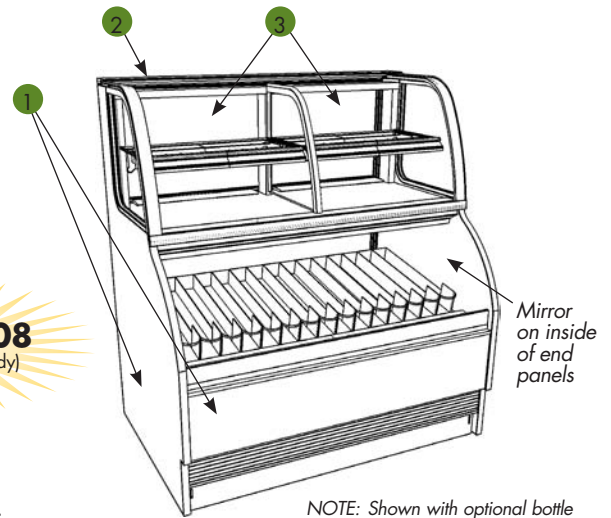

NOTE: Shown with optional bottle slide in lower display

NOTE: Non-divided upper display area - HMBC2 & HMBC3. Divided upper display area - HMBC4, HMBC5, HMBC6.

This model may require additional lead time

| MODEL | HMBC2 | HMBC3 | HMBC4 | HMBC5 | HMBC6 |
|------------|------------------------|------------------------|------------------------|------------------------|------------------------|
| Dimensions | 26 3/4"L x 34"D x 56"H | 38 3/4"L x 34"D x 56"H | 50 3/4"L x 34"D x 56"H | 62 1/2"L x 34"D x 56"H | 75 1/8"L x 34"D x 56"H |
| List \$ | \$14,567 | \$15,143 | \$16,143 | \$17,311 | \$18,709 |

Dimensions shown are not exact. Refer to Factory Specification drawings for more detail.

| Product Specification | Standard (N/C) | Option(s) | List \$ |
|--|---|--|--|
| Interior color* | Black | White Stainless Steel | N/C \$1,980 |
| Exterior Color* ¹ | Choice of Wilsonart® or Formica® non-premium laminates | Wilsonart® or Formica® premium laminates (as noted in laminate charts) Stainless Steel | \$620 \$1,250 |
| Trim Color* ² | Black | Silver | N/C |
| Upper Rear* ³ | Clear glass sliding doors (Swinging door HMBC2) | Reflective glass sliding door | \$260 |
| Lower Rear* | Solid back panel, white | Rear sliding doors (HMBC2 swinging door) | \$1360 |
| Base* | Levelers | Casters (not available with remote refrigeration)** 6"H legs (increases height of case 6") | \$340 \$350 |
| Refrigeration* | Breeze™ self-contained w/ evaporator pan (rear air intake/ front air discharge at toe kick) | Remote (compressor supplied by others) Pressure release valve (required for city of Chicago) must be ordered with case | Call for quote \$50 |
| Miscellaneous (Must be chosen when case is ordered) | | Upper rear door lock Lower rear door lock Clean Sweep® automatic condenser coil cleaner Second year extended parts and labor warranty (excludes compressor) | \$210 \$210 \$990 \$530 |
| Accessories (Can be purchased at any time. Refer to pages 76/77 for information) | | Price tag molding Rear wrapping board Display step for lower display (2" or 4"H) (in lieu of shelf) Clear glass lighted shelf for lower display Bottle slide for lower display Night curtain, pull-down, non-locking Removable wire security cover, locking Angled sheet metal deck | \$130 \$450 \$550 \$480 \$500 \$420 \$500 \$230 |

*Must choose one when placing order

**May increase height of case - refer to specification sheet

| MODEL | WEIGHT | Self-Contained Refrigeration/Dry | | | Remote Refrigeration with Leads | | |
|-------|--------|--|------|-----------|---------------------------------|------|------|
| | | VOLTS | AMPS | NEMA PLUG | VOLTS | AMPS | BTUH |
| HMBC2 | 800 | | | | | | |
| HMBC3 | 850 | | | | | | |
| HMBC4 | 880 | Contact factory for technical electrical information. | | | | | |
| HMBC5 | 900 | | | | | | |
| HMBC6 | 1,150 | | | | | | |

Freight Class: 110 NOTE: Freight rate subject to linear foot rule. Based on operating conditions above 75°F and 55% relative humidity. Specifications and pricing subject to change without notice.

32"D Refrigerated Service Case

Standard Features

- Breeze™ Refrigeration System (See page 1)
- Three adjustable/removable clear glass shelves (13"D, 16"D, 19"D)
- One rear swinging door (HMG2653R)
- Clear glass rear sliding doors (HMG3953R - HMG7553R)
- Curved double pane lift-up front glass
- T-8 top light and shelf lights
- Straight front panel
- 6' power cord
- Integrated average product temperature of 41°F
- ETL sanitation conforms to NSF 7
- ETL Listed Certified to CAN/CSA 22.2
- 1 year parts and labor; 5 year compressor warranty

NOTE: Compressor air intake from rear and out front panel at toe kick. Front panel cannot be blocked.



NOTE: Shown with cutaway with glass end panels

Quick-Ship
See page 10

This model may require additional lead time

| MODEL | HMG2653R | HMG3953R | HMG5153R | HMG6353R | HMG7553R |
|------------|------------------------|--------------------|--------------------|--------------------|--------------------|
| Dimensions | 27"L x 34-3/4"D x 53"H | 39"L x 32"D x 53"H | 51"L x 32"D x 53"H | 63"L x 32"D x 53"H | 75"L x 32"D x 53"H |
| List \$ | \$13,822 | \$14,604 | \$15,402 | \$16,131 | \$16,725 |

Dimensions shown are not exact. Refer to Factory Specification drawings for more detail.

| Product Specification | Standard (N/C) | Option(s) | List \$ |
|--|---|--|--|
| Interior color* | Black | White Stainless Steel | N/C \$1,980 |
| Exterior Color* ¹ | Choice of Wilsonart® or Formica® non-premium laminates | Wilsonart® or Formica® premium laminates (as noted in laminate charts) Other manufacturer's laminates Stainless Steel Oak veneer with clear sealer Oak veneer stained (color match required) | \$620 Call for quote \$1,250 \$1,700 \$1,930 |
| Trim Color* ² | Black | Silver | N/C |
| Upper Rear* | Clear glass sliding doors (Swinging LH hinge door - HMG2653R) | Reflective glass sliding doors Clear glass swinging RH hinge door - HMG2653R | \$260 N/C |
| End Panel Style* ³ | Full with mirror | Cutaway with glass - cannot be joined | \$590/end |
| Base* | Levelers | Casters (not available with remote refrigeration) ** 6"H legs (increases height of case 6") | \$340 \$350 |
| Refrigeration* | Breeze™ self-contained w/ evaporator pan (rear air intake/ front air discharge at toe kick) | Remote (compressor supplied by others) Pressure release valve (required for city of Chicago) must be ordered with case | Call for quote \$50 |
| Miscellaneous (Must be chosen when case is ordered) | | Rear door lock Front glass lock Clean Sweep® automatic condenser coil cleaner Second year parts and labor warranty (excludes compressor) | \$210 \$210 \$990 \$530 |
| Accessories (Can be purchased at any time. Refer to pages 76/77 for information) | | Price tag molding | \$130 |

*Must choose one when placing order

**May increase height of case - refer to specification sheet

| MODEL | WEIGHT | Self-Contained Refrigeration/Dry | | | Remote Refrigeration with Leads | | |
|----------|--------|--|------|-----------|---------------------------------|------|------|
| | | VOLTS | AMPS | NEMA PLUG | VOLTS | AMPS | BTUH |
| HMG2653R | 500 | | | | | | |
| HMG3953R | 900 | | | | | | |
| HMG5153R | 900 | Contact factory for technical electrical information. | | | | | |
| HMG6353R | 1,150 | | | | | | |
| HMG7553R | 1,150 | | | | | | |

Freight Class: 110 NOTE: Freight rate subject to linear foot rule.
Based on operating conditions above 75°F and 55% relative humidity.
Specifications and pricing subject to change without notice.

32"D Non-Refrigerated Service Bakery

Standard Features

- Two full end panels with mirror interior
- Curved single pane lift-up front glass
- One rear swinging door (HMG2653)
- Clear glass sliding doors (HMG3953 - HMG7553)
- Three wire shelves (13"D, 16"D, 16"D)
- T-8 top light and shelf lights
- 12" power cord
- ETL sanitation conforms to NSF 2
- ETL Listed Certified to CAN/CSA 22.2
- 1 year parts and labor warranty



NOTE: Shown with cutaway with glass end panels

This model may require additional lead time

| MODEL | HMG2653 | HMG3953 | HMG5153 | HMG6353 | HMG7553 |
|------------|--------------------|--------------------|--------------------|--------------------|--------------------|
| Dimensions | 27"L x 32"D x 53"H | 39"L x 32"D x 53"H | 51"L x 32"D x 53"H | 63"L x 32"D x 53"H | 75"L x 32"D x 53"H |
| List \$ | \$8,897 | \$9,605 | \$9,692 | \$9,906 | \$11,075 |

Dimensions shown are not exact. Refer to Factory Specification drawings for more detail.

| Product Specification | Standard (N/C) | Option(s) | List \$ |
|--|--|--|--|
| Interior color* | Black | White Stainless Steel | N/C \$1,980 |
| Exterior Color* ¹ | Choice of Wilsonart® or Formica® non-premium laminates | Wilsonart® or Formica® premium laminates (as noted in laminate charts) Other manufacturer's laminates Stainless Steel Oak veneer with clear sealer Oak veneer stained (color match required) | \$620 Call for quote \$1,250 \$1,700 \$1,930 |
| Trim Color* ² | Black | Silver | N/C |
| Upper Rear* | Clear glass sliding doors (Swinging LH hinge door - HMG2653) | Reflective glass sliding doors Clear glass swinging RH hinge door - HMG2653 | \$260 N/C |
| End Panel Style* ³ | Full with mirror | Cutaway with glass - cannot be joined | \$590/end |
| Base* | Levelers | Casters** 6"H legs (increases height of case 6") | \$340 \$350 |
| Shelving* | Wire shelves | Clear glass shelves Smoked glass shelves | \$300 \$300 |
| Miscellaneous (Must be chosen when case is ordered) | | Rear door lock Front glass lock Second year parts and labor warranty | \$210 \$210 \$530 |
| Accessories (Can be purchased at any time. Refer to pages 76/77 for information) | | Price tag molding | \$130 |

*Must choose one when placing order

**May increase height of case - refer to specification sheet

| MODEL | WEIGHT | Self-Contained Refrigeration/Dry | | |
|---------|--------|----------------------------------|------|-----------|
| | | VOLTS | AMPS | NEMA PLUG |
| HMG2653 | 400 | 120/1/60 | 1.22 | 5-15P |
| HMG3953 | 700 | 120/1/60 | .94 | 5-15P |
| HMG5153 | 800 | 120/1/60 | .94 | 5-15P |
| HMG6353 | 950 | 120/1/60 | 1.6 | 5-15P |
| HMG7553 | 1150 | 120/1/60 | 1.6 | 5-15P |

Freight Class: 110 NOTE: Freight rate subject to linear foot rule.

Based on operating conditions above 75°F and 55% relative humidity. Specifications and pricing subject to change without notice.

Refrigerated Service Case (Bakery)

Standard Features

- Breeze™ Refrigeration System (See page 1)
- Three adjustable/removable glass shelves (18"D,22"D,26"D)
- Two cutaway with glass end panels
- Clear glass rear sliding doors
- Curved single pane lift-up front glass
- Straight laminated front panel
- T-8 top light and shelf lights
- 6' power cord
- Integrated average product temperature of 41°F
- ETL sanitation conforms to NSF 7
- ETL Listed Certified to CAN/CSA 22.2
- 1 year parts and labor; 5 year compressor warranty

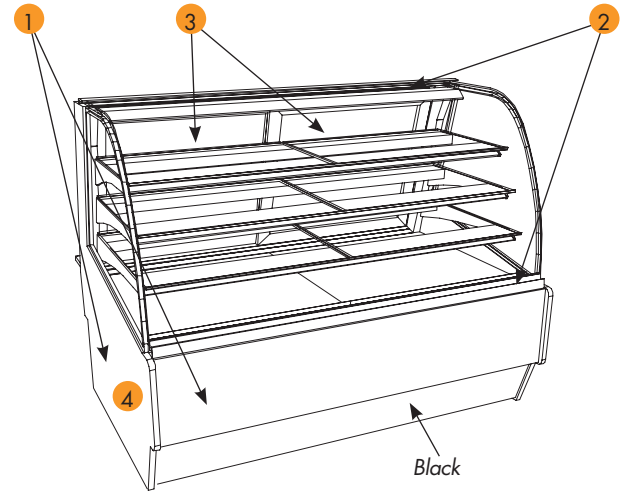

RBG5948R

| MODEL | RBG4848R | RBG5948R | RBG7748R |
|------------|------------------------|------------------------|------------------------|
| Dimensions | 48"L x 38"D x 48 1/4"H | 59"L x 38"D x 48 1/4"H | 77"L x 38"D x 48 1/4"H |
| List \$ | \$17,530 | \$17,755 | \$19,364 |

Dimensions shown are not exact. Refer to Factory Specification drawings for more detail.

| Product Specification | Standard (N/C) | Option(s) | List \$ |
|--|---|--|--|
| Interior Color* ¹ | Black | White Stainless Steel | N/C \$1,980 |
| Exterior Color* ¹ | Choice of Wilsonart® or Formica® non-premium laminates | Wilsonart® or Formica® premium laminates (as noted in laminate charts) Other manufacturer's laminates Stainless Steel Oak veneer with clear sealer Oak veneer stained (color match required) | \$620 Call for quote \$1,250 \$1,700 \$1,930 |
| Trim Color* ² | Black | Silver | N/C |
| Upper Rear* ³ | Clear glass sliding doors | Reflective glass sliding doors | \$260 |
| End Panel Style* ⁴ | Cutaway with glass | Full with mirror | \$190/end |
| Base* | Levelers | Casters (not available with remote refrigeration)** 6"H legs (increases height of case 6") | \$340 \$350 |
| Refrigeration* | Breeze™ self-contained w/ evaporator pan (rear air intake/front air discharge over glass) | Remote (compressor supplied by others) Pressure release valve (required for city of Chicago - must be ordered with case) | Call for quote \$50 |
| Miscellaneous (Must be chosen when case is ordered) | | Rear door lock Front glass lock Front package ledge, 6 3/4"D Scale stand with appliance receptacle (requires separate electrical) Second year parts & labor warranty (excludes compressor) | \$210 \$210 \$580 \$360 \$530 |
| Accessories (Can be purchased at any time. Refer to pages 76/77 for information) | | Rear wrapping board, 8"D | \$450 |

*Must choose one when placing order

**May increase height of case - refer to specification sheet

| MODEL | WEIGHT | Self-Contained Refrigeration/Dry | | | Remote Refrigeration with Leads | | |
|----------|--------|----------------------------------|-------|-----------|---------------------------------|------|-------|
| | | VOLTS | AMPS | NEMA PLUG | VOLTS | AMPS | BTUH |
| RBG4848R | 850 | 120/1/60 | 16.8 | 5-20P | 120/1/60 | 2.24 | NA |
| RBG5948R | 950 | 120/1/60 | 16.85 | 5-20P | 120/1/60 | 2.29 | 2,330 |
| RBG7748R | 1,100 | 120/1/60 | 17.23 | 5-20P | 120/1/60 | 2.67 | 2,904 |

Freight Class: 110

NOTE: Freight rate subject to linear foot rule.

Based on operating conditions of 75°F and 55% relative humidity. Specifications and pricing subject to change without notice.

Non-Refrigerated Service Case (Bakery)

Standard Features

- Three adjustable/removable wire shelves (18"D,22"D,26"D)
- Two cutaway with glass end panels
- Clear glass rear sliding doors
- Curved single pane lift-up front glass
- Straight laminated front panel
- T-8 top light and shelf lights
- 12" power cord
- Integrated average product temperature of 41°F
- UL Certified to NSF Standard 2
- 1 year parts and labor warranty

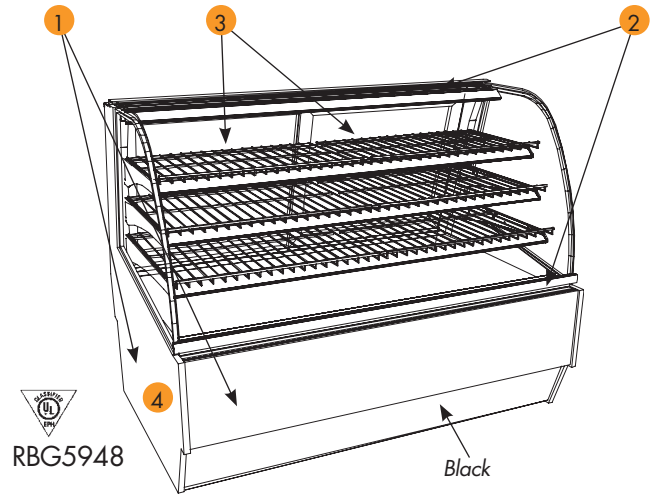

| MODEL | RBG4848 | RBG5948 | RBG7748 |
|------------|------------------------|------------------------|------------------------|
| Dimensions | 48"L x 38"D x 48 1/4"H | 59"L x 38"D x 48 1/4"H | 77"L x 38"D x 48 1/4"H |
| List \$ | \$11,234 | \$12,284 | \$13,328 |

Dimensions shown are not exact. Refer to Factory Specification drawings for more detail.

| Product Specification | Standard (N/C) | Option(s) | List \$ |
|---|--|--|--|
| Interior Color* | Black | White Stainless Steel | N/C \$1,980 |
| Exterior Color* ¹ | Choice of Wilsonart® or Formica® non-premium laminates | Wilsonart® or Formica® premium laminates (as noted in laminate charts) Other manufacturer's laminates Stainless Steel Oak veneer with clear sealer Oak veneer stained (color match required) | \$620 Call for quote \$1,250 \$1,700 \$1,930 |
| Trim Color* ² | Black | Silver | N/C |
| Shelving* | Wire racks | Clear glass | \$310 |
| Upper Rear* ³ | Clear glass sliding doors | Reflective glass sliding doors | \$260 |
| End Panel Style* ⁴ | Cutaway with glass | Full with mirror | \$190/end |
| Base* | Levelers | Castors** 6"H legs (increases height of case 6") | \$340 \$350 |
| Miscellaneous (Must be chosen when case is ordered) | | Rear door lock Front glass lock Front package ledge, 6-3/4"D Scale stand with appliance receptacle (requires separate electrical) Second year parts & labor warranty | \$210 \$210 \$580 \$360 \$530 |
| Accessories (Can be purchased at any time. Refer to pages 76/77 for information) | | Rear wrapping board, 8"D | \$450 |

*Must choose one when placing order

**May increase height of case - refer to specification sheet

| TRAY CAPACITY* | RBG4848* | RBG5948* | RBG7748* |
|--------------------|-----------------|-----------------|-----------------|
| Top Shelf - 18" | (4) 12x18 trays | (4) 12x18 trays | (6) 12x18 trays |
| Second Shelf - 22" | (4) 12x18 trays | (4) 12x18 trays | (6) 12x18 trays |
| Third Shelf - 26" | (2) 18x26 trays | (3) 18x26 trays | (4) 18x26 trays |

*Trays not supplied with unit

| MODEL | WEIGHT | Self-Contained Refrigeration/Dry | | | |
|---------|--------|----------------------------------|------|-----|-----------|
| | | VOLTS | AMPS | H/P | NEMA PLUG |
| RBG4848 | 660 | 120/1/60 | .94 | N/A | 5-15P |
| RBG5948 | 900 | 120/1/60 | .94 | N/A | 5-15P |
| RBG7748 | 1,000 | 120/1/60 | 1.32 | N/A | 5-15P |

Freight Class: 125 NOTE: Freight rate subject to linear foot rule.

Based on operating conditions of 75°F and 55% relative humidity.
Specifications and pricing subject to change without notice.

Combination Refrigerated Service Beside Non-Refrigerated Service Case (Bakery)

Standard Features

- Breeze™ Refrigeration System (See page 1)
- Interior display area split 1/2 refrigerated & 1/2 non-refrigerated
- Three adjustable/removable glass shelves on each side (18"D, 22"D, 26"D)
- Two cutaway with glass end panels
- Clear glass rear sliding doors
- Curved single pane lift-up front glass
- Straight laminated front panel
- T-8 top light and shelf lights
- 6' power cord
- Integrated average product temperature of 41°F
- ETL sanitation conforms to NSF 7
- 1 year parts and labor; 5 year compressor warranty

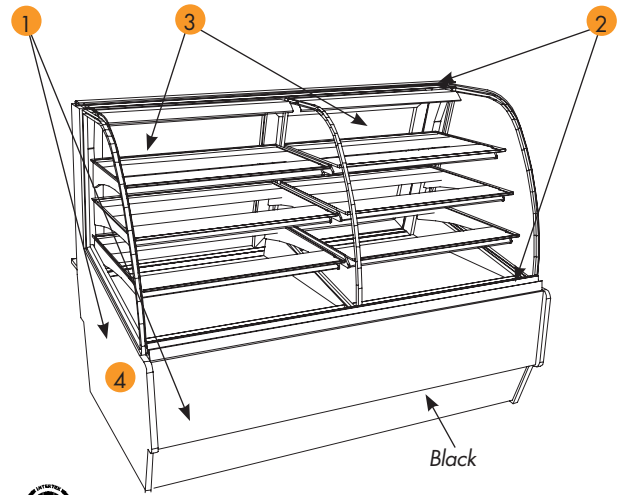

ETL
RB5C5948LR

| MODEL | RB5C4848LR | RB5C5948LR | RB5C7748LR |
|------------|------------------------|------------------------|------------------------|
| Dimensions | 48"L x 38"D x 48 1/4"H | 59"L x 38"D x 48 1/4"H | 77"L x 38"D x 48 1/4"H |
| List \$ | \$17,994 | \$18,808 | \$19,560 |

Dimensions shown are not exact. Refer to Factory Specification drawings for more detail.

| Product Specification | Standard (N/C) | Option(s) | List \$ |
|--|--|--|--|
| Interior Color* | Black | White Stainless Steel | N/C \$1,980 |
| Exterior Color* ¹ | Choice of Wilsonart® or Formica® non-premium laminates | Wilsonart® or Formica® premium laminates (as noted in laminate charts) Other manufacturer's laminates Stainless Steel Oak veneer with clear sealer Oak veneer stained (color match required) | \$620 Call for quote \$1,250 \$1,700 \$1,930 |
| Trim Color* ² | Black | Silver | N/C |
| Upper Rear* ³ | Clear glass sliding doors | Reflective glass sliding doors | \$260 |
| End Panel Style* ⁴ | Cutaway with glass | Full with mirror | \$190/end |
| Base* | Levelers | Castors (not available with remote refrigeration)** 6"H legs (increases height of case 6") | \$340 \$350 |
| Refrigeration* | Breeze™ self-contained w/ evaporator pan (rear air intake/ front air discharge over glass) | Remote (compressor supplied by others) Pressure release valve (required for city of Chicago - must be ordered with case) | Call for quote \$50 |
| Miscellaneous (Must be chosen when case is ordered) | | Rear door lock Front glass lock Front package ledge, 6-3/4"D Scale stand with appliance receptacle (requires separate electrical) Second year parts & labor warranty (excludes compressor) | \$210 \$210 \$580 \$360 \$530 |
| Accessories (Can be purchased at any time. Refer to pages 76/77 for information) | | Rear wrapping board, 8"D | \$450 |

*Must choose one when placing order

**May increase height of case - refer to specification sheet

| MODEL | WEIGHT | Self-Contained Refrigeration/Dry | | | Remote Refrigeration with Leads | | |
|------------|--------|----------------------------------|-------|-----------|---------------------------------|------|-------|
| | | VOLTS | AMPS | NEMA PLUG | VOLTS | AMPS | BTUH |
| RB5C4848LR | 870 | 120/1/60 | 12.94 | 5-15P | 120/1/60 | 2.21 | 1,165 |
| RB5C5948LR | 880 | 120/1/60 | 13.96 | 5-15P | 120/1/60 | 3.23 | 1,165 |
| RB5C7748LR | 1,100 | 120/1/60 | 17.74 | 5-20P | 120/1/60 | 3.54 | 1,165 |

Freight Class: 110 NOTE: Freight rate subject to linear foot rule.

Based on operating conditions of 75°F and 55% relative humidity. Specifications and pricing subject to change without notice.

Refrigerated Service Case (Deli)

Standard Features

- Breeze™ Refrigeration System (See page 1)
- Two cutaway with glass end panels
- Curved single pane lift-up front glass
- Clear glass rear sliding doors
- Straight laminated front panel
- T-8 top light and shelf lights
- One lighted sheet metal shelf (11-1/2"D)
- 6' power cord
- Integrated average product temperature of 41 °F
- ETL sanitation conforms to NSF 7
- 1 year parts and labor; 5 year compressor warranty

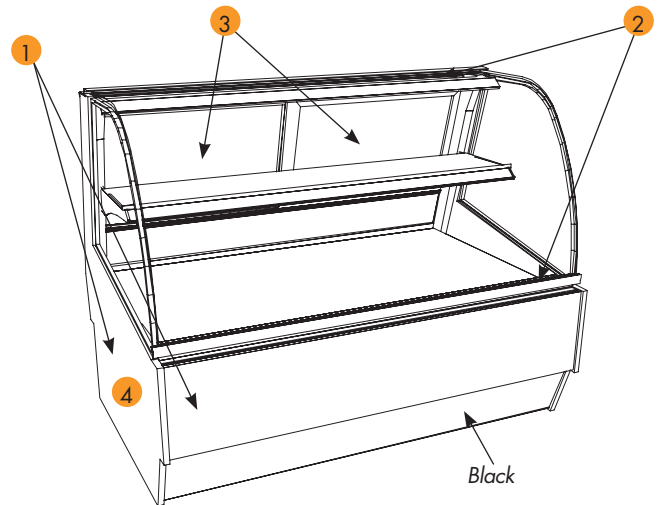

RDG5948R

| MODEL | RDG4848R | RDG5948R | RDG7748R |
|------------|------------------------|------------------------|------------------------|
| Dimensions | 48"L x 38"D x 48 1/4"H | 59"L x 38"D x 48 1/4"H | 77"L x 38"D x 48 1/4"H |
| List \$ | \$17,220 | \$17,507 | \$19,179 |

Dimensions shown are not exact. Refer to Factory Specification drawings for more detail.

| Product Specification | Standard (N/C) | Option(s) | List \$ |
|---|--|--|--|
| Interior Color* | Black | White Stainless Steel | N/C \$1,980 |
| Exterior Color* ¹ | Choice of Wilsonart® or Formica® non-premium laminates | Wilsonart® or Formica® premium laminates (as noted in laminate charts) Other manufacturer's laminates Stainless Steel Oak veneer with clear sealer Oak veneer stained (color match required) | \$620 Call for quote \$1,250 \$1,700 \$1,930 |
| Trim Color* ² | Black | Silver | N/C |
| Shelving* | One lighted shelf | 2"H Display step (in lieu of shelf) | \$390 |
| Upper Rear* ³ | Clear glass sliding doors | Reflective glass sliding doors | \$260 |
| End Panel Style* ⁴ | Cutaway with glass | Full with mirror | \$190/end |
| Base* | Levelers | Casters (not available with remote refrigeration)** 6"H legs (increases height of case 6") | \$340 \$350 |
| Refrigeration* | Breeze™ self-contained w/ evaporator pan (rear air intake/ front air discharge over glass) | Remote (compressor supplied by others) Pressure release valve (required for city of Chicago - must be ordered with case) | Call for quote \$50 |
| Miscellaneous (Must be chosen when case is ordered) | | Rear door lock Front glass lock Front package ledge, 6-3/4"D Scale stand with appliance receptacle (requires separate electrical) Second year parts & labor warranty (excludes compressor) | \$210 \$210 \$580 \$360 \$530 |
| Accessories (Can be purchased at any time. Refer to pages 76/77 for information) | | Rear wrapping board, 8"D | \$450 |

*Must choose one when placing order

**May increase height of case - refer to specification sheet

| MODEL | WEIGHT | Self-Contained Refrigeration/Dry | | | Remote Refrigeration with Leads | | |
|----------|--------|----------------------------------|-------|-----------|---------------------------------|------|-------|
| | | VOLTS | AMPS | NEMA PLUG | VOLTS | AMPS | BTUH |
| RDG4848R | 750 | 120/1/60 | 16.35 | 5-20P | 120/1/60 | 1.79 | 2,110 |
| RDG5948R | 850 | 120/1/60 | 16.4 | 5-20P | 120/1/60 | 2.01 | 2,330 |
| RDG7748R | 1,000 | 120/1/60 | 16.57 | 5-20P | 120/1/60 | 2.01 | 2,904 |

Freight Class: 110

NOTE: Freight rate subject to linear foot rule.

Based on operating conditions of 75°F and 55% relative humidity.
Specifications and pricing subject to change without notice.

Hot Service Case (Deli)

Standard Features

- Individually controlled stainless steel heated wells (dry heat)
 - RDG4848W - three full size & three one-third size pans
 - RDG7748W - five full size & five one-third size pans
- Stainless Steel interior
- Two cutaway with glass end panels
- Curved single pane lift-up front glass
- Straight laminated front panel
- Clear glass rear sliding doors
- Header lights with shatter resistant bulbs
- Infrared overhead heat (individually controlled)
- Integrated average product temperature of 160°F
- UL Certified to NSF Standard 4
- 1 year parts and labor warranty

Note: Pans not supplied with case.

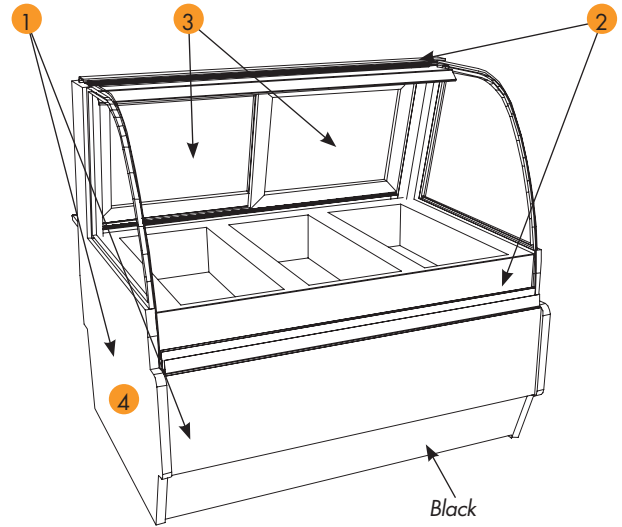

RDG4848W

| MODEL | RDG4848W | RDG7748W |
|------------|------------------------|------------------------|
| Dimensions | 48"L x 38"D x 48 1/4"H | 77"L x 38"D x 48 1/4"H |
| List \$ | \$17,131 | \$20,106 |

Dimensions shown are not exact. Refer to Factory Specification drawings for more detail.

| Product Specification | Standard (N/C) | Option(s) | List \$ |
|---|--|--|---|
| Exterior Color* ¹ | Choice of Wilsonart® or Formica® non-premium laminates | Wilsonart® or Formica® premium laminates (as noted in laminate charts) Other manufacturer's laminates Stainless Steel | \$620 Call for quote \$1,250 |
| Trim Color* ² | Black | Silver | N/C |
| Upper Rear* ³ | Clear glass sliding doors | Reflective glass sliding doors | \$260 |
| End Panel Style* ⁴ | Cutaway with glass | Full with mirror | \$190/end |
| Base* | Levelers | Casters** 6"H legs (increases height of case 6") | \$340 \$350 |
| Miscellaneous (Must be chosen when case is ordered) | | Rear door lock Front glass lock Front package ledge, 6-3/4"D Scale stand with appliance receptacle (requires separate electrical) Second year parts & labor warranty | \$210 \$210 \$580 \$360 \$530 |
| Accessories (Can be purchased at any time. Refer to pages 76/77 for information) | | Rear wrapping board, 8"D*** Power cord (RDG4848W/6-30P; RDG7748W/6-50P) | \$450 \$240 |

*Must choose one when placing order

**May increase height of case - refer to specification sheet

***Height of rear wrapping board does not match height of rear wrapping board on bakery case

| MODEL | WEIGHT | Self-Contained Refrigeration/Dry | | |
|----------|--------|----------------------------------|------|-----------|
| | | VOLTS | AMPS | NEMA PLUG |
| RDG4848W | 650 | 220/1/60* | 22.6 | Leads |
| RDG7748W | 950 | 220/1/60* | 38.9 | Leads |

Freight Class: 110 NOTE: Freight rate subject to linear foot rule.

*Requires three wires plus ground

Based on operating conditions of 75°F and 55% relative humidity. Specifications and pricing subject to change without notice.

Refrigerated Service Candy Case

Standard Features

- Breeze™ Refrigeration System (See page 1)
- Three adjustable/removable glass shelves (10"D, 12"D, 14"D)
- Two cutaway with glass end panels
- Curved single pane lift-up front glass
- Clear glass rear sliding doors
- Straight laminated front panel
- T-8 top light and shelf lights
- 6' power cord
- Integrated average product temperature of 65°F
- ETL sanitation conforms to NSF 7
- ETL Listed Certified to CAN/CSA 22.2
- 1 year parts and labor; 5 year compressor warranty

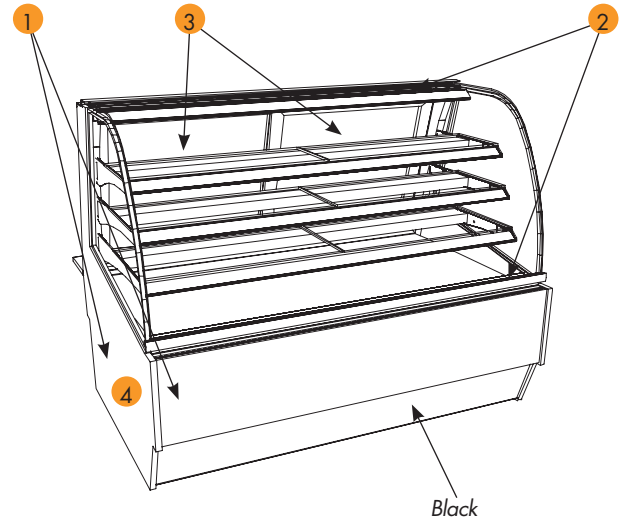

ETL
RCG5948R

| MODEL | RCG4848R | RCG5948R | RCG7748R |
|------------|------------------------|------------------------|------------------------|
| Dimensions | 48"L x 38"D x 48 1/4"H | 59"L x 38"D x 48 1/4"H | 77"L x 38"D x 48 1/4"H |
| List \$ | \$15,422 | \$16,279 | \$17,540 |

Dimensions shown are not exact. Refer to Factory Specification drawings for more detail.

| Product Specification | Standard (N/C) | Option(s) | List \$ |
|--|---|--|--|
| Interior Color* | Black | White Stainless Steel | N/C \$1,980 |
| Exterior Color* ¹ | Choice of Wilsonart® or Formica® non-premium laminates | Wilsonart® or Formica® premium laminates (as noted in laminate charts) Other manufacturer's laminates Stainless Steel Oak veneer with clear sealer Oak veneer stained (color match required) | \$620 Call for quote \$1,250 \$1,700 \$1,930 |
| Trim Color* ² | Black | Silver | N/C |
| Upper Rear* ³ | Clear glass sliding doors | Reflective glass sliding doors | \$260 |
| End Panel Style* ⁴ | Cutaway with glass | Full with mirror | \$190/end |
| Base* | Levelers | Casters (not available with remote refrigeration)** 6"H legs (increases height of case 6") | \$340 \$350 |
| Refrigeration* | Breeze™ self-contained w/ evaporator pan (rear air intake/front air discharge over glass) | Remote (compressor supplied by others) Pressure release valve (required for city of Chicago - must be ordered with case) | Call for quote \$50 |
| Miscellaneous (Must be chosen when case is ordered) | | Rear door lock Front glass lock Front package ledge, 6-3/4"D Second year parts & labor warranty (excludes compressor) | \$210 \$210 \$580 \$530 |
| Accessories (Can be purchased at any time. Refer to pages 76/77 for information) | | Rear wrapping board, 8"D Acrylic candy trays (refer to quantities below)*** | \$450 \$1,600 |

*Must choose one when placing order

**May increase height of case - refer to specification sheet

*** Acrylic Candy Tray Option:
RCG4848R option includes (6) 7x8 trays; (12) 7x14 trays
RCG5948R option includes (8) 7x8 trays; (16) 7x14 trays
RCG7748R option includes (10) 7x8 trays; (20) 7x14 trays

| MODEL | WEIGHT | Self-Contained Refrigeration/Dry | | | Remote Refrigeration with Leads | | |
|----------|--------|----------------------------------|------|-----------|---------------------------------|------|-------|
| | | VOLTS | AMPS | NEMA PLUG | VOLTS | AMPS | BTUH |
| RCG4848R | 800 | 120/1/60 | 8.57 | 5-15P | 120/1/60 | 1.39 | 1,169 |
| RCG5948R | 900 | 120/1/60 | 8.57 | 5-15P | 120/1/60 | 1.84 | 1,241 |
| RCG7748R | 1,000 | 120/1/60 | 8.95 | 5-15P | 120/1/60 | 2.22 | 1,624 |

Freight Class: 110 NOTE: Freight rate subject to linear foot rule. *Requires three wires plus ground

Based on operating conditions of 75°F and 55% relative humidity. Specifications and pricing subject to change without notice.

Refrigerated Open Air Screen Case

Standard Features

- Breeze™ Refrigeration System (See page 1)
- Two full end panels with mirror interior
- 4"D removable rear wall spacer bracket (not included in depth dimensions below)
- T-8 top light
- 6' power cord
- Integrated average product temperature of 41°F
- ETL sanitation conforms to NSF 7
- ETL Listed Certified to CAN/CSA 22.2
- 1 year parts and labor; 5 year compressor warranty

NOTE: Compressor air intake from front and out rear of case. Front panel cannot be blocked and case must remain 4" from wall.

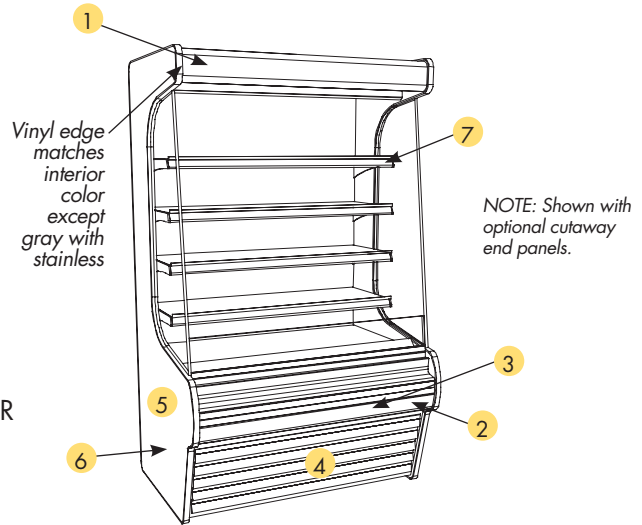

| MODEL | CO3678R | CO4778R | CO5978R | CO7178R |
|------------|------------------------|------------------------|------------------------|------------------------|
| Dimensions | 36"L x 34 3/4"D x 81"H | 47"L x 34 3/4"D x 81"H | 59"L x 34 3/4"D x 81"H | 71"L x 34 3/4"D x 81"H |
| List \$ | \$10,431 | \$11,167 | \$12,278 | \$13,139 |

Dimensions shown are not exact. Refer to Factory Specification drawings for more detail.

| Product Specification | Standard (N/C) | Option(s) | List \$ |
|--|--|---|--|
| Interior Color* | Black | White Stainless Steel | N/C \$2,090 |
| Header Color* 1 Curved Style | Curved-Black | Curved-White Curved-Stainless Steel Curved-Painted (specify color) Laminated (straight header style required) | N/C \$110 N/C \$150 |
| Upper Front Panel Style* 2 | Formed ABS (painted) | Straight front - reduces depth to 33 1/4" without wall spacer bracket | N/C |
| Upper Front Panel Color* 3 | Black | Painted - ABS front panel only (specify color) Stainless Steel (straight front panel required) Wilsonart® or Formica® non-premium laminates (straight front panel required) Wilsonart® or Formica® premium laminates (straight front panel required) | N/C \$250 N/C \$260 |
| Lower Louvered Front Panel Color* 4 | Black | White Stainless Steel Painted (specify color) | N/C \$110 N/C |
| End Panel Style* 5 | Full end with vinyl edging | Full end with laminate edging (Q4296) Cutaway end with vinyl edging Cutaway end with laminate edging (Q4296) Counter cutaway end with vinyl edging (Q4292) Counter cutaway end with laminate edging (Q4292) Case-to-case acrylic panel (straight front panel style only) | N/C \$180/end \$180/end \$240/end \$240/end N/C |
| End Panel Color* 6 | Black | Wilsonart® or Formica® non-premium laminates (as noted in laminate charts) Wilsonart® or Formica® premium laminates (as noted in laminate charts) Other manufacturer's laminates Stainless Steel | N/C \$260/end Call for quote \$790/end |
| Exterior Back Panel* | Solid panel - Galvanized | Solid panel - Black Rear loading hinged doors, locking** (matches interior color) (CO36) Rear loading hinged doors, locking** (matches interior color) (CO47,59 & 71) | \$120 \$1,650 \$2,610 |
| Shelving* 7 | (4) Non-lighted sheet metal | (4) Lighted shelves Additional non-lighted shelf Additional lighted shelf Magna bar peg hooks (in lieu of shelves) | \$890 \$260 \$330 \$160 |
| Base* | Casters | Levelers | N/C |
| Refrigeration* | Breeze™ self-contained w/ evaporator pan (front air intake/rear air discharge) | Remote (compressor supplied by others) Pressure release valve (required for city of Chicago) - must be ordered with case Breeze-E with Whisper Cool | Call for quote \$50 \$1,700 |
| Miscellaneous (Must be chosen when case is ordered) | | Roll-down security cover, locking (increases height of case by 7")(CO36 & 47) Roll-down security cover, locking (increases height of case by 7")(CO59 & 71) Clean Sweep® automatic condenser coil cleaner Second year parts & labor warranty (excludes compressor) | \$1,850 \$2,780 \$990 \$530 |
| Accessories (Can be purchased at any time. Refer to pages 76/77 for information) | | Price tag molding Night curtain, pull-down, non-locking Removable solid security cover, locking, Stardust Silver paint | \$130 \$420 \$920 |

*Must choose one when placing order **Minimum 40" door entry clearance required. Depth of unit with rear door 38 1/4". Doors are not removable.

Contact factory for technical electrical information.

| MODEL | CO3678R | CO4778R | CO5978R | CO7178R |
|--------|---------|---------|---------|---------|
| WEIGHT | 960 | 1,150 | 1,350 | 1,550 |

Freight Class: 110 NOTE: Freight rate subject to linear foot rule.

Based on operating conditions of 75°F and 55% relative humidity. Specifications and pricing subject to change without notice.

Refrigerated Open Air Screen Case

Standard Features

- Breeze™ Refrigeration System (See page 1)
- Two full end panels with mirror interior
- 4"D removable rear wall spacer bracket (not included in depth dimensions below)
- T-8 top light
- 6' power cord
- Integrated average product temperature of 41 °F
- ETL sanitation conforms to NSF 7
- ETL Listed Certified to CAN/CSA 22.2
- 1 year parts and labor; 5 year compressor warranty

NOTE: Compressor air intake from front and out rear of case.
Front panel cannot be blocked and case must remain 4" from wall.

Quick-Ship
See page 10

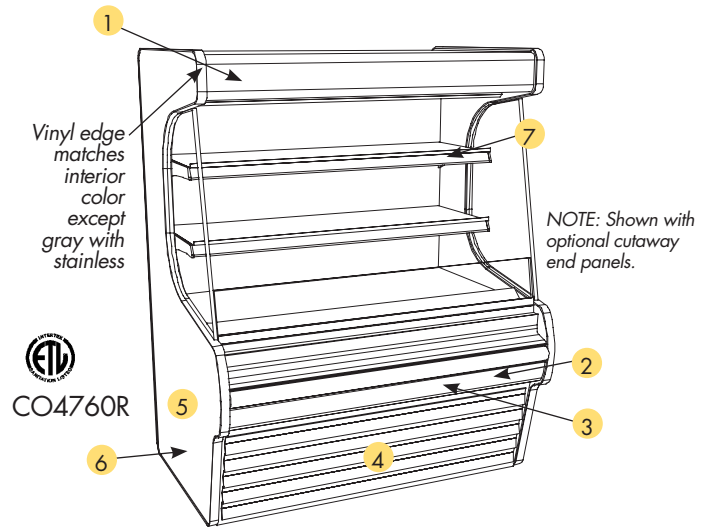

| MODEL | CO3660R | CO4760R | CO5960R | CO7160R |
|------------|----------------------------|----------------------------|----------------------------|----------------------------|
| Dimensions | 36"L x 34 3/4"D x 63 1/8"H | 47"L x 34 3/4"D x 63 1/8"H | 59"L x 34 3/4"D x 63 1/8"H | 71"L x 34 3/4"D x 63 1/8"H |
| List \$ | \$9,842 | \$10,591 | \$11,616 | \$12,372 |

Dimensions shown are not exact. Refer to Factory Specification drawings for more detail.

| Product Specification | Standard (N/C) | Option(s) | List \$ |
|--|---|---|--|
| Interior Color* | Black | White Stainless Steel | N/C \$2,090 |
| Header Color* ¹ Curved Style | Curved-Black | Curved-White Curved-Stainless Steel Curved-Painted (specify color) Laminated (straight header style required) | N/C \$110 N/C \$150 |
| Upper Front Panel Style* ² | Formed ABS (painted) | Straight front - reduces depth to 33 1/4" without wall spacer bracket | N/C |
| Upper Front Panel Color* ³ | Black | Painted - ABS front panel only (specify color) Stainless Steel (straight front panel required) Wilsonart® or Formica® non-premium laminates (straight front panel required) Wilsonart® or Formica® premium laminates (straight front panel required) | N/C \$250 N/C \$260 |
| Lower Louvered Front Panel Color* ⁴ | Black | White Stainless Steel Painted (specify color) | N/C \$110 N/C |
| End Panel Style* ⁵ | Full end with vinyl edging | Full end with laminate edging (Q4296) Cutaway end with vinyl edging Cutaway end with laminate edging (Q4296) Counter cutaway end with vinyl edging (Q4292) Counter cutaway end with laminate edging (Q4292) Case-to-case acrylic panel (straight front panel style only) | N/C \$180/end \$180/end \$240/end \$240/end N/C |
| End Panel Color* ⁶ | Black | Wilsonart® or Formica® non-premium laminates (as noted in laminate charts) Wilsonart® or Formica® premium laminates (as noted in laminate charts) Other manufacturer's laminates Stainless Steel | N/C \$260/end Call for quote \$790/end |
| Exterior Back Panel* | Solid panel - Galvanized | Solid panel - Black Rear loading hinged doors, locking** (matches interior color) (CO36) Rear loading hinged doors, locking** (matches interior color) (CO47, 59 & 71) | \$120 \$1,650 \$2,610 |
| Shelving* ⁷ | (2) Non-lighted sheet metal | (2) Lighted shelves Additional non-lighted shelf Additional lighted shelf Magna bar peg hooks (in lieu of shelves) | \$890 \$260 \$330 \$160 |
| Base* | Casters | Levelers | N/C |
| Refrigeration* | Breeze™ self-contained w/ evaporator pan (front air intake/ rear air discharge) | Remote (compressor supplied by others) Pressure release valve (required for city of Chicago) - must be ordered with case Breeze-E with Whisper Cool | Call for quote \$50 \$1,425 |
| Miscellaneous (Must be chosen when case is ordered) | | Roll-down security cover, locking (increases height of case by 7") (CO36 & 47) Roll-down security cover, locking (increases height of case by 7") (CO59 & 71) Clean Sweep® automatic condenser coil cleaner Second year parts & labor warranty (excludes compressor) | \$1,850 \$2,780 \$990 \$530 |
| Accessories (Can be purchased at any time. Refer to pages 76/77 for information) | | Price tag molding Night curtain, pull-down, non-locking Removable solid security cover, locking, Stardust Silver paint | \$130 \$420 \$920 |

*Must choose one when placing order

**Minimum 40" door entry clearance required. Depth of unit with rear door 38 1/4". Doors are not removable.

Contact factory for technical electrical information.

| MODEL | CO3660R | CO4760R | CO5960R | CO7160R |
|--------|---------|---------|---------|---------|
| WEIGHT | 960 | 1,150 | 1,350 | 1,550 |

Freight Class: 110 NOTE: Freight rate subject to linear foot rule.

Based on operating conditions of 75°F and 55% relative humidity.
Specifications and pricing subject to change without notice.

Refrigerated Open Air Screen Case

Standard Features

- Breeze™ Refrigeration System (See page 1)
- Two full end panels
- Two non-lighted shelves (8"D & 15"D)
- T-8 top light
- 6' power cord
- Integrated average product temperature of 41 °F
- ETL sanitation conforms to NSF 7
- ETL Listed Certified to CAN/CSA 22.2
- 1 year parts and labor; 5 year compressor warranty

NOTE: Compressor air intake from front and out rear of case. Front panel cannot be blocked and case must remain 4" from wall.

Quick-Ship
See page 10

CO4748R

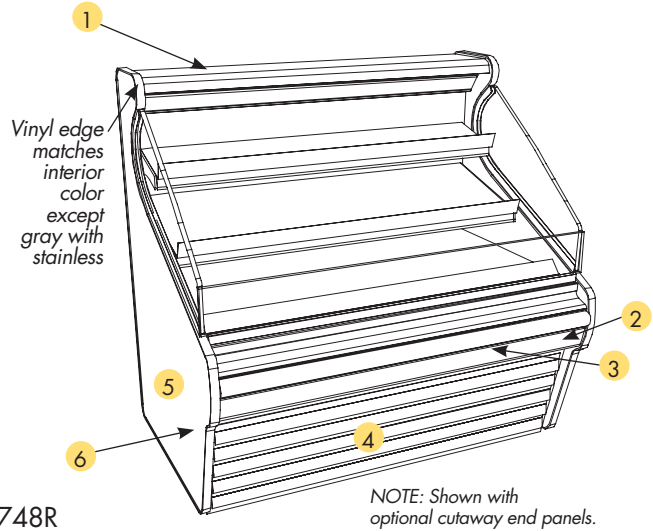

| MODEL | CO4748R |
|------------|----------------------------|
| Dimensions | 47"L x 34 3/4"D x 50 5/8"H |
| List \$ | \$10,346 |

Dimensions shown are not exact. Refer to Factory Specification drawings for more detail.

| Product Specification | Standard (N/C) | Option(s) | List \$ |
|---|--|---|--|
| Interior Color* | Black | White Stainless Steel | N/C \$2,090 |
| Header Color* ¹ | Black | White Stainless Steel Painted (specify color) | N/C \$110 N/C |
| Upper Front Panel Style* ² | Formed ABS (painted) | Straight front - reduces depth to 33 1/4" without wall spacer bracket | N/C |
| Upper Front Panel Color* ³ | Black | Painted - ABS front panel only (specify color) Stainless Steel (straight front panel required) Wilsonart® or Formica® non-premium laminates (straight front panel required) Wilsonart® or Formica® premium laminates (straight front panel required) | N/C \$250 N/C \$260 |
| Lower Louvered Front Panel Color* ⁴ | Black | White Stainless Steel Painted (specify color) | N/C \$110 N/C |
| End Panel Style* ⁵ | Full end with vinyl edging | Full end with laminate edging (Q4296) Cutaway end with vinyl edging Cutaway end with laminate edging (Q4296) Counter cutaway end with vinyl edging (Q4292) Counter cutaway end with laminate edging (Q4292) Case-to-case acrylic panel (straight front panel style only) | N/C \$180/end \$180/end \$240/end \$240/end N/C |
| End Panel Color* ⁶ | Black | Wilsonart® or Formica® non-premium laminates (as noted in laminate charts) Wilsonart® or Formica® premium laminates (as noted in laminate charts) Other manufacturer's laminates Stainless Steel | N/C \$260/end Call for quote \$790/end |
| Back Panel* | Solid panel - Galvanized | Solid panel - Black | \$120 |
| Base* | Casters | Levelers | N/C |
| Refrigeration* | Breeze™ self-contained w/ evaporator pan (front air intake/rear air discharge) | Remote (compressor supplied by others) Pressure release valve (required for city of Chicago) - must be ordered with case Breeze-E with Whisper Cool | Call for quote \$50 \$1,425 |
| Miscellaneous (Must be chosen when case is ordered) | | Roll-down security cover, locking (increases height of case by 5") Clean Sweep® automatic condenser coil cleaner Second year parts & labor warranty (excludes compressor) | \$1,850 \$990 \$530 |
| Accessories (Can be purchased at any time. Refer to pages 76/77 for information) | | Price tag molding Night curtain, pull-down, non-locking Removable solid security cover, locking | \$130 \$420 \$920 |

*Must choose one when placing order

| MODEL | WEIGHT | Self-Contained Refrigeration/Dry | | | Remote Refrigeration with Leads | | |
|---------|--------|--|------|-----------|---------------------------------|------|------|
| | | VOLTS | AMPS | NEMA PLUG | VOLTS | AMPS | BTUH |
| CO4748R | 740 | Contact factory for technical electrical information. | | | | | |

Freight Class: 110 NOTE: Freight rate subject to linear foot rule.

Based on operating conditions of 75°F and 55% relative humidity. Specifications and pricing subject to change without notice.

34"D Refrigerated Open Air Screen Case

Standard Features

- Two full end panels with mirror interior
- T-8 top light
- Angled bottom deck
- Four casters
- 6' power cord
- Integrated average product temperature of 41°F
- ETL sanitation conforms to NSF 7
- 1 year parts and labor; 5 year compressor warranty

NOTE: Compressor air intake from rear and out front panel at toe kick. Front panel cannot be blocked.

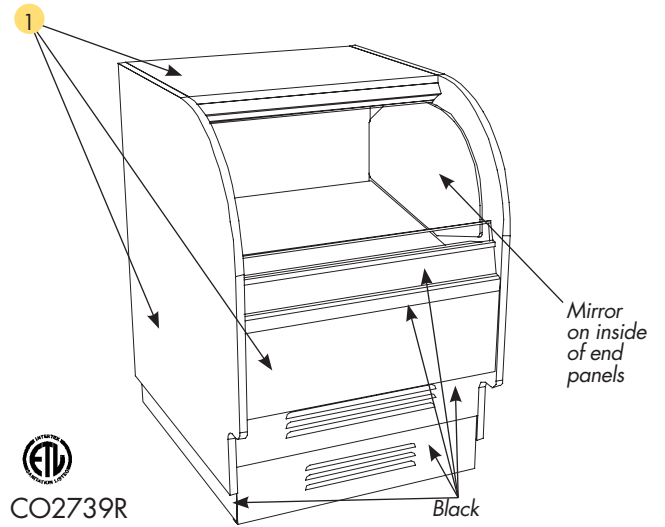

| MODEL | CO2739R |
|------------|------------------------|
| Dimensions | 28"L x 34"D x 39 1/4"H |
| List \$ | \$7,134 |

Dimensions shown are not exact. Refer to Factory Specification drawings for more detail.

| Product Specification | Standard (N/C) | Option(s) | List \$ |
|---|--|---|----------------------------------|
| Interior Color* | Black | White Stainless Steel | N/C \$1,090 |
| Exterior Color* ¹ | Choice of Wilsonart® or Formica® non-premium laminates | Wilsonart® or Formica® premium laminates (as noted in laminate charts) Other manufacturer's laminates Stainless Steel | \$620 Call for quote \$700 |
| Refrigeration* | Breeze™ self-contained w/ evaporator pan (rear air intake/ front air discharge at toe kick.) | Remote (compressor supplied by others) Pressure release valve (required for city of Chicago) - must be ordered with case | Call for quote \$50 |
| Miscellaneous (Must be chosen when case is ordered) | | Second year parts & labor warranty (excludes compressor) | \$530 |
| Accessories (Can be purchased at any time. Refer to pages 76/77 for information) | | Display steps (2"H) Removable wire security cover, locking Night curtain, pull-down, non-locking | \$480 \$500 \$420 |

*Must choose one when placing order

| MODEL | WEIGHT | Self-Contained Refrigeration/Dry | | | Remote Refrigeration with Leads | | |
|---------|--------|----------------------------------|------|-----------|---------------------------------|------|-------|
| | | VOLTS | AMPS | NEMA PLUG | VOLTS | AMPS | BTUH |
| CO2739R | 475 | 120/1/60 | 6.1 | 5-15P | 120/1/60 | 0.82 | 1,296 |

Freight Class: 110 NOTE: Freight rate subject to linear foot rule.

Based on operating conditions of 75°F and 55% relative humidity. Specifications and pricing subject to change without notice.

24"D Refrigerated Open Air Screen Case

Standard Features

- Breeze™ Refrigeration System (See page 1)
- Two full end panels (no mirror inside)
- T-8 top light
- Four adjustable/removable non-lighted shelves (15"D)
- 6' power cord
- Integrated average product temperature of 41°F
- ETL sanitation conforms to NSF 7
- ETL Listed Certified to CAN/CSA 22.2
- 1 year parts and labor; 5 year compressor warranty

NOTE: Compressor air intake through front panel.
Front panel cannot be blocked.

NOTE: Top of header area must not be obstructed if positioned in an alcove.

Quick-Ship
See page 10

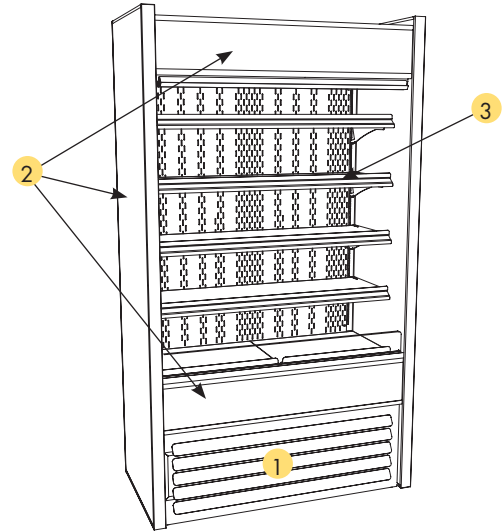

This model may require additional lead time

| MODEL | B32 | B42 | B62 | B82 |
|------------|--------------------|--------------------|--------------------|--------------------|
| Dimensions | 34"L x 24"D x 82"H | 45"L x 24"D x 82"H | 66"L x 24"D x 82"H | 88"L x 24"D x 82"H |
| List \$ | \$9,909 | \$10,610 | \$12,482 | \$16,790 |

Dimensions shown are not exact. Refer to Factory Specification drawings for more detail.

| Product Specification | Standard (N/C) | Option(s) | List \$ |
|---|--|--|--|
| Interior Color* | Black | White Stainless Steel | N/C \$2,090 |
| Lower Front Panel Color* ¹ | Black | White Stainless Steel | N/C \$110 |
| Exterior Color* ² | Black | White Stainless Steel Wilsonart® or Formica® non-premium laminates (as noted in laminate charts) Wilsonart® or Formica® premium laminates (as noted in laminate charts) Other manufacturer's laminates | N/C \$1,520 N/C \$620 Call for quote |
| Rear Panel* | Solid panel - Black | Solid panel - White | \$120 |
| Shelving* ³ | Non-lighted shelves | Lighted shelves | \$890 |
| Base* | Casters** | Levelers | N/C |
| Refrigeration* | Breeze™ self-contained w/ evaporator pan (front air intake/ upper front air discharge) | Remote (compressor supplied by others) Pressure release valve (required for city of Chicago) - must be ordered with case | Call for quote \$50 |
| Miscellaneous (Must be chosen when case is ordered) | | Clean Sweep® automatic condenser coil cleaner Second year parts & labor warranty (excludes compressor) | \$990 \$530 |
| Accessories (Can be purchased at any time. Refer to pages 76/77 for information) | | Price tag molding Night curtain, pull-down, non-locking Removable solid security cover, locking, Stardust Silver paint | \$130 \$420 \$920 |

*Must choose one when placing order

**Not available with remote refrigeration

| MODEL | WEIGHT | Self-Contained Refrigeration/Dry | | | Remote Refrigeration with Leads | | |
|-------|--------|----------------------------------|-------|-----------|---------------------------------|------|--------|
| | | VOLTS | AMPS | NEMA PLUG | VOLTS | AMPS | BTUH |
| B32 | 610 | 120/1/60 | 16.41 | 5-20P | 120/1/60 | 2.06 | 5,924 |
| B42 | 700 | 220/1/60* | 14.94 | 14-20P | 120/1/60 | 2.52 | 7,511 |
| B62 | 790 | 220/1/60* | 21.39 | 14-30P | 120/1/60 | 4.52 | 11,647 |
| B82 | 900 | 220/1/60* | 26.78 | 14-30P | 120/1/60 | 4.75 | 15,038 |

Freight Class: 110 NOTE: Freight rate subject to linear foot rule. *Requires three wires plus ground

Based on operating conditions of 75°F and 55% relative humidity.
Specifications and pricing subject to change without notice.

Refrigerated Open Air Screen Case

Standard Features

- Two cutaway end panels with acrylic
- One non-lighted interior shelf (10"D) (MP5348RSS only)
- T-8 top light (excludes MP3848RSS)
- Locking casters
- 6' power cord
- Integrated average product temperature of 41 °F
- ETL sanitation conforms to NSF 7
- ETL Listed Certified to CAN/CSA 22.2
- 1 year parts and labor; 5 year compressor warranty

NOTE: Compressor air intake from rear and out front panel at toe kick. Front panel cannot be blocked.

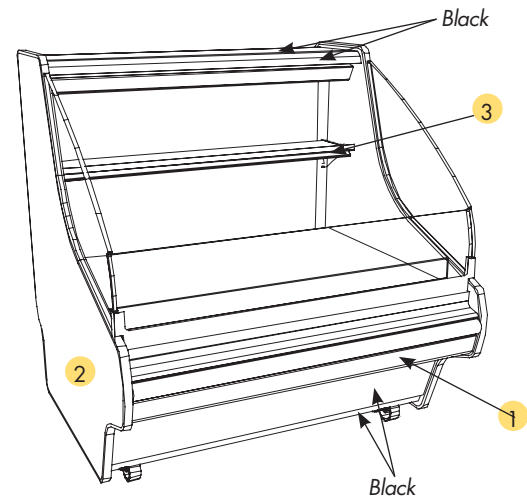

MP5348RSS

| MODEL | MP3848RSS | MP4448RSS | MP5348RSS |
|------------|----------------------------|--------------------------------|----------------------------|
| Dimensions | 50 1/2"L x 49 1/2"D x 38"H | 50 1/2"L x 49 1/2"D x 43 5/8"H | 50 1/2"L x 49 1/2"D x 53"H |
| List \$ | \$9,823 | \$10,757 | \$13,026 |

Dimensions shown are not exact. Refer to Factory Specification drawings for more detail.

| Product Specification | Standard (N/C) | Option(s) | List \$ |
|---|---|--|------------------------------------|
| Interior Color* | Black | White | N/C |
| Upper Front Panel Color* ¹ | Black | Painted (specify color) | N/C |
| End Panel Color* ² | Black | Wilsonart® or Formica® non-premium laminates (as noted in laminate charts) Wilsonart® or Formica® premium laminates (as noted in laminate charts) Other manufacturer's laminates | N/C \$260/end Call for quote |
| Shelving* ³ | Non-lighted shelf (MP5348RSS only) | Lighted shelf (MP5348RSS only) Additional 18"D non-lighted shelf (MP5348RSS only) Additional 18"D lighted shelf (MP5348RSS only) Display steps (N/A with MP5348RSS) | \$190 \$390 \$540 \$130 |
| Refrigeration* | Self-contained w/evaporator pan (rear air intake/front air discharge at toe kick) | Remote (compressor supplied by others) Pressure release valve (required for city of Chicago) - must be ordered with case | Call for quote \$50 |
| Miscellaneous (Must be chosen when case is ordered) | | Second year parts & labor warranty (excludes compressor) | \$530 |

*Must choose one when placing order

| MODEL | WEIGHT | Self-Contained Refrigeration/Dry | | | Remote Refrigeration with Leads | | |
|-----------|--------|----------------------------------|-------|-----------|---------------------------------|--------------|--------------|
| | | VOLTS | AMPS | NEMA PLUG | VOLTS | AMPS | BTUH |
| MP3848RSS | 680 | 120/1/60 | 17.15 | 5-20P | 120/1/60 | Call Factory | Call Factory |
| MP4448RSS | 680 | 120/1/60 | 17.46 | 5-20P | 120/1/60 | Call Factory | Call Factory |
| MP5348RSS | 720 | 120/1/60 | 16.47 | 5-20P | 120/1/60 | 2.21 | 5,902 |

Freight Class: 110

NOTE: Freight rate subject to linear foot rule.

Based on operating conditions of 75°F and 55% relative humidity. Specifications and pricing subject to change without notice.

Non-Refrigerated Self-Service Case

Standard Features

- Two full end panels
- T-8 top light
- Four adjustable/removable non-lighted metal shelves
 - Two non-lighted metal shelves (CO4748)
- 12" power cord
- ETL Listed Certified to CAN/CSA 22.2
- 1 year parts and labor warranty

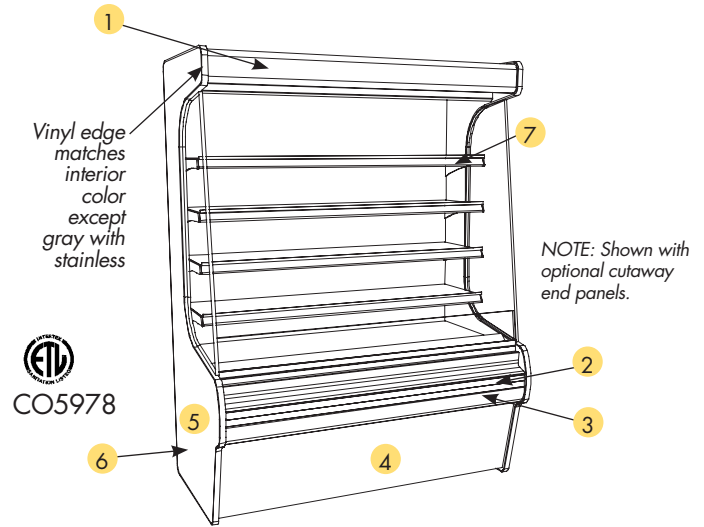

| MODEL | CO4748 | CO3678 | CO4778 | CO5978 | CO7178 |
|------------|----------------------------|------------------------|------------------------|------------------------|------------------------|
| Dimensions | 47"L x 34 3/4"D x 50 5/8"H | 36"L x 34 3/4"D x 81"H | 47"L x 34 3/4"D x 81"H | 59"L x 34 3/4"D x 81"H | 71"L x 34 3/4"D x 81"H |
| List \$ | \$6,803 | \$7,495 | \$7,835 | \$8,175 | \$8,502 |

Dimensions shown are not exact. Refer to Factory Specification drawings for more detail.

| Product Specification | Standard (N/C) | Option(s) | List \$ |
|--|----------------------------|---|---|
| Interior Color* | Black | White Stainless Steel | N/C \$2,090 |
| Header Color* ¹ Curved Style (excludes CO4748) | Curved-Black | Curved-White Curved-Stainless Steel Curved-Painted (specify color) Laminated (Straight header style required) (N/A on CO4748) | N/C \$110 N/C \$150 |
| Upper Front Panel Style* ² | Formed ABS (painted) | Straight front - reduces depth to 33 1/4" without wall spacer bracket | N/C |
| Upper Front Panel Color* ³ | Black | Painted - ABS front panel only (specify color) Stainless Steel (straight front panel required) Wilsonart® or Formica® non-premium laminates (straight front panel required) Wilsonart® or Formica® premium laminates (straight front panel required) | N/C \$250 N/C \$260 |
| Lower Front Panel Color* ⁴ | Black | White Stainless Steel Painted (specify color) | N/C \$110 N/C |
| End Panel Style* ⁵ | Full end with vinyl edging | Full end with laminate edging (Q4296) Cutaway end with vinyl edging Cutaway end with laminate edging (Q4296) Counter cutaway end with vinyl edging (Q4292) Counter cutaway end with laminate edging (Q4292) | N/C \$180/end \$180/end \$240/end \$240/end |
| End Panel Color* ⁶ | Black | Wilsonart® or Formica® non-premium laminates (as noted in laminate charts) Wilsonart® or Formica® premium laminates (as noted in laminate charts) Other manufacturer's laminates Stainless Steel | N/C \$260/end Call for quote \$790/end |
| Back Panel* | Solid panel - Galvanized | Solid panel - Black | \$120 |
| Shelving* ⁷ | Non-lighted metal shelves | Lighted metal shelves (CO3678, 4778, 5978, 7178) Additional non-lighted shelf (CO3678, 4778, 5978, 7178) Additional lighted shelf (CO3678, 4778, 5978, 7178) | \$890 \$260 \$330 |
| Base* | Casters | Levelers | N/C |
| Miscellaneous (Must be chosen when case is ordered) | | Roll-down security cover, locking (increases height of case by 5") (CO4748) Roll-down security cover, locking (increases height of case by 7") (CO3678, 4778) Roll-down security cover, locking (increases height of case by 7") (CO5978, 7178) Second year parts & labor warranty | \$1,850 \$1,850 \$2,780 \$530 |
| Accessories (Can be purchased at any time. Refer to pages 76/77 for information) | | Price tag molding Removable solid security cover, locking, Stardust Silver paint Magna bar peg hooks (CO3678, 4778, 5978, 7178) | \$130 \$920 \$160 |

*Must choose one when placing order

**Note: 40" minimum door entry clearance is required

| MODEL | WEIGHT | Self-Contained Refrigeration/Dry | | |
|--------|--------|----------------------------------|------|-----------|
| | | VOLTS | AMPS | NEMA PLUG |
| CO4748 | 625 | 120/1/60 | 0.31 | 5-15P |
| CO3678 | 725 | 120/1/60 | 2.18 | 5-15P |
| CO4778 | 760 | 120/1/60 | 2.18 | 5-15P |
| CO5978 | 900 | 120/1/60 | 2.18 | 5-15P |
| CO7178 | 1,100 | 120/1/60 | 3.36 | 5-15P |

Freight Class: 125 NOTE: Freight rate subject to linear foot rule.

Based on operating conditions of 75°F and 55% relative humidity. Specifications and pricing subject to change without notice.

Combination Ambient/Refrigerated Service Above Refrigerated Self-Service Case

Standard Features

- Breeze™ Refrigeration System (See page 1)
- Upper service display area
 - Fixed front glass
 - Non-refrigerated with 12"D shelf and 14"D deck
 - Clear glass rear sliding doors
- Middle service display area
 - Fixed front glass
 - Single display level (15"D)
 - Baffle system converts from refrigerated to non-refrigerated
 - Clear glass rear sliding doors
- Lower self-service display area with open reach-in front and 17"D solid shelf
- Two full end panels with mirror interior (lower section)
- Rear wrapping board (13 1/4"D)
- T-8 top light and shelf lights
- 6' power cord
- Integrated average product temperature of 41°F
- ETL sanitation conforms to NSF 7
- 1 year parts and labor; 5 year compressor warranty

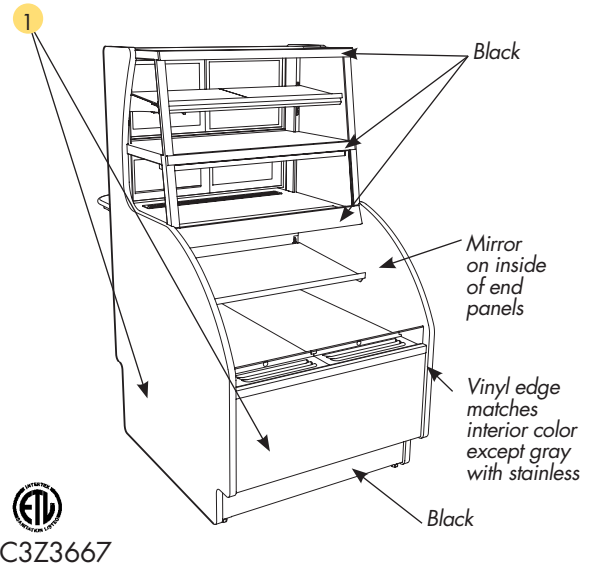

NOTE: Compressor air intake from rear and out front panel at toe kick. Front panel cannot be blocked.

| MODEL | C3Z3667 | C3Z4867 |
|------------|----------------------------|----------------------------|
| Dimensions | 36"L x 41 7/8"D x 67 1/2"H | 48"L x 41 7/8"D x 67 1/2"H |
| List \$ | \$16,819 | \$18,247 |

Dimensions shown are not exact. Refer to Factory Specification drawings for more detail.

| Product Specification | Standard (N/C) | Option(s) | List \$ |
|--|---|---|------------------------------------|
| Interior Color* | Black | Stainless Steel | \$2,090 |
| Exterior Color* 1 | Choice of Wilsonart® or Formica® non-premium laminates | Wilsonart® or Formica® premium laminates (as noted in laminate charts) Other manufacturer's laminates Stainless Steel | \$620 Call for quote \$1,320 |
| Upper/Middle Rear* | Clear glass sliding doors | Reflective glass sliding doors | \$260 |
| Base* | Levelers | Casters** | \$340 |
| Refrigeration* | Breeze™ self-contained w/ evaporator pan (rear air intake/ front air discharge at toe kick) | Pressure release valve (required for city of Chicago) - must be ordered with case | \$50 |
| Miscellaneous (Must be chosen when case is ordered) | | Rear door locks Second year parts & labor warranty (excludes compressor) | \$210 \$530 |
| Accessories (Can be purchased at any time. Refer to pages 76/77 for information) | | Display steps (2 1/2"H) (in lieu of shelf) Night curtain, pull-down, non-locking Removable wire security cover, locking | \$480 \$420 \$500 |

*Must choose one when placing order

**May increase height of case - refer to specification sheet

| MODEL | WEIGHT | Self-Contained Refrigeration/Dry | | |
|---------|--------|----------------------------------|-------|-----------|
| | | VOLTS | AMPS | NEMA PLUG |
| C3Z3667 | 910 | 120/1/60 | 16.52 | 5-20P |
| C3Z4867 | 1140 | 120/1/60 | 17.52 | 5-20P |

Freight Class: 110

NOTE: Freight rate subject to linear foot rule.

Based on operating conditions of 75°F and 55% relative humidity. Specifications and pricing subject to change without notice.

WASCIS®

Combination Non-Refrigerated Service Above Refrigerated Self-Service Case

Standard Features

- Breeze™ Refrigeration System (See page 1)
- Upper service display area
 - Fixed front glass
 - Non-refrigerated with 12"D glass shelf and 19 1/2"D deck
 - Clear glass rear sliding doors
- Lower self-service display area with open reach-in front and angled deck
 - Single display level consisting of bottom deck (21 7/8"D)
- Two full end panels with mirror interior (lower section)
- T-8 top light and shelf lights
- Four casters
- 6' power cord
- Integrated average product temperature of 41 °F
- ETL sanitation conforms to NSF 7
- 1 year parts and labor; 5 year compressor warranty

NOTE: Compressor air intake from rear and out front panel at toe kick. Front panel cannot be locked.

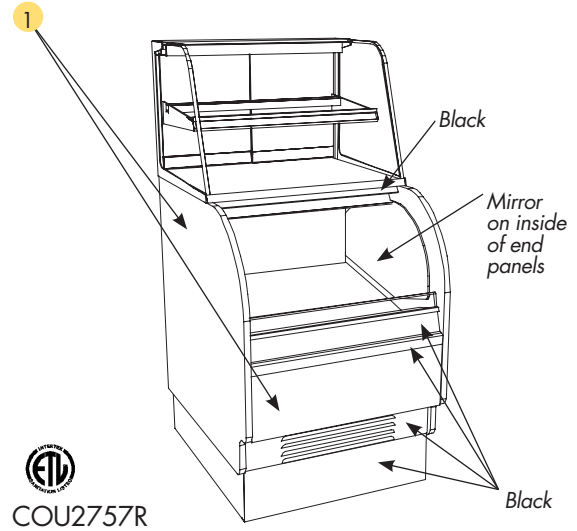

Quick-Ship
See page 10

| MODEL | COU2757R |
|------------|----------------------------|
| Dimensions | 28"L x 34 1/2"D x 56 7/8"H |
| List \$ | \$11,153 |

Dimensions shown are not exact. Refer to Factory Specification drawings for more detail.

| Product Specification | Standard (N/C) | Option(s) | List \$ |
|--|---|---|------------------------------------|
| Interior Color* | Black | Stainless Steel | \$2,090 |
| Exterior Color* 1 | Choice of Wilsonart® or Formica® non-premium laminates | Wilsonart® or Formica® premium laminates (as noted in laminate charts) Other manufacturer's laminates Stainless Steel | \$620 Call for quote \$1,320 |
| Upper Rear* | Clear glass sliding doors | Reflective glass sliding doors | \$260 |
| Refrigeration* | Breeze™ self-contained w/ evaporator pan (rear air intake/ front air discharge at toe kick) | Pressure release valve (required for city of Chicago) - must be ordered with case | \$50 |
| Miscellaneous (Must be chosen when case is ordered) | | Rear door lock (upper display area) Second year parts & labor warranty (excludes compressor) | \$210 \$530 |
| Accessories (Can be purchased at any time. Refer to pages 76/77 for information) | | Display steps (2"H) (in lieu of shelf) Night curtain, pull-down, non-locking Removable wire security cover, locking | \$480 \$420 \$500 |

*Must choose one when placing order

| Self-Contained Refrigeration/Dry | | | | |
|----------------------------------|--------|----------|------|-----------|
| MODEL | WEIGHT | VOLTS | AMPS | NEMA PLUG |
| COU2757R | 530 | 120/1/60 | 6.91 | 5-15P |

Freight Class: 110 NOTE: Freight rate subject to linear foot rule.

Based on operating conditions of 75°F and 55% relative humidity. Specifications and pricing subject to change without notice.

Refrigerated Service Case (Deli)

Standard Features

- Breeze™ Refrigeration System (See page 1)
- Two full end panels with mirror interior
- Curved single pane lift-up front glass
- Clear glass rear sliding doors
- Straight laminated upper front panel
- Painted lower front panel
- T-8 top, shelf and nose lights
- One lighted metal shelf
- 6' power cord
- Integrated average product temperature of 41°F
- ETL sanitation conforms to NSF 7
- 1 year parts and labor; 5 year compressor warranty

NOTE: Compressor air intake from rear and out front panel at toe kick. Front panel cannot be blocked.

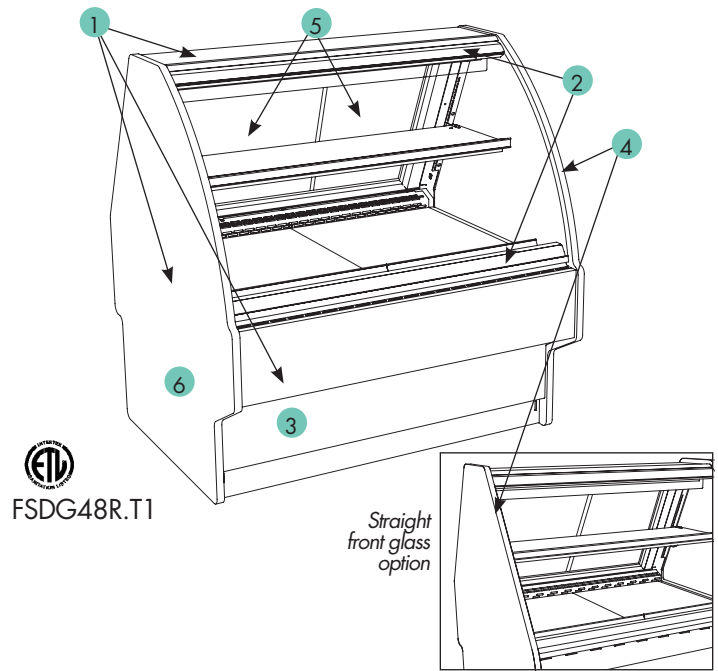

ETL
FSDG48R.T1

Straight front glass option

| MODEL | FSDG48R.T1 | FSDG72R.T1 | FSDG96R.T1 | FSDG144R.T1 |
|------------|--------------------|--------------------|---------------------|---------------------|
| Dimensions | 51"L x 43"D x 54"H | 75"L x 43"D x 54"H | 100"L x 43"D x 54"H | 148"L x 43"D x 54"H |
| List \$ | \$17,220 | \$19,179 | \$24,941 | \$32,530 |

Dimensions shown are not exact. Refer to Factory Specification drawings for more detail.

| Product Specification | Standard (N/C) | Option(s) | List \$ |
|--|--|--|---|
| Interior Color* | Black | White Stainless Steel | N/C \$1,980 |
| Exterior Color* 1 | Choice of Wilsonart® or Formica® non-premium laminates | Wilsonart® or Formica® premium laminates (as noted in laminate charts) Other manufacturer's laminates Stainless Steel Oak veneer with clear sealer Oak veneer stained (color match required) | \$620 Call for quote \$1,250 \$1,700 \$1,930 |
| Trim Color* 2 | Black | Silver | N/C |
| Lower Front Panel* 3 | Black | Stainless Steel | \$210 |
| Front Glass Style* 4 | Curved | Straight | N/C |
| Upper Rear* 5 | Clear glass sliding doors | Reflective glass sliding doors | \$260 |
| End Panel Style* 6 | Full with stainless mirror | Cutaway with glass Case to case glass end Deduct end panel (for case to case lineups) | \$1,580/end -\$100/end -\$240/end |
| Base* | Levelers | Casters (not available with remote refrigeration)** 6"H legs (increases height of case 6") | \$340 \$350 |
| Refrigeration* | Breeze™ self-contained w/ evaporator pan (rear air intake/ front air discharge over glass) | Remote (compressor supplied by others) Pressure release valve (required for city of Chicago) - must be ordered with case | Call for quote \$50 |
| Miscellaneous (Must be chosen when case is ordered) | | Rear door lock Front glass lock 3"H Display steps (N/A with shelf) Scale stand with appliance receptacle (requires separate electrical) Energy efficient fans Clean Sweep® automatic condenser coil cleaner Second year parts & labor warranty (excludes compressor) | \$210 \$210 \$580 \$360 \$280 \$990 \$530 |
| Accessories (Can be purchased at any time. Refer to pages 76/77 for information) | | Rear wrapping board, 8"D Price tag molding | \$450 \$130 |

*Must choose one when placing order

**May increase height of case - refer to specification sheet

| MODEL | WEIGHT | Self-Contained Refrigeration/Dry | | | Remote Refrigeration with Leads | | |
|-------------|--------|----------------------------------|-------|-----------|---------------------------------|------|-------|
| | | VOLTS | AMPS | NEMA PLUG | VOLTS | AMPS | BTUH |
| FSDG48R.T1 | 950 | 220/1/60* | 16.51 | 14-20P | 120/1/60 | 2.16 | 3,053 |
| FSDG72R.T1 | 1,150 | 220/1/60* | 15.78 | 14-20P | 120/1/60 | 4.5 | 3,217 |
| FSDG96R.T1 | 1,270 | 220/1/60* | 16.54 | 14-20P | 120/1/60 | 4.99 | 3,792 |
| FSDG144R.T1 | 2,150 | 220/1/60* | 20.1 | 14-30P | 120/1/60 | 7.25 | 7,888 |

Freight Class: 110 NOTE: Freight rate subject to linear foot rule. * Requires three wires plus ground.

Based on operating conditions of 75°F and 55% relative humidity. Specifications and pricing subject to change without notice.

Hot Service Case (Deli)

Standard Features

- Individually controlled stainless steel heated wells (dry heat)
 - FSDG48W.T1 - three full size & three one-third size 4"D pans
 - FSDG72W.T1 - five full size & five one-third size 4"D pans
 - FSDG96W.T1 - seven full size & seven one-third size 4"D pans
- Stainless Steel interior
- Two cutaway with glass end panels
- Curved single pane lift-up front glass
- Clear glass rear sliding doors
- Straight laminated upper front panel
- Painted lower front panel
- Header lights with shatter resistant bulbs
- Infrared overhead heat (individually controlled)
- Integrated average product temperature of 160°F
- UL Certified to NSF Standard 4
- 1 year parts and labor warranty

NOTE: Pans not supplied with case.

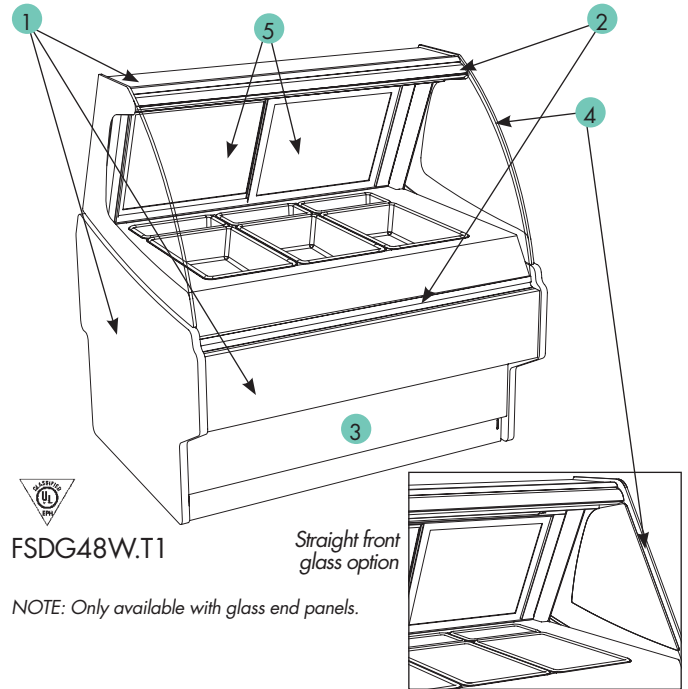

| MODEL | FSDG48W.T1 | FSDG72W.T1 | FSDG96W.T1 |
|------------|--------------------|--------------------|---------------------|
| Dimensions | 51"L x 43"D x 54"H | 75"L x 43"D x 54"H | 100"L x 43"D x 54"H |
| List \$ | \$17,131 | \$20,106 | \$26,986 |

Dimensions shown are not exact. Refer to Factory Specification drawings for more detail.

| Product Specification | Standard (N/C) | Options(s) | List \$ |
|---|--|--|------------------------------------|
| Exterior Color* ¹ | Choice of Wilsonart® or Formica® non-premium laminates | Wilsonart® or Formica® premium laminates (as noted in laminate charts) Other manufacturer's laminates Stainless Steel | \$620 Call for quote \$1,250 |
| Trim Color* ² | Black | Silver | N/C |
| Lower Front Panel* ³ | Black | Stainless Steel | \$210 |
| Front Glass Style* ⁴ | Curved | Straight | N/C |
| Upper Rear* ⁵ | Clear glass sliding doors | Reflective glass sliding doors | \$260 |
| Base* | Levelers | 6"H legs (increases height of case 6") | \$350 |
| Miscellaneous (Must be chosen when case is ordered) | | Rear door lock Front glass lock Scale stand with appliance receptacle (requires separate electrical) Second year parts & labor warranty | \$210 \$210 \$360 \$530 |
| Accessories (Can be purchased at any time. Refer to pages 76/77 for information) | | Rear wrapping board, 8"D Control knob guards | \$450 \$200 |

*Must choose one when placing order

| MODEL | WEIGHT | Heated | | | | | |
|------------|--------|------------------|-----------|-----|---------------------|--------------------|-----------|
| | | VOLTS ++ (60 Hz) | | | AMPS (Single Phase) | AMPS (Three Phase) | NEMA Plug |
| FSDG48W.T1 | 770 | Heated | Circuit 1 | 220 | 18.4 | 10.6 | Leads |
| FSDG72W.T1 | 800 | Heated | Circuit 1 | 220 | 30.7 | 17.7 | Leads |
| FSDG96W.T1 | 1,100 | Heated | Circuit 1 | 220 | 43 | 24.8 | Leads |

Freight Class: 110 NOTE: Freight rate subject to linear foot rule.

Based on operating conditions of 75°F and 55% relative humidity. Specifications and pricing subject to change without notice.

Refrigerated Service Case (Bakery)

Standard Features

- Breeze™ Refrigeration System (See page 1)
- Two full end panels with mirror interior
- Curved single pane lift-up front glass
- Clear glass rear sliding doors
- Two lighted glass shelves (12"D, 20"D)
- Straight laminated upper front panel
- Painted lower front panel
- T-8 top, shelf and nose lights
- 6' power cord
- Integrated average product temperature of 41°F
- ETL sanitation conforms to NSF 7
- 1 year parts and labor; 5 year compressor warranty

NOTE: Compressor air intake from rear and out front panel at toe kick. Front panel cannot be blocked.

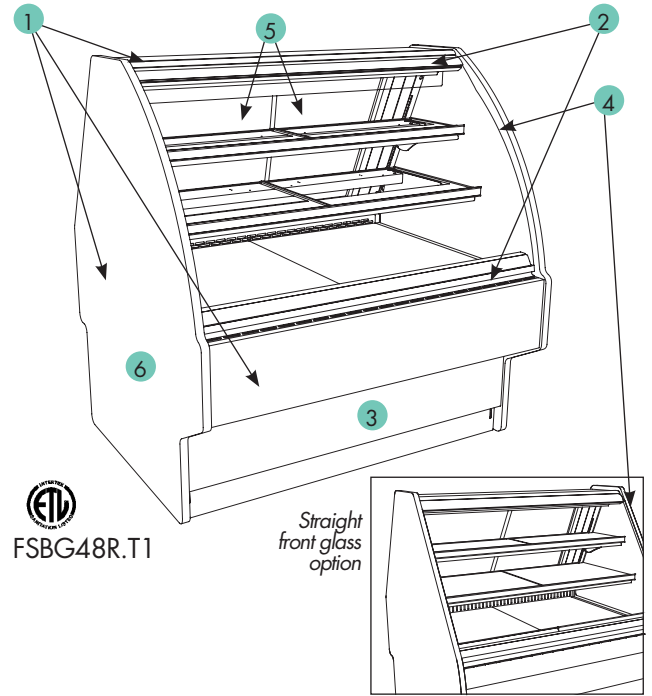

ETL
FSBG48R.T1

Straight front glass option

| MODEL | FSBG48R.T1 | FSBG72R.T1 |
|------------|--------------------|--------------------|
| Dimensions | 51"L x 43"D x 54"H | 75"L x 43"D x 54"H |
| List \$ | \$17,530 | \$19,364 |

Dimensions shown are not exact. Refer to Factory Specification drawings for more detail.

| Product Specification | Standard (N/C) | Option(s) | List \$ |
|--|--|--|--|
| Interior Color* | Black | White Stainless Steel | N/C \$1,980 |
| Exterior Color * 1 | Choice of Wilsonart® or Formica® non-premium laminates | Wilsonart® or Formica® premium laminates (as noted in laminate charts) Other manufacturer's laminates Stainless Steel Oak veneer with clear sealer Oak veneer stained (color match required) | \$620 Call for quote \$1,250 \$1,700 \$1,930 |
| Trim Color* 2 | Black | Silver | N/C |
| Lower Front Panel* 3 | Black | Stainless Steel | \$210 |
| Front Glass Style* 4 | Curved | Straight | N/C |
| Upper Rear* 5 | Clear glass sliding doors | Reflective glass sliding doors | \$260 |
| End Panel Style* 6 | Full with stainless mirror | Cutaway with glass Case to case glass end Deduct end panel (for case to case lineups) | \$1,580/end -\$100/end -\$240/end |
| Base* | Levelers | Casters (not available with remote refrigeration) ** 6"H legs (increases height of case 6") | \$340 \$350 |
| Refrigeration* | Breeze™ self-contained w/ evaporator pan (rear air intake/ front air discharge over glass) | Remote (compressor supplied by others) Pressure release valve (required for city of Chicago) must be ordered with case | Call for quote \$50 |
| Miscellaneous (Must be chosen when case is ordered) | | Rear door lock Front glass lock Scale stand with appliance receptacle (requires separate electrical) Energy efficient fans Clean Sweep® automatic condenser coil cleaner Second year parts & labor warranty (excludes compressor) | \$210 \$210 \$360 \$280 \$990 \$530 |
| Accessories (Can be purchased at any time. Refer to pages 76/77 for information) | | Rear wrapping board, 8"D Price tag molding | \$450 \$130 |

*Must choose one when placing order

**May increase height of case - refer to specification sheet

| MODEL | WEIGHT | Self-Contained Refrigeration/Dry | | | Remote Refrigeration with Leads | | |
|------------|--------|----------------------------------|-------|-----------|---------------------------------|------|-------|
| | | VOLTS | AMPS | NEMA PLUG | VOLTS | AMPS | BTUH |
| FSBG48R.T1 | 940 | 220/1/60* | 16.17 | 14-20P | 120/1/60 | 3.42 | 3,053 |
| FSBG72R.T1 | 1,130 | 220/1/60* | 16.5 | 14-20P | 120/1/60 | 5.22 | 3,217 |

Freight Class: 110 NOTE: Freight rate subject to linear foot rule. *Requires three wires plus ground.

Based on operating conditions of 75°F and 55% relative humidity. Specifications and pricing subject to change without notice.

Service Non-Refrigerated Case (Bakery)

Standard Features

- Two full end panels with mirror interior
- Curved single pane lift-up front glass
- Clear glass rear sliding doors
- Two non-lighted wire shelves
- Straight laminated upper front panel
- Painted lower front panel
- T-8 top, shelf and nose lights
- Front electrical access
- 12" power cord
- ETL sanitation conforms to NSF 2
- ETL Listed Certified to CAN/CSA 22.2
- 1 year parts and labor warranty

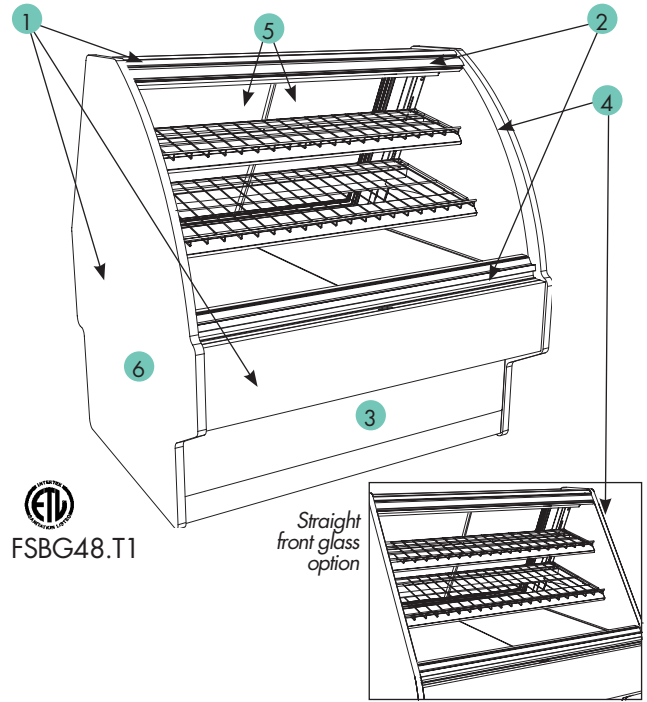

ETL
FSBG48.T1

Straight
front glass
option

| MODEL | FSBG48.T1 | FSBG72.T1 |
|------------|--------------------|--------------------|
| Dimensions | 51"L x 43"D x 54"H | 75"L x 43"D x 54"H |
| List \$ | \$11,234 | \$13,328 |

Dimensions shown are not exact. Refer to Factory Specification drawings for more detail.

| Product Specification | Standard (N/C) | Option(s) | List \$ |
|---|--|--|--|
| Interior Color* | Black | White Stainless Steel | N/C \$1,980 |
| Exterior Color * 1 | Choice of Wilsonart® or Formica® non-premium laminates | Wilsonart® or Formica® premium laminates (as noted in laminate charts) Other manufacturer's laminates Stainless Steel Oak veneer with clear sealer Oak veneer stained (color match required) | \$620 Call for quote \$1,250 \$1,700 \$1,930 |
| Trim Color* 2 | Black | Silver | N/C |
| Lower Front Panel* 3 | Black | Stainless Steel | \$210 |
| Front Glass Style* 4 | Curved | Straight | N/C |
| Upper Rear* 5 | Clear glass sliding doors | Reflective glass sliding doors | \$260 |
| End Panel Style* 6 | Full with stainless mirror | Cutaway with glass Case to case glass end Deduct end panel (for case to case lineups) | \$1,580/end -\$100/end -\$240/end |
| Shelving | Wire shelves | Clear glass, non-lighted shelves | \$290 |
| Base* | Levelers | Casters** 6"H legs (increases height of case 6") | \$340 \$350 |
| Miscellaneous (Must be chosen when case is ordered) | | Rear door lock Front glass lock Scale stand with appliance receptacle (requires separate electrical) Second year parts & labor warranty | \$210 \$210 \$360 \$530 |
| Accessories (Can be purchased at any time. Refer to pages 76/77 for information) | | Rear wrapping board, 8"D Price tag molding | \$450 \$130 |

*Must choose one when placing order

**May increase height of case - refer to specification sheet

| MODEL | WEIGHT | Self-Contained Refrigeration/Dry | | |
|-----------|--------|----------------------------------|------|-----------|
| | | VOLTS | AMPS | NEMA PLUG |
| FSBG48.T1 | 750 | 120/1/60 | 1.15 | 5-15P |
| FSBG72.T1 | 900 | 120/1/60 | 2.37 | 5-15P |

Freight Class: 110 NOTE: Freight rate subject to linear foot rule.

Based on operating conditions of 75°F and 55% relative humidity. Specifications and pricing subject to change without notice.

Combination Cold Service Above Cold Self-Service Case - 13" Short Dome

Standard Features

- Breeze™ Refrigeration System (See page 1)
- Two cutaway with glass end panels
- Curved single pane lift-up front glass
- T-8 top, shelf and nose lights
- Adjustable/removable metal shelves (lower display)
- Integrated average product temperature of 41°F
- ETL sanitation conforms to NSF 7
- ETL Listed Certified to CAN/CSA 22.2
- 1 year parts and labor; 5 year compressor warranty

NOTE: Compressor air intake from rear and out front panel at toe kick. Front panel cannot be blocked.

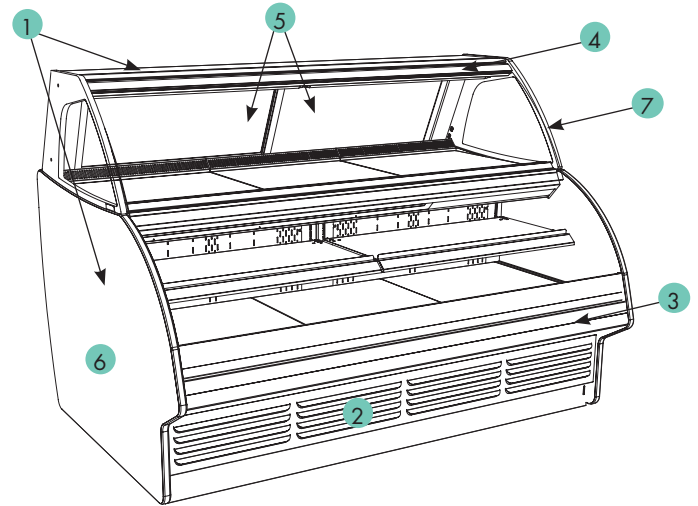

FSGURLR7254

| MODEL | FSGURLR4854 | FSGURLR7254 | FSGURLR9654 |
|------------|--------------------|--------------------|---------------------|
| Dimensions | 51"L x 53"D x 54"H | 75"L x 53"D x 54"H | 100"L x 53"D x 54"H |
| List \$ | \$26,737 | \$32,917 | \$34,977 |

Dimensions shown are not exact. Refer to Factory Specification drawings for more detail.

| Product Specification | Standard (N/C) | Options(s) | List \$ |
|--|---|--|------------------------------------|
| Interior Color* | Black | White Stainless Steel | N/C \$1,980 |
| Exterior Color* ¹ | Choice of Wilsonart® or Formica® non-premium laminates | Wilsonart® or Formica® premium laminates (as noted in laminate charts) Other manufacturer's laminates Stainless Steel | \$620 Call for quote \$1,250 |
| Lower Front Panel* ² | Black | Stainless Steel | \$210 |
| Upper Front Panel* ³ | Black | Silver Painted (specify color) | N/C N/C |
| Trim* ⁴ | Black | Silver | N/C |
| Front Glass Style ⁷ | Curved | Straight | N/C |
| Upper Rear ⁵ | Clear glass sliding doors | Reflective glass sliding doors | \$260 |
| Rear Storage* | Dry storage with sliding solid doors | Refrigerated storage with sliding solid doors | \$2,000 |
| End Panel Style* ⁶ | Cutaway with glass | Case to case glass end Deduct end panel (for case to case lineups) | -\$100/end -\$240/end |
| Base* | Levelers | Casters (not available with remote refrigeration)** | \$340 |
| Refrigeration* | Breeze™ self-contained blower coil system with electrical leads | Remote (compressor supplied by others) Pressure release valve (required for city of Chicago) - must be ordered with case | Call for quote \$50 |
| Miscellaneous (Must be chosen when case is ordered) | | Scale stand with appliance receptacle (requires separate electrical) Energy efficient fans Clean Sweep® automatic condenser coil cleaner Second year parts & labor warranty (excludes compressor) | \$360 \$280 \$990 \$530 |
| Accessories (Can be purchased at any time. Refer to pages 76/77 for information) | | Rear wrapping board, 8"D Price tag molding | \$450 \$130 |

*Must choose one when placing order

**May increase height of case - refer to specification sheet

| MODEL | WEIGHT | Self-Contained Refrigeration/Dry | | | Remote Refrigeration with Leads | | |
|-------------|--------|----------------------------------|-------|-----------|---------------------------------|------|-------|
| | | VOLTS | AMPS | NEMA PLUG | VOLTS | AMPS | BTUH |
| FSGURLR4854 | 1,500 | 120/1/60 | 18.85 | 5-30P | 120/1/60 | 3.67 | 4,502 |
| FSGURLR7254 | 1,800 | 220/1/60* | 15.85 | 14-20P | 120/1/60 | 2.12 | 6,116 |
| FSGURLR9654 | 2,100 | 220/1/60* | 17.15 | 14-30P | 120/1/60 | 6.32 | 7,100 |

Freight Class: 110 NOTE: Freight rate subject to linear foot rule.

*Requires three wires plus ground.

Based on operating conditions of 75°F and 55% relative humidity. Specifications and pricing subject to change without notice.

Combination Cold Service Above Cold Self-Service Case - 16" Tall Dome

Standard Features

- Breeze™ Refrigeration System (See page 1)
- Two cutaway with glass end panels
- Curved single pane lift-up front glass
- T-8 top, shelf and nose lights
- Adjustable/removable metal shelves (lower display area)
- Integrated average product temperature of 41°F
- ETL sanitation conforms to NSF 7
- ETL Listed Certified to CAN/CSA 22.2
- 1 year parts and labor; 5 year compressor warranty

NOTE: Compressor air intake from rear and out front panel at toe kick. Front panel cannot be blocked.

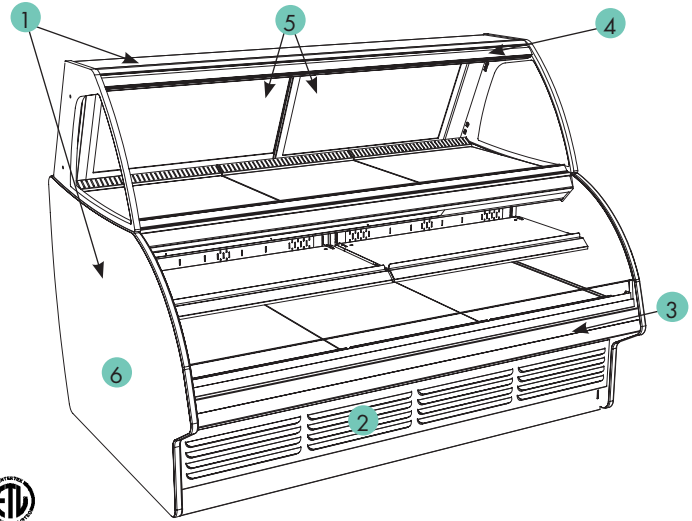

FSGURLR7257

| MODEL | FSGURLR4857 | FSGURLR7257 | FSGURLR9657 |
|------------|--------------------|--------------------|---------------------|
| Dimensions | 51"L x 53"D x 57"H | 75"L x 53"D x 57"H | 100"L x 53"D x 57"H |
| List \$ | \$27,355 | \$33,535 | \$35,595 |

Dimensions shown are not exact. Refer to Factory Specification drawings for more detail.

| Product Specification | Standard (N/C) | Options(s) | List \$ |
|---|---|--|------------------------------------|
| Interior Color* | Black | White Stainless Steel | N/C \$1,980 |
| Exterior Color* ¹ | Choice of Wilsonart® or Formica® non-premium laminates | Wilsonart® or Formica® premium laminates (as noted in laminate charts) Other manufacturer's laminates Stainless Steel | \$620 Call for quote \$1,250 |
| Lower Front Panel* ² | Black | White Stainless Steel Painted (specify colors) | N/C \$210 N/C |
| Upper Front Panel* ³ | Black | Silver Painted (specify colors) | N/C N/C |
| Trim* ⁴ | Black | Silver | N/C |
| Front Glass Style | Curved | Straight | N/C |
| Upper Rear ⁵ | Clear glass sliding doors | Reflective glass sliding doors | \$260 |
| Rear Storage* | Dry storage with sliding solid doors | Refrigerated storage with sliding solid doors | \$2,000 |
| End panel Style* ⁶ | Cutaway with glass | Case to case glass end Deduct end panel (for case to case lineups) | -\$100/end -\$240/end |
| Base* | Levelers | Casters (not available with remote refrigeration)** | \$340 |
| Refrigeration* | Breeze™ self-contained blower coil system with electrical leads | Remote (compressor supplied by others) Pressure release valve (required for city of Chicago) - must be ordered with case | Call for quote \$50 |
| Miscellaneous (Must be chosen when case is ordered) | | Scale stand with appliance receptacle (requires separate electrical) Energy efficient fans Clean Sweep® automatic condenser coil cleaner Second year parts & labor warranty (excludes compressor) | \$360 \$280 \$990 \$530 |
| Accessories (Can be purchased at any time. Refer to pages 76/77 for information) | | Lighted upper metal shelf, 10"D Rear wrapping board, 8"D Price tag molding | \$750 \$450 \$130 |

*Must choose one when placing order

**May increase height of case - refer to specification sheet

| MODEL | WEIGHT | Self-Contained Refrigeration/Dry | | | Remote Refrigeration with Leads | | |
|-------------|--------|----------------------------------|-------|-----------|---------------------------------|------|-------|
| | | VOLTS | AMPS | NEMA PLUG | VOLTS | AMPS | BTUH |
| FSGURLR4857 | 1,250 | 120/1/60 | 21.97 | 5-30P | 120/1/60 | 3.67 | 4,502 |
| FSGURLR7257 | 1,350 | 120/1/60 | 16.18 | 14-20P | 120/1/60 | 4.01 | 6,116 |
| FSGURLR9657 | 2,200 | 120/1/60 | 18.92 | 14-30P | 120/1/60 | 6.8 | 7,100 |

Freight Class: 110 NOTE: Freight rate subject to linear foot rule.

*Requires three wires plus ground.

Based on operating conditions of 75°F and 55% relative humidity. Specifications and pricing subject to change without notice.

Combination Hot Service Above Refrigerated Air Screen Case

Standard Features

- Breeze™ Refrigeration System (See page 1)
- Two cutaway with glass end panels
- Straight laminated upper front panel
- Painted lower front panel
- Refrigerated lower display area
 - T-8 top and nose lights
 - Single display level (21 3/4"D)
 - Integrated average product temperature of 41°F
- Hot service display area
 - Individually controlled stainless steel heat wells (dry heat)
 - FSGUWLR48.T1 - three full size & three one-third size pans
 - FSGUWLR72.T1 - five full size & five one-third size pans
 - FSGUWLR96.T1 - seven full size & seven one-third size pans
 - Curved single pane lift-up front glass
 - Infrared overhead heat (individually controlled)
 - Header lights with shatter resistant bulbs
 - Integrated average product temperature of 160°F
- UL Certified to NSF Standard 4
- 1 year parts and labor; 5 year compressor warranty

NOTE: Compressor air intake from rear and out front panel at toe kick. Front panel cannot be blocked.

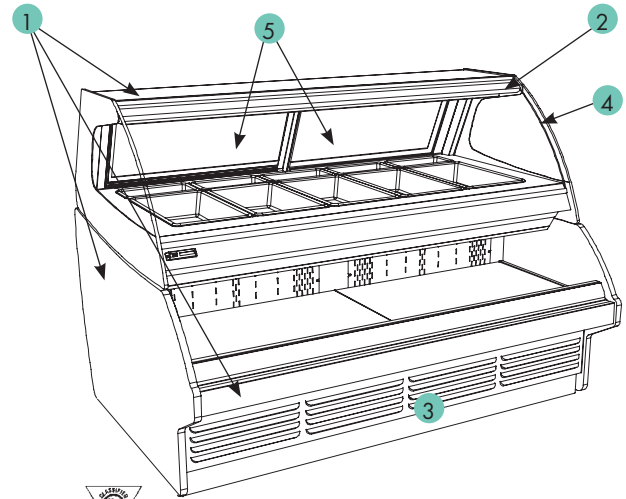

FSGUWLR72.T1

NOTE: Only available with cutaway glass end panels.

NOTE: Pans not supplied with case.

| MODEL | FSGUWLR48.T1 | FSGUWLR72.T1 | FSGUWLR96.T1 |
|------------|--------------------|--------------------|---------------------|
| Dimensions | 51"L x 53"D x 54"H | 75"L x 53"D x 54"H | 100"L x 53"D x 54"H |
| List \$ | \$26,444 | \$32,178 | \$36,184 |

Dimensions shown are not exact. Refer to Factory Specification drawings for more detail.

| Product Specification | Standard (N/C) | Option(s) | List \$ |
|--|---|--|--|
| Interior Color* (Lower display area) | Black | White Stainless Steel | N/C \$1,980 |
| Exterior Color* ¹ | Choice of Wilsonart® or Formica® non-premium laminates | Wilsonart® or Formica® premium laminates (as noted in laminate charts) Other manufacturer's laminates Stainless Steel Oak veneer with clear sealer Oak veneer stained (color match required) | \$620 Call for quote \$1,250 \$1,700 \$1,930 |
| Trim Color* ² | Black | Silver | N/C |
| Lower Front Panel* ³ | Black | Stainless Steel | \$210 |
| Front Glass Style* ⁴ | Curved | Straight | N/C |
| Upper Rear* ⁵ | Clear glass sliding doors | Reflective glass sliding doors | \$260 |
| Base* | Levelers | 6"H legs (increases height of case 6") | \$350 |
| Refrigeration* | Breeze™ self-contained w/ evaporator pan (rear air intake/ front air discharge at toe kick) | Remote (compressor supplied by others) Pressure release valve (required for city of Chicago) - must be ordered with case | Call for quote \$50 |
| Miscellaneous (Must be chosen when case is ordered) | | Rear door lock Front glass lock Scale stand with appliance receptacle (requires separate electrical) Energy efficient fans Clean Sweep® automatic condenser coil cleaner Second year parts & labor warranty (excludes compressor) | \$210 \$210 \$360 \$280 \$990 \$530 |
| Accessories (Can be purchased at any time. Refer to pages 76/77 for information) | | Removable wire security cover, locking Night curtain, pull down, non-locking Rear wrapping board, 8"D Control knob guards Price tag molding | \$500 \$420 \$450 \$200 \$130 |

*Must choose one when placing order

| MODEL | WEIGHT | Refrigerated/Heated | | | | NEMA PLUG | BTUH |
|--------------|--------|--|------------------------|-----------------------|--|-----------|-------|
| | | VOLTS++ (60 Hz) | AMPS*** (Single Phase) | AMPS*** (Three Phase) | | | |
| FSGUWLR48.T1 | 1,020 | | | | | Leads | 2,489 |
| FSGUWLR72.T1 | 1,200 | Contact factory for technical electrical information. | | | | Leads | 3,118 |
| FSGUWLR96.T1 | 1,900 | | | | | Leads | 3,840 |

Freight Class: 110 NOTE: Freight rate subject to linear foot rule.

Based on operating conditions of 75°F and 55% relative humidity. Specifications and pricing subject to change without notice.

Combination Hot Service Above Refrigerated Air Screen Case

Standard Features

- Breeze™ Refrigeration System (See page 1)
- Two cutaway with glass end panels
- Levelers
- Refrigerated lower display area
 - T-8 top light and nose lights
 - Single display level
 - Integrated average product temperature of 41°F
- Hot service display area
 - Individually controlled stainless steel heat wells (dry heat)
 - FSGUWLR4854 - three full size pans (not included)
 - FSGUWLR7254 - five full size pans (not included)
 - FSGUWLR9654 - seven full size pans (not included)
 - Curved single pane lift-up front glass
 - Infrared overhead heat (individually controlled)
 - Header lights with shatter resistant bulbs
 - Integrated average product temperature of 160°F
- UL Certified to NSF Standard 4
- 1 year parts and labor; 5 year compressor warranty

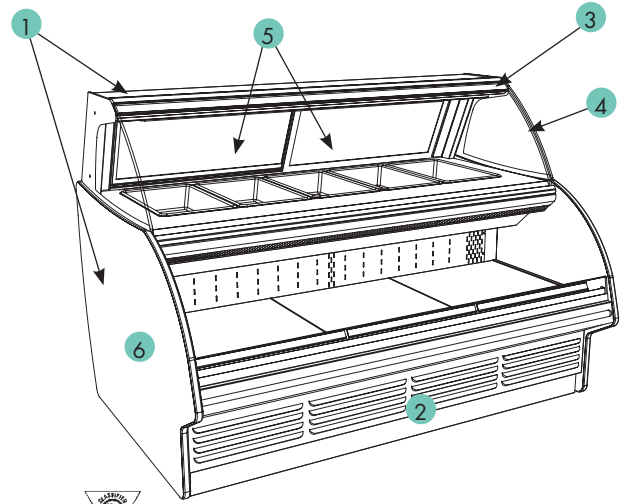

FSGUWLR7254

NOTE: Pans not supplied with case.

NOTE: Compressor air intake from rear and out front panel at toe kick. Front panel cannot be blocked.

| MODEL | FSGUWLR4854 | FSGUWLR7254 | FSGUWLR9654 |
|------------|--------------------|--------------------|---------------------|
| Dimensions | 51"L x 53"D x 54"H | 75"L x 53"D x 54"H | 100"L x 53"D x 54"H |
| List \$ | \$32,917 | \$41,157 | \$49,397 |

Dimensions shown are not exact. Refer to Factory Specification drawings for more detail.

| Product Specification | Standard (N/C) | Option(s) | List \$ |
|--|---|--|--|
| Interior Color* (Lower display area) | Black | White Stainless Steel | N/C \$1,980 |
| Exterior Color* ¹ | Choice of Wilsonart® or Formica® non-premium laminates | Wilsonart® or Formica® premium laminates (as noted in laminate charts) Other manufacturer's laminates Stainless Steel | \$620 Call for quote \$1,250 |
| Lower Front Panel* ² | Black | Stainless Steel | \$210 |
| Upper Front Panel | Black | Silver | N/C |
| Trim Color* ³ | Black | Silver | N/C |
| Front Glass Style* ⁴ | Curved | Straight | N/C |
| Upper Rear* ⁵ | Clear glass sliding doors | Reflective glass sliding doors | \$260 |
| End Panel Style* ⁶ | Cutaway with glass | Case to case glass end Deduct end panel (for case to case lineups) | -\$100/end -\$240/end |
| Refrigeration* | Breeze™ self-contained w/ evaporator pan (rear air intake/ front air discharge at toe kick) | Remote (compressor supplied by others) Pressure release valve (required for city of Chicago) - must be ordered with case | Call for quote \$50 |
| Miscellaneous (Must be chosen when case is ordered) | | Rear door lock Front glass lock Scale stand with appliance receptacle (requires separate electrical) Energy efficient fans Clean Sweep® automatic condenser coil cleaner Second year parts & labor warranty (excludes compressor) | \$210 \$210 \$360 \$280 \$990 \$530 |
| Accessories (Can be purchased at any time. Refer to pages 76/77 for information) | | Rear wrapping board, 8"D Control knob guards Price tag molding | \$450 \$200 \$130 |

*Must choose one when placing order

| MODEL | WEIGHT | Self-Contained Refrigeration/Dry | | | Remote Refrigeration with Leads | | |
|-------------|--------|----------------------------------|-------|-----------|---------------------------------|-------|-------|
| | | VOLTS | AMPS | NEMA PLUG | VOLTS | AMPS | BTUH |
| FSGUWLR4854 | 1,400 | 220/1/60* | 32.86 | Leads | 220/1/60* | 18.98 | 2,033 |
| FSGUWLR7254 | 1,700 | 220/1/60* | 46.44 | Leads | 220/1/60* | 12.76 | 2,686 |
| FSGUWLR9654 | 2,000 | 220/1/60* | 61.67 | Leads | 220/1/60* | 29.82 | 4,132 |

Freight Class: 110 NOTE: Freight rate subject to linear foot rule.

*Requires three wires plus ground.

Based on operating conditions of 75°F and 55% relative humidity. Specifications and pricing subject to change without notice.

Combination Hot Service and Self-Service Above Refrigerated Air Screen Case

Standard Features

- Breeze™ Refrigeration System (See page 1)
- Two cutaway with glass end panels
- Straight laminated upper front panel
- Painted lower front panel
- Refrigerated lower display area
 - T-8 top light and nose light
 - Single display level (21 3/4"D)
 - Integrated average product temperature of 41°F
- Hot service display area
 - Individually controlled stainless steel heat wells (dry heat)
 - FSSUWLR72.T1 - three full size & three one-third size pans, and self-service display area
 - FSSUWLR96.T1 - five full size & five one-third size pans, and self-service display area
 - Curved single pane lift-up front glass (service side)
 - Header light with shatter resistant bulbs
 - Infrared overhead heat (individually controlled)
 - Integrated average product temperature of 160°F
- UL Certified to NSF Standard 4
- 1 year parts and labor; 5 year compressor warranty

NOTE: Compressor air intake from rear and out front panel at toe kick. Front panel cannot be blocked.

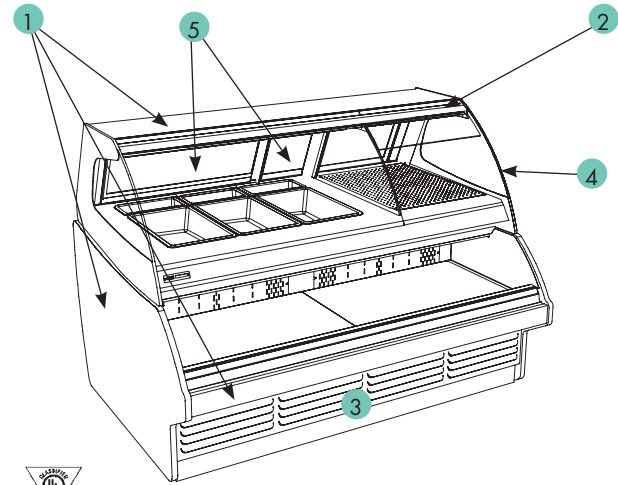

FSSUWLR72.T1

NOTE: Only available with cutaway glass end panels.

NOTE: Pans not supplied with case.

| MODEL | FSSUWLR72.T1 | FSSUWLR96.T1 |
|------------|--------------------|---------------------|
| Dimensions | 75"L x 53"D x 54"H | 100"L x 53"D x 54"H |
| List \$ | \$34,279 | \$38,758 |

Dimensions shown are not exact. Refer to Factory Specification drawings for more detail.

| Product Specification | Standard (N/C) | Options(s) | List \$ |
|--|---|--|--|
| Interior Color* (Lower display area) | Black | White Stainless Steel | N/C \$1,980 |
| Exterior Color* ¹ | Choice of Wilsonart® or Formica® non-premium laminates | Wilsonart® or Formica® premium laminates (as noted in laminate charts) Other manufacturer's laminates Stainless Steel Oak veneer with clear sealer Oak veneer stained (color match required) | \$620 Call for quote \$1,250 \$1,700 \$1,930 |
| Trim Color* ² | Black | Silver | N/C |
| Lower Front Panel* ³ | Black | Stainless Steel | \$210 |
| Front Glass Style* ⁴ | Curved | Straight | N/C |
| Upper Rear* ⁵ | Clear glass sliding doors | Reflective glass sliding doors | \$260 |
| Base* | Levelers | 6"H legs (increases height of case 6") | \$350 |
| Refrigeration* | Breeze™ self-contained w/ evaporator pan (rear air intake/ front air discharge at toe kick) | Remote (compressor supplied by others) Pressure release valve (required for city of Chicago) - must be ordered with case | Call for quote \$50 |
| Miscellaneous (Must be chosen when case is ordered) | | Rear door lock Front glass lock Scale stand with appliance receptacle (requires separate electrical) Energy efficient fans Clean Sweep® automatic condenser coil cleaner Second year parts & labor warranty (excludes compressor) | \$210 \$210 \$360 \$280 \$990 \$530 |
| Accessories (Can be purchased at any time. Refer to pages 76/77 for information) | | Removable wire security cover, locking Night curtain, pull down, non-locking Rear wrapping board, 8"D Control knob guards Price tag molding | \$500 \$420 \$450 \$200 \$130 |

*Must choose one when placing order

| MODEL | WEIGHT | Refrigerated/Heated | | | | |
|--------------|--------|--|------------------------|-----------------------|-----------|-------|
| | | VOLTS++ (60 Hz) | AMPS*** (Single Phase) | AMPS*** (Three Phase) | NEMA PLUG | BTUH |
| FSSUWLR72.T1 | 1,350 | Contact factory for technical electrical information. | | | Leads | 3,118 |
| FSSUWLR96.T1 | 1,550 | | | | Leads | 3,840 |

Freight Class: 110 NOTE: Freight rate subject to linear foot rule.

Based on operating conditions of 75°F and 55% relative humidity. Specifications and pricing subject to change without notice.

Combination Preparation/Refrigerated Air Screen Case (with Rear Storage)

Standard Features

- Breeze™ Refrigeration System (See page 1)
- Two full end panels with mirror interior
- Straight laminated upper front panel
- Painted lower front panel
- Refrigerated lower display area
 - T-8 top light and nose light
 - Adjustable/removable non-lighted metal shelf (15 1/2"D)
 - Bottom display deck (21 3/4"D)
- Preparation Area
 - Adjustable condiment pan rail
 - Sanalite® work surface (16"D)
 - Non-refrigerated rear storage (with one stainless steel shelf) without doors
 - Three sided glass sneeze guard
- 6' power cord
- Integrated average product temperature of 41°F
- ETL sanitation conforms to NSF 7
- ETL Listed Certification to CAN/CSA 22.2
- 1 year parts and labor; 5 year compressor warranty

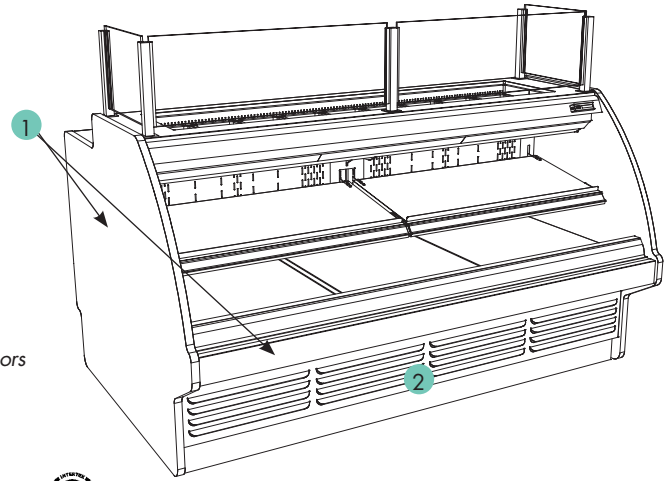

FSP7242R.T1

Note: Pans not supplied with case.

NOTE: Compressor air intake from rear and out front panel at toe kick. Front panel cannot be blocked.

| MODEL | FSP4842R.T1 | FSP7242R.T1 | FSP9642R.T1 (Remote only) |
|------------|--------------------|--------------------|---------------------------|
| Dimensions | 51"L x 51"D x 43"H | 75"L x 51"D x 43"H | 100"L x 51"D x 43"H |
| List \$ | \$16,715 | \$18,673 | \$18,505 |

Dimensions shown are not exact. Refer to Factory Specification drawings for more detail.

| Product Specification | Standard (N/C) | Options(s) | List \$ |
|--|--|--|--|
| Interior Color* | Black | White Stainless Steel | N/C \$1,980 |
| Exterior Color* 1 | Choice of Wilsonart® or Formica® non-premium laminates | Wilsonart® or Formica® premium laminates (as noted in laminate charts) Other manufacturer's laminates Stainless Steel Oak veneer with clear sealer Oak veneer stained (color match required) | \$620 Call for quote \$1,250 \$1,700 \$1,930 |
| Lower Front Panel* 2 | Black | Stainless Steel | \$210 |
| Sneeze Guard Posts* | Black | Silver | N/C |
| Rear Storage* | Non-refrigerated without doors (with one shelf) | Non-refrigerated with doors (with one shelf) Refrigerated with insulated doors (with one shelf) | \$370 \$5,460 |
| Rear Work Surface* | White Sanalite® | Stainless Steel | \$210 |
| Base* | Levelers | Casters (not available with remote refrigeration)** 6"H legs (increases height of case 6") | \$340 \$350 |
| Refrigeration* | Breeze™ self-contained w/ evaporator pan (rear air intake/ front air discharge at toe kick) (Not available on model FSP9642R.T1) | Remote (compressor supplied by others) (standard FSP9642R.T1) Pressure release valve (required for city of Chicago) - must be ordered with case | Call for quote \$50 |
| Miscellaneous (Must be chosen when case is ordered) | | Energy efficient fans Clean Sweep® automatic condenser coil cleaner Second year parts & labor warranty (excludes compressor) | \$280 \$990 \$530 |
| Accessories (Can be purchased at any time. Refer to pages 76/77 for information) | | Night curtain, pull down, non-locking Removable wire security cover, locking Price tag molding Additional non-lighted metal shelf | \$420 \$500 \$130 \$890 |

*Must choose one when placing order

**May increase height of case - refer to specification sheet

| MODEL | WEIGHT | Self-Contained Refrigeration/Dry | | | Remote Refrigeration with Leads | | |
|-------------|--------|----------------------------------|-------|-----------|---------------------------------|------|-------|
| | | VOLTS | AMPS | NEMA PLUG | VOLTS | AMPS | BTUH |
| FSP4842R.T1 | 950 | 120/1/60 | 22.79 | 5-30P | 120/1/60 | 3.29 | 3,870 |
| FSP7242R.T1 | 1,320 | 220/1/60* | 17.49 | 14-20P | 120/1/60 | 3.93 | 5,805 |
| FSP9642R.T1 | 1,900 | N/A | N/A | N/A | 120/1/60 | 4.53 | 7,764 |

Freight Class: 110 NOTE: Freight rate subject to linear foot rule.

*Requires three wires plus ground.

Based on operating conditions of 75°F and 55% relative humidity. Specifications and pricing subject to change without notice.

Combination Preparation/Refrigerated Air Screen Case (without Rear Storage)

Standard Features

- Breeze™ Refrigeration System (See page 1)
- Two full end panels with mirror interior
- Straight laminated upper front panel
- Painted lower front panel
- Refrigerated lower display area
 - T-8 top light and nose light
 - Adjustable/removable non-lighted metal shelf (15 3/4"D)
 - Bottom display deck
- Preparation Area
 - Adjustable condiment pan rails
 - Sanalite® work surface (7 1/2"D)
 - Sanalite® removable flip-up ledge (7 1/2"D)
 - Three sided glass sneeze guard
- 6' power cord
- Integrated average product temperature of 41°F
- ETL sanitation conforms to NSF 7
- ETL Listed Certified to CAN/CSA 22.2
- 1 year parts and labor; 5 year compressor warranty

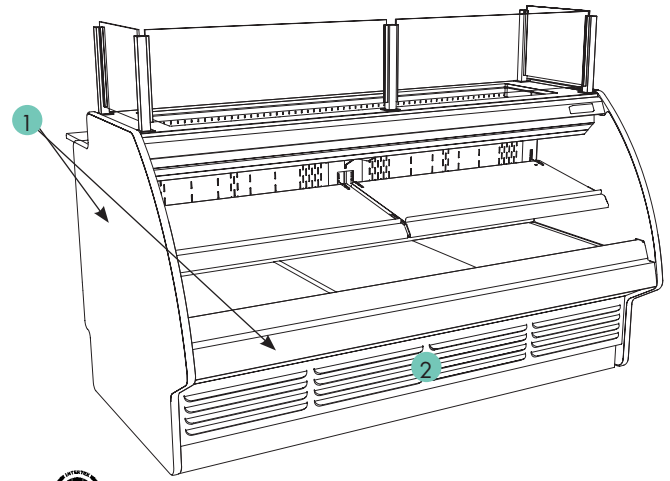

FSP72

Note: Pans not supplied with case.

NOTE: Compressor air intake from rear and out front panel at toe kick. Front panel cannot be blocked.

| MODEL | FSP48 | FSP72 | FSP96 |
|------------|--------------------|--------------------|---------------------|
| Dimensions | 51"L x 42"D x 43"H | 75"L x 42"D x 43"H | 100"L x 42"D x 43"H |
| List \$ | \$16,715 | \$18,673 | \$20,771 |

Dimensions shown are not exact. Refer to Factory Specification drawings for more detail.

| Product Specification | Standard (N/C) | Options(s) | List \$ |
|---|--|--|--|
| Interior Color* | Black | White Stainless Steel | N/C \$1,980 |
| Exterior Color* ¹ | Choice of Wilsonart® or Formica® non-premium laminates | Wilsonart® or Formica® premium laminates (as noted in laminate charts) Other manufacturer's laminates Stainless Steel Oak veneer with clear sealer Oak veneer stained (color match required) | \$620 Call for quote \$1,250 \$1,700 \$1,930 |
| Lower Front Panel* ² | Black | Stainless Steel | \$210 |
| Sneeze Guard Posts | Black | Silver | N/C |
| Rear Work Surface* | White Sanalite® | Stainless Steel | \$210 |
| Base* | Levelers | Casters (not available with remote refrigeration)** 6"H legs (increases height of case 6") | \$340 \$350 |
| Refrigeration* | Breeze™ self-contained w/ evaporator pan | Remote (compressor supplied by others) Pressure release valve (required for city of Chicago) - must be ordered with case | Call for quote \$50 |
| Miscellaneous (Must be chosen when case is ordered) | | Energy efficient fans Clean Sweep® automatic condenser coil cleaner Second year parts & labor warranty (excludes compressor) | \$280 \$990 \$530 |
| Accessories (Can be purchased at any time. Refer to pages 76/77 for information) | | Night curtain, pull down, non-locking Removable wire security cover, locking Price tag molding Additional non-lighted metal shelf | \$420 \$500 \$130 \$890 |

*Must choose one when placing order

**May increase height of case - refer to specification sheet

| MODEL | WEIGHT | Self-Contained Refrigeration/Dry | | | Remote Refrigeration with Leads | | |
|-------|--------|----------------------------------|-------|-----------|---------------------------------|------|--------|
| | | VOLTS | AMPS | NEMA PLUG | VOLTS | AMPS | BTUH |
| FSP48 | 950 | 120/1/60 | 20.74 | L5-30P | 120/1/60 | 1.44 | N/A |
| FSP72 | 1,550 | 220/1/60* | 14.37 | L14-20P | 120/1/60 | 2.26 | 6,378 |
| FSP96 | 2,000 | 220/1/60* | 16.1 | L14-20P | 120/1/60 | 3.27 | 10,517 |

Freight Class: 110 NOTE: Freight rate subject to linear foot rule.

*Requires three wires plus ground.

Based on operating conditions of 75°F and 55% relative humidity. Specifications and pricing subject to change without notice.

Open Lower Refrigerated Work Counter Case

Standard Features

- Breeze™ Refrigeration System (See page 1)
- Two full end panels with mirror interior
- Adjustable/removable lighted metal shelf
- 6' power cord
- Integrated average product temperature of 41°F
- ETL sanitation conforms to NSF 7
- ETL Listed Certified to CAN/CSA 22.2
- 1 year parts and labor; 5 year compressor warranty

NOTE: Compressor air intake from rear and out front panel at toe kick. Front panel cannot be blocked.

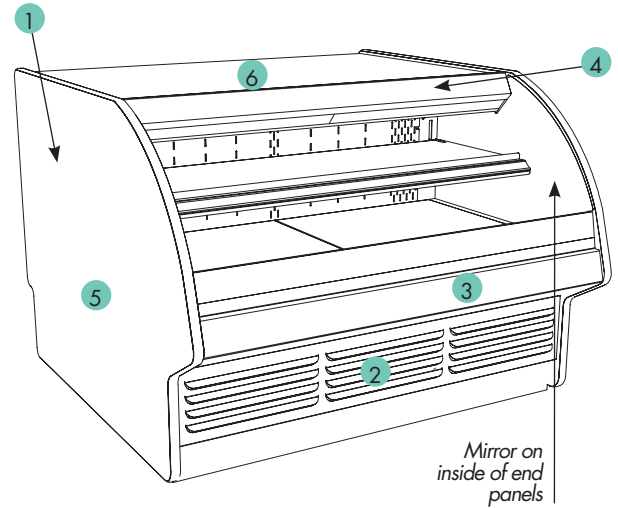

FSO4837R

| MODEL | FSO4837R | FSO7237R |
|------------|--------------------|--------------------|
| Dimensions | 51"L x 51"D x 37"H | 75"L x 51"D x 37"H |
| List \$ | \$16,457 | \$20,165 |

Dimensions shown are not exact. Refer to Factory Specification drawings for more detail.

| Product Specification | Standard (N/C) | Options(s) | List \$ |
|--|---|--|------------------------------------|
| Interior Color* | Black | White Stainless Steel | N/C \$1,250 |
| Exterior Color* ¹ | Choice of Wilsonart® or Formica® non-premium laminates | Wilsonart® or Formica® premium laminates (as noted in laminate charts) Other manufacturer's laminates Stainless Steel | \$620 Call for quote \$1,250 |
| Lower Front Panel* ² | Black | Stainless Steel | \$210 |
| Upper Front Panel* ³ | Black | Silver Painted (specify color) | N/C N/C |
| Trim* ⁴ | Black | Stainless Steel | N/C |
| End Panel Style* ⁵ | Full with mirror | Case to case glass end Deduct end panel (for case to case lineups) | -\$100/end -\$240/end |
| Work Surface* ⁶ | Laminated | Solid Surface material Stainless Steel Black or White Sanalite® | Call for quote \$780 N/C |
| Base* | Levelers | Casters (not available with remote refrigeration)** | \$340 |
| Refrigeration* | Breeze™ self-contained w/ evaporator pan (rear air intake/ front air discharge at toe kick) | Remote (compressor supplied by others) Pressure release valve (required for city of Chicago) - must be ordered with case | Call for quote \$50 |
| Miscellaneous (Must be chosen when case is ordered) | | Energy efficient fans Clean Sweep® automatic condenser coil cleaner Second year parts & labor warranty (excludes compressor) | \$280 \$990 \$530 |
| Accessories (Can be purchased at any time. Refer to pages 76/77 for information) | | Price tag molding | \$130 |

*Must choose one when placing order

**May increase height of case - refer to specification sheet

| MODEL | WEIGHT | Self-Contained Refrigeration/Dry | | | Remote Refrigeration with Leads | | |
|----------|--------|----------------------------------|-------|-----------|---------------------------------|------|-------|
| | | VOLTS | AMPS | NEMA PLUG | VOLTS | AMPS | BTUH |
| FSO4837R | 950 | 120/1/60 | 15.44 | 5-20P | 120/1/60 | 1.8 | 3,359 |
| FSO7237R | 1,550 | 220/1/60* | 18.78 | 5-30P | 120/1/60 | 3.06 | 4,363 |

Freight Class: 110 NOTE: Freight rate subject to linear foot rule.

*Requires three wires plus ground.

Based on operating conditions of 75°F and 55% relative humidity. Specifications and pricing subject to change without notice.

Refrigerated Self-Service Open 60"H Case

Standard Features

- Breeze™ Refrigeration System (See page 1)
- Two full end panels with mirror interior
- Adjustable/removable, non-lighted metal shelving
- Integrated average product temperature of 41°F
- 6' power cord
- ETL sanitation conforms to NSF 7
- ETL Listed Certified to CAN/CSA 22.2
- 1 year parts and labor; 5 year compressor warranty

NOTE: Compressor air intake from rear and out front panel at toe kick. Front panel cannot be blocked.

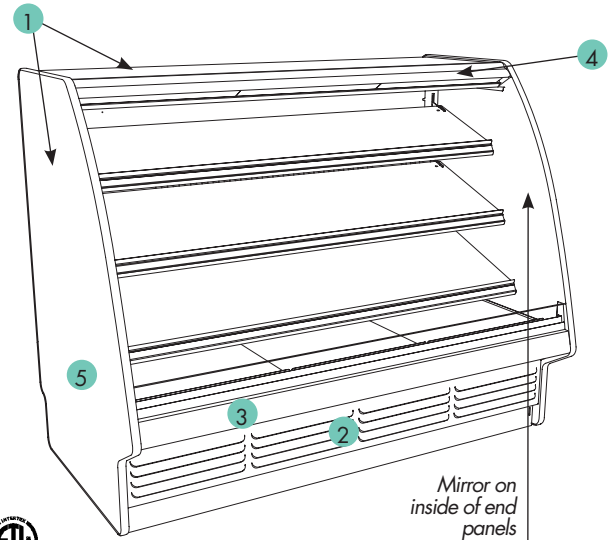

ETL
FSO7260R

| MODEL | FSO4860R | FSO7260R | FSO9660R |
|------------|--------------------|--------------------|---------------------|
| Dimensions | 51"L x 43"D x 60"H | 75"L x 43"D x 60"H | 100"L x 43"D x 60"H |
| List \$ | \$14,912 | \$16,457 | \$19,444 |

Dimensions shown are not exact. Refer to Factory Specification drawings for more detail.

| Product Specification | Standard (N/C) | Options(s) | List \$ |
|---|---|---|---|
| Interior Color* | Black | White Stainless Steel | N/C \$1,980 |
| Exterior Color* ¹ | Choice of Wilsonart® or Formica® non-premium laminates | Wilsonart® or Formica® premium laminates (as noted in laminate charts) Other manufacturer's laminates Stainless Steel | \$620 Call for quote \$1,250 |
| Lower Front Panel* ² | Black | Stainless Steel | \$210 |
| Upper Front Panel* ³ | Black | Silver Painted (specify color) | N/C N/C |
| Trim* ⁴ | Black | Silver | N/C |
| End Panel Style* ⁵ | Full with mirror | Cutaway with glass Case to case glass end Deduct end panel (for case to case lineups) | \$590/end -\$100/end -\$240/end |
| Base* | Levelers | Casters (not available with remote refrigeration)** | \$340 |
| Refrigeration* | Breeze™ self-contained w/ evaporator pan (rear air intake/ front air discharge at toe kick) | Remote (compressor supplied by others) Pressure release valve (required for city of Chicago) - must be ordered with case | Call for quote \$50 |
| Miscellaneous (Must be chosen when case is ordered) | | Lighted metal shelves (3) Rear loading doors Energy efficient fans Clean Sweep® automatic condenser coil cleaner Second year parts & labor warranty (excludes compressor) | \$660 \$1,525 \$280 \$990 \$530 |
| Accessories (Can be purchased at any time. Refer to pages 76/77 for information) | | Price tag molding | \$130 |

*Must choose one when placing order

**May increase height of case - refer to specification sheet

| MODEL | WEIGHT | Self-Contained Refrigeration/Dry | | | Remote Refrigeration with Leads | | |
|----------|--------|---|------|-----------|---------------------------------|------|------|
| | | VOLTS | AMPS | NEMA PLUG | VOLTS | AMPS | BTUH |
| FSO4860R | 850 | | | | | | |
| FSO7260R | 1,180 | Contact factory for technical electrical information | | | | | |
| FSO9660R | 1,350 | | | | | | |

Freight Class: 110 NOTE: Freight rate subject to linear foot rule.

Based on operating conditions of 75°F and 55% relative humidity. Specifications and pricing subject to change without notice.

Self-Service Refrigerated Drop-In Counter Case

Standard Features

- Breeze™ Refrigeration System (See page 1)
- Two glass end panels
- T-8 top light
- Three non-lighted metal shelves (11"D)
- 6' power cord
- Integrated average product temperature of 41°F
- ETL sanitation conforms to NSF 7
- 1 year parts and labor; 5 year compressor warranty

NOTE: Compressor air intake and discharge out rear. Counter must be configured to allow air to be drawn in and discharged out the back. Refer to specification sheet for ventilation requirements.

NOTE: Height of display case above counter is 37 1/4"

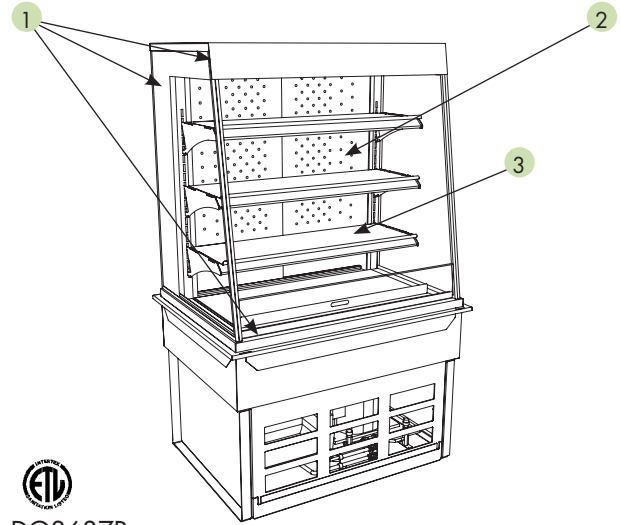

DO3637R

| MODEL | DO3637R | DO4837R |
|------------|---------------------------------|---------------------------------|
| Dimensions | 38 1/8"L x 28 5/8"D x 61 1/4" H | 50 1/8"L x 28 5/8"D x 61 1/4" H |
| List \$ | \$11,957 | \$12,850 |

Dimensions shown are not exact. Refer to Factory Specification drawings for more detail.

| Product Specification | Standard (N/C) | Option(s) | List \$ |
|---|--|--|---------------------------|
| Interior Color* | Black | Stainless Steel | \$770 |
| Exterior Color* ¹ | Black | Stainless Steel | \$350 |
| Upper Rear* ² | Solid Panel | Sliding clear glass doors with inner plexi plenum | \$1,360 |
| Shelving* ³ | Non-lighted shelves | Lighted shelves | \$850 |
| Refrigeration* | Breeze™ self-contained w/ evaporator pan (rear air intake and discharge) | Remote (compressor supplied by others) Pressure release valve (required for city of Chicago) - must be ordered with case | Call for quote \$50 |
| Miscellaneous (Must be chosen when case is ordered) | | Rear door lock Roll-down security cover, locking (increases height of case by 6") Second year parts & labor warranty (excludes compressor) | \$210 \$1,850 \$530 |
| Accessories (Can be purchased at any time. Refer to pages 76/77 for information) | | Night curtain, pull-down, non-locking Removable solid security cover, locking | \$420 \$500 |

*Must choose one when placing order

| MODEL | WEIGHT | Self-Contained Refrigeration/Dry | | | Remote Refrigeration with Leads | | |
|---------|--------|----------------------------------|-------|-----------|---------------------------------|-------|-------|
| | | VOLTS | AMPS | NEMA PLUG | VOLTS | AMPS | BTUH |
| DO3637R | 720 | 220/1/60* | 12.56 | 14-20P | 120/1/60 | 2.06 | 4,358 |
| DO4837R | 780 | 220/1/60* | 13.57 | 14-20P | 120/1/60 | 10.57 | 4,512 |

Freight Class: 110

NOTE: Freight rate subject to linear foot rule.

*Requires three wires plus ground

Based on operating conditions of 75°F and 55% relative humidity. Specifications and pricing subject to change without notice.

Self-Service Refrigerated Drop-In Counter Case

Standard Features

- Breeze™ Refrigeration System (See page 1)
- Two glass end panels
- T-8 top light
- One non-lighted shelf (11"D)
- 6' power cord
- Integrated average product temperature of 41°F
- ETL sanitation conforms to NSF 7
- 1 year parts and labor; 5 year compressor warranty

NOTE: Compressor air intake and discharge out rear. Counter must be configured to allow air to be drawn in and discharged out the back. Refer to specification sheet for ventilation requirements.

NOTE: Height of display case above counter is 23 1/4"

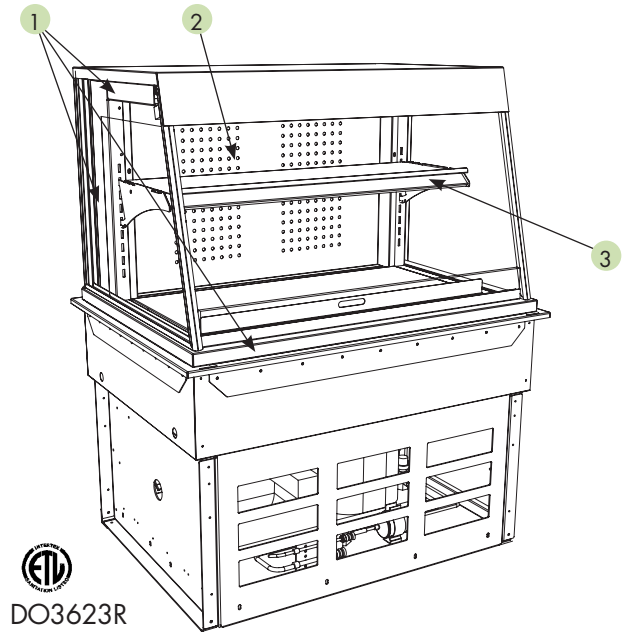

| MODEL | DO3623R | DO4823R |
|------------|-----------------------------|-----------------------------|
| Dimensions | 38 1/8"L x 28 5/8"D x 47" H | 50 1/8"L x 28 5/8"D x 47" H |
| List \$ | \$10,861 | \$11,757 |

Dimensions shown are not exact. Refer to Factory Specification drawings for more detail.

| Product Specification | Standard (N/C) | Option(s) | List \$ |
|---|--|--|---------------------------|
| Interior Color* | Black | Stainless Steel | \$770 |
| Exterior Color* 1 | Black | Stainless Steel | \$350 |
| Upper Rear* 2 | Solid Panel | Sliding clear glass doors with inner plexi plenum | \$1,360 |
| Shelving* 3 | Non-lighted shelf | Lighted shelf 3"H Display step (in lieu of shelf) | \$330 N/C |
| Refrigeration* | Breeze™ self-contained w/ evaporator pan (rear air intake and discharge) | Remote (compressor supplied by others) Pressure release valve (required for city of Chicago) - must be ordered with case | Call for quote \$50 |
| Miscellaneous (Must be chosen when case is ordered) | | Rear door lock Roll-down security cover, locking (increases height of case by 6") Second year parts & labor warranty (excludes compressor) | \$210 \$1,850 \$530 |
| Accessories (Can be purchased at any time. Refer to pages 76/77 for information) | | Night curtain, pull-down, non-locking Removable solid security cover, locking | \$420 \$500 |

*Must choose one when placing order

| MODEL | WEIGHT | Self-Contained Refrigeration/Dry | | | Remote Refrigeration with Leads | | |
|---------|--------|----------------------------------|-------|-----------|---------------------------------|-------|-------|
| | | VOLTS | AMPS | NEMA PLUG | VOLTS | AMPS | BTUH |
| DO3623R | 600 | 120/1/60 | 15.56 | 5-20P | 120/1/60 | 9.56 | 2,200 |
| DO4823R | 700 | 220/1/60* | 13.17 | 14-20P | 120/1/60 | 10.25 | 2,817 |

Freight Class: 110

NOTE: Freight rate subject to linear foot rule.

*Requires three wires plus ground.

Based on operating conditions of 75°F and 55% relative humidity. Specifications and pricing subject to change without notice.

Self-Service Refrigerated Drop-In Counter Case

Standard Features

- Breeze™ Refrigeration System (See page 1)
- Two glass end panels
- T-8 top light
- 6' power cord
- Integrated average product temperature of 41°F
- ETL sanitation conforms to NSF 7
- ETL Listed Certified to CAN/CSA 22.2
- 1 year parts and labor; 5 year compressor warranty

NOTE: Compressor air intake and discharge out rear of case. Counter must be configured to allow proper ventilation around refrigeration package.

NOTE: Height of display case above counter is 15 1/2"

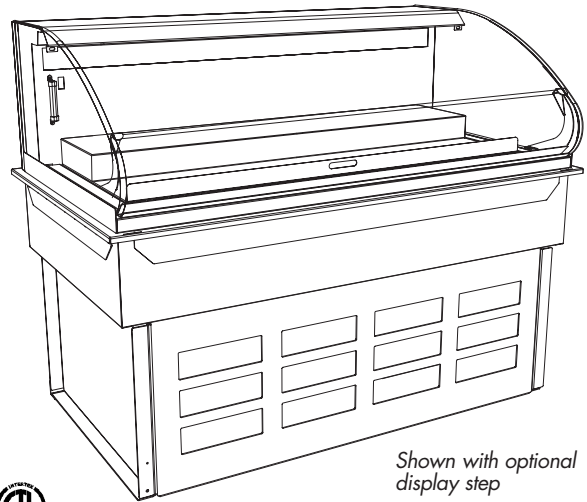

Shown with optional display step



DO4816R

This model may require additional lead time

| MODEL | DO3616R | DO4816R |
|------------|---------------------------------|---------------------------------|
| Dimensions | 38 1/8"L x 28 3/4"D x 39 1/2" H | 50 1/8"L x 28 3/4"D x 39 1/2" H |
| List \$ | \$8,717 | \$9,177 |

Dimensions shown are not exact. Refer to Factory Specification drawings for more detail.

| Product Specification | Standard (N/C) | Option(s) | List \$ |
|---|--|---|-------------------------|
| Interior/Exterior Color* | Black | Stainless Steel | \$640 |
| Refrigeration* | Breeze™ self-contained w/ evaporator pan (rear air intake and discharge) | Remote (compressor supplied by others) Pressure release valve (required for city of Chicago) - must be ordered with case | Call for quote \$50 |
| Miscellaneous (Must be chosen when case is ordered) | | Second year parts & labor warranty (excludes compressor) | \$530 |
| Accessories (Can be purchased at any time. Refer to pages 76/77 for information) | | Night curtain, pull-down, non-locking Removable solid security cover, locking Display step | \$420 \$500 \$530 |

*Must choose one when placing order

| MODEL | WEIGHT | Self-Contained Refrigeration/Dry | | | Remote Refrigeration with Leads | | |
|---------|--------|----------------------------------|------|-----------|---------------------------------|------|-------|
| | | VOLTS | AMPS | NEMA PLUG | VOLTS | AMPS | BTUH |
| DO3616R | 600 | 120/1/60 | 6.13 | 5-15P | 120/1/60 | .85 | 1,330 |
| DO4816R | 700 | 120/1/60 | 9.06 | 5-15P | 120/1/60 | 1.06 | 1,805 |

Freight Class: 110 NOTE: Freight rate subject to linear foot rule.

Based on operating conditions of 75°F and 55% relative humidity. Specifications and pricing subject to change without notice.

Service/Self-Service Non-Refrigerated Countertop Case - Straight Front

Standard Features

- Clear glass swinging doors
- Straight front glass and ends
- T-8 top light
- Three lighted shelves
- Shelves adjustable/removable for service & self-service application
- 6' power cord
- ETL sanitation conforms to NSF 2
- ETL Listed Certified to CAN/CSA 22.2
- One year parts and labor warranty

NOTE: Case can be reversed to provide rear door access for customer self-service. Shelf brackets are adjustable to accommodate new position.

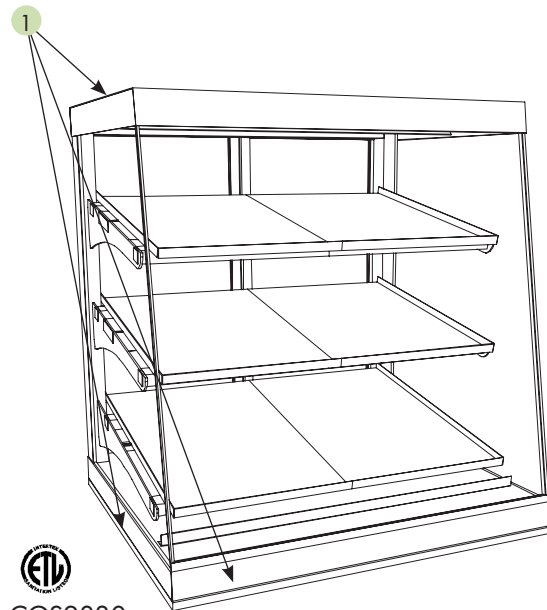

| MODEL | CGS2830 | CGS3830 |
|------------|-------------------------|-------------------------|
| Dimensions | 28"L x 25"D x 30 1/2" H | 38"L x 25"D x 30 1/2" H |
| List \$ | \$4,436 | \$4,682 |

Dimensions shown are not exact. Refer to Factory Specification drawings for more detail.

| Product Specification | Standard (N/C) | Option(s) | List \$ |
|--|----------------|------------------------------------|---------|
| Interior/Exterior Color* ¹ | Black | Stainless Steel | \$640 |
| Miscellaneous (Must be chosen when case is ordered) | | Second year parts & labor warranty | \$530 |

*Must choose one when placing order

| MODEL | WEIGHT | Self-Contained Refrigeration/Dry | | |
|---------|--------|----------------------------------|------|-----------|
| | | VOLTS | AMPS | NEMA PLUG |
| CGS2830 | 270 | 120/1/60 | .60 | 5-15P |
| CGS3830 | 350 | 120/1/60 | .60 | 5-15P |

Freight Class: 125 NOTE: Freight rate subject to linear foot rule.

Based on operating conditions of 75°F and 55% relative humidity. Specifications and pricing subject to change without notice.

Service/Self-Service Non-Refrigerated Countertop Case - Curved Front

Standard Features

- Clear glass swinging doors
- Curved front glass and ends
- T-8 top light
- Three lighted shelves
- Shelves adjustable/removable for service & self-service applications
- 6' power cord
- ETL sanitation conforms to NSF 2
- ETL Listed Certified to CAN/CSA 22.2
- One year parts and labor warranty

NOTE: Case can be reversed to provide rear door access for customer self-service. Shelf brackets are adjustable to accommodate new position.

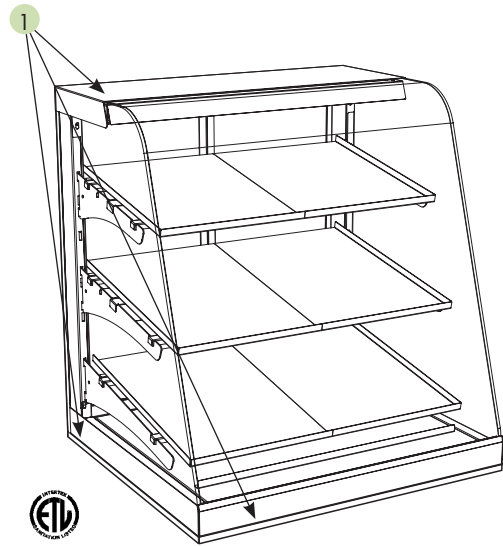

ETL
CGC2830

| MODEL | CGC2830 | CGC3830 |
|------------|-------------------------|-------------------------|
| Dimensions | 28"L x 25"D x 30 1/2" H | 38"L x 25"D x 30 1/2" H |
| List \$ | \$4,831 | \$5,209 |

Dimensions shown are not exact. Refer to Factory Specification drawings for more detail.

| Product Specification | Standard (N/C) | Option(s) | List \$ |
|--|----------------|------------------------------------|---------|
| Interior/Exterior Color* ¹ | Black | Stainless Steel | \$640 |
| Miscellaneous (Must be chosen when case is ordered) | | Second year parts & labor warranty | \$530 |

*Must choose one when placing order

| MODEL | WEIGHT | Self-Contained Refrigeration/Dry | | |
|---------|--------|----------------------------------|------|-----------|
| | | VOLTS | AMPS | NEMA PLUG |
| CGC2830 | 400 | 120/1/60 | .6 | 5-15P |
| CGC3830 | 450 | 120/1/60 | .6 | 5-15P |

Freight Class: 125 NOTE: Freight rate subject to linear foot rule.

Based on operating conditions of 75°F and 55% relative humidity. Specifications and pricing subject to change without notice.

Self-Service Non-Refrigerated Countertop Case

Standard Features

- Four tray support shelves (18"D)
- Black interior color and frame
- Self-closing swinging front doors
- T-5 side lights with protective shields
- 12" power cord
- ETL Listed Certified to CAN/CSA 22.2
- 1 year parts and labor warranty

Quick-Ship
See page 10

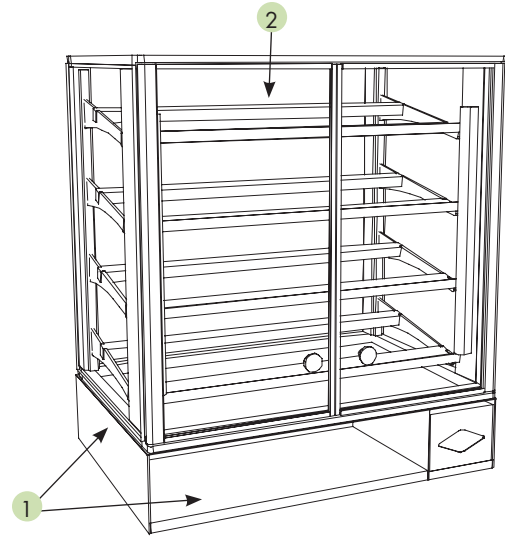

CSC3223

NOTE: Holds (4) 18"x26" trays. Trays not supplied with unit.

| MODEL | CSC3223 |
|------------|---------------------------------|
| Dimensions | 31 1/2"L x 23 1/8"D x 36 3/8" H |
| List \$ | \$3,515 |

Dimensions shown are not exact. Refer to Factory Specification drawings for more detail.

| Product Specification | Standard (N/C) | Option(s) | List \$ |
|--|--------------------------|--|-------------------------|
| Base* ¹ | 6"H with bag area (Gray) | 2"H without bag area (Black) 6"H with bag area (Black) | \$180 \$250 |
| Graphics | None | 10" header sign, plain, clear acrylic 10" header sign, with graphics (customer supplied artwork) Front door graphics (customer supplied artwork) | \$160 \$450 \$185 |
| Rear* ² | Solid Panel | Mirrored panel Clear glass swinging doors | \$160 \$500 |
| Miscellaneous (Must be chosen when case is ordered) | | Second year parts & labor warranty | \$530 |

*Must choose one when placing order

| MODEL | WEIGHT | Self-Contained Refrigeration/Dry | | |
|---------|--------|----------------------------------|------|-----------|
| | | VOLTS | AMPS | NEMA PLUG |
| CSC3223 | 300 | 120/1/60 | .28 | 5-15P |

Freight Class: 125 NOTE: Freight rate subject to linear foot rule.

Based on operating conditions of 75°F and 55% relative humidity.
Specifications and pricing subject to change without notice.

Upright Self-Service Pastry Case - 65 1/4"H

Standard Features

- Two glass end panels
- Four tray support shelves (26"D)
- Black interior color and frame
- Self-closing swinging front doors
- T-5 side lights
- 12" power cord
- ETL Listed Certified to CAN/CSA 22.2
- 1 year parts and labor warranty

Quick-Ship
See page 10

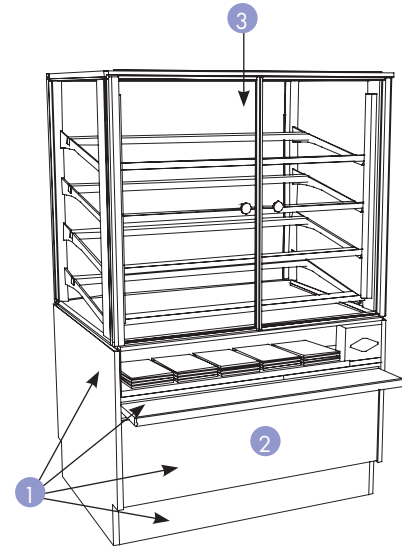

CSF4231

NOTE: Holds (8) 18"x26" trays. Trays not supplied with unit.

| MODEL | CSF4231 |
|------------|----------------------------|
| Dimensions | 42"L x 36 1/2"D x 65 1/4"H |
| List \$ | \$4,982 |

Dimensions shown are not exact. Refer to Factory Specification drawings for more detail.

| Product Specification | Standard (N/C) | Option(s) | List \$ |
|--|--------------------------------------|--|---------------------------------------|
| Exterior* ¹ | Gray | Black Wilsonart® or Formica® non-preium laminate (as noted in laminate charts) Wilsonart® or Formica® preium laminate (as noted in laminate charts) Other manufacturer's laminate | N/C N/C \$620 Call for quote |
| Base* ² | Straight base with 6"D package ledge | Base with storage door and ledge Base with storage door and without ledge | \$190 N/C |
| Graphics* | None | Front door graphics (customer supplied artwork) Header sign, plain Header sign, with graphics (customer supplied artwork) | \$190 \$220 \$520 |
| Upper Rear* ³ | Solid back panel | Clear glass swinging doors without lock Reflective glass swinging doors without lock | \$660 \$800 |
| Miscellaneous (Must be chosen when case is ordered) | | Second year parts & labor warranty | \$530 |

*Must choose one when placing order

| MODEL | WEIGHT | Self-Contained Refrigeration/Dry | | |
|---------|--------|----------------------------------|------|-----------|
| | | VOLTS | AMPS | NEMA PLUG |
| CSF4231 | 650 | 120/1/60 | .61 | 5-15P |

Freight Class: 125 NOTE: Freight rate subject to linear foot rule.

Based on operating conditions of 75°F and 55% relative humidity.
Specifications and pricing subject to change without notice.

Upright Self-Service Pastry Case - 83 1/4"H

Standard Features

- Four adjustable/removable tray support shelves
- Two full end panels with mirror interior
- Solid upper back panel
- Open lower rear storage
- Single pane glass front swinging doors with stay open feature
- Straight laminated front panel
- T-8 top and shelf lights
- 12" power cord
- ETL Listed Certified to CAN/CSA 22.2
- 1 year parts and labor warranty

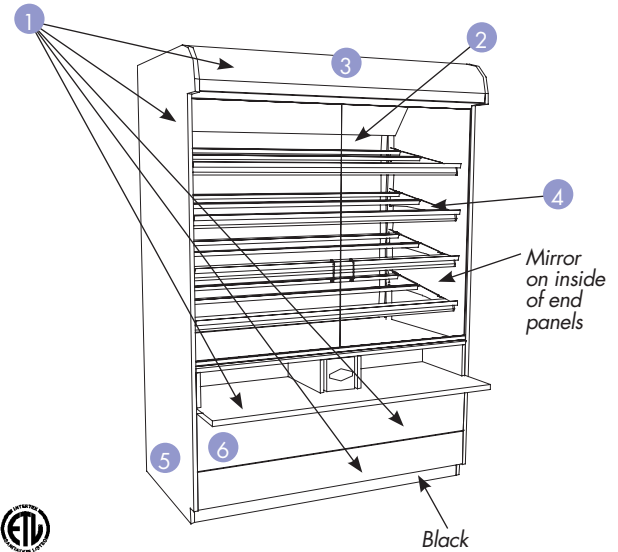

PC5682

| MODEL | PC3982 | PC5682 | PC7482 |
|------------|------------------------|------------------------|------------------------|
| Dimensions | 41"L x 39"D x 83 1/4"H | 58"L x 39"D x 83 1/4"H | 76"L x 39"D x 83 1/4"H |
| List \$ | \$7,315 | \$8,370 | \$9,791 |

Dimensions shown are not exact. Refer to Factory Specification drawings for more detail.

| Product Specification | Standard (N/C) | Option(s) | List \$ |
|---|--------------------------------|--|--------------------------------------|
| Interior Color* | White | Black | \$420 |
| Exterior Color* ¹ | Painted (specify color) | Wilsonart® or Formica® non-premium laminates (as noted in laminate charts) Wilsonart® or Formica® premium laminates (as noted in laminate charts) Other manufacturer's laminates | N/C \$620 Call for quote |
| Upper Rear* ² | Solid back panel - white | Mirror back panel Mirror sliding doors Reflective glass sliding doors | \$290 \$670 \$540 |
| Header Style* ³ | Curved | Square | \$400 |
| Shelving* ⁴ | Tray support shelves, 26"D | Chrome wire racks, 26"D Black wire racks, 26"D | \$300 \$300 |
| End Panel Style* ⁵ | Full with mirror | Cutaway with glass Case to case end glass Deduct end panel (for case to case lineups) | \$490/end \$140/end -\$240/end |
| Base Style* ⁶ | Straight without front storage | Straight with front storage and waste bin Angled with front storage and waste bin | \$350 \$490 |
| Miscellaneous (Must be chosen when case is ordered) | | Rear sliding storage doors Second year parts & labor warranty | \$140 \$530 |
| Accessories (Can be purchased at any time. Refer to pages 76/77 for information) | | Price tag moulding | \$210 |

*Must choose one when placing order

| MODEL | WEIGHT | Self-Contained Refrigeration/Dry | | |
|--------|--------|----------------------------------|------|-----------|
| | | VOLTS | AMPS | NEMA PLUG |
| PC3982 | 900 | 120/1/60 | 1.43 | 5-15P |
| PC5682 | 920 | 120/1/60 | 1.84 | 5-15P |
| PC7482 | 1,150 | 120/1/60 | 2.12 | 5-15P |

Freight Class: 125 NOTE: Freight rate subject to linear foot rule.

Based on operating conditions of 75°F and 55% relative humidity. Specifications and pricing subject to change without notice.

Upright Self-Service Pastry/Hard Roll Case 83 1/4"H

Standard Features

- Two adjustable/removable tray support shelves
 - PHRM5682 Capacity: (18) 9"x26" trays (not supplied)
 - PHRM7482 Capacity: (24) 9"x26" trays (not supplied)
- One row of acrylic bins below doors
 - (4) in model PHRM5682
 - (6) in model PHRM7482
- Two full end panels with mirror interior
- Solid upper back panel
- Open lower rear storage
- Single pane glass front swinging doors with stay open feature
- Straight laminated front panel
- T-8 top and shelf lights
- 12" power cord
- ETL Listed Certified to CAN/CSA 22.2
- 1 year parts and labor warranty

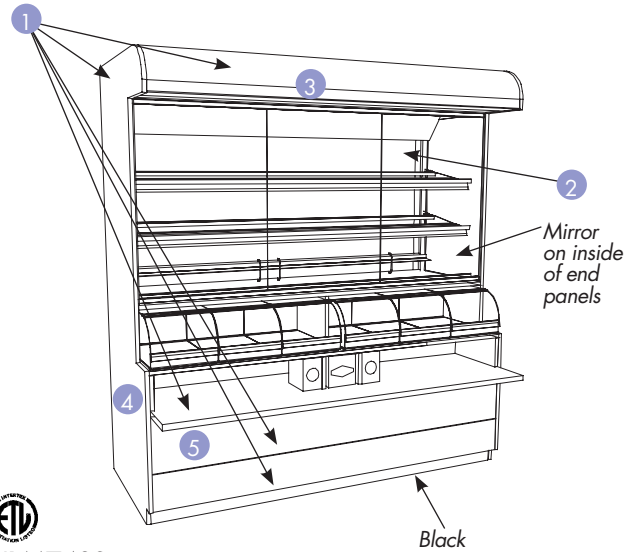

PHRM7482

Note: Trays not supplied with case.

| MODEL | PHRM5682 | PHRM7482 |
|------------|------------------------|------------------------|
| Dimensions | 58"L x 39"D x 83 1/4"H | 76"L x 39"D x 83 1/4"H |
| List \$ | \$9,791 | \$11,495 |

Dimensions shown are not exact. Refer to Factory Specification drawings for more detail.

| Product Specification | Standard (N/C) | Option(s) | List \$ |
|---|--------------------------------|--|--------------------------------------|
| Interior Color* ¹ | White | Black | \$420 |
| Exterior Color* ¹ | Painted (specify color) | Wilsonart® or Formica® non-premium laminates (as noted in laminate charts) Wilsonart® or Formica® premium laminates (as noted in laminate charts) Other manufacturer's laminates | N/C \$620 Call for quote |
| Upper Rear* ² | Solid back panel - white | Mirror back panel Reflective sliding doors | \$290 \$550 |
| Header Style* ³ | Curved | Square | \$420 |
| End Panel Style* ⁴ | Full with mirror | Cutaway with glass Case to case end glass Deduct end panel (for case to case lineups) | \$490/end \$140/end -\$240/end |
| Base Style* ⁵ | Straight without front storage | Straight with front storage and waste bin Angled with front storage and waste bin | \$350 \$490 |
| Miscellaneous (Must be chosen when case is ordered) | | Rear sliding storage doors Second year parts & labor warranty | \$140 \$530 |
| Accessories (Can be purchased at any time. Refer to pages 76/77 for information) | | Price tag molding | \$210 |

*Must choose one when placing order

| MODEL | WEIGHT | Self-Contained Refrigeration/Dry | | |
|----------|--------|----------------------------------|------|-----------|
| | | VOLTS | AMPS | NEMA PLUG |
| PHRM5682 | 1,050 | 120/1/60 | 1.06 | 5-15P |
| PHRM7482 | 1,100 | 120/1/60 | 1.37 | 5-15P |

Freight Class: 125 NOTE: Freight rate subject to linear foot rule.

Based on operating conditions of 75°F and 55% relative humidity.
Specifications and pricing subject to change without notice.

Upright Self-Service Shelving/Hard Roll Case 83 1/4"H

Standard Features

- Two adjustable/removable hard roll shelves (18"D)
- Two rows of acrylic bins
 - (8) in model SHRM5682
 - (12) in model SHRM7482
- Two full end panels with mirror interior
- Solid upper back panel
- Open lower storage
- T-8 top and shelf lights
- 12" power cord
- ETL Listed Certified to CAN/CSA 22.2
- 1 year parts and labor warranty

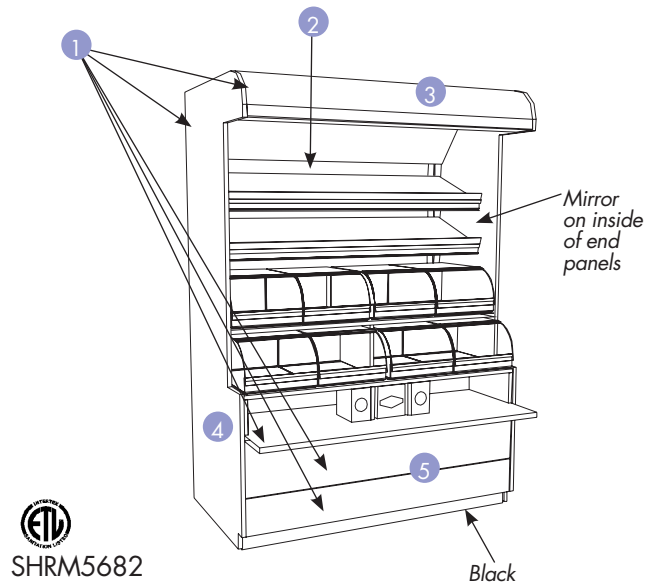

ETL
SHRM5682

| MODEL | SHRM5682 | SHRM7482 |
|------------|------------------------|------------------------|
| Dimensions | 58"L x 39"D x 83 1/4"H | 76"L x 39"D x 83 1/4"H |
| List \$ | \$9,791 | \$11,495 |

Dimensions shown are not exact. Refer to Factory Specification drawings for more detail.

| Product Specification | Standard (N/C) | Option(s) | List \$ |
|---|--------------------------------|--|--------------------------------|
| Interior Color* ¹ | White | Black | \$420 |
| Exterior Color* ¹ | Painted (specify color) | Wilsonart® or Formica® non-premium laminates (as noted in laminate charts) Wilsonart® or Formica® premium laminates (as noted in laminate charts) Other manufacturer's laminates | N/C \$620 Call for quote |
| Upper Rear* ² | Solid back panel - white | Mirror back panel | \$290 |
| Header Style* ³ | Curved | Square | \$420 |
| End Panel Style* ⁴ | Full with mirror | Cutaway without glass Deduct end panel for case to case lineups | \$410/end -\$240/end |
| Base Style* ⁵ | Straight without front storage | Straight with front storage and waste bin Angled with front storage and waste bin | \$350 \$490 |
| Miscellaneous (Must be chosen when case is ordered) | | Rear sliding storage doors Second year parts & labor warranty | \$140 \$530 |
| Accessories (Can be purchased at any time. Refer to pages 76/77 for information) | | Price tag molding | \$210 |

*Must choose one when placing order

| MODEL | WEIGHT | Self-Contained Refrigeration/Dry | | |
|----------|--------|----------------------------------|------|-----------|
| | | VOLTS | AMPS | NEMA PLUG |
| SHRM5682 | 900 | 120/1/60 | 1.06 | 5-15P |
| SHRM7482 | 1,100 | 120/1/60 | 1.37 | 5-15P |

Freight Class: 125 NOTE: Freight rate subject to linear foot rule.

Based on operating conditions of 75°F and 55% relative humidity.
Specifications and pricing subject to change without notice.

ACCESSORIES & MISCELLANEOUS OPTIONS

Display Steps



2" H Display Steps (for lower area). **E**

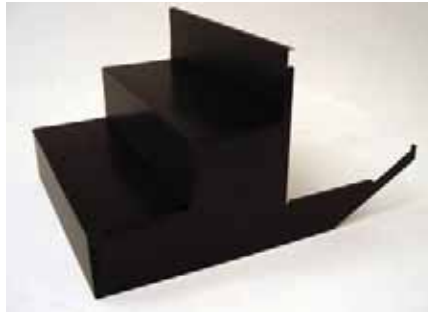

4" H Display Steps (for lower area). **E**



Display Steps For model C3Z(L)67 (for lower area). **O**



Display Steps For models CO2739R and COU2757R (for lower area). **O**



3" H Display Steps For model FSDG(L)R.T1 (N/A with shelf). **F**



Display Steps For model DO(L)16R. **I**

Security Covers, Night Curtain & Package Ledge



Wire Security Cover
Removable, locking wire security cover includes two padlocks keyed alike.

E H O F I



Solid Security Cover
Removable, locking solid aluminum security cover with Stardust Silver powder-coated finish.

O I



Roll-Down Locking Security Covers

Cover rolls up into the header when not in use. This feature must be specified when ordering case. Roll-down covers increase the height of the case as noted on specific models. **O I**



Night Curtain

Pull-down non-locking energy efficient curtain. **E H O F I**



6 3/4" D Front Package Ledge

This feature must be specified when ordering case. **R**

NOTE: See model pages for case specific compatibility

E = Encore, **H** = Harmony, **R** = Renaissance, **O** = Oasis, **F** = Fusion, **I** = Impulse, **A** = Addenda

ACCESSORIES & MISCELLANEOUS OPTIONS



Scale Stand
Stainless steel scale stand with appliance receptacle requires separate electrical circuit. This feature must be specified when ordering case. **R F**



Rear Wrapping Board
Wrapping board is constructed of white Sanalite®. Removable without tools for cleaning. **E H R F**



Price Tag Molding **E H R O F**
I A



1 1/2" H Wire Baskets
for HVB(L)SS cases. Available in black or chrome. **E**



4" H Wire Baskets
For HVB(L)SS cases. Black only. **E**

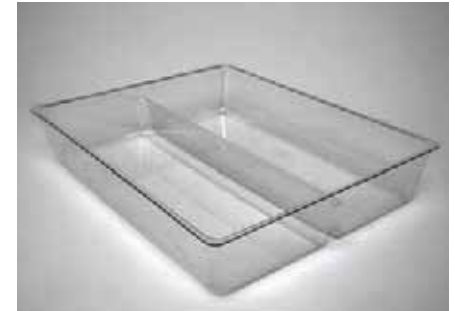

Clear Liner / Divider
For Wire baskets in HVB(L)SS cases. Available in 1 1/2" H & 4" H. **E**



Bottle Slide
Gravity fed bottle slide for lower area of HMBC(L) cases. **H**



Control Knob Guards
For hot cases. **R F**



Acrylic Candy Trays
For Model RCG(L)48R. See page 43 for size dimensions and quantities per case. **R**

Laminates

Structural Concepts has partnered with both Wilsonart® and Formica® to offer all of their "non-premium" laminate collections at no additional cost to our customers. An upcharge will apply to laminates noted as "premium" from these collections. Case lead time may be affected with the use of "premium" laminates. Full color Wilsonart® or Formica® charts are available from our company representatives or can be viewed online via the manufacturer's website at: www.wilsonart.com and www.formica.com

Other manufacturer's (ie: Pionite®, Nevamar® etc.) laminates are available. Contact us for details or quote.

NOTE: See model pages for case specific compatibility
E = Encore, **H** = Harmony, **R** = Renaissance, **O** = Oasis, **F** = Fusion, **I** = Impulse, **A** = Addenda



ACCESSORIES AND OPTIONS

FOODSERVICE REPRESENTATIVE LIST

ALABAMA

The Hansen Group
Phone 770-667-1544
Fax 770-667-1491
sales@thehansengroup.net

ALASKA

Roller & Associates
Phone 509-990-5520
Fax 509-272-1770
steve@rollerassoc.com

ARIZONA

Johnson Pike & Associates Inc.
Phone 303-572-0084
Fax 303-572-8152
jpa@johnsonpike.com

ARKANSAS

The Wallin Group
Phone 501-663-2438
Fax 501-663-2439
jheimbach@wallingroup.com

CALIFORNIA

Southern CA
Hodak Kolstad Marketing
Zip Codes: 90000-93499
Phone 714-898-1003
Fax 714-898-5438
info@hodakkolstad.com

Northern CA
Premier Marketing Group
Zip Codes: 93500-96699
Phone 916-361-9500
Fax 916-361-4500
premiermktg@kitchenreps.com

COLORADO

Johnson Pike & Associates Inc.
Phone 303-572-0084
Fax 303-572-8152
jpa@johnsonpike.com

CONNECTICUT

Hatch-Jennings
Zip Codes: 06000-06700
Phone 978-456-8702
Fax 978-456-8067
kristenp@hatch-jennings.com

Posternak-Bauer Associates
Zip Codes: 06800-06999
Phone 914-793-9000
Fax 914-793-9209
info@pbarep.com

DELAWARE

BHG/Nordon
Phone 856-910-8070
Fax 856-910-8072
info@bachovinhealygroup.com

FLORIDA

Preferred Marketing Agents
Zip Codes: 32000-32399 &
32600-34999
Phone 954-943-1661
Fax 954-943-9209
jkinni@pmafla.com

The Hansen Group
Zip Codes: 32400-32599
Phone 770-667-1544
Fax 770-667-1491
sales@thehansengroup.net

GEORGIA

The Hansen Group
Phone 770-667-1544
Fax 770-667-1491
sales@thehansengroup.net

HAWAII

Pacific Rim Rep Group
Phone 808-524-8884
Fax 808-524-8817
ms-prreps@hawaii.rr.com

IDAHO

Roller & Associates
Phone: 509-990-5520
Fax 509-272-1770
steve@rollerassoc.com

ILLINOIS

Elite Marketing
Zip Codes: 60000-61899 &
60601-60701
Phone 630-516-9260
Fax 630-516-9261
jdziuban@elitemarketinginc.net

Burlis-Lawson Group, Inc.
Zip Codes: 61900-62999
Phone 636-391-0086
Fax 636-391-9391
sharon@burlislawson.com

INDIANA

HRI, Inc.
Zip Codes: 46000-46302 &
46412-47999
Phone 586-771-0335
Fax 586-771-3083
info@hri-inc.com

Elite Marketing
Zip Codes: 46303-46411
Phone 630-516-9260
Fax 630-516-9261
jdziuban@elitemarketinginc.net

IOWA

Burlis-Lawson Group, Inc.
Phone 515-277-5876
Fax 515-277-5896
todd@burlislawson.com

KANSAS

Burlis-Lawson Group, Inc.
Phone 913-599-2210
Fax 913-599-2517
debbie@burlislawson.com

KENTUCKY

WB Marketing
Phone 440-842-2800
Fax 440-842-2833
rose@wbmarket.net

LOUISIANA

The Wallin Group
Phone 504-733-3344
Fax 504-733-0854
swray@wallingroup.com

MAINE

Hatch-Jennings
Phone 978-456-8702
Fax 978-456-8067
kristenp@hatch-jennings.com

MARYLAND

Lane Marketing Group
Phone 410-974-1108
Fax 410-757-0293
hdq@lanegroup.com

MASSACHUSETTS

Hatch-Jennings
Phone 978-456-8702
Fax 978-456-8067
kristenp@hatch-jennings.com

MICHIGAN

HRI, Inc.
Zip Codes: 48000-49799 &
49901-49999
Phone 586-771-0335
Fax 586-771-3083
info@hri-inc.com

Clark, Malone & Associates
Northern MI (UP)
Zip Codes: 49800-49900
Phone 414-326-3600
Fax 414-326-3601
bob@clarkmalone.com

MINNESOTA

Hollander Company
Phone 952-829-5500
Fax 952-829-9664
admin@hollandercompany.com

MISSISSIPPI

The Wallin Group
Phone 601-992-7260
Fax 601-992-7350
tsimmons@wallingroup.com

MISSOURI

Burlis-Lawson Group, Inc.
Phone 636-391-0086
Fax 636-391-9391
sharon@burlislawson.com

MONTANA

Johnson Pike & Associates Inc.
Phone 303-572-0084
Fax 303-572-8152
jpa@johnsonpike.com

NEBRASKA

Burlis-Lawson Group, Inc.
Phone 913-599-2210
Fax 913-599-2517
debbie@burlislawson.com

NEVADA

Hodak Kolstad Marketing
Zip Codes: 89000-89199
Phone 714-898-1003
Fax 714-898-5438
info@hodakkolstad.com

Premier Marketing Group
(Northern)
Zip Codes: 89300-89899
Phone 916-361-9500
Fax 916-361-4500
premiermktg@kitchenreps.com

FOODSERVICE REPRESENTATIVE LIST

NEW HAMPSHIRE

Hatch-Jennings
Phone 978-456-8702
Fax 978-456-8067
kristenp@hatch-jennings.com

NEW JERSEY

Posternak-Bauer Associates
Zip Codes: 07000-07999 &
08800-08999
Phone 914-793-9000
Fax 914-793-9209
info@pbarep.com

BHG/Nordon
Zip Codes: 08000-08799
Phone 856-910-8070
Fax 856-910-8072
info@bachovinhealygroup.com

NEW MEXICO

Johnson Pike & Associates Inc.
Phone 303-572-0084
Fax 303-572-8152
jpa@johnsonpike.com

NEW YORK

Link2 Hospitality Solutions
Zip Codes: 12000-14999
Phone 585-254-1780
Fax 585-254-2154
rward@qualityrepsource.com

Posternak-Bauer Associates
Zip Codes: 10000-11999
Phone 914-793-9000
Fax 914-793-9209
info@pbarep.com

NORTH CAROLINA

Swanson-Girard & Associates
Phone 704-521-8811
Fax 704-521-8801
bschaab@swanson-girard.com

NORTH DAKOTA

Hollander Company
Phone 952-829-5500
Fax 952-829-9664
admin@hollandercompany.com

OHIO

WB Marketing
Phone 440-842-2800
Fax 440-842-2833
rose@wbmarket.net

OKLAHOMA

Ettinger-Rosini & Assoc.
Phone 214-343-2548
Fax 214-343-2727
toni@ettros.com

OREGON

Roller & Associates
Phone 503-890-6477
Fax 360-882-0637
lenny@rollerassoc.com

PENNSYLVANIA

BHG/Nordon
Zip Codes: 16900-19669
Phone 856-910-8070
Fax 856-910-8072
info@bachovinhealygroup.com

WB Marketing
Zip Codes: 15000-16899
Phone 440-842-2800
Fax 440-842-2833
rose@wbmarket.net

RHODE ISLAND

Hatch-Jennings
Phone 978-456-8702
Fax 978-456-8067
kristenp@hatch-jennings.com

SOUTH CAROLINA

Swanson-Girard & Associates
Phone 704-521-8811
Fax 704-521-8801
bschaab@swanson-girard.com

SOUTH DAKOTA

Hollander Company
Phone 952-829-5500
Fax 952-829-9664
admin@hollandercompany.com

TENNESSEE

The Hansen Group
Zip Codes: 37000-37999 &
38400-38900
Phone 770-667-1544
Fax 770-667-1491
sales@thehansengroup.net

The Wallin Group
Zip Codes: 38000-38399
Phone 901-370-4724
Fax 901-370-4734
dlaagraize@wallingroup.com

TEXAS

Ettinger-Rosini & Assoc.
Zip Codes: 75000-79799
Phone 214-343-2548
Fax 214-343-2727
toni@ettros.com

Johnson Pike & Associates Inc.
Zip Codes: 79800-79999
Phone 303-572-0084
Fax 303-572-8152
jpa@johnsonpike.com

UTAH

Johnson Pike & Associates Inc.
Phone 303-572-0084
Fax 303-572-8152
jpa@johnsonpike.com

VERMONT

Hatch-Jennings
Phone 978-456-8702
Fax 978-456-8067
kristenp@hatch-jennings.com

VIRGINIA

Lane Marketing Group
Phone 410-974-1108
Fax 410-757-0293
hdq@lanegroup.com

WASHINGTON D.C.

Lane Marketing Group
Phone 410-974-1108
Fax 410-757-0293
hdq@lanegroup.com

WASHINGTON

Roller & Associates
Phone 206-547-3555
Fax 206-547-8630
customerservice@rollerassoc.com

WEST VIRGINIA

Lane Marketing Group (Charleston)
Zip Codes: 25000-25399
Phone 410-974-1108
Fax 410-757-0293
hdq@lanegroup.com

WB Marketing (except Charleston)
Zip Codes: 24700-24999 &
25400-26884
Phone 440-842-2800
Fax 440-842-2833
rose@wbmarket.net

WISCONSIN

Hollander Company (LaCrosse)
Zip Codes: 54601-54603
Phone 952-829-5500
Fax 952-829-9664
admin@hollandercompany.com

Clark, Malone & Associates (except LaCrosse)
Zip Codes: 53000-54600 &
54604-54999
Phone 414-326-3600
Fax 414-326-3601
bob@clarkmalone.com

WYOMING

Johnson Pike & Associates Inc.
Phone 303-572-0084
Fax 303-572-8152
jpa@johnsonpike.com

CANADA

Consult Factory
Christine Clark (Customer Service)
Phone 800-433-0142

MEXICO, SOUTH AMERICA, CARIBBEAN, CENTRAL AMERICA, COSTA RICA, VENEZUELA, PUERTO RICO

MerkolAT
Phone 561-961-1389
Fax 561-792-6351
info@merkolat.com

MASTER SERVICE AGENT LISTING

To process a request for **WARRANTY RELATED SERVICE**, please follow the steps below:

1. Identify the unit's model and serial numbers. This information can be found on the silver serial label attached to the unit. The serial label is typically on the rear of the merchandiser near your electrical access.
2. Contact the Master Service Agent for your area.
3. Master Service Agent will invoice Structural Concepts if the issue is covered under warranty. The customer will be responsible for non-warranty claims (e.g. routine maintenance, operator inflicted damage, tampering with settings by non-authorized service contractor, etc.)

*If you do not see your state listed, or for additional updates, please visit our website at www.structuralconcepts.com or call your Technical Service Rep.

*If you have a service contractor that you work with on a regular basis, please share this information with our Technical Service Representative. In most cases, we will honor your request to have a specific contractor do the service work, but will need to contact them first to authorize repair and invoicing.

| STATE | COMPANY NAME | PHONE | FAX |
|-------------------------------|-------------------------------|--------------|--------------|
| ALABAMA | | | |
| Birmingham | Heritage Service Group | 205-833-1216 | 205-833-1690 |
| Leeds | Southeast Company | 205-699-5777 | 205-699-5019 |
| Mobile | Air Tec Refrigeration | 251-639-1137 | 251-639-1138 |
| Montgomery | Central Alabama Refrigeration | 334-834-2222 | 334-834-4300 |
| ALASKA | | | |
| Anchorage | Polar Refrigeration | 907-349-3500 | 907-344-7053 |
| ARIZONA | | | |
| Phoenix | Andrews Refrigeration | 602-992-9560 | 602-992-9570 |
| ARKANSAS | | | |
| Little Rock | Scotts Refrigeration | 501-562-1863 | 501-562-2308 |
| CALIFORNIA | | | |
| Anaheim | Norms Refrigeration | 714-236-3600 | 714-236-0607 |
| Oxnard | Koolco Mechanical | 805-604-0309 | 805-604-0312 |
| Roseville | R&M Refrigeration | 916-784-3600 | |
| Salinas | Traboh Inc. | 831-758-6646 | 831-758-0791 |
| San Diego | San Diego Refrigeration | 858-270-5555 | 619-293-0870 |
| San Francisco | South City Refrigeration | 800-200-8256 | 650-588-7726 |
| Santa Rosa | California Refrigeration | 707-544-5313 | 707-545-6823 |
| Visalia | A.R.C. Comfort | 800-300-7700 | 559-627-2151 |
| COLORADO | | | |
| Denver/Ft Collins/Co. Springs | General Parts & Service | 800-892-0455 | 303-308-1723 |
| CONNECTICUT | | | |
| | Enviro Services | 781-444-5945 | 781-444-5948 |
| FLORIDA | | | |
| Jacksonville | Fournier Refrigeration | 904-260-0464 | 904-268-8065 |
| Jacksonville | Heritage Service Group | 904-264-1940 | 904-264-1947 |
| Lakeland - Tampa | Newberry's Refrigeration | 863-688-8871 | 863-683-2698 |
| Lantana | Excell Refrigeration | 561-585-0342 | 561-547-0069 |
| Melbourne | Market Refrigeration | 800-622-0426 | 321-951-4308 |
| Miami | All Phase | 305-235-7827 | 305-874-9314 |
| Orlando | Heritage Service Group | 407-316-8010 | 407-996-2760 |
| Pensacola | Heritage Service Group | 850-478-5533 | 850-478-7062 |
| Pompano Beach/S Florida | Heritage Service Group | 954-971-0456 | 954-977-7317 |
| Pompano Beach/S Florida | Prime Mechanical Services | 954-971-2444 | 954-971-2441 |
| Tallahassee | Premium Services | 850-668-8566 | 850-425-5776 |
| Tampa | Heritage Service Group | 813-620-1777 | 813-621-3339 |
| W Palm Beach | Smithco Refrigeration | 561-833-3793 | 561-832-9051 |

MASTER SERVICE AGENT LISTING

| STATE | COMPANY NAME | PHONE | FAX |
|--|--------------------------|--------------|--------------|
| GEORGIA | | | |
| (Jacksonville, FL) | Fournier Refrigeration | 904-260-0464 | 904-268-8065 |
| Atlanta | Heritage Service Group | 770-368-1465 | 770-368-2044 |
| Fayetteville | T&O Refrigeration | 770-461-5217 | 770-461-0569 |
| Macon | Metro Air | 478-788-3826 | 478-785-0358 |
| Savannah | Heritage Service Group | 912-965-9621 | 912-965-9622 |
| HAWAII | | | |
| Kaneohe | Shobu's Refrigeration | 808-479-5817 | 808-484-2221 |
| Maui | A&I Refrigeration | 808-877-7866 | 808-877-2126 |
| Oahu | Pacific Refrigeration | 808-488-5244 | 808-488-3845 |
| IDAHO | | | |
| Garden City | Boise Refrigeration | 208-344-0709 | 208-344-4457 |
| ILLINOIS | | | |
| Chicago/Rockford/NW IN | General Parts & Service | 800-880-3604 | 630-595-0006 |
| Urbana | Frosty Refrigeration | 217-367-7925 | 217-367-1058 |
| Wauconda | U.S. Refrigeration | 847-526-1099 | 847-526-9982 |
| INDIANA | | | |
| (Cincinnati, OH) | Commercial Parts Service | 800-837-2828 | |
| Indianapolis | Heritage Service Group | 317-544-4326 | 317-544-4327 |
| Indianapolis/Terre Haute/ Bloomington | General Parts & Service | 800-410-9794 | 317-290-8085 |
| Muncie | Turner Commercial Ref. | 765-288-5306 | 765-288-5363 |
| KANSAS | | | |
| Wichita | General Parts & Service | 866-211-5439 | 316-315-0660 |
| KENTUCKY | | | |
| (Cincinnati, OH) | Commercial Parts Service | 800-837-2828 | |
| Louisville | Heritage Service Group | 502-569-7722 | |
| Louisville | Platt Mechanical | 502-896-9886 | 502-491-0680 |
| Murray | Randy Thornton | 270-753-8181 | 270-753-2130 |
| LOUISIANA | | | |
| Baton Rouge | Eagle Refrigeration | 225-751-6912 | 225-751-6916 |
| Baton Rouge | Heritage Service Group | 225-667-8314 | 225-262-2692 |
| Harahan | Abear Refrigeration | 504-733-3600 | 504-733-3692 |
| Lake Charles | C&W Refrigeration | 337-474-4432 | 337-562-7999 |
| New Orleans | Heritage Service Group | 504-734-8864 | 504-733-2559 |
| Shreveport | Heritage Service Group | 318-636-2008 | 318-636-2122 |
| Shreveport | TD Refrigeration | 318-747-8844 | 318-226-1455 |
| MARYLAND | | | |
| Baltimore | EMR Service | 410-467-8080 | 410-243-2509 |
| MASSACHUSETTS | | | |
| Needham(Covers CT, MA, RI) | Enviro Services | 781-444-5945 | 781-444-5948 |
| MICHIGAN | | | |
| Ferndale | Penguin Refrigeration | 248-542-3158 | 248-542-3058 |
| Mid-Michigan | Swanson Food Equipment | 517-852-0779 | 517-852-0637 |
| Mount Pleasant | Heritage Service Group | 989-775-6560 | 989-775-6563 |
| New Hudson | Four Streams Services | 248-437-4400 | 734-786-1220 |
| Saginaw | Schroder Store Fixture | 989-233-2973 | 989-790-3008 |
| MINNESOTA | | | |
| Minneapolis | Heritage Service Group | 651-633-0400 | 651-697-7346 |
| Twin Cities/Rochester/St. Cloud | General Parts & Service | 800-279-9980 | 952-944-7101 |

MASTER SERVICE AGENT LISTING

| STATE | COMPANY NAME | PHONE | FAX |
|---|--------------------------------|--------------|--------------|
| MISSISSIPPI | | | |
| Gulfport | Geiger Heating & Air | 228-832-2465 | 228-832-1027 |
| Jackson | Heritage Service Group | 601-607-3340 | 601-607-3499 |
| Terry | Yates Refrigeration | 601-878-0130 | 601-878-2617 |
| MISSOURI | | | |
| Kansas City/Springfield/ St. Joseph/(Topeka, KS) | General Parts & Service | 800-279-9967 | 816-421-1270 |
| St. Louis, Chesterfield, St. Charles, Granite City | Commercial Services | 636-519-7000 | 314-965-9727 |
| NEBRASKA | | | |
| Omaha | Marking Refrigeration | 402-895-0255 | 402-895-6295 |
| Omaha (Serving Iowa) | General Parts & Service | 888-831-4031 | 402-408-9991 |
| NEVADA | | | |
| Las Vegas | Heritage Service Group | 702-558-3188 | 702-564-6804 |
| Las Vegas | JJ07 Refrigeration | 702-300-4823 | 702-233-0047 |
| State Line | Summit Refrigeration | 775-588-1288 | 775-562-2660 |
| NEW JERSEY | | | |
| Orange | Neil Sullivan & Associates | 973-678-2155 | 973-678-5728 |
| Paterson | Airtron | 973-684-5002 | 973-684-4130 |
| NEW MEXICO | | | |
| Albuquerque | Certified Service | 505-343-9934 | 505-343-9964 |
| NEW YORK | | | |
| Buffalo | Mesmer Refrigeration | 716-855-0575 | 716-855-3268 |
| College Point | All Service Refrigeration | 718-746-7965 | 718-746-6054 |
| New Hyde Park | Day & Nite Refrigeration | 516-719-8842 | 516-378-1735 |
| New York | Bev Service | 212-246-6588 | 212-246-6586 |
| New York | Enviro Services | 781-444-5945 | 781-444-5948 |
| New York | United Air | 845-561-5030 | 845-561-0038 |
| Rochester | Flower City Restaurant Service | 585-482-5890 | 585-482-5915 |
| Syracuse | ABC Refrigeration | 315-455-7083 | 315-455-5923 |
| NORTH CAROLINA | | | |
| Charlotte | Day & Nite Refrigeration | 803-746-7163 | 803-746-7164 |
| Charlotte | Freeman Refrigeration | 704-394-8234 | 704-394-0998 |
| Greensboro | Greensboro Refrigeration | 336-272-9361 | 336-272-8411 |
| Raleigh | Heritage Service Group | 919-481-3535 | 919-481-1470 |
| Winston-Salem | Cool Brew Refrigeration Svc | 336-785-1242 | 336-771-7313 |
| NORTH DAKOTA | | | |
| Bismarck | River City Refrigeration | 701-250-8300 | 701-250-8390 |
| Fargo | Dakota Refrigeration | 701-235-9698 | 701-235-5207 |
| Fargo | General Parts & Service | 800-279-9987 | 701-235-0539 |
| OHIO | | | |
| Cincinnati | Commercial Parts Service | 800-837-2828 | |
| Cleveland | Daly Refrigeration | 216-441-2323 | 216-441-1331 |
| Columbus | Commercial Parts Service | 614-221-0057 | 614-221-3622 |
| Dayton | Commercial Parts Service | 937-259-0091 | 937-259-0753 |
| OKLAHOMA | | | |
| Oklahoma City | Heritage Service Group | 405-228-0707 | |
| Oklahoma City | Hinton Refrigeration | 405-946-2766 | 405-946-2765 |
| OREGON | | | |
| Medford | Applied Refrigeration | 541-245-5513 | 541-245-4468 |
| Milwaukee | Key Mechanical | 503-231-0731 | 503-236-5848 |

MASTER SERVICE AGENT LISTING

| STATE | COMPANY NAME | PHONE | FAX |
|--|------------------------------|--------------|--------------|
| PENNSYLVANIA | | | |
| Allentown | Howard Refrigeration | 610-434-3877 | 610-434-2677 |
| Bridgeville | B.E. Refrigeration | 412-564-9000 | 412-564-9005 |
| Harrisburg | Hobart Sales & Service | 717-564-6202 | 717-564-2184 |
| Philadelphia | R.S. Sales & Service | 215-333-9200 | 215-333-8874 |
| State College | Berrera Refrigeration | 814-238-0238 | 814-238-8668 |
| RHODE ISLAND | | | |
| (Needham, MA) | Enviro Service | 781-444-5945 | 781-444-5948 |
| SOUTH CAROLINA | | | |
| Charleston | Aero Services | 843-747-4700 | 843-747-7059 |
| Charleston | Heritage Service Group | 877-428-1605 | 877-969-4576 |
| Columbia | Heritage Service Group | 803-865-5131 | 803-865-5524 |
| Greenville | Refrigeration Services | 864-292-0092 | 864-292-0611 |
| Lexington | Excell Refrigeration | 803-939-1914 | 803-939-7002 |
| Myrtle Beach | Heritage Service Group | 843-626-4209 | 843-626-1942 |
| Rock Hill | Day & Nite Refrigeration | 803-746-7163 | 803-746-7164 |
| SOUTH DAKOTA | | | |
| Rapid City | Al Cornella Refrigeration | 605-348-4684 | 605-348-5105 |
| Sioux Falls | Mulder Refrigeration | 605-338-1897 | 605-338-1820 |
| TENNESSEE | | | |
| Chattanooga | FESCO | 423-624-3381 | 423-624-3383 |
| Knoxville | FESCO | 865-522-5764 | 865-522-0982 |
| Knoxville | Heritage Service Group | 865-577-1004 | 865-577-8151 |
| Memphis | Heritage Service Group | 901-379-0900 | 901-379-0935 |
| Nashville | FESCO | 615-724-1118 | 615-724-1121 |
| Nashville | Heritage Service Group | 615-254-8688 | 615-254-8696 |
| Nashville | T&O Refrigeration | 770-461-5217 | 770-461-0569 |
| TEXAS | | | |
| Dallas/Fort Worth | Heritage Service Group | 817-831-1144 | 817-831-2324 |
| Dallas/Fort Worth/ Mesquite | R.S.I | 972-279-3800 | 972-331-2276 |
| Houston | Heritage Service Group | 713-839-0100 | 713-839-0115 |
| Houston | Houston North Refrigeration | 713-692-7702 | 281-389-4728 |
| San Antonio | Heritage Service Group | 210-921-1355 | 210-590-6792 |
| San Antonio | Heye Refrigeration | 210-226-7772 | 210-226-8228 |
| UTAH | | | |
| W Jordan | Michael's Commercial Service | 801-446-9299 | 801-446-1992 |
| VERMONT | | | |
| Essex Junction | KC Mechanical | 802-878-0800 | 802-878-7001 |
| VIRGINIA | | | |
| Ashland | Central Ice | 804-550-7860 | 804-550-7861 |
| Manassas Park | Nationwide Refrigeration | 703-330-7500 | 703-330-1945 |
| Norfolk | Heritage Service Group | 757-545-2145 | 757-545-2146 |
| Richmond | Heritage Service Group | 804-501-0890 | 804-501-0891 |
| WASHINGTON | | | |
| Seattle | Seattle Refrigeration | 206-762-7740 | 206-762-1730 |
| WEST VIRGINIA | | | |
| Charleston | Heritage Service Group | 304-941-0055 | 304-941-0056 |
| WISCONSIN | | | |
| Milwaukee/Green Bay/ Wausau/Rhineland/Madison | General Parts & Service | 800-279-9976 | 262-650-6660 |

WARRANTY AND TERMS

Standard Limited Warranty

Structural Concepts Standard limited warranties:
One-year parts/one year labor/five year motor compressor.

Parts-One Year: Structural Concepts warrants to the original purchasers, the equipment manufactured by it to be free from defects in material and workmanship under normal use and service within 12 months from the date of original shipment from the factory.

Any items returned to the factory must be authorized by Structural Concepts Technical Service Department and be shipped prepaid. Replacements will be shipped collect.

This warranty does not include any material, which has been subject to misuse, neglect, damage in transit, accident, negligence, or alteration.

Labor-One Year: Structural Concepts warrants to the original purchasers, the equipment manufactured by it. Structural Concepts will for a period of 12 months from the date of original shipment from the factory pay the cost of labor for repairs and replacement of parts that it has determined to be defective.

This warranty does not include the cost of labor for initial installation, start-up, correction of improper installations, misapplications, repair caused by abuse and negligence, modifications, normal adjustments, drive time to and from repair site, and freon recovery. The cost of service labor reimbursed will be based on straight-time rate and reasonable time for the repair of defect.

All service labor charges are subject to approval by Structural Concepts Technical Service Department. Contact your Master Service Agent. (See pages 80-83)

Motor-Compressor-Five Year: Structural Concepts warrants to the original purchasers that it will repair or exchange at our option, at any time during the five years following the date of original shipment from the factory a motor-compressor assembly of like design and capacity if the motor-compressor assembly or any part thereof is returned prepaid to nearest authorized jobber and is proved to our satisfaction to be inoperative due to defects in material or factory workmanship.

This warranty applies to the original motor compressor only.

The term "motor-compressor assembly" consists of the stator, rotor, eccentric rod, eccentric shaft piston, wrist pin, suction valve, discharge valve, and the cast housing in which these parts are enclosed.

This warranty does not apply to any electrical controls, condenser, evaporator, fan motors, overload switch, starting relay, temperature control, dryer, accumulator, or wiring harnesses after the first year. No claims can be made against this warranty for spoilage of product. Replacement of the motor-compressor assembly must receive a prior approval from Structural Concepts Technical Service Department.

This warranty does not apply to compressors furnished by Structural Concepts that are remote from the case.

General Conditions: Structural Concepts recommends that the installation, inspection, and start-up of refrigeration equipment be performed by a qualified refrigeration technician.

Structural Concepts makes no other expressed or implied warranty, and no person or representative of the seller is authorized to add to the seller's liabilities in connection with its products other than what is expressed.

These warranties do not apply to remote (compressor supplied by others) motor compressor applications.

Warranties listed here are for equipment located inside the continental United States and Canada.

All claims must contain the following information:

- The model and serial number of the equipment.
- The date of the equipment failure and place of installation.
- The name and address of the agency that performed the service work.
- A complete description of the equipment failure, circumstances relating to that failure, parts replaced and itemized list of all labor charges incurred.

Structural Concepts shall not be liable for any default or delay in performance caused by any contingency beyond its control.

Warranties do not include any food or business loss and transportation charges to or from Structural Concepts factory.

Condenser coils must be cleaned at regular intervals. Failure to do so can cause compressor malfunction and will void warranty. Cases are designed to operate in an environment of 75° F ambient and 55% relative humidity.

Structural Concepts Terms Of Sale

1. **PRICES.** This price list supersedes all other price lists. Structural Concepts reserves the right to change the price of equipment without notice. All quotations for equipment shall be void if not accepted within 30 days.
2. **DELIVERY.** Shipping or delivery date is approximate. Seller will not be liable for failure to deliver due to strikes, suppliers' delays, changes requested by Buyer or any causes beyond its control.
3. **SHIPMENT.** When possible, Buyer's requested delivery carrier will be used. Structural Concepts, however, reserves the right to ship via any responsible carrier. Shipping charges are payable by the consignee and any claims arising as to such charges must be resolved between the carrier and consignee.
4. **DAMAGE.** Claims for damage in transit must be made by the consignee with the carrier. Structural Concepts assumes no responsibility for damages while in transit.
5. **TAXES.** Federal, state, city sales or use taxes are not included with these prices.
6. **CANCELLATIONS.** Buyer may cancel its order, reduce quantities, revise specifications or extend schedules only by mutual agreement with Seller. Reasonable and proper cancellation charges will apply. These charges shall take into account expenses already incurred and commitments made by Seller on behalf of the Buyer's order.
7. **RETURNED GOODS.** No product may be returned unless authorized by Structural Concepts corporate office. If return of product is authorized, consignee shall be required to pay a restocking and/or handling charge. Product must be returned freight prepaid and have not been used. Product must be received by Seller in the same condition as originally shipped.

FACTORY CONTACT INFORMATION



Structural Concepts Corporation
888 E. Porter Road
Muskegon, MI 49441

Toll-Free 800-433-9489
Phone 231-798-8888
Fax 231-798-4960

www.structuralconcepts.com



Customer Support

Western States

Christine Clark - *Customer Service Rep*
800-433-0142 Extension 1
cclark@structuralconcepts.com

David Faoro - *Technical Service Rep*
800-433-0142 Extension 2
dfaoro@structuralconcepts.com

Eastern States

Janell Yonker - *Customer Service Rep*
800-433-0103 Extension 1
jyonker@structuralconcepts.com

Tom Wernstrom - *Technical Service Rep*
800-433-0103 Extension 2
twernstrom@structuralconcepts.com

Sales

Terry A. Hoelle, CFSP
National Sales Manager - *Foodservice Division*
231-798-6237
thoelle@structuralconcepts.com

Rod Herrington
Eastern Region Sales Manager - *Foodservice Division*
231-798-6345
rherrington@structuralconcepts.com

Jeff Schneider
VP Sales & Marketing
231-798-6258
jschneider@structuralconcepts.com



Structural
Concepts

888 E. Porter Road
Muskegon, MI 49441

www.structuralconcepts.com

Toll-Free 800-433-9489
Phone 231-798-8888
Fax 231-798-4960

