

## C1030 – 1000 lb Cube Ice Machine

### Prodigy™ Modular Cube Ice Maker



Shown on BH801S-A bin.

### Features

Prodigy™ cubers use **significantly less energy and water** than other cube ice machines, exceeding pending California and Federal energy efficiency regulations.

**Auto-Alert™ indicator lights** constantly communicate about operating status and actually signal your staff when it's time to descale, sanitize, and more—making upkeep practically foolproof.

The patented **WaterSense™ adaptive purge control** delivers maximum reliability by reducing scale buildup for a longer time between cleanings.

**Preventative maintenance is simpler** than ever with easily-removed panels allowing clear access to internal components and a diagnostic code display insuring the right fix the first time. Reusable air filter is easily removable from the outside.

All external panel components are crafted for **optimal aesthetic appeal** through superior fit and finish.

An optional **advanced feature SmartBoard™** provides NAFEM data protocol and additional operational data that can be displayed on-screen or transmitted remotely, resulting in early alert and fast diagnosis of operating issues.

An optional **Vari-Smart™ ultrasonic ice level control** sensor allows you flexibility to program ice levels, for up to 7 days, keeping just the right amount of freshly made ice in the bin.

### 24 Hour Volume Production

Air Cooled		Remote		Water Cooled	
70°F/21°C 50°F/10°C lb/kg	Air Water	ARI 90°F/32°C 70°F/21°C lb/kg	70°F/21°C 50°F/10°C lb/kg	Air Water	ARI 90°F/32°C 70°F/21°C lb/kg
1077/490		844/384	996/453	851/387	1009/459
					908/413



### Modular Bin Options

\* Stainless Steel with Galvanized Back & Bottom.

Model Number	Dimensions W" x D" x H"	ARI Certified Bin Capacity lb/kg	Application Capacity lb/kg	Finish	Ship Weight lb/kg
B842S	42 x 34 x 44	610/277	778/353	SS	185/84
B948S	48 x 34 x 44	700/319	893/406	SS	220/100
BH1100BB	48 x 34 x 50	860/390	1100/499	SS w/ GBB*	280/127
BH1100SS	48 x 34 x 50	860/390	1100/499	SS	280/127



Bin: BH1100SS

### Cube Ice



Small Cube  
3/8" x 3/8" x 3/8"  
(2.22 x 2.22 x .95 cm)

Medium Cube  
7/8" x 7/8" x 7/8"  
(2.22 x 2.22 x 2.22 cm)

Common ice form, ideal for mixed drinks.

### Warranty

- 3 years parts and labor on all components.
- 5 years parts and labor on the evaporator.
- 5 years parts on the compressor and condenser.

Warranty valid in North, South & Central America.  
Contact factory for warranty in other regions.

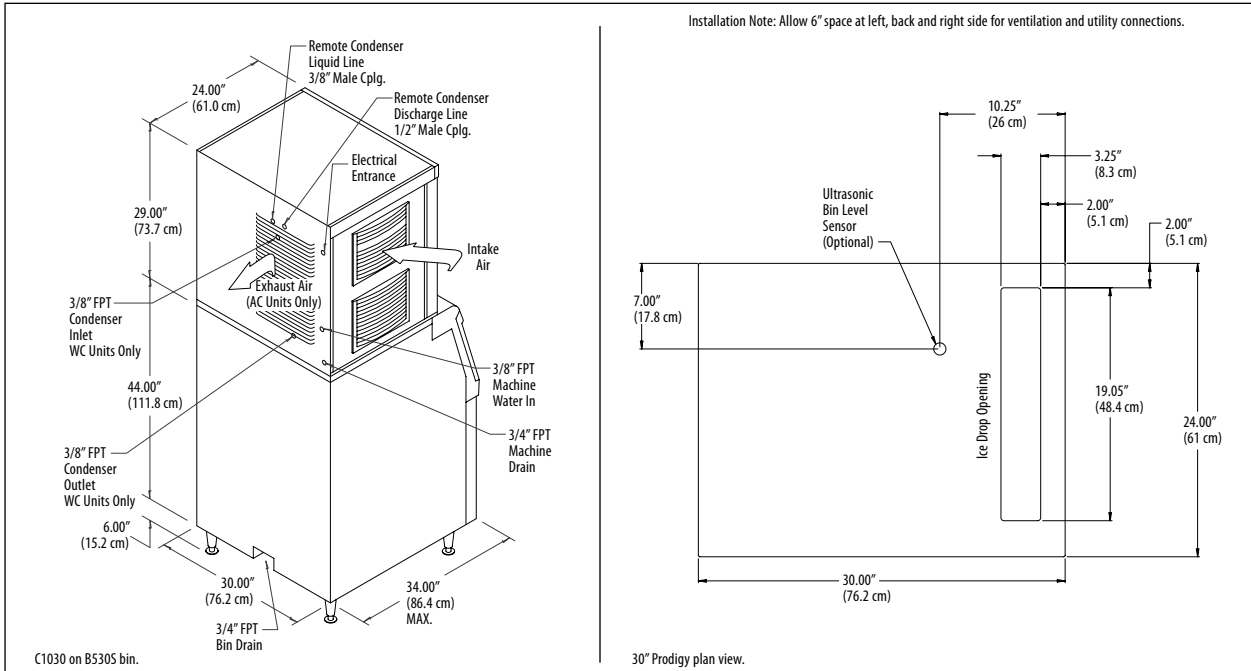

## Specifications

Model Number* <small>Cube Size: medium or small</small>	Condenser Unit	Basic Electrical Volts/Hz/Phase	Max. Fuse Size or HACR Circuit Breaker (amps)	Circuit Wires	Min. Circuit Ampacity	Energy Consumption kWh/100 lb (45.4 kg) 90°F(32°C)/70°F(21°C)	Water Usage Gallons/100 lb (liters/45.4 kg)	
							Potable 90°F(32°C)/ 70°F(21°C)	Condenser 90°F(32°C)/ 70°F(21°C)
pair C1030MA-32A	Air	208-230/60/1	20	2	16.0	5.0	18.4/69.8	-
	Remote	208-230/60/1	20	2	15.8	5.0	18.2/69.0	-
	Water	208-230/60/1	15	2	14.8	4.0	19.7/74.7	153.0/580.1
unit C1030SA-32A	Air	208-230/60/1	20	2	16.0	5.0	18.4/69.8	-
	Remote	208-230/60/1	20	2	15.8	5.0	18.2/69.0	-
	Water	208-230/60/1	15	2	14.8	4.0	19.7/74.7	153.0/580.1

\* 208-230/60/3 Voltage - Substitute "-3" in place of "-32", i.e. C1030SA-3A.

## All Models

Dimensions (W x D x H):

Unit:  
30" x 24" x 29"  
(76.2 x 61.0 x 73.7 cm)

Shipping Carton:  
33.5" x 27.5" x 34"  
(85.1 x 69.9 x 86.4 cm)

Shipping Weight:  
235 lb / 107 kg

BTUs per hour:  
16,200

## Accessories

Model Number	Description
KVS	Vari-Smart™ Ice Level Control - Program ice bin levels to match ice needs.
KSB	Smart-Board™ Advanced Control - Use additional operational data for fast diagnosis.
KSB-N	Smart-Board™ Advanced Control with Network - Network capable.
ERC311-32A	Remote Condenser for C1030xR, 208-230/60/1 - Consult Remote Condenser Spec Sheet for details.
RTE10	Line set, Precharged, R-404A, 10ft.
RTE25	Line set, Precharged, R-404A, 25ft.
RTE40	Line set, Precharged, R-404A, 40ft.
RTE75	Line set, Precharged, R-404A, 75ft.

\* Scotsman recommends all ice machines have water filtration. See Scotsman Sanitation Matrix for details.

## Operating Requirements

	Minimum	Maximum
<b>Air Temperatures</b>	50°F (10°C)	100°F (38°C)
<b>Water Temperatures</b>	40°F (4.4°C)	100°F (38°C)
<b>Remote Cond. Temps</b>	-20°F (-29°C)	120°F (49°C)
<b>Water Pressures</b>	20 PSIG (1.4 bar)	80 PSIG (5.5 bar)
<b>Electrical Voltage</b>	-5%	+10%

Specifications and design are subject to change without notice.

Scotsman Ice Systems  
775 Corporate Woods Parkway  
Vernon Hills, IL 60061

1-800-SCOTSMAN  
Fax: 847-913-9844  
E-mail: [customer.service@scotsman-ice.com](mailto:customer.service@scotsman-ice.com)

[www.scotsman-ice.com](http://www.scotsman-ice.com)



# SCOTSMAN

LARGE MODULAR ICE STORAGE BINS



Bin includes 6" legs w/ adjustable leveling.

**B H 1 1 0 0**

**B H 1 3 0 0**

**B H 1 6 0 0**

## VOLUME STORAGE – AMPLE ICE RESERVE

- BH1100 – Holds up to 1100 lbs. of ice
- BH1300 – Holds up to 1400 lbs. of ice
- BH1600 – Holds up to 1775 lbs. of ice

## QUALITY CONSTRUCTION

- All models available with all stainless steel construction or stainless steel with galvanized back and bottom.
- Features a roto-molded pouch door that is dent and scratch resistant. Provides excellent thermal break and doesn't sweat.
- The pouch style door can be installed without tools in less than 5 minutes.
- Pouch style door is shipped inside bin to provide a narrower bin for delivery through doorways.
- Adjustable bin top filler panels included for use with most Scotsman ice machines (See table on back for configurations requiring special bin tops).
- NSF approved construction.

## WARRANTY *See Dealer for complete warranty details .*

- 5 years parts and labor on all components.

CERTIFIED  
**ISO**  
9001:2000



 **Scotsman**<sup>®</sup>

# Bin Specifications

## 1100 UPRIGHT

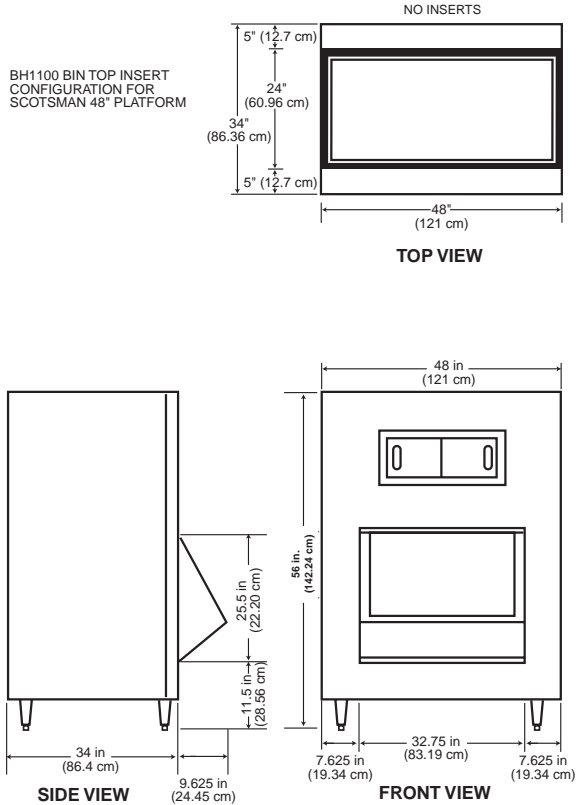

Drain: 1" FPT drain fitting

## 1300/1600 UPRIGHT

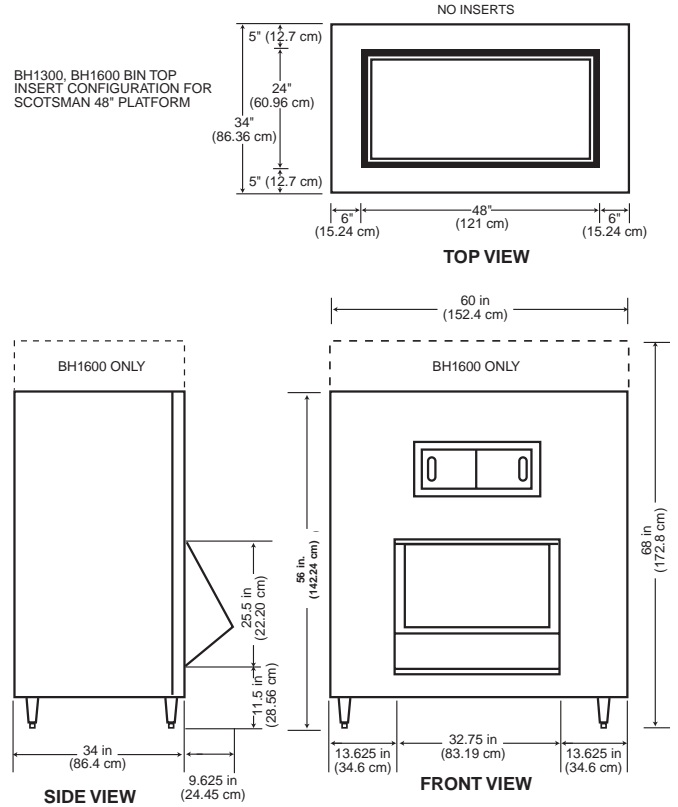

SCOTSMAN MODULAR BIN			Certified & rated in accordance with ARI standard 820-95		
Model Number	Dimensions W"xD"xH" *	ARI Bin Capacity lbs./kg.	Application Capacity lbs./kg.	Finish **	Ship Weight lbs./kg.
BH1100	48" x 34" x 50"	860/393	1100/499	SS OR BB	280/127
BH1300	60" x 34" x 50"	1100/499	1400/635	SS OR BB	310/140
BH1600	60" x 34" x 62"	1375/624	1755/796	SS OR BB	370/168

\* Add 6" height for legs.

\*\* SS - All Stainless Steel with Polyethylene Liner  
BB - All Stainless Steel Except Galvanized Back and Bottom

Adjustable Bin Top filler panels are included for use with most Scotsman Ice Machines.  
See table to right for exceptions.  
Please contact your Scotsman representative to order the correct bin top for those configurations.

ARI storage capacity for bins is based on 80% of total volume in cubic feet x 30 lb./ft.<sup>3</sup> average density of ice.  
Application capacity for bins is based on 90% of total volume in cubic feet x 34 lb./ft.<sup>3</sup> average density of ice.

Scotsman's ice machines and bins are not designed for outdoor installations.  
Specifications and design are subject to change without notice.

Consult Your Local SCOTSMAN Representative At:

Configurations Requiring Special Bin Tops			
	BH1100	BH1300	BH1600
CME686	ALWAYS		
CME810	ALWAYS		
CME656	WHEN STACKED	WHEN STACKED OR SIDE BY SIDE	
CME806		WHEN STACKED OR SIDE BY SIDE	
CME1056		WHEN STACKED OR SIDE BY SIDE	
CME1386	NONE REQUIRED	WHEN SIDE BY SIDE	
CME1686		WHEN SIDE BY SIDE	
CME2086		WHEN SIDE BY SIDE	
CME1356	NONE REQUIRED	WHEN STACKED	
CME1656		WHEN STACKED	
CME2006		WHEN STACKED	
MAR1400/2000	ALWAYS		

**YOU'LL VALUE THE DIFFERENCE™**

75 Corporate Woods Parkway • Vernon Hills, IL 60061 • 1-800-SCOTSMAN • Fax: (847) 913-9844  
visit our website at: [www.scotsman-ice.com](http://www.scotsman-ice.com) • E-mail: [customer.service@scotsman-ice.com](mailto:customer.service@scotsman-ice.com)

 **Scotsman®**