

Snapshot

The OptiPure® OP175/16 water treatment system utilizes reverse osmosis (RO) to remove >97% of the total dissolved solids (TDS) from water. Then a balance of minerals is dissolved into the RO water to provide desirable “Optimized” water TDS. The system operates at line pressure and can produce up to 175+ gallons per day of optimal quality water. The OP175/16 is a complete system that includes integrated pre-filtration with particulate and chlorine reduction, reverse osmosis and mineral addition in a space saving, wall-mount or undercounter design. A built-in full system bypass valve and sample port assures no service interruption and simplifies routine maintenance. Also included is a 16 gallon atmospheric storage tank with a top-mounted variable-flow repressurization system and a sub-micron air breather. Hose, tubing and fittings required for installation are included.

System Benefits

- Virtually eliminates scale problems related to high TDS & water hardness and reduce the potential for corrosion related to water chemistry.
- Integrated Mineral Addition cartridge adds desirable TDS to provide balanced, buffered Optimized water.
- High capacity parallel pre-filtration protects the RO membrane and assures consistent performance for up to one year between pre-filter replacements.
- Compact, Modular Design enables installation under counters and in very tight spaces.
- Maximize equipment operating and energy efficiency.
- Dual-read digital TDS meter provides push-button monitoring of membrane performance and optimized water quality.
- Sample Port allows quick and simple system checks and adjustments.
- Built-in pressure gauge allows visual monitoring of operating pressure.
- Integrated system bypass valve eliminates down-time or service interruptions.
- All consumables are easy-to-change Qwik-Twist cartridges.
- Simple, easy-to-service and maintain design.

ITEM #: _____ QTY: _____
JOB NAME/NUMBER _____



Application

Any foodservice equipment where it is desirable to remove existing TDS (total dissolved solids) and provide a consistent balance of buffered TDS to minimize problems associated with high TDS, high hardness, high chlorides or any other TDS-related problems.

Installation Tips

- Feed-water connection to system should be COLD only.
- Do not exceed system specifications for temperature and pressure.
- Provide a dedicated 1/2" water line to the unit for consistent flow and pressure to the system.
- Allow 3" clearance below system for filter cartridge removal and replacement.
- Connect filtered water line to steam production connections only. Do not use for condenser water.
- Detailed installation, operation & maintenance manual is included with each system.
- Mount the OP175/16 where it can be easily serviced.

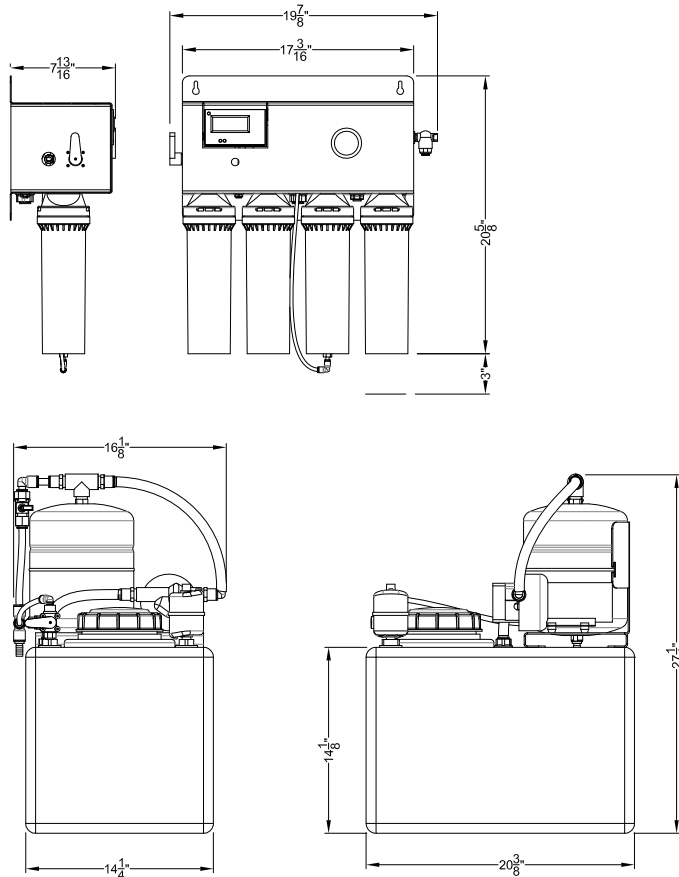

Feed-Water Chemistry

Feed TDS	Up to 1200 ppm
Feed pH	6-10
Hardness*	12 grains or less
Free Chlorine	<2 mg/l
Iron	0.1 mg/l max
Turbidity	0.05 NTU
Manganese	0.05 mg/l max
Hydrogen Sulfide	0.0 mg/l

*For water outside of these parameters call OptiPure technical service.

Note: Repressurization Pump/Buffer Tank Stand Assembly can be removed from top of tank and placed on floor or shelf in close proximity of the tank. Use Remote Kit PN: 164-89116.

Specifications

System		
Dimensions	Processor Tank	20.6"hx19.9"wx7.8"d 27.3"hx16.1w"x20.4"l.
Connection - Feedwater		3/8" Push Fit Tubing
Operating Pressure Range		60-85 psi at 0.5 gpm (3.5 -5.9 bar)
Inlet Water Temperature Range		40° -100° F (4° -38° C)
Shipping Weight		25 lbs.
Drain Connection (Within 5' of unit)		2 GPM Minimum Flow
Performance		
Typical TDS* Rejection		97+%
Product Water Production (at 77°F, 60psi)		175+ gals/day 7.29 gals/hr 0.122 gpm
		<i>Production rate is strictly dependent on feed water temperature and pressure.</i>
Typical Optimized Water TDS		40-80 ppm

Replacement Media

Description	Part Number	Qty
CTO-Q10 Pre-Filters	300-05828	2
AMS-QT15 Membrane	204-52820	1
MA-Q10 Post-Treatment	300-05850	1

It is recommended that Pre-Filter be changed every 6 months, when capacity is reached or when feedwater pressure or flow becomes inadequate. Membrane life varies depending on feedwater conditions and PreFilter maintenance. 12-18 months under typical conditions but it can be as long as 3-5 years.

Options

Description	Part Number
ScaleX2 Pre-Treatment	160-52101
QTPT-1 CTO Post-Treatment*	160-52120
BPA200 Booster Pump Assembly	164-85015
FXPT-11CR Chloramine Reduction System	160-50011
PRV- Pressure Reducing Valve	164-89938

This product is for commercial use only and must be installed and maintained according to manufacturers guidelines.

Do not use on water that is microbiologically unsafe or of unknown quality without adequate disinfection before or after the system.

Warranty

Systems have a 1 year warranty against defects in material and workmanship. Warranty does not include filters or membranes. For complete warranty information contact OptiPure customer service or go to the OptiPure website.

OP175_16specRev0

Dealer/Distributor Info:

Mfg. by OptiPure div. of Procam Controls, Inc.
2605 Technology Dr., Bldg 300 Plano, TX 75074
p: 972.881.9797; f: 972.422.6262
e: info@optipure.net www.optipurewater.com