

QMPM-48

QMPM SERIES

Quantum Series Medium Temp Open Display Merchandisers

MODELS

- QMPM-36
- QMPM-48
- QMPM-72

FEATURES

CONSTRUCTION

- 24 gauge white painted galvanized steel interior and exterior
- Removable two-tier stainless steel display deck
- Full length 8³/₄" wide laminated white formica counter top
- Automatic defrost
- On/off power switch (QMPM-36 and QMPM-48 only)
- Cord and plug (QMPM-36 and QMPM-48 only)
- 1" black vinyl front bumper guard
- 1⁵/₈" foamed-in-place "zero ODP" urethane insulation
- Electric condensate evaporator

FINISH

- White enamel interior and exterior

REFRIGERATION

- Refrigerant: R-134a
- Front air intake and rear discharge
- Electric condensate evaporator
- Forced air ducted flow
- Self-contained, bottom mount refrigeration system
- Temperature range: 34° to 41°F (1° to 5°C)
- R-factor (insulation efficiency rating): 14.01

WARRANTY

- Standard limited four year extended compressor and one year limited parts and labor

OPTIONS

- Custom exterior colors
- Night curtain kit
- Light kit
- Night curtain/light kit
- Casters
- Sandwich racks
- Sandwich rack dividers
- Custom bumper colors: Black (standard), blue, brown, green, red, white



QMPM SERIES

QUANTUM SERIES MEDIUM TEMP OPEN DISPLAY MERCHANDISERS

TECHNICAL SPECIFICATIONS

| MODEL | DIMENSIONS (in.) | | | DIMENSIONS (mm) | | | VOLTS | AMPS | UNIT H.P. | CAP. CU. FT. | SHIP CU. FT. | SHIP WT. (LB/KG) |
|---------|------------------|----|--------|-----------------|-----|------|----------|------------|-----------|--------------|--------------|------------------|
| | L | D | H | L | D | H | | | | | | |
| QMPM-36 | 36 | 31 | 43 1/4 | 914 | 775 | 1099 | 115 | 10.3 | 1/3 | 3.7 | 42.0 | 310/141 |
| QMPM-48 | 48 | 31 | 43 1/4 | 1219 | 775 | 1099 | 115 | 15.5 | 1/2 | 5.1 | 54.0 | 410/220 |
| QMPM-72 | 72 | 31 | 43 1/4 | 1829 | 775 | 1099 | 115/115* | 15.8/10.4* | 3/4 | 7.9 | 87.0 | 610/277 |

*Electric condensate evaporator requires separate power supply.

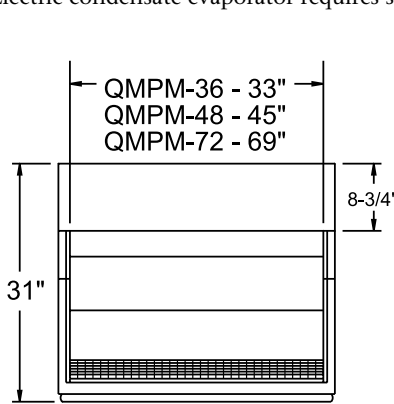

PLAN VIEW

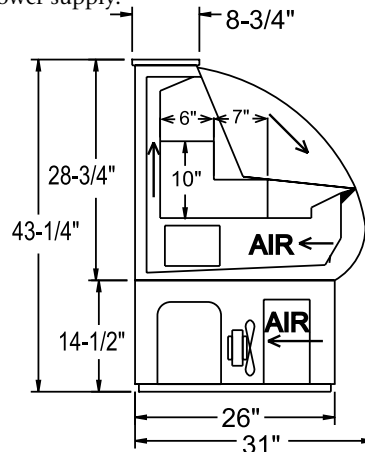

SIDE VIEW

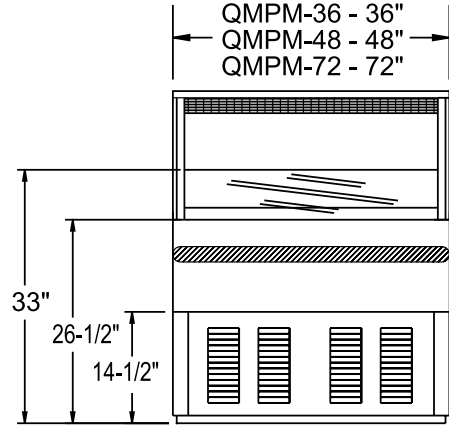

ELEVATION VIEW

LISTINGS



HOOKUP

QMPM-36 and QMPM-48 via plug in, 9 foot long, flexible 3 wire 14/3 cord with molded plug. QMPM-72 model hardwired with separate 115V junction boxes for cabinet and condensate evaporator.

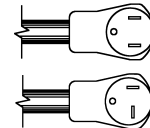

NEMA 5-15P (QMPM-36)

NEMA 5-20P(QMPM-48)

RECOMMENDED OPERATING CONDITIONS

- Merchandisers designed to hold product in the 34° to 41°F (1° to 5°C) range
- Designed to operate in air-conditioned stores where the maximum temperature is 75°F and the maximum relative humidity is 55%
- Should not be installed in direct sunlight
- Should not be installed near HVAC vents, fans or doorways that will disrupt airflow and compromise the function of the air screen inside the case
- Bottom shelf should not be loaded such that the front air intake is obstructed
- Factory installed controls should not be altered, removed or replaced without consent of the factory
- Product must not be displayed in the cold air curtain

BID SPECIFICATIONS

Item no. QMPM-_____
 Provide _____ () Quantum Series Medium Temp Open Display Merchandiser(s), Master-Bilt model no. QMPM-_____.
 Merchandiser to have removable two-tier stainless steel display deck, full length

8 3/4" wide laminated white formica counter top, automatic defrost, on/off power switch (QMPM-36 and QMPM-48 only), 1" vinyl front bumper guard and have foamed-in-place "zero ODP" urethane insulation. The refrigeration system is to be self-contained, have a front condenser air

intake and rear discharge and use R-134a refrigerant. The temperature range will be 34° to 41°F (1° to 5°C). Merchandiser to have standard limited four year extended compressor warranty and one year limited parts and labor warranty. Merchandiser to be UL and C-UL listed and UL EPH classified.

NOTE: All specifications subject to change without notice.



908 Highway 15 North • New Albany, MS 38652
 PHONE: 800-647-1284 or 662-534-9061 • FAX: 800-232-3966 or 662-534-6049 • www.master-bilt.com

