



TRUE FOOD SERVICE EQUIPMENT, INC.

St. Charles Industrial Center • P.O. Box 970 • O'Fallon, Missouri 63366
 (636)240-2400 • FAX (636)272-2408 • (800)325-6152 • www.truemfg.com
 Parts Dept. (800)424-TRUE • Parts Dept. FAX# (636)272-9471

Project Name: _____

A/A #

Location: _____

Item #: _____ Qty: _____

SIS #

Model #: _____

Model:
TBB-2

Back Bar Cooler:
Solid Door



TBB-2

- ▶ True's refrigerated back bar coolers are designed with enduring quality and value. Our commitment to using the highest quality materials and oversized refrigeration assures colder product temperatures and years of trouble free service.
- ▶ Oversized, factory balanced, refrigeration system holds 33°F to 38°F (.5°C to 3.3°C).
- ▶ Exterior - all stainless steel countertop, heavy duty, wear resistant laminated black vinyl front and sides, matching black aluminum back.
- ▶ Interior - 300 series stainless steel floor with 1/2" (13 mm) reinforced lip and heavy gauge galvanized steel walls. NSF approved for pre-packaged and bottled product.
- ▶ Positive seal doors.
- ▶ Entire cabinet structure and solid doors are foamed-in-place using high density, CFC free, polyurethane insulation.

ROUGH-IN DATA

Specifications subject to change without notice.
 Chart dimensions rounded up to the nearest 1/8" (millimeters rounded up to next whole number).

Model	Doors	Capacity		Shelves	Cabinet Dimensions (inches) (mm)			HP	Voltage	Amps	NEMA Config.	Cord Length (total ft.) (total m)	Crated Weight (lbs.) (kg)
		1/2 Barrels	12 oz. Cans		L	D	H						
TBB-2	2	2	134 6-pks	4	58 ⁷ / ₈ 1496	27 ¹ / ₈ 689	37 940	1/3 1/3	115/60/1 230-240/50/1	8.5 4.2	5-15P ▲	7 2.1	325 148

▲ Plug type varies by country.

1/06 Printed in U.S.A.

APPROVALS:

AVAILABLE AT:

Model:
TBB-2

Back Bar Cooler:
Solid Door



STANDARD FEATURES

DESIGN

- True's refrigerated back bar coolers are designed with enduring quality and value. Our commitment to using the highest quality materials and oversized refrigeration assures colder product temperatures and years of trouble free service.

REFRIGERATION SYSTEM

- Factory engineered self-contained, capillary tube system using environmentally friendly (CFC free) 134A refrigerant.
- Extra large evaporator coil balanced with higher horsepower compressor and large condenser; maintains cabinet temperatures of 33°F to 38°F (.5°C to 3.3°C).
- Sealed, cast iron, self-lubricating evaporator fan motor and larger fan blades give True merchandisers a more efficient low velocity, high volume airflow design. This unique design insures faster temperature pull down of warm product, colder holding temperatures and faster recovery in high use situations.
- Condensing unit accessed from behind front grill, slides out for easy cleaning and maintenance.

CABINET CONSTRUCTION

- Exterior - heavy duty, wear resistant laminated black vinyl front and sides, matching black aluminum back. All stainless steel counter top.

- Interior - 300 series stainless steel floor with 1/2" (13 mm) reinforced lip and heavy gauge galvanized steel walls.
- Insulation - entire cabinet structure is foamed-in-place using high density, CFC free, polyurethane insulation.
- Welded, heavy duty galvanized base rail dipped in rust inhibiting paint for corrosion protection inside and out.

DOORS

- Wear-resistant laminated black vinyl exterior with heavy gauge galvanized steel liner.
- Positive seal doors.
- Doors fitted with 12" (305 mm) long recessed handles that are foamed-in-place with a sheet metal interlock to insure permanent attachment.
- Magnetic door gaskets of one piece construction, removable without tools for ease of cleaning.
- Door locks standard.

SHELVING

- Four (4) adjustable, heavy duty, black PVC coated wire shelves. Two (2) left door dimensions are 32" L x 21 1/4" D (813 mm x 540 mm). Two (2) right door dimensions are 20 3/4" L x 21 1/4" D (528 mm x 540 mm). Four (4) chrome plated shelf clips included per shelf.
- Aluminum shelf support pilasters. Shelves are adjustable on 1/2" (13 mm) increments.

LIGHTING

- Fluorescent interior lighting.

MODEL FEATURES

- Evaporator is epoxy coated to eliminate the potential of corrosion.
- Listed under NSF-7 for the storage and/or display of packaged or bottled product.

ELECTRICAL

- Unit completely pre-wired at factory and ready for final connection to a 115/60/1 phase - 15 amp dedicated outlet. Cord and plug set included.



115/60/1
NEMA-5-15R

OPTIONAL FEATURES/ACCESSORIES

Upcharge and lead times may apply.

- 230-240V/50 Hz.
- 6" (153 mm) standard legs.
- 6" (153 mm) seismic/flanged legs.
- 2 1/2" (64 mm) diameter castors.
- 4" (102 mm) diameter castors.
- Wine racks.
- Wine or one (1) Liter beer organizers.
- 12 oz. beer bottle organizers.
- Remote cabinets (condensing unit supplied by others; system comes standard with 404A expansion valve and requires R404A refrigerant), consult factory technical service department for BTU information.

PLAN VIEW

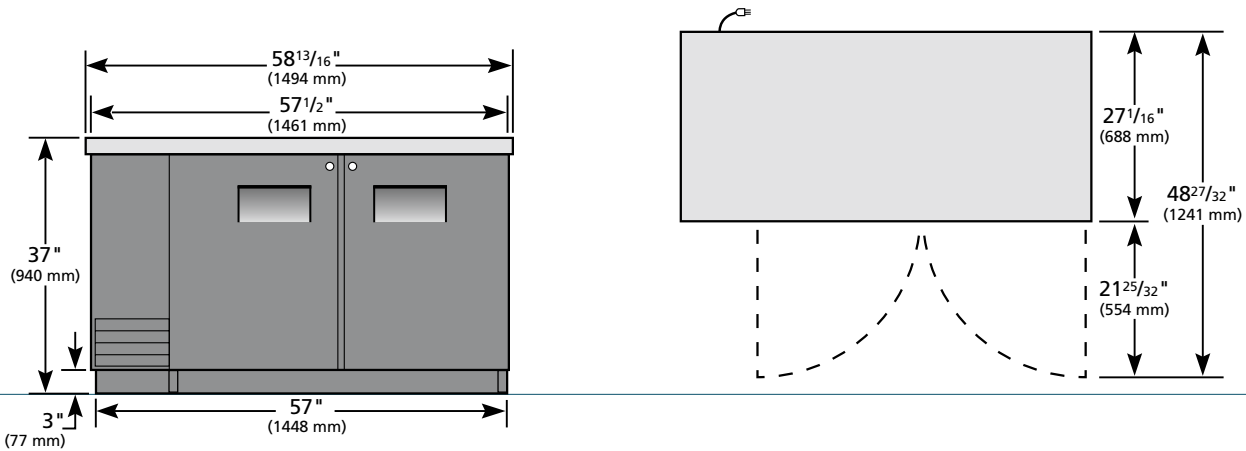

ELEVATION

PLAN VIEW

WARRANTY
One year warranty on all parts & labor and an additional 4 year warranty on compressor. (U.S.A. only)

METRIC DIMENSIONS ROUNDED UP TO THE NEAREST WHOLE MILLIMETER
SPECIFICATIONS SUBJECT TO CHANGE WITHOUT NOTICE



Model	Elevation	Right	Plan	3D
TBB-2	TFJY04E	TFJY04S	TFJY04P	TFJY043

TRUE FOOD SERVICE EQUIPMENT