

Stationary Standby Electric Generator - 25,000 WATTS

IMPORTANT SAFETY INSTRUCTIONS – Please make certain that persons who are to install, operate and maintain this equipment thoroughly read and understand these instructions prior to operation. **SAVE THESE INSTRUCTIONS** – This manual contains important instructions that should be followed during installation and maintenance of the generator and battery.

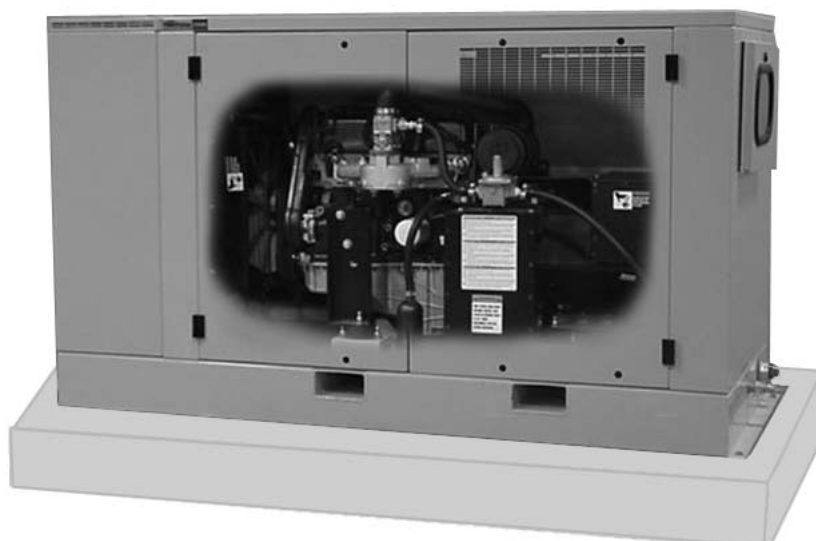

ENGLISH	➤	PP. 1-32
FRANCAIS	➤	pág. 33-52
ESPAÑOL	➤	p. 53-72

⚠ WARNING: Read and understand all safety precautions in this manual and other manuals included with this product before installing, operating and maintaining this equipment. Failure to comply with instructions in this manual could result in personal injury, property damage, and/or voiding of your warranty. Coleman Powermate **WILL NOT** be liable for any damage because of failure to follow these instructions.

Record the model and serial numbers of your generator below:

Model Number

Serial Number

Date Purchased

HELPLINE 1-800-445-1805

TABLE OF CONTENTS

Table of Contents	2
General Safety Instructions	3-4
Introduction	5
Unpacking Instructions	5
Specifications	6
Generator	6
Engine	6
Fuel	6
Dimensions	6
Installation Drawing	7
Installation	8
Location and Generator Placement	8-9
Fuel Selection	10
Natural Gas Settings	10
Liquid Propane Vapor Settings	10
Carburetor Adjustments	10
Fuel Specifications	10
Fuel Requirements	10
Fuel Consumption	10
Automatic Transfer Switch	11
Battery Installation	12
Battery Safety Instructions	12
Lubrication and Cooling	13
Initial Start up of unit	13
Generator Control Panel Features	14
Generator Control Panel Operation	15
Generator Control Panel - Alarms	16
Overcrank Alarm	16
Overspeed Alarm	16
High Coolant Temperature Alarm	16
Low Oil Pressure Alarm	16
Engine Sender Fault Alarm	16
Low Coolant Level Alarm	16
Generator Control Panel - Pre-Alarms	16
High Coolant Temperature Pre-Alarm	16
Low Coolant Temperature Pre-Alarm	16
Weak Battery Pre-Alarm	16
Battery Over Voltage Pre-Alarm	16
Engine Overload Pre-Alarm	16
Maintenance Pre-Alarm	16
25KW Wiring Diagram (CP500)	17
25KW Wiring Diagram (CP1000)	18
Engine Maintenance	19
Generator Maintenance	19
Troubleshooting	20
Limited Warranty	21
Maintenance Log	22
Parts Drawings / Lists	23-32
Service Information	76

GENERAL SAFETY GUIDELINES

The following information relates to protecting YOUR SAFETY and PREVENTING EQUIPMENT PROBLEMS. To help you recognize this information, we use the following symbols. Please read the manual and pay attention to these sections. Also read and follow all safety labels on the engine/generator set. If labels are damaged or unreadable, contact product service for replacements.



This is the safety alert symbol. It is used to alert you to potential personal injury hazards. Obey all safety messages that follow this symbol to avoid possible injury or death.



Ground Location.

⚠ DANGER: – A POTENTIAL HAZARD THAT WILL CAUSE SERIOUS INJURY OR LOSS OF LIFE.

⚠ WARNING: – A POTENTIAL HAZARD THAT COULD CAUSE SERIOUS INJURY OR LOSS OF LIFE.

⚠ CAUTION: – A POTENTIAL HAZARD THAT MAY CAUSE MODERATE INJURY OR DAMAGE TO EQUIPMENT.

NOTE: Improper installation can damage your electrical system and cause property damage, serious personal injury or death. Installation **MUST** be performed by a licensed electrician and plumber, or gas technician. Installation **MUST** comply with all applicable building and electrical codes. Some areas may require building permits and/or detailed sight inspections prior to approving the unit for operation.

NOTE: The important safety instructions appearing in this manual are not meant to cover all possible conditions and situations that may occur. It must be understood that common sense, caution, and care are factors which are not built into a generator, but are supplied by the person(s) installing, maintaining, and operating it.

⚠ WARNING:

⚠ Do not attempt to install the generator yourself. Extremely high and dangerous electrical voltages are present in utility power source lines and in generator load leads when the unit is running. Therefore, be sure to turn OFF all power voltage supplies at their source before attempting to complete electrical connections. Only qualified installation contractors or electrician's who are familiar with applicable codes, standards, regulations and procedures should install the system. Improper or unauthorized installation, operation, or service of this equipment is extremely hazardous and may result in serious personal injury or death.

⚠ It is NOT intended that the information in this manual be used by any unqualified persons for the purpose of installing a standby electric power system. This equipment must be installed, inspected, tested and adjusted only by qualified personnel. These people must be familiar with the equipment and installation requirements.

⚠ The installation of this unit must comply with the regulations of the United States National Electric Code (NEC) as well as state and local codes and Occupational Safety and Health Administration (OSHA) established in the United States.

⚠ This equipment, when installed as part of a standby electric power system, must be installed in conjunction with an approved transfer switch. The transfer switch serves to prevent both generator and utility power from being connected to the load

circuits at the same time. A properly connected transfer switch helps to prevent backfeed of generator power into commercial lines while the standby generator is operating.





⚠ This generator supplies extremely high and dangerous power voltages. Any contact with high voltage electrically "hot" components will result in extremely hazardous, and possibly LETHAL, electrical shock. Use care to avoid contact with live terminals, bare connectors, bare wires, etc. Disconnect all power before performing maintenance or service.

⚠ Generator exhaust air contains carbon monoxide, a deadly odorless, colorless and tasteless gas. Breathing carbon monoxide causes severe nausea, fainting or death. Install the generator set outdoors only. Do not use exhaust air to heat a room. Do not allow exhaust air to enter a building through windows, doors, air intakes or other means. Avoid breathing exhaust air while installing, operating or servicing generator set. The engine exhaust from this product contains chemicals known to the State of California to cause cancer, birth defects, or other reproductive harm.





⚠ Short circuits can cause bodily injury and/or equipment damage. Do not contact electrical connections with tools or jewelry, make sure clothing and shoes are dry and stand on a dry wooden platform while adjustments are made. Remove wristwatch, rings, and jewelry that can cause short circuits.

GENERAL SAFETY GUIDELINES (Continued)

WARNING:

-  The National Electrical Code (NEC) requires the frame and external electrically conductive parts of the generator to be connected to an approved earth ground.
-  Keep a fire extinguisher near the generator at all times. Extinguishers rated "ABC" by the National Fire Protection Association are appropriate for use on the standby electric system. Keep the extinguisher properly charged and be familiar with its use. If you have any question pertaining to fire extinguishers, consult your local fire department.
-  Generator/engine noise can cause hearing loss. Never operate the generator set without a muffler or with a faulty exhaust system. Always wear hearing protection when near or operating the generator.
-  **DO NOT** permit anyone to operate the standby electric system without proper instruction.
-  In case of accidents caused by electric shock, immediately shut down the source of electrical power. If this is not possible, attempt to free the victim from the live conductor. **AVOID DIRECT CONTACT WITH THE VICTIM.** Use a nonconducting implement, such as a rope or board, to free the victim from the live conductor. If the victim is unconscious, apply first aid and get immediate medical help.

CAUTION:

-  Units with broken or missing parts, without protective housing or covers should never be operated. Contact your service center for replacement parts.
-  Inspect the generator regularly, and contact your nearest Authorized Dealer for parts needing repair or replacement.
-  Never use the generator or any of its parts as a step. Stepping on the unit can stress and break parts, and may result in dangerous operating conditions from leaking exhaust gases, fuel leakage, oil leakage, etc.
-  Thoroughly read the **OPERATORS MANUAL** before operating the generator. Safe operation and top performance can be obtained only when equipment is operated and maintained properly.
-  Ensure that enclosure doors are closed and locked at all times other than during service.

INTRODUCTION

The stationary standby electric generator is manufactured for our customers to supply reliable backup power. The generator is a compact unit, designed to supply the power for your critical needs when utility power fails.



RISK OF ELECTROCUTION AND/OR INJURY



- **The installation of this equipment must be done by licensed electricians contractors gas technicians and plumbers. Installation must be completed in conformance with NEC and local electrical and building codes. Some areas may require building permits and/or detailed sight inspections prior to approving the unit for operation.**

The standby generator will run on Liquid Propane Gas or Natural Gas allowing flexibility for getting the power you need. Fuel lines should be installed by a licensed plumber or other qualified professionals or licensed gas technician.

•About the Owners Manual

Understanding the operation of the generator is important when using or maintaining your system. If there are any questions about the information supplied in this Owner's Manuals, call our customer service helpline number shown on the manual cover.

•About Operation or Maintenance

All required safety checks that need to be performed are the responsibility of the operators. Listed within the Owners Manual are safety precautions that need to be followed to prevent personal injuries to persons around the unit and to prevent property damage.

UNPACKING INSTRUCTIONS

Be sure to inspect the generator carefully for freight loss or damage. If loss or damage is noted at the time of delivery, require that the person making the delivery make note of the loss or damage on the freight bill, or affix his signature under the consignor's memo of the loss or damage. Contact the carrier for claim procedures.

When loss or damage is noted after delivery, segregate the damaged material, and contact the carrier for claim procedures. Be sure to retain the packaging material for carrier inspection.

"Concealed Damage" is understood to mean damage to the contents of a package which is not evident at the time of delivery by the carrier, but which is discovered later. The carrier or carriers are responsible for merchandise lost or damaged in transit. The title to goods rests with the consignee when generators are shipped F.O.B. factory, and only the consignee can legally file a claim.

After inspecting the generator, engine and enclosure for physical damage, finish reading the Operating and Maintenance Instructions. These manuals contain important safety information.



RISK OF INJURY AND BEING CRUSHED



- **HEAVY EQUIPMENT. Unbalanced weight. Improper lifting can cause severe injury or death and equipment damage. The generator frame has been designed with rectangular slots and frame tubes to be used with a forklift for removing the unit from the pallet and positioning the unit on the cement pad.**

GENERATOR SPECIFICATIONS

Rated Wattage - (Standby) 25,000 Watts@1.0PF LPG
22,000 Watts @ 1.0 PF NG

Voltage - 120/240 volts
Rated Current - 208/104 amps LPG
Frequency - 60 HZ
Power Factor - 1.0
Max. Ambient Temp Rise - 105°C
Insulation class - H

Note: Rated wattage is specified at sea level, 60°F ambient temperature, and propane fuel (with 2500 BTU/cuft). Rated wattage decreases approximately 3.5% for each 1000ft above sea level and approximately 1% for each 10°F above 60°F ambient temperature.

ENGINE SPECIFICATIONS

Ford 2.5 - Liter
Type - Water cooled inline (4 cylinders)
RPM - 1800
Displacement - 2500cc(153in³)
Bore X Stroke: 3.78in X 3.40in.
Compression Ratio:9.37:1
Valve arrangement - Overhead valve
Governor - Electronic, Isochronous
Ignition system - Solid state
Starter - 12vdc, Solenoid Shift
Alternator - 12vdc, 90A
Oil capacity - 4.0 qt (3.79L) without filter, 4.50 qt (4.26L) with filter change.
Oil filter - Motorcraft FL400
Radiator capacity - 2.5 gallons, (9.46L). Shipped with 50/50 mix of water and propylene glycol antifreeze.
Spark plug - Motorcraft AWSF 52C.
Battery - BCI Group, minimum 550 CCA.
Air filter - Contact factory

FUEL SPECIFICATIONS

Minimum Content Requirements:
1000 Btus per cubic foot for Natural Gas (NG)
2520 Btus per cubic foot for Liquid Propane vapor (LPG)
Fuel supply pressures must be between 4oz (7" w.c.) and 6oz (11" w.c.) at inlet to the unit.

Consumption at Full Load:
345 cubic feet per hour of Natural Gas (NG)
3.77 gallons per hour of Liquid Propane vapor (LPG)
(1 gallon is equal to 4.26 pounds (LPG))

DIMENSIONS

79"L x 34"W x 43"H (See next page for installation drawing).
Shipping Weight: 1525 lbs.

INSTALLATION DRAWINGS

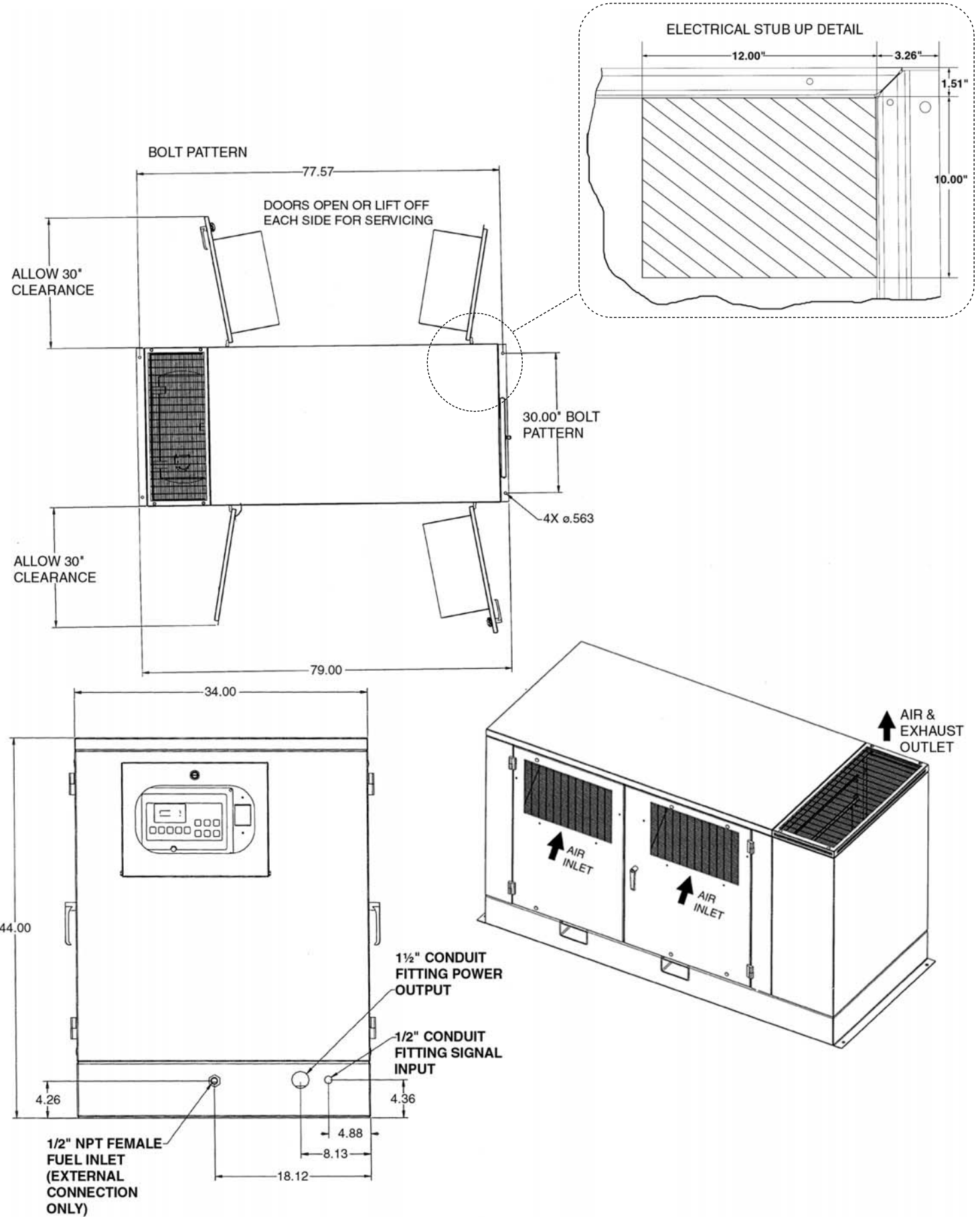

INSTALLATION

DANGER



- **Improper installation can damage your electrical system and cause property damage, serious personal injury or death. Installation MUST be performed by a licensed electrician and plumber, or gas technician and installation MUST comply with all applicable building and electrical codes. Some areas may require building permits and/or detailed sight inspections prior to approving the unit for operation.**

NOTE: The generator frame has been designed with rectangular slots and frame tubes to be used with a forklift for removing the unit from the pallet and positioning the unit on the cement pad.

WARNING



- **Hazardous voltage can cause severe injury or death. Electrocution is possible whenever electricity is present. Open the main circuit breaker of all power sources before servicing the equipment. Configure the installation to electrically ground the generator set, transfer switch and related equipment and electrical circuits to comply with applicable codes and standards. Never contact electrical leads or appliances when standing in water or on wet ground because these conditions increase the risk of electrocution.**
- **When lifting the generator or using hoisting equipment, be careful not to touch overhead power lines. Proper tools and equipment and qualified personnel should be used in all phases of handling and unpacking.**
- **This generator has an open bottom and must be mounted on a cement pad.**
- **The exhaust from this product is extremely hot and remains hot after shutdown. High grass, weeds, brush, leaves, or other combustible materials, must remain clear of the exhaust. Such materials may ignite and burn from the heat of the exhaust system.**

LOCATION AND GENERATOR PLACEMENT

NOTE: The generator has an engine fan that draws the air in from the side panel slots, circulates it within the enclosure and forces the air through the radiator and out the lid on the exhaust outlet side of the unit.

For proper ventilation and maintenance, locate the generator outdoors in an area that will allow a minimum

of four feet of clearance between the generator and any other structure.

When placing the generator, the direction of the exhaust should be pointing away from windows, doors and any ventilation system.

Insure that sufficient air flow is available to remove the exhaust fumes and cool the generator properly.

CAUTION

- **Covering or restricting the air passages on the generator will cause the unit to overheat and may create a fire hazard. Do not allow snow or leaves to cover enclosure openings.**
- **Leave a four foot open area around all sides of the unit. Do not plant trees or plants which may grow within four feet of the unit.**
- **Unit should be located such that it prevents combustible material from accumulating under the generator set.**
- **The generator MUST be installed outdoors.**

The generator should be installed with masonry anchor bolts on a level wire reinforced cement pad that is 4-6 inches thick and extends a minimum of 6" around all sided of the unit.

NOTE: It would be extremely difficult, if not impractical, to attempt a detailed coverage of every installation possibility. For that reason, much of the information is general in nature. Plan the installation carefully. Information in this manual is provided as a guide only and is not meant to serve as a detailed installation plan. Illustrations provided in the manual must not be construed as blueprints.

All local applicable codes, standards and regulations must be followed for the installation of the generator. Some areas may require building permits and/or detailed sight inspections prior to approving the unit for use.

NOTE: Utility wiring from the house to power the battery charger and other start assisting components should be tightened on the identified terminal block at a torque of 20 lb-in. The wire size is to be selected according to allowable ampacities given in Table 310-16 of the National Electric Code.

Signal wiring from the transfer switch is to be 18AWG multi-strand wire tightened on the identified terminal block to a torque of 20 lb-in.

Power leads from the generator/circuit breaker being wired to the transfer switch should be tightened in the identified terminal block to 120 lb-in. The wire size is to be selected according to allowable ampacities given in Table 310-16 of the National Electric Code.

Field wiring of this unit must be conducted by a licensed electrician.

LOCATION AND GENERATOR PLACEMENT (continued)

⚠ DANGER ⚠



- The generator engine exhaust fumes contain carbon monoxide, which can be DEADLY. This dangerous gas, if breathed in sufficient concentrations, can cause unconsciousness or even death. The generator must be installed properly, in strict compliance with applicable codes and standards. Following installation, you must do nothing that might render the generator unsafe or in noncompliance with such codes and standards.
- Considerations for proper rooftop placement and weight distribution must be designed by a qualified engineer or architect.

⚠ WARNING ⚠



- For fire safety, the generator must be installed and maintained properly. Installation always must comply with applicable codes, standards, laws and regulations. Adhere strictly to local, state and national electrical and building codes. Comply with regulations the Occupational Safety and Health Administration (OSHA) and National Electrical Code (NEC) have established.
- This generator is designed to be installed outside only. Never install this unit inside any room, enclosure, or basement. The generator needs adequate cooling and ventilation for continued proper and safe operation.

WIRING INSTALLATION DETAIL

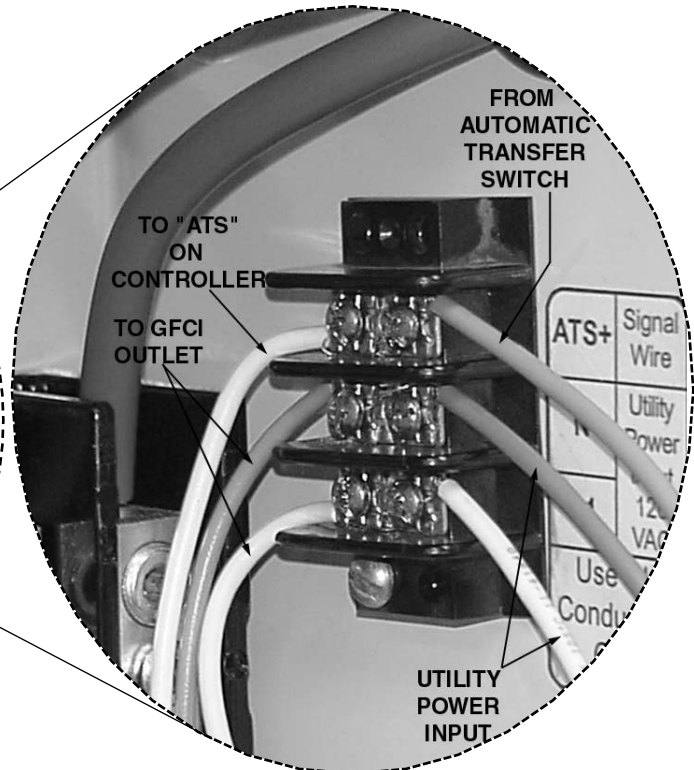
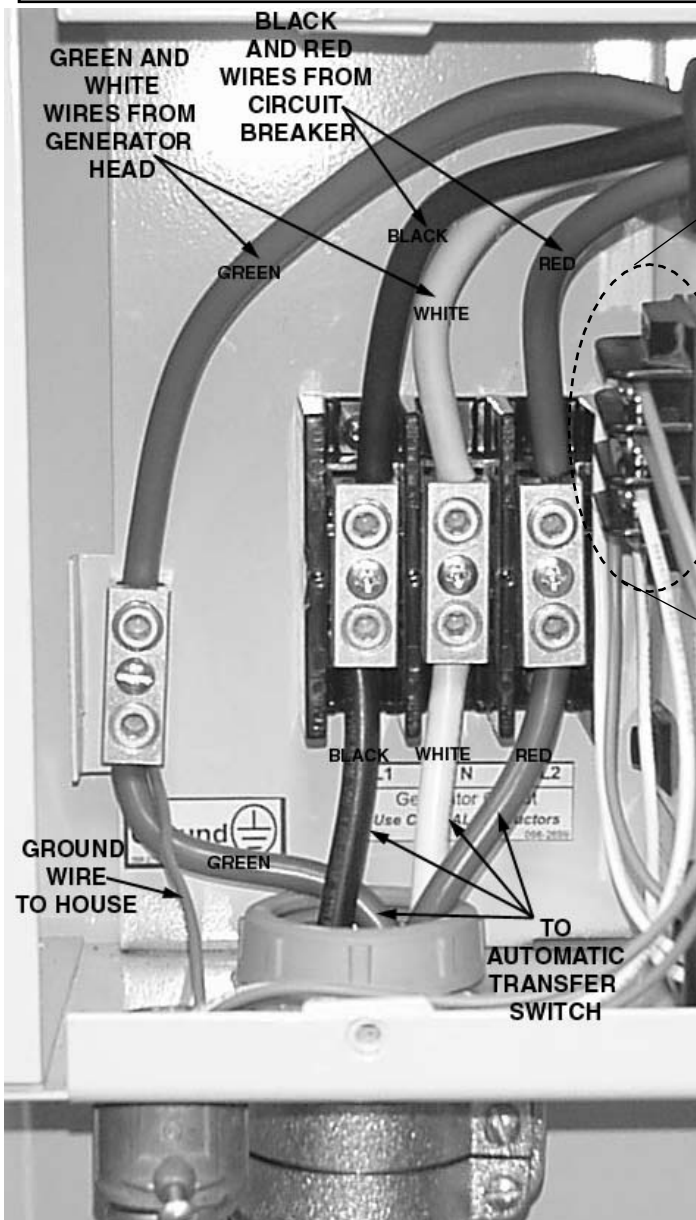

⚠ WARNING ⚠



- In case of accidents caused by electric shock, immediately shut down the source of electrical power. If this is not possible, attempt to free the victim from the live conductor. AVOID DIRECT CONTACT WITH THE VICTIM. Use a nonconducting implement, such as a rope or board, to free the victim from the live conductor. If the victim is unconscious, apply first aid and get immediate medical help.

FUEL SELECTION

NATURAL GAS (NG) SETTINGS

Units are tested with natural gas before they leave the factory. If natural gas is to be used, no adjustments are required. The fuel select switch, located on the bottom of the control panel, should be in the (NG) position. The (NG) position is with the switch depressed away from the front of the control panel (see **A** in illustration 1)

LIQUID PROPANE VAPOR (LPG) SETTINGS

The fuel select switch position for liquid propane vapor (LPG) is with the switch depressed toward the front of the control panel (see **B** in illustration 1).

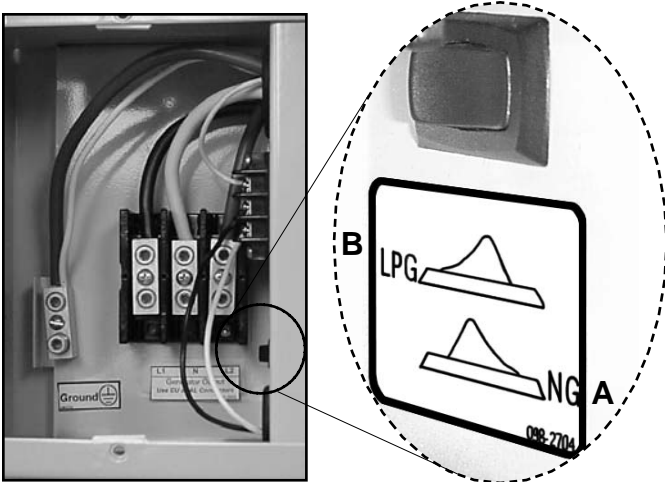

Illustration 1

WARNING



- Natural gas (NG) is highly explosive.
- Natural gas (NG) is lighter than air and will collect in high places.
- Liquid propane vapor (LPG) is highly explosive.
- Liquid propane vapor (LPG) is heavier than air and will collect in lower places.
- Extreme caution should be taken when working on a new installation or while performing general maintenance.
- Do not smoke when near the unit.
- Keep flames, sparks, pilot lights, arc-producing equipment, switches and all other sources of ignition well away. Keep a type ABC fire extinguisher handy.
- Potential for fire or explosion always exist when using natural gas (NG) or liquid propane vapor (LPG) as a fuel source. Install this unit in compliance with all local fuel codes.
- Do Not operate engine if smell of fuel is present or other explosive conditions exist.

Per the National Gas Code (NFPA 54 - ANSI 2223.1), a manual shutoff valve in the fuel supply line to the generator is recommended. All fuel system installations **MUST BE** done by a licensed plumber or licensed gas technician and must comply with all applicable codes, standards and regulations.

CARBURETOR ADJUSTMENTS

The main adjustment screw is located on the side of the fuel mixer (as shown in illustration 2). Start unit at no load and verify proper operation. Loosen jam nut on adjusting screw. Slowly load unit to full load, adjusting load screw counter-clockwise as required to achieve maximum power. Once smooth full load operation is achieved, tighten adjustment screw jam nut, then return unit to no load to verify proper operation.

CAUTION

- This adjustment should only be performed by trained personnel. If incorrect adjustments are made, the unit may fail to operate or operate inefficiently.

Illustration 2

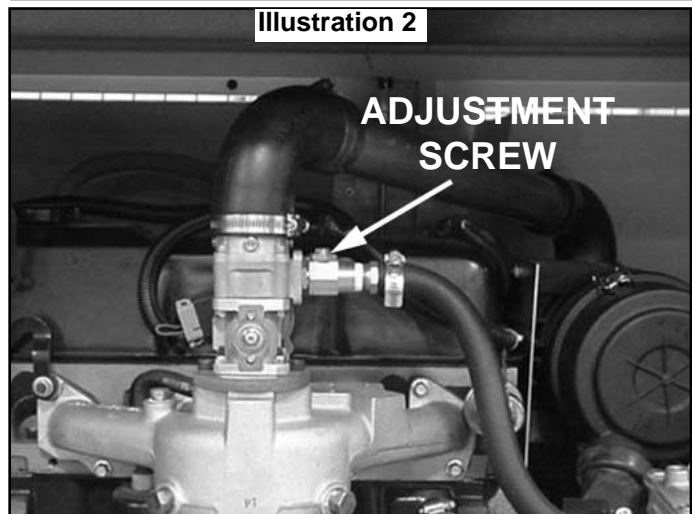

FUEL SPECIFICATIONS

FUEL REQUIREMENTS:

For the best operation of the unit, the fuels used should have a minimum content of 1000 BTU's per cubic foot for Natural Gas (NG) and 2520 BTU's per Cubic foot for Liquid Propane vapor (LPG). Contact local fuel supplier for local BTU content. Fuel supply pressures must be between 4oz (7" H₂O per square inch) and 6oz (11" H₂O per square inch) at the inlet to the unit.

FUEL CONSUMPTION:

The PowerStation 25Kw at full load consumes 306,000 BTU's per hour of natural gas (NG) and 354,000 BTU's per hour of liquid propane vapor (LPG).

AUTOMATIC TRANSFER SWITCH

This generator must be connected to an automatic transfer switch. The automatic transfer switch detects when a power failure occurs and automatically starts the engine to provide generator power. When the utility power becomes available, the transfer switch automatically shuts down the generator and switches back to the utility power. (See figure 1 for typical installation).

Refer to the transfer switch manual for detailed installation and safety instructions. Comply with all the instructions in the manual along with the labels and tags attached to the transfer switch.

⚠ WARNING ⚠



- Hazardous "backfeed" voltage can cause severe injury or death. Install a transfer switch in standby power installations to prevent connection of standby and other sources of power. Electrical backfeed into a utility electrical system can cause serious injury or death to utility personnel working on transmission lines.
- Do not try MANUAL operation of the transfer switch until all power supplied to the switch has been positively turned OFF. Failure to turn OFF power supplied may result in extremely dangerous and possibly lethal electrical shock or arcing.

Figure 1

Example of typical installation

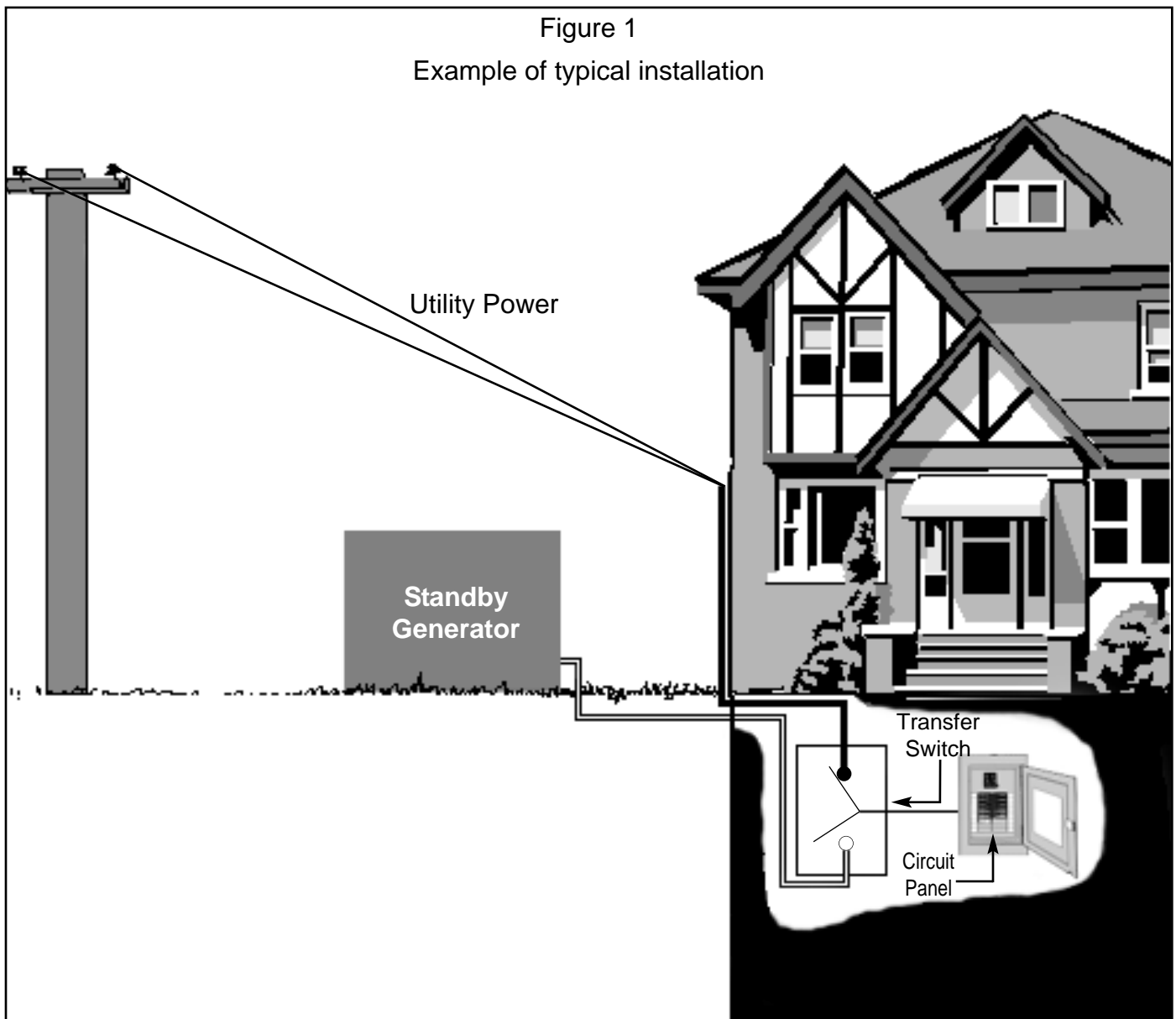

BATTERY INSTALLATION

Minimum recommended battery size is a BCI Group 26 with a minimum of 550 CCA (Cold Cranking Amps). Place the battery in the battery rack as shown and secure using the hold-down hardware provided.



Once the battery has been placed and tied down with the battery hold down bar, connect the leads to the respective battery post. Always connect the (red) positive cable first and the negative (black) cable last. When disconnecting remove negative cable first and then positive lead last.

Note: The battery charger will automatically charge the battery to keep a full charge. This charger is connected to your normal electrical supply to keep your battery charged while the generator is idle.

The charger is not intended to recharge a battery which has become completely discharged.

When replacing batteries, use the same number and the following type batteries: **BCI Group 26 vented battery.**

The nominal voltage rating of the battery supply is 12 volts.

BATTERY SAFETY INSTRUCTIONS

Servicing of batteries are to be performed or supervised by personnel knowledgeable of batteries and the required precautions. Keep unauthorized personnel away from batteries.

WARNING



Lead-acid batteries present a risk of fire because they generate hydrogen gas. The following procedures are to be followed:

- Do not smoke when near batteries.
- Do not cause flame or spark in battery area.
- Discharge static electricity from body before touching batteries by first touching a grounded metal surface.
- Do not dispose of batteries in a fire. The battery is capable of exploding.
- Do not open or mutilate the battery or batteries. Released electrolyte has been known to be harmful to the skin and eyes and to be toxic.

WARNING



The electrolyte is a dilute sulfuric acid that is harmful to the skin and eyes. It is electrically conductive and corrosive. The following procedures are to be observed.

- Wear full eye protection and protective clothing.
- Where electrolyte contacts the skin, wash it off immediately with water.
- Where electrolyte contacts the eyes, flush thoroughly and immediately with water and seek medical attention.
- Spilled electrolyte is to be washed down with and acid neutralizing agent. A common practice is to use a solution of one pound (500 grams) bicarbonate of soda to one gallon (4 liters) of water. The bicarbonate of soda solution is to be added until the evidence of reaction (foaming) has ceased. The resulting liquid is to be flushed with water and the area dried.

CAUTION



A battery presents a risk of electrical shock and a high short circuit current. The following precautions are to be observed when working on batteries:

- Remove watches, rings or other metal objects.
- Use tools with insulated handles.
- Wear rubber gloves.
- Do not lay tools or metal parts on top of batteries.
- Disconnect charging source prior to connecting or disconnecting battery terminals.
- Determine if the battery is inadvertently grounded. When inadvertently grounded, remove source of ground. Contact with any part of a grounded battery is capable of resulting in electrical shock. The risk of such shock is reduced when such grounds are removed during installation and maintenance.
- Failure to connect and disconnect in the proper sequence can cause equipment damage. Ensure there is a clean tight fit from the cables to the post.

LUBRICATION AND COOLING

Check oil level before start-up. The unit is shipped with the proper type of oil in the crankcase for operation above 40°F. Follow the engine manufacturer's recommendations for oil at temperatures below 40°F. Check oil periodically to ensure that the unit is properly lubricated. Follow the engine manufacturer's recommended service schedule.

Engine oil capacity is 4.0 qt (3.79L) without a filter change and 4.50qt (4.26L) with a filter change.

Before initial start up of the unit, check the coolant level in the radiator. Low coolant levels can cause insufficient engine cooling and possible engine damage. The unit is shipped with a 50\50 mix of water and propylene glycol antifreeze in the radiator. Check coolant levels and concentration periodically, especially in extreme climates. Follow engine manufacturer's recommended service schedule. If radiator is drained and refilled, make sure to disconnect bypass hose to purge air from radiator and engine head water passages.

Failure to properly bleed air from the cooling system may result in an engine failure not covered under warranty.

WARNING



- Hot coolant under pressure in radiator can cause severe burns. Allow radiator to cool completely before removing cap.
- Eye protection should be used.

CAUTION

- Too much oil can cause high oil consumption, high operating temperatures and oil foaming. Too little oil can cause severe engine damage. Keep the oil level between the full and add marks on the dipstick.
- Any attempt to crank or start the engine before it has been properly serviced with the recommended oil will result in an engine failure that is not covered under warranty.
- Never run this equipment without the complete air cleaner system installed on the engine. Failure to do so will result in premature engine wear and significantly reduced engine life.

INITIAL START UP OF UNIT

NOTE: Some areas require that a building inspector and/or electrical inspector to evaluate the installation prior to operation.

CAUTION



- **Prestart checks MUST BE performed by a licensed electrician and plumber or licensed gas technician.**

PRESTART CHECKS:

- Check oil level.
- Check coolant level.
- Check battery connection and charge.
- Check that fuel line connections are tight and leak free. Test connections for leaks with soapy water.
- Check field installed fuel lines and fittings to ensure proper sizing and gas pressure.
- Move main circuit breaker to on position.

INITIAL TEST OF THE SYSTEM:

Once all the prestart up checks have been completed the unit can now be started for the first time.

The initial test of the generator is important because it will indicate any problems that the generator may have due to installation or shipping.

Before starting the generator, read and understand the operation of the controller panel. After becoming familiar with the controller operation, start the generator set by pressing the RUN button.

CAUTION

- Failure to set the controller to AUTO before leaving the generator renders the generator unavailable for automatic standby service.
- **DO NOT attempt to adjust the governor. ONLY QUALIFIED SERVICE TECHNICIANS SHOULD ADJUST THE ENGINE GOVERNOR.** Excessively HIGH operating speeds are dangerous and increase the risk of personal injury. LOW operating speeds impose a heavy load on the engine when adequate engine power is not available and may shorten engine life. Correct rated frequency and AC voltage are supplied only at the proper governed speed. Some connected electrical load devices may be damaged by incorrect AC frequency and/or voltage.

GENERATOR CONTROL PANEL FEATURES

- A** Two line by twenty character LCD provides the primary visual interface for metering, alarms, pre-alarms and protective functions. In the normal mode, labels appear above and below the display. In the alternate display mode, labels and the displayed value appear on the display.
- B** Red LED turns ON when the device is not in the AUTO mode.
- C** Red LED turns ON continuously for all alarm conditions and flashes for pre-alarm conditions.
- D** Green LED turns ON when the generator is supplying more than two percent of generator full load rated current.
- E** Pushbutton used to silence an optional audible alarm.
- F** Pushbutton used to exercise all segments of the LCD and to illuminate all LED's.
- G** Pushbutton used to place the device in AUTO mode.

⚠ WARNING ⚠



- **With the Mode switch in the Auto position, the unit starts and stops without notice.**
- **Keep clear of all moving parts at all times.**

- H** Green LED turns ON when the device is in the AUTO mode.

⚠ WARNING ⚠



- **Place the circuit breaker in the OFF position when servicing the generator to minimize electrocution hazards.**
- I** Pushbutton used to place the unit in the OFF mode.
- J** Red LED turns ON when the device is in the OFF mode.
- K** Pushbutton used to place the device in the RUN mode.
- L** Green LED turns ON when the device is in the RUN mode.
- M** Pushbutton used to scroll through the displays available in the normal display mode.
- N** Pushbutton used to scroll through the display modes.
- O** Pushbutton used to scroll through previous menu levels.
- P** Pushbutton used to enter menu sublevels and select set points.
- Q** Pushbutton used to scroll backward through the menus and to decrement set points.
- R** Pushbutton used to scroll forward through the menus and to increment set points.

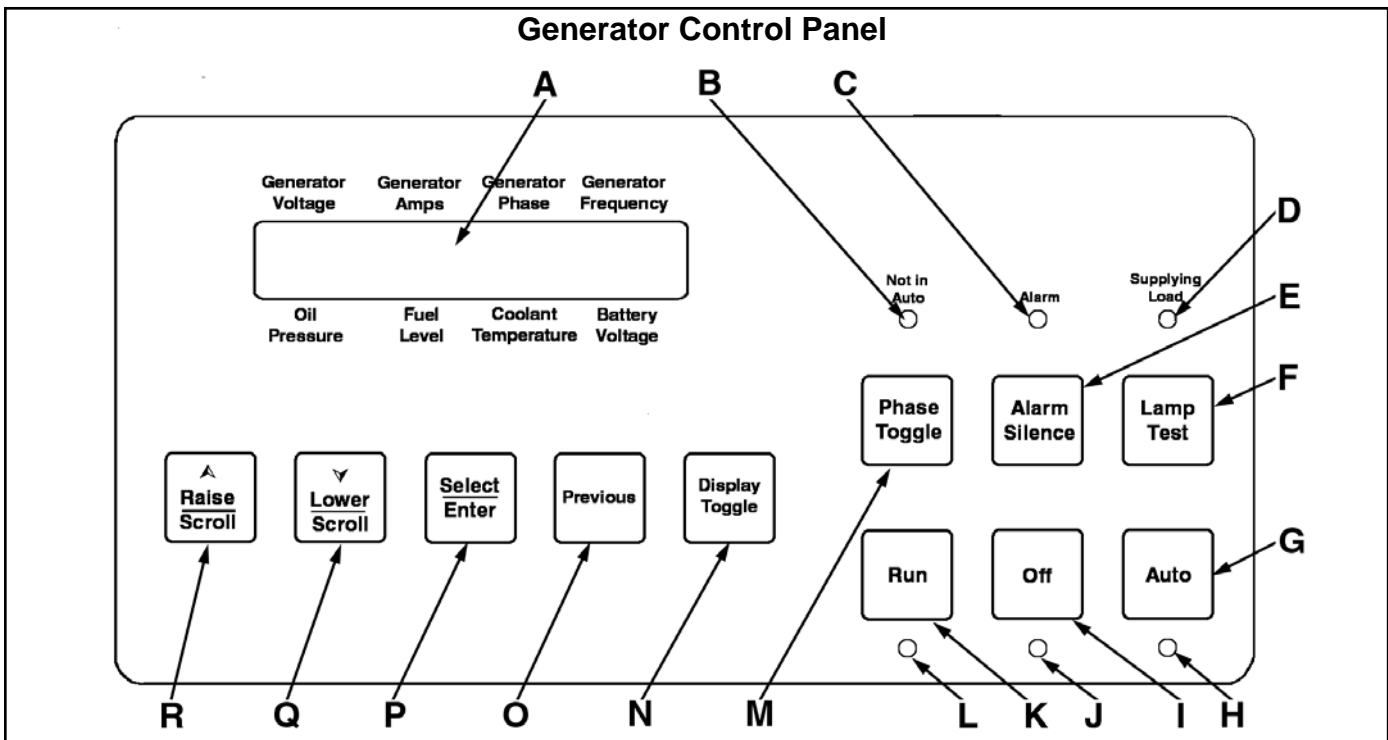

GENERATOR CONTROL PANEL OPERATION

DISPLAY MODE

Pressing the **Display/Toggle** pushbutton allows the user to scroll through the Normal, Alternate and Menu display Modes.

ALTERNATE DISPLAY MODE

Alternate Display Mode can be used to observe generator performance including oil pressure, coolant temperature, battery voltage, kilowatt load, generator voltage, kVA, hours to next service, amps, generator frequency, total run hours, engine speed, and unit identification number.

After pressing the **Display/Toggle** pushbutton to enter the alternate display mode, pressing the **Raise/Scroll** or **Lower/Scroll** pushbutton allows the user to scroll through the alternate display mode screens.

MENU MODE

Menu Mode can be used to observe settings programmed into the control panel. The menus include information on alarms, system configuration, sensing devices, and engine parameters.

To access the Menu Mode press the **Display/Toggle** (if in Normal Mode) pushbutton twice to begin the Menu display. Options can be selected by pressing the **Raise/Scroll** or **Lower/Scroll** pushbuttons, and after locating the desired option, pressing **Select/Enter** begins the next level of menus.

RUN MODES

There are three run mode options: **Run**, **Off** and **Auto**. When the **Run** pushbutton is pressed the unit will immediately start and the “not in auto” light will illuminate. In **Run** mode, the generator will continue to run until the **Off** pushbutton is pressed to stop the unit. At this point the “not in auto” light will illuminate and the unit will not operate.

When the **Auto** pushbutton is pressed the unit will enter automatic run mode, where the generator controller and the transfer switch will control the operation of the unit. In automatic run mode, the unit will automatically start up and shut off when power failure occurs and to exercise the unit.

When power failure occurs, a signal will be sent to the generator to start a warm up cycle. After the warm up cycle is completed, the transfer switch will allow the load to be transferred to the generator until it senses that regular utility power has been restored. When this occurs, the transfer switch will remove the load from the generator and a signal will be sent to the generator to begin a cool down cycle. After the cool down cycle is completed, the unit will stop running, but remain in the automatic run mode.

The unit will also automatically start itself to ensure it remains in good working order. Every 14 days the unit will automatically start up without warning and run for 20 minutes before shutting down. The unit will remain in automatic run mode after each exercise session.

⚠ WARNING ⚠



- **The unit will automatically start and stop without notice.**

GENERATOR CONTROL PANEL FEATURES - ALARMS

When the generator control panel senses an abnormal operating condition, an alarm is declared and the generator set is shutdown. All alarm conditions will light a red LED (labeled **Alarm**) along with displaying the condition on the LCD screen. When an alarm condition occurs, the display indicates the cause of the alarm and the fuel solenoid contact opens which shuts down the engine. Resetting alarms can only be done locally by setting the Auto/Off/Run switch to the OFF position.

OVERCRANK ALARM

During unit start-up the controller performs a cyclic cranking procedure. At that time, the common alarm contacts close and the LCD displays the message OVERCRANK and the current overcrank setting.

OVERSPEED ALARM

If the generator speed exceeds a pre-programmed speed, an overspeed alarm is displayed. At that time, the common alarm contact closes and the LCD displays the message OVERSPEED and the current overspeed setting.

HIGH COOLANT TEMPERATURE ALARM

If the engine coolant temperature exceeds a factory set level an alarm occurs. At that time, the common alarm contact closes and the LCD displays the message HIGH COOLANT TEMP and the current high coolant temperature setting.

 **WARNING** 

- **Hot coolant under pressure in radiator can cause severe burns. Allow radiator to cool completely before removing cap.**
- **Eye protection should be used.**

LOW OIL PRESSURE ALARM

If the oil pressure decreases below the low oil pressure alarm setting programmed, an alarm occurs. At that time, the common alarm contact closes and the LCD displays the message LOW OIL PRESSURE and the current low oil pressure alarm setting.

ENGINE SENDER FAULT ALARM

If an engine sender (transducer) fails, an alarm is displayed. At that time, the common alarm contact closes and the LCD displays the message **SENDER FAILURE** and the failed sender type.

LOW COOLANT LEVEL ALARM

This alarm will shut down the engine when a loss of coolant is detected via an optional low coolant level sensor. At that time, the common alarm contact closed and the LCD displays the message LOW COOLANT LEVEL.

GENERATOR CONTROL PANEL FEATURES - PRE-ALARMS

All pre-alarm conditions illuminate the red alarm LED with a 50% duty cycle at a frequency of 0.5 hertz and sounding the optional audible alarm at the same rate. The LCD displays all pre-alarms in the following manner: Low Oil Pressure, High Coolant Temperature, and Battery Voltage pre-alarms are shown on the main display with their current values alternately flashing. All other pre-alarms are individually displayed in sequence, using the alternate main display mode, whereby each pre-alarm value is alternately flashed. All pre-alarmed parameters are displayed in this manner before non-pre-alarmed parameters. All pre-alarms are reset by correcting the cause of the pre-alarm. Audible pre-alarms can be reset by the Alarm Silence pushbutton.

HIGH COOLANT TEMPERATURE PRE-ALARM

If engine coolant temperature increases above the high coolant temperature pre-alarm setpoint, a pre-alarm occurs.

LOW COOLANT TEMPERATURE PRE-ALARM

If engine coolant temperature decreases below the low coolant temperature pre-alarm setpoint, a pre-alarm occurs.

WEAK BATTERY PRE-ALARM

If the battery voltage drops below 60% of the nominal voltage for more than 2 seconds during engine cranking, a pre-alarm occurs. The message **Weak Battery** is displayed in the alternate display mode and is reset by scrolling through the alternate display.

LOW BATTERY VOLTAGE PRE-ALARM

If the battery voltage decreases below the low battery voltage value programmed, a pre-alarm occurs.

BATTERY OVER VOLTAGE PRE-ALARM

If the battery voltage exceeds the battery over voltage value programmed, a pre-alarm occurs.

ENGINE OVERLOAD PRE-ALARM

If the engine load exceeds the engine overload level pre-alarm value programmed, a pre-alarm occurs.

MAINTENANCE PRE-ALARM

When the next scheduled maintenance timer reaches zero hours, a pre-alarm occurs. After the required maintenance is performed, the pre-alarm can be cleared from the front panel. To clear the pre-alarm from the front panel, go to the alternate display mode and scroll to the screen that displays HRS TO NEXT SERVICE. Pressing the Select/Enter button while on this screen will clear the maintenance pre-alarm and reset the maintenance timer back to its programmed starting value.

25KW WIRING DIAGRAM (CP500 CONTROLLER)
SCHÉMA DE CÂBLAGE 25KW (CONTRÔLEUR CP 500)
DIAGRAMA DE CIRCUITO ELÉCTRICO DE 25 KILOVATIOS (CONTROLADOR CP500)

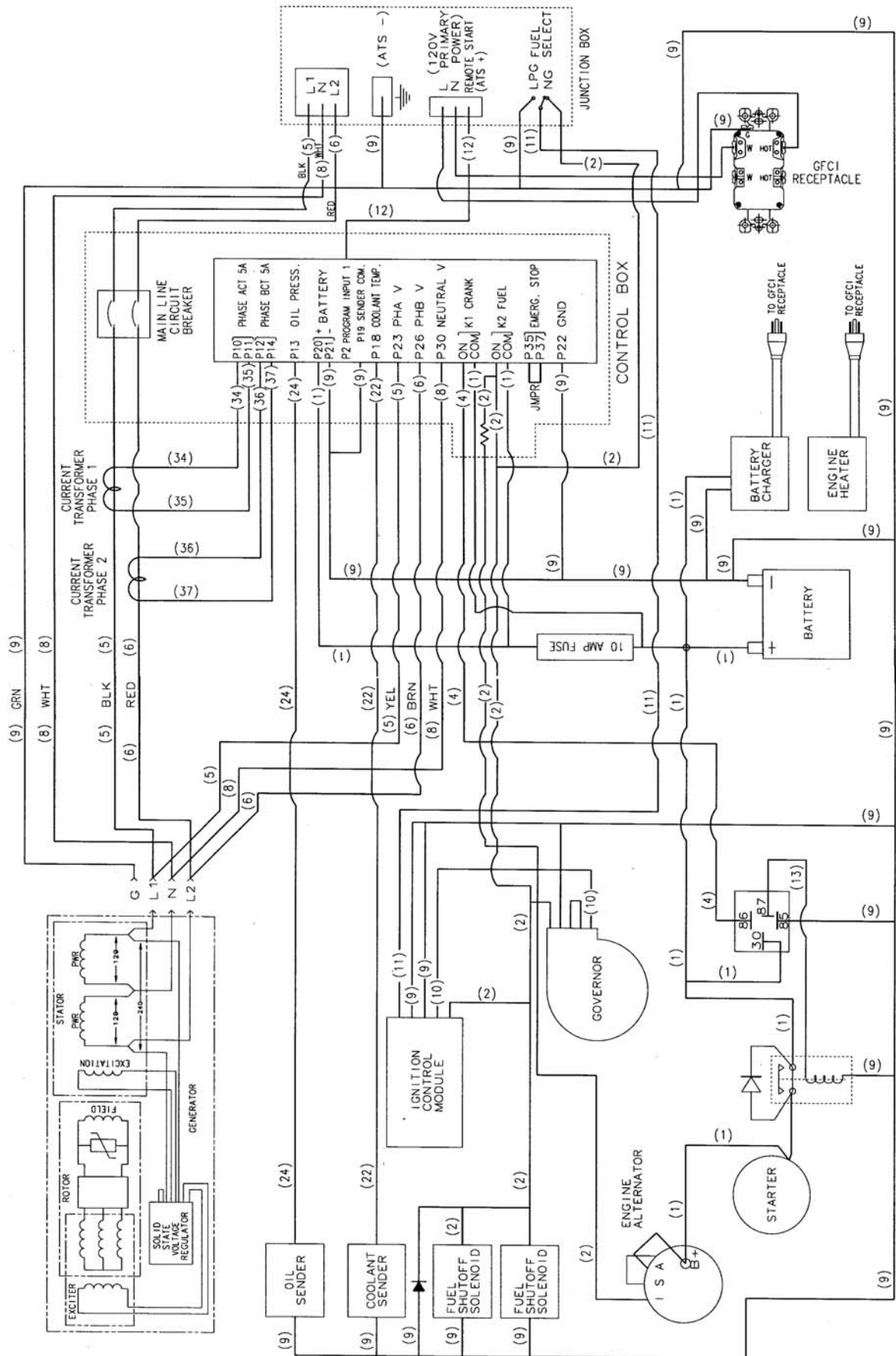

25KW WIRING DIAGRAM (CP1000 CONTROLLER)

SCHÉMA DE CÂBLAGE 25KW (CONTRÔLEUR CP 1000)

DIAGRAMA DE CIRCUITO ELÉCTRICO DE 25 KILOVATIOS (CONTROLADOR CP1000)

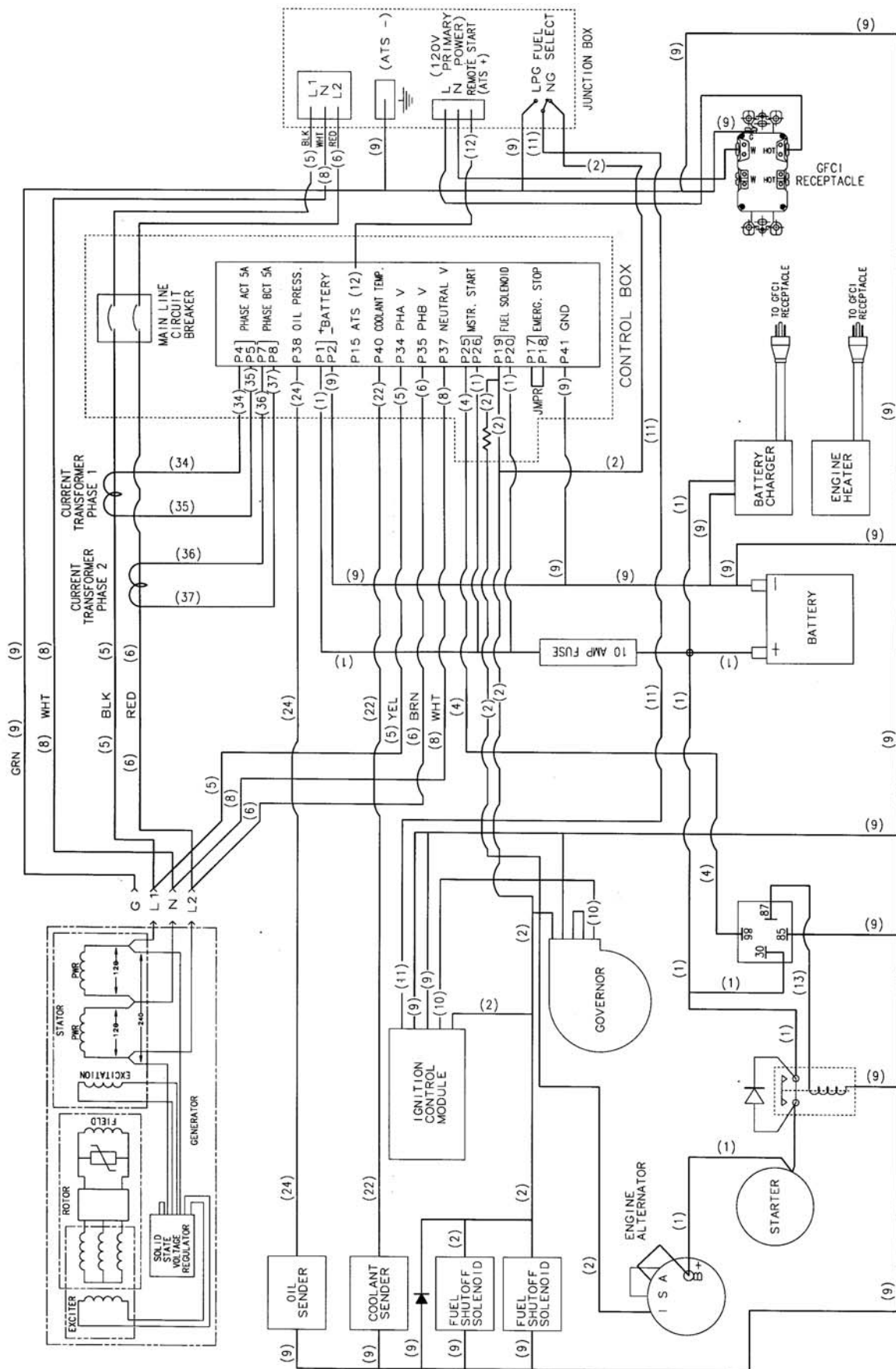

ENGINE MAINTENANCE

- Check oil every 8 hours of operation.
- Change oil and oil filter every 100 hours of operation.
- Change air filter every 400 hours.
- Replace spark plugs every 500 hours .
- Check Coolant level every 8 hours of operation. Check coolant mixture at least twice a year using a hygrometer.

WARNING



- State and federal agencies have determined that contact with used engine oil can cause cancer or reproductive toxicity. Take care to limit skin contact and breathing of vapors as much as possible. Use rubber gloves and wash exposed skin.
- The engine exhaust from this product contains chemicals known to the State of California to cause cancer, birth defects, or other reproductive harm.

GENERATOR MAINTENANCE

- Check battery terminals at least twice a year. Follow any additional instructions and warnings that accompany the battery.
- Check fuel lines for leaks with soapy water at least twice a year. If leaks are detected contact a licensed plumber or licensed gas technician.
- Keep the unit clean of debris and dirt. No maintenance is required on the generator head.

WARNING



- Do not smoke around the generator. Wipe up any fuel or oil spills immediately. Ensure that no combustible materials are left in the generator compartment, or on or near the generator, as FIRE or EXPLOSION may result. Keep the area surrounding the generator clean and free from debris.
- When performing maintenance on this equipment, nothing should be done that might render the equipment or its installation in non-compliance with applicable codes, standards, and regulations.

WARNING



- Before performing any maintenance, make sure the Mode switch is in the OFF position, the circuit breaker is in the OFF position and the positive (red) battery cable is disconnected.
- Generator/engine components are hot to the touch when operating. To prevent burns to the skin allow unit to cool before touching internal generator or engine components.
- Crankcase pressure can blow hot engine oil out the fill opening causing severe burns. Always stop the generator before removing the oil fill cap.
- Keep hands, feet, clothing, etc., away from drive belts, fans, and other moving or hot parts. Never remove any drive belt or fan guard while the unit is operating.
- Hot coolant under pressure in radiator can cause severe burns. Allow radiator to cool completely before removing cap. Eye protection should be used.
- Generator output connections must be made by a qualified electrician in accordance with applicable codes.
- Engine block heater can cause electrical shock. Remove engine block heater plug from electrical outlet before working on block heater connections.
- Improper service or replacement of parts can lead to severe personal injury or death and to damage to equipment and property. Service personnel must be qualified to perform electrical and mechanical service.
- Use caution when working on live electrical equipment. Remove jewelry, make sure clothing and shoes are dry and stand on a dry wooden platform.
- When performing a high voltage test, hazardous voltage can cause severe injury or death. Follow the instructions of the test equipment manufacturer when performing high-voltage tests on the rotor or stator. An improper test procedure can damage equipment or lead to generator set failure.

TROUBLESHOOTING

SYMPTOM	POSSIBLE CAUSE	CORRECTIVE ACTION
Engine will not crank in Manual mode.	1. Defective Battery.	Recharge or replace battery.
	2. Blown control panel fuse.	Replace fuse.
	3. Loose or dirty connections.	Check and clean D.C. connections.
	4. Defective crank relay.	Call customer service.
	5. Defective Starter.	Call customer service.
	6. Defective Control.	Call customer service.
Engine will crank in manual mode but will not start.	1. No fuel.	Check fuel supply and manual operated fuel valves.
	2. Defective controller.	Call customer service.
	3. Defective fuel solenoid.	Call customer service.
	4. Problem with engine ignition system.	Call customer service.
Engine runs but no A.C. output from the generator.	1. Main circuit breaker tripped.	Reset breaker.
	2. Defective generator.	Call customer service.
	3. Improper output connections.	Call customer service.
	4. Defective voltage regulator	Call customer service.
	5. Loss of rotor residual magnetism	Call customer service.
Fault light on, engine will not start.	1. Low oil pressure.	Check oil level.
	2. High coolant temperature.	Allow unit to cool. Check coolant level.
	3. Overcrank error.	Check fuel and ignition systems. Check battery and connections.
Engine starts but shuts down immediately.	1. Low oil pressure.	Check oil level.
	2. Low fuel pressure.	Call customer service.
	3. Defective Controller.	Call customer service.
Battery will not stay charged.	1. Defective battery.	Replace battery.
	2. Defective connections.	Clean and tighten connections.
	3. Defective alternator.	Call customer service.
	4. Defective battery charger.	Call customer service.
Engine will not run at full speed or runs rough.	1. Insufficient fuel volume.	Check fuel line. Replace fuel regulator. Check regulator vent for obstructions.
	2. Engine electrical problem.	Replace spark plugs. Check ignition wiring or call customer service.
	3. Engine configured for wrong fuel.	Check fuel select switch.
	4. Generator over loaded.	Reduce load.

Coleman PowerStation™ Stationary Standby 3-Year or 1500 Hour Limited Warranty

Your Coleman PowerStation™ emergency back up power system generator™ has been manufactured to stringent guidelines & standards for years of dependable operation & service. Coleman Powermate warrants this product to the original consumer against defects in material and workmanship for a period of 3-Years or 1500 hours, whichever occurs first, from the date of purchase and is not transferable.

Coverage:

Replacement parts & labor, including travel time & mileage, for defects in product found to be properly installed, maintained & operated in accordance with Coleman Powermate & supplied component operator's manuals are eligible for warranty coverage. A Coleman Powermate Authorized Master Representative, their dealer or their agent must perform warranty service. Items not covered under the warranty are:

- ⇒ Normal engine wear, tune-ups, and routine service.
- ⇒ Damage caused by shipping, accidents, improper installation or handling, improper storage, or repairs not performed by a Coleman Powermate authorized Master Representative, their dealer or their agent.
- ⇒ Damage caused by operation with improper fuel or at speeds, loads, conditions, modifications, or installation contrary to published specifications or recommendations.
- ⇒ Damage caused by negligent maintenance such as:
 - Failing to provide the specified type and sufficient quantity of lubricating oil.
 - Failing to keep the air intake and cooling areas clean.
 - Failing to service the air cleaner.
 - Failing to provide sufficient coolant.
 - Failing to perform scheduled maintenance as recommended by Coleman Powermate or by supplied component manufacturers.
 - Failing to regularly exercise the generator set.
- ⇒ Original installation charges and startup costs.
- ⇒ Starting batteries, travel & labor associated with battery failure.
- ⇒ Rental of equipment during performance of warranty repairs.
- ⇒ Engines, or other components, which are covered exclusively by the warranty of their manufacturer.
- ⇒ Altered, tampered or improperly maintained emission control system components.
- ⇒ Parts purchased for a replacement of a failed Coleman Powermate part with a non-Coleman Powermate part voids warranty on that part.
- ⇒ Fuel injection pumps not repaired locally by an authorized servicing dealer.
- ⇒ Non-Coleman Powermate-authorized repair shop labor without prior approval from Coleman Powermate Warranty Department.
- ⇒ Engine fluids such as fuel, oil, or coolant/antifreeze.
- ⇒ Expenses incurred investigating performance complaints unless defective Coleman Powermate materials or workmanship is the cause of the problem.
- ⇒ Maintenance items such as fuses lamps, filters, spark plugs and adjustments.
- ⇒ Sales outside the U.S. or Canada
- ⇒ Telephone charges or transportation charges in connection with the repair of defective parts.
- ⇒ Overtime labor charges incurred at the request of owner unless prior approval is obtained by Coleman Powermate.
- ⇒ Air freight charges or shipping charges outside of Coleman Powermate shipping practices
- ⇒ Any other expense including consequential damages, incidental damages, or incidental expenses, including damage to property. Some states do not allow the exclusion or limitation of incidental damages, so the limitation may not apply to you.

Implied Warranties:

Any implied warranties, including the Implied Warranties of Merchantability and Fitness For A Particular Purpose, are limited in duration to 3-Years or 1500 Hours from the date of consumer purchase. Some states do not allow limitations on how long an implied warranty lasts, so the limitation may or may not apply to you.

How To Obtain Warranty Performance:

Replacement parts & service are available from Coleman Powermate's Master Representative service network. Locate the nearest service location by calling 1-800-445-1805, or write: Coleman Powermate Inc., 4970 Airport Road, PO Box 6001, Kearney NE 68848.

To the extent any provision of this warranty is prohibited by federal, state, or municipal law, and cannot be preempted, it shall not be applicable. This warranty gives you specific rights, and you may have other rights which may vary from state to state.

PARTS DRAWING - EXHAUST SYSTEM
PLAN DES PIÈCES - SYSTÈME D'ÉCHAPPEMENT \ DIAGRAMA DE PIEZAS - SISTEMA DE ESCAPE

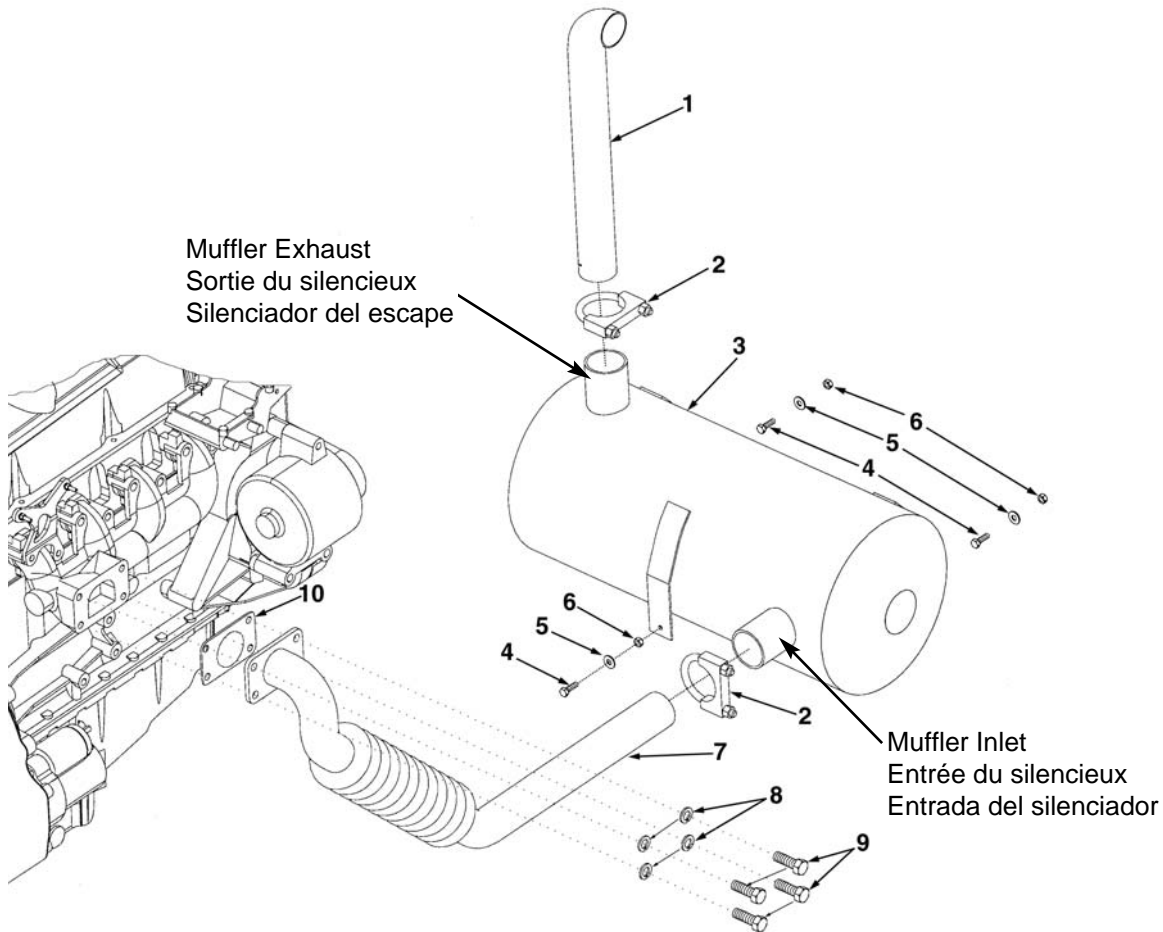

PARTS LIST
LISTE DES PIÈCES \ LISTA DE PIEZAS

Item Article Artículo	Part No Pièce N° N.° De Pieza	Qty Qté	Description	Description	Descripción
1	0058015	1	Tailpipe	Embout d'échappement	Tubo trasero
2	0058016	2	Saddle clamp 2.125"	Bride 2,125"	Abrazadera 2.125"
3	0058013	1	Muffler	Silencieux	Silenciador
4	N/A	3	Bolt, 1/4-20	Boulon, 1/4-20	Perno, ¼-20
5	N/A	3	Washer, 1/4"	Rondelle, 1/4"	Arandela, ¼"
6	N/A	3	Nut, Hex 1/4-20	Écrou hex. 1/4-20	Tuerca, hexagonal ¼-20
7	145-0411	1	Exhaust tube	Tuyau d'échappement	Tubo de escape
8	N/A	4	Lock washer 1/2"	Rondelle de sûreté 1/2"	Arandela de seguridad, 1/2"
9	061-0183	4	Bolt, 1/2-13 x 1-1/2" LG	Boulon, 1/2-13 x 1-1/2" long	Perno, ½-13X1-1/2" LG
10	0058212	1	Exhaust gasket	Joint d'échappement	Junta de escape
11	026-0357	1	Exhaust tube wrap	Enveloppe de tuyau d'échappement	Cubierta del tubo de escape (no (Not shown in drawing) (non illustré) aparece en el esquema)
12	0056778	6	Clamp, stainless steel, for exhaust wrap (Not shown in drawing)	Bride, acier inoxydable, pour enveloppe de tuyau d'échappement	Abrazadera, acero inoxidable, para cubierta del escape (non illustré) (no aparece en el esquema)

*N/A - These are standard parts available at your local hardware store.
 *N/A - N/D - Ces pièces standards se vendent dans les quincailleries.
 *N/A - No procede - Éstas son piezas estándar que se pueden adquirir en una tienda local.

PARTS DRAWING - ENCLOSURE
PLAN DES PIÈCES - BOÎTIER \ DIAGRAMA DE PIEZAS - CARCASA

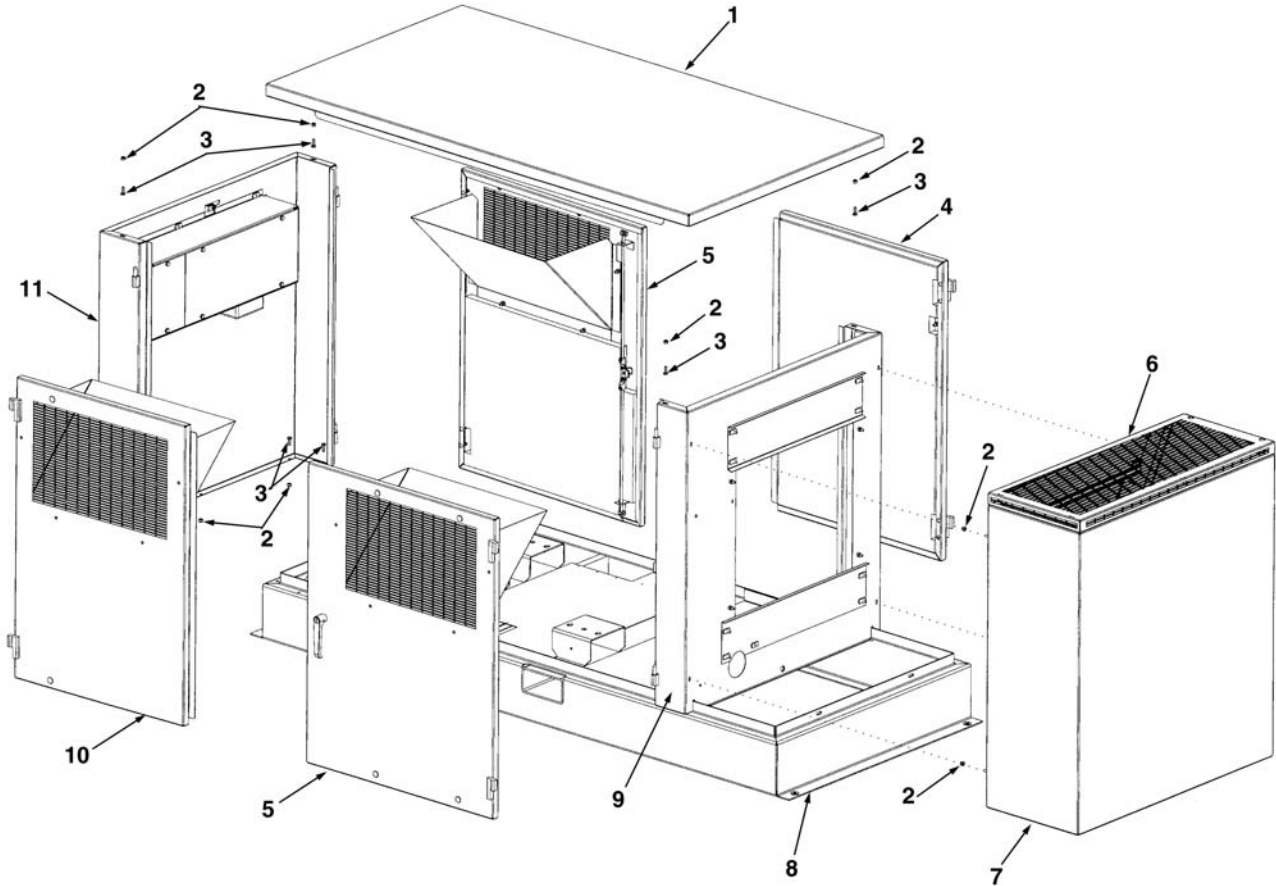

PARTS LIST
LISTE DES PIÈCES \ LISTA DE PIEZAS

Item Article Artículo	Part No Pièce N° N.º De Pieza	Qty Qté Cantidad	Description	Description	Descripción
1	115-0206	1	Lid assembly (includes lid and sound proofing material).	Couvercle (incluant l'isolant sonore)	Conjunto de tapa (incluye la tapa y el material a prueba de ruidos)
2	N/A	12	Nut, nylon stop 1/4-20	Écrou, blocage de nylon 1/4-20	Tuerca, tope de nilón ¼-20
3	N/A	12	Bolt, 1/4-20 X .75	Boulon, 1/4-20 X 0,75	Perno. ¼-20 X 0.75
4	115-0207	1	Door assembly, inner - no inlet (includes hinges, door and sound proofing material)	Ensemble de porte, intérieure - sans prise d'air (incluant charnières, porte et isolant sonore)	Conjunto de puerta, interior - sin entrada (incluye bisagras, puerta y material a prueba de ruido)
5	115-0208	2	Door assembly, outer inlet (includes hinges, door, scoop, latch assembly and sound proofing material)	Ensemble de porte, extérieure (incluant charnières, porte, prise d'air, verrou et isolant sonore)	Conjunto de puerta, entrada exterior (incluye bisagras, puerta, cazo, pestillo y material a prueba de ruido)
6	115-0209	1	Exhaust cover panel	Panneau couvre-échappement	Panel de cubierta del escape
7	115-0210	1	End panel	Panneau d'extrémité	Panel terminal
8	**	1	Frame	Châssis	Estructura
9	115-0211	1	Radiator panel	Panneau de radiateur	Panel del radiador
10	115-0212	1	Door assembly, inner inlet (includes hinges, door, scoop, and sound proofing material)	Ensemble de porte, intérieure à prise d'air (incluant charnières, porte, prise d'air et isolant sonore)	Conjunto de puerta, entrada interior (incluye bisagras, puerta, cazo y material a prueba de ruido)
11	115-0213	1	End panel assembly	Ensemble de panneau d'extrémité	Conjunto de panel terminal
	094-0065	1	Black sound proofing material (31" x 60" (not shown))	Matériau d'isolant sonore noir (31" x 60" (non illustré))	Material a prueba de ruidos de color negro 31" x 60" (no se muestra)

*N/A - These are standard parts available at your local hardware store.

*N/A - N/D - Ces pièces standards se vendent dans les quincailleries.

*N/A - No procede - Éstas son piezas estándar que se pueden adquirir en una tienda local.

** - Not a replacement item.

** - N'est pas une pièce de rechange.

** - No es una pieza de recambio

PARTS DRAWING - COOLING SYSTEM
PLAN DES PIÈCES - SYSTÈME DE REFROIDISSEMENT
DIAGRAMA DE PIEZAS - SISTEMA DE ENFRIAMIENTO

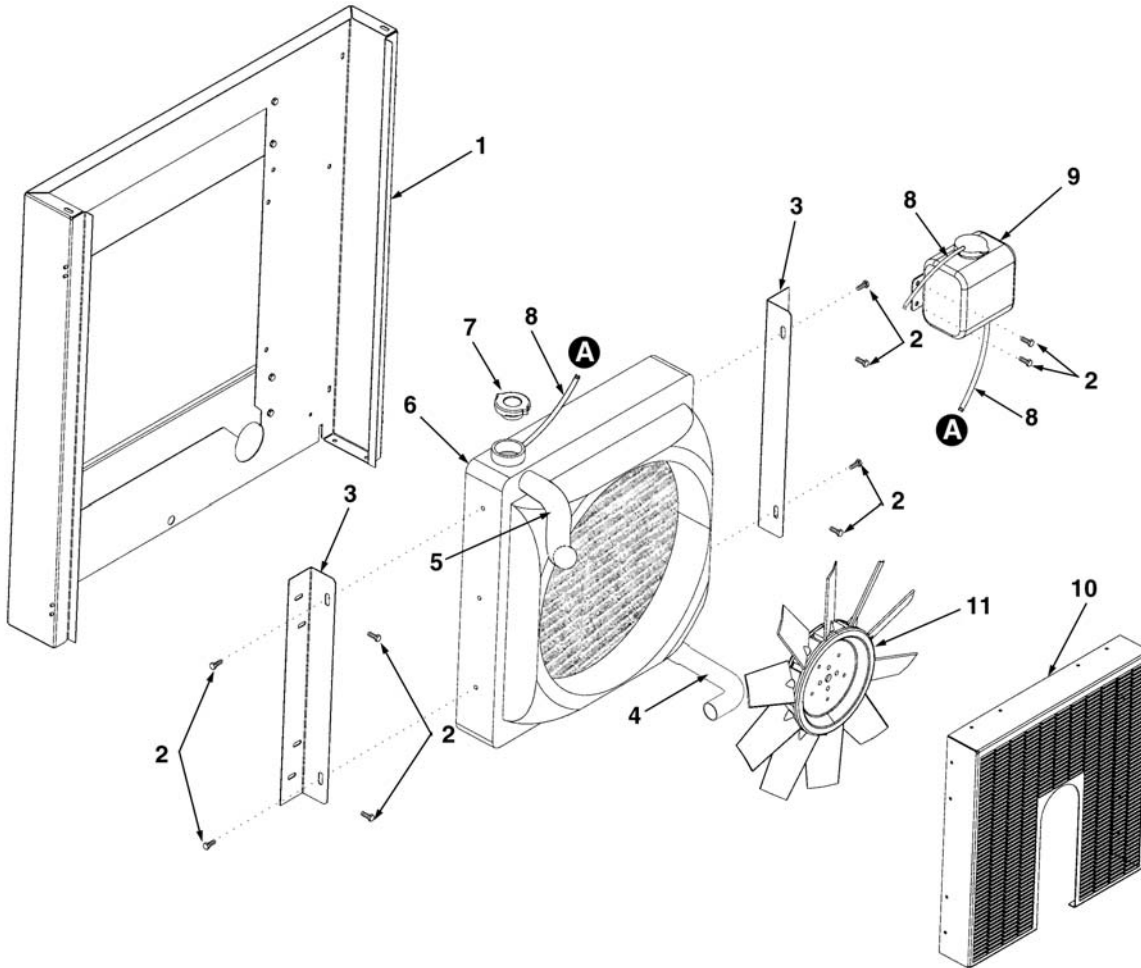

PARTS LIST
LISTE DES PIÈCES \ LISTA DE PIEZAS

Item Article Artículo	Part No Pièce N° N.° De Pieza	Qty Qté Cantidad	Description	Description	Descripción
1	115-0211	1	Radiator panel	Panneau de radiateur	Panel del radiador
2	N/A	10	Bolt, HH 1/4-20 X .75	Boulon, HH 1/4-20 X 0,75	Perno, HH ¼-20 X 0.75
3	S114-0536	2	Radiator bracket	Bride de radiateur	Soporte del radiador
4	0059311	1	Radiator hose, lower	Durite de radiateur, inférieure	Manguera del radiador, inferior
5	0059310	1	Radiator hose, upper	Durite de radiateur, supérieure	Manguera del radiador, superior
6	0058017	1	Radiator	Radiateur	Radiador
7	077-0167	1	Radiator cap, 14 psi	Bouchon de radiateur, 14 psi	Tapa del radiador, 14 psi
8	080-0066	2	Tube, ID 3/16" X 1/16 wall	Tuyau, D.I. 3/16" X 1/16 d'épaisseur	Tubo, pared, DI 3/16" X 1/16
9	0058022	1	Radiator overflow bottle assy.	Bouteille de trop plein de radiateur	Recipiente de rebase del radiador
10	115-0129	1	Radiator fan shield	Écran de ventilateur de radiateur	Protector del ventilador del radiador
11	0058018	1	Fan blade	Hélice de ventilateur	Aspa del ventilador

*N/A - These are standard parts available at your local hardware store.
 *N/A - N/D - Ces pièces standards se vendent dans les quincailleries.
 *N/A - No procede - Éstas son piezas estándar que se pueden adquirir en una tienda local.

PARTS DRAWING - DOOR ASSEMBLY
PLAN DES PIÈCES - ENSEMBLE DE PORTE \ ESQUEMA DE PIEZAS - CONJUNTO DE LA PUERTA

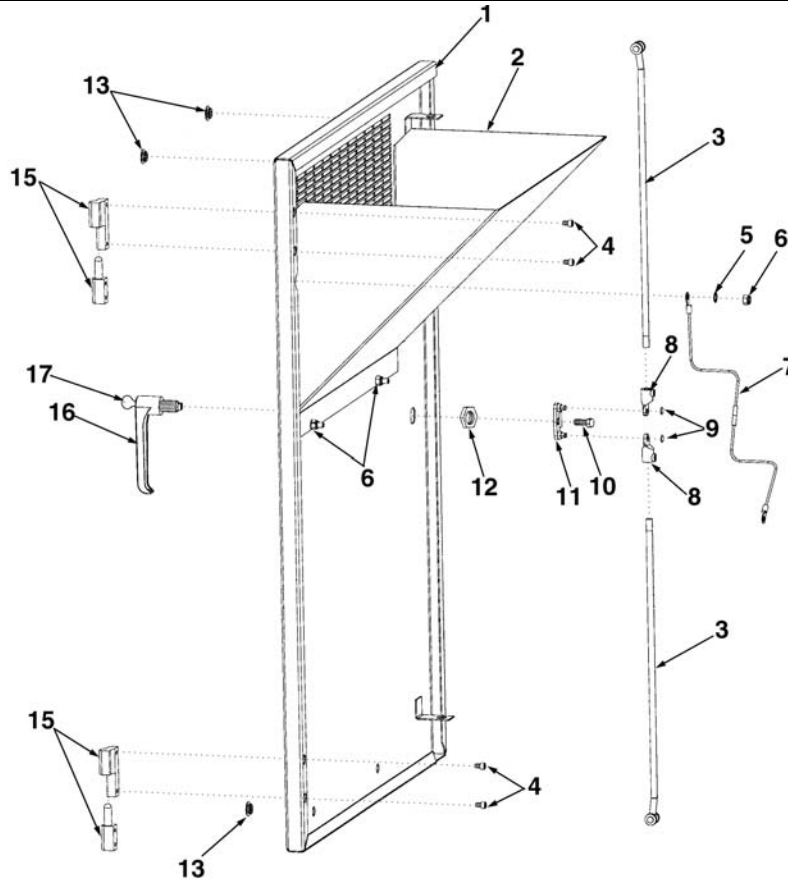

PARTS LIST
LISTE DES PIÈCES \ LISTA DE PIEZAS

Item Article Artículo	Part No Pièce N° N.° De Pieza	Qty Qté Cantidad	Description	Description	Descripción
1	See page 24	1	Door assembly	Ensemble de porte (voir page 24)	Conjunto de puerta (véase página 24)
2	S115-0193	1	Door scoop panel	Panneau de prise d'air de porte	Panel del cazo de la puerta
3	053-0090	2	Roller rod, locking	Tige de verrouillage	Varilla del rodillo, cerradura
4	0058221	4	Screw, M5-.8 x 8MM	Vis, M5-0,8 x 8MM	Tornillo, M5- .8 x 8 MM
5	060-0153	1	Star washer 1/4"	Rondelle à dents 1/4"	Arandela de estrella, 1/4"
6	N/A	4	Nut, nylon stop 1/4-20	Écrou, blocage de nylon 1/4-20	Tuerca, tope de nilón 1/4-20
7	026-0453	1	Ground wire assembly	Ensemble de fil de terre	Conjunto de cable de conexión a tierra
8	053-0091	2	Rod adapter	Adaptateur de tige	Adaptador de varilla
9	Order item #11	2	Retaining ring	Anneau de retenu (commander article n°11)	Anillo de retén
10	Order item #16	1	Bolt	Boulon (commander article n°16)	Perno (Pida el artículo N.° 16)
11	112-0111	1	2 Point rod control (includes item # 9 qty. 2)	Contrôle de tige 2 points (incluant article n° 9, qté 2)	Control de varilla de 2 puntas (incluye el artículo N.° 9. Cantidad 2)
12	Order item #16	1	Nut	Écrou (commander article n°16)	Tuerca (Pida el artículo N.° 16)
13	093-0049	4	Grommet	Passe-fil	Ojal
14	0058035	2	Door hinge assembly LH surface screw on (not shown)	Ensemble de charnières - Main gauche - vis de surface posées (non illustré)	Conjunto de bisagra de puerta, Izq. Tornillo de superficie incorporado (no se muestra)
15	0058036	2	Door hinge assembly RH surface screw on	Ensemble de charnières - Main droite - vis de surface posées (non illustré)	Conjunto de bisagra de puerta Der. Tornillo de superficie incorporado.
16	112-0110	1	Door latch handle (includes items #s 10, 12 and 17)	Poignée de porte (incluant articles n° 10, 12 et 17)	Asa del pestillo de la puerta (incluye los artículos N.° 10, 12, 17)
17	146-0022	1	Key (Dirak 1333)	Clé (Dirak 1333)	Llave (Dirak 1333)

*N/A - These are standard parts available at your local hardware store.

*N/A - N/D - Ces pièces standards se vendent dans les quincailleries.

*N/A - No procede - Éstas son piezas estándar que se pueden adquirir en una tienda local.

PARTS DRAWING - FUEL SYSTEM
PLAN DES PIÈCES - SYSTÈME D'ADMISSION \ DIAGRAMA DE PIEZAS - SISTEMA DE COMBUSTIBLE

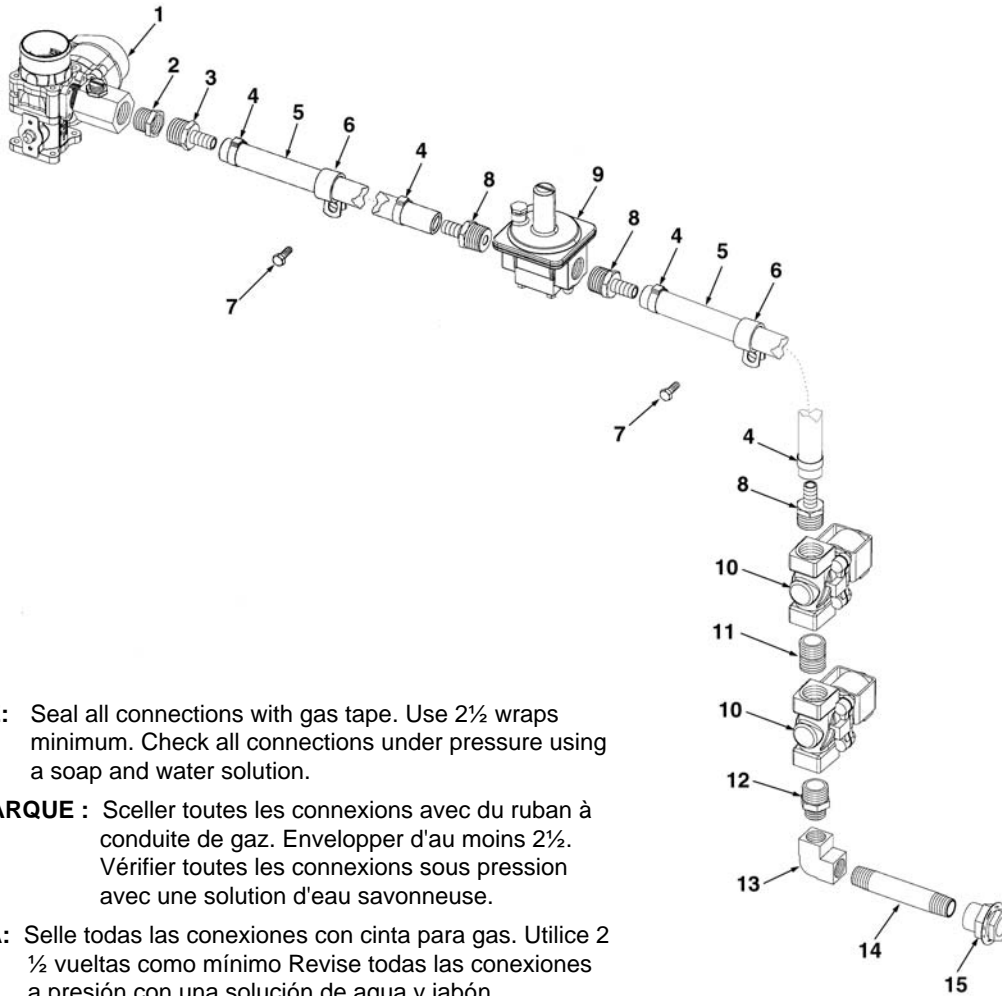

NOTE: Seal all connections with gas tape. Use 2½ wraps minimum. Check all connections under pressure using a soap and water solution.

REMARQUE : Sceller toutes les connexions avec du ruban à conduite de gaz. Envelopper d'au moins 2½. Vérifier toutes les connexions sous pression avec une solution d'eau savonneuse.

NOTA: Selle todas las conexiones con cinta para gas. Utilice 2 ½ vueltas como mínimo Revise todas las conexiones a presión con una solución de agua y jabón.

PARTS LIST
LISTE DES PIÈCES \ LISTA DE PIEZAS

Item Article Artículo	Part No Pièce N° N.° De Pieza	Qty Qté Cantidad	Description	Description	Descripción
1	0058020	1	Mixer/Governor LCS50	Mélangeur/régulateur LCS50	Mezclador/regulador LCS50
2	N/A	1	Bushing, 1/2" x 3/8"	Manchon, 1/2" x 3/8"	Buje, ½" x 3/8"
3	0057747	1	Fitting, 3/8" NPT x 1/2" barb	Raccord, 3/8" NPT x 1/2" cannelé	Acoples, 3/8" NPT x ½" dentados
4	012-0098	4	Hose clamp, 1" ID	Bride de tuyau, D.I. 1"	Abrazadera de manguera, 1" ID
5	012-0091	2	Hose, vapor .51 ID	Tuyau, vapeur D.I. 0,51	Manguera, vapor 0.51 ID
6	0058274	4	Clamp, P .938	Bride, P 0,938	Abrazadera, P 0.938
7	N/A	2	Bolt, HH 1/4-20 X .75	Boulon, HH 1/4-20 X 0,75	Perno, HH ¼-20 X 0.75
8	068-0076	3	Fitting, 3/4" NPT x 1/2" barb	Raccord, 3/4" NPT x 1/2" cannelé	Acoples, 3/4" NPT x ½"
9	019-0203	1	Regulator LPG/NG	Régulateur GPL/GN	Regulador LPG/NG
10	0057345.01	2	Solenoid LPG/NG 3/4" NPT	Solénoïde GPL/GN 3/4" NPT	Solenoido LPG/NG ¾" NPT
11	N/A	1	Nipple, 3/4 NPT x 2" LG	Mamelon, 3/4 NPT x 2" long	Niple, ¾ NPT x 2" LG
12	0056757	1	Nipple, hex reducing 3/4" x 1/2" NPT	Mamelon, réduction hex. 3/4" x 1/2" NPT	Niple, hexagonal reductor 3/4" x ½"
13	064-0069	1	Elbow, brass 1/2" NPT	Coude, laiton 1/2" NPT	Codo, bronce ½" NPT
14	N/A	1	Nipple, 4-1/2" long x 1/2" NPT	Mamelon, 4-1/2" long x 1/2" NPT	Niple, 4-1/2" largo x ½" NPT
15	0058053	1	Bulkhead fitting, 1/2" x 1/2" NPT	Passage étanche, 1/2" x 1/2" NPT	Acople, tapón, ½" x ½" NPT

*N/A - These are standard parts available at your local hardware store.
 *N/A - N/D - Ces pièces standards se vendent dans les quincailleries.
 *N/A - No procede - Éstas son piezas estándar que se pueden adquirir en una tienda local.

PARTS DRAWING - GENERATOR
PLAN DES PIÈCES - GÉNÉRATRICE \ DIAGRAMA DE PIEZAS - GENERADOR

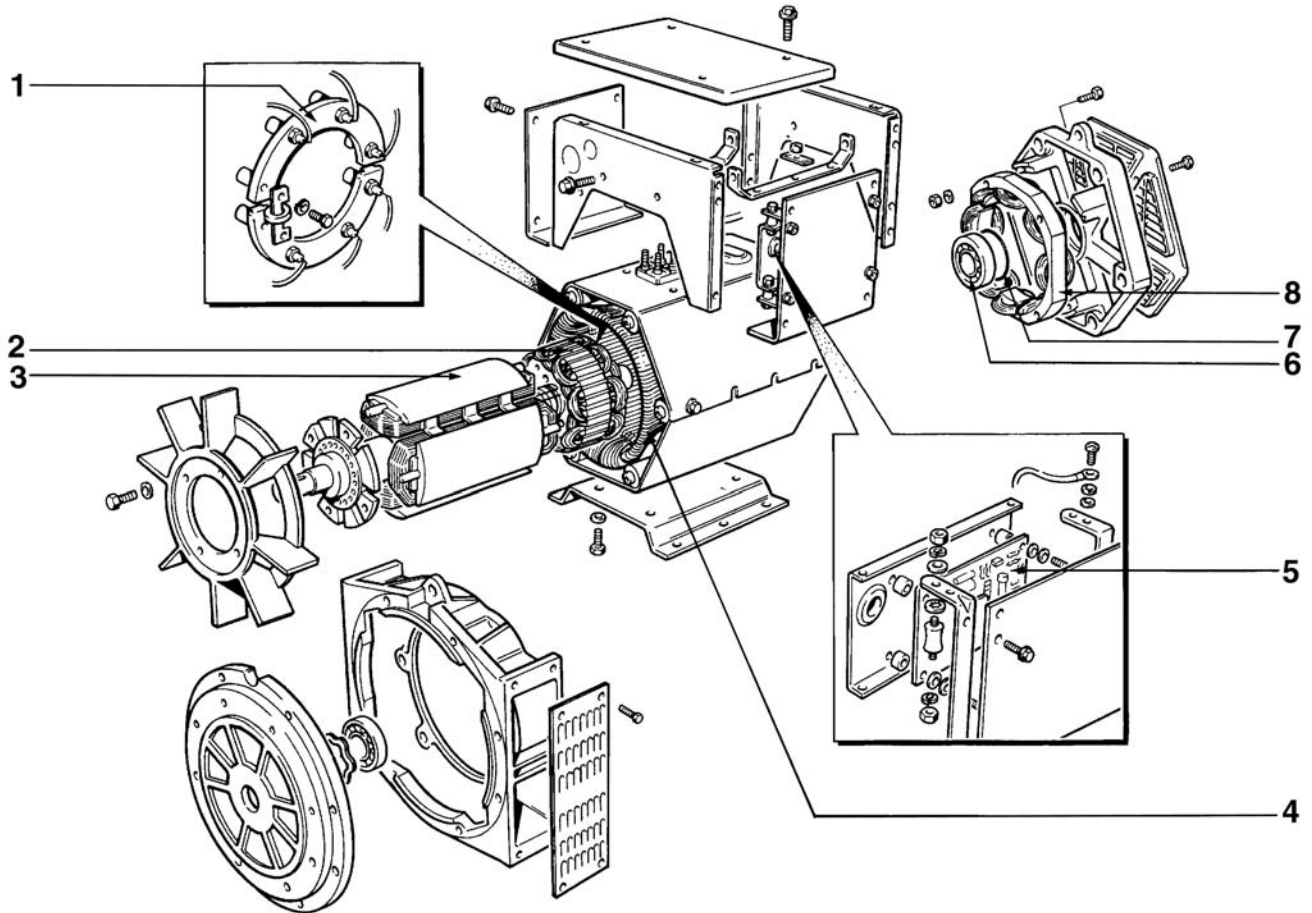

PARTS LIST
LISTE DES PIÈCES \ LISTA DE PIEZAS

Item Article Artículo	Part No Pièce N° N.° De Pieza	Qty Qté Cantidad	Description	Description	Descripción
1	0059337	1	Rectifier service kit w/var, dio	Ens. de réparation redresseur	Juego de rectificación
			avec var., diode		
2	0059183	1	Exciter rotor	Rotor d'excitation	Rotor excitador
3	0059182	1	Complete rotor	Rotor complet	Rotor completo
4	0059181	1	Complete main stator	Stator principal complet	Estator principal completo
5	0059190	1	AVR	Régulateur de tension (AVR)	AVR
6	0059186	1	Bearing N.D.E.	Roulement N.D.E.	Cojinete N.D.E.
7	0059185	1	Bearing 'O' ring N.D.E.	Joint torique de roulement N.D.E.	Junta tórica de cojinete N.D.E.
8	0059184	1	Exciter stator	Stator d'excitation	Estator del excitador

PARTS DRAWING - 25KW BREAKDOWN
PLAN DES PIÈCES - VUE ÉCLATÉE 25 KW
DIAGRAMA DE PIEZAS - DESGLOSE DEL MODELO DE 25 KILOVATIOS

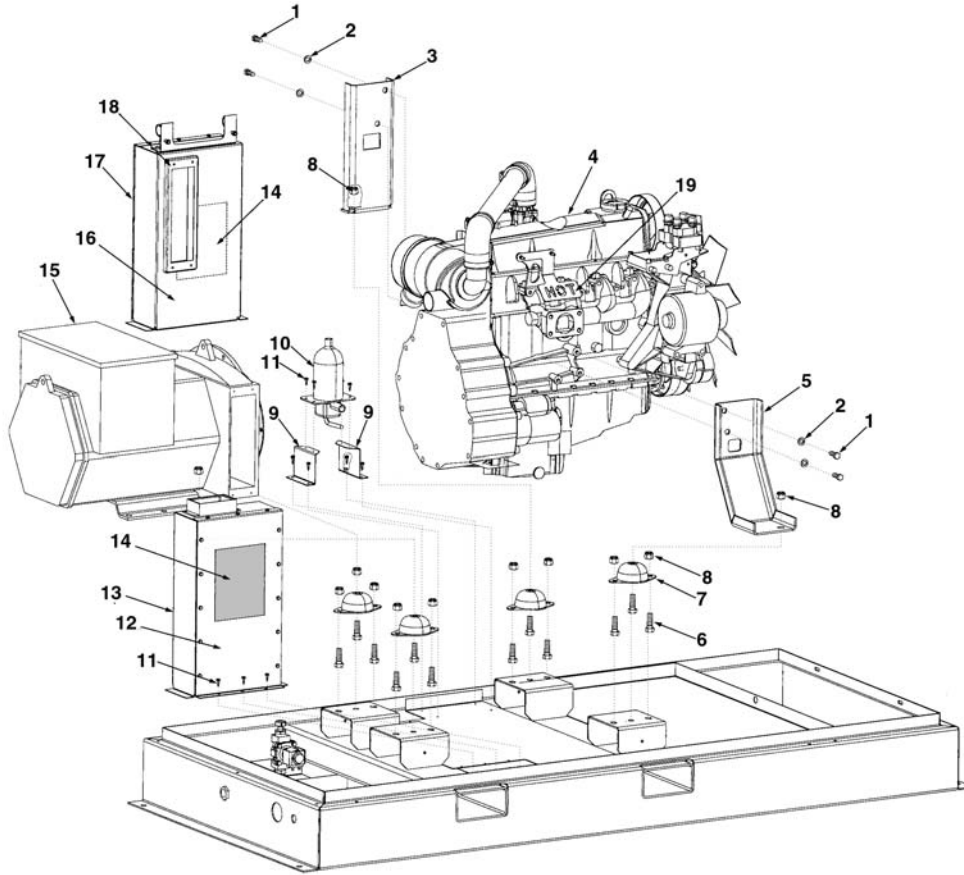

PARTS LIST
LISTE DES PIÈCES \ LISTA DE PIEZAS

Item Article Artículo	Part No Pièce N° N.° De Pieza	Qty Qté Cantidad	Description	Description	Descripción
1	059-0332	4	Bolt, M10-1.5 X 25MM	Boulon, M10-1,5 X 25MM	Perno, M10 - 1.5 x 25 MM
2	060-0163	4	Washer, Lock 7/16 ZP	Rondelle de blocage 7/16 ZP	Arandela, seguridad 7/16 ZP
3	S115-0144	1	Engine mount, filter side	Support de moteur, côté filtre	Montaje del motor, lado del filtro
4	025-0054	1	Engine, Ford LRG425	Moteur, Ford LRG425	Motor, Ford LRG425
5	S115-0145	1	Engine mount, exhaust side	Support de moteur, côté échappement	Montaje del motor, lado del escape
6	059-0335	12	Bolt, 1/2-13 x 1.50	Boulon, 1/2-13 X 1,50	Perno, 1/2 -13 X 1.50
7	0058039	4	Isolator, 225LB	Isolateur, 225 livres	Aislador, 225LB
8	N/A	12	Nut, nyloc 1/2-13	Écrou, blocage de nylon 1/2-13	Tuerca, nilón ½ -13
9	S114-0517	2	Bracket, block heater	Support, chauffe-moteur	Soporte, calefactor del bloque
10	002-0057	1	Circulation heater	Chaufferette à circulation	Calefactor de circulación
11	061-0167	30	Screw, #10-14 X .63	Vis, #10-14 X 0,63	Tornillo, N.º 10 - 14 X 63
12	S115-0140	1	Exhaust plenum cover, exhaust side	Couvercle de gaine d'échappement, côté échappement	Cubierta del pleno del escape, lado del escape
13	115-0125	1	Exhaust plenum, exhaust side	Gaine d'échappement, côté échappement	Pleno del escape, lado del escape
14	098-2633	2	Label, warning	Étiquette de mise en garde	Etiqueta, advertencia
15	0058012	1	Generator head, Newage (see page 28 for parts breakdown)	Tête de génératrice, Newage (voir page 28 pour détail des pièces)	Culata del generador, Newage (consulte página 28 para ver el desglose de piezas)
16	115-0126	1	Exhaust plenum, filter side	Gaine d'échappement, côté filtre	Pleno del escape, lado del filtro
17	S115-0137	1	Exhaust plenum cover, filter side	Couvercle de gaine d'échappement, côté filtre	Cubierta del pleno del escape, lado del filtro
18	115-0138	2	Exhaust plenum plate	Plaque de gaine d'échappement	Placa del pleno del escape
19	098-2694	1	Label, warning "HOT" metal	Étiquette de mise en garde, métal CHAUD	Etiqueta, advertencia metal "CALIENTE"

*N/A - These are standard parts available at your local hardware store.

*N/A - N/D - Ces pièces standards se vendent dans les quincailleries.

*N/A - No procede - Éstas son piezas estándar que se pueden adquirir en una tienda local.

PARTS DRAWING - CONTROL PANEL END ASSEMBLY
PLAN DES PIÈCES - ENSEMBLE DE TABLEAU DE COMMANDE
DIAGRAMA DE PIEZAS - CONJUNTO TERMINAL DEL PANEL DE CONTROL

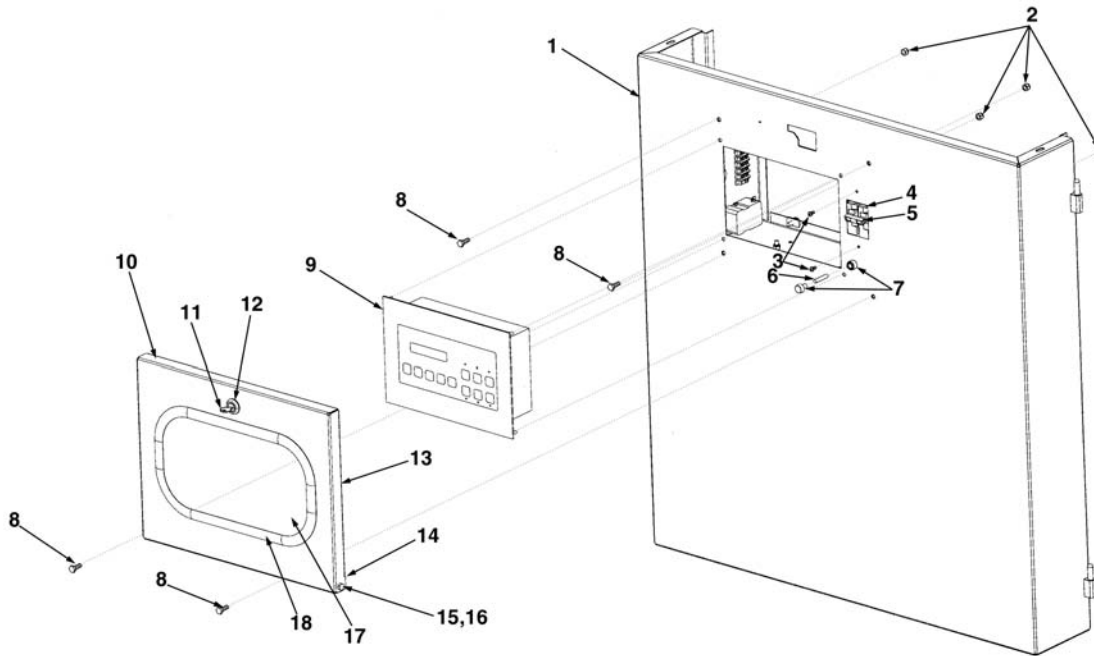

PARTS LIST
LISTE DES PIÈCES \ LISTA DE PIEZAS

Item Article	Part No Pièce N°	Qty Qté	Description	Description	Descripción
1	115-0213	1	Generator end panel	Panneau d'extrémité de la génératrice	Panel terminal del generador
2	N/A	4	Nut, 1/4-20, Nylon stop	Écrou, blocage de nylon 1/4-20	Tuerca, ¼ - 20, tope de nilón
3	N/A	2	Screw, #8-32 x 1/4"	Vis, #8-32 x 1/4"	Tornillo, N.º 8 -32 X ¼"
4	0058069	1	Circuit breaker mounting bracket (not shown) (Includes (2) of item #3)	Bride de montage de disjoncteur (non illustré) (comprend (2) articles n° 3)	Soporte de montaje del interruptor (no se muestra) (incluye 2 del artículo N.º 3)
5**	0058068	1	Circuit breaker, 110A, 120/240V (see ** note below)	Disjoncteur, 110A, 120/240V (voir ** remarque ci-dessous)	Interruptor, 110 amperios, 120/240 voltios (véase ** nota más abajo)
6	0056998	1	Fuse, 10A 250V	Fusible, 10A 250V	Fusible, 10 amperios, 250 voltios
7	026-0309	1	Fuse holder, .25 rt angle	Porte-fusible, 0,25 rt en angle	Porta fusibles, ángulo 25 rt.
8	N/A	4	Bolt, 1/4-20 x .75	Boulon, 1/4-20 X 0,75	Perno, 1/4 -20 X 0.75
9	026-0488 or 026-0439	1	Controller, CP-500 (PROG 1PH 240V) Controller, CP-1000	Contrôleur, CP-500 (1PH 240V) Contrôleur, CP-1000	Controlador, CP-500 (1PH 240V) Controlador, CP-1000
10	115-0205	1	Control panel door assembly (includes items 11-18)	Ensemble de porte de tableau de commande (comprend articles 11 à 18)	Conjunto de la puerta del panel de control (incluye los artículos 11-18)
11	146-0022	1	Key (Dirak 1333)	Clé (Dirak 1333)	Llave (Dirak 1333)
12	Order item #10	1	Lock, 1/4 turn pawl	Verrou, 1/4 de tour (no° 10)	Cerradura, retén de ¼ vuelta (N.º 10)
13	Order item #10	1	Control panel door	Porte du tableau de commande (no° 10)	Puerta del panel de control (N.º 10)
14	Order item #10	1	Control panel door hinge (not shown)	Charnières de porte du tableau de commande (non illustré) (no° 10)	Bisagra de la puerta del panel de control (no se muestra) (N.º 10)
15	N/A	2	Bolt, HH 1/4-20 x .75	Boulon, HH 1/4-20 X 0,75	Perno, HH ¼-20 X 0.75
16	N/A	2	Nut, 1/4-20, Nylon stop	Écrou, blocage de nylon 1/4-20	Tuerca, ¼ - 20, tope de nilón
17	Order item #10	1	Control panel door window	Fenêtre de porte du tableau de commande(no° 10)	Ventana de la puerta del panel de control (N.º 10)
18	Order item #10	1	Control panel door window seal	Joint de fenêtre de porte du tableau de commande (no° 10)	Sello de la ventana de la puerta del panel de control (N.º 10)

*N/A - These are standard parts available at your local hardware store.

*N/A - N/D - Ces pièces standards se vendent dans les quincailleries.

*N/A - No procede - Estas son piezas estándar que se pueden adquirir en una tienda local.

** The circuit breaker to be used with this unit needs to be an U.L. listed, two pole, type BQ, 120/240V RMS, HARC type, circuit breaker rated between 104A and 114A. (Note: 104A is 100% of the LP rating and 114A is 125% of the NG rating.)

** Le disjoncteur à utiliser avec cette unité doit être homologué U.L., à deux pôles, de type BQ, 120/240V RMS, type HARC, d'une capacité de 104A à 114A. (Remarque : 104A correspond à 100 % du courant nominal au GPL et 114A à 125 % du courant nominal au GN.)

** El interruptor a usarse con esta unidad debe ser aprobado por U.L., bipolar, tipo BQ, 120/240 voltios RMS, tipo HARC, entre 104 y 114 amperios. (Nota: 104 A es el 100 % de la clasificación LP y 114 A es el 125 % de la clasificación NG.)

PARTS DRAWING - CONTROL PANEL BREAKDOWN
PLAN DES PIÈCES - VUE ÉCLATÉE DU TABLEAU DE COMMANDE
DIAGRAMA DE PIEZAS - DESGLOSE DEL PANEL DE CONTROL

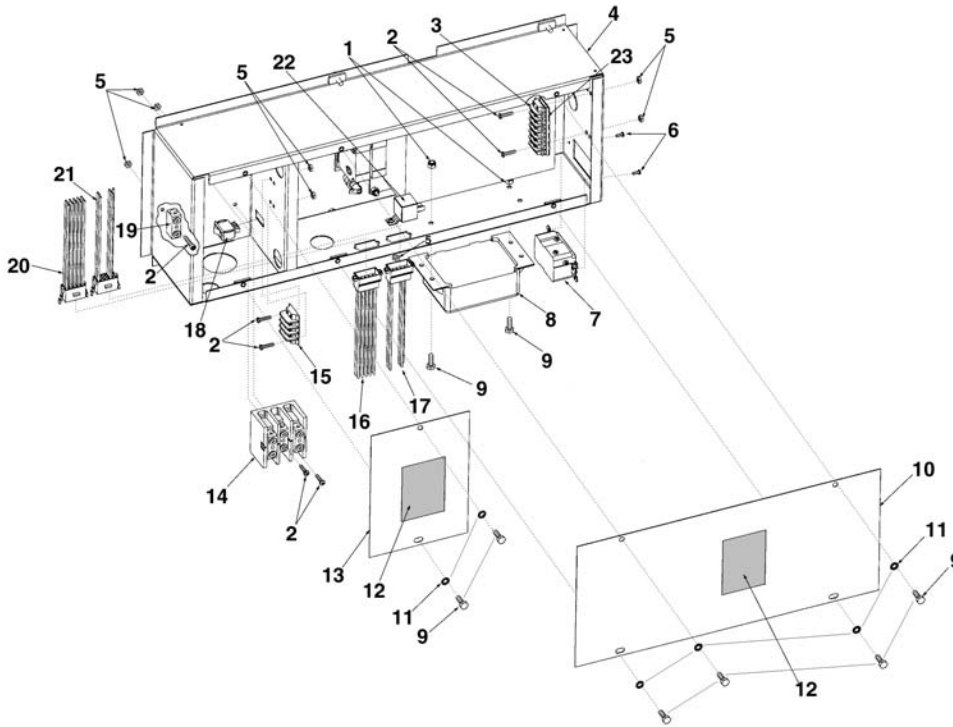

PARTS LIST
LISTE DES PIÈCES \ LISTA DE PIEZAS

Item Article Artículo	Part No Pièce N° N.° De Pieza	Qty Qté	Description	Description	Descripción
1	N/A	4	Nut, 1/4-20 nylon stop	Écrou, blocage de nylon 1/4-20	Tuerca, ¼ - 20, tope de nilón
2	061-0188	10	Screw, TORX 08-32 X 1.25	Vis, TORX 08-32 X 1,25	Tomillo, TORX 08 -32 X 1.25
3	026-0452	1	Terminal block, 2-Row 20A 6-Pole	Plaque de connexion, 2 rangées 20A 6 pôles	Bloque de terminales, 2 hileras, 20 amperios, 6 polos
4	S115-0201	1	Control box	Boîte de contrôle	Caja de control
5	058-0155	13	Nut, HEX #8-32	Écrou hex. #8-32	Tuerca, Hexagonal N.º 8-32
6	**	2	Screw (included with item # 7)	Vis (incluse avec article n° 7)	Tomillo (incluido en el artículo N.º 7)
7	026-0338	1	Receptacle, 5-20R GFCI	Prise, 5-20R GFCI	Receptáculo, 5-20R GFCI
8	0057217	1	Battery charger Gust 2608	Chargeur de batterie Gust 2608	Cargador de baterías Gust 2608
9	N/A	10	Bolt, 1/4-20 X .75	Boulon, 1/4-20 X 0,75	Perno, ¼-20 X 0.75
10	S115-0197	1	Electrical panel cover	Couvercle de panneau électrique	Cubierta del panel eléctrico
11	060-0153	6	Washer, 1/4" Star	Rondelle à dents, 1/4"	Arandela, ¼", tipo estrella
12	098-2702	2	Warning label	Étiquette de mise en garde	Etiqueta de advertencia
13	S115-0198	1	Junction box cover	Couvercle de boîte de jonction	Cubierta de la caja de empalme
14	0058024	1	Terminal block, 2-Row 175A 3-Pole	Plaque de connexion, 2 rangées 175A 3 pôles	Bloque de terminales, 2 hileras, 175 amperios, 3 polos
15	0058025	1	Terminal block, 2-Row 20A 3-Pole	Plaque de connexion, 2 rangées 20A 3 pôles	Bloque de terminales, 2 hileras, 20 amperios, 3 polos
16	026-0411	1	Wire harness, engine	Harnais à fils, moteur	Arnés de cables, motor
17	026-0458	1	Wire harness, generator signal	Harnais à fils, signal de génératrice	Arnés de cables, señal del generador
18	034-0155	1	Rocker switch	Interrupteur à bascule	Interruptor de balancín
19	026-0460	1	Grounding block	Prise de terre	Bloque de conexión a tierra
20	026-0467	1	Wire harness, generator signal, control box	Harnais à fils, signal de génératrice, boîte de contrôle	Arnés de cables, señal del generador, caja de control
21	026-0461	1	Wire harness, control box	Harnais à fils, boîte de contrôle	Arnés de cables, caja de control
22	026-0355	1	Relay DC, 40ANC, .25QC	Relais C.C., 40ANC, .25QC	Relé CC, 40 ANC, .25 QC
23	026-0459	1	Jumper, RJS Type, 6 Section	Cavalier, type RJS, 6 sections	Puente, tipo RJS, sección 6

*N/A - These are standard parts available at your local hardware store.

*N/A - N/D - Ces pièces standards se vendent dans les quincailleries.

*N/A - No procede - Éstas son piezas estándar que se pueden adquirir en una tienda local.

** - Not available separately.

** - Non vendu séparément.

** - No disponible en forma separada.

PARTS DRAWING - BATTERY HOLD DOWN
PLAN DES PIÈCES - FIXATION DE LA BATTERIE
DIAGRAMA DE PIEZAS - SUJECIÓN DE LA BATERÍA

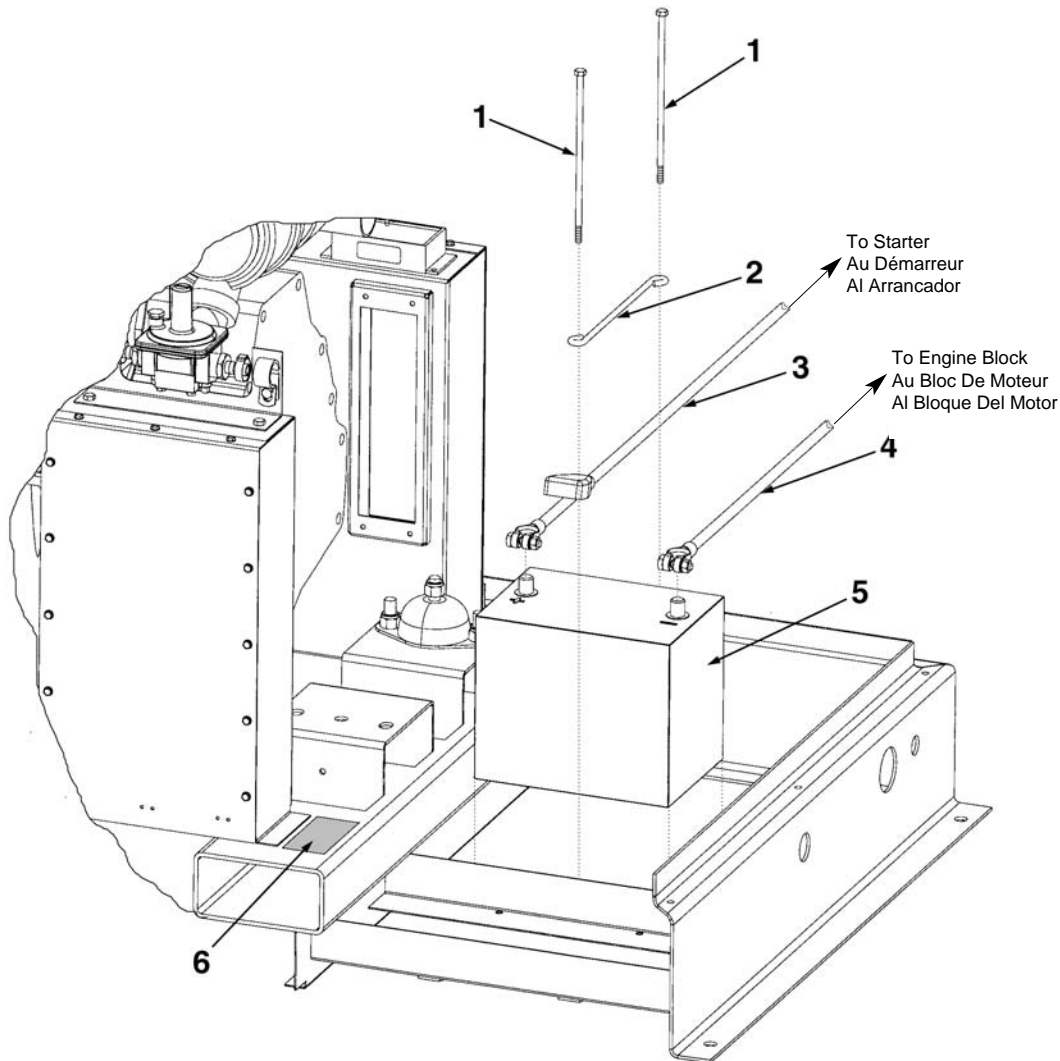

PARTS LIST
LISTE DES PIÈCES \ LISTA DE PIEZAS

Item Article	Part No Pièce N°	Qty Qté	Description	Description	Descripción
Artículo	N.º De Pieza	Cantidad			
1	059-0342	2	Bolt, 1/4-20 X 8.00	Boulon, 1/4-20 X 8,00	Perno, ¼-20 X 8.00
2	114-0508	1	Bracket, battery hold down	Bride, fixation de la batterie	Soporte, sujeción de batería
3	026-0444	1	Battery cable, positive	Câble de batterie, positif	Cable de batería, positivo
4	026-0445	1	Battery cable, negative	Câble de batterie, négatif	Cable de batería, negativo
5	N/A	1	Battery, BCI Group 26 vented	Batterie ventilée, Groupe BCI 26	Batería, Grupo BCI 26 ventilada
6	098-2701	1	Label, warning	Étiquette de mise en garde	Etiqueta, advertencia

*N/A - These are standard parts available at your local hardware store.

*N/A - N/D - Ces pièces standards se vendent dans les quincailleries.

*N/A - No procede - Éstas son piezas estándar que se pueden adquirir en una tienda local.