

INSTALLATION MANUAL

HIGH EFFICIENCY SEALED COMBUSTION GAS FURNACE

MODELS: DGAA and DGAH
(Single Stage Downflow Only)

56 - 90 MBH INPUT
(16.41 - 26.38 KW) INPUT



For Installation In:

1. Manufactured (Mobile) Homes
2. Recreational Vehicles & Park Models
3. Modular Homes & Buildings

LIST OF SECTIONS

SAFETY	1	ELECTRICAL POWER	12
DUCTWORK	4	ROOF JACK VENT/COMBUSTION AIR SYSTEM	13
RETURN AIR REQUIREMENTS	8	SAFETY CONTROLS	20
FILTERS	9	START-UP AND ADJUSTMENTS	20
GAS LINE INSTALLATION	9	WIRING DIAGRAM	26

LIST OF FIGURES

Furnace Dimensions	4	Wiring for Electronic Heat-Cool Thermostat	13
Air Distribution Systems	5	Wiring for Standard Heat-Cool Thermostat	13
Closet To Door Clearance - 5" or Greater	5	Wiring for Blend Air Accessory	13
Furnace To Closet Door Clearance - 1" To 5"	6	Standard Roof Jack	15
Furnace To Closet Door Clearance - Less Than 1"	6	Roof Jack With Removable Crowns	16
Duct Connector Dimensions	6	Roof Jack	17
Recommended Floor Cut-out	7	Connecting Roof Jack to Furnace	17
Duct Connector Depth	7	Roof Jack Assembly	18
Duct Connector Screw Attachment	7	Ceiling Rings	18
Duct Connector Tab Attachment	7	Home Layout	19
Anti-Backflow Damper	8	Pressure Switch Tubing Routing	20
Floor Installation	8	Gas Valve	23
Furnace Air Filters	9	Reading Gas Pressure	24
Gas Piping	10	Furnace Control Board	24
Burner Assembly	10	Wiring Diagram - DGAA	26
Line Wiring Connections	12	Wiring Diagram - DGAH	27
Wiring for Heat Only Thermostat	13		

LIST OF TABLES

Unit Clearances to Combustibles	4	Roof Jack Options	18
External Static Pressure Range	8	Inlet Gas Pressure Range	23
Filter Sizes - All Models	9	Nominal Manifold Pressure	23
High Altitude Duration Chart	12	Blower Performance CFM - Downflow Without Filters	25
Ratings & Physical / Electrical Data	13	AC Accessories	25

SECTION I: SAFETY



This is a safety alert symbol. When you see this symbol on labels or in manuals, be alert to the potential for personal injury.

Understand and pay particular attention to the signal words **DANGER**, **WARNING**, or **CAUTION**.

DANGER indicates an **imminently** hazardous situation, which, if not avoided, **will result in death or serious injury**.

WARNING indicates a **potentially** hazardous situation, which, if not avoided, **could result in death or serious injury**.

CAUTION indicates a **potentially** hazardous situation, which, if not avoided **may result in minor or moderate injury**. It is also used to alert against unsafe practices and hazards involving only property damage.

WARNING

Improper installation may create a condition where the operation of the product could cause personal injury or property damage.

Improper installation, adjustment, alteration, service or maintenance can cause injury or property damage. Refer to this manual for assistance or for additional information, consult a qualified contractor, installer or service agency.

CAUTION

This product must be installed in strict compliance with the installation instructions and any applicable local, state, and national codes including, but not limited to building, electrical, and mechanical codes.

SPECIFIC SAFETY RULES AND PRECAUTIONS

1. Only Natural gas or Propane (LP) gas are approved for use with this furnace. Refer to the furnace rating plate or Section IV of these instructions.
2. Install this furnace only in a location and position as specified in SECTION I of these instructions.
3. A gas-fired furnace for installation in a residential garage must be installed as specified in SECTION I of these instructions.

▲ WARNING**FIRE OR EXPLOSION HAZARD**

Failure to follow the safety warnings exactly could result in serious injury, death or property damage.

Never test for gas leaks with an open flame. Use a commercially available soap solution made specifically for detection of leaks to check all connections. A fire or explosion may result causing property damage, personal injury or loss of life.

4. Test for gas leaks as specified in SECTION IX of these instructions.
5. Always install the furnace to operate within the furnace's intended temperature rise range. Only connect the furnace to a duct system which has an external static pressure within the allowable range, as specified on the furnace rating plate.
6. When a furnace is installed so that supply ducts carry air circulated by the furnace to areas outside the space containing the furnace, the return air may also be handled by duct(s) sealed to the furnace casing and terminating outside the space containing the furnace. The return air duct system is not required by the furnace manufacturer provided the combustion air and vent system have been installed and maintained as a Sealed Combustion Direct Vent System and provided a return air duct system and return air plenum are not required by state, local, or regional codes.

▲ WARNING

Improper installation may damage equipment, can create a shock hazard, and will void the warranty.

The furnace shall be installed so the electrical components are protected from water.

The furnace is not to be used for temporary heating of buildings or structures under construction.

Do not test the fuel system at more than 14 inches water column after furnace has been connected to the fuel line. Such testing may void the warranty. Any test run above 14 inches water column may damage the furnace control valve which could cause an explosion, fire, or asphyxiation.

The following requirements to be met:

- a. Clean, outside combustion air is provided to the furnace to minimize the impact of corrosive adhesives, sealants, and other construction materials. Drywall dust is a major concern during construction, which can be pulled into the combustion air path, leading to plugged heat exchangers, burners, and inducer assemblies.
- b. Filter must be installed in the furnace as specified in the installation instructions, and must be replaced or thoroughly cleaned prior to occupancy of the home. Again, drywall dust is the key issue, as that dust can be pulled into the circulating blower motor, plugging the motor vents, coating the rotors and stators, etc. which can lead to a potential fire hazard.
- c. The temperature of the return air to the furnace must not be less than 55° F (13° C), with no evening setback or furnace shutdown, to prevent condensation in the primary heat exchangers.
- d. The air temperature rise must be within the stated rise range as indicated on the furnace rating plate, and the firing input rate must be set to the unit nameplate value.

- e. The external static pressure of the air distribution system ductwork must be set for heating operation to be at least 0.10 to 0.20 inches water column, based on the input rate of the furnace, with the lower value for input rates less than 55,000 btu/hr and the upper value for units with input rates above 100,000 btu/hr.
- f. The furnace and ductwork should be thoroughly and completely cleaned prior to occupancy of the dwelling to insure the proper operation of the furnace and to avoid potential health concerns.
7. In Canada refer to the Natural Gas and Propane Installation code, section on Central Furnaces. When installed in a Manufactured (Mobile) Home, combustion air shall not be supplied from occupied spaces.
8. The size of the unit should be based on an acceptable heat loss calculation for the structure. ACCA, Manual J or other approved methods may be used.
9. **Manufactured (Mobile) Home and Modular Home Installation:** This appliance must be installed in a (sealed combustion) configuration using a roof jack vent system. A roof jack is only approved vent system that can be used to vent this appliance.
10. **Modular Home Definition:** Factory-built home constructed to the state, local, or regional code where the house will be located. The home is transported in one or more modules and joined at the home site.
11. **Manufactured (Mobile) Home Definition:** Factory-built home constructed, transported and installed under the federal building code administered by the U.S. Department of Housing and Urban Development (HUD Code), rather than to building codes at their destination. The house is built, transported and installed on a non-removable chassis.

SAFETY REQUIREMENTS

- Provide clearances from combustible materials as listed under Furnace Locations and Clearances.
- Provide clearances for servicing ensuring that service access is allowed for both the burners and blower.
- These models are CSA listed and approved for installation into a Modular Home, Manufactured (Mobile) Home, or Recreational Vehicles.
- **Failure to carefully read and follow all instructions in this manual can result in furnace malfunction, death, personal injury and/or property damage.**
- Furnaces for installation on combustible flooring shall not be installed directly on carpeting, tile or other combustible material other than wood flooring.
- Check the rating plate and power supply to be sure that the electrical characteristics match. All models use nominal 115 VAC, 1 Phase, 60-Hertz power supply. **DO NOT CONNECT THIS APPLIANCE TO A 50 HZ POWER SUPPLY OR A VOLTAGE ABOVE 130 VOLTS.**
- Furnace shall be installed so the electrical components are protected from water.
- Installing and servicing heating equipment can be hazardous due to the electrical components and the gas fired components. Only trained and qualified personnel should install, repair, or service gas heating equipment. Untrained service personnel can perform basic maintenance functions such as cleaning and replacing the air filters. When working on heating equipment, observe precautions in the manuals and on the labels attached to the unit and other safety precautions that may apply.
- These instructions cover minimum requirements and conform to existing national standards and safety codes. In some instances these instructions exceed certain local codes and ordinances, especially those who have not kept up with changing Modular Home and Manufactured (Mobile) Home home construction practices. These instructions are required as a minimum for a safe installation.

Manufactured homes in the U.S.A.:

- Federal Manufactured Home Construction & Safety Standard (H.U.D. Title 24, Part 3280).
- National Fuel Gas Code (ANSI-Z223.1, NFPA-54).
- National Electrical Code (NFPA 70).

Manufactured homes in Canada:

- Natural Gas and Propane Installation Code (CAN/CSA B149.1).
- Canadian Electrical Code, Part 1 (CSA C22.1)

Recreational Vehicles in U.S.A.:

- Standard on Recreational Vehicles (NFPA 1192, formerly NFPA 501C).
- National Electrical Code (NFPA 70).

Recreational Vehicles in Canada:

- Unit installation shall comply with current CSA standard CAN/CGA-Z240.4.2 - Installation Requirements for Propane Appliances and Equipment in Recreational Vehicles.
- Unit electrical wiring and grounding shall comply with current CSA standard C22.2 No.148/CAN/CSA-Z240.6.2 - Electrical Requirements for recreational vehicles.

**COMBUSTION AIR QUALITY
(LIST OF CONTAMINANTS)**

The furnace will require **OUTDOOR AIR** for combustion AT ALL TIMES, INCLUDING any of the following environments.

- Restricted Environments
- Commercial buildings
- Buildings with indoor pools
- Laundry rooms
- Hobby or craft rooms
- Near chemical storage areas
- Chemical exposure

This furnace requires **OUTDOOR AIR** for combustion AT ALL TIMES, AS WELL AS where the furnace is being exposed to the following substances and / or chemicals.

- Permanent wave solutions
- Chlorinated waxes and cleaners
- Chlorine based swimming pool chemicals
- Water softening chemicals
- De-icing salts or chemicals
- Carbon tetrachloride
- Halogen type refrigerants
- Cleaning solvents (such as perchloroethylene)
- Printing inks, paint removers, varnishes, etc.
- Hydrochloric acid
- Cements and glues
- Antistatic fabric softeners for clothes dryers
- Masonry acid washing materials

When outdoor air is used for combustion, the combustion air intake duct system termination must be located external to the building and in an area where there will be no exposure to the substances listed above.

WARNING

The furnace area must not be used as a broom closet or for any other storage purposes, as a fire hazard may be created. Never store items such as the following on, near or in contact with the furnace.

1. Spray or aerosol cans, rags, brooms, dust mops, vacuum cleaners or other cleaning tools.
2. Soap powders, bleaches, waxes or other cleaning compounds; plastic items or
3. Containers; gasoline, kerosene, cigarette lighter fluid, dry cleaning fluids or other volatile fluid.
4. Paint thinners and other painting compounds.
5. Paper bags, boxes or other paper products

Never operate the furnace with the blower door removed. To do so could result in serious personal injury and/or equipment damage.

INSPECTION

As soon as the furnace and/or accessories are received, it should be inspected for damage during transit. If damage is evident, the extent of the damage should be noted on the carrier's freight bill. A separate request for inspection by the carrier's agent should be made in writing. Also, before installation the furnace and/or accessories should be checked for screws or bolts which have loosened in transit or shipping and spacer brackets the need to be removed.

FURNACE LOCATION AND CLEARANCES**The furnace shall be located using the following guidelines:**

1. The furnace should be located where the roof jack can be installed with out major modifications to the roof of the structure.
2. As centralized with the air distribution as possible.
3. Where there is access to fresh air particularly when the blend air accessory will be installed.
4. Where it will not interfere with proper air circulation in the confined space.
5. Where the outdoor roof jack terminal will not be blocked or restricted. Refer to "VENT CLEARANCES" located in SECTION VII of these instructions. These minimum clearances must be maintained through out the installation.
6. Where the unit will be installed in a level position with no more than 1/4" (0.64 cm) slope side-to-side and front-to-back to provide a proper roof jack connection and seal.

Installation in freezing temperatures:

1. Furnace shall be installed in an area where ventilation facilities provide for safe limits of ambient temperature under normal operating conditions. Ambient temperatures may fall below 32° F (0° C) providing the flue temperature does not fall below 260° F (127° C) at any point in the flue pipe. If the flue temperature falls below 260° F (127° C) the flue products will condense in the vent pipe causing the vent pipe to deteriorate rapidly.
2. Do not allow return air temperature to be below 55° F (13° C) for extended periods. To do so may cause condensation to occur in the main heat exchanger, leading to premature heat exchanger failure.

WARNING

Installation in an ambient below 32°F (0.0° C) could create a hazard, resulting in damage, injury or death.

3. If this furnace is installed in an unconditioned space and an extended power failure occurs, there will be potential damage to the internal components. Following a power failure situation, do not operate the unit until inspection and repairs are performed.

Clearances for access:

Ample clearances should be provided to permit easy access to the unit. The following minimum clearances are recommended:

1. Twenty-four 24 inches (61 cm) between the front of the furnace and an adjacent wall or another appliance, when access is required for servicing and cleaning.
2. Eighteen 18 inches (46 cm) at the side where access is required for passage to the front when servicing or for inspection or replacement of flue/vent connections.

In all cases, accessibility clearances shall take precedence over clearances for combustible materials where accessibility clearances are greater. See Table 1.

WARNING

Check the rating plate and power supply to be sure that the electrical characteristics match. All models use nominal 115 VAC, 1 Phase 60Hz power supply. Furnace shall be installed so the electrical components are protected from water.

Installation in a residential garage:

A gas-fired furnace for installation in a residential garage must be installed so the burner(s) and the ignition source are located not less than 18 inches (46 cm) above the floor, and the furnace must be located or protected to avoid physical damage by vehicles.

TABLE 1: Unit Clearances to Combustibles

Application	Top		Front		Rear		Sides		Roof Jack Flue		Floor ¹		Duct ¹	
	Closet	Alcove	Closet	Alcove	Closet	Alcove	Closet	Alcove	Closet	Alcove	Closet	Alcove	Closet	Alcove
	In. (cm)	In. (cm)	In. (cm)	In. (cm)	In. (cm)	In. (cm)	In. (cm)	In. (cm)	In. (cm)	In. (cm)	In. (cm)	In. (cm)	In. (cm)	In. (cm)
Downflow	2(50.8)	2(50.8)	6(15.24)	24(60.96)	0	0	0	0	0	0	0	0	0	0

1. Approved duct connector required for use on combustible floor.

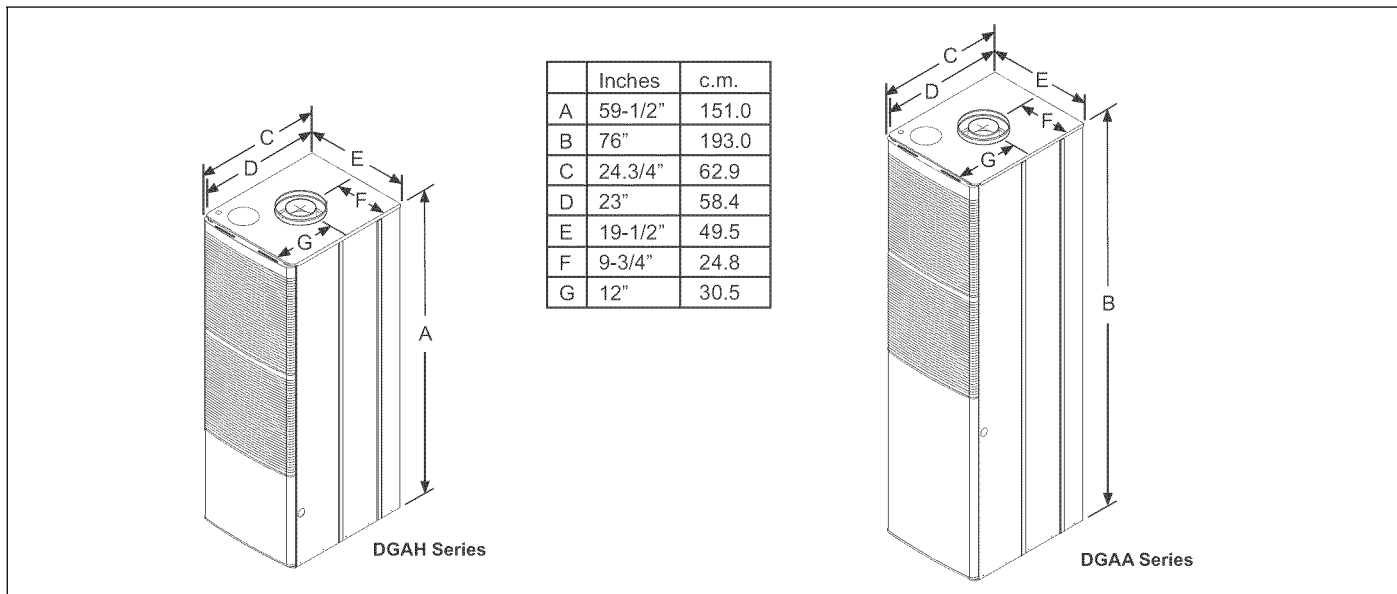

FIGURE 1: Furnace Dimensions

SECTION II: DUCTWORK

DUCTWORK GENERAL INFORMATION

The duct system's design and installation must:

1. Handle an air volume appropriate for the served space and within the operating parameters of the furnace specifications.
2. Be installed in accordance with standards of NFPA (National Fire Protection Association) as outlined in NFPA pamphlets 90A and 90B (latest editions), in Canada CAN/CGA-B149.1-00 Natural Gas and Propane Installation Code, or applicable national, provincial, or state, and local fire and safety codes.
3. **For Manufacture (Mobile) Home and Modular Home Return Duct System Installations:**
The return air duct and the return air plenum are not required by the furnace manufacturer, provided a return air duct and plenum are not required by state, local, or regional codes. The only vent system that is approved for use on this furnace is a Roof Jack which is a Sealed Combustion Direct Vent System.
4. Complete a path for heated or cooled air to circulate through the air conditioning and heating equipment and to and from the conditioned space.

CAUTION

The cooling coil must be installed in the supply air duct, downstream of the furnace. Cooled air may not be passed over the heat exchanger, and must comply with (H.U.D.) TITLE 24, PART 3280.709

When the furnace is used in conjunction with a cooling coil, the coil must be installed parallel with, or in the supply air side of the furnace to avoid condensation in the primary heat exchanger. When a parallel flow arrangement is used, dampers or other means used to control airflow must be adequate to prevent chilled air from entering the furnace. If manually operated, the damper must be equipped with means to prevent the furnace or the air conditioner from operating unless the damper is in full heat or cool position.

WARNING

The duct system must be properly sized to obtain the correct airflow for the furnace size that is being installed. Refer to the furnace rating plate for the correct rise range and Table 4 for static pressures. If the ducts are undersized, the result will be high duct static pressures and/or high temperature rises which can result in a heat exchanger OVERHEATING CONDITION. This condition can result in premature heat exchanger failure, which can result in personal injury, property damage, or death.

WARNING

HAZARD OF ASPHYXIATION, DO NOT COVER OR RESTRICT FLOOR OPENING.

The duct system is a very important part of the installation. If the duct system is improperly sized the furnace will not operate properly. The ducts attached to the furnace plenum, should be of sufficient size so that the furnace operates at the specified external static pressure and within the air temperature rise specified on the nameplate.

IMPORTANT

Fabricate and install an inspection door in the plenum base below the unit to allow an annual inspection of the heat exchangers. The inspection door can be fabricated by the following method.

1. Cut a rectangular opening in the plenum base.
2. A sheet metal plate can be made that completely covers the opening in the base.
3. The plate must be secured with screws.
4. This plate must be sealed to prevent leaks.

⚠ WARNING

The supply air temperature **MUST NEVER** exceed the **Maximum Supply Air Temperature**, specified on the nameplate.

Operating the furnace above the maximum supply air temperature will cause the heat exchanger to overheat, causing premature heat exchanger failure. Improper duct sizing, dirty air filters, incorrect manifold pressure, incorrect gas orifice and/or a faulty limit switch can cause the furnace to operate above the maximum supply air temperature. Refer to sections II, III and XI for additional information on correcting the problem.

DUCTWORK INSTALLATION

Air Distribution Systems

For proper air distribution, the supply duct system shall be designed so that the static pressure does not exceed the listed static pressure rating on the furnace rating plate.

Three typical distribution systems are illustrated in Figure 2.

Location, size and number of registers should be selected on the basis of best air distribution and floor plan of the home.

The Air Temperature Rise is to be adjusted to obtain a temperature rise within the range(s) specified on the furnace rating plate.

DUCT DESIGN - CANADA

Supply duct design shall be in accordance with the latest HRA Digest, the ASHRAE Handbook Fundamentals, or other good engineering principles.

NOTE: Refer to HRA Digest Residential Air System Design Manual, Sections 5 and 6, the requirements of which are summarized as follows:

1. The kilowatt output of each duct register shall not exceed 2.35 kW.
2. The furnace output should not be more than 20% greater than the calculated heat loss of the home. If a larger furnace is used, the duct system shall be capable of the increased air volumes necessary to maintain a maximum air temperature rise of 50° C as the air passes over the furnace heat exchanger.
3. At least one warm air supply outlet shall be provided in each room.
4. When rooms are located adjacent to the exterior walls, warm air outlets shall be located so as to bathe at least one exterior wall and, where practical, a window area with warm air, except for bathrooms or kitchens where this might not be practical.
5. Where practical, outlets shall be provided near the exterior doors of the home.

CLEARANCE REQUIREMENTS - CANADA

Supply air ducts from warm air furnaces having a specified minimum plenum clearance shall maintain this clearance from combustible material for at least the distance specified in CSA Standards C22.2 No. 23 or B140.10 or CGA Standard CAN/CGA-2.3.

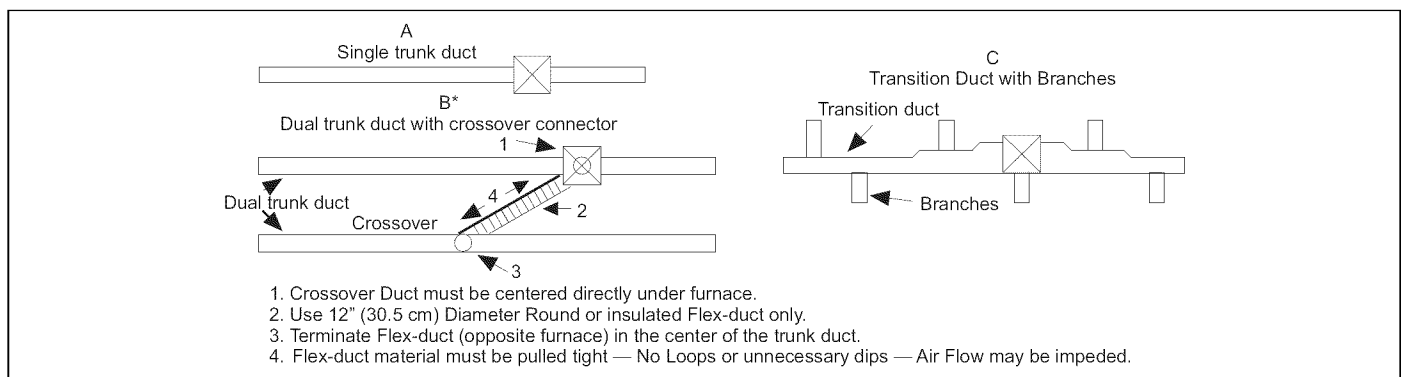

FIGURE 2: Air Distribution Systems

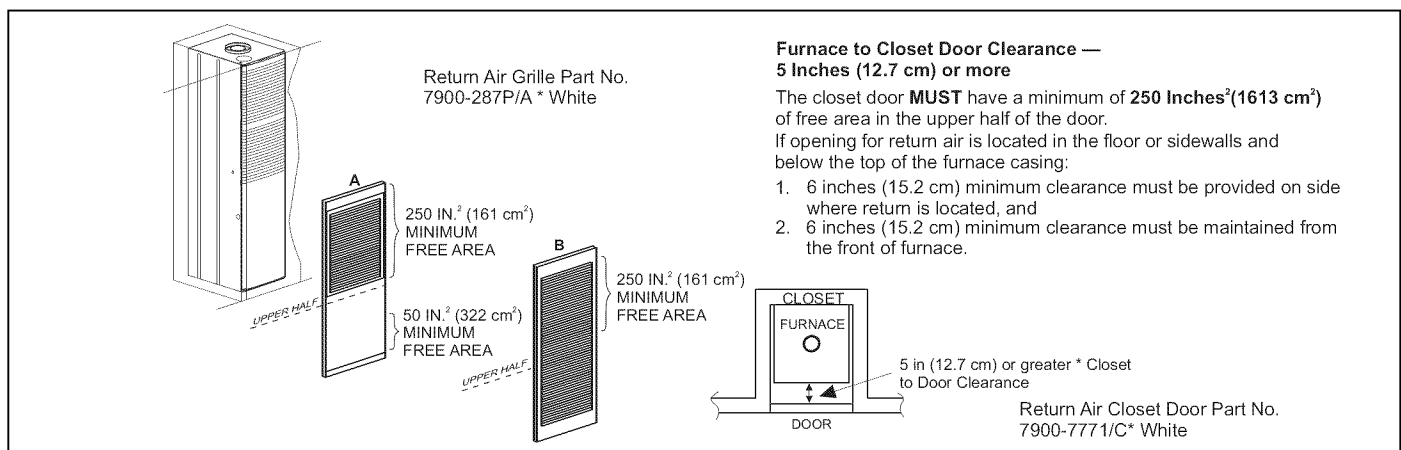

FIGURE 3: Closet To Door Clearance - 5" or Greater

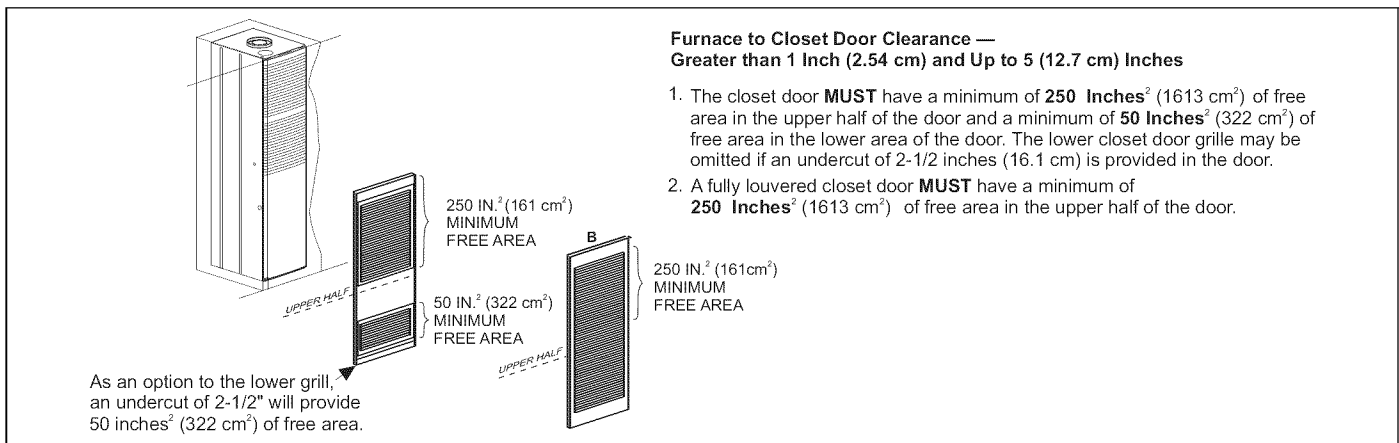

FIGURE 4: Furnace To Closet Door Clearance - 1" To 5"

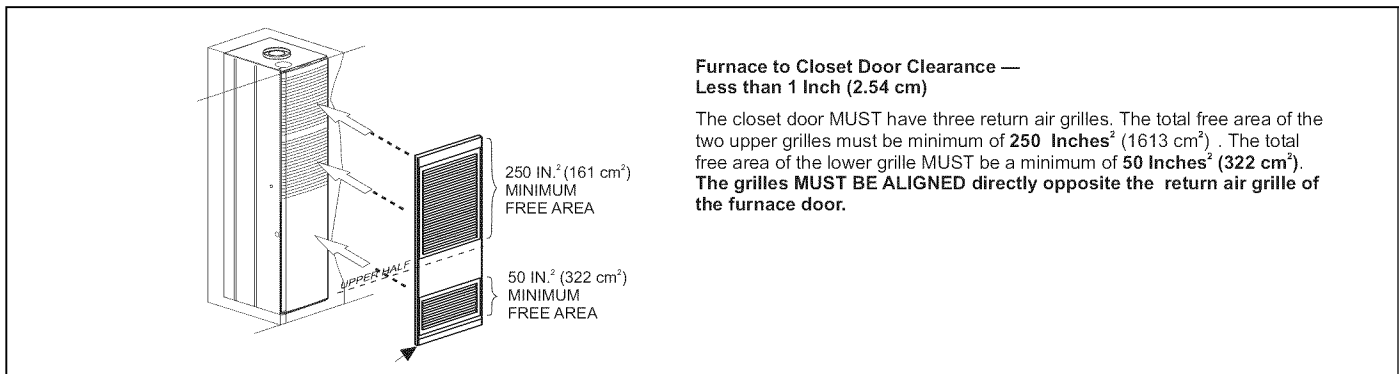

FIGURE 5: Furnace To Closet Door Clearance - Less Than 1"

DUCT CONNECTORS

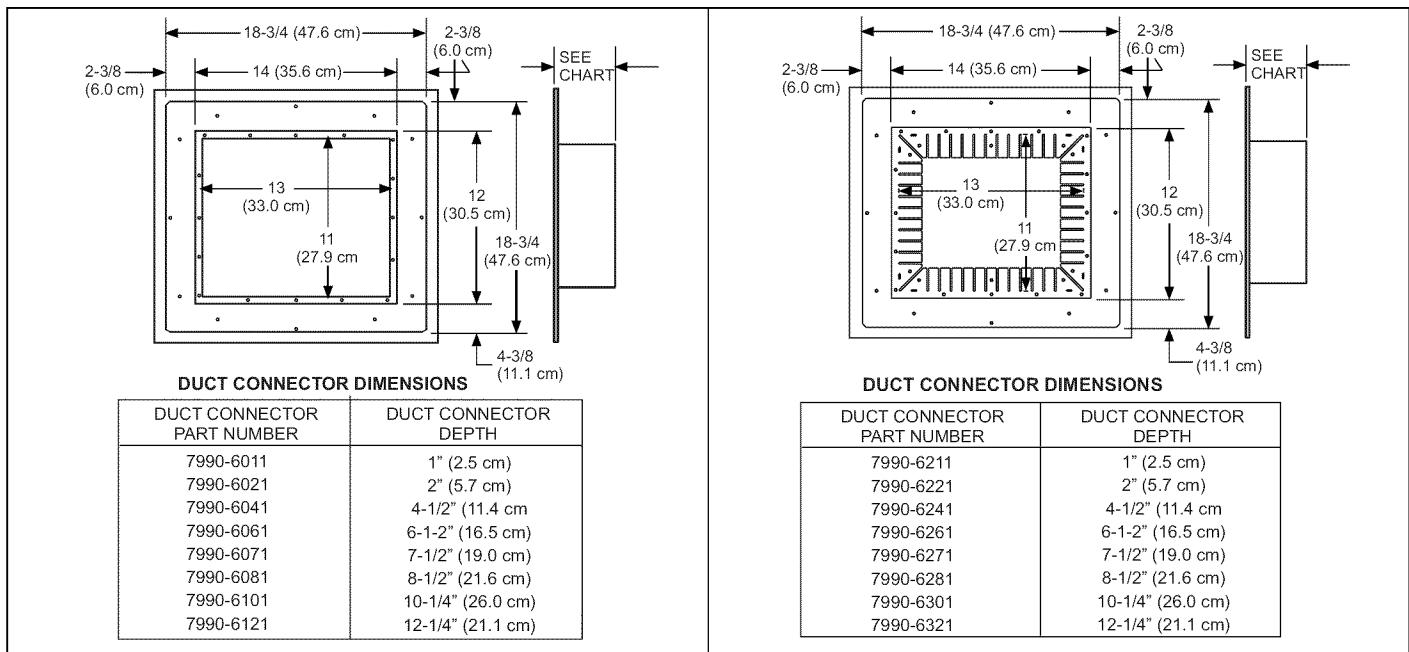

FIGURE 6: Duct Connector Dimensions

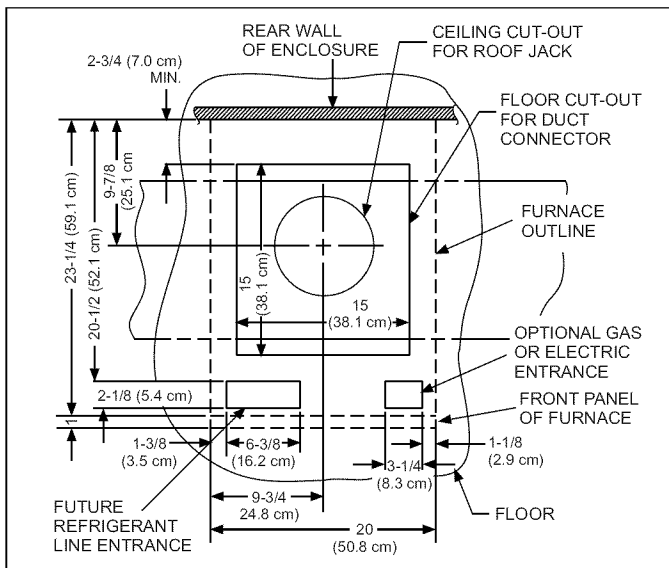

FIGURE 7: Recommended Floor Cut-out

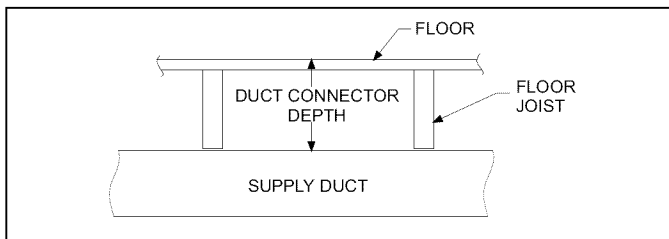

FIGURE 8: Duct Connector Depth

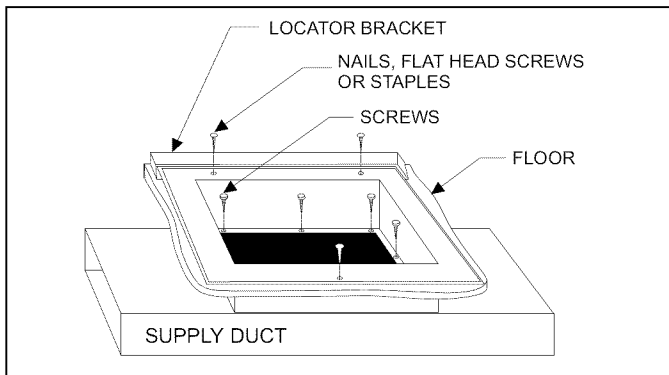

FIGURE 9: Duct Connector Screw Attachment

INSTALLATION OF SCREW ATTACHMENT DUCT CONNECTOR

1. Make floor cut out as shown in Figure 7.
2. Determine the depth of the floor cavity from the surface of the floor to the top of the supply air duct and select the appropriate duct connector from the chart. See Figures 6 and 8.
3. Place locating bracket (supplied with the duct connector) to the back edge of the floor opening. See Figure 9.
4. Apply a water based duct sealant to the 1/2" supply duct attachment flange of the duct connector.
5. Determine which of the four positions the duct connector best centers over the supply duct and insert it through the floor cut-out.
6. When properly aligned with the supply duct, secure the duct connector to the floor with nails, flat head screws or staples.
7. Use screws as required to secure the duct connector to the supply duct.
8. Cut out the opening to the supply duct. If sealant was not used, the installer should tape the mating flanges to provide a good air seal.

NOTE: Duct sealant and tape must be classified as meeting HUD Standard 3280.715, U.L. Standard 181A.

If tape is used to provide a better air seal, it should be a type approved by the applicable national or local codes.

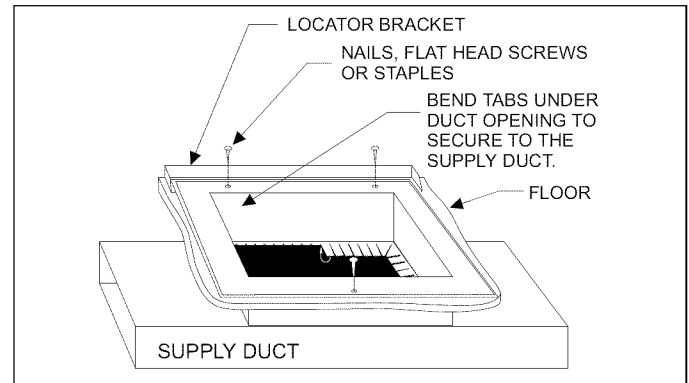

FIGURE 10: Duct Connector Tab Attachment

INSTALLATION OF TAB ATTACHMENT DUCT CONNECTORS

1. Make floor cut out as shown in Figure 7.
2. Determine the depth of the floor cavity from the surface of the floor to the top of the supply air duct and select the appropriate duct connector from the chart. See Figures 6 and 8.
3. Place locating bracket (supplied with the duct connector) to the rear of the floor area for the furnace. See Figure 10.
4. Determine which of the four positions the duct connector best centers over the supply duct and insert it through the floor cut-out.
5. Mark cut-out location on the supply duct and remove the duct connector.
6. Cut out the opening to the supply duct.
7. Bend tabs down through and back up under the supply duct.
8. Secure the duct connector to the floor with nails, flat head screws or staples.

The duct connector is designed for use on ducts down to 12" in width. When using the connector on smaller width ducts, there will not be sufficient clearance to bend the tabs on two sides of the duct connector.

In such cases the tabs may be attached to the sides of the duct by using sheet metal screws or other suitable fasteners. Holes for sheet metal screws are provided in three (3) tabs on each side of the duct connector. If more than 3 tabs need to be used to provide a more secure and air tight connection, the remaining tabs can also be fastened to the duct with screws after drilling the required screw hole.

Furnace and Air Conditioner Installations

If an air conditioner is installed which does not use the blower for air distribution and operates completely independent of the furnace, the thermostat system must have an interlock to prevent the furnace and air conditioner from operating at the same time. This interlock system usually contains a heat-cool switch which must be turned to either HEAT or COOL to activate either heating or cooling operation, or a positive OFF switch on the cooling thermostat.

When used in connection with a cooling unit the furnace shall be installed parallel with or on the upstream side of the cooling unit to avoid condensation in the heat exchanger.

For installations with a parallel flow arrangement, the furnace must be equipped with a damper to prevent cold air from being discharged up around the heat exchanger. Cold air causes condensation inside the exchanger and can cause it to rust out which can allow products of combustion to be circulated into the living area by the furnace blower resulting in possible asphyxiation. An air flow activated automatic damper, P/N 7900-6771, is available from furnace manufacturer. See Figure 11.

NOTE: See label on coil panel for conversion and lighting instructions. Obtain a temperature rise within the ranges specified on the name plate.

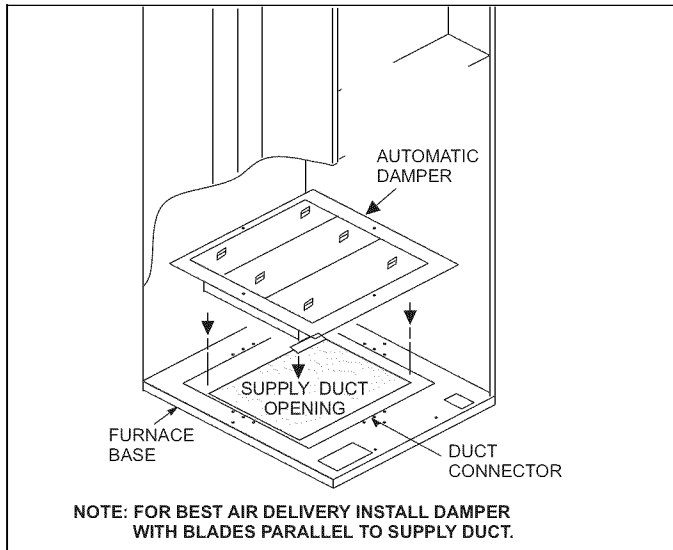

FIGURE 11: Anti-Backflow Damper

INSTALLATION RECOMMENDATIONS

1. Remove the front panels and set the furnace onto the duct connector. Slide it back until the rear of the unit engages the locator bracket.
2. Secure the front of the furnace with two screws at the mounting holes provided.
3. Secure the top of the furnace to a structural member using screw through the strap at the back of the furnace. Strap may be moved to any of the holes located along the top back of the furnace. Installer may provide an equivalent method, such as screws through the casing side.

The duct system is a very important part of the installation. If the duct system is improperly sized the furnace will not operate properly. The ducts attached to the furnace plenum, should be of sufficient size so that the furnace operates at the specified external static pressure and within the air temperature rise specified on the nameplate.

Consideration should be given to the heating capacity required and also to the air quantity (CFM) required. These factors can be determined by calculating the heat loss and heat gain of the home or structure. If these calculations are not performed and the furnace is over-sized, the following may result:

1. Short cycling of the furnace.
2. Wide temperature fluctuations from the thermostat setting.
3. Reduced overall operating efficiency of the furnace.

The supply and return duct system must be of adequate size and designed such that the furnace will operate within the designed air temperature rise range and not exceed the maximum designed static pressure. These values are listed in Table 2.

SECTION III: RETURN AIR REQUIREMENTS

CLOSET INSTALLATIONS

Additional Requirements

Additional requirements for floor and ceiling return system for closet installed sealed combustion heating appliance are given in the next paragraph.

WARNING

HAZARD OF ASPHYXIATION, DO NOT COVER OR RESTRICT FLOOR OPENING.

TABLE 2: External Static Pressure Range

Input		Output		Nominal Air Flow ¹		Ext. Static Pressure			
						Minimum		Maximum	
MBH	kW	MBH	kW	CFM	cmm	In.W.C	kPa	In.W.C	kPa
56	16.4	45	12.9	1305	36.9	0.10	0.0249	0.30	0.0747
70	20.5	56	16.4	1305	36.9	0.10	0.0249	0.30	0.0747
77	22.5	62	18.0	1305	36.9	0.10	0.0249	0.30	0.0747
90	26.3	72	21.1	1305	36.9	0.10	0.0249	0.30	0.0747

1. Std. Blower-High Speed-No Coil.

IMPORTANT

The air temperature rise should be taken only after the furnace has been operating for at least 15 minutes. Temperatures should be taken 6" (15.2 cm) past the first bend from the furnace in the supply duct. The return air temperature must be taken at the return air louvered door. Return static pressures can be taken by pushing probe through the air filter on the louvered door.

BLEND AIR INSTALLATIONS

If a blend air ventilation system is installed, the 5" (12.7 cm) diameter knockout in the top cover must be removed. The blend air damper is to be placed on the top cover and secured with screws as shown in Figure 12. The power wires for the Blend Air Damper are inserted through the 7/8" (2.22 cm) hole in the top cover. The wires to the Blend Air Damper will be connected as shown in Figure 20. Refer to the Blend Air Installation Manual to complete the installation.

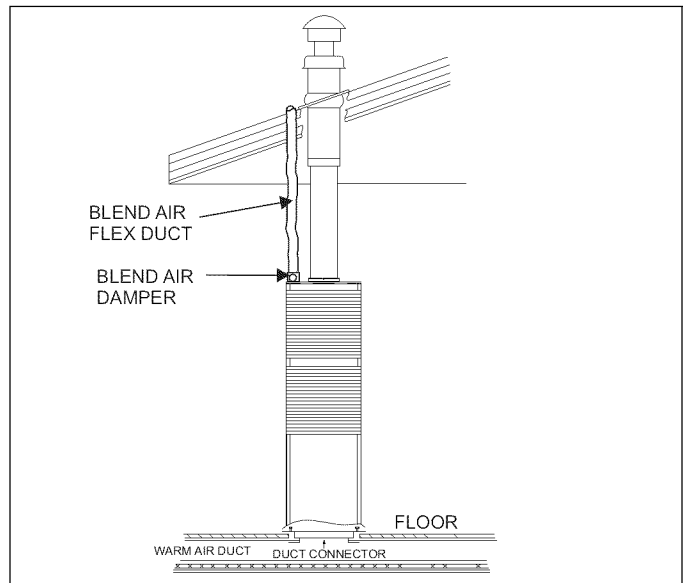

FIGURE 12: Floor Installation

SECTION IV: FILTERS

FILTER INSTALLATION

All applications require the use of a filter. A standard air filter is located in the return filter rack on the louvered door. The air filter(s) must be replaced with air filter(s) that are the same size and same type. Replacement filter size is shown in Table 3.

CAUTION

All installations must have a filter installed.

Downflow Filters:

There are two types of downflow filter racks.

1. **FURNACE FILTER RACK:** A return filter rack with two standard throwaway type filters are supplied on all models. The return filter rack is located on the inside of the louvered door. This type of filter rack is designed for two standard air filters only. Pleated Media or Washable Filters cannot be used in this filter rack because they cause too much pressure drop causing a reduction in airflow. Refer to Figure 13.
2. **EXTERNAL RETURN FILTER GRILLE:** The second type is an external return air filter grille that **can only be used in applications where the furnace is installed in a closet**. This type of filter grille is typically installed in a closet door or wall with the filters located within 12" (30.5 cm) of the return air opening of the furnace. There must be a minimum clearance of 6" (15.2 cm) between the front of the furnace and the closet door and/or the furnace and the filter grille to prevent the return air flow from being obstructed. Refer to Table 1 Unit Clearances to Combustibles.

NOTE: Remove air filters inside louvered door when using an external filter grille.

- a. If the standard throwaway filter are used the external filter grille must have a minimum area of 540 in² (3483 cm²) which would equal a 15" X 36" filter grille.
- b. If the Pleated Media or Washable Filters are used the external filter grille must have a minimum area of 684 in² (4413 cm²) which would equal a 18" X 38" filter grille. The increased area is to reduce the pressure drop across the air filter.
- c. Consideration should be given when locating the return filter grille for maintenance.
- d. Any filter that has a large pressure drop should be checked to be sure the pressure drop caused by the air filter will not prevent the furnace from operating within the rise range, specified on the rating plate and in Table 7. If the furnace does not operate within the specified rise range then a larger air filter or an air filter that has a lower pressure drop must be installed.

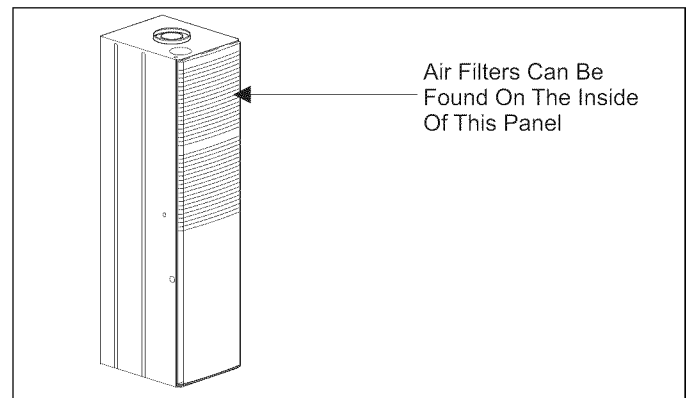

FIGURE 13: Furnace Air Filters

TABLE 3: Filter Sizes - All Models

Input		Output		Air Flow		Cabinet Width	Door Filter ¹	
MBH	kW	MBH	kW	CFM	cmm	In	In	cm
56	16.4	44.8	13.1	1305	34.0	19 3/4	2 - 16 x 20 x 1	2 x 41 x 51
70	20.5	56	16.4	1305	34.0	19 3/4	2 - 16 x 20 x 1	2 x 41 x 51
77	22.5	62	18.1	1305	34.0	19 3/4	2 - 16 x 20 x 1	2 x 41 x 51
90	26.3	72	21.1	1305	34.0	19 3/4	2 - 16 x 20 x 1	2 x 41 x 51

1. All Models shipped with disposable filters mounted inside upper furnace door.
2. Pleated filters have high pressure drop and require cleaning every 60 days.
3. Dirty filters can cause excess heating bills, lower air flow, and reduce heat exchanger life.

SECTION V: GAS LINE INSTALLATION

GAS SAFETY

DANGER

This furnace is designed to operate on NATURAL GAS or PROPANE GAS ONLY. Do Not Burn any other Fuel in this furnace. Burning any fuel except NATURAL GAS or PROPANE GAS can cause premature heat exchanger burnout, high levels of carbon monoxide, excessive sooting, a fire hazard, personal injury, property damage and /or death.

DANGER

An overpressure protection device, such as a pressure regulator, must be installed in the gas piping system upstream of the furnace and must act to limit the downstream pressure to the gas valve so it does not exceed 0.5 PSI (14" w.c. (3.48 kPa). Pressures exceeding 0.5 PSI (14" w.c. (3.48 kPa) at the gas valve will cause damage to the gas valve, resulting in a fire or explosion or cause damage to the furnace or some of its components that will result in property damage and loss of life.

GAS PIPING

Installation and Checking of Gas Line

Gas Supply piping must be sized in accordance with the recommendations contained in National Fuel Gas Code (ANSI-Z223.1, NFPA-54) unless local codes or regulations state otherwise.

Materials used and pipe sizing for U.S. manufactured homes must comply with requirements contained in Manufactured Homes A119.1, Recreational Vehicles A119.2 and H.U.D. Title 24, Section 3280.705 and any local or state codes.

NOTE: The gas line inlet on the gas valve is 1/2-14 N.P.T. The gas line may be installed through the furnace floor or furnace side to the gas valve.

CAUTION

If the gas input to the furnace is too great because of excessive gas pressure, wrong size orifice, high altitude, etc., the burner flame will be sooty and may produce carbon monoxide, which could result in unsafe operation, explosion, and/or fire or asphyxiation.

CAUTION

To install gas line and to connect it to the gas valve, care must be taken to hold gas valve firmly to prevent misalignment of the burner orifice, or to damage gas valve which could result in improper heating, explosion, fire or asphyxiation.

DO NOT USE EXCESSIVE PIPE SEALANT ON PIPE JOINTS. Pipe sealant, metal chips or other foreign material that could be deposited in the inlet of the gas valve, when gas pipe is installed or carried through the gas piping into the gas valve inlet after installation, may cause the gas valve to malfunction and could result in possible improper heating, explosion, fire or asphyxiation. Also, pipe sealant must be resistant to Propane gas.

Where regulations require, a main shut-off valve shall be installed externally of furnace casing. After piping has been installed, turn gas on and check all connections with a leak detector or soap solution.

Never use open flame to test for gas leaks as fire or explosion could occur.

Do not test the fuel system at more than 14" W.C. after furnace has been connected to fuel line. Such testing could void the warranty. Any test run above 14" W.C. may damage furnace control valve which could cause an explosion, fire or asphyxiation.

A drip leg is recommended in the gas supply line to trap moisture and contaminations. Refer to Figure 14.

For natural gas operation, the furnace is designed for 7" W.C. inlet gas pressure. Pressure to main burner is then reduced to 3 1/2" W.C.

GAS PIPING INSTALLATION

Properly sized wrought iron, approved flexible or steel pipe must be used when making gas connections to the unit. If local codes allow the use of a flexible gas appliance connection, always use a new listed connector. Do not use a connector that has previously serviced another gas appliance.

Some utility companies or local codes require pipe sizes larger than the minimum sizes listed in these instructions and in the codes. The furnace rating plate and the instructions in this section specify the type of gas approved for this furnace - only use those approved gases.

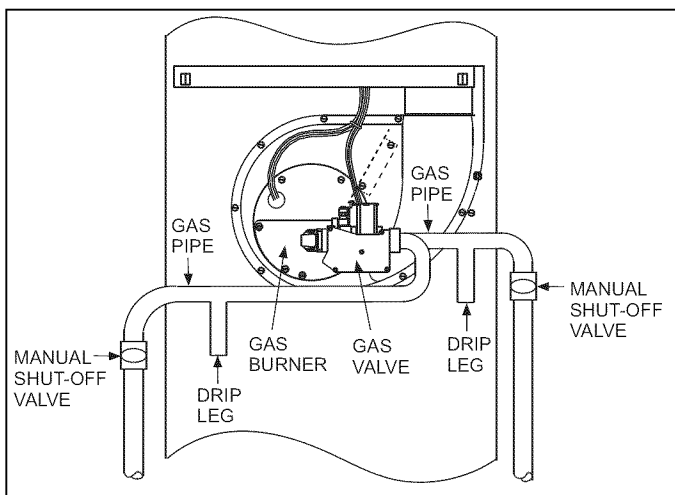

FIGURE 14: Gas Piping

IMPORTANT

An accessible manual shut-off valve must be installed upstream of the furnace gas controls and within 6 feet (1.8 m) of the furnace.

The furnace must be isolated from the gas supply piping system by closing its individual external manual shut-off valve during any pressure testing of the gas supply piping system at pressures equal to or less than 1/2 psig (3.5 kPa).

CAUTION

The gas valve body is a very thin casting that cannot take any external pressure. Never apply a pipe wrench to the body of the gas valve when installing piping. A wrench must be placed on the square hub located on the gas inlet side of the valve. Placing a wrench to the body of the gas valve will damage the valve causing improper operation and/or the valve to leak.

Gas piping may be connected from either side of the furnace using any of the gas pipe entry knockouts on both sides of the furnace. Refer to Figure 14 Gas Piping.

GAS ORIFICE CONVERSION FOR PROPANE (LP)

WARNING

This conversion shall be installed by a qualified service agency in accordance with the manufacturer's instructions and all applicable codes and requirements of the authority having jurisdiction. If the information in these instructions is not followed exactly, a fire, an explosion or production of carbon monoxide may result causing property damage, personal injury or loss of life. The qualified service agency is responsible for the proper installation. The installation is not proper and complete until the operation of the converted appliance is checked as specified in the manufacturer's instructions.

WARNING

Improper installation may damage equipment, can create a shock hazard, and will void the warranty.

IMPORTANT

These instructions are for the use of qualified individuals specially trained, experienced and certified in the installation of this type of equipment and related systems components. Installation and service personnel are required by some states to be licensed. Persons not qualified shall not install this equipment nor interpret these instructions.

NOTE: The words "Shall" or "Must" indicate a requirement, which is essential to satisfactory and safe product performance.

NOTE: The words "Should" or "May" indicate a recommendation or advice which is not essential and not required but which may be useful or helpful.

CONTENTS

1. Burner orifices for LP (propane) gas are located in bag attached to the gas valve. Size is marked on orifice.
2. Conversion plate.

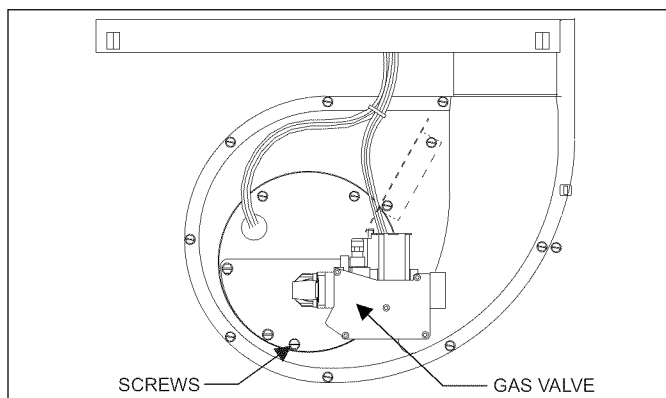

FIGURE 15: Burner Assembly

CONVERSION PROCEDURE**⚠ CAUTION**

The gas supply must be shut off prior to disconnecting the electrical power, before proceeding with the conversion.

⚠ WARNING

SHOCK HAZARD - Turn off electrical supply to furnace.

1. Shut off gas supply at valve upstream from furnace or at meter as required. Refer to Figure 14.
2. Disconnect gas supply piping from gas valve on furnace.
3. Disconnect electrical wires from gas valve, noting which wires are connected to which terminals.
4. Remove 4 bolts that attach the gas valve to the 90° flange.

⚠ CAUTION

The rubber "O" ring provided seals the gas valve to the 90° flange. Make sure it is installed when the gas valve is attached to that flange.

5. Remove the four screws that attach the gas manifold to the burner support box. See Figure 15.
6. Remove and discard natural gas orifices.
7. Remove LP (propane) orifices from the bag attached to the gas valve.
8. Install the LP (propane) gas orifices supplied with the furnace. Tighten to 15 - 25 inch - pounds of torque.
9. Reinstall the manifold in the assembly by reversing the removal process.
10. Reconnect the wires to the proper terminals on the gas valve.
11. Remove the regulator with the blue cap and turn it upside down so the letters "LF" are upright. Place the blue cap on the opposite end of the regulator.
12. Convert the gas valve for LP (propane) gas operation by following the instructions. Remove the natural tag and replace with the propane tag supplied in the orifice bag.
13. Remove the blue conversion label on the furnace door after the furnace has been converted.
14. Reconnect the gas supply piping to the gas valve and insure that all gas connections are tight.
15. Remove pressure tap plugs from gas valve and connect water gauge to the pressure tap ports. See Figure 30 for location of the gas valve pressure taps and pressure regulator adjustment.
16. Turn on gas supply to furnace and check all gas connections with suitable leak detector.

⚠ WARNING

Never use an open flame to check for leaks. Fire or explosion could occur. Since some leak solutions including soap and water may cause corrosion or stress cracking, the piping must be rinsed with water after testing unless it has been determined that the leak test solution is non-corrosive.

IMPORTANT

When converting gas valve from or to Propane gas, it will be necessary to change main burner orifice to prevent an underfired or overfired condition. See label inside lower furnace door for complete instructions.

HIGH ALTITUDE GAS ORIFICE CONVERSION

This furnace is constructed at the factory for natural gas-fired operation at 0 – 2,000 ft. (0 m – 610 m) above sea level.

The gas orifices on this furnace must be changed in order to maintain proper and safe operation, when the furnace is installed in a location where the altitude is greater than 2,000 ft. (610 m) above sea level on natural gas or the altitude is greater than 4,000 ft. (1219 m) above sea level on propane (LP) gas. Refer to Table 6 or the instructions in the high altitude conversion kit for the proper gas orifice size.

For Propane gas operation, the furnace is designed for 11" W.C. inlet gas pressure. Pressure to main burner is then reduced to 10" W.C.

The unit may also be converted for altitudes up to 10,000 ft. (3048 m) on natural and propane (LP) gas with additional derate as shown in Table 6 or refer to ANSI Z223.1 NFPA 54 National Fuel Gas Code or in Canada CAN/CGA-B149.1-00 Natural Gas and Propane Installation Code.

⚠ DANGER**PROPANE AND HIGH ALTITUDE CONVERSION KITS**

It is very important to choose the correct kit and/or gas orifices for the altitude and the type of gas for which the furnace is being installed.

Only use natural gas in furnaces designed for natural gas. Only use propane (LP) gas for furnaces that have been properly converted to use propane (LP) gas. Do not use this furnace with butane gas.

Incorrect gas orifices or a furnace that has been improperly converted will create an extremely dangerous condition resulting in premature heat exchanger failure, excessive sooting, high levels of carbon monoxide, personal injury, property damage, a fire hazard and/or death.

High altitude and propane (LP) conversions are required in order for the appliance to satisfactory meet the application.

An authorized distributor or dealer must make all gas conversions.

In Canada, a certified conversion station or other qualified agency, using factory specified and/or approved parts, must perform the conversion.

The installer must take every precaution to insure that the furnace has been converted to the proper gas orifice size when the furnace is installed. Do not attempt to drill out any orifices to obtain the proper orifice size. Drilling out a gas orifice will cause misalignment of the burner flames, causing premature heat exchanger burnout, high levels of carbon monoxide, excessive sooting, a fire hazard, personal injury, property damage and/or death.

TABLE 4: High Altitude Duration Chart

NATURAL GAS													
Elevation Feet	56,000 — Input				70,000 — Input			77,000 — Input			90,000 — Input		
	Meters	Orifice Dia.	Drill Size	Part #	Orifice Dia.	Drill Size	Part #	Orifice Dia.	Drill Size	Part #	Orifice Dia.	Drill Size	Part #
Sea Level		0.136	29	9951-1361	0.154	23	9951-1541	0.161	20	9951-1611	0.180	15	9951-1801
2,000	618	0.136	29	9951-1361	0.149	25	9951-1491	0.157	22	9951-1571	0.177	16	9951-1771
3,000	914	0.128	30	9951-1281	0.149	25	9951-1491	0.157	22	9951-1571	0.173	17	9951-1731
4,000	1219	0.128	30	9951-1281	0.147	26	9951-1471	0.154	23	9951-1541	0.173	17	9951-1731
5,000	1524	0.128	30	9951-1281	0.144	27	9951-1441	0.152	24	9951-1521	0.169	18	9951-1691
6,000	1829	0.128	30	9951-1281	0.144	27	9951-1441	0.149	25	9951-1491	0.166	19	9951-1661
7,000	2134	0.120	31	9951-1201	0.140	28	9951-1401	0.147	26	9951-1471	0.161	20	9951-1611
8,000	2438	0.120	31	9951-1201	0.136	29	9951-1361	0.144	27	9951-1441	0.161	20	9951-1611
9,000	2743	0.120	31	9951-1201	0.136	29	9951-1361	0.140	28	9951-1401	0.157	22	9951-1571
10,000	3048	0.116	32	9951-1161	0.128	30	9951-1281	0.136	29	9951-1361	0.152	24	9951-1521

PROPANE GAS													
Elevation Feet	56,000 — Input				70,000 — Input			77,000 — Input			90,000 — Input		
	Meters	Orifice Dia.	Drill Size	Part #	Orifice Dia.	Drill Size	Part #	Orifice Dia.	Drill Size	Part #	Orifice Dia.	Drill Size	Part #
Sea Level		0.082	45	9951-0821	0.093	42	9951-0931	0.098	40	9951-0981	0.106	36	9951-1061
2,000	618	0.081	46	9951-0811	0.093	42	9951-0931	0.096	41	9951-0961	0.104	37	9951-1041
3,000	914	0.078	47	9951-0781	0.089	43	9951-0891	0.093	42	9951-0931	0.101	38	9951-1011
4,000	1219	0.078	47	9951-0781	0.089	43	9951-0891	0.093	42	9951-0931	0.101	38	9951-1011
5,000	1524	0.078	47	9951-0781	0.089	43	9951-0891	0.093	42	9951-0931	0.099	39	9951-0991
6,000	1829	0.076	48	9951-0761	0.086	44	9951-0861	0.089	43	9951-0891	0.098	40	9951-0981
7,000	2134	0.076	48	9951-0761	0.086	44	9951-0861	0.089	43	9951-0891	0.096	41	9951-0961
8,000	2438	0.073	49	9951-0731	0.082	45	9951-0821	0.086	44	9951-0861	0.096	41	9951-0961
9,000	2743	0.073	49	9951-0731	0.081	46	9951-0811	0.086	44	9951-0861	0.093	42	9951-0931
10,000	3048	0.070	50	9951-0700	0.078	47	9951-0781	0.082	45	9951-0821	0.089	43	9951-0891

Table shows 4% Input Reduction per 1,000 feet Elevation. Reference Source: NFPA No. 54, ANSI Z 223.1, National Fuel Gas Code. For Canadian installation, no orifice or manifold pressure reduction is required for 0-4, 500ft.

SECTION VI: ELECTRICAL POWER

Electrical Power Connections

Field wiring to the unit must be grounded. Electric wires that are field installed shall conform to the temperature limitation for 63°F (35°C) rise wire when installed in accordance with instructions. Refer to Table 5 in these instructions for specific furnace electrical data.

CAUTION

Use copper conductors only.

SUPPLY VOLTAGE CONNECTIONS

1. Provide a power supply separate from all other circuits. Install overcurrent protection and disconnect switch per local/national electrical codes. The switch should be close to the unit for convenience in servicing. With the disconnect or fused switch in the OFF position, check all wiring against the unit wiring label. Refer to the wiring diagram in this instruction.
2. Remove the screws retaining the wiring box cover. Route the power wiring through the opening in the unit into the junction box with a conduit connector or other proper connection. In the junction box there will be three wires, a Black Wire, a White Wire and a Green Wire. Connect the power supply as shown on the unit-wiring label on the inside of the blower compartment door or the wiring schematic in this section. The black furnace lead must be connected to the L1 (hot) wire from the power supply. The white furnace lead must be connected to neutral. Connect the green furnace lead (equipment ground) to the power supply ground.

3. The furnace's control system requires correct polarity of the power supply and a proper ground connection. Refer to Figure 16.

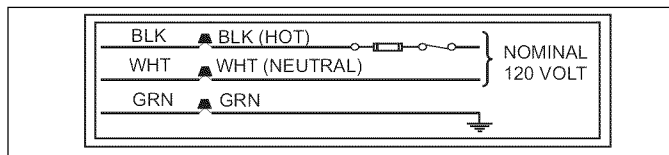

FIGURE 16: Line Wiring Connections

LOW VOLTAGE CONTROL WIRING CONNECTIONS

1. Insert 24 volt wires through the small plastic bushing just above the control panel.
2. Connect the thermostat wires to the furnace low voltage pigtails. See Figure 17 (heating only) and Figure 18 or 19 (heating and cooling).
3. Connect thermostat wires to the furnace when installing blend air accessory as shown in Figure 20.
4. Connect low-voltage circuit to the wall thermostat pigtails.

NOTE: Five-conductor thermostat cable is recommended for all installations to allow easy installation of an air conditioning system at a later time.

IMPORTANT

Set the heat anticipator in the room thermostat to 0.40 amps. Setting it lower will cause short cycles. Setting it higher will cause room temperature to exceed the set points.

Eighteen gauge thermostat wire is highly recommended.

Smaller gauge thermostat wire may be used only if the guideline below is followed.

Thermostat Wire Length (Furnace to Thermostat)	Thermostat Wire Gauge
0 - 45 feet	22
0 - 70 feet	20

Do not use the thermostat wire smaller than 22 gauge. If thermostat wire small than 18 gauge is used, pay particular attention that the connections between the different wire sizes are tight.

Operational problems may be caused by loose connections or by the use of thermostat wire that is too small to carry the required load. Any such problems are the responsibility of the installer.

A separate 115 V.A.C. supply circuit must be used for the furnace. The circuit should be protected by a 15 amp fuse or circuit breaker.

Avoid locations where the thermostat could be subject to drafts from outside, or exposed to direct light from lamps, sun, fireplaces, etc., or affected by air from a duct register blowing directly on the thermostat.

The wall thermostat should be located 52 to 66 inches above the floor. The preferred location is on an inside wall situated in an area with good air circulation, and where the temperature will be reasonably representative of other living areas the thermostat is controlling.

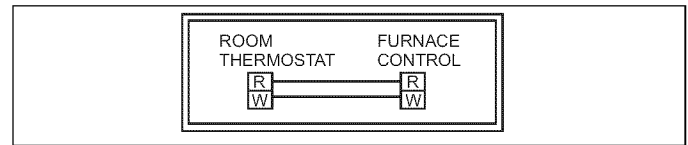

FIGURE 17: Wiring for Heat Only Thermostat

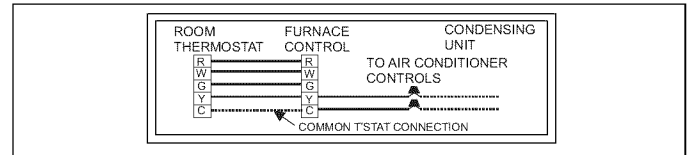

FIGURE 18: Wiring for Electronic Heat-Cool Thermostat

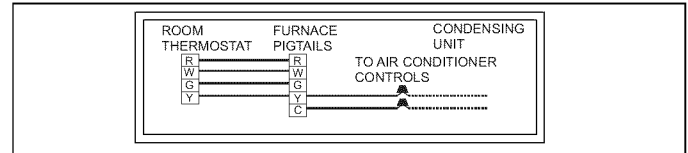

FIGURE 19: Wiring for Standard Heat-Cool Thermostat

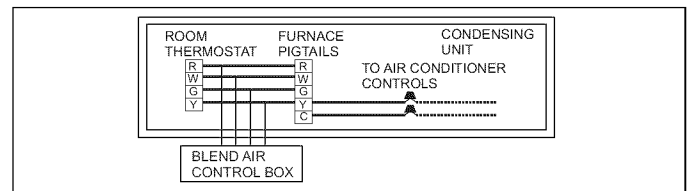

FIGURE 20: Wiring for Blend Air Accessory

TABLE 5: Ratings & Physical / Electrical Data

Input		Output		Nominal ¹ CFM(m ³ /min)		Cabinet Width		AFUE	Air Temp. Rise		Operation Wgt.	
MBH	kW	MBH	kW	CFM	cmm	In.	cm		°F	°C	LBS	Kg
DGAA SERIES												
56	16	45	13	1305	37	19-1/2	49.5	80.0	45 - 75	25 - 41.7	163	73.9
70	21	56	16	1305	37	19-1/2	49.5	80.0	45 - 75	25 - 41.7	163	73.9
77	23	62	18	1305	37	19-1/2	49.5	80.0	45 - 75	25 - 41.7	163	73.9
90	26	72	21	1305	37	19-1/2	49.5	80.0	45 - 75	25 - 41.7	163	73.9
DGAH SERIES												
56	16	45	13	1050	30	19-1/2	49.5	80.0	45 - 75	25 - 41.7	146	66.2
77	23	62	18	1050	30	19-1/2	49.5	80.0	45 - 75	25 - 41.7	146	66.2
Input		Max. Outlet Air Temp		Blower		Blower Size		Total Unit	Ignitor	Booster Motor & Gas Valve	Max Over-Current Protect	Min. wire Size (awg) @ 75 ft one way
MBH	kW	°F	°C	Hp	Amps	In.	cm	Amps	Amps	Amps		
DGAA SERIES												
56	16	165	73.9	1/3	7.3	10 x 8	25.4 x 20.3	12.0	4.1	0.6	15	14
70	21	165	73.9	1/3	7.3	10 x 8	25.4 x 20.3	12.0	4.1	0.6	15	14
77	23	165	73.9	1/3	7.3	10 x 8	25.4 x 20.3	12.0	4.1	0.6	15	14
90	26	165	73.9	1/3	7.3	10 x 8	25.4 x 20.3	12.0	4.1	0.6	15	14
DGAH SERIES												
56	16	165	73.9	1/6	7.8	10 x 8	25.4 x 20.3	12.4	4.1	0.6	15	14
77	23	165	73.9	1/6	7.8	10 x 8	25.4 x 20.3	12.4	4.1	0.6	15	14

1. 0.3" Ext. Static Duct Pressure - No Coil - Std. Blower - High Speed

SECTION VII: ROOF JACK VENT/ COMBUSTION AIR SYSTEM VENT AND COMBUSTION AIR SAFETY

This Category I, furnace is designed for Manufactured (Mobile) Home and Modular Home application. It may be installed without modification in a garage, equipment room, alcove or any other indoor location where all required clearance to combustibles and other restrictions are met, AND providing factory Roof Jack System meets all installation requirements.

The venting system must be installed in accordance with Section 5.3, Air for Combustion and Ventilation, of the National Fuel Gas Code Z223.1/ NFPA 54 (latest edition), or Sections 7.2, 7.3 or 7.4 of CAN/CGA B149.1-00, National Gas and Propane Codes (latest edition) or applicable provisions of the local building code and these instructions. The furnace shall not be connected to any chimney, a flue serving a separate appliance, or any appliance designed to burn solid fuel. The furnace rating plate lists the maximum vent gas temperature.

It is recommended that the appliance is installed in a location where the space temperature is 32 °F (0°C) or higher. If the appliance is installed in a location where the ambient temperature is below 32 °F (0°C), the combustion by-products could condense causing damage to the appliance heat exchanger and/or the Roof Jack.

IMPORTANT

The "VENT SYSTEM" must be installed as specified in these instructions for Manufactured (Mobile) Home and Modular Homes. This appliance must be vented with an approved roof jack may not be common vented with another gas appliance.

Modular Homes must be vented with an approved roof jack and may not be common vented with other appliances.

WARNING

Failure to follow all venting instructions can result in fire, asphyxiation, or explosion.

CAUTION

Only use the appropriate roof jack. See Figures 21 and 22 for correct application.

Do not exceed the maximum height as determined from Figures 21 and 22. Installer should allow an additional 1-1/2" travel before the flue pipe assembly is fully extended against the built-in stop. This provides an additional safeguard against the flue assembly being pulled from the roof jack during transportation or other stress conditions.

EXISTING FURNACE REPLACEMENT

If this furnace replaces an existing furnace, do the following:

1. If a 2nd roof, roof cap or addition has been made to the existing roof of the home, remove the old roof jack completely! To avoid the possibility of an improperly installed pipe or gaps in the old roof jack, INSTALL A NEW ROOF JACK. Your ceiling and roof height will determine the correct roof jack to use. Refer to the vent selection table, of the furnace installation instructions.
2. After unpacking the roof jack, check the rain caps. Insure they are not damaged, tilted or crooked. Do not twist, crush or sit on the roof caps during installation. Damaged roof caps will cause improper furnace operation. The furnace will not heat properly and could result in explosion.
3. Before inserting the roof jack into the furnace top, inspect the furnace flue and combustion air opening for debris or insulation which might have fallen in during pre-installation steps. Do not proceed unless all debris has been cleaned out or removed.
4. After installing roof jack on furnace top collar, check to make sure there is no gap in back or side between the pipe collar and the furnace casing top.
5. Use only the pipes provided with the roof jack assembly. Do not add to or adapt other sheet metal pipes. Do not cut, insert or add other pipes to this assembly.
6. In no case should there be a gap between sections of the flue pipe or the combustion air pipe.

NEW HOME INSTALLATION

If this furnace is installed in a new home do the following:

1. Inspect the furnace top collars for signs of insulation or ceiling debris which might have fallen in during cutting of the ceiling and roof holes. Remove all debris before continuing.
2. After unpacking the roof jack, check the rain caps. Insure they are not damaged, tilted or crooked. Do not twist, crush or sit on the roof caps during installation. Damaged roof caps will cause improper furnace operation. The furnace will not heat properly and could result in explosion.

3. Before inserting the vent pipe into the furnace top, inspect the furnace flue and combustion air opening for debris or insulation which have fallen in during pre-installation steps. Do not proceed unless all debris have been cleaned out or removed.
4. After installing roof jack on furnace top collar, check to make sure there is no gap in back or side between the pipe collar and the furnace casing top.

INSTALLATION IN SNOW REGIONS

When the combustion air pipe inlet is covered or blocked with snow, the furnace will not operate properly due to the depleted combustion air supply.

Therefore, if the furnace will be located in regions where snow accumulation on the roof exceeds 4" or in H.U.D. Snow Load Zones, a roof jack extension (Part No. 7680B6541) is recommended.

LOCATING AND CUTTING ROOF JACK OPENING

To facilitate the proper installation of the roof jack, it is very important that the roof jack opening in the ceiling and roof be on the same vertical center line as the furnace flue collar. See Figure 21 or 22.

Mark this location on ceiling and scribe a circle with a 5" radius (10" diameter) around this mark. Cut opening for roof jack through ceiling and roof. (If furnace was installed during construction, cover furnace and flue opening to prevent debris from entering flue when hole is cut for roof jack.)

INSTALLING ROOF JACK IN THE ROOF

(See Figures 21 and 22 for Dimensional requirements.)

Insert roof jack into opening in the roof.

The roof jack should be secured to the furnace before roof flange (flashing) is secured to the roof. This will insure a better alignment of the flue pipe and furnace flue collar. Caulk around and under roof flange to provide a water tight seal, before securing roof jack flashing to roof.

1. Provide protection for Vent Connector and Air-Intake Connector from damage and debris.
2. Mark Roof Jack center line on ceiling. Cut a 5" radius (10" diameter) hole through ceiling.
3. Mark Roof Jack center line on roof. Cut oblong hole through roof.
4. Insert Roof Jack through roof opening. Do not secure Roof Jack to roof.

Connect Roof Jack to Furnace

1. Verify gasket is around outside of Air-Intake Connector. Install new gasket if missing or damaged.
2. Pull the Roof Jack's telescoping section down onto furnace. Fully engage Roof Jack onto Vent Connector and Air-Intake Connector and compress gasket. See Figure 24. Refer to Interior Roof Jack Extension installation instructions, if applicable.
3. Align holes in Roof Jack and Air-Intake Connector. Secure Roof Jack to furnace using #10 x 1/2 - 1-1/2" Type AB or Type B sheet metal screw.

Secure Roof Jack to Roof

1. Apply caulk or other sealant to underside of Roof Jack flashing.
2. Locate Roof Jack such that pipes are plumb.
3. Secure Roof Jack flashing with nails, screws or staples.
4. Install roofing material over Roof Jack flashing.
5. Seal Roof Jack swivel joint with Chemcaulk 900 Sealant. Not required for Roof Jacks with fixed slant flashing.

Complete Installation, as required

1. Install Exterior Roof Jack Extension, if applicable. Refer to installation instructions provided with Exterior Roof Jack Extension. Refer to Figure 23.

SWIVEL FLASHING ADJUSTS FROM 0/12 TO 5/12 PITCH	SLANT FLASHING 3/12 PITCH	DGAH FURNACES	DGAA FURNACES
		INSTALLATION DIMENSIONS	INSTALLATION DIMENSIONS
		"A" ADJUSTABLE HEIGHT	"B" ADJUSTABLE HEIGHT
4000-7101/C	4000-6101/A	70" to 79"	86" to 95"
4000-7121/C	4000-6121/A	75" to 86"	91" to 102"
4000-7141/C	4000-6141/A	83" to 104"	99" to 120"
4000-7151/C	4000-6151/A	90" to 116"	106" to 132"
4000-7171/C	4000-6171/A	127" to 157"	143" to 173"

¹ The 4084-7141 is dimensionally the same as 4000-7141/C and is available only in Canada.

² The 4084-7151 is dimensionally the same as 4000-7151/C and is available only in Canada.

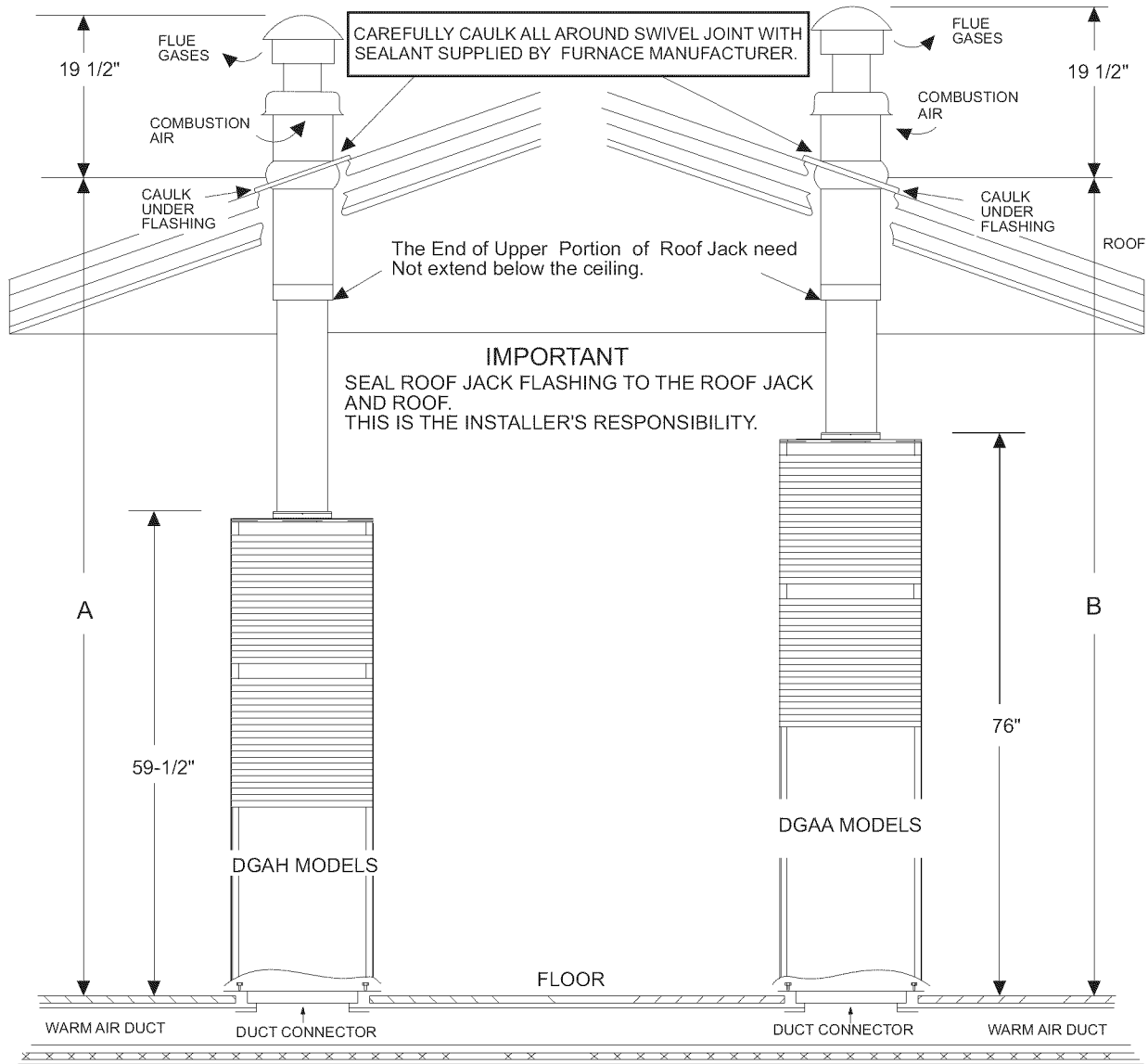

FIGURE 21: Standard Roof Jack

SWIVEL FLASHING ADJUSTS FROM 0/12 TO 5/12 PITCH	SLANT FLASHING 3/12 PITCH	DGAH FURNACES	DGAA FURNACES
		INSTALLATION DIMENSIONS	INSTALLATION DIMENSIONS
		"A" ADJUSTABLE HEIGHT	"B" ADJUSTABLE HEIGHT
4000-8161/C	4000-9161/A	85" to 101"	101" to 117"
4000-8181/C	4000-9181/A	99" to 129"	115" to 145"

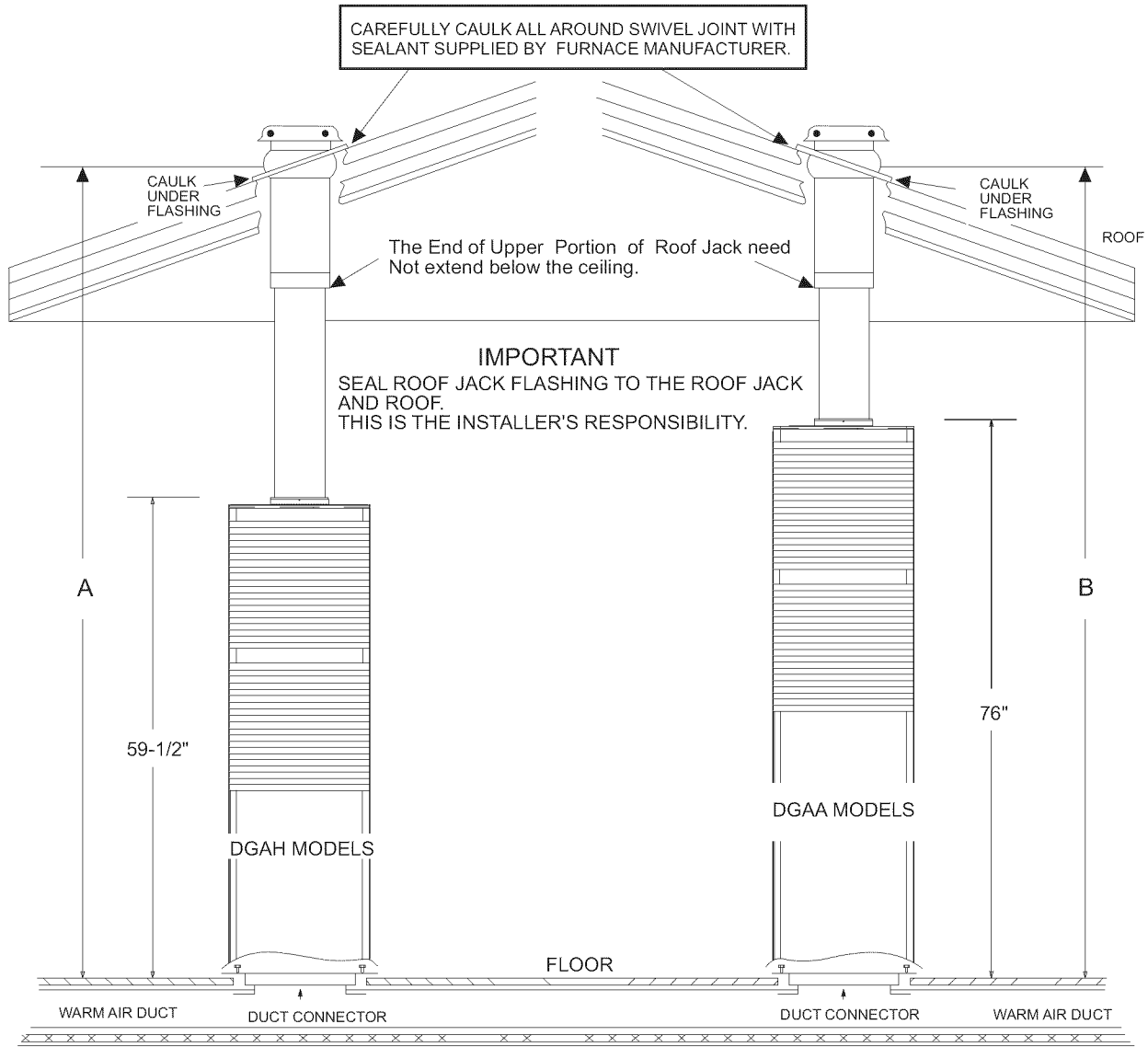

FIGURE 22: Roof Jack With Removable Crowns

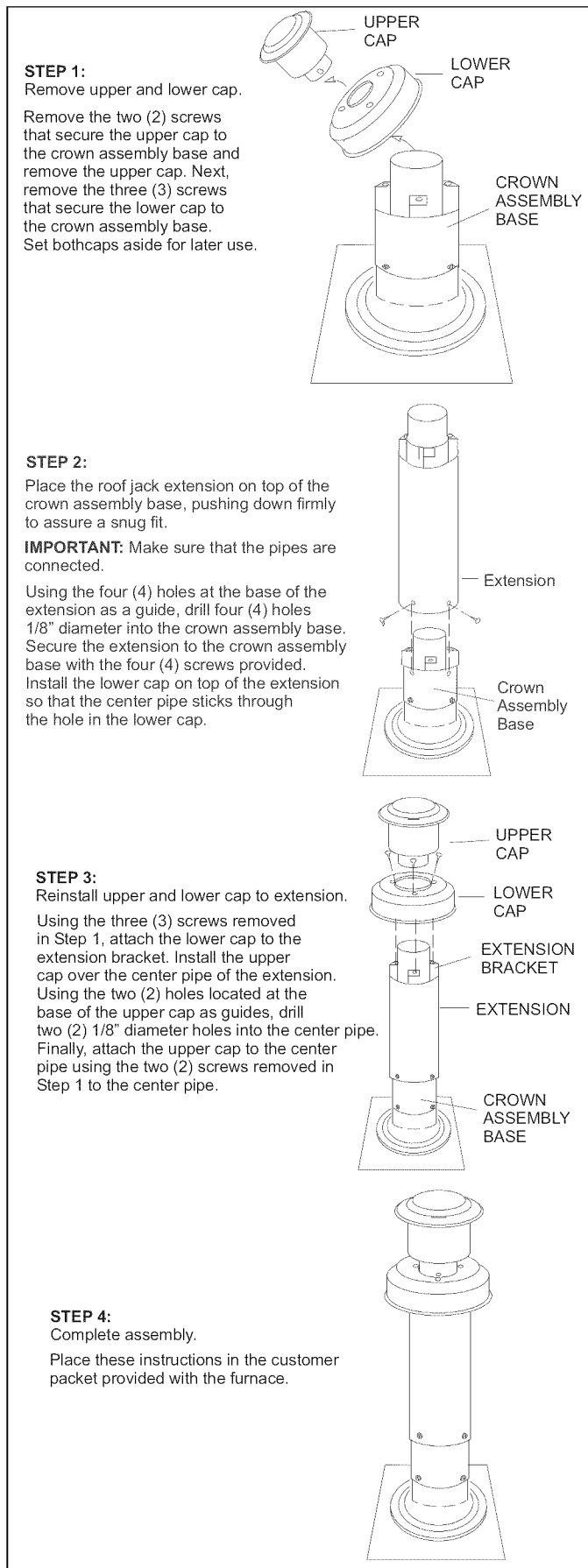

FIGURE 23: Roof Jack

EXTERIOR ROOF JACK EXTENSION

Available to comply with instances in which the roof jack crown needs to be raised to meet a roof clearance requirement. One extension will raise the roof jack crown by 18 inches.

CONNECTING ROOF JACK TO FURNACE

CAUTION

The inner flue pipe must be present.

It is mandatory that the combustion air pipe and flue pipe assembly be fully engaged. The combustion air pipe MUST be securely fastened to the furnace with a sheet metal screw in the hole provided.

Use a 1/2" blunt or sharp end sheet metal screw to fasten roof jack combustion air pipe to furnace combustion air collar. Screw hole is provided in the pipe and collar. Excessively long screws may extend to flue pipe and puncture it. Screws are not to exceed 1 1/2" in length.

NOTE: Combustion air tube and flue pipe are part of the same assembly. Only the combustion air tube need be fastened to the furnace.

1. Check to be certain that the flue pipe and combustion air tube are present.
2. Pull the telescoping flue tube and combustion air tube assembly down from the roof jack. Slide the flue tube/combustion air tube assembly down firmly over the furnace flue outlet and combustion air collar. Insure that the back, side and front of combustion air tube collar is fully engaged and is in contact with gasket. Fasten the combustion air tube to the furnace combustion air collar using a 1/2 inch sheet metal screw. (Screw hole provided in combustion air tube and furnace combustion air collar. See Figure 24).

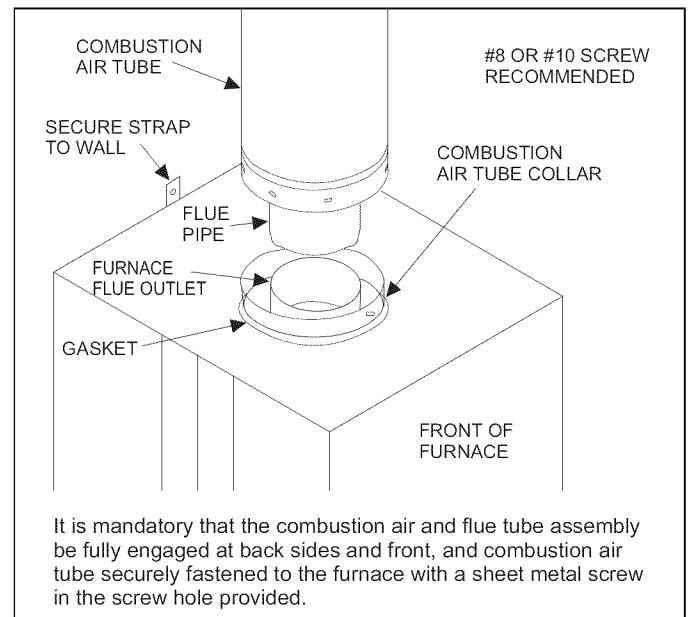

FIGURE 24: Connecting Roof Jack to Furnace

COMBUSTION AND VENTILATION AIR

This furnace is a sealed combustion (direct vent) unit and is design certified to use only a 4000 Series roof jack. These roof jacks are designed to provide combustion air to the furnace and to exhaust flue products to the outside. No other combustion air openings or ducts are needed.

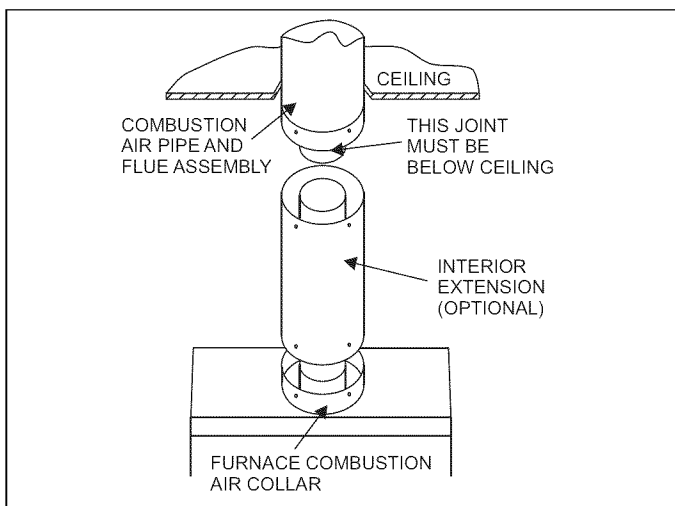

FIGURE 25: Roof Jack Assembly

INTERIOR EXTENSIONS

To choose the proper length roof jack with or without the optional extension see Figure 25 and Table 8. More than one interior extension may be used to accommodate A "dimensions up to 110" (284.5 cm).

WARNING

The joint where the optional interior extension connects to the roof jack must be below the ceiling. Failure to observe this requirement may result in asphyxiation, fire, or explosion

NOTE: Use of an interior extension will increase the roof jack adjustable heights by the amount of the interior extension height. If the furnace is installed on an elevated plenum, the plenum height must be added to the roof jack height.

CAUTION

Do not exceed the maximum adjustable height as listed in Table 6. These maximum heights allow an additional 1 1/2" (3.81 cm) travel before the flue pipe assembly is fully extended against the built-in stop. This provides an additional safeguard against the flue assembly being pulled from the roof jack if upward movement should occur when the home is being transported or subjected to other stress conditions. Failure to follow these instructions may result in fire, explosion, or asphyxiation.

TABLE 6: Roof Jack Options

Roof Jack Model Number	Adjustable Height with no Interior Extension	Adjustable Height with on 17" Interior Extension
4000B7141	14" to 78"	64" to 95"
4000B7151	66" to 90"	83" to 107"
4000B8161	59" to 79"	76" to 96"
4000B8181	73" to 103"	90" to 110"

Models 4000B8161 and 4000B8181 have removable crowns.

CAUTION

Use 1/2" (1.27 cm) blunt or sharp end sheet metal screws to fasten roof jack combustion air pipe to furnace combustion air collar. Screw holes are provided in pipe and collar. Excessively long screws may extend to flue pipe and puncture it. If substitute screws are used, they must not exceed 1 1/2" (3.81 cm) in length. It is mandatory that the combustion air and flue tube assembly be properly engaged, and the combustion air pipe fastened to the furnace with sheet metal screws in the holes provided.

If using an optional interior extension, place extension down on furnace top and mate with furnace flue and combustion air collar until it lines up with screw holes in combustion air collar. Secure the extension to the furnace using the pre-punched holes. Use 1/2" (1.27 cm) blunt or sharp end sheet metal screws to fasten roof jack combustion air pipe to furnace combustion air collar. Screw holes are provided in pipe and collar. Excessively long screws may extend to flue pipe and puncture it. If substitute screws are used, they must not exceed 1 1/2" (3.81 cm) in length. Pull the roof jack flue and combustion air pipe assembly down and mate with extension flue and combustion air pipes until the screw holes line up. See Figure 25. Fasten interior extension to combustion air pipe assembly with sheet metal screws not exceeding 1 1/2" (3.81 cm) in length.

IMPORTANT

Under no circumstances shall the connection between the flue and combustion air pipe assembly of the roof jack and the interior extension be above the ceiling line.

Secure the roof jack to the roof with screws. Non-hardening mastic sealer or caulking compound must be used to seal the roof flange to prevent water leakage. The roof jack swivel joint must also be sealed to prevent water leakage.

INSTALLING CEILING RING

The ceiling ring is to meet fire stop requirements. Accessory Ceiling Ring may be used (See Figure 26) or the mobile home or modular home manufacturer or the installer may use other approved methods to fire stop. If required, three sections of the Accessory ring may be used as in Figure 26 to provide closer clearance around the roof jack.

NOTE: A portion of the outer edge of the ceiling ring may be trimmed so the ring will fit between the warm air plenum and roof jack.

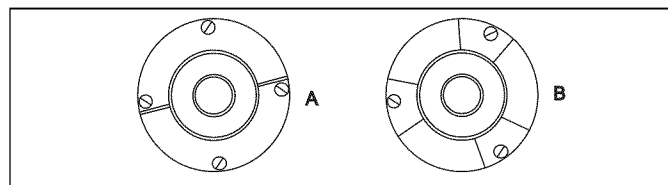

FIGURE 26: Ceiling Rings

VENT CLEARANCES

IMPORTANT

The vent must be installed with the minimum clearances as shown in Figure 27, and must comply with local, state, regional codes and requirements.

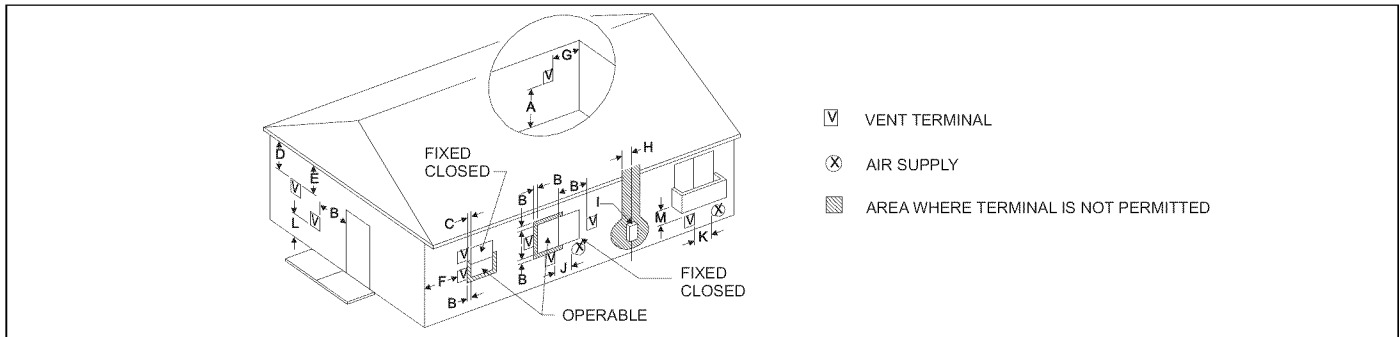

FIGURE 27: Home Layout

	Canadian Installations ¹	US Installation ²
A. Clearance above grade, veranda, porch, deck, or balcony	12 inches (30 cm)	12 inches (30 cm)
B. Clearance to window or door that may be opened	12 inches (30 cm) for models <100,000 BTUH (30 kW), 36 inches (91 cm) for models > 100,000 BTUH (30 kW)	4 Feet
C. Clearance to permanently closed window	4 Feet	4 Feet
D. Vertical clearance to ventilated soffit located above the terminal within a horizontal distance of 2 feet (61 cm) from the center line of the terminal	4 Feet	4 Feet
E. Clearance to unventilated soffit	12 Inches	12 Inches
F. Clearance to outside corner	12 Inches	12 Inches
G. Clearance to inside corner	6 Feet	6 Feet
H. Clearance to each side of center line extended above meter/regulator assembly	3 feet (91 cm) within a height 15 feet (4.5 m) above the meter/regulator assembly	3 feet (91 cm) within a height 15 feet (4.5 m) above the meter/regulator assembly
I. Clearance to service regulator vent outlet	3 feet (91 cm)	3 feet (91 cm)
J. Clearance to nonmechanical air supply inlet to building or the combustion air inlet to any other appliance	12 inches (30 cm) for models <100,000 BTUH (30 kW), 35 inches (91 cm) for models >100,000 BTUH (30 kW)	4 Feet
K. Clearance to a mechanical supply inlet	6 feet (1.83 m)	3 feet (91 cm) above if within 10 feet (3 cm) horizontally
L. Clearance above paved sidewalk or paved driveway located on public property	7 feet (2.13 m) †	7 feet (2.13 m) †
M. Clearance under veranda, porch, deck, or balcony	12 inches (30.4 cm)	12 inches (30.4 cm)
Vent Termination from any Building Surface	12" (30.4 cm)	12" (30.4 cm)
Above anticipated snow depth	12" (30.4 cm)	12" (30.4 cm)

1. In accordance with the current CSA B149.1-00, Natural Gas and Propane Installation Code.

2. In accordance with the current ANSI Z223.1 / NFPA 54, National Gas Code. In accordance with the current UL 311 Standard for Safety for Roof Jacks for Manufactured Homes and Recreational Vehicles.

† A vent shall not terminate directly above a sidewalk or paved driveway that is located between two single family dwellings and serves both dwellings.

‡ Permitted only if veranda, porch, deck, or balcony is fully open on a minimum of two sides beneath the floor. For clearance not specified in ANSI Z223.1 / NFPA 54 or CSA B149.1-00.

** Clearance in accordance with local installation codes and the requirements of the gas supplier and the manufacturer's Installation Manual.

Any fresh air or make up inlet for dryer or furnace area is considered to be forced air inlet.

Avoid areas where condensate drippage may cause problems such as above planters, patios, or adjacent to windows where steam may cause fogging.

A terminus of a vent shall be either:

Fitted with a cap in accordance with the vent manufacturer's installation instructions, or In accordance with the installation instructions for a special venting system.

Responsibility for the provision of proper adequate venting and air supply for application shall rest with the installer.

Vent shall extend high enough above building, or a neighboring obstruction, so that wind from any direction will not create a positive pressure in the vicinity of the vent.

IMPORTANT

Consideration must be given for degradation of building materials by flue gases. Sidewall termination may require sealing or shielding of building surfaces with a corrosion resistant material to protect against combustion product corrosion. Consideration must be given to wind direction in order to prevent flue products and/or condensate from being blown against the building surfaces. If a metal shield is used it must be a stainless steel material at a minimum dimension of 20 inches. It is recommended that a retaining type collar be used that is attached to the building surface to prevent movement of the vent pipe.

WARNING**CARBON MONOXIDE POISONING HAZARD**

Failure to follow the steps outlined below for each appliance connected to the venting system being placed into operation could result in carbon monoxide poisoning or death.

The following steps shall be followed for each appliance connected to the venting system being placed into operation, while all other appliances connected to the venting system are not in operation:

1. Inspect the venting system for proper size and horizontal pitch. Determine that there is no blockage, restriction, leakage, corrosion or other deficiencies, which could cause an unsafe condition
2. Close all building doors and windows and all doors.
3. Turn on clothes dryers and TURN ON any exhaust fans, such as range hoods and bathroom exhausts, so they shall operate at maximum speed. Open the fireplace dampers. Do not operate a summer exhaust fan.
4. Follow the lighting instructions. Place the appliance being inspected in operation. Adjust thermostat so the appliance shall operate continuously.
5. Test each appliance (such as a water heater) equipped with a draft hood for spillage (down-draft or no draft) at the draft hood relief opening after 5 minutes of main burner operation. Appliances that do not have draft hoods need to be checked at the vent pipe as close to the appliance as possible. Use a combustion analyzer to check the CO₂ and CO levels of each appliance. Use a draft gauge to check for a downdraft or inadequate draft condition.
6. After it has been determined that each appliance properly vents when tested as outlined above, return doors, windows, exhaust fans, fireplace dampers and any other gas burning appliance to their normal condition.
7. If improper venting is observed during any of the above tests, a problem exists with either the venting system or the appliance does not have enough combustion air (Supply Air from outside) to complete combustion. This condition must be corrected before the appliance can function safely.

NOTE: An unsafe condition exists when the CO reading at the furnace vent exceeds 40 ppm and the draft reading is not in excess of - 0.1 in. W.C. (-25 kPa) with all of the appliance(s) operating at the same time.

8. Any corrections to the venting system and / or to the supply (outside) air system must be in accordance with the National Fuel Gas Code Z223.1 or CAN/CGA B149.1-00 Natural Gas and Propane Installation Code (latest editions). If the vent system must be resized, follow the appropriate tables in Appendix G of the above codes or for this appliance.

FAN-ASSISTED COMBUSTION SYSTEM

An appliance equipped with an integral mechanical means to either draw or force products of combustion through the combustion chamber and/or heat exchanger.

SECTION VIII: SAFETY CONTROLS**CONTROL CIRCUIT FUSE**

A 3-amp fuse is provided on the control circuit board to protect the 24-volt transformer from overload caused by control circuit wiring errors. This is an ATO 3, automotive type fuse and is located on the control board.

PRESSURE SWITCHES

This furnace is supplied with a pressure switch, which monitors the flow through the combustion air/vent piping system. This switch de-energizes the ignition control module and the gas valve if any of the following conditions are present. Refer to Figure 28 for tubing connections.

1. Blockage of combustion air piping or terminal.
2. Blockage of vent piping or terminal.
3. Failure of combustion air blower motor.

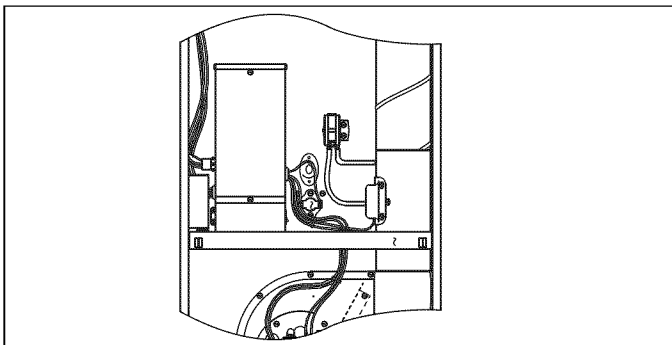

FIGURE 28: Pressure Switch Tubing Routing

LIMIT CONTROLS

There is high temperature limit control located on the furnace vestibule panel near the gas valve. This is an automatic reset control that provides over temperature protection due to reduced airflow, that may be caused by a dirty filter, or if the indoor fan motor should fail. The control module will lockout if the limit trips 3 consecutive times. Control will reset and try ignition again after 1 hour.

SECTION IX: START-UP AND ADJUSTMENTS

The initial start-up of the furnace requires the following additional procedures:

IMPORTANT

All electrical connections made in the field and in the factory should be checked for proper tightness.

When the gas supply is initially connected to the furnace, the gas piping may be full of air. In order to purge this air, it is recommended that the ground union be loosened until the odor of gas is detected. When gas is detected, immediately retighten the union and check for leaks. Allow five minutes for any gas to dissipate before continuing with the start-up procedure. Be sure proper ventilation is available to dilute and carry away any vented gas.

TOOLS AND INFORMATION THAT WILL BE REQUIRED IN ORDER TO PROPERLY PERFORM THE FURNACE START-UP PROCEDURE.

1. Call the local gas supplier to obtain heating value of the natural gas. If you cannot obtain the heating value of the gas from the gas supplier, you may use a default value of 1030 BTU/SCF (38.8 MJ / m³).
2. You will need a thermometer or portable digital thermometer to read the supply and return air temperatures.
3. You will need a U-tube manometer or digital equipment that has the ability to read pressures between 0 – 15" in.w.c (0 - 3.73 kPa) in order to measure the gas line and the manifold pressures.
4. You will need a 3/32" Allen wrench for the pressure port plugs in the gas valve.
5. You will need 2 pieces of 1/8" (0.3 cm) ID flexible tubing that is 12" (30 cm) in length, 2 – pieces of 1/8" (0.3 cm) tubing that are 4" (10.0 cm) in length, and a 1/8" (0.3 cm) adapter to connect the U-tube manometer or the digital pressure measuring equipment to the gas valve pressure ports.

There is an accessory kit (1PK0601) available from Source 1, which has the following items:

- 1 - 12" (30 cm) length x 1/8" (0.3 cm) diameter tubing
- 2 – pieces of 4" (10 cm) length x 1/8" (0.3 cm) diameter tubing
- 1 - 5/16" (0.8 cm) tee
- 1 – 5/16" (0.8 cm) x 1/8" (0.3 cm) reducing coupling
- 1 – 1/8" (0.3 cm) adapter

There is a accessory kit (1PK0602) available from Source 1, which has the following items:

- 12" (30 cm) length x 1/8" (0.3 cm) diameter tubing
- 2 – pieces of 4" (10 cm) length x 1/8" (0.3 cm) diameter tubing
- 1 - 5/16" (0.8 cm) tee
- 1 – 5/16" (0.8 cm) x 1/8" (0.3 cm) reducing coupling
- 1 – 1/8" (0.3 cm) adapter
- 1 - Dwyer – Manometer

These items are required in order to properly perform the required start-up procedure.

IGNITION SYSTEM SEQUENCE

1. Turn the gas supply ON at external valve and main gas valve.
2. Set the thermostat above room temperature to call for heat.
3. System start-up will occur as follows:
 - a. The induced draft blower motor will start and come up to speed. Shortly after inducer start-up, the hot surface igniter will glow for about 30 seconds.
 - b. After this warm up, the ignition module will energize (open) the main gas valve.
 - c. After flame is established, the supply air blower will start in the time set on the control board.

WARNING

FIRE OR EXPLOSION HAZARD

Failure to follow the safety warnings exactly could result in serious injury, death or property damage.

Never test for gas leaks with an open flame. Use a commercially available soap solution made specifically for the detection of leaks to check all connections. A fire or explosion may result causing property damage, personal injury or loss of life.

IMPORTANT

Burner ignition may not be satisfactory on first start-up due to residual air in the gas line or until gas manifold pressure is adjusted. The ignition control will make 3 attempts to light before locking out.

With furnace in operation, check all of the pipe joints, gas valve connections and manual valve connections for leakage using an approved gas detector, a non-corrosive leak detection fluid, or other leak detection methods. Take appropriate steps to stop any leak. If a leak persists, replace the component.

The furnace and its equipment shut-off valve must be disconnected from the gas supply piping system during any pressure testing of that system at test pressures in excess of 1/2 PSI (3.45 kPa).

The furnace must be isolated from the gas supply piping system by closing the equipment shut-off valve during any pressure testing of the gas supply piping system.

CALCULATING THE FURNACE INPUT (NATURAL GAS)

NOTE: Burner orifices are sized to provide proper input rate using natural gas with a heating value of 1030 BTU/Ft³. If the heating value of your gas is significantly different, it may be necessary to replace the orifices.

1. Turn off all other gas appliances connected to the gas meter.
2. At the gas meter, measure the time (with a stop watch) it takes to use 2 cubic ft. (0.0566 m³) of gas.
3. Calculate the furnace input by using one of the following equations.

In the USA use the following formula to calculate the furnace input.

For natural gas multiply the heat content of the gas BTU/SCF or Default 1030 BTU/SCF (38.4 MJ/m³), times 2 cubic ft. (0.056 m³) of gas measured at the gas meter, times a barometric pressure and temperature correction factor of 0.960; times 3600, then divided by the time (In seconds) it took to measure 2 cubic ft. (0.056 m) of gas from the gas meter.

For propane (LP) gas multiply the heat content of the gas BTU/SCF or Default 2500 BTU/SCF (93.15 MJ/m³), times 1 cubic ft. (0.028 m³) of gas measured at the gas meter, times a barometric pressure and temperature correction factor of 0.960; times 3600, then divided by the time (In seconds) it took to measure 1 cubic ft. (0.028 m) of gas from the gas meter.

The formula for US input calculation using a cubic foot gas meter:

$\frac{\text{BTU/ft}^3 \times 2 \text{ cu.ft.} \times 0.960 \times 3600}{\text{Seconds it took to measure the 2 cu.ft. of gas}}$	=	BTU/H	$\frac{\text{BTU/ft}^3 \times 1 \text{ cu.ft.} \times 0.960 \times 3600}{\text{Seconds it took to measure the 1 cu.ft. of gas}}$	=	BTU/H
NATURAL GAS INPUT CALCULATION			PROPANE (LP) GAS INPUT CALCULATION		
EXAMPLE:			EXAMPLE:		
$\frac{1030 \times 2 \times 0.960 \times 3600}{90.5}$	=	78,666.90	$\frac{2500 \times 1 \times 0.960 \times 3600}{108}$	=	80,000.00
Natural Gas			Propane Gas		
1030 BTU/SCF			2500 BTU/SCF		

In Canada you will use the following formula to calculate the furnace input if you are using a cubic foot gas meter.

For Natural Gas multiply the Heat content of the gas MJ/m³ (or Default 38.4), times 2 cubic ft. of gas x 0.028 to convert from cubic feet to cubic meters measured at the gas meter, times a barometric pressure and temperature correction factor of 0.960; times 3600, then divided by the time it took to measure 2 cubic ft. (0.056 m) of gas from the gas meter.

For Propane (LP) Gas multiply the Heat content of the gas MJ/m³ (or Default 93.15), times 1 cu. ft. of gas x 0.028 to convert from cubic feet to cubic meters measured at the gas meter, times a barometric pressure and temperature correction factor of 0.960; times 3600, then divided by the time it took to measure 1 cubic ft. (0.028 m) of gas from the gas meter.

The formula for metric input calculation using a cubic foot gas meter:

$\frac{\text{MJ/m}^3 \times 2 \text{ cu.ft.} \times 0.028 \times 0.960 \times 3600}{\text{Seconds it took to measure the 2 cu.ft. of gas}}$	=	MJ/H	x	0.2777	=	kW	x	3412.14	=	BTU/H
NATURAL GAS INPUT CALCULATION										
EXAMPLE:										
$\frac{38.4 \times 2 \times 0.028 \times 0.960 \times 3600}{90.5}$	=	82.12	x	0.2777	=	22.80	x	3412.14	=	77,796.80
Natural Gas										
1030 BTU/SCF = 38.4 MJ/m ³										
PROPANE (LP) GAS INPUT CALCULATION										
EXAMPLE:										
$\frac{93.15 \times 1 \times 0.028 \times 0.960 \times 3600}{108}$	=	83.46	x	0.2777	=	23.18	x	3412.14	=	79,093.4
Propane Gas										
2500 BTU/SCF = 93.15 MJ/m ³										

In Canada use the following formula to calculate the furnace input if you are using a gas meter that measures cubic meters.

For Natural Gas multiply the Heat content of the gas MJ/m³ (or Default 38.4), times 0.10 m³ of gas measured at the gas meter, times a barometric pressure and temperature correction factor of 0.960; times 3600, then divided by the time it took to measure 0.10 m³ of gas from the gas meter.

For Propane (LP) Gas multiply the Heat content of the gas MJ/m³ (or Default 93.15), times 0.10 m³ of gas measured at the gas meter, times a barometric pressure and temperature correction factor of 0.960; times 3600, then divided by the time it took to measure 0.10 m³ of gas from the gas meter.

The formula for metric input calculation using a cubic meter gas meter:

$\frac{\text{MJ/m}^3 \times \text{m}^3 \times 0.960 \times 3600}{\text{Seconds it took to measure the 0.10 m}^3 \text{ of gas}}$	=	MJ/H	x	0.2777	=	kW	x	3412.14	=	BTU/H
NATURAL GAS INPUT CALCULATION										
EXAMPLE:										
$\frac{38.4 \times 0.1 \times 0.960 \times 3600}{160}$	=	82.94	x	0.2777	=	23.03	x	3412.14	=	78,581.60
Natural Gas										
1030 BTU/SCF = 38.4 MJ/m ³										
PROPANE (LP) GAS INPUT CALCULATION										
EXAMPLE:										
$\frac{93.15 \times 0.1 \times 0.960 \times 3600}{387}$	=	83.19	x	0.2777	=	23.10	x	3412.14	=	78,826.3
Propane Gas										
2500 BTU/SCF = 93.15 MJ/m ³										

DO NOT ADJUST the manifold pressure regulator if the actual input is equal to or within 8% less than the furnace input specified on the rating plate or if the furnace rise is above the specified rise range on the rating plate.

If the actual input is significantly higher than the furnace input specified on the rating plate then replace the gas orifices with the gas orifices of the proper size for the type of gas you are using.

For altitudes above 2,000 ft. (610 m) the furnace input MUST BE DERATED. Refer to the GAS CONVERSION FOR PROPANE (LP) AND HIGH ALTITUDES IN SECTION IV for information on high altitude conversions.

⚠ CAUTION

Be sure to relight any gas appliances that were turned off at the start of this input check.

CHECKING THE GAS PRESSURES

1. The pressure ports on the gas valve are marked OUT PRESSURE TAP and INLET PRESSURE TAP.
2. The manifold pressure must be taken at the port marked OUT P.
3. The inlet gas supply pressure must be taken at the port marked IN P.
4. Using a 3/32" (0.2 cm) Allen wrench, loosen the set screw by turning it 1 turn counter clockwise. **DO NOT REMOVE THE SET SCREW FROM THE PRESSURE PORT.**
5. Push one end of the 3/8" (0.9 cm) ID flexible tubing over the pressure port so that the body of the port is inside the tubing.
6. Use a reducer connector to connect the 3/8" (0.9 cm) ID flexible tube that is connected to a "U" tube manometer or digital pressure measuring equipment.

TABLE 7: Inlet Gas Pressure Range

INLET GAS PRESSURE RANGE		
	Natural Gas	Propane (LP)
Minimum	4.5" W.C. (1.12 kPa)	8.0" W.C. (1.99 kPa)
Maximum	10.5" W.C. (2.61 kPa)	13.0" (3.24 kPa) W.C.

IMPORTANT

The inlet gas pressure operating range table specifies the minimum and maximum gas line pressures required for safe furnace operation.

The minimum inlet gas pressure required to obtain the BTU input specified on the rating plate and in these instructions is shown below:

- 4.5" W.C. (1.12 kPa) for Natural Gas
- 11.0" W.C. (2.74 kPa) for Propane (LP) Gas

ADJUSTMENT OF MANIFOLD GAS PRESSURE

Manifold gas pressure may be measured at the gas valve.

Turn gas off at the ball valve or gas cock on gas supply line before the gas valve. Find the pressure ports on the gas valve marked OUT P and IN P.

1. The manifold pressure must be taken at the port marked OUT P.
2. The gas line pressure must be taken at the port marked IN P.
3. Using a 3/32" Allen wrench, loosen the set screw by turning it 1 turn counter clockwise. **DO NOT REMOVE THE SET SCREW FROM THE PRESSURE PORT.**

Use the 4" (10.2 cm) piece of 1/8" (0.3 cm) tubing to connect the positive side of the manometer to the gas valve pressure reference port. Refer to Figure 30 for connection details.

IMPORTANT

The cap for the pressure regulator must be removed entirely to gain access to the adjustment screw. Loosening or tightening the cap does not adjust the flow of gas.

1. Refer to Figure 29 for location of pressure regulator adjustment cap and adjustment screw on main gas valve.
2. Turn gas and electrical supplies on and follow the operating instructions to place the unit back in operation.
3. Adjust manifold pressure by adjusting gas valve regulator screw for the appropriate gas per the following:

TABLE 8: Nominal Manifold Pressure

NOMINAL MANIFOLD PRESSURE	
Natural Gas	3.5" w.c. (0.87 kPa)
Propane (LP) Gas	10.0" w.c. (2.488 kPa)

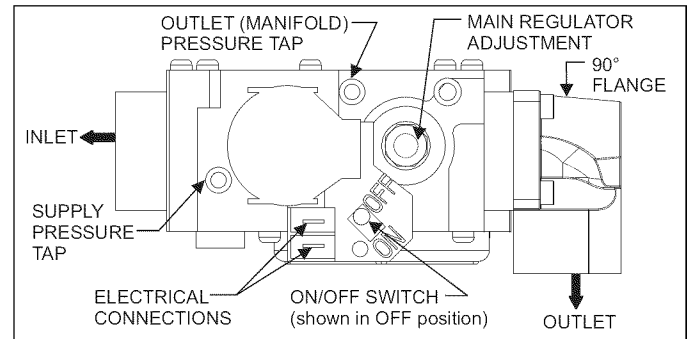

FIGURE 29: Gas Valve

IMPORTANT

If gas valve regulator is turned in (clockwise), manifold pressure is increased. If screw is turned out (counter clockwise), manifold pressure will decrease.

4. After the manifold pressure has been adjusted, re-calculate the furnace input to make sure you have not exceeded the specified input on the rating plate. Refer to "CALCULATING THE FURNACE INPUT (NATURAL GAS)".
5. Once the correct BTU (kW) input has been established, turn the gas valve to OFF and turn the electrical supply switch to OFF; then remove the flexible tubing and fittings from the gas valve pressure tap and tighten the pressure tap plug using the 3/32" Allen wrench.
6. Turn the electrical and gas supplies back on, and with the burners in operation, check for gas leakage around the gas valve pressure port for leakage using an approved gas detector, a non-corrosive leak detection fluid, or other leak detection methods.

⚠ WARNING

The manifold pressure must be checked with the screw-off cap for the gas valve pressure regulator in place. If not, the manifold pressure setting could result in an over-fire condition. A high manifold pressure will cause an over-fire condition, which could cause premature heat exchanger failure. If the manifold pressure is too low, sooting and eventual clogging of the heat exchanger could occur. Be sure that gas valve regulator cap is in place and burner box to gas valve pressure reference hose is connected.

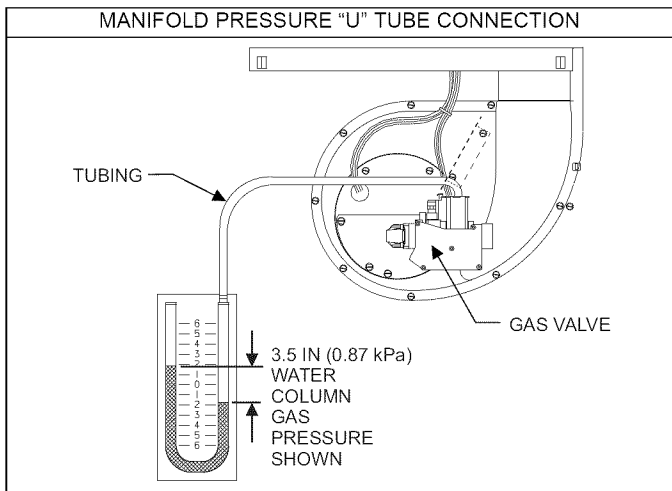

FIGURE 30: Reading Gas Pressure

ADJUSTMENT OF TEMPERATURE RISE

⚠ DANGER

The temperature rise, or temperature difference between the return air and the supply (heated) air from the furnace, must be within the range shown on the furnace rating plate and within the application limitations shown in Table 7 "ELECTRICAL AND PERFORMANCE DATA".

The supply air temperature cannot exceed the "Maximum Supply Air Temperature" specified in these instructions and on the furnace rating plate. Under NO circumstances can the furnace be allowed to operate above the Maximum Supply Air Temperature. Operating the furnace above the Maximum Supply Air Temperature will cause premature heat exchanger failure, high levels of Carbon Monoxide, a fire hazard, personal injury, property damage, and/or death.

The temperature rise, or temperature difference between the return air and the heated supply air from the furnace, must be within the range shown on the furnace rating plate and within the application limitations as shown in Table 7.

After about 20 minutes of operation, determine the furnace temperature rise. Take readings of both the return air and the heated air in the ducts.

⚠ CAUTION

Do not energize more than one motor speed at a time or damage to the motor will result.

ADJUSTMENT OF FAN CONTROL SETTINGS

This furnace is equipped with a time-on/time-off heating fan control. The fan off delay has 4 settings (60, 90, 120 and 180 seconds). The fan off delay is factory set to 120 seconds. The fan-off setting must be long enough to adequately cool the furnace, but not so long that cold air is blown into the heated space. The fan-off timing may be adjusted by positioning the jumper on two of the four pins as shown in Figure 31.

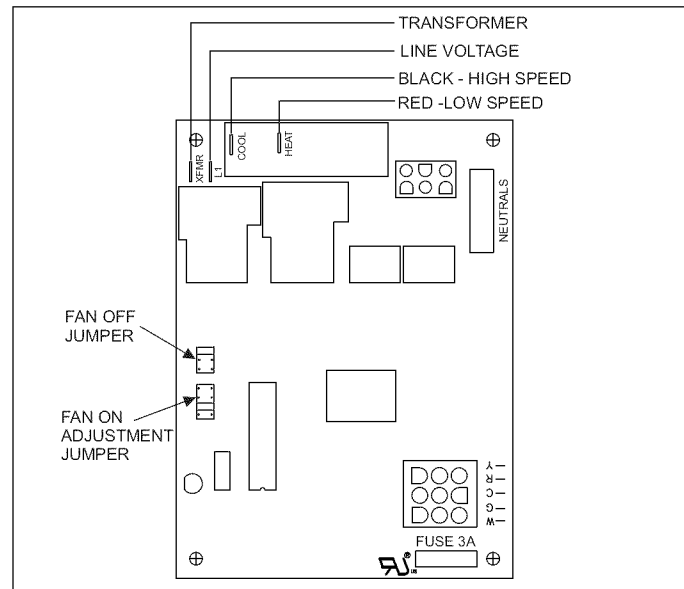

FIGURE 31: Furnace Control Board

FILTER PERFORMANCE

The airflow capacity data published in Table 9 represents blower performance WITHOUT filters.

APPLYING FILTER PRESSURE DROP TO DETERMINE SYSTEM AIRFLOW

Example: For a 90,000 BTUH (26.4 kW) furnace operating on high-speed blower, it is found that total system static is 0.18" (0.045 kPa) w.c. To determine the system airflow, complete the following steps:

Obtain the airflow values at 0.10 w.c. (0.02 Pa) & 0.20 w.c. (0.05 Pa) ESP.

Airflow @ 0.10": 1425 CFM (40.4 m³/min)

Airflow @ 0.20": 1380 CFM (38.2 m³/min)

Subtract the airflow @ 0.10 w.c. (0.02 Pa) from the airflow @ 0.20 w.c. (0.05 Pa) to obtain airflow difference.

1425 - 1250 = -175 CFM (5.0 m³/min)

Subtract the total system static from 0.10 w.c. (125 Pa) and divide this difference by the difference in ESP values in the table 0.18 w.c. (0.045 kPa) - 0.10 w.c. (125 Pa), to obtain a percentage.

$(0.18 - 0.10) / (0.20 - 0.10) = 0.2$

Multiply percentage by airflow difference to obtain airflow reduction.

$(0.2) \times (175) = -35 \text{ CFM (0.99 m}^3\text{/min)}$

Subtract airflow reduction value to airflow @ 0.10 w.c. (125 Pa) to obtain actual airflow @ 0.18 in. w.c. (0.045 kPa) ESP.

1425 (40.4) - 35 = 1390 (39.4 m³/min)

FINAL PROCEDURE

Install Furnace Doors

Install the lower door first by sliding the bottom of the door down until the tabs on the casing base engage the slots in the bottom door end cap. Then push the top of the lower door in until the door clips snap into place. Install the upper door in a similar manner, first engaging the slots in the top of the upper door on the tabs on the casing top. Then snap the bottom of the upper door into place against the casing.

Finish and Trim

Alcove and Closet Installations may now be finished and trimmed as necessary.

TABLE 9: Blower Performance CFM - Downflow Without Filters

STANDARD HEATING BLOWERS			Speed Tap	EXTERNAL STATIC PRESSURE, INCHES WC (kPa)									
BTU/H (kW) Input / Output	Nominal CFM(m ³ /min)	Cabinet Size		0.1 (0.025)		0.2 (0.050)		0.3 (0.075)		0.4 (0.099)		0.5 (0.124)	
				cfm	cm/m	cfm	cm/m	cfm	cm/m	cfm	cm/m	cfm	cm/m
56/45 (16.4/13.1)	1305 (37)	A	High No Coil	1425	40.4	1380	39.1	1305	37.0	1245	35.3	1180	33.4
			High w/Coil	1385	39.2	1315	37.3	1260	35.7	1200	34.0	1135	32.2
			Low No Coil	1250	35.4	1205	34.1	1145	32.4	1085	30.7	1030	29.2
			Low w/Coil	1235	35.0	1190	33.7	1135	32.2	1080	30.6	1015	28.8
70/56 (20.5/16.4)	1305 (37)	A	High No Coil	1425	40.4	1380	39.1	1305	37.0	1245	35.3	1180	33.4
			High w/Coil	1385	39.2	1315	37.3	1260	35.7	1200	34.0	1135	32.2
			Low No Coil	1250	35.4	1205	34.1	1145	32.4	1085	30.7	1030	29.2
			Low w/Coil	1235	35.0	1190	33.7	1135	32.2	1080	30.6	1015	28.8
77/62 (22.5/18.5)	1305 (37)	A	High No Coil	1425	40.4	1380	39.1	1305	37.0	1245	35.3	1180	33.4
			High w/Coil	1385	39.2	1315	37.3	1260	35.7	1200	34.0	1135	32.2
			Low No Coil	1250	35.4	1205	34.1	1145	32.4	1085	30.7	1030	29.2
			Low w/Coil	1235	35.0	1190	33.7	1135	32.2	1080	30.6	1015	28.8
90/72 (26.3/21.1)	1305 (37)	A	High No Coil	1425	40.4	1380	39.1	1305	37.0	1245	35.3	1180	33.4
			High w/Coil	1385	39.2	1315	37.3	1260	35.7	1200	34.0	1135	32.2
			Low No Coil	1250	35.4	1205	34.1	1145	32.4	1085	30.7	1030	29.2
			Low w/Coil	1235	35.0	1190	33.7	1135	32.2	1080	30.6	1015	28.8
7900 - 7751 AC/ACCESSORY BLOWER			Speed Tap	EXTERNAL STATIC PRESSURE, INCHES WC (kPa)									
BTU/H (kW) Input / Output	Nominal CFM(m ³ /min)	Cabinet Size		0.1 (0.025)		0.2 (0.050)		0.3 (0.075)		0.4 (0.099)		0.5 (0.124)	
				cfm	cm/m	cfm	cm/m	cfm	cm/m	cfm	cm/m	cfm	cm/m
56/45 (16.4/13.1)	1725 (48.9)	A	High w/Coil	1800	51.0	1760	49.9	1725	48.9	1680	47.6	1650	46.7
			Med High w/Coil	1535	43.5	1505	42.6	1480	41.9	1445	40.9	1410	39.9
			Med Low w/Coil	1270	36.0	1240	35.1	1215	34.4	1185	33.6	1100	31.2
			Low w/Coil	1085	30.7	1055	29.9	1025	29.0	1005	28.5	980	27.8
70/56 (20.5/16.4)	1725 (48.9)	A	High No Coil	1800	51.0	1760	49.9	1725	48.9	1680	47.6	1650	46.7
			High w/Coil	1535	43.5	1505	42.6	1480	41.9	1445	40.9	1410	39.9
			Low No Coil	1270	36.0	1240	35.1	1215	34.4	1185	33.6	1100	31.2
			Low w/Coil	1085	30.7	1055	29.9	1025	29.0	1005	28.5	980	27.8
77/62 (22.5/18.5)	1725 (48.9)	A	High No Coil	1800	51.0	1760	49.9	1725	48.9	1680	47.6	1650	46.7
			High w/Coil	1535	43.5	1505	42.6	1480	41.9	1445	40.9	1410	39.9
			Low No Coil	1270	36.0	1240	35.1	1215	34.4	1185	33.6	1100	31.2
			Low w/Coil	1085	30.7	1055	29.9	1025	29.0	1005	28.5	980	27.8
90/72 (26.3/21.1)	1725 (48.9)	A	High No Coil	1800	51.0	1760	49.9	1725	48.9	1680	47.6	1650	46.7
			High w/Coil	1535	43.5	1505	42.6	1480	41.9	1445	40.9	1410	39.9
			Low No Coil	1270	36.0	1240	35.1	1215	34.4	1185	33.6	1100	31.2
			Low w/Coil	1085	30.7	1055	29.9	1025	29.0	1005	28.5	980	27.8

TABLE 10: AC Accessories

MODEL NO.	DESCRIPTION	USED WITH
7900-7761	AC CONTROL KIT	A/C RELAY FOR DGPH MODELS
7900-7741/A	4 TON BLOWER	4 TON, 2 SPEED BLOWER FOR DGPH, DGPA
7900-7751	5 TON BLOWER	5 TON, 4 SPEED BLOWER FOR ALL MODELS
1PS0166	HIGH ALTITUDE KIT FOR NATURAL GAS	ALL MODELS
1PS0167	HIGH ALTITUDE KIT FOR PROPANE (LP) GAS	ALL MODELS

FIGURE 32: Wiring Diagram - DGAA

BLOWER SPEED CHART (CHARTÉ DE VITESSE DE LA SOUFFLERIE)

INPUT (ENTRÉE)	CFM (PCM)	COOL HIGH (CLIMA)	HEAT (CHAUF)
056	1200	BLK (NOIR)	RED (ROUGE)
070	1200	BLK (NOIR)	RED (ROUGE)
077	1200	BLK (NOIR)	RED (ROUGE)
090	1200	BLK (NOIR)	RED (ROUGE)

WIRE COLOR KEY (CODE DE COULEUR DU FILAGE)

BLK (NOIR)	BLACK (NOIR)
BLU (BLEU)	BLUE (BLEU)
RED (ROUGE)	RED (ROUGE)
YEL (JAUNE)	YELLOW (JAUNE)
WHT (BLANC)	WHITE (BLANC)
BRN (BRUN)	BROWN (BRUN)
GRN (VERT)	GREEN (VERT)
PRP (POURPRE)	PURPLE (POURPRE)
ORA (ORANGE)	ORANGE (ORANGE)

- CAUTION -
OPEN ALL DISCONNECTS BEFORE SERVICING THIS UNIT
- PRECAUTION -
OUVREZ LES DISJONCTEURS AVANT DE PROCÉDER AVEC LE SERVICE

80% DOWNFLOW FURNACE (FOURNAISE 80% VENTILÉE PAR LE BAS)

LADDER DIAGRAM (DIAGRAMME ÉLÉMENTAIRE)

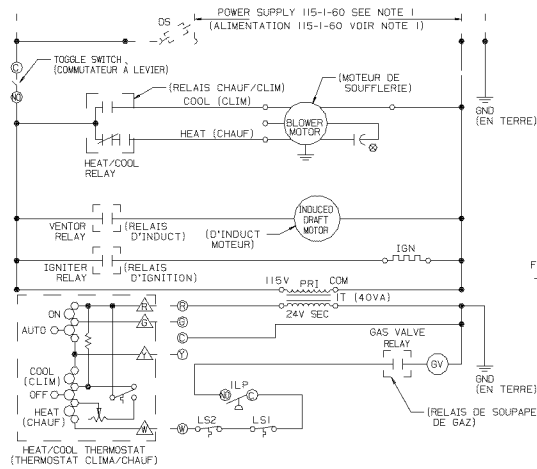

NOTES:

- ALL FIELD WIRING PER: (A) NATIONAL L. ELEC. CODE (NEC) AND/OR/ (B) CANADIAN N. ELEC. CODE (CEC) AND/OR/ (C) LOCAL OR R CITY CODES. APPLIED WITH THE FURNACE MUST BE WITH WIRING MATERIAL HAVING A TEMPERATURE RATING OF AT LEAST 22 °F (105°C).
- IF ANY OF THE ORIGINAL WIRE AS SUPPLIED WITH THE FURNACE MUST BE REPLACED, IT MUST BE REPLACED WITH WIRING MATERIAL HAVING A TEMPERATURE RATING OF AT LEAST 22 °F (105°C).
- CONNECTORS SUITABLE FOR COPPER OR ALUMINUM SUPPLIES.
- ALL REPLACEMENT COMPONENTS MUST BE PROPERLY GROUNDED.
- PROVIDE DISCONNECTS FOR ALL POWER SUPPLIES.
- MOTORS ARE INHERENTLY PROTECTED.
- SSI IS IN SERIES WITH LSI AND LS2.

NOTES:

- TOUT FILAGE EN CHANTIER SELON: (A) CODE ELEC. NATIONAL (CEN) ET/OU/ (B) CODE ELEC. CANADIEN (CEC) ET/OU/ (C) CODES LOCAUX ET MUNICIPAUX.
- SI LE FILAGE DOIT ÊTRE REMPLACÉ, IL DOIT ÊTRE REMPLACÉ AVEC UN MATÉRIEL POUVANT RÉSISSER A DES TEMPÉRATURES D'AU MOINS 22°F (105°C).
- SEULEMENT DES MARETTES POUR FIL D'ALUMINUM ET D'ÉTAIN.
- TOUTE COMPOSANTE DE REMPLACEMENT DOIT ÊTRE BIEN MISE EN TERRE.
- FOURNISSEZ LES DISJONCTEURS POUR LEUR CONCEPTION.
- LES MOTEURS SONT PROTÉGÉS DE SURCHARGE PAR LEUR CONCEPTION.
- SSI DE SÉRIE AVEC LSI ET LS2.

CONNECTION DIAGRAM (DIAGRAMME DE RACCORDEMENT)

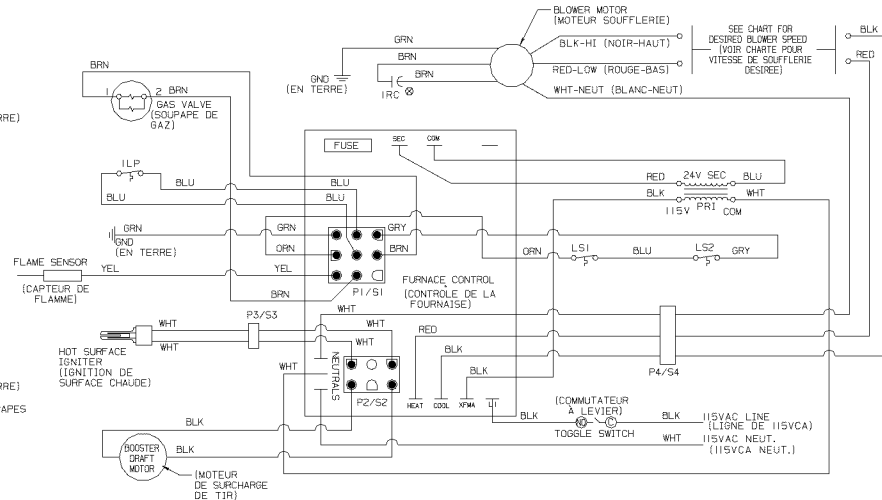

LEGEND

- DS DISCONNECT SWITCH
- GV GAS VALVE
- IGN HOT SURFACE IGNITER
- P1/S1 9 PIN PLUG & SOCKET ON FURNACE CONTROL BOARD
- P2/S2 6 PIN PLUG & SOCKET ON FURNACE CONTROL BOARD
- P3/S3 2 PIN PLUG & SOCKET AT HOT SURFACE IGNITER
- P4/S4 9 PIN PLUG & SOCKET
- LS1,2 AUXILIARY LIMIT SWITCH ON BLOWER INLET
- ILP PRESSURE SWITCH
- IRC RUN CAPACITOR
- IT TRANSFORMER, 40VA
- ⊗ IDENTIFIED RUN CAPACITOR
- △ 24V CONNECTION ROOM THERMOSTAT
- FIELD CONNECTION
- FACTORY WIRING AND DEVICES
- FIELD WIRING AND DEVICES
- [] RELAY CONTACTS ON IGNITION CONTROL BOARD

LEGENDE

- DS COMMUTATEUR DE DISJONCTION
- GV SOUPAPE DE GAZ
- IGN IGNITION DE SURFACE CHAUDE
- P1/S1 PRISE & RECEPTACLE A 9 PTS SUR LA PLAQUETTE DE CONTROLE D'IGNITION
- P2/S2 PRISE & RECEPTACLE A 6 PTS SUR LA PLAQUETTE DE CONTROLE D'IGNITION
- P3/S3 PRISE ET RECEPTACLE A 2 PTS SUR LA PLAQUETTE DE SURFACE CHAUDE
- P4/S4 PRISE ET RECEPTACLE A 9 PTS
- LS1,2 COMMUTATEUR AUXILIAIRE DE PRESSION SUR BOITIER DE SOUFFLERIE
- ILP COMMUTATEUR DE PRESSION
- IRC CAPACITEUR DE FONCTIONNEMENT IDENTIFIE
- IT TRANSFORMEUR, 40VA
- ⊗ CAPACITEUR DE FONCTIONNEMENT IDENTIFIE
- △ 24V RACCORDEMENT DU THERMOSTAT DE PIÈCE
- RACCORDEMENT DE CHANTIER
- FILAGE DE L'USINE ET APPAREILS
- FILAGE DE CHANTIER ET APPAREILS
- [] CONTACTS DES RELAIS SUR LA PLAQUETTE DE CONTROLE D'IGNITION

155887-UWD-A-0705

FIGURE 33: Wiring Diagram - DG4H

WIRE COLOR KEY
(CODE DE COULEUR
DU FILAGE)

BLK (NOIR)	BLACK (NOIR)
BLU (BLEU)	BLUE (BLEU)
RED (ROUGE)	RED (ROUGE)
YEL (JAUNE)	YELLOW (JAUNE)
WHT (BLANC)	WHITE (BLANC)
BRN (BRUN)	BROWN (BRUN)
GRN (VERT)	GREEN (VERT)
PUR (POURPRE)	PURPLE (POURPRE)
ORN (ORANGE)	ORANGE (ORANGE)

- CAUTION -
OPEN ALL DISCONNECTS BEFORE
SERVICING THIS UNIT

- PRECAUTION -
OUVREZ LES DISJONCTEURS AVANT
DE PROCÉDER AVEC LE SERVICE

LADDER DIAGRAM
(DIAGRAMME ÉLÉMENTAIRE)

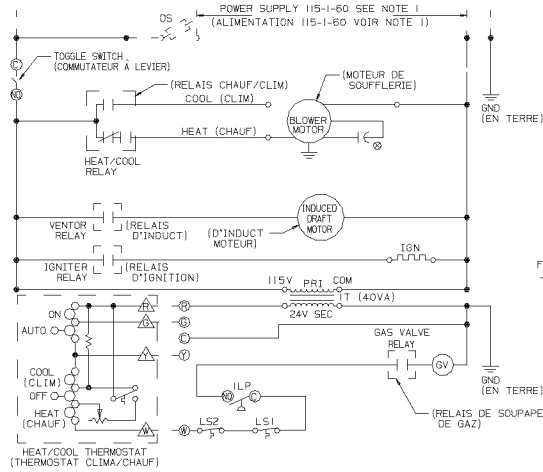

NOTES:

- ALL FIELD WIRING PER: (A) NATIONAL, (B) CANADIAN, (C) LOCAL OR CITY CODES.
- IF ANY OF THE ORIGINAL WIRE AS SUPPLIED WITH THE FURNACE MUST BE REPLACED, IT MUST BE REPLACED WITH WIRING MATERIAL HAVING A TEMPERATURE RATING OF AT LEAST 221°F (105°C).
- CONNECTORS SUITABLE FOR COPPER CONDUCTORS ONLY.
- ALL REPLACEMENT COMPONENTS MUST BE PROPERLY GROUNDED.
- PROVIDE DISCONNECTS FOR ALL POWER SUPPLIES.
- MOTORS ARE INHERENTLY PROTECTED.
- SSI IS IN SERIES WITH LSI AND LS2.

NOTES:

- TOUT FILAGE EN CHANTIER SELON: (A) CODE ELEC. NATIONAL (CEN) ET/OU (B) CODE ELEC. CANADIEN (CEC) ET/OU (C) CODES LOCAUX ET MUNICIPAUX.
- SI LE FILAGE DOIT ÊTRE REMPLACÉ, IL DOIT ÊTRE REMPLACÉ PAR UN MATÉRIEL POUVANT RÉSISSER À DES TEMPÉRATURES D'AU MOINS 221°F (105°C).
- SEULEMENT DES MARETTES POUR FIL D'ÉLECTRIFICATION EN CUivre.
- TOUTE COMPOSANTE DE REMPLACEMENT DOIT ÊTRE BIEN MISE EN TERRE.
- FOURNISSEZ LES DISJONCTEURS POUR L'ALIMENTATION.
- LES MOTEURS SONT PROTÉGÉS PAR LEUR CONCEPTION.
- SSI DE SÉRIE AVEC LSI ET LS2.

CONNECTION DIAGRAM
(DIAGRAMME DE RACCORDEMENT)

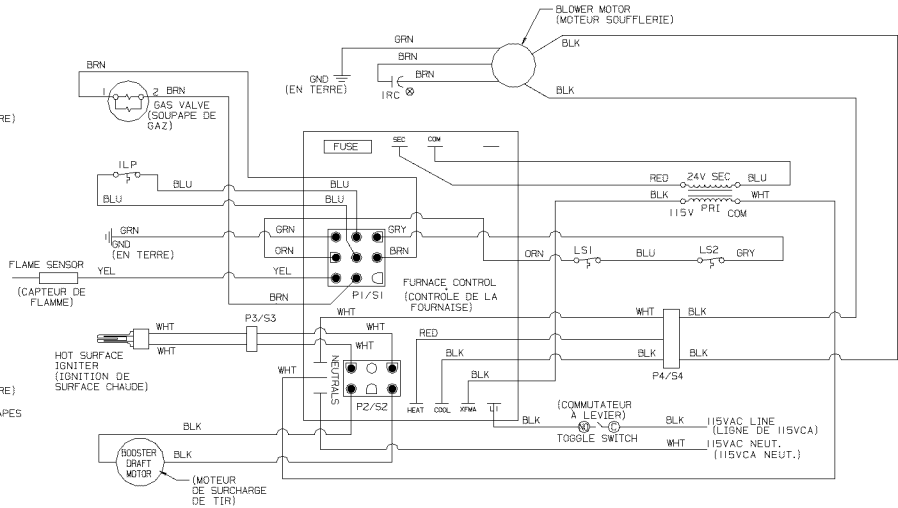

LEGEND

- DS DISCONNECT SWITCH
- GV GAS VALVE
- IGN HOT SURFACE IGNITER
- P1/S1 9 PIN PLUG & SOCKET ON FURNACE CONTROL BOARD
- P2/S2 6 PIN PLUG & SOCKET ON FURNACE CONTROL BOARD
- P3/S3 2 PIN PLUG & SOCKET AT HOT SURFACE IGNITER
- P4/S4 9 PIN PLUG & SOCKET
- ILP PRESSURE SWITCH
- LS1,2 AUXILIARY LIMIT SWITCH ON BLOWER INLET
- IRC RUN CAPACITOR
- IT TRANSFORMER, 40VA
- ⊗ IDENTIFIED RUN CAPACITOR
- △ 24V CONNECTION ROOM THERMOSTAT
- FIELD CONNECTION
- FACTORY WIRING AND DEVICES
- FIELD WIRING AND DEVICES
- [] RELAY CONTACTS ON IGNITION CONTROL BOARD

LEGENDE

- DS COMMUNIFICATEUR DE DISJONCTION
- GV SOUPAPE DE GAZ
- IGN IGNITION DE SURFACE CHAUDE
- P1/S1 PRISE & RECEPTACLE A 9 PTS SUR LA PLAQUETTE DE CONTROLE D'IGNITION
- P2/S2 PRISE & RECEPTACLE A 6 PTS SUR LA PLAQUETTE DE CONTROLE D'IGNITION
- P3/S3 PRISE ET RECEPTACLE A 2 PTS D'IGNITION DE SURFACE CHAUDE
- P4/S4 PRISE ET RECEPTACLE A 9 PTS
- LS1,2 COMMUNIFICATEUR AUXILIAIRE DE PRESSION SUR BOITIER DE SOUFFLERIE
- ILP COMMUNIFICATEUR DE PRESSION
- IRC CAPACITEUR DE FONCTIONNEMENT IDENTIFIE
- IT TRANSFORMEUR, 40VA
- ⊗ CAPACITEUR DE FONCTIONNEMENT IDENTIFIE
- △ 24V RACCORDEMENT DU THERMOSTAT DE PIECE
- RACCORDEMENT DE CHANTIER
- FILAGE DE L'USINE ET APPAREILS
- FILAGE DE CHANTIER ET APPAREILS
- [] CONTACTES DES RELAIS SUR LA PLAQUETTE DE CONTROLE D'IGNITION

80% DOWNFLOW FURNACE

(FOURNAISE 80%
VENTILEE PAR LE BAS)

157953-UWD-A-0705

NOTES