



## Training Guide

**EASY 412-DC-...**  
**EASY 412-AC-...**  
**Control Relay**

**EASY 618-AC-RC**  
**EASY 620-DC-TC**

---

### **06/99 AWB 2528-1316 GB**

1st published 1998, edition 04/98

2nd published 1999, edition 06/99

see list of revisions on page II

© Moeller GmbH, Bonn

Author: Dieter Bauerfeind

Editor: Jörg Eiserloh, Thomas Kracht

Translator: Terence Osborn



## Caution!

### Dangerous electrical voltage!

#### Before commencing the installation

- Disconnect the power supply of the device.
- Ensure that the device cannot be accidentally restarted.
- Verify isolation from the supply.
- Earth and short circuit.
- Cover or enclose neighbouring units that are live.
- Follow the engineering instructions (AWA) of the device concerned.
- Only suitably qualified personnel may work on this device/system.
- Before installation and before touching the device ensure that you are free of electrostatic charge.
- Connecting cables and signal lines should be installed so that inductive or capacitive interference do not impair the automation functions.
- Install automation devices and related operating elements in such a way that they are well protected against unintentional operation.
- Suitable safety hardware and software measures should be implemented for the I/O interface so that a line or wire breakage on the signal side does not result in undefined states in the automation devices.
- Ensure a reliable electrical isolation of the low voltage for the 24 volt supply. Only use power supply units complying with IEC 60 364-4-41 or HD 384.4.41 S2.
- Deviations of the mains voltage from the rated value must not exceed the tolerance limits given in the specifications, otherwise this may cause malfunction and dangerous operation.
- Emergency stop devices complying with IEC/EN 60 204-1 must be effective in all operating modes of the automation devices. Unlatching the emergency-stop devices must not cause uncontrolled operation or restart.
- Devices that are designed for mounting in housings or control cabinets must only be operated and controlled after they have been installed with the housing closed. Desktop or portable units must only be operated and controlled in enclosed housings.
- Measures should be taken to ensure the proper restart of programs interrupted after a voltage dip or failure. This should not cause dangerous operating states even for a short time. If necessary, emergency-stop devices should be implemented.

---

*IBM* is a registered trademark of International Business Machines Corporation.

All other brand and product names are trademarks or registered trademarks of the owner concerned.

All rights reserved, including those of the translation.

No part of this manual may be reproduced in any form (printed, photocopy, microfilm or any other process) or processed, duplicated or distributed by means of electronic systems without written permission of Moeller GmbH, Bonn.

Subject to alterations without notice.

## List of revisions for the manual AWB 2528-1316 GB

Edition	Page	Title	New	Modified	Omitted
06/99	gen.	EASY 620-DC-TC EASY 618-AC-RC	×		
	4	Functions	×		
	5	“easy” at a glance		×	
	6	Mounting	×		
	6 ff.	Connecting “easy”	×		
	12	EASY 6... status display	×		
	14, 23 ff.	Circuit diagram elements		×	
	16	System menu	×		
	20	Menu languages	×		
	22	Startup behaviour	×		
	36	Text display (markers)	×		
	44	Available memory cards	×		
	44	EASY-SOFT		×	
	45	Technical data		×	
	47	Dimensions of EASY 6...		×	

# Contents

<b>1</b>	<b>“easy” Control Relay</b>	<b>3</b>
	Simply “easy”	3
	Mounting “easy”	6
	Connecting “easy”	6
	“easy” operating principle	11
<b>2</b>	<b>Drawing a Circuit with “easy”</b>	<b>19</b>
	Operation of “easy”	19
	Setting the menu language	20
	Setting the time	21
	Choose “easy” operating mode	22
	“easy”-Circuit diagram elements	23
	Example: creating a circuit diagram	26
	Function relay types	30
	Example: using a function relay	37
	Basic circuits	41
<b>3</b>	<b>“easy” Interface Socket</b>	<b>43</b>
<b>4</b>	<b>Technical Data</b>	<b>45</b>
	Technical data	45
	“easy” models	45
	<b>Index</b>	<b>49</b>

Contents

# 1 “easy” Control Relay

## Safety information



### **Danger of injury due to electric shock!**

The electrical installation and commissioning work must only be carried out by suitably qualified personnel.

Do not work on the device when the power is switched on.

Observe the relevant safety regulations:

- Switch off the power

- Make sure that the device cannot be switched on again inadvertently

- Check to make sure that no dangerous voltages are present before working on the device

- Cover up any neighbouring equipment which carries dangerous voltages

## Simply “easy”

## Clever switching and controlling

“easy” is a compact, user-friendly and low-cost control relay for simple control applications. Applications range from building and domestic automation to machine and plant control. “easy” has built-in user-friendly operating elements and an LCD display.

Just connect up “easy” and draw your circuit diagram on the display by pressing the buttons on the device. “easy” works with make contacts, break contacts, and relays.

Enter your circuit diagram in “easy” just like you sketched it on paper. “easy” has basic and advanced functions for relays, time switches and contactors, and lots more, too. You can make changes to your circuit just by pressing the buttons on the device. Time consuming rewiring is not necessary.

### **Applications everywhere**

Building and domestic automation, controllers for lighting, doors, window shutters...

Control ventilators, rotating doors, greenhouses, exterior lighting, window controllers, shop display lighting control...

Create controllers for temperature, ventilation and brightness levels...

Control machines and plant, presses, conveyor belts, oscillating conveyors, sorters, pumps...

### **Additional functions**

With the help of the additional 600 units - EASY 620-DC-TC, EASY 618-AC-RC - as well as the expansion of the 400 range with EASY 412-DC-TC, EASY 412-DC-TCX and EASY 412-AC-RCX, additional I/O and functions are now available, such as retentive counters, timing relays, markers and eight user-definable display texts.

The individual features of each control relay are described below.

Simply "easy"

### Overview of "easy"

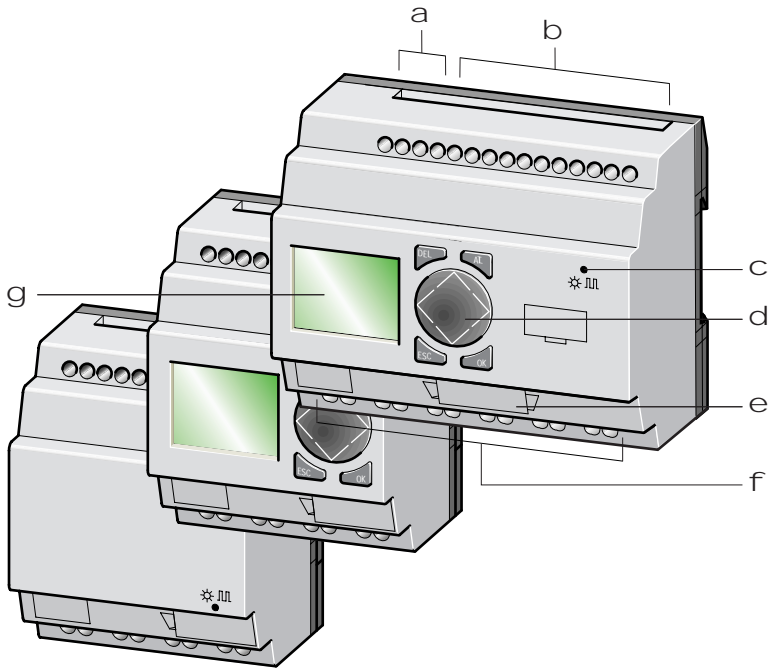

- a Power supply
- b Inputs
- c Buttons
- d Socket for memory card or PC interface cable
- e Output terminals
- f LCD display



### Mounting “easy”

#### Mounting on top-hat rail

Hook “easy” to the top edge of the top-hat rail and hinge into place while pressing down slightly as shown by the arrows.

“easy” will clip into place and will be secured by the built-in spring mechanism without needing screws.

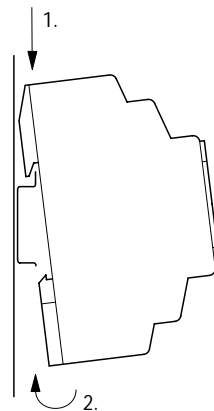

#### Mounting on a mounting plate

“easy” can be screwed to a mounting plate with the three device feet (available as an optional accessory).

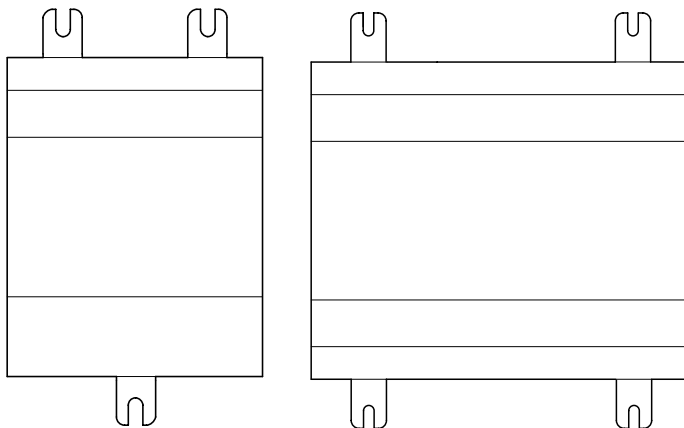

### Connecting “easy”

#### Overview

EASY...	412-DC-R...	412-DC-TC	412 AC-R...	618-AC-RC	620-DC-TC
Connecting inputs	Page 7	Page 7	Page 7	Page 9	Page 9
Connecting outputs	Page 8	Page 8	Page 8	Page 10	Page 10

### Inputs EASY 412-DC-...

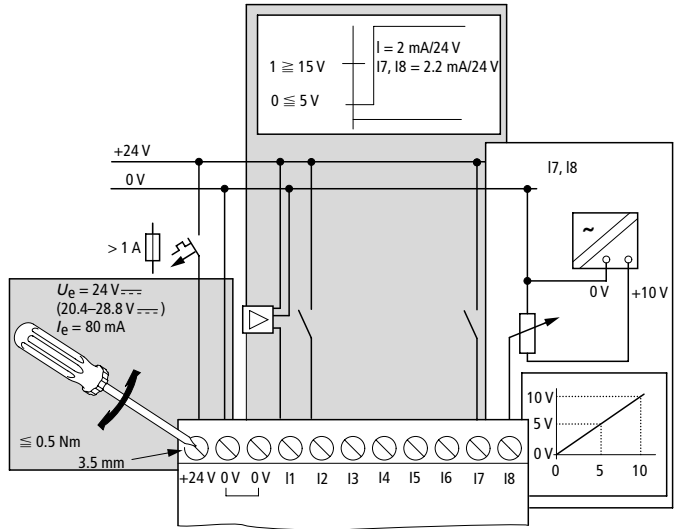

### Inputs EASY 412-AC-...

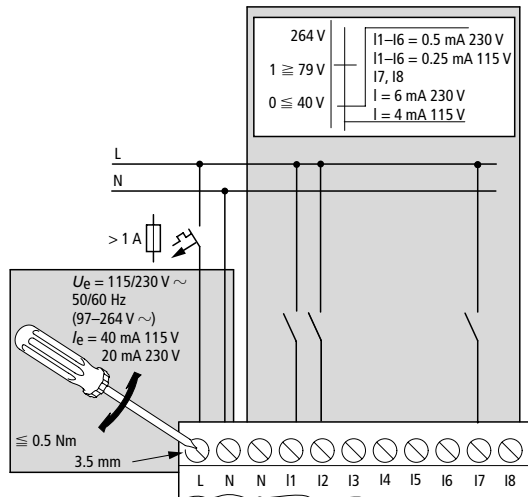

**Outputs EASY 412-AC-..., EASY 412-DC-R...**

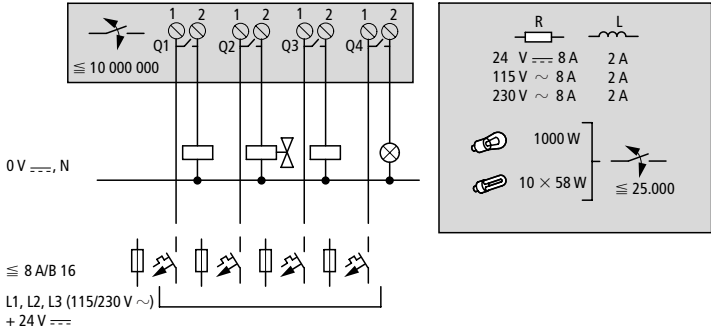

**Outputs EASY 412-DC-T...**

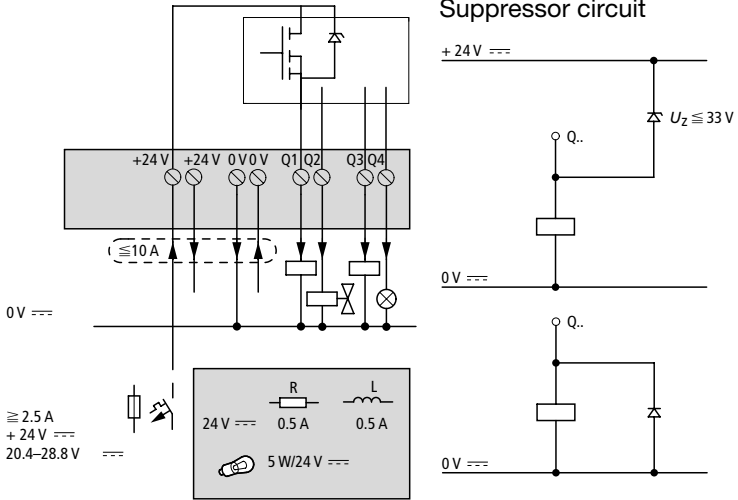

### Inputs EASY 620-DC-TC

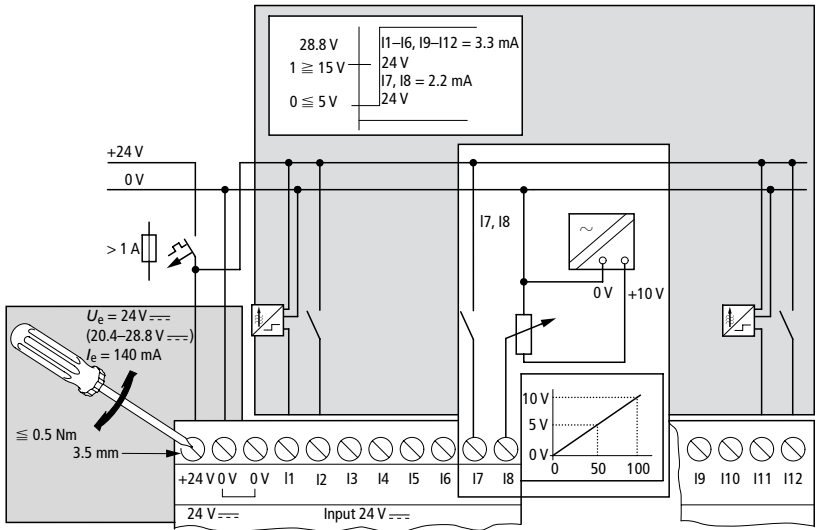

### Inputs EASY 618-AC-RC

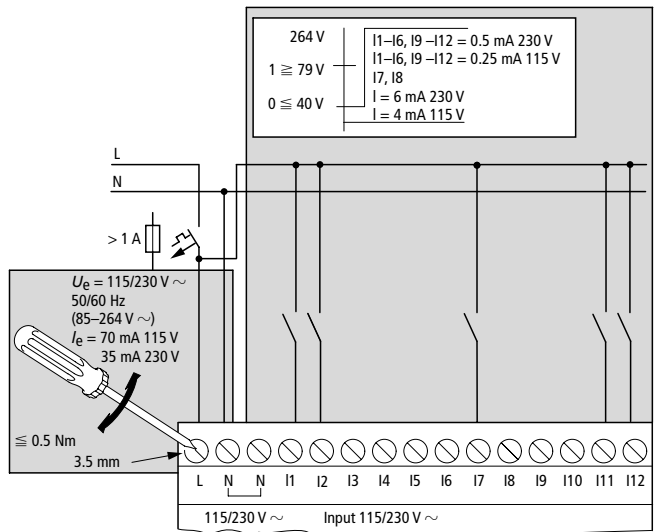

# “easy” Control Relay

## Outputs EASY 618-AC-RC

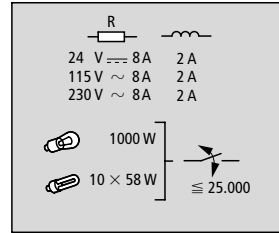
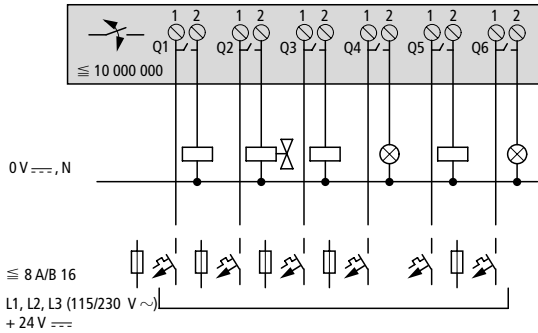

## Outputs EASY 620-DC-TC

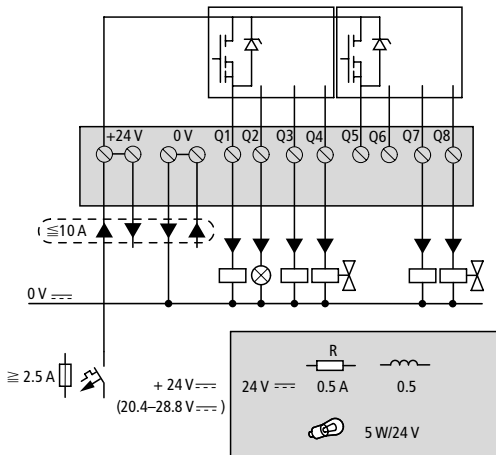

## Suppressor circuit

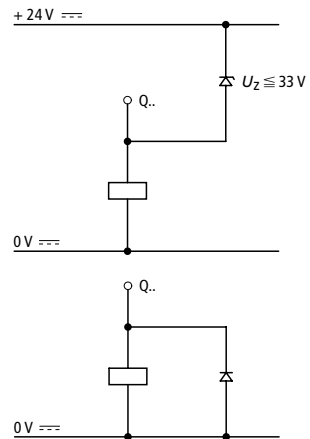

## “easy” operating principle

## “easy” operating buttons



**DEL:** Delete object in the circuit diagram

**ALT:** Special functions in the circuit diagram

**Cursor buttons** < > ^ ∨:

Move cursor,

Select menu item,

Choose contact numbers, values, time etc.

**OK:** Next menu level, store your entry

**ESC:** Last menu level, cancel your entry

## Moving through menus and choosing values

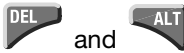

Show system menu



Go to next menu level

Select menu item

Store your entry



Return to last menu level

Cancel your entry since the last **OK**

^ ∨ Change menu item

Change value

< > Change position

P button function (if enabled):

< Input P1,

^ Input P2

> Input P3,

∨ Input P4

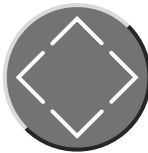

**EASY 412-...status display**

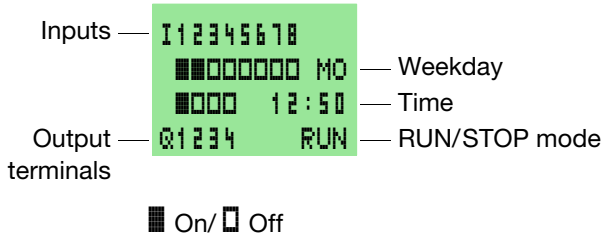

**Status display EASY 618-..., EASY 620-...**

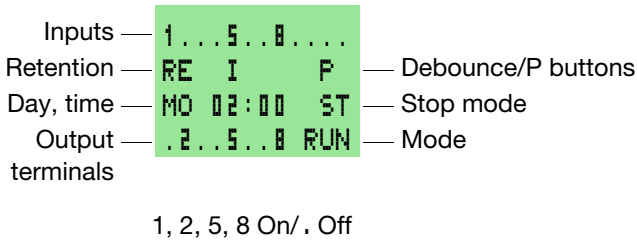

**Menu display**

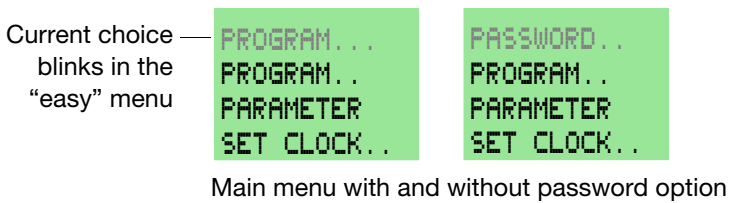

### Cursor display

The cursor blinks alternately:

Full blinking cursor █/█:

Move cursor with < > ,

In circuit diagram also with

^ v

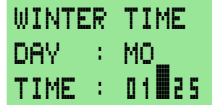

```
WINTER TIME
DAY : MO
TIME : 01:25
```

Value M/M

Change position with < >

Change values with ^ v

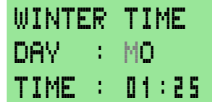

```
WINTER TIME
DAY : MO
TIME : 01:25
```

Blinking values/menus are shown grey in this manual.

### Circuit diagram menu

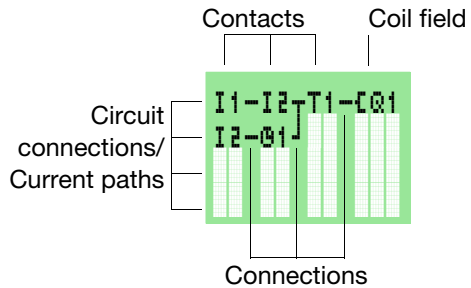



**Circuit diagram symbols**

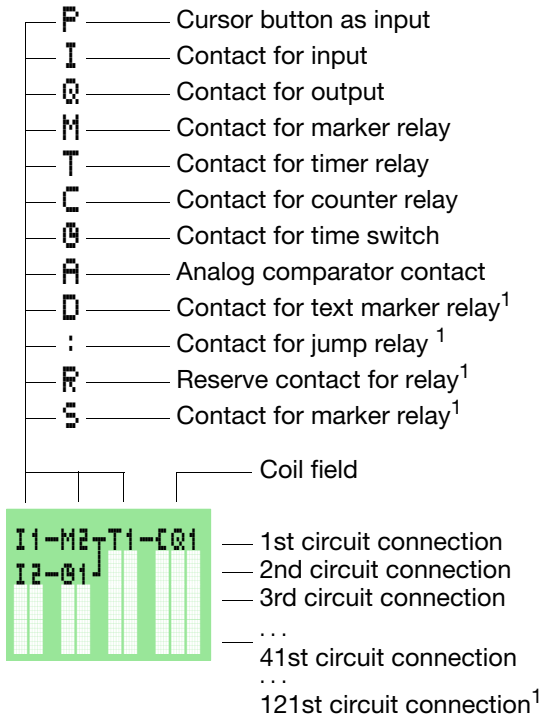

1 Only EASY 618/620

## Menu structure

### Main menu without optional password protection

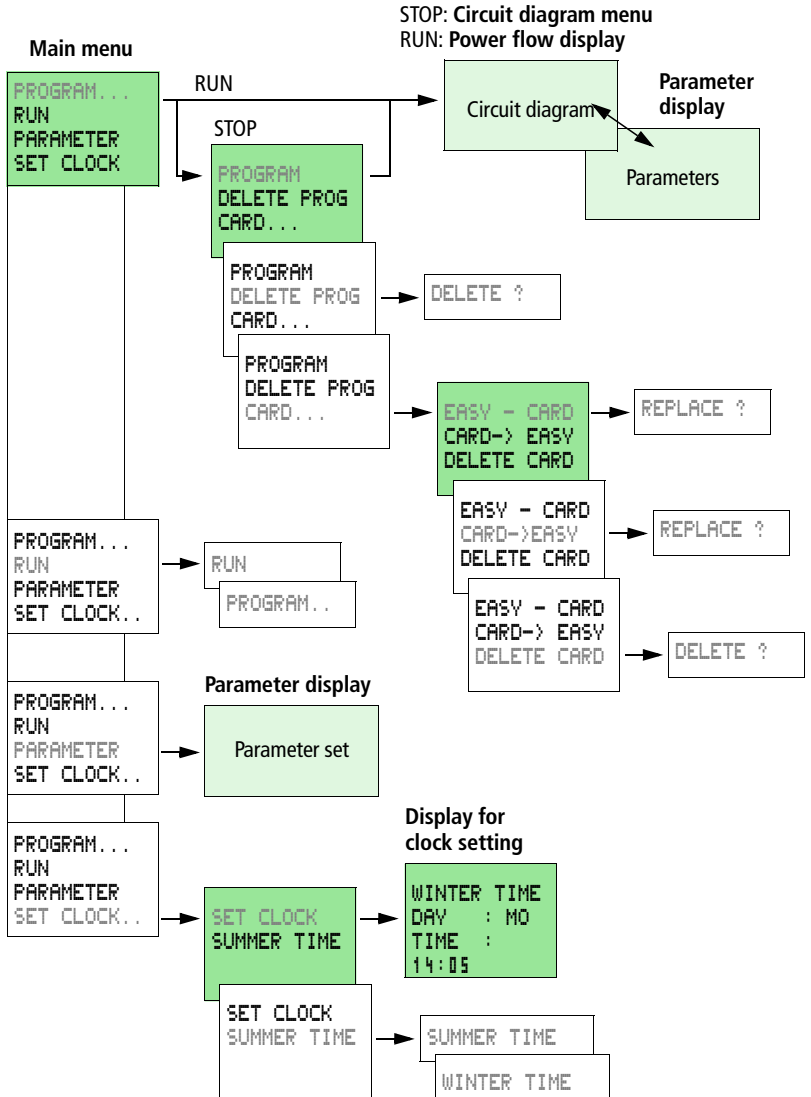

### Main menu with password protection

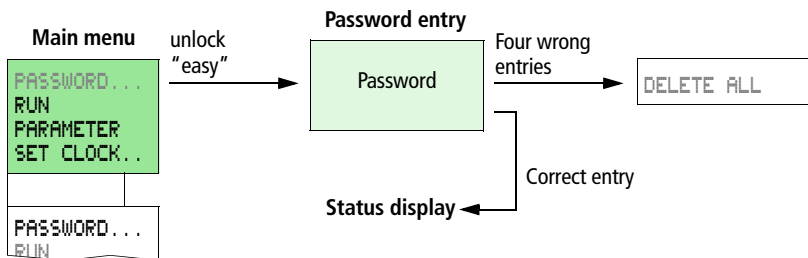

### System menu EASY 412-..., operating system V 1.0

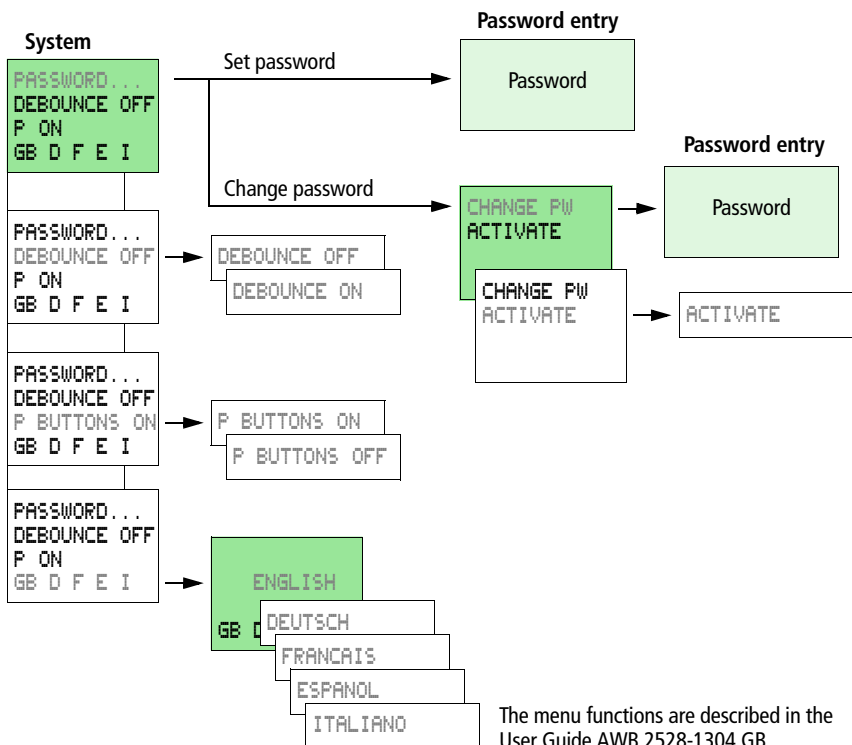

The menu functions are described in the User Guide AWB 2528-1304 GB.

**System menu EASY 412-..., operating system from V 1.2, EASY 618-AC-RC, EASY 620-DC-TC**

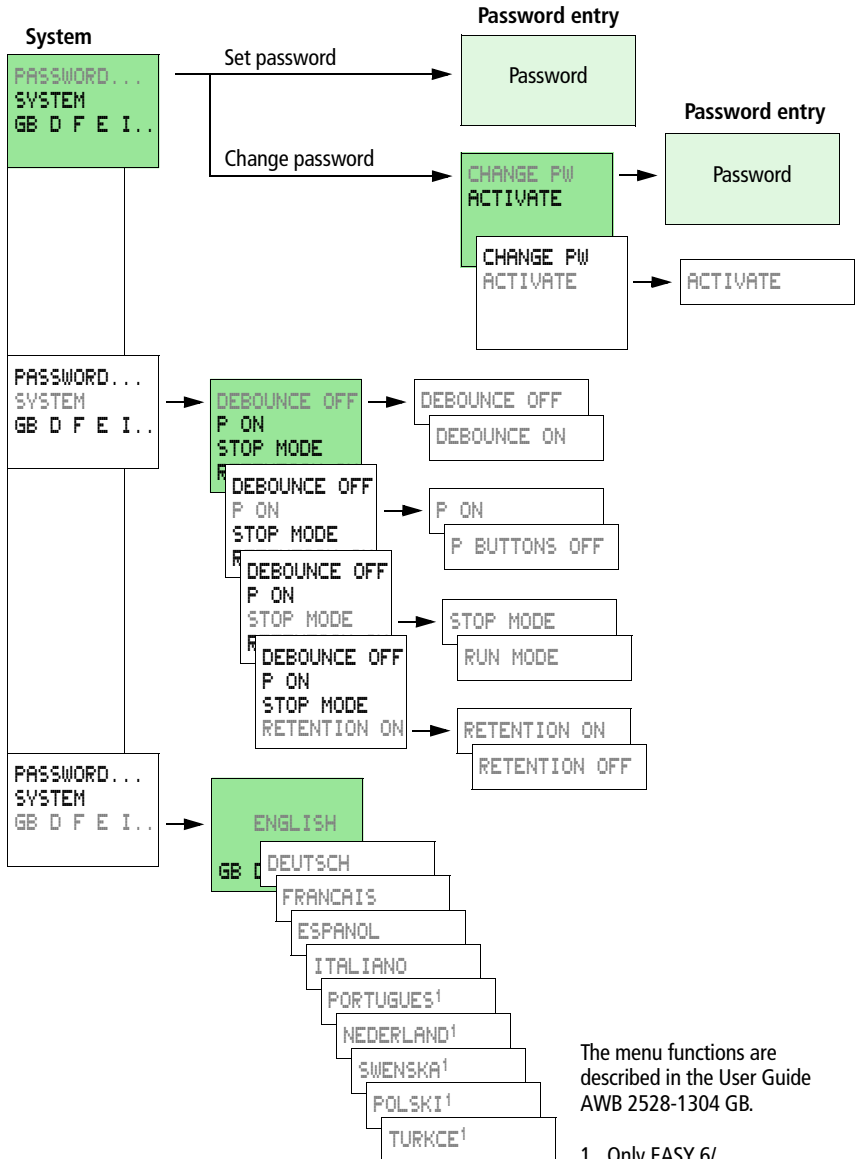

The menu functions are described in the User Guide AWB 2528-1304 GB.

1 Only EASY 6/...



## 2 Drawing a Circuit with “easy”

### Operation of “easy”

### Buttons for drawing circuit diagrams



Delete circuit connection, contact, relay or empty line in the circuit diagram



Toggle between break and make contact  
Connect contacts and relays  
Add circuit connections



^v Change value  
Move cursor up and down  
<> Change position  
Move cursor to left and right

Assign P buttons:

< Input P1, ^ Input P2  
> Input P3, v Input P4



Undo settings from previous **OK**  
Exit current display



Change, add contact/relay  
Save setting

## Setting the menu language

### Switching on “easy” for the first time

Choose menu language

- ▶ Choose language with the cursor keys  $\wedge \vee$

GB English  
D German  
F French  
E Spanish  
I Italian



EASY 600 also supports the following languages:

Portuguese  
Dutch  
Swedish  
Polish  
Turkish

- ▶ Confirm with **OK**.

“easy” then shows the status display

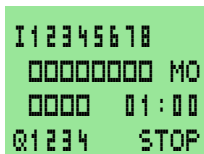

EASY 412-...

or

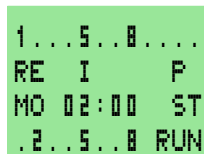

EASY 6...

## Setting the time

A clock is only provided in “easy” models with the type designation “...-C”.

### Switch to the Set Clock menu

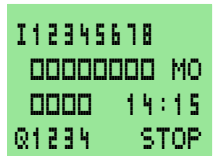

or

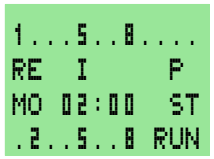

EASY 412-...



EASY 6...



### Setting week days and time







- < > Move cursor
- ^ v Change value



Save setting

or



Keep previous value



Exit menu



### Winter/summer time (DST)



Display: SUMMER TIME  
Winter time is set  
Display: WINTER TIME  
Summer time is set



Toggle settings



Exit menu

### Choose “easy” operating mode

The two “easy” operating modes are RUN or STOP.

RUN: “easy” processes the circuit diagram.

STOP: Draw the circuit diagram.

The alternating RUN/STOP menu shows either RUN or STOP as follows:



STOP mode active: RUN is shown

RUN mode active: STOP is shown

### Selectable startup behaviour

With EASY 412-... units using operating system V 1.2, EASY 618-... and EASY 620-... it is possible to select the operating mode to be activated when the power supply is switched:

Startup in “RUN” mode

or

Startup in “STOP” mode

### Retentive actual values

With EASY 412-DC-... using operating system V 1.2, EASY 620-DC-TC and EASY 618-AC-RC it is possible to save the actual values of markers and counters, also in the event of a power failure.

EASY 412-DC-...

- 4 marker relays (markers)
- 1 timing relay
- 1 counter

EASY 620-DC-TC, EASY 618-AC-RC

- 12 marker relays (markers), text display
- 2 timing relays
- 4 counters

For further information see AWB 2528-1304 GB.

**“easy” circuit diagram elements      Contacts**

Contact type	Make contact	Break contact	EASY 412	EASY 6...
“easy” input terminal	I	$\bar{I}$	I1...I8	I1...I12
P button contact (cursor keys)	P	$\bar{P}$	P1...P4	P1...P4
“easy” output relay contact	Q	$\bar{Q}$	Q1...Q4	Q1...Q8
Marker relay contact	M	$\bar{M}$	M1...M16	M1...M16
Counter relay contact	C	$\bar{C}$	C1...C8	C1...C8
Timing relay contact	T	$\bar{T}$	T1...T8	T1...T8
Time switch contact	Ø	$\bar{Ø}$	Ø1...Ø4	Ø1...Ø4
Analog comparator contact	A	$\bar{A}$	A1...A8	A1...A8
Text display contact	D	$\bar{D}$	–	D1...D8
Jump contact	:	–	–	:1...:8
Marker relay contact	S	$\bar{S}$	–	S1...S8
Reserve	R	$\bar{R}$	–	R1...R16
Short-circuit detection EASY...-DC-T..	I	$\bar{I}$	I16	I15, I16

### Relays

Relay type	“easy” symbol	EASY 412	EASY 6...	Coil function	Parameter
“easy” input terminal	I	I1...I8	I1...I12	–	–
P button contact (cursor keys)	P	P1...P4	P1...P4	–	–
“easy” output relay contact	Q	Q1...Q4	Q1...Q8	X	–
Marker relay contact	M	M1...M16	M1...M16	X	–
Counter relay contact	C	C1...C8	C1...C8	X	X
Timing relay contact	T	T1...T8	T1...T8	X	X
Time switch contact	Q	Q1...Q4	Q1...Q4	–	X
Analog comparator relay	A	A1...A8	A1...A8	–	X
Text display contact	D	–	D1...D8	X	X
Jump contact	:	–	:1...:8	X	–
Marker relay contact	S	–	S1...S8	X	–
Reserve	R	–	R1...16	–	–
Short-circuit detection EASY...DC-T...	I	I16	I15, I16	–	–

### Retentive relays

Relay type	“easy” symbol	EASY 412	EASY 6...
Marker relay contact	M	M13...M16	M13...M16
Counter relay contact	C	C8	C5, C6, C7, C8
Timing relay contact	T	T8	T1, T8
Text display contact	D	–	D1...D8



### Basic relays with contactor function

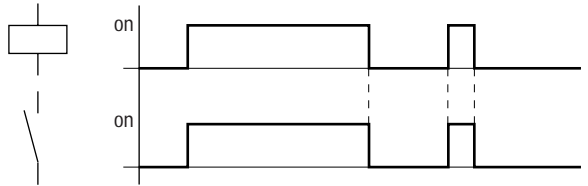

### Impulse relay

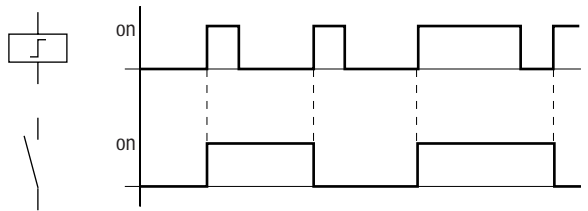

### Latching relay

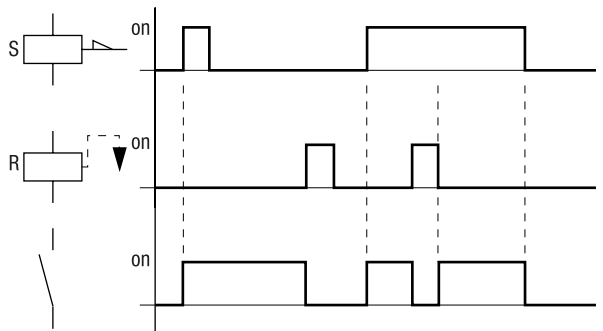

# Drawing a Circuit with "easy"

## Example: creating a circuit diagram

## Interconnecting contacts and relays

Conventional circuit

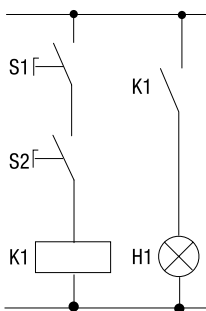

"easy" circuit diagram

**Connecting up "easy"**  
 Connect S1 to "easy" input terminal I1  
 Connect S2 to "easy" input I2  
 Connect load H1 to "easy" output Q1

"easy" circuit diagram



## Draw circuit in circuit diagram menu...

Start Status display

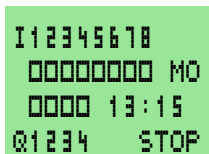

or

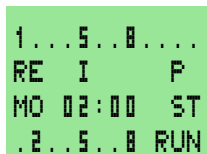

EASY 412-...

EASY 6...



## Insert contact "I1"

Circuit diagram display

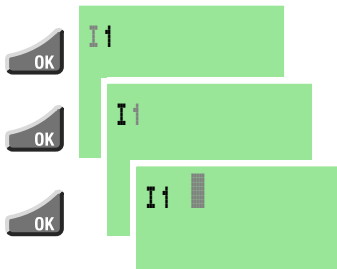

### Insert contact "I2"

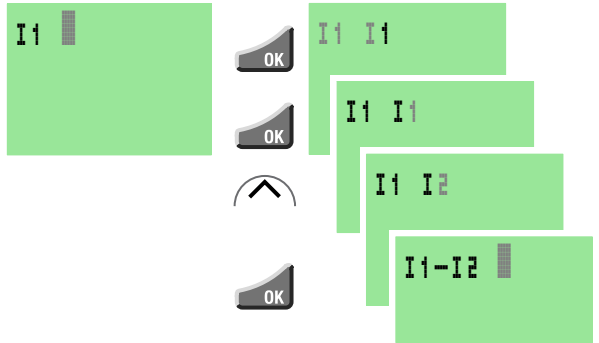

### Draw connection between contact and relay coil

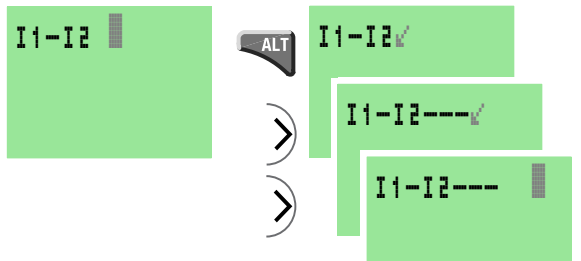

### Choose relay coil "Q1"

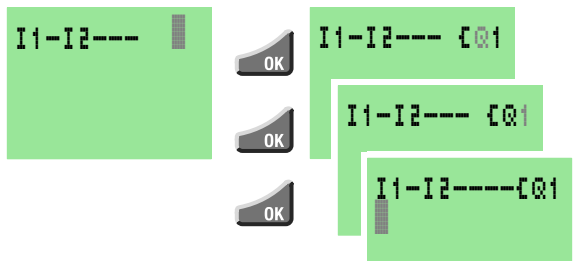

### Change operating mode

"easy" circuit diagram

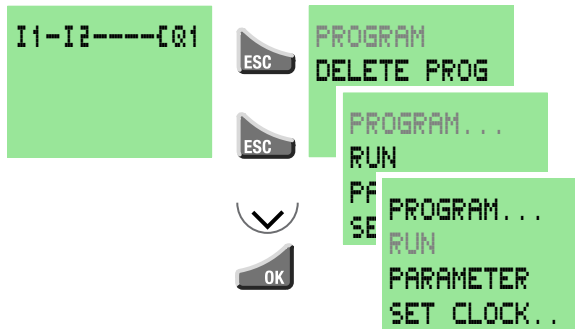

"easy" now in RUN mode

### Test circuit diagram

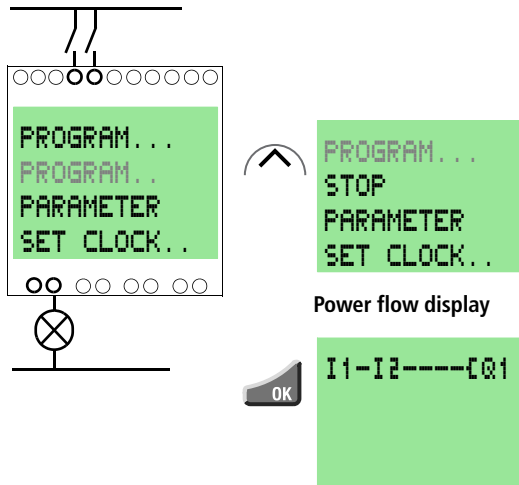

Power flow display

Example: creating a circuit diagram

### Operate switch "S1" and "S2"

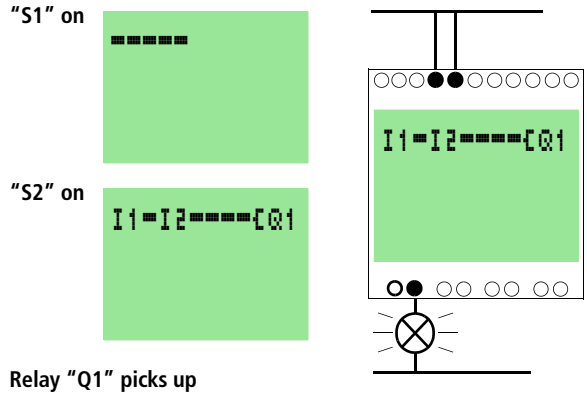

### Return to status display with ESC

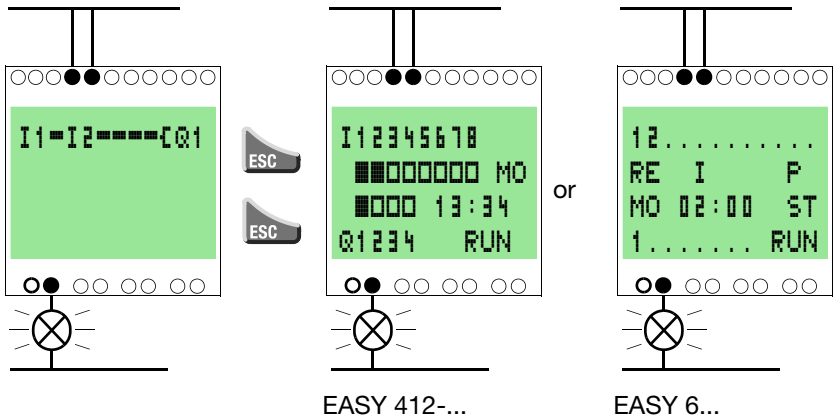

In the next example, a timing relay will be added to the circuit.



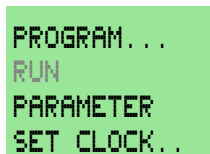

Status display is activated.

Choose STOP mode:



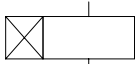

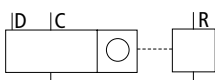
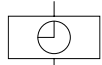
### Function relay types

Circuit diagram symbol	Function relay type
	Timing relay with on delay with and without random switching
	Timing relay, off-delayed with and without random switching
	Timing relay, single pulse Timing relay, flashing
	Counter relay, up/down counter
	Time switch, weekday/time (only in “easy” models with clock)
	Analog comparator relay (only in “easy” models for 24 V DC)

### Timing relay

 **Timing relay with on delay, with and without random switching**

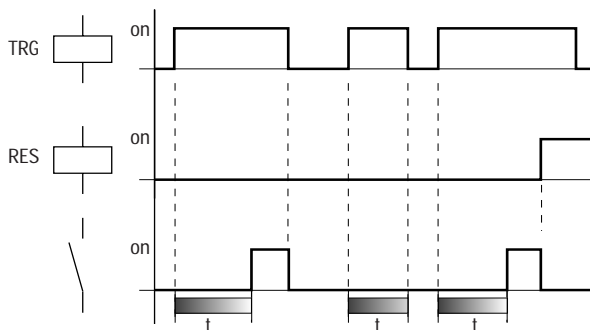

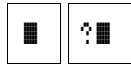

**Timing relay, off-delayed, with and without random switching**

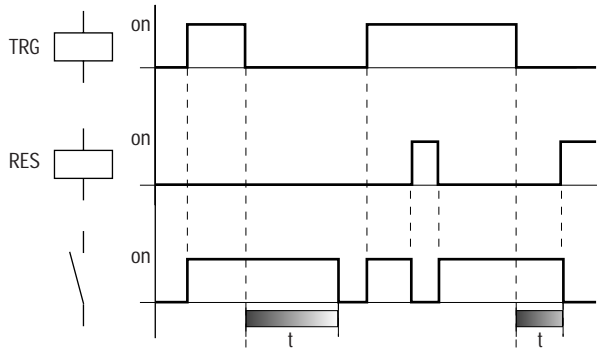

With random switching, the relay contact switches randomly at any time up to the specified time value (shown shaded in figure).



**Timing relay, single pulse**

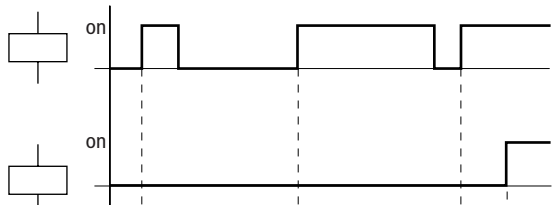



### Timing relay, flashing

$$\text{Flash frequency} = \frac{1}{2 \times \text{Setpoint}}$$

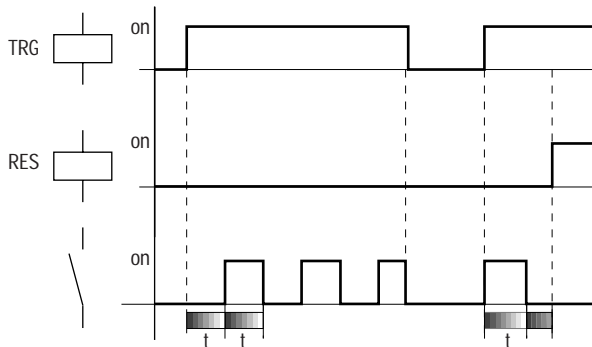

### Parameter display for timing relays

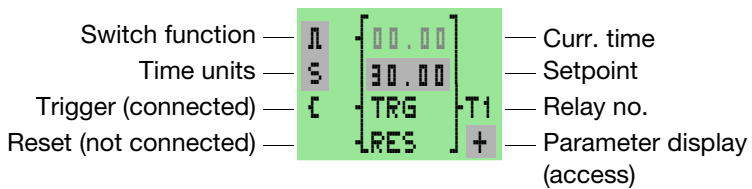

### Counter relay

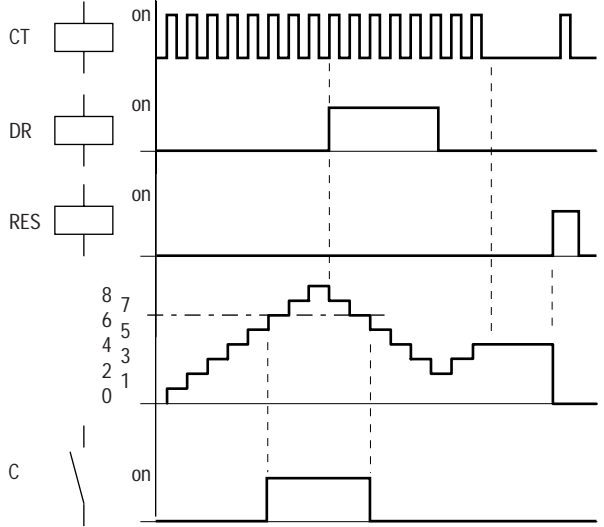

Setpoint = 6

### Parameter display for counter relays

Setpoint	—	[ 0230 ]	0000	—	Curr. value
Opt. direction (connected)	[	DIR	]		Setpoint
Opt. counter (connected)	[	CNT	]	C1	Relay no.
Reset (not connected)	[	RES	]	+	Parameter display (access)

### Time switch

**Example:** Time switch "01" switches on Mondays to Fridays between 6:30 and 9:00 and between 17:00 and 22:30.

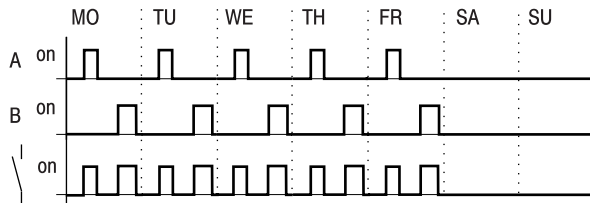
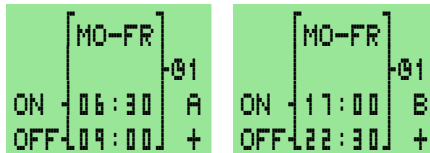

### Parameter display for time switches

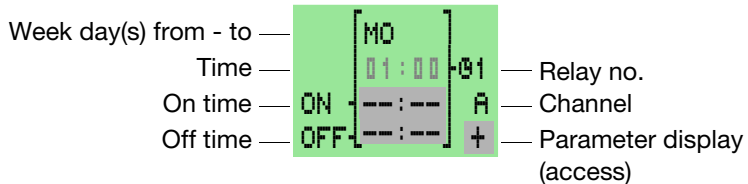

### Analog comparator

Available functions:

$I7 \geq I8, I7 \leq I8$

$I7 \geq \text{Setpoint}, I7 \leq \text{Setpoint}$

$I8 \geq \text{Setpoint}, I8 \leq \text{Setpoint}$

The analog comparator can compare voltages from 0 V to 10 V (setpoints “0.0” to “10.0”).



Analog signals of sensors typically fluctuate by several millivolts. For stable set and reset switching the setpoints should differ by at least 0.2 V (switching hysteresis). Do not use any relay with contactor or impulse relay coil functions.

### Parameter displays for analog comparators

Compare inputs “I7” and “I8”

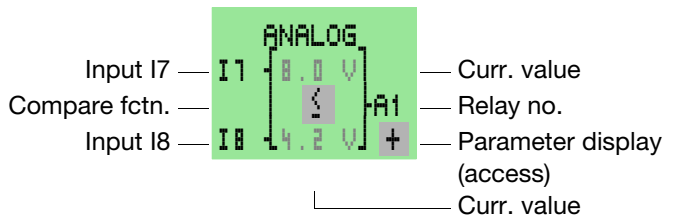

Compare input “I7” or “I8” with program setpoint

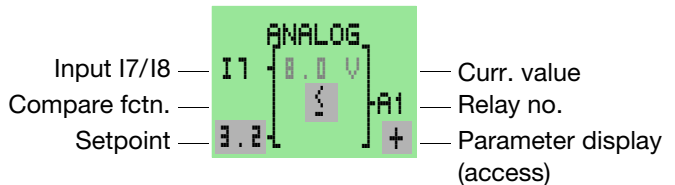

### Text display (Marker)

The markers can be used to display eight freely definable texts. Each text block can display up to 48 characters from the easy display character set (ASCII + easy special characters). If the coil of a marker is "1", the text entered via EASY-SOFT V 2.0 will be displayed. If several text markers are "1", the next text is displayed every 4 seconds. When text marker D1 is "1" it stays displayed (fault indication).

Press OK to switch to the menus at any time.

Current values or parameters of function relays can be displayed in lines 2 and 3.

Examples:

Fault signals

```
CAUTION !  
PUMP 1  
MOTOR  
MALFUNCTION
```

Time with text display

```
THE TIME  
IS  
14:42
```

Showing scaled analog values

```
EXTERNAL  
TEMPERATURE  
020 0 C  
HEAT !
```

Display current value and parameter of timing relay

```
TIMING RELAY  
1  
SETP49.00 S  
ACTV 42.00 S
```

Display counter value

```
QUANTITY  
ACTV 0042  
PCS  
SETP0100
```

Example: using a function relay

**Example: using a function relay**

Conventional circuit

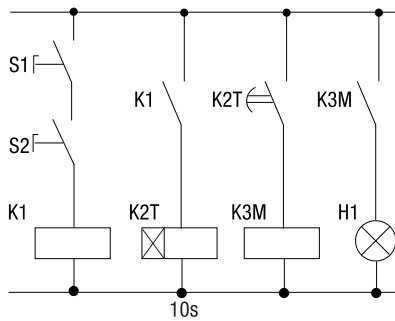

"easy" circuit diagram  
 "easy" switches H1 with 10 seconds delay.

"easy" circuit diagram

```
I1-I2----[M1
M1-----TT1
T1-----[Q1
```

**Select marker relay**

Start Circuit from first example

Position cursor on "Q"

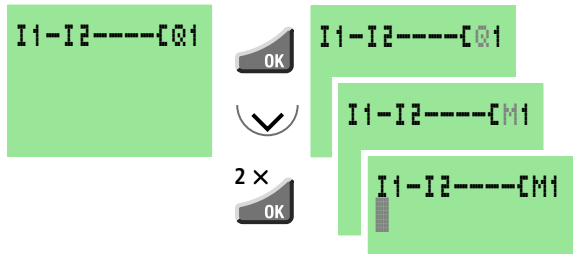

Select marker relay contact and connect to new



Drawing a Circuit with  
“easy”

output relay

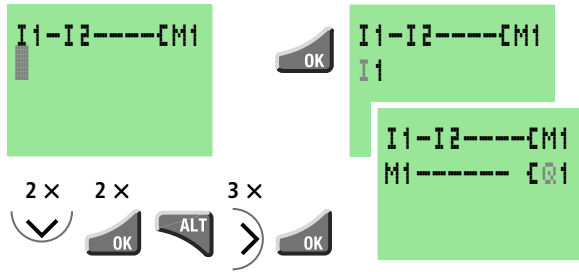

### Select Trigger relay for time

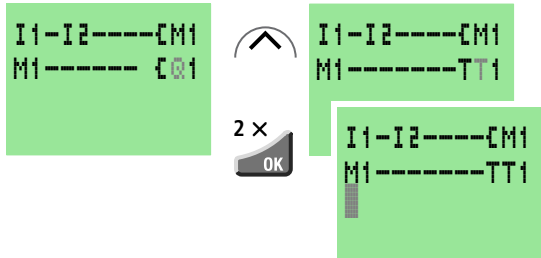

### Insert timing relay contact

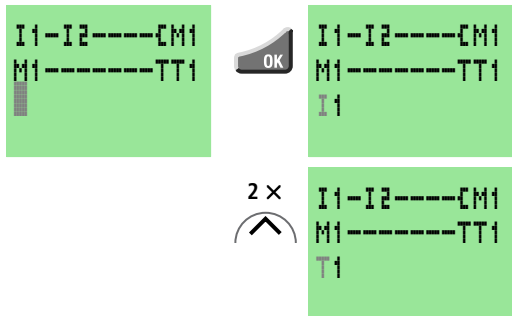

### Select parameter access

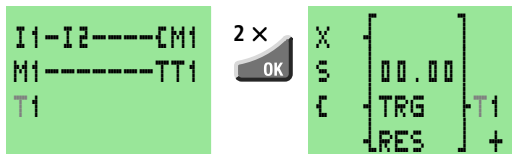

### Set “10 seconds”

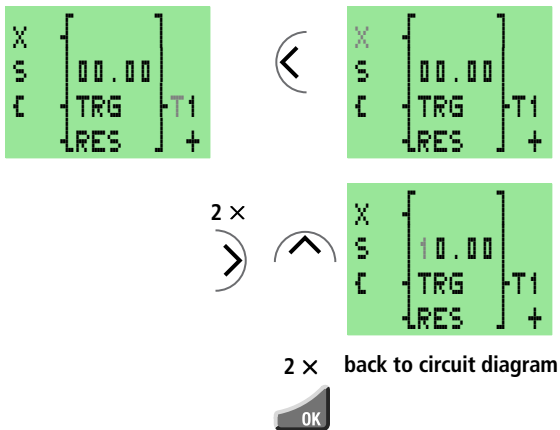

### Connect timing relay contact to new output relay

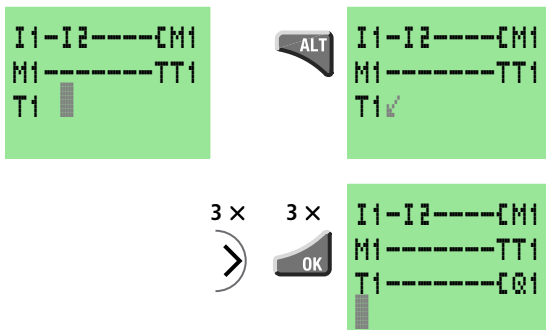

Switch “easy” to RUN to test circuit diagram.

- ▶ Test the circuit as shown for the first example.

To display and access the parameters for the timing relay and change the time value:

- ▶ In RUN mode, position the cursor in the circuit diagram on the “T” of “T1” and press **OK**.

**Basic circuits**

## Significance of logic values

- “0” Make contact open, break contact closed, relay coil not energised
- “1” Make contact closed, break contact open, relay coil energised

**Negation (NOR)**

I1	Q1
1	0
0	1

**Permanent contact**

---	Q1
1	1

**Impulse relay**

I1	State Q1	Q1
0	0	0
1	0	1
0	1	1
1	1	0

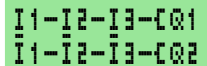

**Series connection (AND)**

I1	I2	I3	Q1	Q2
0	0	0	0	1
1	0	0	0	0
0	1	0	0	0
1	1	0	0	0
0	0	1	0	0
1	0	1	0	0
0	1	1	0	0
1	1	1	1	0

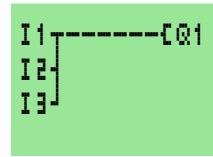

### Parallel connection (OR)

I1	I2	I3	Q1	Q2
0	0	0	0	1
1	0	0	1	1
0	1	0	1	1
1	1	0	1	1
0	0	1	1	1
1	0	1	1	1
0	1	1	1	1
1	1	1	1	0



### Changeover circuit (XOR)

I1	I2	Q1
0	0	0
1	0	1
0	1	1
1	1	0

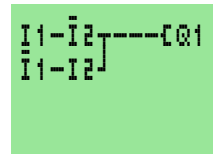

### Latching circuit

I1	I2	Contact Q1	Coil Q1
0	0	0	0
1	0	0	0
0	1	0	0
1	1	0	1
1	0	1	0
0	1	1	1
1	1	1	1

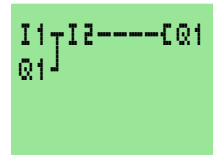

alternatively:

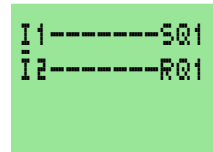

### 3 “easy” Interface Socket

The “easy” interface socket, which is hidden beneath a protective cap, lets you plug in the optional “easy” memory card or connect “easy” to a PC using the optional PC interface cable and the EASY-SOFT software. You can then copy your circuit diagrams to and from the PC and/or memory card. In addition you can draw and test your circuit diagrams on the PC before transferring them to “easy”.

#### Memory card

Memory cards are available as the optional accessory “easy-M-..K”. Each memory card can store a single “easy” circuit diagram.

Information stored on the memory card is “non-volatile” (the information is not lost when the power is switched off), and thus you can use the card to make a backup copy of your circuit diagram and/or to transfer it to another “easy” device.

Each memory card stores:

- the circuit diagram
- all parameter settings of the circuit diagram
- system settings

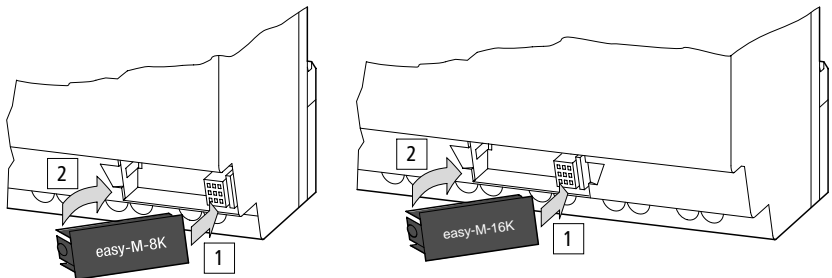

### Loading or storing the circuit diagram

You can only transfer the circuit diagram from “easy” to the card or vice versa in STOP mode.

“EASY->CARD”: Transfer circuit diagram and parameter settings from “easy” memory to the card,



“CARD->EASY”: Transfer circuit diagram and parameter settings from the card to “easy” memory,

“DELETE CARD”: Delete the contents of the card.

### Available memory cards

EASY-M-8K memory card for EASY 412-...

EASY-M-16K memory card for EASY 618/620-...

### EASY-SOFT

EASY-SOFT is an optional PC program with which you can create, store, test (simulate) and manage “easy” circuit diagrams. You can then transfer the circuit diagrams from the PC to “easy” or vice versa using a special PC interface cable.

You should only transfer the circuit diagrams using the special PC interface cable, which is available as the optional accessory “easy-PC-CAB”.

To test your circuit diagram in the “easy” device itself, transfer it from the PC to “easy” and choose RUN mode by pressing the appropriate buttons.

The EASY-SOFT software also includes extensive online Help.

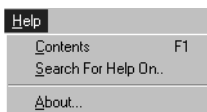

To use the online Help, start EASY-SOFT and choose Contents in the Help menu.

Context sensitive help is also available choose a menu item with the mouse and press F1 while keeping the mouse button pressed.

## 4 Technical Data

### Technical data

Weight	200 g, 300 g (EASY 600)
Ambient temperature, (operation)	-25 to 55 °C
Protection class	IP 20
Emitted interference, interference immunity	EN 55 011, EN 55 022, Class B
Standards and regulations Approvals	EN 50 178 UL, CSA

### “easy” models

	EASY 412-DC-...				EASY 412-AC-...			EASY 618-...	EASY 620-...
	...R	...RC	...TC	...TCX	...R	...RC	...RCX	...AC-RC	...DC-TC
Power supply	24 V DC power feed				115, 230, 240 V AC			100, 115, 120, 230, 240 V AC	24 V DC power feed
Digital inputs	8 digital inputs, 2 of them also usable for analog signals				8	8	8	12	12 digital inputs, 2 of them also usable for analog signals
Relay outputs	4	4	–	–	4	4	4	6	–
Transistor outputs	–	–	4	4	–	–	–	–	8
LCD display	✓	✓	✓	–	✓	✓	–	✓	✓
Operating buttons	✓	✓	✓	–	✓	✓	–	✓	✓
Time switch	–	✓	✓	✓	–	✓	✓	✓	✓
Text display	–	–	–	–	–	–	–	✓	✓
Retentive actual values	From version V 1.2				–	–	–	✓	✓

### Accessories

Software	EASY-SOFT, Version 2.0, for Windows 95/98, Windows NT	
PC – “easy” interface cable	EASY-PC-CAB with interface electronic circuit	
Memory card	EASY-M-8K	EASY-M-16K



## Technical Data

	EASY 412-DC-...				EASY 412-AC-...			EASY 618-...	EASY 620-...
	...R	...RC	...TC	...TCX	...R	...RC	...RCX	...AC-RC	...DC-TC
Input/output simulator	EASY 412-DC-SIM				-	-	-	-	-
Mounting feet	ZB 4-101-GF1: For EASY 412-... 3 feet							min. 3	
Documentation	Training Guide (AWB 2528-1316 GB), User Guide (AWB 2528-1304 GB), Application Guide (TB 2528-025 GB)								

### Dimensions EASY 412-...

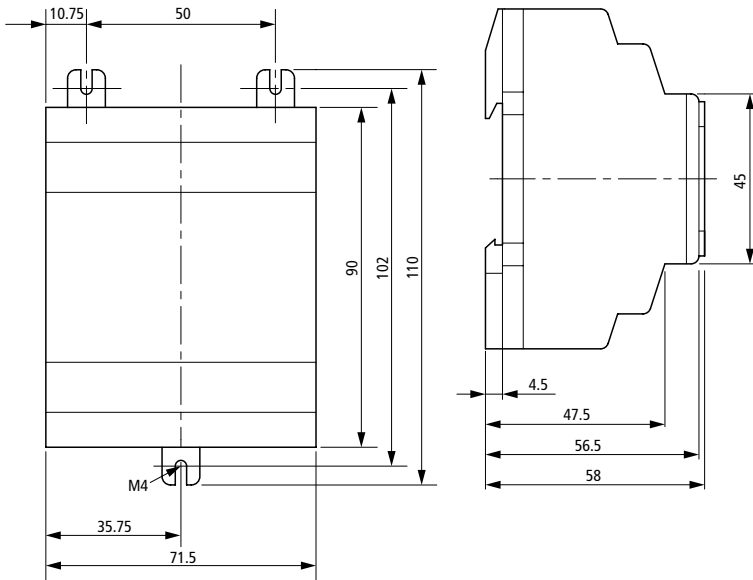

“easy” models

### Dimensions EASY 618-..., EASY 620

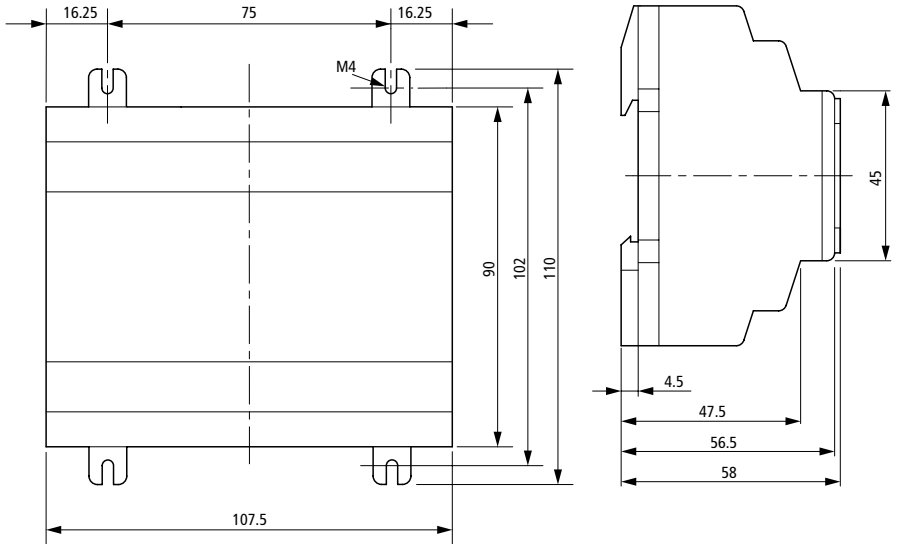



# Index

## A

Accessories .....	45
Accuracy	
Analog comparator .....	35
Analog comparator .....	35
Hysteresis .....	35
AND circuit .....	41

## B

Basic circuit	
Impulse relay .....	41
Parallel connection .....	42
Permanent contact .....	41
Basic circuits	
Example .....	41
Break contact .....	23
Buttons .....	11
Use in circuit diagrams .....	19

## C

Change operating mode .....	22
Changeover circuit .....	42
Circuit diagram	
Access relay parameters .....	39
Choosing relay type .....	27
Displaying .....	26
Example .....	26, 37
Inserting contacts .....	26
Loading .....	44
Select marker relay .....	37
Storing .....	44
Symbols .....	14
Testing .....	28
Using a function relay .....	37
Using buttons in .....	19
Circuit diagram elements .....	23
Coil function .....	25
Connecting inputs .....	6
Connecting outputs .....	6

Contactor function .....	25
Contacts	
Overview .....	23
Counter relay .....	33
Parameter display .....	33
Cursor display .....	13
<b>D</b>	
Dimensions, “easy” .....	46
<b>E</b>	
Overview of “easy” .....	5
Example	
Basic circuits .....	41
Circuit diagram .....	26
Contacts and relays .....	26
Example of function relay .....	37
<b>F</b>	
Function relay	
Analog comparator .....	35
Function relays	
Counter relay .....	33
Overview .....	30
Time switch .....	34
Timing relay .....	30
<b>H</b>	
Hysteresis	
Analog comparator .....	35
<b>I</b>	
Impulse relay .....	25
<b>L</b>	
Language for menus	
Changing .....	20
Latching circuit .....	42
Latching relay .....	25
Logic tables .....	41–42

<b>M</b>	
Make contact .....	23
Marker .....	36
Memory card (optional) .....	43
Menu guidance .....	11
Menu language	
Changing .....	20
Menu structure .....	15
Models .....	45
Mounting .....	6
<b>N</b>	
Negation .....	41
NOT .....	41
<b>O</b>	
Operating buttons .....	11
OR circuit .....	42
<b>P</b>	
Parameter display	
Analog comparator .....	35
Counter relay .....	33
For timing relays .....	32
Time switch .....	34
<b>R</b>	
Relay	
Impulse .....	25
Latching .....	25
Relay types	
Overview .....	24
Reset input .....	25
<b>S</b>	
Series connection .....	41
Set input .....	25
Setting the time .....	21
Setting week days .....	21
Startup behaviour .....	22
Status display .....	12
Summer time .....	22

Symbols in circuit diagram ..... 14  
System menu ..... 16

**T**  
Terminals, inputs/outputs ..... 6  
Text display ..... 36  
Time switch ..... 34  
    Parameter display ..... 34  
Timing relays ..... 30–32  
    Parameter display ..... 32  
Transfer cable ..... 43

**W**  
Winter time ..... 22

**X**  
XOR circuit ..... 42