

XX214-00-06

Surveyor® HD/SD Series Network Camera Domes



Vicon Industries Inc.

**Tel: 631-952-2288 Fax: 631-951-2288 Toll Free: 800-645-9116
24-Hour Technical Support: 800-34-VICON (800-348-4266) UK: 44/(0) 1489-566300**

Vicon Industries Inc. does not warrant that the functions contained in this equipment will meet your requirements or that the operation will be entirely error free or perform precisely as described in the documentation. This system has not been designed to be used in life-critical situations and must not be used for this purpose.

www.vicon-security.com

FCC Notice

Note: Complies with Federal Communications Commission Rules & Regulations Part 15, Subpart B for a Class A digital device.

WARNING

This equipment generates and uses radio frequency energy and if not installed and used properly, that is, in strict accordance with the manufacturer's instruction, may cause interference to radio and television reception. It has been type tested and found to comply with the limits for a Class A computing device in accordance with the specification in subpart B of part 15 of the FCC rules, which are designed to provide reasonable protection against such interference in a commercial installation. However, there is no guarantee that interference will not occur in a particular installation. If this equipment does cause interference to radio and television reception, which can be determined by turning equipment off and on, the user is encouraged to try and correct the interference by one or more of the following measures:

- Reorient the receiving antenna.
- Relocate the equipment with respect to the receiver.
- Relocate the equipment away from the receiver.
- Plug the equipment into a different electrical outlet so that the equipment and receiver are on different branch circuits.

If necessary, the user should consult the dealer or an experienced radio/television technician for additional suggestions.

The user may find the following booklet prepared by the Federal Communications Commission helpful:

"Interference Handbook, Bulletin CIB-2"

This booklet is available from the U.S. Government Printing Office, Superintendent of Documents, Mailstop SSOP, Washington, D.C. 20402-9328, ISBN 0-16-045542-1.

⚠ Warning: *Power must be removed from this unit before removing circuit modules or cables.*

⚠ Caution: *This unit contains circuit cards with integrated circuit devices that can be damaged by static discharge. Take all necessary precautions to prevent static discharge.*

Important Safeguards – Outdoor Use

GRAPHIC SYMBOL EXPLANATION

The lightning bolt symbol alerts the user to the presence of dangerous voltage that may present the risk of electric shock.

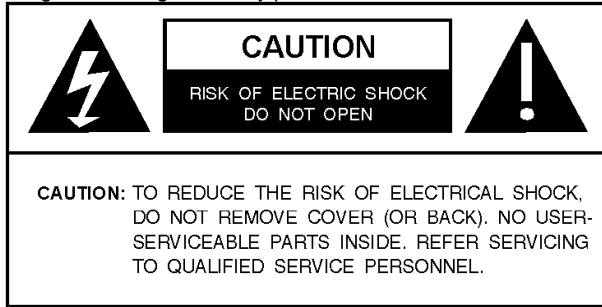

The exclamation point symbol alerts the user to the presence of important operating and maintenance instructions.

1. **Read Instructions** - Read all safety and operating instructions before the product is operated.
2. **Retain Instructions** - Retain all safety and operating instructions for future reference.
3. **Heed Warnings** - Pay attention to all product warnings.
4. **Follow Instructions** - Follow all operating instructions.
5. **Installation and Wiring** - The equipment shall be installed and wired in accordance with the National Electrical Code, ANSI/NFPA 70.
6. **Cleaning - (Do not use caustic, abrasive or aerosol cleaners)**
 - a) For units that CAN BE DISCONNECTED from the power source, use a damp cloth for cleaning.
 - b) For units that CANNOT BE DISCONNECTED from the power source, use a damp cloth for cleaning and do not allow moisture or liquids to enter vents.
7. **Attachments** - Use only UL Listed Vicon recommended attachments to prevent unit damage and personal injury.
8. **Water and Moisture** - Use only products designed for outdoor environments where they will be exposed to water or moisture.
9. **Accessories** - Do not place the unit on an unstable surface to avoid falling. Use only UL Listed Vicon recommended mounting accessories.
10. **Ventilation** - Do not block ventilating slots and openings as they ensure reliable operation. Do not place the unit near a heat source or into an enclosure unless recommended by Vicon.
11. **Power Sources** - The product should only be operated from the recommended power source. Use only a UL Class 2 indoor/dry or Class 3 outdoor/wet power supply.
12. **Grounding** - Only products equipped with a 3-prong grounded plug should be inserted into a grounded power outlet. Contact an electrician to replace an obsolete outlet. Do not force a plug into a non-grounded outlet.
13. **Power Cord Protection** - Power supply cords should not be routed in trafficked areas or in tight spaces where they will be pinched or used to bear weight. Allow some slack in the cord where it enters the unit.
14. **Outdoor Cable Grounding** - Use only grounded outdoor cables to protect against voltage surges and static charges. Section 810 of the National Electrical Code, ANSI/NFPA 70-1984,

provides information on proper grounding of the lead-in wire to an antenna discharge unit, size of grounding conductors and the requirements of grounding electrodes.

15. **Lightning** - Disconnect the product from its power source and cable system when possible to prevent damage due to lightning and power-line surges.
16. **Power Lines** - Do not locate outside cables over power or utility lines where they can fall and make direct contact. Contact with power lines can be fatal.
17. **Overloading** - Do not overload wall outlets and extension cords to prevent risk of fire and electric shock.
18. **Object and Liquid Entry** - Never probe through, or spill liquid into, enclosure openings to prevent risk of fire or electric shock.
19. **Servicing** - Refer all servicing to qualified service personnel.
20. **Damage Requiring Service** - Obtain service when:
 - a) The power-supply cord or plug is damaged.
 - b) Objects have fallen or liquid has been spilled into the product.
 - c) The product is not designed for outdoor use and has been exposed to water or moisture.
 - d) The product does not operate per the operating instructions. Perform Vicon recommended adjustments, modifications and troubleshooting only to avoid unit damage and personal injury.
 - e) The product has been dropped.
 - f) The product shows a significant change in performance.
21. **Replacement Parts** - Use only Vicon specified replacement parts or an approved equivalent to prevent unit damage and injury.
22. **Safety Check** - Request safety checks to be performed following repair or maintenance to verify proper operation.
23. **ESD Precaution** - Take all normal electrostatic discharge precautions to avoid component damage during installation and operation.
24. **For 230 VAC Devices Only** - When the disconnect device is not incorporated in the equipment or when the plug on the power supply is intended to serve as the disconnect device, follow the guidelines below:
 - a) For permanently connected 230 VAC units, a readily accessible disconnect device must be incorporated into the site wiring.
 - b) For 230 VAC units with a plug, the outlet must be installed near the unit and be easily accessible.
25. **Lithium Batteries Only:**

WARNING

Fire and burn hazard. Do not recharge, disassemble, heat above 212°F or incinerate. Keep battery out of reach of children and in original package until ready to use. Dispose of used batteries promptly.

Risk of explosion if battery is replaced by incorrect type. Dispose of used batteries according to the instructions.

Chapter 1

Introduction

1

This chapter provides general information about the Surveyor® HD and Surveyor SD Network Domes. Refer to the end of this chapter for the organization of the rest of this manual.

The chapter consists of the following topics:

Topic	Page
General Information	1-2
Model Tables	1-3
Organization of this Manual	1-4

General Information

The information in this manual covers the installation and operation of the Surveyor HD and Surveyor SD (Surveyor HD/SD) Network Dome.

Note

Read all instructions before beginning any installation.

The Surveyor HD/SD is a compact network dome comprised of a camera/lens and pan/tilt drive in an attractive covert enclosure. Surveyor HD/SD is sold in a variety of prepackaged configurations with choices in environment, mounting configuration, and lower dome types. Refer to Table 1 for a complete list of model numbers. The term Surveyor HD/SD refers to all domes in this series unless specifically stated otherwise.

The Surveyor HD/SD provides network video transmission using high-profile H.264 or M-JPEG compression. The dome supports ONVIF Profile S open architecture connectivity to enable integration into third party Video Management Systems (VMS), including Vicon's ViconNet.

The Surveyor HD/SD is designed for easy installation and serviceability. The entire drive assembly simply snaps into the housing. When removed, the mechanism retains all programmed functions in its on-board memory. The customer interface board snaps down for easy access and the PCB provides removable terminal blocks for simple wiring connections. The camera dome offers variable speed with stepping motors, continuous rotation and preset positions. Power to the indoor units can be provided by PoE+ (Power over Ethernet Plus). Additionally, two fiber versions, multi-mode and single-mode, and a version for NTCIP are available.

The Surveyor HD includes a high-definition 1.3 or 2.0 megapixel day/night camera with wide dynamic range (WDR) and digital noise reduction (DNR/FNR). The Surveyor SD includes a day/night camera with 540 TV line resolution. See Technical Information for camera features. Camera image settings are configured via a user-friendly web browser interface.

All versions use the same firmware for programming and operation. For programming, refer to the most recent version of Surveyor HD/SD Programming Manual XX214-40. The Surveyor HD/SD Network Dome is compatible with the SVFT-UWM and SVFT-WM Wall Mounts, SVFT-UCM Ceiling Mount, SVFT-IC-KT In-Ceiling Mount, SVFT-UCP Ceiling Panel, SVFT-URM-1 Roof Mount, and SVFT-UPM-1 Parapet Mount.

Surveyor HD/SD meets requirements for an FCC Class A computing device and is UL and CE compliant. Surveyor HD/SD complies with the fire code of certain local municipalities. The fire code for any given municipality should be verified for Surveyor HD/SD's compliance at the installation site.

The electronic components within the Surveyor HD/SD are sensitive to damage from ESD (Electro-Static Discharge). Appropriate precautions and proper use of a ground strap should be observed at all times when handling the unit or its subassemblies.

Table 1: Models and Descriptions

Model Number*	Environment	Resolution	Mount Type	Optical Zoom	Lower Dome Type
SN130C	Indoor	1.3 megapixel	In-Ceiling	30X	Smoked
SN130D	Indoor	1.3 megapixel	Pendant	30X	Smoked
SN130W	Outdoor	1.3 megapixel	Pendant	30X	Clear
SN130M	High-Impact Outdoor	1.3 megapixel	Pendant	30X	Clear
SN220C-L	Indoor	2.0 megapixel	In-Ceiling	20X	Smoked
SN220D-L	Indoor	2.0 megapixel	Pendant	20X	Smoked
SN220W-L	Outdoor	2.0 megapixel	Pendant	20X	Clear
SN220M-L	High-Impact Outdoor	2.0 megapixel	Pendant	20X	Clear
SN036C	Indoor	540 TV lines	In-Ceiling	36X	Smoked
SN036D	Indoor	540 TV lines	Pendant	36X	Smoked
SN036W	Outdoor	540 TV lines	Pendant	36X	Clear
SN036M	High-Impact Outdoor	540 TV lines	Pendant	36X	Clear

*Add a –FM to the model number for a multi-mode fiber version and a –FS to the model number for a single mode fiber model.

Table 2: Power Table

Model Number	Power (W)	Current Rating (A) (see notes)
SN130C, SN130C-FM, SN130C-FS	20	1.0 (1)
SN130D, SN130D-FM, SN130D-FS	20	1.0 (1)
SN130W, SN130W-FM, SN130W-FS	70	2.2 (2)
SN130M, SN130M-FM, SN130M-FS	70	2.2 (2)
SN220C-L, SN220C-L -FM SN220C-L -FS	20	1.0 (1)
SN220D-L, SN220D-L- FM, SN220D-FS	20	1.0 (1)
SN220W-L, SN220W-L-FM, SN220W-L-FS	70	2.2 (2)
SN220M-L, SN220M-L-FM, SN220M-L-FS	70	2.2 (2)
SN036C, SN036C-FM, SN036C-FS	20	1.0 (1)
SN036D, SN036D-FM, SN036D-FS	20	1.0 (1)
SN036W, SN036W-FM, SN036W-FS	70	2.2 (2)
SN036M, SN036M-FM, SN036M-FS	70	2.2 (2)

Notes:

- (1) – Max. current at low line
- (2) – Max current at high line

Organization of this Manual

Chapter	Description
1	Introduction: Provides general information about the Surveyor HD/SD Network Dome
2	Installation: Describes how to install the Surveyor HD Network Dome
3	Wiring and Operation: Describes how to wire, configure and operate the Surveyor HD/SD Network Dome
4	Maintenance and Reference: Describes basic system maintenance, reference information, shipping instructions and technical specifications for the camera dome.

Note

Always check the Vicon website, www.vicon-security.com, for the latest updated manuals.

Chapter 2 Installation

2

This chapter provides installation information for the Surveyor HD/SD Network Dome.

The chapter consists of the following topics:

Topic	Page
Installation	2-2
Quick Installation	2-7
Detailed Installation	2-8

Installation

Caution

This unit should only be installed by a qualified technician using common hand tools and approved materials and wiring methods in accordance with the National Electrical Code ANSI/NFPA 70, state and local wiring codes. All interconnecting equipment or accessories must be UL Listed. Any mention in this manual of alarm inputs/outputs have not been evaluated by UL to be used for burglar alarm functionality.

How to Use this Manual

This manual was designed to provide the best overall instructions for the installation and operation of the Surveyor HD/SD Network Dome. The graphics and terminology used in this manual have been carefully selected to enable a clear and distinct understanding of the Surveyor HD/SD and its components. This manual has been formatted to present distinct methods of installation for qualified service personnel only.

For a quick overview of product installation, see the Quick Installation subsection of the Installation section and choose the appropriate method (In-Ceiling Mount Model, Indoor/Outdoor/High-Impact Pendant Model) to begin. Follow the references provided in the text for items such as wiring tables and lower dome care. Refer to the subsequent sections of Installation, Wiring, Configuration and Operation for detailed descriptions of any method.

Accessory Kits

There are different accessory kits included with the different configurations of Surveyor HD/SD; these kits provide the necessary items for installation as follows:

Description	Quantity
2-position terminal block	1
4-position terminal block	1
8-position terminal block	1

Note

A scribe and a strain relief are included in the in-ceiling unit accessory kit only. A packet of anti-seize lubricant is included with the outdoor pendant and high-impact models; the high-impact version also includes a bit that fits the tamperproof screws.

Refer to the Wiring section of this manual for details on using the supplied removable termination blocks. The scribe is supplied to accurately measure the opening for the in-ceiling model. The lubricant is used for sealing and to prevent galling at the end of the 1.5-inch NPT pipe on the outdoor pendant model. Refer to the outdoor pendant model sub-section of the Installation section for details on applying the lubricant.

Unpacking

All Vicon equipment is tested and inspected before leaving the factory. It is the carrier's responsibility to provide suitable delivery.

Inspect the cartons upon delivery and, if damage is present, make detailed notes on the carrier's bill. Then, obtain the carrier agent's signature and file a damage claim as soon as possible.

Open the cartons and inspect the equipment for damage. Save the cartons and packing material. If damage is present, contact the carrier and file a damage claim immediately. If the equipment must be returned for repair, follow the instructions in the Shipping Information section of this manual.

Remove the Accessory Kit and the unit from the box. Open the Accessory Kit and verify the hardware contained in the kit against the preceding table.

Components

All Surveyor HD/SD units are comprised of an Enclosure/Housing, a Camera Drive, a Shroud and a Lower Dome.

Enclosure

The enclosure is a metal shell that houses the camera drive for the in-ceiling model. A safety cord and clip are provided to connect to the camera drive during installation. In addition, a small hole is provided on the side of the enclosure for connection of the lower dome's safety cord. A removable top cover, a 0.75-inch (19 mm) conduit fitting and a pair of rotating flippers that give a convenient and sturdy connection of the enclosure into the ceiling are provided. For in-ceiling installations that do not use conduit pipe, a 0.75-inch (19 mm) strain relief fitting provides solid cable anchoring at the enclosure. A customer interface board, that can be unlatched or removed for easy access, is installed in the top of the enclosure. All wiring is done to this board.

Housing

The housing for the Surveyor HD/SD indoor pendant configurations is a molded plastic protective cover for the camera drive; outdoor pendant configurations have a die-cast aluminum housing with a sunshield. The housing has a 1.5-inch NPT pipe flange mount. In addition, the housing is equipped with a safety cord and clip that is used to suspend the camera drive during installation. Another safety cord connects the lower dome to the housing. A customer interface board, that can be unlatched or removed for easy access, is installed in the top of the enclosure. All wiring is done to this board.

Camera Drive

The camera drive is comprised of an integral camera, pan-and-tilt drive and CPU. It is designed for easy "snap-in" installation into the enclosure or housing. The camera drive quickly and accurately positions the camera in 360° of pan angle and 95° of tilt angle. An additional processor-controlled heater is provided for temperature control on outdoor units.

Shroud

The shroud is a 5.4 in. (137 mm) textured black ABS plastic shell. It has a 1.4 in. (35.6 mm) slotted opening for the camera. This shroud conceals the position of the camera and snaps onto the camera drive.

Lower Dome

The lower dome is an assembly comprised of a 5.98 inch (152 mm) diameter acrylic plastic shell, a trim ring and a safety cord. Lower domes for indoor versions come are smoked; chrome or gold finishes are available as special

options. Standard outdoor lower domes are clear and use 4 screws for additional support. All lower domes are anchored to the enclosure by the safety cord. Refer to the Maintenance section for care.

Sunshield

The sunshield is pre-installed over the housing used on the outdoor/ high-impact pendant version to minimize the effects of solar radiation.

Caution

For any environment subject to moisture, use the outdoor pendant model.

MAC Address

IMPORTANT NOTE!

Each IP camera board has a unique MAC (media access control) address. This information is essential in the camera configuration process. Before starting installation, make a record of this address and the location where the dome is installed. The MAC address label is located as shown in the illustration below. There will also be a sticker with the CD that will include the MAC address and password for that specific camera (the password can be a combination of numbers and letters up to 8 characters long).

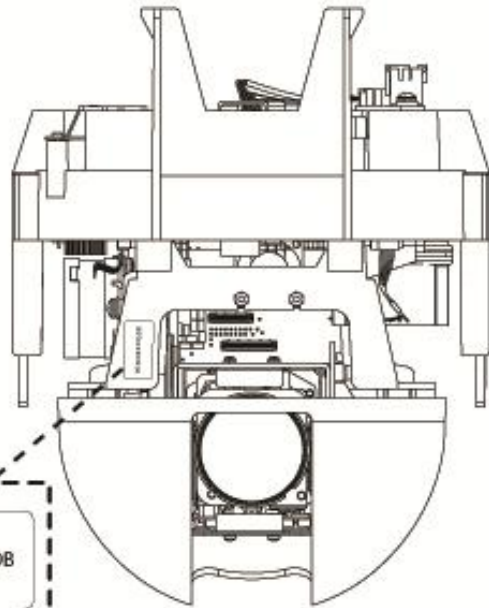

00:06:68:02:55:DB

Make all entries to the log below and retain for future reference

MAC Address	Password	Camera Location
Example: 00-06-68-19-00-79	4765D274	<i>first floor- lobby doors</i>

Quick Installation

Choose the installation type based on the specific unit purchased (In-Ceiling, Indoor or Outdoor/High-Impact Pendant).

In-Ceiling Installation

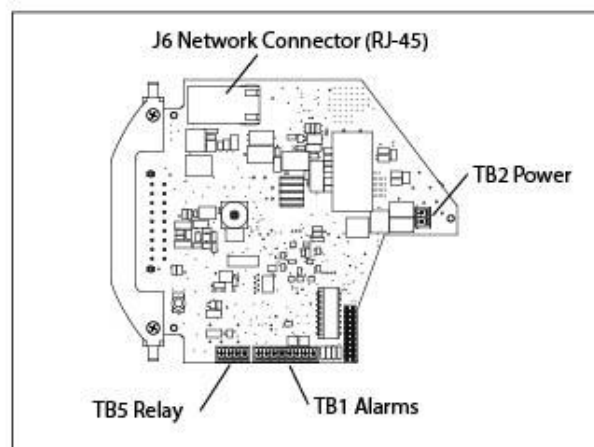
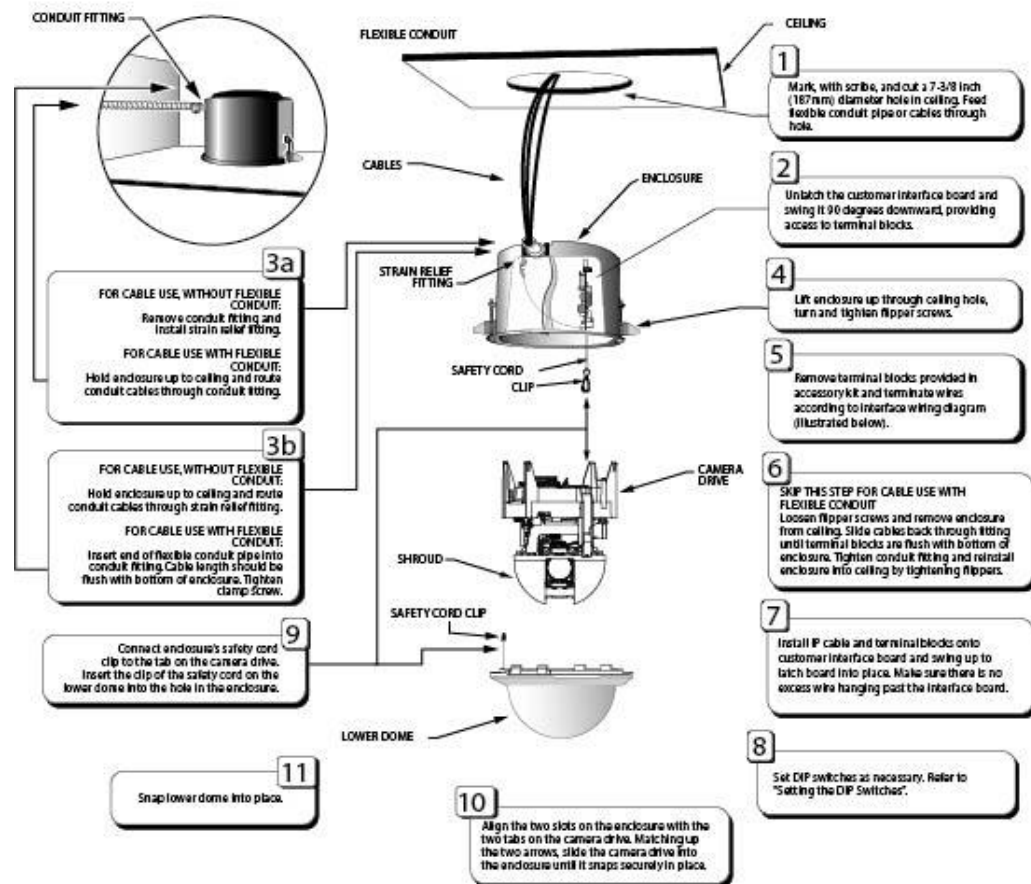

Pendant Installation

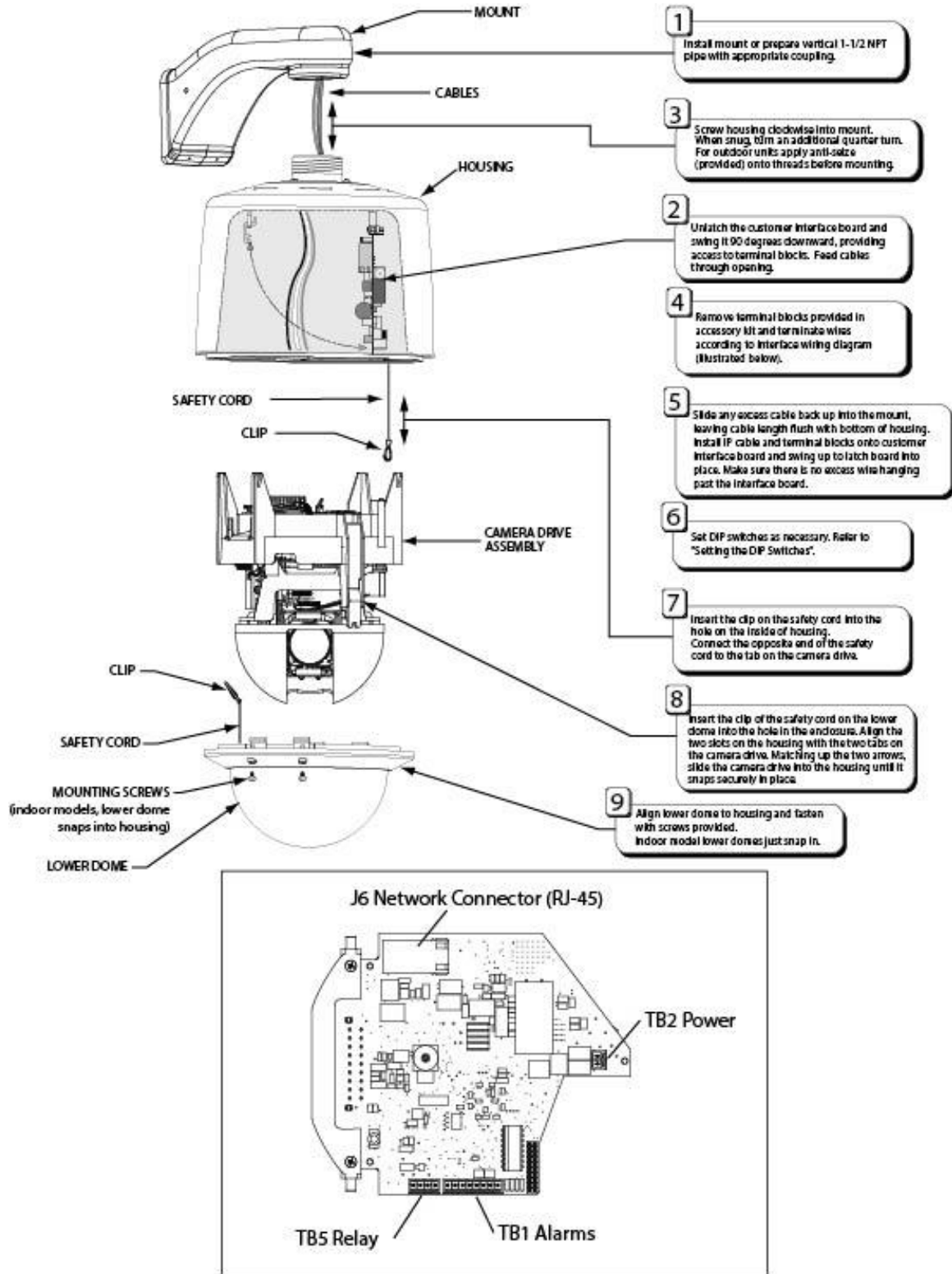

Detailed Installation

Select a location for the installation of the Surveyor HD/SD. Be sure the area around the selected location is clear of obstacles (such as steel beams, headers, pipes, electrical wiring, etc.) that could interfere with the mounting of the camera dome and that the location can support the weight of the unit. All cables must be routed to the installation location. Be sure to set the DIP switches before completing installation; refer to DIP switch setting section in Wiring chapter.

In-Ceiling Model

This version of Surveyor HD/SD mounts in the ceiling and rests on the ceiling material occupying the space between the lower ceiling and upper building frame. All mounting hardware is provided.

Use of the Provided Scribe

A small metal scribe is provided to assist in marking an accurate hole size in a ceiling tile for in-ceiling installations. Use as follows:

1. Place one end of the scribe in the center position of the desired location for the dome installation. If using a ceiling tile, remove it and place it on a large flat surface, face up. Refer to figure below.
2. Rotate the scribe around for a full turn.
3. Cut out the circle, using a sharp tool, on the scribed line.

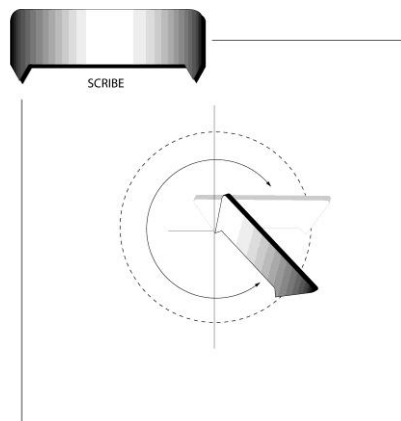

The accessory kit contains the removable screw terminal blocks to be used for all connections in this installation.

The ceiling material must provide a surface of suitable strength for the Surveyor HD/SD weight of 4.6 lb (2.1 kg) on the area of the two flippers. Refer to the *Optional Independent Support* sub-section for installations requiring additional support.

1. Mark, with the scribe, and cut a 7-3/8-inch (187 mm) diameter hole in ceiling at the desired location. Feed all flexible conduit pipe or cables down through the hole.
2. Unlatch the customer interface board and swing it 90° downward, providing access to terminal blocks. Refer to Figure below. (The board can be completely removed, if necessary, by snapping it out of the hinge after rotated to the 90° downward position.)

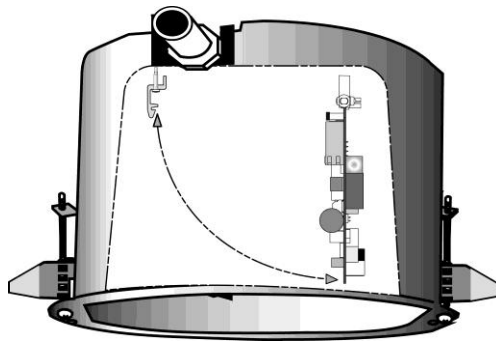

3. If cables are used without the use of flexible conduit:
 - a) Remove the conduit fitting by loosening the nut and sliding it out. Install the supplied strain relief fitting in its place.
 - b) Hold the enclosure near the hole in the ceiling and route cables through the strain relief fitting.
4. If cables are channeled through flexible conduit:
 - a) Hold the enclosure near the hole in the ceiling and route conduit cables through the conduit fitting.
 - b) Insert the end of the flexible conduit pipe into the conduit fitting. Cable length should be flush with the bottom of enclosure, approximately 9 inches (229 mm). Tighten the clamp screw.
5. Lift enclosure up through ceiling hole, turn and tighten flipper screws.
6. Remove terminal blocks from the accessory kit. The 2-pin (TB2) is for power, the 4-pin (TB5) is for control/relay and the 8-pin (TB1) is for alarms.

Note

There should be minimal wire slack at all connection points.

Skip step 6 for cable use with flexible conduit.

7. Loosen flipper screws and remove enclosure from ceiling. Slide cables back through fitting until terminal blocks are flush with the bottom of enclosure, approximately 9 inches (229 mm). Tighten conduit fitting and reinstall enclosure into ceiling by tightening flippers.
8. Install the terminal blocks TB2, TB5 and TB1 into the Customer Interface Board at the proper block frames. Refer to the **Installing the Cables** sub-section of the Wiring section and Table 2 for detailed instructions on wiring the unit. Swing up interface board to latch board into place. If interface board was completely removed, be sure to reinstall it correctly, with the white connector near the wall of the enclosure. Dress cables up over board to ensure there is no excess cable hanging past the board.
9. Configure the Surveyor HD/SD DIP switches on the main board at this time. See Setting the DIP Switch section of this manual.
10. Connect the enclosure's safety cord clip to the tab in the camera drive to allow the drive to hang from the enclosure. Refer to Figure below for location of tab. Insert the clip of the safety cord on the lower dome into the hole in the enclosure. Refer to label in the enclosure.

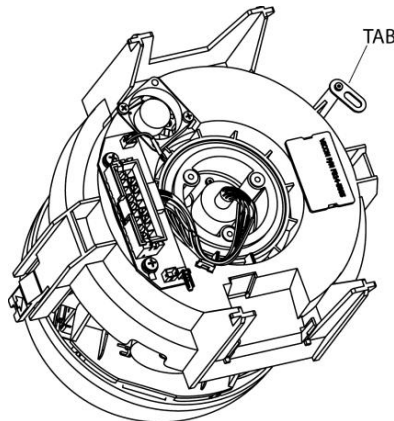

11. Align the 2 slots on the camera drive with the tabs in the enclosure, being sure to match up the arrows on both the drive and in the enclosure. Insert the camera drive into the enclosure until it snaps into place.
12. Lift the lower dome up to the Surveyor HD/SD and line up the 2 molded tabs on the lower dome with the 2 recesses on the inner enclosure. There are only 2 ways to align it.

13. Push the lower dome up into the Surveyor HD/SD. Verify that it snaps into place on both sides. The upper edge of the lower dome should be flush with ceiling plane. Refer to figure below.

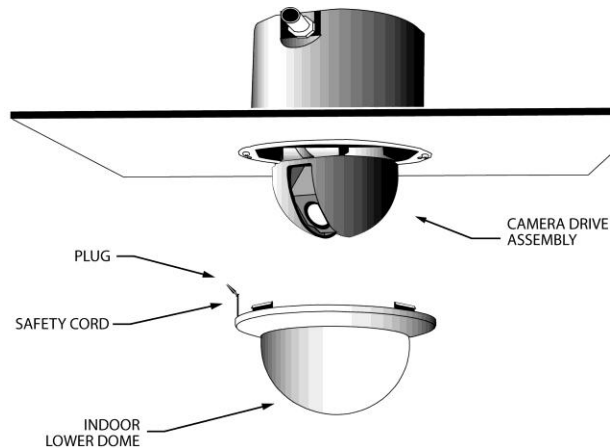

14. Proceed to the Operation section of this manual.

Optional Independent Support

If it is necessary to provide independent support for the Surveyor HD/SD, other than the ceiling material, order the optional In-Ceiling Mount Kit, SVFT-IC-KT. It consists of a pre-assembled set of mounting rails and folding ring. Refer to Figure below.

1. With the 7-3/8-inch (187 mm) diameter hole cut in the ceiling tile and tile replaced in the ceiling, push the folded assembly up through the hole and unfold.
2. Position the assembly squarely over the hole and fasten the caddy rail clips to the existing frame. Remove adjacent tiles to access the clips.
3. Adjust the position of the caddy rail clips along the frame to obtain the best position.
4. Slide the assembly along the caddy rails to obtain the best concentric horizontal position. Tighten the horizontal adjustment screws to secure the position.
5. With the ring concentric with the hole, slide the ring vertically along the support slots to obtain the best flush fit in the ceiling. The ring should be firmly seated against the tile without warping the tile.
6. Finally, complete the installation as described in the procedure of the previous sub-sections. In this installation, the flippers will secure the enclosure to the mounting ring assembly instead of the tile.

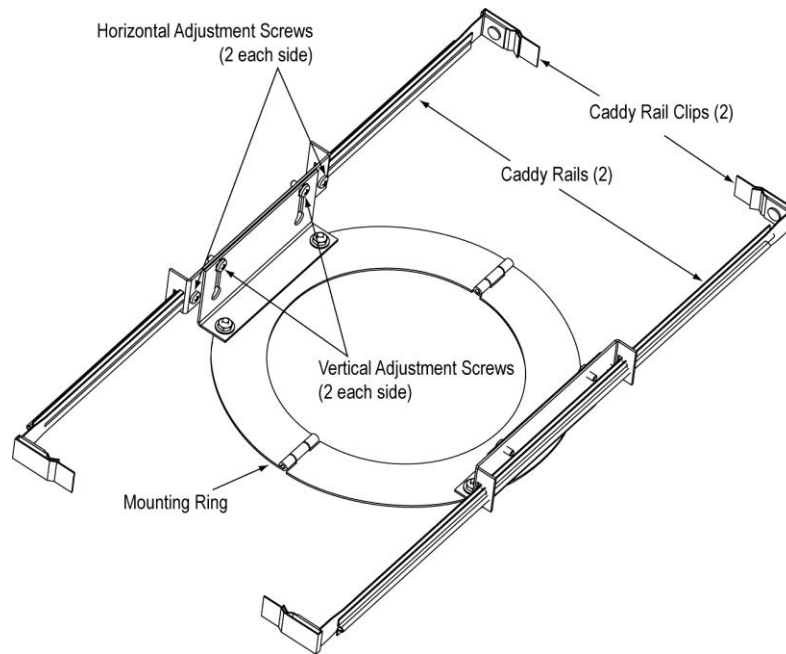

Pendant Mount Models

The indoor, outdoor and high-impact pendant models mount on a variety of Vicon mounts or a 1.5-inch vertical pipe with an appropriate coupling. The pipe is a standard 1.5-inch NPT type and must be oriented vertically so the Surveyor HD/SD can effectively hang from the pipe.

The accessory kit contains the removable terminal blocks for all connections in this installation. The mount must provide a support of suitable strength for the indoor pendant Surveyor HD/SD weight of 4.2 lb (1.9 kg) or the outdoor/high-impact pendant Surveyor HD/SD weight of 7.2 lb (3.3 kg), which includes a sunshield.

1. Install the mount in accordance with the installation manual included with the mount or prepare the vertical 1.5-inch NPT pipe.
2. Feed all necessary cables through the back of the mount or out the end of the 1.5-inch NPT pipe.
3. Unlatch and rotate the customer interface board 90° downward to provide access to the terminal blocks. (The board can be completely removed if necessary by snapping it out of the hinge after rotated to the 90° downward position.) Refer to figure below.

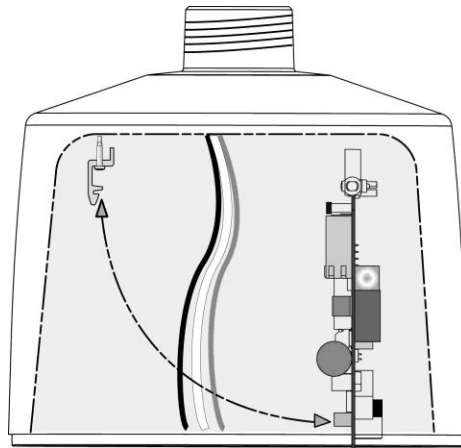

4. On outdoor/high-impact versions, apply the provided anti-seize lubricant to the first 2-3 unpainted threads of the housing.
5. Lift the housing/sunshield up to the mount and feed the cables through its top opening.
6. Place the housing onto the 1.5-inch pipe and screw clockwise, looking up at the housing. When it becomes snug, turn it an additional quarter-turn.
7. If using an alternate mounting configuration that uses an external (male) 1-1/2-in. pipe thread, a coupling adapter is required. Repeat steps 4, 5 and 6. Apply a watertight silicone (or equivalent) sealant after installation to avoid leakage. Refer to Alternate Mounting Configuration figure below.

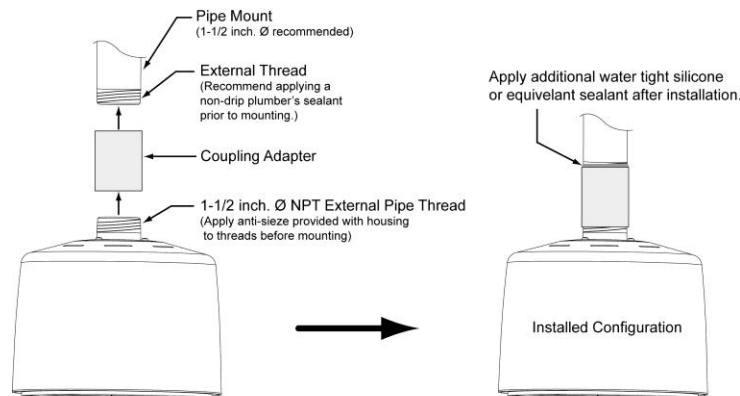

8. Remove terminal blocks from the accessory kit. The 2-pin (TB2) is for power, the 4-pin (TB5) is for control/relay and the 8-pin is for alarms.

9. Slide excess cable back up into the mount/pipe so that cable length is flush with the bottom of the housing, approximately 8 - 9 inches (203 - 229 mm).

Note

There should be minimal wire slack at all connection points.

10. Install the terminal blocks TB2, TB5 and TB1 into the Customer Interface Board at the proper block frames. Refer to the ***Installing the Cables*** sub-section of the Wiring section and Table 2 for detailed instructions on wiring the unit.
11. Swing the customer interface board back into place. If interface board was completely removed, be sure to reinstall it correctly, with the white connector near the wall of the enclosure. After wiring is complete, dress cables up over board.
12. Configure the Surveyor DIP switches on the main board and CI board at this time. Refer to the Setting the DIP Switch section of this manual.
13. Lift the Surveyor HD/SD camera drive up to the housing and attach the housing's safety cord clip to the camera drive's tab. See Figure below. Allow the drive to hang from the housing.

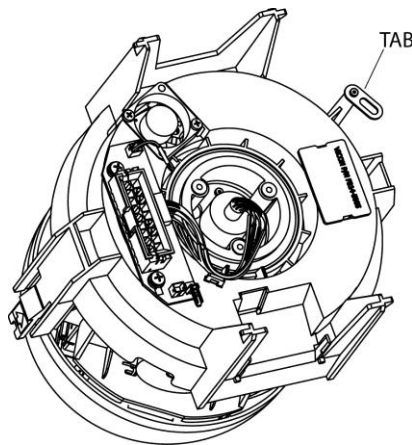

14. Align the tabs on the camera drive with the slots in the housing, matching up the arrows on the camera drive and the housing.

Warning

Cables having excessive slack can cause damage to the Surveyor HD/SD when installed into the housing.

15. Push the camera drive straight up into the housing until it snaps into the housing. Do not use excessive force. In the event that it does not snap easily, remove the Surveyor HD/SD and verify proper cabling.

16. Insert the clip of the safety cord from the lower dome into the hole on the inside of the housing. Refer to the installation label provided inside housing. Holding the lower dome, line up the 2 molded tabs on the lower dome with the 2 parallel surfaces of the housing. Push the lower dome up and verify that it snaps into place on both sides (indoor and outdoor versions). See Figure below.

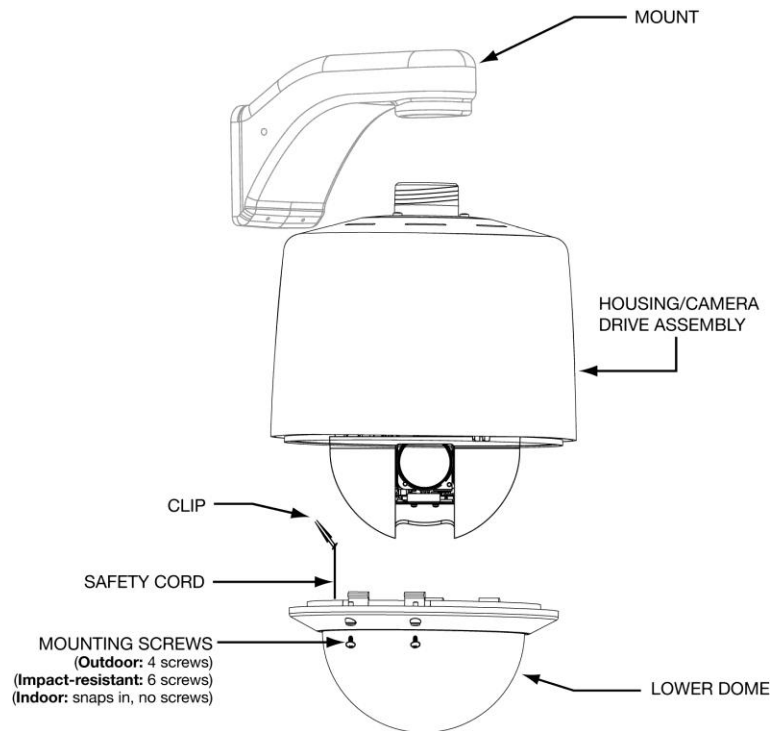

17. On the outdoor unit, tighten the 4 trim ring captive screws to hold the lower dome in place. Verify proper orientation of the grommet. On the impact-resistant version, there are 6 screws.
18. Proceed to the Operation section of this manual.

Chapter 3

Wiring

3

This chapter will describe how to wire, configure and operate the Surveyor HD/SD Network Dome.

The chapter consists of the following topics:

Topic	Page
Wiring the Surveyor HD/SD Network Dome.....	3-2
Typical Relay and Alarm Connections	3-3
Installing the Cables	3-5
Setting the DIP Switches	3-8
Communication Ports	3-9

Wiring the Surveyor HD/SD Network Dome

Wiring is done with runs of cable for power, network and control. Optional wiring can be installed for the alarm input. Refer to the Technical Information section for all electrical requirements.

Power

Power cables carry AC power and are usually a two-conductor type ranging in size from 20 to 16 AWG. The power source used should be a UL listed Class 2 indoor/dry or Class 3 outdoor/wet rated type power supply. The leads should be connected to Terminal Block 2 (TB2). The size of the two-conductor cable depends on indoor/outdoor application and cable distance as shown in the Table in the Technical Information section. On indoor units, PoE+ (Power over Ethernet) is provided through the RJ-45 connector (J6)

Video

Video is digitized and made available through the RJ-45 LAN connection (J6). Refer to the Reference section of this manual for information on recommended cable types and maximum distances; communication signals are digitized and are made available through the RJ-45 LAN connection. Refer to figure below.

Control

Communication signals are digitized and are made available through the RJ-45 LAN connection.

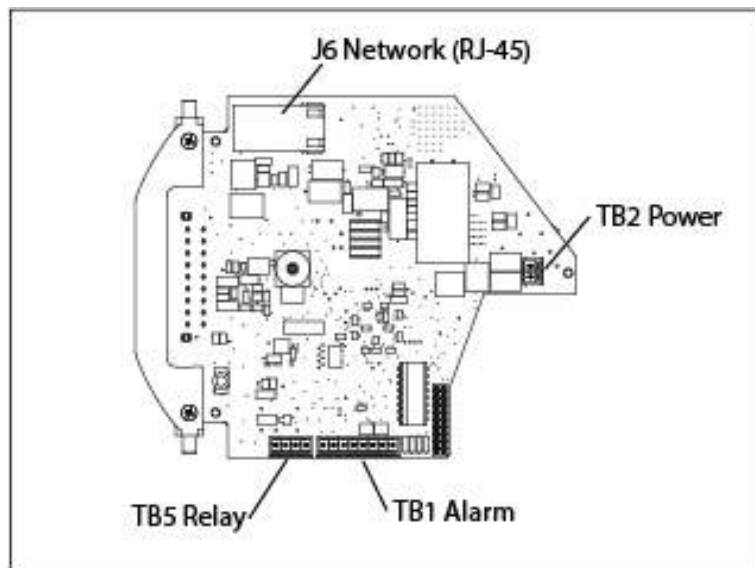

Typical Relay and Alarm Connections

Alarm input and relay output type signals are also carried on individually-shielded twisted-pair cable sets. The signals are defined in the following descriptions.

Note

The twisted-pair cable should have a wire gauge (AWG) of 24-16 and a category type of 2, 3, 4, 5 or better.

Alarms 1-4 are electronic CMOS level type inputs that are driven by a dry contact type switch. These signals are connected to terminal block TB1. Each input has two states, open and closed. For example, in the figure below, a door switch can activate an alarm when connected to a Surveyor HD alarm input. As a guideline (under normal conditions), the cable should be 22 AWG for a 1000 foot (305 m) distance. The states correspond to defined TTL designations as follows:

OPEN = HIGH and CLOSED = LOW
 where: HIGH = 5 VDC and LOW = < 1 VDC

Since dry contact switches are normally defined in terms of their inactive or “normal” state, the following holds true:

NORMALLY CLOSED (NC) = ACTIVE HIGH (OPEN)
 NORMALLY OPEN (NO) = ACTIVE LOW (CLOSED)

Note:

Diagram below shows Surveyor HD In-Ceiling version. This is for illustration purposes only; connections are the same for other versions.

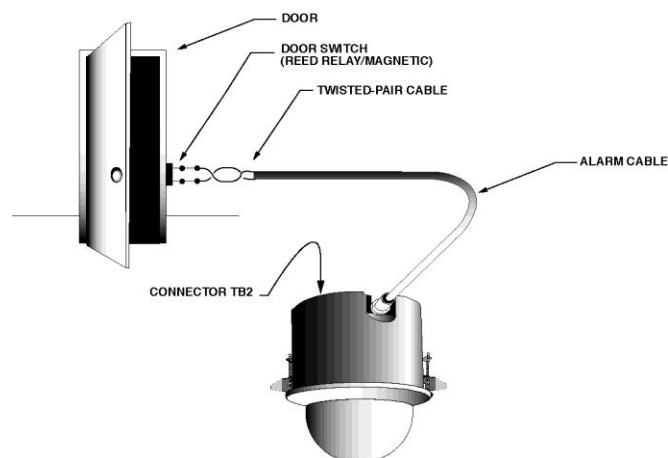

The “active” state can be programmed through the Surveyor HD web browser interface. These signals are connected to terminal block TB1. Alarm signals can be programmed for their status (enabled/disabled), active level definition (high/low), action/reset function (none, preset, aux on, aux off or tour), acknowledgment mode (automatic, momentary or manual) and report status (active/inactive). Refer to manual XX214-40 for details, as needed.

The relay output is an actual relay output dry contact, which directly drives external devices (1.5 A @30 VDC max). For example, a light can be turned on and off when the relay output is connected to the light circuit. Refer to figure below. The relay output contact can be programmed for its power-on state definition (on/off) and output type definition (momentary or latching).

There is one relay output dry contact located on terminal block TB5. Connect the circuit to be switched to the connector pins labeled RELAY C (relay common) and RELAY NC or RELAY NO for a normally closed or normally open connection, respectively.

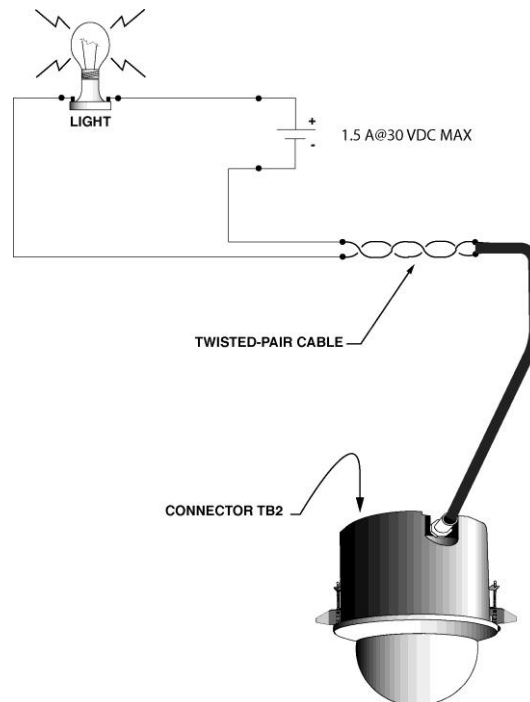

Installing the Cables

Warning

Disable the AC power to prevent installer injury and damage to the unit.

Cables are installed using 2 different methods, depending on the installation type. For the in-ceiling installation, cables are routed from above the ceiling through a conduit fitting on the enclosure to the customer interface board. For the pendant installation, cables are routed from the inside of the housing to the customer interface board. In all cases, there should be minimal wire slack at all connection points. After wiring is complete, dress the cables so they are up over the board. Refer to the Figure at the end of this section for customer interface board connections.

For an In-Ceiling Installation

1. Place all cables through the conduit fitting on the side of the enclosure. Verify that all cables have been routed through 0.75 inch (19 mm) rigid or flexible conduit pipe.

Note

If conduit pipe is not used, the supplied strain relief fitting must be installed in place of the one installed to provide sufficient cable strain relief.

2. If using flexible conduit, cut all cables to their approximate required lengths. Leave approximately 1 inch (25 mm) extra for termination. Tighten fitting.
3. Remove terminal blocks from the accessory kit. The 2-pin is for power (TB2), the 4-pin is for relays (TB5) and the 8-pin is for alarms (TB1).
4. Strip approximately 1 in. (25 mm) of the cable outer jacket used for power, control, alarms and relays. Then strip approximately 0.25 inches (6 mm) of insulation off of each individual wire.
5. Terminate the 8-conductor alarm cable and 4-pin relay/control signal cable.
6. Make all connections to terminal blocks TB2 (power), TB1 (alarms), TB5 (relays/control signals) with reference to Table 2.
7. Install the terminal blocks TB1, TB2, TB5 into the Customer Interface Board at the proper block frames.
8. Connect an RJ-45 connector to J6 on the board.
9. On installations not using flexible conduit, slide back excess cable and insert the conduit pipe into the conduit fitting and tighten the screw.

For an Indoor or Outdoor/High-Impact Pendant Model Installation

Refer to the Figure at the end of this section for customer interface board connections.

1. Route each cable from the inside top of the housing.
2. Remove terminal blocks from the accessory kit. The 2-pin is for power (TB2), the 4-pin is for relays (TB5) and the 8-pin is for alarms (TB1).
3. Strip approximately 1 inch (25 mm) of the cable outer jacket used for power, control, alarms and relays. Then strip approximately 0.25 inches (6 mm) of insulation off of each individual wire.
4. Terminate the 8-conductor alarm cable and 4-pin relay/control signal cable.
5. Make all connections to terminal blocks TB2 (power), TB1 (alarms), TB5 (relays/control signals) with reference to Table 2.
6. Slide excess cable back up into the mount/pipe so that cable length is flush with the bottom of the housing, approximately 8 to 9 inches (203 to 229 mm).
7. Install the terminal blocks TB1, TB2, TB5 into the customer interface board at the proper block frames. Connect an RJ-45 connector to J6 on the board.

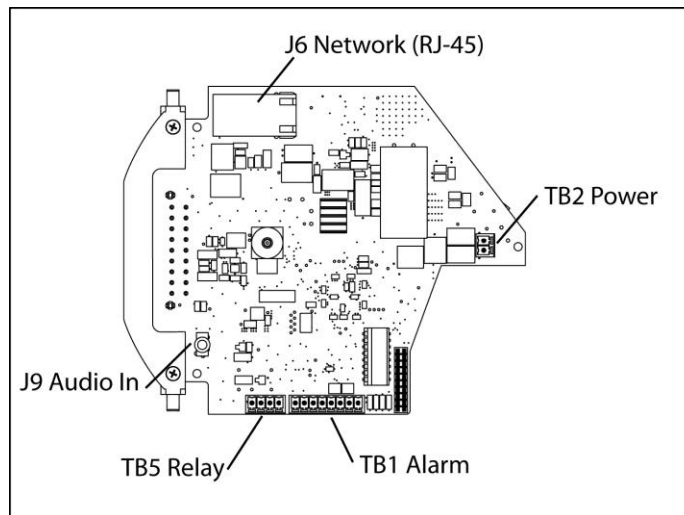

Table 3: Wiring Connections

CONNECTOR/PIN NUMBER	CONNECTOR TYPE	CONNECTOR/PIN LABEL	SIGNAL NAME
	TERMINAL BLOCK	POWER (TB2)	
TB2-1		AC+	Hot
TB2-2		AC-	Neutral
	TERMINAL BLOCK	ALARM (TB1)	
TB1-1		ALARM 1	Alarm I/O 1
TB1-2			Ground
TB1-3		ALARM 2	Alarm I/O 2
TB1-4			Ground
TB1-5		ALARM 3	Alarm I/O 3
TB1-6			Ground
TB1-7		ALARM 4	Alarm I/O 4
TB1-8			Ground
	TERMINAL BLOCK	COMM/RELAY (TB5)	
TB5-1		VSS	Ground
TB5-2		C	Relay, common
TB5-3		NO	Relay, normally open
TB5-4		NC	Relay, normally closed
	RJ-45	LAN (J6)	
J6-1			Transmit +
J6-2			Transmit -
J6-3			Receive +
J6-4			PoE spare
J6-5			PoE spare
J6-6			Receive -
J6-7			PoE spare
J6-8			PoE spare
	1/8-IN. PHONO	AUDIO (J9)	
J9		J9	Audio In

Setting the DIP Switches

There are two DIP switches that must be set on the Surveyor HD. One is on the Communications Interface (CI) board and one on the Main board.

SW1 4-position DIP switch is on the Communication Interface (CI) board. For SW1 all poles should be set to OFF (default).

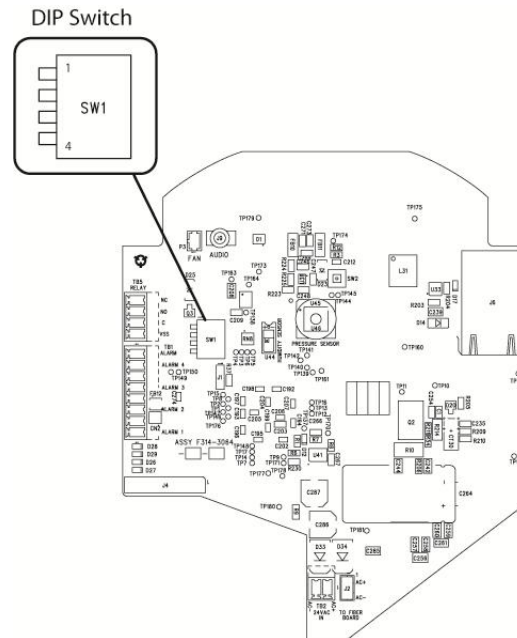

DIP Switch Location on CI Board

Caution

Changing the positions on the DIP switch on the Main board should only be done by a qualified person. Position 1 is used only if it is necessary to force the unit into default setup if network or system connections are lost. Be sure to reset this switch back to the OFF position before the next power up to avoid a constant return to defaults, resulting in not being able to enter the camera's IP to use the Web Browser. The camera dome is shipped with a default static IP of 1.1.1.2.

The Main board has an 8-position DIP switch SW1. The settings for the positions of this DIP Switch are:

Position 1 - Set Network Address. OFF = Default Position, do not set network defaults. ON = Set default network address (1.1.1.2); must be reset OFF after reboot and before next power up.

Position 2 – For factory use only. Set to ON for SD version only; set to OFF to for all other versions. DO NOT CHANGE.

Position 3 – For factory use only. OFF is Default.

Position 4 – Unused (set to OFF)

Position 5 – Unused (set to OFF)

Position 6 – Set NTCIP. OFF = Default Position, NTCIP Enabled.
ON = NTCIP disabled.

Position 7 – Set password. OFF = Default Position. ON = Reset to default password (**password** or **1234**); must be reset to OFF after reboot and before next power up.

Position 8 – System Mode. OFF = Default Position, ViconNet Mode.
ON = ONVIF/NTCIP Mode.

The main board is located underneath the housing. It may be necessary to spin the housing mechanism to see the DIP switch, located near the tilt motor along edge of the board.

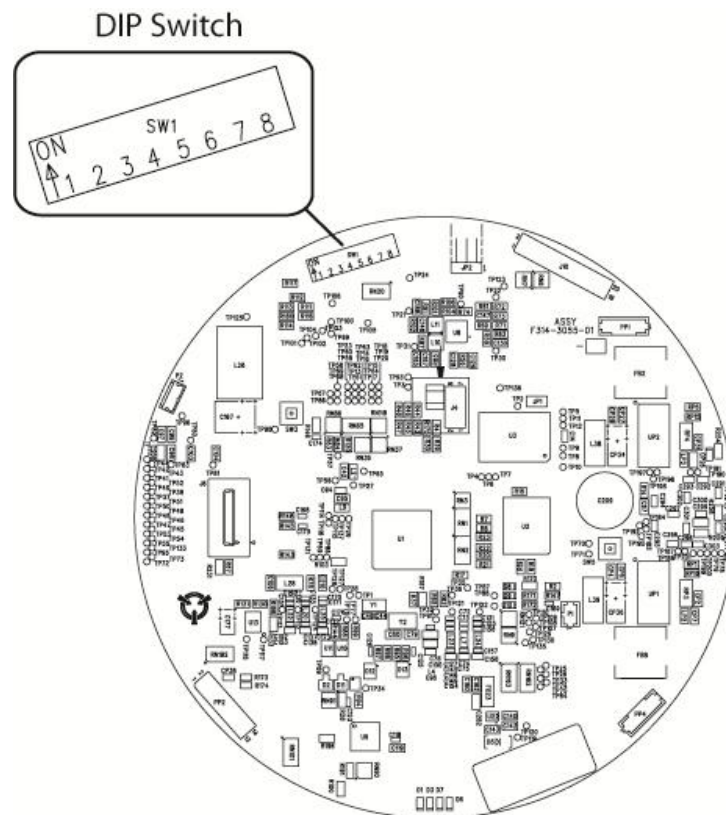

Communication Ports

If using NTCIP protocol, communicate to the Surveyor HD/SD using ports 3000/UDP or 3001/TCP.

If using ONVIF, use port 8000.

This page left intentionally blank

Chapter 4

Operation, Maintenance and Reference

4

This chapter provides Operation instructions, Maintenance information, cable recommendations and technical specifications for the Surveyor HD/SD Network Dome.

The chapter consists of the following topics:

Topic	Page
Operation	4-2
Maintenance	4-3
Shipping Instructions	4-5
Technical Specifications	4-7
Vicon Standard Equipment Warranty	4-11

Operation

The Surveyor HD/SD Camera Dome operates on an Onvif Profile S compliant platform that allows it to work with any Onvif compliant Video Management System (VMS), including Vicon's ViconNet.

Refer to the documentation for those operating systems to setup the Surveyor HD/SD. After the camera dome is configured according to the requirements for the specific video management system, it is controlled through the Web Browser interface. Refer to web browser instruction manual, XX214-40.

Maintenance

The Surveyor HD/SD requires no scheduled maintenance; however, the lower domes require occasional cleaning. The clear and smoked domes are referred to as acrylic type domes. The chrome and gold domes are referred to as metallized type domes. All domes require careful handling and occasional cleaning.

Care and Cleaning of Smoked and Clear Acrylic Domes

1. Always handle the lower dome by the flange and avoid touching the inside surface.
2. If dust or dirt accumulates in the lower dome's interior, remove it with clean, dry pressurized air.
3. If spots, streaks or stains appear on the interior or exterior, they may be removed with an approximate solution of 50% isopropyl alcohol and 50% water using a soft microwave-safe (aluminum free) paper towel. Dry with clean, dry pressurized air.
4. Scratches or surface blemishes on the interior or exterior may be removed with a nonabrasive wax using a nonabrasive cleaning cloth. Either liquid or spray cleaner (wax suitable for fine furniture) is acceptable.

Caution

Excessive rubbing of the lower dome surface can cause permanent scratches that may render the dome unusable.

5. Clean all surfaces with any soft, nonabrasive cleaning cloth and a cleaning agent suitable for acrylic plastic.

Care and Cleaning of Metallized Domes

1. Always handle the lower dome by the flange and avoid touching the inside surface, as acid in a fingerprint can etch the internal coating. Use the recommended cleaning procedure in Step 4.
2. If dust or dirt accumulates in the lower dome's interior, remove it with clean, dry pressurized air.
3. If spots, streaks or stains appear on the interior, they can be removed by rinsing with clean water and drying with clean, dry pressurized air. Do not rub the inner surface.

Caution

Rubbing the inner surface of metallized lower domes can cause permanent scratches that may render the dome unusable.

4. If cleaning of the inner surface is necessary, use a wick. Make a wick by rolling a section of soft microwave-safe (aluminum free) paper towel into a tightly wound tube and tear it in half. Moisten the torn edge of the wick with an approximate solution of 50% isopropyl alcohol and 50% water. Hold the Lower Dome upside down and gently wipe the inner surface from the inside to the outer edge. Use a new wick for each 2 passes over the dome.
5. Clean the lower dome's exterior with any soft, nonabrasive cleaning cloth and a cleaning agent suitable for acrylic plastic. Either liquid or spray cleaner (wax suitable for fine furniture) is acceptable.

Fuse Replacement

The Surveyor HD/SD has two resettable 1.35 A, 72 V fuse. Be sure to use a fuse of the same value if it is necessary to replace the fuse.

Shipping Instructions

Use the following procedure when returning a unit to the factory:

1. Call or write Vicon for a Return Authorization (R.A.) at one of the locations listed below. Record the name of the Vicon employee who issued the R.A.

Vicon Industries Inc.
131 Heartland Boulevard
Edgewood, NY 11717
Phone: 631-952-2288; Toll-Free: 1-800-645-9116; Fax: 631-951-2288

For service or returns from countries in Europe, contact:

Vicon Europe Ltd.
Brunel Way
Fareham, PO15 5TX
United Kingdom
Phone: +44 (0) 1489 566300; Fax: +44 (0)1489 566322

2. Attach a sheet of paper to the unit with the following information:
 - a. Name and address of the company returning the unit
 - b. Name of the Vicon employee who issued the R.A.
 - c. R. A. number
 - d. Brief description of the installation
 - e. Complete description of the problem and circumstances under which it occurs
 - f. Unit's original date of purchase, if still under warranty
3. Pack the unit carefully. Use the original shipping carton or its equivalent for maximum protection.

Mark the R.A. number on the outside of the carton on the shipping label.

Network Cable

Caution

Careful selection of proper cable is essential to obtain the best performance. Vicon assumes no responsibility for poor performance when cables other than the recommended types, or equivalent, are used. Vicon recommends using shielded cable.

Materials

Use pure copper stranded conductors to obtain a low DC resistance. The preferred insulation and cable jacket is Polyvinyl chloride (PVC). It has better electrical characteristics than Polyethylene and resists flames, sunlight and most solvents, but is more vulnerable to moisture.

Cable Types

The most commonly used cable types are CAT5, CAT5e and CAT6. These category cables are best suited for Ethernet network applications.

Choose a Belden cable type by referring to the characteristics listed below. The Table below should be used as a guideline when cables other than Belden are used. Materials and construction must follow the guidelines above.

CABLE TYPE	WIRE SIZE (AWG)	INSULATION MATERIAL	JACKET MATERIAL	CATEGORY	BANDWIDTH (MHz)	MAXIMUM DISTANCE (ft/m)	NUMBER OF TWISTED PAIRS
Belden 1624P (Shielded)	24	Fluorinated Ethylene Propylene	Low Smoke PVC	5	100	246/75	4

Belden Inc. <http://www.belden.com/> (800) 235-3361

Alarm/Relay Cable

Materials

Use a pure copper stranded conductor with or without a tin-plating to obtain a low DC resistance. Do not use cable with either steel or aluminum stranded conductor because they do not transfer signals effectively for long distances. The preferred insulation and cable jacket is Polyvinyl chloride (PVC). It has better electrical characteristics than polyethylene and resists flames, sunlight and most solvents, but is more vulnerable to moisture.

Cable Types

The most commonly used cable types are dual individually twisted pair in a single jacket. This configuration is the most convenient for the alarm/relay signal applications. Single twisted pair is also a suitable cable.

1.5-inch Pipe Designation

The standard “1.5-inch pipe” referred to in this manual has actual dimensions of:

Outside diameter: 1.9 inches (48.3 mm).

Inside diameter: 1.61 inches (40.9 mm).

Wall thickness: 0.145 inches (3.37 mm) minimum (ANSI “standard” grade thickness).

Technical Specifications

Network Video Transmission

Compression:	H.264, M-JPEG.
Video Streams:	8 concurrent sessions maximum.
Video Output:	720p (1 megapixel) version: Stream 1: 1280 x 720 @ 30 fps. 1080p (2 megapixel) version: Stream 1: 1920 x 1080 or 1280 x 720 @ 30 fps. Stream 2 (both versions): 640 x 352 @ 30 fps. VGA (SD) version: Stream 1: 720 x 480 @ 30 fps; Stream 2: CIF.
Programming Interface:	ONVIF, Profile S; NTCIP; or Vicon API.
Protocols:	IP, HTTP, RTSP/RTP, DNS client, FTP, SMTP, PPPoE, TCP/IP, DHCP, UDP, Multicast, NTP, DDNS, IGMP, ARP, SOAP, WSDL, WS-Discovery.

Electrical

Input Voltage:	18-30 VAC; PoE+ on indoor unit only. (Will operate within spec on voltages up to 32 VAC. For voltages between 30-32 VAC, use a Class 3 indoor/dry or outdoor/wet power supply.)
Current:	Indoor: 1.0 A maximum. Outdoor: 2.2 A maximum.
Power Consumption:	Indoor: 20 W maximum. Outdoor: 70 W maximum.
Maximum Operating Distance	Refer to Maximum Power Distance Table that follows.
Fuse:	Two Resettable 1.35 A, 72 V.
Certifications:	UL; CE; FCC Class A.

Camera and Optics

Image Device:	720p (1 MP version): 1/3-in.h progressive scan CCD. 1080p (2MP) version: 1/2.8-in. progressive scan CMOS. VGA (SD) version: 1/4-in. CCD progressive scan ExView.
Zoom:	720p (1 MP version): 30X optical. 1080p (2MP) version: 20X optical. VGA version: 36X optical.
Picture Elements:	720p (1 MP version): 1348 (H) x 746 (V), 1.02M total pixels. 1080p (2MP) version: 1952 (H) x 1236 (V); 2.4M total pixels. VGA (SD) version: 811 (H) x 508 (V), 411,988 total pixels.

Sensitivity:	720p (1 MP version): Color: 0.3 lux; 1/30s, IRcf On. B&W: 0.003 lux) at 30 IRE, f/1.4, 1/4s, IRcf Off. 1080p (2MP) version: Color: 0.25 lux ; 1/30s, IRcf On. B&W: 0.006 lux) at 30 IRE, f/1.6, 1/8s, IRcf Off. VGA (SD) version: Color: 0.5 lux; IRcf On. B&W: 0.01 lux) at 50 IRE, f/1.4, 1/4s, IRcf Off
Synchronization:	HD versions: Internal. VGA (SD) version: Internal/External.
Gain Control:	Automatic/Manual.
Backlight Compensation:	On/Off, selectable.
Iris Control:	Automatic.
Wide Dynamic Range:	On/Off, selectable.
Video Focus:	Automatic/Manual (near-far).
White Balance:	Automatic/Manual; Red/Blue gain adjustable.
Shutter Speed:	720p (1 MP version): Automatic/Manual: 1/4 - 10,000 sec. 1080p (2MP) version: Automatic/Manual: 1/8 - 30,000 sec. VGA (SD) version: Automatic/Manual: 1/4 - 10,000 sec.
Focal Length:	720p (1 MP version): 4.4 - 132 mm. 1080p (2MP) version: 4.7 - 94 mm. VGA (SD) version: 3.3 – 119 mm.
Aperture:	720p (1 MP version): f/1.4 (wide) - f/4.6 (tele). 1080p (2MP) version: f/1.6 (wide) - f/3.5 (tele). VGA (SD) version: f/1.4 (wide) - f/4.2 (tele).
Angle of View:	720p (1 MP version)n: Horizontal: 62.9° wide, 2.2° tele. 1080p (2MP) version: Horizontal: 59.6° wide, 3.29° tele. VGA (SD) version: 60.2° wide, 1.8° tele.

Operational

Drive Type:	Electrical motorized pan and tilt with electronic control.
Pan View:	360° continuous.
Tilt View:	-2.5 to 92.5°.
Pan Speed:	400°/sec, max.
Tilt Speed:	150°/sec, max.
Optical Zoom/Focus Speed:	1.8 sec, tele to wide.
Preset Capability:	79 individually programmable.
Preset Solving Speed:	1 second nominal.

Preset Accuracy (Pan and Tilt):	0.1° maximum.
Tour Capabilities:	8 tours available. 32 programmable events per tour. Events may be preset positions with speed control, alarm acknowledge, dwell time control, relay control, call autotours, tour repeat or another tour, save/recall camera status.
Autotour Capabilities:	2 autotours available with 256 pan, tilt and zoom functions per autotour. Programming is done in real time with joystick and push buttons.
Sectoring:	16 maximum, programmable for size and titling. Sectors have the capability to be blanked out.
Alarm Capabilities:	4 alarm inputs, individually programmable. Functional state enable/disable. Report state (report on/off). Active state (high/low). Mode (manual, momentary or automatic) with programmable dwell time control. Set and reset action (preset solve, relay on/off, tour, autotour). Alarm titling.
Alarm Output:	1 relay, momentary or latching.
Control Display:	Web browser interface.
Privacy Masks:	80 total; 64 rectangular, 16 irregular shape. 10 individual simultaneously on-screen; Programmable, zoom-scalable.
Scheduling:	Real-time clock allows scheduling of up to 32 events, including presets, relays, alarms, tours or autotours.
Multi-Language Menu:	English, Spanish, French, Italian and German.
Camera Features:	Motion detection and image freeze during preset solve. Programmable.
Screen Titling Capabilities:	Programmable for camera, time/date, preset, sector, lens, aux and alarms. Pressurized version only: pressure, humidity and temperature. Compass/azimuth, 8 compass headings (N, NE, E, SE, S, SW, W, NW). 20 characters maximum; selectable position. Two text sizes for top 2 lines. Fade capability (except for camera, time/date and alarm).

Environmental

Operating Temperature Range:	Indoor units: 32 to 132° F (0 to 55° C). Outdoor units-40 to 132° F (-40 to 55° C).
Operating Humidity Range:	Indoor: 0 to 90% relative, non-condensing. Outdoor: 100% relative, non-condensing.

Storage Temperature Range:	-40 to 150° F (-40 to 65° C).
Storage Humidity Range:	0 to 90% relative, non-condensing.
Rain/Wind:	Outdoor: Heavy rain up to 4 in./hr at winds up to 90 mph, when mounted on standard Vicon wall mount.
Compliance:	International Protection (IP) Ratings: Outdoor/Impact-Resistant: IP66, NEMA 4X; NEMA TS2-2003 V02.06. Indoor Pendant: IP52. In-Ceiling: IP51.

Maximum Power Cable Distances Table

Wire Size (AWG) Annealed Copper Wire	Distance ft (m)	
	Indoor	Outdoor
	24 VAC	24 VAC
20	192 (57)	87 (27)
18	307 (93.6)	140 (43)
16	489 (149)	222 (68)
14	775 (236)	352 (107)
12	1235 (376)	561 (171)

Vicon Standard Equipment Warranty

Vicon Industries Inc. (the “Company”) warrants your equipment to be free from defects in material and workmanship under Normal Use from the date of original retail purchase for a period of three years, with the following exceptions:

1. Uninterruptible Power Supplies: Two years from date of original retail purchase.
2. VDR-700 Recorder Series: One year from date of original retail purchase.
3. V5616MUX: One year from date of original retail purchase.
4. Arecont Cameras: One year from date of original retail purchase.
5. FMC series fiber-optic media converters and associated accessories: Lifetime warranty.
6. For PTZ cameras, “Normal Use” excludes prolonged use of lens and pan-and-tilt motors, gear heads, and gears due to continuous use of “autopan” or “tour” modes of operation. Such continuous operation is outside the scope of this warranty.
7. Any product sold as “special” or not listed in Vicon’s commercial price list: One year from date of original retail purchase.

Date of retail purchase is the date original end-user takes possession of the equipment, or, at the sole discretion of the Company, the date the equipment first becomes operational by the original end-user.

The sole remedy under this Warranty is that defective equipment be repaired or (at the Company’s option) replaced, at Company repair centers, provided the equipment has been authorized for return by the Company, and the return shipment is prepaid in accordance with policy.

The Company will not be obligated to repair or replace equipment showing abuse or damage, or to parts which in the judgment of the Company are not defective, or any equipment which may have been tampered with, altered, misused, or been subject to unauthorized repair.

Software supplied either separately or in hardware is furnished on an “As Is” basis. Vicon does not warrant that such software shall be error (bug) free. Software support via telephone, if provided at no cost, may be discontinued at any time without notice at Vicon’s sole discretion. Vicon reserves the right to make changes to its software in any of its products at any time and without notice.

This Warranty is in lieu of all other conditions and warranties express or implied as to the Goods, including any warranty of merchantability or fitness and the remedy specified in this Warranty is in lieu of all other remedies available to the Purchaser.

No one is authorized to assume any liability on behalf of the Company, or impose any obligations on it in connection with the sale of any Goods, other than that which is specified above. In no event will the Company be liable for indirect, special, incidental, consequential, or other damages, whether arising from interrupted equipment operation, loss of data, replacement of equipment or software, costs or repairs undertaken by the Purchaser, or other causes.

This warranty applies to all sales made by the Company or its dealers and shall be governed by the laws of New York State without regard to its conflict of laws principles. This Warranty shall be enforceable against the Company only in the courts located in the State of New York.

The form of this Warranty is effective July 1, 2014.

THE TERMS OF THIS WARRANTY APPLY ONLY TO SALES MADE WHILE THIS WARRANTY IS IN EFFECT. THIS WARRANTY SHALL BE OF NO EFFECT IF AT THE TIME OF SALE A DIFFERENT WARRANTY IS POSTED ON THE COMPANY’S WEBSITE, WWW.VICON-SECURITY.COM. IN THAT EVENT, THE TERMS OF THE POSTED WARRANTY SHALL APPLY EXCLUSIVELY.

Vicon Industries Inc.

For office locations, visit the website:

www.vicon-security.com

