



User Manual

**PowerLine HD Day/Night Cloud Camera
PowerLine HD Day/Night Cloud Camera kit**

DCS-6045L/DCS-6045LKT

Manual Overview

D-Link reserves the right to revise this publication and to make changes in the content hereof without obligation to notify any person or organization of such revisions or changes. Information in this document may become obsolete as our services and websites develop and change. Please refer to the www.mydlink.com website for the most current information.

Manual Revision

Revision	Date	Description
1.00	03/15, 2014	Initial release
1.10	02/11/2015	add Power Usage

Trademarks

D-Link and the D-Link logo are trademarks or registered trademarks of D-Link Corporation or its subsidiaries in the United States or other countries. All other company or product names mentioned herein are trademarks or registered trademarks of their respective companies.

Copyright © 2015 by D-Link Corporation.

All rights reserved. This publication may not be reproduced, in whole or in part, without prior expressed written permission from D-Link Corporation.

Power Usage

This device is an Energy Related Product (ErP) that automatically switches to a power-saving Network Standby mode within 1 minute of no packets being transmitted. It can also be turned off through a power switch to save energy when it is not needed.

Network Standby: 4.3 watts

Switched Off: 0.1 watts

Table of Contents

Product Overview	4	Setup.....	27
Package Contents.....	4	Wizard.....	27
System Requirements.....	4	Internet Connection Setup Wizard.....	28
Introduction.....	5	Network Setup.....	30
Features.....	6	DDNS.....	31
DCS-6045L Hardware Overview.....	7	Image Setup.....	32
Front View.....	7	Audio and Video.....	33
Rear View.....	8	Time and Date.....	34
DHP-308AV Hardware Overview.....	9	Mail.....	35
Front View.....	9	FTP.....	37
Rear View.....	10	SD Recording.....	39
Rear View.....	11	Motion Detection.....	41
Installation	14	Sound Detection.....	42
Zero Configuration Setup.....	15	SD Management.....	43
Camera Installation Wizard.....	18	Maintenance.....	44
Windows Users.....	18	Admin.....	44
Mac Users.....	19	System.....	45
PLC - Push Button Setup.....	20	Firmware Upgrade.....	46
Manual Hardware Installation.....	21	Status.....	47
Mounting The Camera.....	22	Device Info.....	47
mydlink.....	24	Active User.....	48
Configuration	25	Troubleshooting	49
Using the Web Configuration Interface.....	25	Technical Specifications	52
Live Video.....	26		

Package Contents

- DCS-6045L PowerLine HD Day/Night Cloud Camera
- Mounting Kit with Screws
- Power Cord
- Quick Install Guide
- Manual and Software on CD
- DHP-308AV (Only included with the DCS-6045LKT Starter Kit)

Note: Using a power supply with a different voltage than the one included with your product will cause damage and void the warranty for this product.

If any of the above items are missing, please contact your reseller.

System Requirements

- Computer with Microsoft Windows® 8/7/Vista/XP, or Mac with OS X 10.6 or higher
- PC with 1.3 GHz or above and at least 128 MB RAM
- Internet Explorer 7, Firefox 12, Safari 6, or Chrome 20 or higher version with Java installed and enabled
- Existing 10/100 Ethernet-based network

Introduction

Congratulations on your purchase of the DCS-6045L PowerLine HD Day/Night Cloud Camera. The DCS-6045L is a versatile and unique solution for your small office or home. Unlike a standard webcam, the DCS-6045L does away with traditional wired or wireless connections and instead uses your existing electrical wiring. The DCS-6045L plugs directly into a power outlet, and does not require any additional cables. Designed to be used with any D-Link PowerLine adapter, which turns every power outlet into a possible network connection to access digital media devices, game consoles, print servers, computers, and network storage devices throughout your home. A complete system with a built-in CPU and web server, the DCS-6045L transmits high quality video images for round-the-clock security and surveillance. The IR LED provides around the clock surveillance regardless of the lighting conditions.

The DCS-6045L is a standalone surveillance camera that requires no special hardware or software, and can run independently even without a PC. Send e-mail notifications with snapshots or video clips whenever motion or sound is detected using just the DCS-6045L and an Internet connection. You can customize areas of the video to monitor for motion to keep watch over entry ways, and you can set volume limits to detect when a loud sound is picked up by the camera. Night time monitoring is possible with the built-in infrared LEDs which allow for night time viewing of up to 6 meters (19.6 feet), enabling round-the-clock monitoring of a home or small office.

Built mydlink™ support DCS-6045L makes it easier and more convenient for you to look after your family, home, or office environment. With a mydlink service enabled camera, you can stay connected to everything you love from anywhere, anytime. The mydlink service can be accessed using a web browser, and there is also an optional downloadable mydlink app that allows users to have a better experience on their mobile devices. With the mydlink app, you can quickly and easily view your camera feed from anywhere using a Wi-Fi, 3G, or 4G connection.

Features

Easy to Use and mydlink-Enabled for Easy Access and Management

The DCS-6045L is a standalone surveillance camera that requires no special hardware or software, and can run independently even without a PC. This camera is also mydlink-enabled, which means you can view and manage your camera through the mydlink website, or through the mydlink mobile app for iPhone, iPad, iPod touch, and Android.

Data Transmission Over Electrical Wiring

The DCS-6045L plugs directly into a power outlet, and does not require any additional cables. Designed to be used with any D-Link PowerLine adapter, which turns every power outlet into a possible network connection to access digital media devices, game consoles, print servers, computers, and network storage devices throughout your home.

IR LEDs for Day and Night functionality

The built-in infrared LEDs enable night time viewing of up to 6 meters (19.6 feet).

H.264 Codec for Smooth, Space-Efficient Video

This camera supports use of the H.264 video codec, which gives you high-quality video with reduced bandwidth requirements. This means that you can enjoy smoother, more reliable video streaming over the Internet, and less disk space is required to save recordings.

Motion and Sound Triggered Notifications and Recordings

The DCS-6045L can send e-mail notifications with snapshots or video clips whenever motion or sound is detected. You can customize areas of the video to monitor for motion to keep watch over entry ways, and you can set volume limits to detect when a loud sound is picked up by the camera.

Supports a Variety of Platforms

Supports TCP/IP networking, HTTP, and other Internet related protocols. The DCS-6045L can also be integrated easily into other Internet/Intranet applications because of its standards-based features.

Remote Monitoring Utility

This camera also includes the D-ViewCam software, which adds enhanced features and functionality that helps you create a full surveillance system for up to 32 cameras. With D-ViewCam, you can view multiple cameras at the same time, record video, and set up scheduled and triggered recordings.

DCS-6045L Hardware Overview

Front View

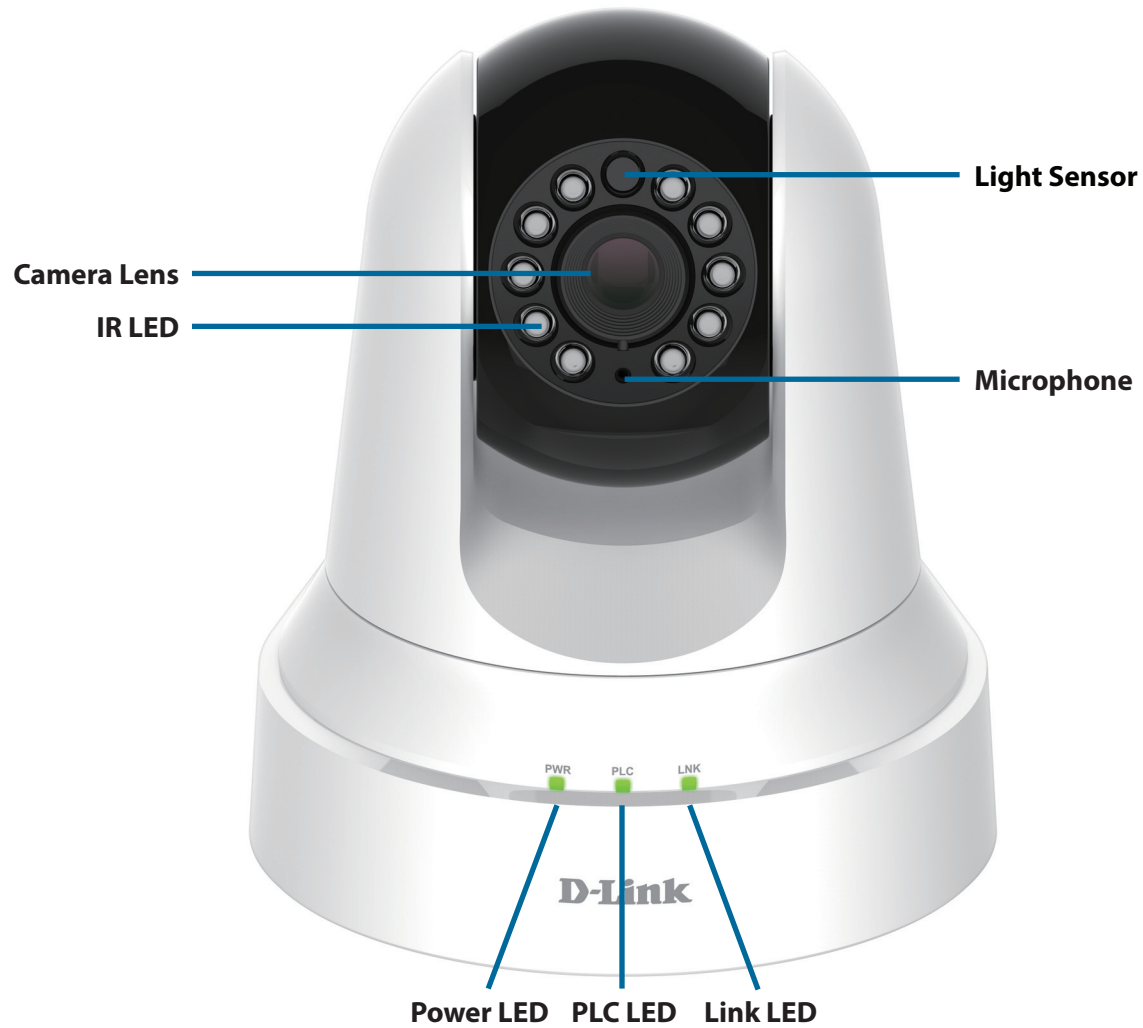

Rear View



DHP-308AV Hardware Overview

Front View

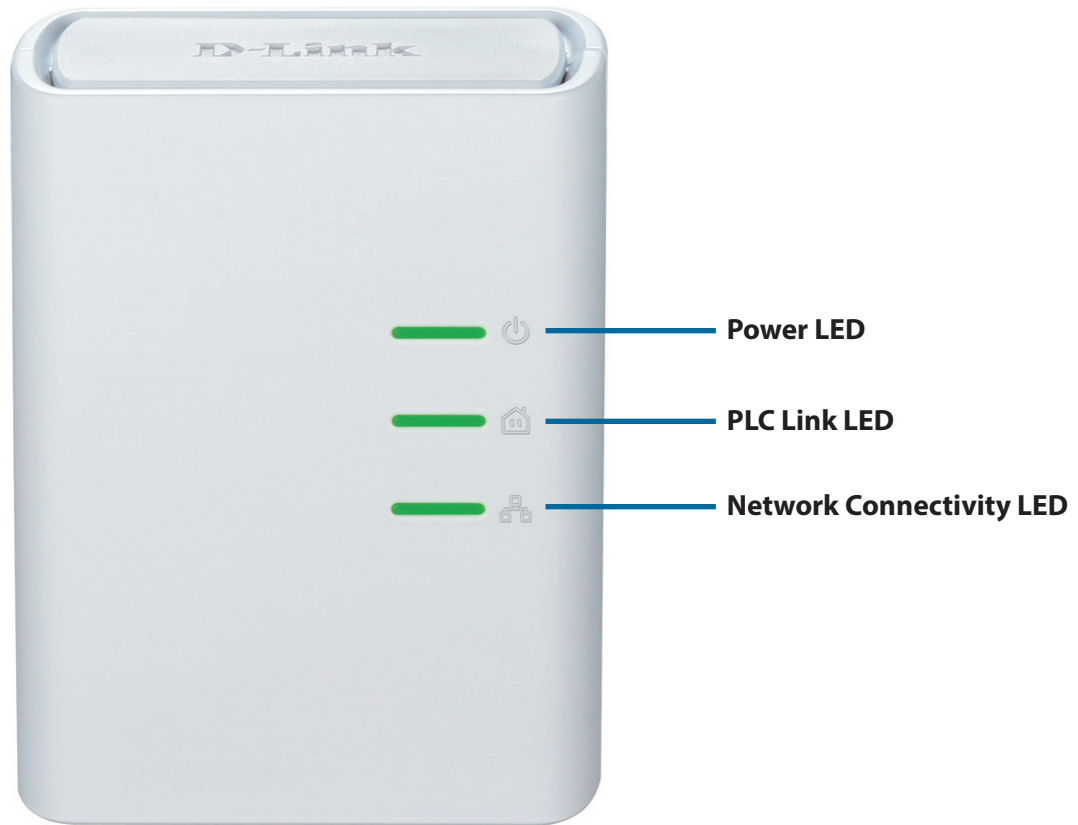

Rear View

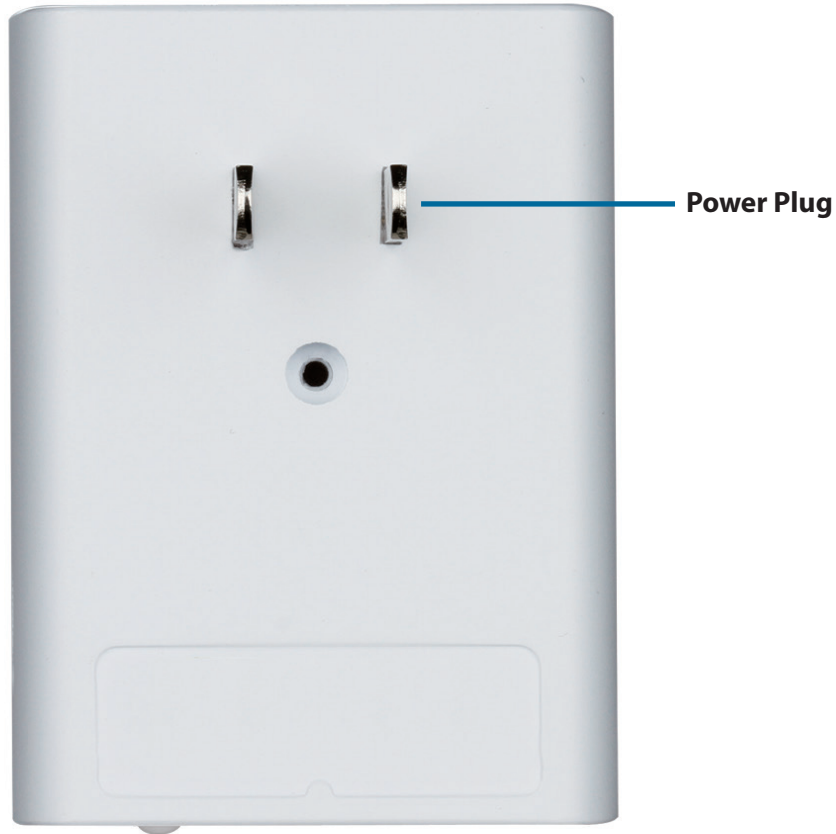

Rear View

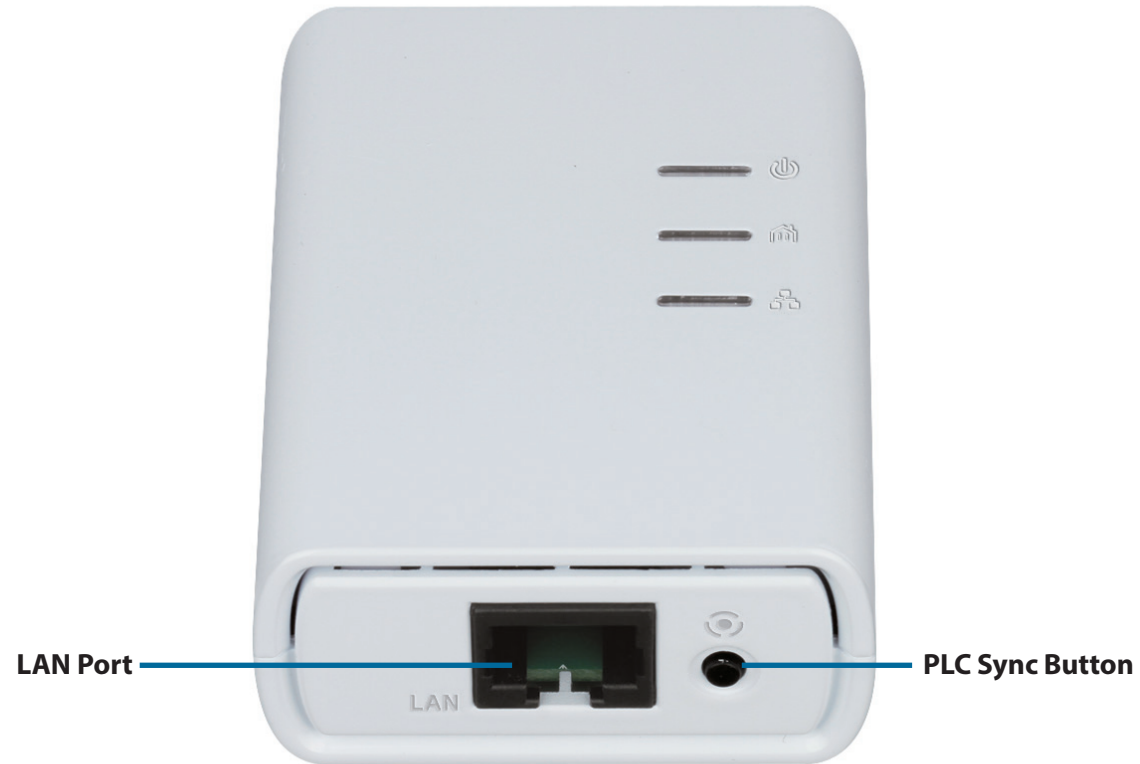

PowerLine Installation Considerations

Plan the location of your PowerLine devices:

1. Connect PowerLine devices to electrical outlets that are not controlled by a wall switch to avoid accidentally turning off power to the device.
2. Do not connect the PowerLine devices to an extension cord, surge protector, or power strip as this might prevent it from working correctly, or reduce the network performance.
3. Avoid using the PowerLine devices in an electrical outlet that is located near an appliance that uses a lot of power, such as a washer or dryer, or a refrigerator. This may prevent the adapter from working correctly, or negatively impact network performance.
4. Verify that your PowerLine devices are electrically rated to operate with the power available in your location.
5. To help prevent against electrical shock, be sure to plug the power cables into properly grounded electrical outlets.
6. The PowerLine device is equipped with a three-pronged plug to help ensure proper grounding. Do not use adapter plugs or remove the grounding prong from the cable.



Important safety instructions

Please read all of the safety and operating instructions before using your device:

1. Do not open the device or attempt to repair or service the device.
2. Only use the included power adapter to power your device.
3. Ensure that the device is plugged into the wall in a vertical position, with the ports facing down.
4. The AC socket-outlet of equipment was intended to be connected with AC power supply cord only, and no any direct plug-in equipment can be plugged.
5. Use the device in a dry location, and avoid placing it in humid environments.
6. Do not submerge the device in liquid or attempt to clean it with liquids or solvents. To clean the device, disconnect it from the power outlet and use a damp towel.
7. Keep the device out of direct sunlight.
8. Do not cover or block the vents on the device.
9. Make sure that the device has adequate room for ventilation.
10. Avoid placing the device near a heater or radiator.
11. The device should be located only where sufficient ventilation can be ensured.

Installation

There are three ways to set up your camera:

Zero Configuration Setup: If you have a mydlink-enabled router, this is the easiest way to set up your camera. Refer to page 15.

Camera Installation Wizard: If you do not have a mydlink-enabled router, use the Camera Installation Wizard to guide you through setup and initial configuration of your camera. Refer to page 18.

Manual Hardware Installation: This section shows you how to manually set up your camera, though in order to use the mydlink features of your camera, you will still need to run the Camera Installation Wizard. Refer to page 21.

Zero Configuration Setup

If you have a mydlink-enabled Cloud Router, you can take advantage of Zero Configuration. Zero Configuration automatically configures your camera's settings for you, and adds it to your mydlink account automatically. This type of setup allows you to set up your camera by simply plugging it in and connecting it to your router.

Connect your camera to your mydlink-enabled Cloud Router and Zero Configuration will automatically configure your DCS-6045L and automatically add the camera to your mydlink account. After the short time it takes to do this you can remotely access your camera from the www.mydlink.com website to manage and monitor your DCS-6045L.

Connect the PowerLine Adapter

Plug in the PowerLine adapter to a wall outlet. Connect an Ethernet cable from the PowerLine adapter to your existing network.

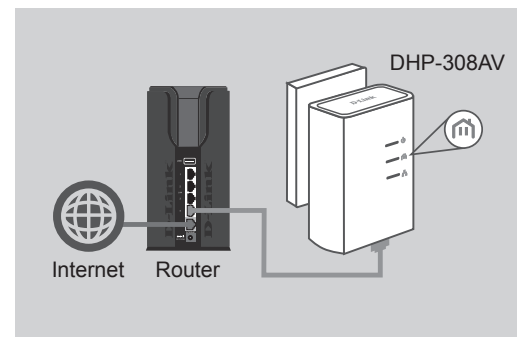

Connect the Camera

Plug in the camera power cord into the DCS-6045L. Move the power switch to the ON position and wait for the PWR, PLC, and LNK to turn green. If you have an existing PowerLine adapter, you will need to press and hold the PLC button on the camera for 5 seconds. After the PLC LED on the camera begins blinking, press the PLC button on your existing PowerLine adapter within the next 60 seconds.

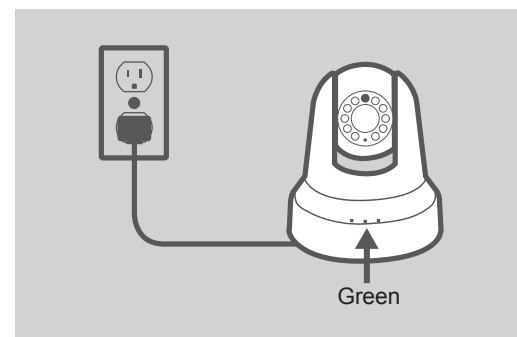

Check Your mydlink Account

Open a web browser and login to your mydlink account. The mydlink page will check for new devices and display a **New Device Found!** pop-up notification in the bottom-left corner. Click the notification to continue.

A summary and confirmation notification will appear with the automatically configured details. Make a note of the details and click **Yes** to add the camera to your account.

The screenshot shows the mydlink web interface for a DIR-605L router. The top navigation bar includes 'My Devices', 'Shared Devices', 'My Services', and 'My Profile'. The main content area is titled 'Router Status' and displays various settings and connection information.

Router Status:

- Model Name: DIR-605L
- Network Name (SSID): Taonet
- Internet IP: 192.168.1.103
- LAN IP: 192.168.0.1
- Connected Devices: 5 device(s)

Connection List:

Device	Device Name	IP Address	MAC Address	Block
	CardboardBox	192.168.0.110	00:26:2D:02:FE:FA	<input type="checkbox"/>
	--	192.168.0.120	04:54:53:50:53:18	<input type="checkbox"/>
	HeiGuy	192.168.0.100	00:1A:92:E2:4D:C9	<input type="checkbox"/>
	--	192.168.0.121	28:E0:2C:DC:0A:BE	<input type="checkbox"/>
	--	192.168.0.101	F9:A2:25:AA:8C:C3	<input type="checkbox"/>

Suspect List:

Device	Device Name	Time	MAC Address	Block
--------	-------------	------	-------------	-------

A 'New Devices!' notification is visible in the bottom-left corner, listing 'DCS-933L'.

Confirming New Device

Do you want to add this new device to your mydlink account?

Device Name: DCS-6045L
mydlink Number: 44441252
Network name (SSID): dddddd
Admin Password: oic953XZ

You can change these default settings by going to **Advanced Settings** after add it to your device list.

Section 2 - Installation

Zero Configuration will navigate to the mydlink Live View tab for your camera where you will see a screen similar to the following.

Your camera is now set up, and you can skip to “mydlink” on page 24 to learn more about the mydlink features of this camera, or to “Configuration” on page 25 for advanced configuration of your camera.

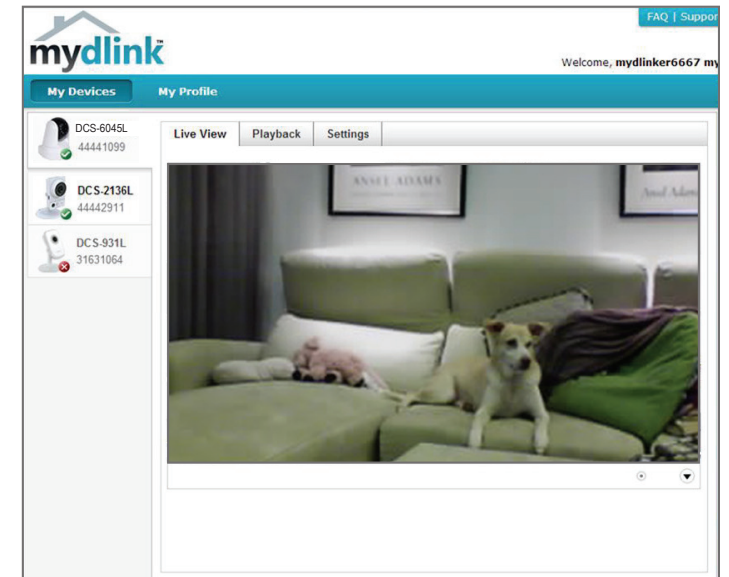

Camera Installation Wizard

Windows Users

Insert the Installation CD-ROM into your computer's optical drive to start the autorun program.

Simply click **Set up your Cloud Camera** to go through the Setup Wizard, which will guide you step-by-step through the installation process from connecting your hardware to configuring your camera and registering it with your mydlink account.

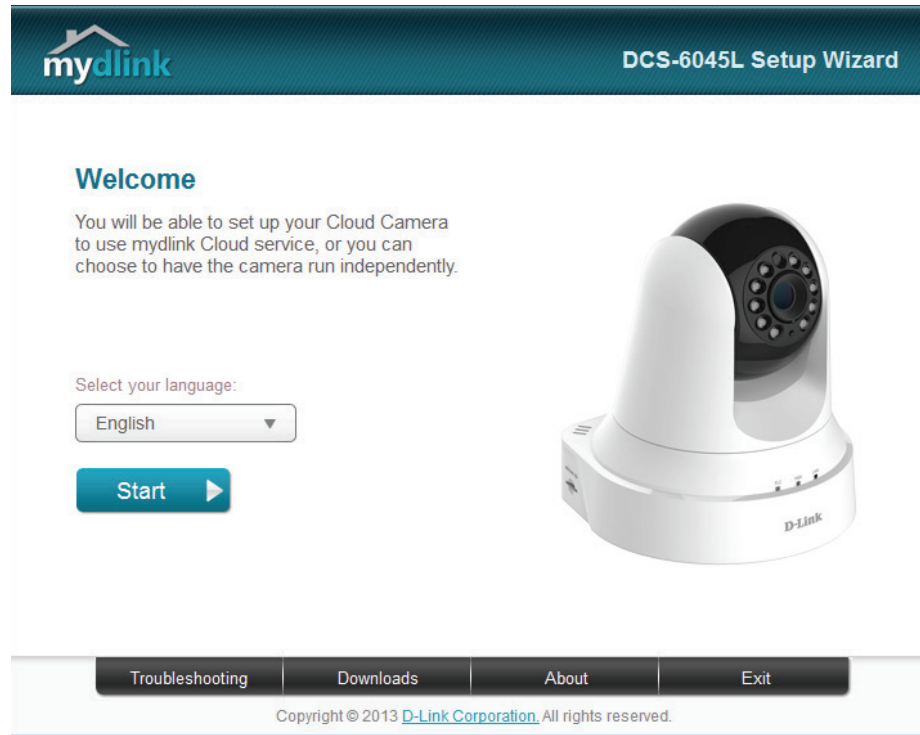

Note: If the autorun program does not open, go to My Computer, browse to your CD drive, and double-click on the autorun.exe file.



Mac Users

Insert the Installation CD-ROM into your computer's optical drive. On the desktop, open your CD drive and double-click on the **SetupWizard** file.



After about 20-30 seconds, the Setup Wizard will open, which will guide you step-by-step through the installation process from connecting your hardware to configuring your camera and registering it with your mydlink account.

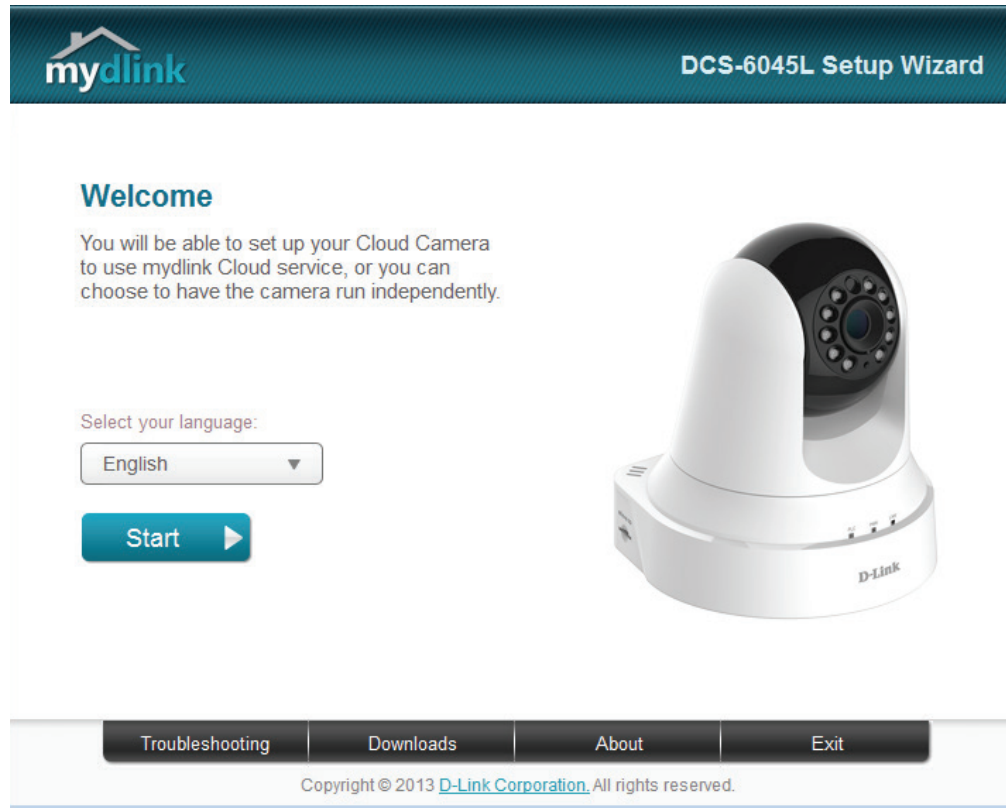

PLC - Push Button Setup

Alternatively, you may create a secure connection using the PLC Sync Button on the back of the camera.

To create a PLC connection:

Step 1

Make sure the camera is plugged in, then press and hold the PLC button for three seconds. The green PLC status LED will start blinking.

Step 2

Press the PLC button on your PowerLine adapter within 60 seconds. The PLC button is usually on the front or side. If you are not sure where the PLC button is on your adapter, please refer to your adapter User Manual.

The DCS-6045L will automatically create a secure connection to your PowerLine adapter. While connecting, the green LED will flash and your camera will reboot.

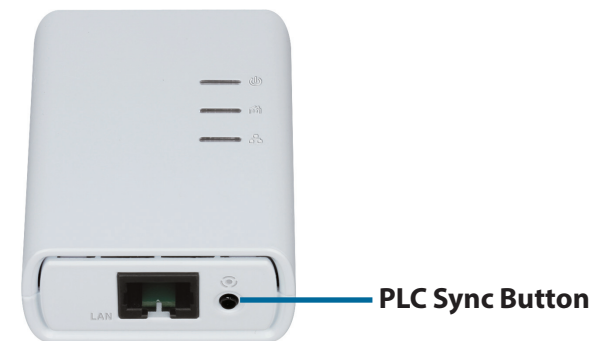

Manual Hardware Installation

If you wish to set up your camera without using the Camera Setup Wizard, please follow these steps.

Note: In order to use the mydlink features of this product, you will need to go through the Camera Setup Wizard or Zero Configuration Setup.

Connect the Camera

Plug in the camera power cord into the DCS-6045L. Move the power switch to the ON position and wait for the PWR, PLC, and LNK to turn green. If you have an existing PowerLine adapter, you will need to press and hold the PLC button on the camera for 5 seconds. After the PLC LED on the camera begins blinking, press the PLC button on your existing PowerLine adapter within the next 60 seconds.

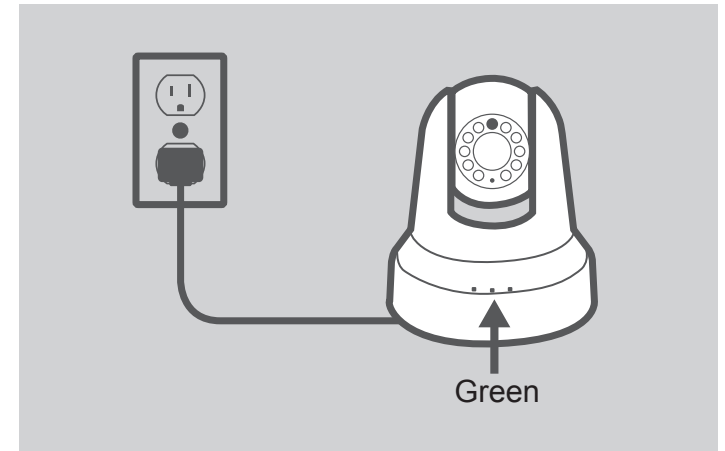

Configure Your Camera

Refer to “Configuration” on page 25 for information on how to configure your camera.

Use PLC to Connect

You can use PLC to connect your camera to your PowerLine adapter. For more information, refer to “PLC - Push Button Setup” on page 20.

Mounting The Camera

Please refer to the steps below to assist you with mounting the camera. We suggest that you configure the camera before mounting.

Step 1:

Place the mounting bracket where you want to position the camera and use a pencil to mark the holes.

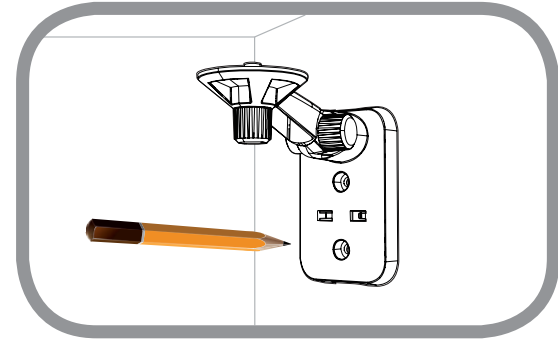

Step 2:

Depending on the material of the wall or ceiling, use proper tools to drill two holes or screws where you placed the mounting sticker. If the wall is made out of concrete, drill the holes first, insert the plastic anchors and then the screws. The space between the camera and the screwheads should be 3 mm.

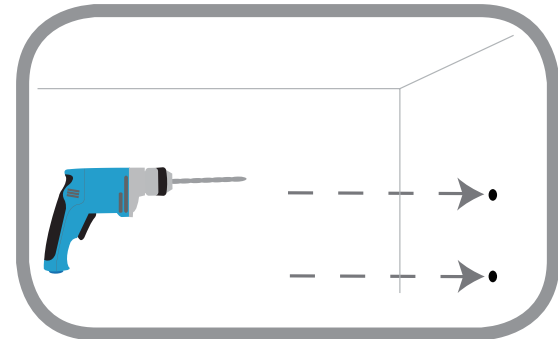

Step 3:

If desired, the camera power cord can be concealed behind the mounting bracket. Run the cable through the back of the mounting bracket, securing it with the built-in guides. Be sure to leave enough cable length protruding from the top to allow connection to the camera.

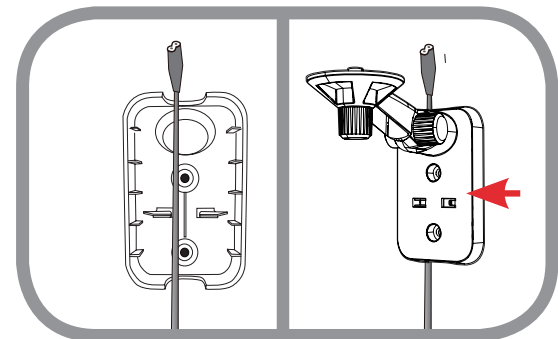

Step 4:

Fasten the mounting bracket to the wall using the screws provided.

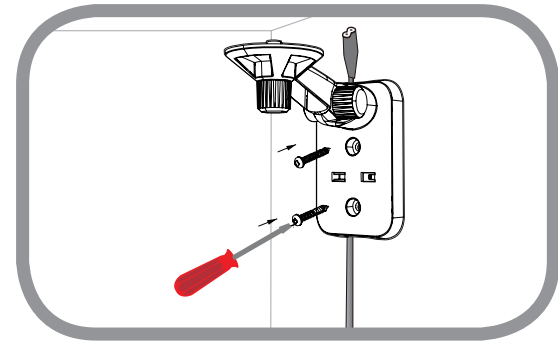

Step 5:

Using the supplied thumbscrew, fasten the camera to the mounting bracket. Connect the camera power cord to the camera.

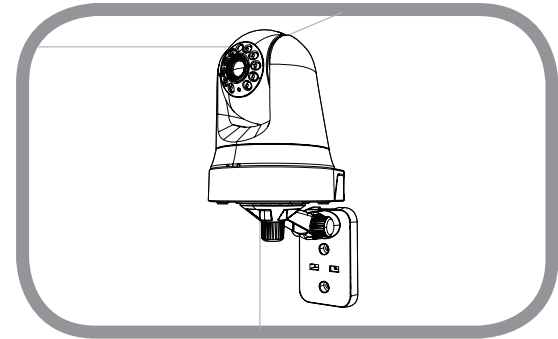

Step 6:

Adjust the angle of the arm on the mounting bracket as required. Tighten the thumbscrew to lock the arm in place.

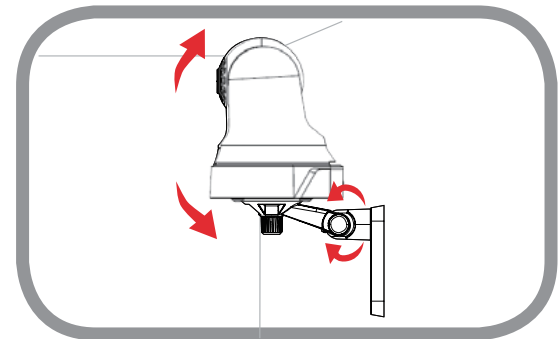

mydlink

After registering your DCS-6045L camera with a mydlink account in the Camera Installation Wizard, you will be able to remotely access your camera from the www.mydlink.com website. After signing in to your mydlink account, you will see a screen similar to the following:

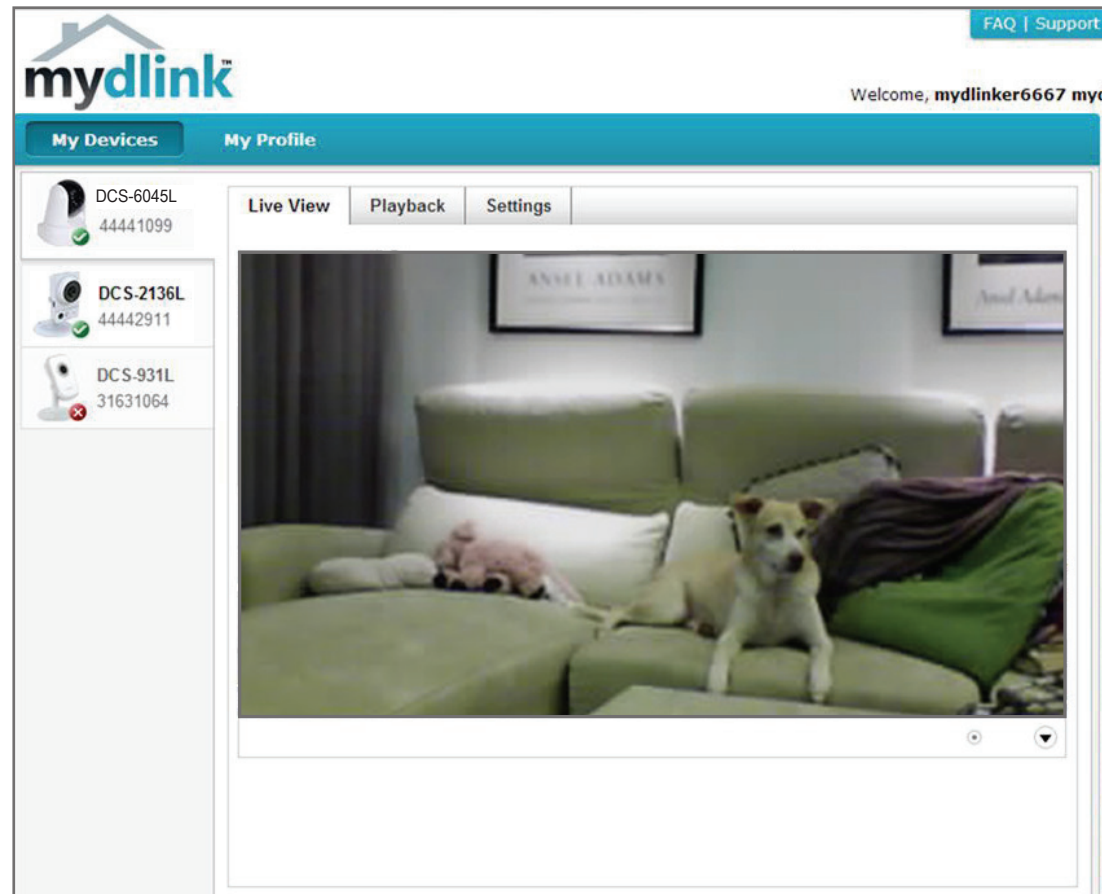

For more details on using your camera with mydlink, go to the **Support** section of the mydlink website and check the **User Manual** section for your product to find the latest instruction guide for your camera's mydlink features.

Configuration

Using the Web Configuration Interface

After completing the Camera Installation Wizard, you are ready to use your camera. The camera's built-in Web configuration interface is designed to allow you to easily access and configure your DCS-6045L. At the end of the wizard, enter the IP address of your camera into a web browser, such as Internet Explorer®. To log in, use the User name **admin** and the password you created in the Installation Wizard. If you did not create a password, the default password is blank. After entering your password, click **OK**.

Note: If you are directly connecting your PC to the camera, or if you are using the camera on a closed network, the default IP is **192.168.0.20**.

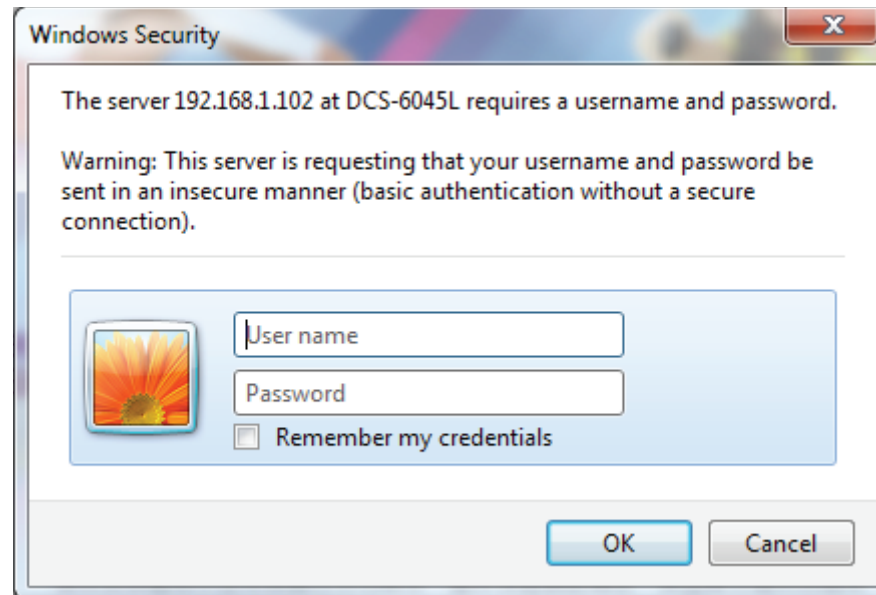

Live Video

The Live Video screen shows you the live video feed from your camera. For information on how to configure your Live Video streams, refer to “Audio and Video” on page 33.

Video Compression Format: Click the **H.264** or **MJPEG** radio button to choose which stream to view.

Zoom: Click on these buttons to zoom in and out of the video.

Audio: Click on these buttons to turn audio playback on and off.



Setup Wizard

You may choose to configure your network by using the **Internet Connection Setup Wizard** that includes step-by-step instructions. Otherwise, you may manually configure your connection using the **Manual Internet Connection Setup**.

Note: To register your camera with mydlink and enable its mydlink-related features, you will need to use the Camera Installation Wizard. Please refer to “Camera Installation Wizard” on page 18 for more details.

INTERNET CONNECTION SETTINGS

In this section, you can setup the IP camera's network interface settings. If you are configuring this device for the first time, D-Link recommends that you click the Internet Connection Setup Wizard button, and follow the instructions on screen. If you wish to modify or configure the IP camera settings manually, click the Manual Internet Connection Setup button.

Internet Connection Setup Wizard

Manual Internet Connection Setup

Internet Connection Setup Wizard

This wizard will guide you through a step-by-step process to configure your new D-Link Camera and connect the camera to the Internet.

Click **Next** to continue.



Select what kind of Internet connection your camera should use:

- **DHCP Connection (Default):** If you are connected to a router, or are not sure which connection to use, select DHCP Connection.
- **Static IP Address:** This will allow you to manually enter your network settings for the camera. If you are not sure what settings to enter, check with your Internet service provider or network administrator.
- **PPPoE Connection:** If your camera is directly connected to a DSL modem, you may need to use PPPoE. Enter the username and password provided to you by your Internet service provider.

Click **Next** to continue.

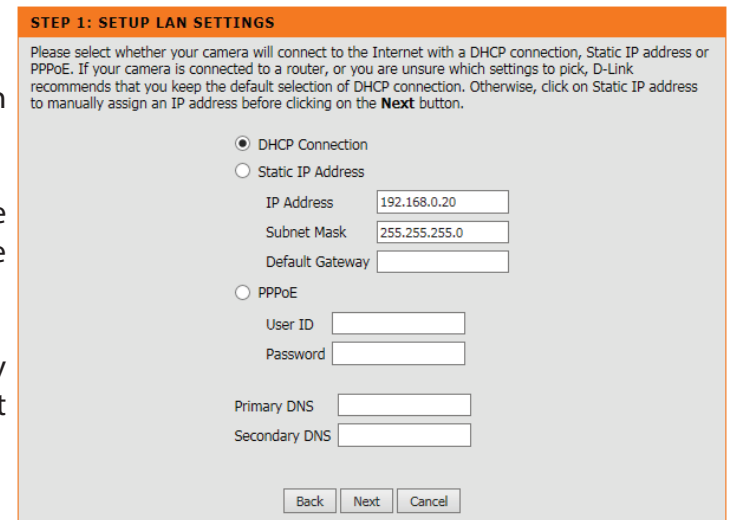

Section 3 - Configuration

If you have a Dynamic DNS account and would like the camera to update your IP address automatically, select **Enable** and enter your host information. Otherwise, simply select **Disable**.

Click **Next** to continue.

Enter a name for your camera. Click **Next** to continue.

Select the correct time zone to ensure that all events are triggered, captured, and scheduled at the right time. Click **Next** to continue.

This page displays your configured settings. Click **Apply** to save and activate your changes, or click **Back** to change your settings.

STEP 2: SETUP DDNS SETTINGS

If you have a Dynamic DNS account and would like your camera to update the IP address automatically, enable DDNS and enter your host information below. Click on the **Next** button to continue.

Enable
 Disable

Server Address << Select Dynamic DNS Server ▾

Host Name

User Name

Password

Timeout hours

Back Next Cancel

STEP 3: SERVER NAME SETTINGS

D-Link recommends that you rename your camera for easy accessibility. Please assign a name of your choice before clicking on the **Next** button.

Camera Name

Back Next Cancel

STEP 4: SETUP TIME ZONE

Please select the camera's timezone and then click on the **Next** button.

Current Time 06 Jan 2014 1:30:41 A.M.
Time Zone ▾

Back Next Cancel

STEP 5: SETUP COMPLETE

Here is a summary of your camera settings. Click **Back** to modify the settings, or click **Apply** if all settings are correct. It is recommended you write down this information for future access or reference.

IP Address	DHCP Connection
IP Camera Name	DCS-6045L
Time Zone	(GMT-12:00) International Date Line West
DDNS	Disable

Back Apply Cancel

Network Setup

This section allows you to configure your network settings.

DHCP Connection: Select this connection if you have a DHCP server running on your network and would like a dynamic IP address to be updated to your camera automatically.

Static IP Address: You may obtain a static or fixed IP address and other network information from your network administrator for your camera. A static IP address will ease you for accessing your camera in the future.

IP Address: The fixed IP address

Subnet Mask: The default value is "255.255.255.0." Used to determine if the destination is the same subnet.

Default Gateway: The gateway used to forward frames to destinations in a different subnet. Invalid gateway settings may cause the failure of transmissions to a different subnet.

Primary DNS: Primary domain name server that translates names to IP addresses.

Secondary DNS: Secondary domain name server to backup the Primary DNS.

PPPoE Settings: If you are using a PPPoE connection, enable it and enter the User Name and Password for your PPPoE account. You can get this information from your Internet service provider (ISP).

Port Settings: You may configure a Second HTTP port that will allow you to connect to the camera via a standard web browser. The port can be set to a number other than the default TCP ports 80. A corresponding port must be opened on the router. For example, if the port is changed to 1010, users must type **http://192.168.0.100:1010** instead of only "http://192.168.0.100".

UPnP Settings: Enable this setting to configure your camera as a UPnP device in the network.

Bonjour: You can enable or disable Bonjour services. Bonjour provides a simple way of sharing services on your camera to other clients on your network.

Bonjour Name: Enter a name that will be used with Bonjour to help identify your camera.

NETWORK

You can configure your LAN and Internet settings here.

LAN SETTINGS

DHCP Connection
 Static IP Address
 PPPoE

IP Address
 User ID

Subnet Mask
 Password

Default Gateway

Primary DNS

Secondary DNS

PORT SETTINGS

HTTP Port

UPnP SETTINGS

UPnP Enable Disable

UPnP Port Forwarding Enable Disable

BONJOUR SETTINGS

Bonjour Enable Disable

Bonjour Name

(Characters you may use in a Bonjour Name: "upper or lower case letters", "numbers" and "hyphens".)

DDNS

This section allows you to configure the DDNS setting for your camera. DDNS will allow all users to access your camera using a domain name instead of an IP address.

Enable/Disable: Click to enable or disable the DDNS function.

Server Address: Select your Dynamic DNS Server from the pull down menu.

Host Name: Enter the host name of the DDNS server.

User Name: Enter your username or e-mail used to connect to the DDNS.

Password: Enter your password used to connect to the DDNS server.

Timeout: You can set a refresh timeout by entering the number of hours before the current DDNS session will expire.

The screenshot displays the DDNS configuration interface. At the top, there is an orange header labeled "DYNAMIC DNS". Below this header, a text box explains the feature: "The Dynamic DNS feature allows you to host a server (Web, FTP, Camera, etc...) using a domain name that you have purchased (www.whateveryournameis.com) from your broadband Internet Service Provider (ISP). Using a DDNS service, your friends can enter your host name to connect to your IP Camera regardless of your IP address." Below the text are two buttons: "Save Settings" and "Don't Save Settings".

Below the orange header is a dark grey header labeled "DYNAMIC DNS SETTINGS". Underneath, there are two radio buttons: "Enable" (unselected) and "Disable" (selected). The "Server Address" field is a text input followed by a dropdown menu labeled "Select Dynamic DNS Server" with a double less-than sign icon. Below this are four more text input fields: "Host Name", "User Name", "Password", and "Timeout". The "Timeout" field contains the value "576" and is followed by the text "hours". At the bottom of the settings section are two buttons: "Save Settings" and "Don't Save Settings".

Image Setup

This section allows you to configure the image settings for your camera.

Enable Anti Flicker: If you have lights flickering in your camera video, try enabling anti flicker. Otherwise, you should leave this disabled.

Flip Image: Select this box to vertically flip the video.

Mirror: Horizontally flip the video.

Note: If the camera is installed upside down, **Flip Image** and **Mirror** should both be checked

Brightness Control: Allows you to adjust the brightness level.

Contrast Control: Allows you to adjust the contrast level.

Saturation Control: Allows you to adjust the saturation level.

Light Frequency: Select the frequency used by your lighting and power to help reduce image flicker.

IMAGE SETUP

In this section, you can configure the image settings for your camera.

IMAGE SETTINGS

Enable Anti Flicker	<input type="checkbox"/>
Flip Image	<input type="checkbox"/>
Mirror	<input type="checkbox"/>
Brightness Control	+0 ▼
Contrast Control	+0 ▼
Saturation Control	+0 ▼
Light Frequency	<input type="radio"/> 50 Hz <input checked="" type="radio"/> 60 Hz

Audio and Video

This section allows you to configure the audio and video settings for your camera.

Note: Please wait a few seconds for the camera to adjust the audio after making changes.

Video Profile: This section allows you to change the **Resolution**, **FPS**, and **Quality**.

Encode Type: Your camera has separate settings for the H.264 and MJPEG video streams.

Resolution: Select the desired video resolution from three formats: 1280 x 720, 640 x 480, and 320 x 240.

Bit Rate: Higher settings offer better quality, but will require more bandwidth to stream.

Frame Rate: Select the frame rate(FPS) to use for the video stream. Higher settings offer better quality, but will require more bandwidth to stream.

JPEG Quality: Select one of five levels of image quality: **Highest**, **High**, **Medium**, **Low**, and **Lowest**.

Default View Mode: Select the default encoding to use when viewing your video on the **Live Video Mode** page.

Day/Night Mode: If **Auto** is selected, the camera will automatically switch between day and night mode. If **Manual** is selected, you can select **Day Mode** or **Night Mode** from the **Live Video** page. **Always Day Mode** or **Always Night Mode** will cause the camera to only operate in that mode. **Day Mode Schedule** will allow you to specify periods of time when the camera should be in **Day Mode**, otherwise it will operate in **Night Mode**.

Microphone: You can enable or disable the onboard camera microphone by checking this option.

Volume: If the microphone option is enabled, you can set the volume of the microphone by selecting an option from the dropdown menu.

AUDIO AND VIDEO

In this section, you can configure the video quality, resolution, frame rate, day/night mode and audio settings for your camera.

VIDEO PROFILE

Encode Type	Resolution	Bit Rate	Frame Rate
H.264	640 x 480 ▼	2 Mbps ▼	30 ▼
Encode Type	Resolution	Jpeg Quality	Frame Rate
MJPEG	640 x 480 ▼	Medium ▼	Auto ▼

Default View Mode : H.264 ▼

DAY/NIGHT MODE

Day/Night Mode Auto ▼

AUDIO SETUP

Microphone

Volume 80 ▼

Time and Date

This section allows you to configure the settings of the internal system clocks for your camera.

Time Zone: Select the time zone for your region from the drop down menu.

Synchronize NTP Server: Enabling this will allow the camera to update its clock automatically from an NTP server. Select the NTP server closest to you, and select whether you want to apply daylight saving corrections.

Set the Date and Time Manually: If Synchronize NTP Server is disabled, you can set the date and time manually. You can also click on the **Copy Your Computer's Time Settings** to automatically set the date and time based on your computer's settings.

TIME AND DATE

The Time Configuration option allows you to configure, update, and maintain the internal system clock. In this section you can set the time zone the camera is in, and set the NTP (Network Time Protocol) Server.

TIME CONFIGURATION

Current Time 06 Jan 2014 1:29:21 A.M.
 Time Zone (GMT-12:00) International Date Line West ▼

AUTOMATIC TIME CONFIGURATION

Synchronize NTP Server

NTP Server Used << Select NTP Server ▼

Daylight Saving Enable Disable

Offset : +1:00 ▼

	Month	Week	Day of Week	Time
Start	Jan ▼	1st ▼	Sun ▼	12 am ▼
End	Jan ▼	1st ▼	Sun ▼	12 am ▼

SET THE DATE AND TIME MANUALLY

Year	2014 ▼	Month	1 ▼	Day	6 ▼
Hour	1 ▼	Minute	29 ▼	Second	20 ▼

Mail

This section allows you to configure your camera to send snapshots and video clips to an e-mail address. If you are not sure what settings to use, check with your e-mail service provider.

SMTP Server Address: This is the domain name or IP address of your external e-mail server.

SMTP Server Port: If your e-mail server uses a non-standard port, you can enter it here.

Sender e-mail Address: This is the e-mail address listed as the sender for your notification e-mails.

Receiver e-mail Address: This is the e-mail address that your notification e-mails will be sent to.

User Name: If the SMTP server uses authentication, enter your user name.

Password: If the SMTP server uses authentication, enter your password.

Use SSL-TLS/STARTTLS: If your e-mail server requires a secure authentication connection, you can select the type of authentication by choosing either **SSL-TLS** or **STARTTLS**.

MAIL

This section allows you to setup and configure the email notification settings for your camera. If your details change or you are experiencing issues with alert notifications, you may need to modify these settings.

E-MAIL ACCOUNT

SMTP Server Address

SMTP Server Port (Default is 25)

Sender E-mail Address

Receiver E-mail Address

User Name

Password

Use SSL-TLS/STARTTLS No SSL-TLS STARTTLS

Enable the e-mailing of images to an e-mail account:

Enabling this will allow snapshots to be e-mailed to you in different ways:

- Choosing **Always** will e-mail snapshots continuously based on the **E-mail Interval** specified.
- Choosing **Schedule** will allow you to schedule when to start and stop the e-mailing of snapshots.
- Select **Motion/Sound Detection** if you would like the camera to e-mail images only when motion or sound is detected. You can choose whether to e-mail a snapshot immediately, or e-mail 6 snapshots together, with 3 frames before and after motion/sound was detected. You can also set the **Frame interval time** to specify how far apart the snapshots should be.

E-mail Interval:

This sets the limit for how frequently e-mail notifications will be sent. This can be set from 1 to 65535 seconds.

Enable the e-mailing of video clips to an e-mail account:

Enabling this will allow video clips to be e-mailed to you in different ways. This is the same as e-mailing images, as specified above, but will take video clips according to the **Video Limit** settings you specify.

Test E-mail Account:

This will send a test e-mail according to the e-mail settings you have specified above.

TIME SCHEDULE

Enable the emailing of images to an email account

Always

Schedule
 Day Mon Tue Wed Thu Fri Sat Sun
 Time Period Start : 00:00:00 (Example : 06:30:00)
 Stop : 00:00:00 (Example : 22:30:00)

Motion/Sound Detection
 E-mail frame immediately
 E-mail attached with 6 frames (3 frames before and 3 frames after detection)
 Frame interval time : 1 second

E-mail Interval Seconds

Enable the emailing of video clip to an email account

Always

Schedule
 Day Mon Tue Wed Thu Fri Sat Sun
 Time Period Start : 00:00:00 (Example : 06:30:00)
 Stop : 00:00:00 (Example : 22:30:00)

Motion/Sound Detection

E-mail Interval Seconds

Video Limit : Size KBytes (max is 3072 KBytes)
 Time Seconds (max is 15 Seconds)

TEST E-MAIL ACCOUNT

A test e-mail will be sent to the e-mail account listed above.

FTP

This section allows you to configure your camera to send snapshots and video clips to an FTP server.

Host Name: Enter the IP address of the FTP server that you will be connecting to.

Port: Enter the port of the FTP server that you will be connecting to.

User Name: Enter the user name of your FTP server account.

Password: Enter the password of your FTP server account.

Path: Enter the destination path/folder to save files to on the FTP server.

Passive Mode: Enabling passive mode may help you reach your FTP server if your camera is behind a router protected by a firewall.

Enable the uploading of images to an FTP server: Enabling this will allow snapshots to be uploaded in different ways:

- Choosing **Always** will upload snapshots continuously based on the **Image Frequency** specified.
- Choosing **Schedule** will allow you to schedule when to start and stop the uploading of snapshots.
- Select **Motion/Sound Detection** if you would like the camera to upload images only when motion or sound is detected.

Image Frequency: Set how frequently you want images to be taken and uploaded. You can choose to upload by frames per second, or by seconds per frame.

Base File Name: Set what you want the base file name to be for your snapshots.

FTP

In this section, you can configure the camera to send images to an FTP server.

Save Settings Don't Save Settings

FTP SERVER

Host Name

Port (Default is 21)

User Name

Password

Path

Passive Mode Yes No

TIME SCHEDULE

Enable uploading of images to an FTP server

Always

Schedule

Day Mon Tue Wed Thu Fri Sat Sun

Time Period Start : (Example : 06:30:00)

Stop : (Example : 22:30:00)

Motion/Sound Detection

Image Frequency 1 Frames/Second

1 Seconds/Frame

Base File Name

File: Select how you want uploading of snapshots to be handled:

- **Overwrite** will replace the old snapshot with the new one. This means you will only have one snapshot that is updated every time a new one is taken.
- **Date/Time Suffix** will add the date and time to the end of the snapshot file name. You can also choose to make subfolders based on a period of time you specify to help you organize your snapshots.
- **Sequence Number Suffix** will add a number to the end of the snapshot file name up to the number you specify, after which the oldest files will be overwritten.

Test FTP Server: Clicking on the **Test** button will send a test JPEG snapshot to the FTP server specified above to make sure that your settings are correct.

This will send a test e-mail according to the e-mail settings you have specified above.

The screenshot shows the configuration page for the D-Link DCS-6045L camera. The 'File' section is active, showing options for 'Overwrite', 'Date/Time Suffix', and 'Sequence Number Suffix Up to 1024'. The 'Date/Time Suffix' option is selected. Below this, there is a checkbox for 'Enable uploading of video clip to an FTP server', which is currently unchecked. Underneath, there are three radio button options: 'Always' (selected), 'Schedule', and 'Motion/Sound Detection'. The 'Schedule' option is expanded to show a 'Day' selection (all days are unchecked) and a 'Time Period' with 'Start' and 'Stop' time fields. Below the schedule options, there is a 'File Name Prefix' field containing 'DCS-6045L'. The 'Video Limit' section shows 'Size' set to 2048 KBytes (max is 3072 KBytes) and 'Time' set to 10 Seconds (max is 15 Seconds). At the bottom of the configuration area, there is a 'TEST FTP SERVER' section with a message: 'A JPEG file will be sent to the above FTP server for testing. (File name: test_date_time.jpg)'. A 'Test' button is located to the right of this message. At the very bottom of the page, there are two buttons: 'Save Settings' and 'Don't Save Settings'.

SD Recording

This option allows you to configure and set a schedule for the recording feature of the camera to the local SD Card.

Enable recording of images to SD card: Check this box to enable the recording feature for images.

Trigger by: Select whether the event is activated by **Motion, Schedule**, or if the video is **Always** recording.

Always: This will enable continuous recording to the SD card.

Schedule: Click day and time for SD recording during a specified time.

Motion/Sound Detection: Enables SD recording after motion or sound is detected.

Recording Interval: You can set the interval of time in seconds the camera will wait for taking snapshots when it is recording.

SD Card: You can set how much free space to keep in SD card and if recording should be done cyclically or not.

Keep Free Space: Set the capacity of your local SD Card to prevent the system from becoming unstable.

Cyclic: When this option is selected, it will cause the oldest image files to be deleted when the system requires storage space for new image files.

Click **Save Settings** to save your changes.

SD RECORDING

In this section, you can configure the camera to record the image/video to the SD card.

TIME SCHEDULE

Enable recording of images to SD card

Always

Schedule

Day Mon Tue Wed Thu Fri Sat Sun

Time Period Start : (Example : 06:30:00)

Stop : (Example : 22:30:00)

Motion/Sound Detection

Recording Interval Seconds

SD Card : Keep Free Space MB (Minimum is 200)

Cyclic

Section 3 - Configuration

Enable recording of video clip to SD card: Check this box to enable the recording feature for video.

Trigger by: Select whether the event is activated by **Motion**, **Schedule**, or if the video is **Always** recording.

Always: This will enable continuous recording to the SD card.

Schedule: Click day and time for SD recording during a specified time.

Motion/Sound Detection: Enables SD recording after motion or sound is detected.

File Format: You can select recording type for video. Video profile options are found under the Audio and Video setup tab).

Recording Length: You can set the recording time in minutes per file by selecting an option from the dropdown menu. The camera will create individual files of the selected length anytime the camera is actively recording.

SD Card: You can set how much free space to keep in SD card and if recording should be done cyclically or not.

Keep Free Space: Set the capacity of your local SD Card to prevent the system from becoming unstable.

Cyclic: When this option is selected, it will cause the oldest snapshot/video files to be deleted when the system requires storage space for new snapshot/video files.

Test SD Card: You can test the the SD card by clicking on the **Test** button. This will write a small file to the card.

Click **Save Settings** to save your changes.

The screenshot shows a configuration window for SD card recording. At the top, there is a checkbox labeled "Enable recording of video clip to SD card". Below this, there are three radio button options: "Always" (selected), "Schedule", and "Motion/Sound Detection". The "Schedule" option is expanded to show a "Day" selection with checkboxes for Mon, Tue, Wed, Thu, Fri, Sat, and Sun. Below the day selection, there are "Time Period" fields for "Start" and "Stop", each with a time input field and an example (e.g., "06:30:00"). The "Motion/Sound Detection" option is also expanded to show a "File Format" dropdown menu set to "AVI", a "Recording Length" dropdown menu set to "5" minutes per file, and an "SD Card" section with a "Keep Free Space" input field set to "200" MB (with a note "Minimum is 200") and a "Cyclic" checkbox. At the bottom of the configuration area, there is a "TEST SD CARD" section with a text box stating "A test file will be written to SD card and read back to test SD card." and a "Test" button. Below the configuration area, there are two buttons: "Save Settings" and "Don't Save Settings".

Motion Detection

Motion detection allows you to mark areas of your camera's video to monitor for motion, which can be used to trigger snapshots or recordings. Refer to "Mail" on page 35 and "FTP" on page 37 for more details.

Motion Detection: Select whether you want to enable or disable the motion detection feature of your camera.

Time: Specify whether you want to **Always** have motion detection enabled, or according to a **Schedule** that you define.

Sensitivity: Specify the amount of difference required to determine whether there was motion.

Detection Areas: Use your mouse to click on the areas of the video that you would like to monitor for motion.

MOTION DETECTION

In this section, you can configure the motion detection settings for your camera.

Please note that your computer needs to have Java installed in order to view the motion detection configuration window. If you do not see the live video below, please visit <http://www.java.com> to download and install Java.

MOTION DETECTION SETTINGS

Motion Detection Enable Disable

Time

Always
 Schedule

Mon Tue Wed Thu Fri Sat Sun

Time Period Start : 00:00:00 (Example : 06:30:00)
 Stop : 00:00:00 (Example : 22:30:00)

Sensitivity % (0~100%, high sensitivity makes the motions easier to be detected.)

Detection Areas Use mouse to click the blocks where you want to monitor for motion.

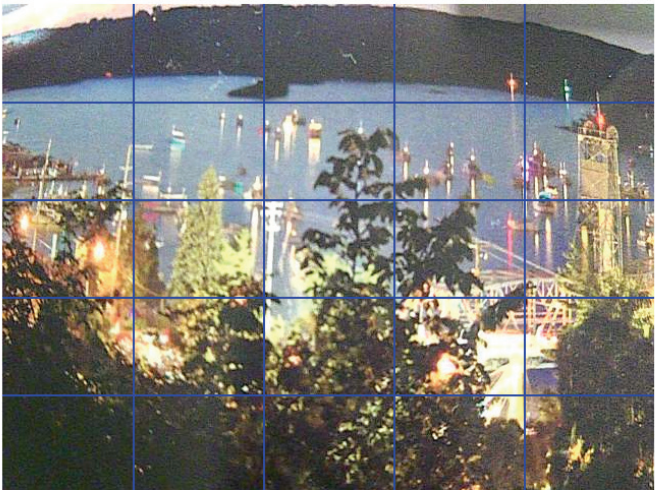

Sound Detection

Sound detection allows you to detect when there is a loud sound in the area, which can be used to trigger snapshots or recordings. Refer to “Mail” on page 35 and “FTP” on page 37 for more details.

Sound Detection: Select whether you want to enable or disable the sound detection feature of your camera.

Time: Specify whether you want to **Always** have motion detection enabled, or according to a **Schedule** that you define.

Detection Level: Specify the volume level that a sound must exceed in order to be “detected”.

SOUND DETECTION

In this section, you can configure the sound detection settings for your camera.

Please note that your computer needs to have Java installed in order to view the sound dB/Time window. If you do not see the sound dB/Time window below, please visit <http://www.java.com> to download and install Java.

SOUND DETECTION SETTINGS

Sound Detection Enable Disable

Time Always

Schedule

Day Mon Tue Wed Thu Fri Sat Sun

Time Period Start : 00:00:00 (Example : 06:30:00)
Stop : 00:00:00 (Example : 22:30:00)

Detection Level 90 dB

Time

SD Management

Here you may browse and manage the recorded files which are stored on the SD card.

If your SD card is not available or not formatted correctly, your camera will not list any pictures or videos, or display "SD Status : Not Ready". If you insert a new SD card, you may need to reboot the camera in order for it to recognize the newly inserted media.

View Recorded If the picture files are stored on the SD card, click on the Picture link and **Picture:** choose the picture file you would like to view.

Playback If video files are stored on the SD card, click on the Video link and choose **Recorded Video:** the video file you would like to view.

Refresh: Reloads the file and folder information from the SD card.

Format SD Card: Click this icon to automatically format the SD card and create "picture" & "video" folders.

The screenshot displays the 'SD MANAGEMENT' interface. At the top, there is an orange header with the text 'SD MANAGEMENT'. Below this, a grey box contains the instruction: 'In this section, you could browse and manage the record files which stored in the SD card.' The main content area has a dark grey header with 'SD MANAGEMENT' in white. Below the header, it shows 'SD Card DCS-6045L /' and 'SD Status : Not Ready'. There are controls for 'Files per Page: 25' with a dropdown arrow and a 'Refresh' link, and 'Pages: 1 of 1' with a dropdown arrow. A table with columns 'Name' and 'Size' is visible, with a 'Delete' checkbox to its left. At the bottom left is a 'Format SD card' button, and at the bottom right is the text 'Total : 0 KB, Used : 0 KB, Free : 0 KB'.

Maintenance

Admin

This section allows you to change the administrator's password and configure the server settings for your camera. You can also manage the user account(s) that are allowed to access to your camera.

Admin Password Setting: To change the admin password used to log into the web interface, enter the old password, then enter the new password and retype it in the next text box, then click **Apply**.

Camera Name: Specify a name for your camera

LED Control: Select **Normal** to enable the LED on the front of the device, or select **Off** to disable the LED. Turning this off may be useful if you do not want the camera to be noticeable.

User Access Control: Select **Enable** to enable user access control or **Disable** to allow only the administrator account to access the camera.

Snapshot URL Authentication: Select **Enable** to allow access to the current camera snapshot via the web address indicated.

OSD Time: Select **Enable** to allow the current time to be added to the camera video, and select a color to use for the text.

Add User Account: You can create new users to provide viewing access for your camera's video. User accounts will only be able to access the **Live Video** section of the web configuration interface, but cannot access any other parts or change any settings.

To create a new user, enter a user name, password, and retype the password, then click **Add**. A maximum of 8 user accounts can be created.

User List: Displays the account names of authorized users. You can modify or delete an account by clicking on its modify or delete icon.

ADMIN

Here you can change the administrator's password and configure the server setting for your camera. You can also add, modify and/or delete the user account(s).

ADMIN PASSWORD SETTING

Old Password

New Password

Retype Password

SERVER SETTING

Camera Name

LED Control Normal Off

User Access Control Enable Disable

Snapshot URL Authentication Enable Disable (http://192.168.1.102/image/jpeg.cgi)

OSD Time Enable Disable

Color

ADD USER ACCOUNT

User Name

Password

Retype Password

USER LIST

no.	name	modify	delete

System

This section allows you to save and restore your configuration, restore the factory settings, and/or restart the camera.

Save To Local Hard Drive: Click the **Save Configuration** button to save the current camera configuration to your local PC.

Load From Local Hard Drive: To load a previously saved configuration, click the **Browse...** button, select your saved configuration file, then click the **Restore Configuration From File** button.

Restore To Factory Default: Click the **Restore Factory Defaults** button to reset all settings back to the factory defaults. Please note that this will erase any changes you have made to the settings of the camera.

Reboot The Device: Click the **Reboot the Device** button to reboot the camera.

The screenshot shows a web interface for the SYSTEM configuration. It features a header bar with the word "SYSTEM" in white on an orange background. Below the header, a light gray box contains the text: "Here you can save and restore your configuration, restore the factory settings, and/or restart the camera." The main content area has a dark gray header with "SYSTEM" in white. Below this, there are four rows of controls:

- Save To Local Hard Drive:** A button labeled "Save Configuration".
- Load From Local Hard Drive:** A text input field followed by a "Browse..." button, and a button labeled "Restore Configuration From File".
- Restore To Factory Default:** A button labeled "Restore Factory Defaults".
- Reboot The Device:** A button labeled "Reboot the Device".

Firmware Upgrade

Your current firmware version and date will be displayed on your screen. You may go to the [D-Link Support Page](#) to check for the latest firmware versions available.

To upgrade the firmware on your DCS-6045L, download the latest firmware from the D-Link Support Page to your local hard drive. Click the **Browse...** button and select the firmware file, then click the **Upload** button to start the firmware upgrade.

Warning: The firmware upgrade process must not be interrupted or the camera may be damaged. When upgrading firmware, do not unplug the camera or your PC or close your web browser until the process is complete. It is also highly recommended that you use a wired connection for your camera and PC when upgrading firmware.

The screenshot displays a web interface for firmware management. It features three main sections: a notification for a new firmware upgrade, a table of current system information, and a file upload area.

FIRMWARE INFORMATION	
Current Firmware Version :	0.99
Current Firmware Date :	2013-12-23
Current Agent Version :	2.0.17-b40

The upload section includes a text input field for the file path, a 'Browse...' button to select a file, and an 'Upload' button to initiate the process.

Status

Device Info

This section displays all the detailed information about your device and network settings.

DEVICE INFO

All of your network connection details are displayed on this page. The firmware version is also displayed here.

BASIC INFORMATION

Camera Name	DCS-6045L
Time & Date	06 Jan 2014 1:30:16 A.M.
Firmware Version	0.99 (2013-12-23)
Agent Version	2.0.17-b40
MAC Address	00 FF 00 65 89 01
IP Address	192.168.1.102
Subnet Mask	255.255.255.0
Default Gateway	192.168.1.1
Primary DNS	192.168.1.1
Secondary DNS	0.0.0.0
DDNS	Disable
UPnP Port Forwarding	Disable
FTP Server Test	No test conducted.
E-mail Test	No test conducted.

Refresh

Active User

This page lists all the active users' information including the User Name, IP address, and the time that camera access began.

ACTIVE USER

This page lists active user information, including user name, IP address and the initial access time.

USER LIST

no.	user name	IP address	time
-----	-----------	------------	------

Refresh

Troubleshooting

1. What is Remote Access? How do I enable it?

Remote Access allows you to access your camera from any PC connected to the Internet through a web browser. This lets you view your camera feed and manage your camera's settings when you're away from home.

To enable Remote Access, simply go through the Camera Installation Wizard included on the Installation CD that came in your package.

After going through the wizard, you should see Remote Status: Enabled on the summary page.

If you see Remote Status: Disabled, make sure that:

- ...the front LED on your camera is lit solid green

- ...your Internet connection is working

- ...your router's LAN & WAN connections are working properly

- ...your router has UPnP enabled (if your router does not support UPnP, please refer to Appendix A)

- ...your router can get a public IP

- ...your router is upgraded to the latest firmware

- ...you have tried rebooting your router by unplugging it, then plugging it back in

After checking the above items, you can click the Retry button to refresh the summary screen to see if Remote Access has been enabled.

2. What can I do if I forget my password?

If you forget your password, you will need to perform a hard reset of your camera. This process will change all your settings back to the factory defaults.

To reset your camera, please use an unfolded paperclip to press and hold the RESET button for at least 10 seconds while your camera is plugged in.

3. Why does the LED not light up?

The power supply might be faulty. Confirm that you are using the provided DC 5V power supply for this network camera. Verify that the power

supply is correctly connected. If the camera is functioning normally, the LED may have been disabled. See “Admin” on page 44 for information about how to enable the LED.

4. Why is the camera’s network connection unreliable?

There might be a problem with the network cable. To confirm that the cables are working, ping the address of a known device on the network. If the cabling is OK and your network is reachable, you should receive a reply similar to the following (...bytes = 32 time = 2 ms).

Another possible problem may be that the network device such as a hub or switch utilized by the Network Camera is not functioning properly. Please confirm the power for the devices are well connected and functioning properly.

5. Why does the Network Camera work locally but not remotely?

This might be caused by the firewall protection. Check the Internet firewall with your system administrator. The firewall may need to have some settings changed in order for the Network Camera to be accessible outside your local LAN. For more information, please refer to the section about installing your camera behind a router.

Make sure that the Network Camera isn’t conflicting with any Web server you may have running on your network.

The default router setting might be a possible reason. Check that the configuration of the router settings allow the Network Camera to be accessed outside your local LAN.

6. Why does a series of broad vertical white lines appear through out the image?

It could be that the image sensor has become overloaded when it has been exposed to bright light such as direct exposure to sunlight or halogen lights. Reposition the camera into a more shaded area immediately, as prolonged exposure to bright lights will damage the sensor.

7. The camera is producing noisy images. How can I solve the problem?

The video images might be noisy if the camera is used in a very low light environment.

8. The images are poor quality, how can I improve the image quality?

Make sure that your computer’s display properties are set to at least 6-bit color. Using 16 or 256 colors on your computer will produce dithering

artifacts in the image, making the image look as if it is of poor quality.

You may also need to check your image settings to make sure the brightness, contrast, and other settings are set properly. For more, refer to "Image Setup" on page 32.

9. Why are no images available through the Web browser?

ActiveX might be disabled. If you are viewing the images from Internet Explorer make sure ActiveX has been enabled in the Internet Options menu. You may also need to change the security settings on your browser to allow the ActiveX plug-in to be installed.

If you are using Internet Explorer with a version number lower than 6, then you will need to upgrade your Web browser software in order to view the streaming video transmitted by the Network Camera.

Technical Specifications

SYSTEM REQUIREMENTS

- Microsoft Windows® 8/7/Vista/XP, or Mac with OS X 10.6 or higher
- PC with 1.3 GHz or above and at least 128 MB RAM
- Internet Explorer 7, Firefox 12, Safari 6, or Chrome 20 or higher version with Java installed and enabled

NETWORKING PROTOCOL

- IPV4, ARP, TCP, UDP, ICMP
- DHCP Client
- NTP Client (D-Link)
- DNS Client
- DDNS Client (DynDNS and D-Link)
- SMTP Client
- FTP Client
- HTTP Server
- PPPoE
- UPnP Port Forwarding

BUILT-IN PROTOCOL

- HomePlug AV

RESET BUTTON

- Reset to factory default

VIDEO CODECS

- H.264
- MJPEG
- JPEG for still images

VIDEO FEATURES

- Adjustable image size and quality
- Time stamp and text overlay

- Configurable motion detection windows
- Flip and Mirror
- Pre-event snapshot

RESOLUTION

- 1280 x 720, 640 x 480, 320 x 240 at up to 30 fps

LENS

- Focal length: 3.3 mm, F2.0

SENSOR

- 1/4" 1 MP Progressive CMOS Sensor

IR LED

- 6 meter illumination distance

MINIMUM ILLUMINATION

- Color: 1 lux @ F2.0 (Day)
- B/W: 0 lux @ F2.0 (Night)

VIEWING ANGLE

- Horizontal: 68.88°
- Vertical: 37.85°
- Diagonal: 79.77°

DIGITAL ZOOM

- Up to 4x

3A CONTROL

- AGC (Auto Gain Control)
- AWB (Auto White Balance)
- AES (Auto Electronic Shutter)

POWER

- Input: 100-240 V AC, 50/60 Hz

DIMENSIONS (W X D X H)

- 113 x 114 x 139 mm

WEIGHT

- 262 grams (without stand)
- Stand: 60.8 grams

MAX POWER CONSUMPTION

- 8 W

OPERATION TEMPERATURE

- 0 °C to 40 °C (32 °F to 104 °F)

STORAGE TEMPERATURE

- -20 °C to 70 °C (-4 °F to 158 °F)

HUMIDITY

- 20-80% RH non-condensing

EMISSION (EMI), SAFETY & OTHER CERTIFICATIONS

- FCC Class B
- IC
- C-Tick
- CE