

AIRAVE 2.5

User Guide

©2012 Sprint. Sprint and the logo are trademarks of Sprint. Other marks are trademarks of their respective owners.



Important Messages

IMPORTANT: Sprint's policies often do not apply to third-party applications. Third-party applications may access your personal information or require Sprint to disclose your customer information to the third-party application provider. To find out how a third-party application will collect, access, use, or disclose your personal information, check the application provider's policies, which can usually be found on their website. If you aren't comfortable with the third-party application's policies, don't use the application.

Table of Contents

Introduction	1
Getting Started.....	2
Check What's in the Box	2
Set up at a glance	2
Setting up Your AIRAVE™	3
External GPS Antenna Setup	5
When is Your AIRAVE Ready for Use?	6
Setting up Optional Components	7
PC or LAN Router Setup	7
Configuring AIRAVE™ Router.....	8
Adding Your ISP User Name and Password	9
Using Your AIRAVE™.....	12
How AIRAVE Works.....	12
Your Broadband Connection Speed.....	12
How Calls and Data Go Over the Internet.....	13
Maintenance.....	13
Ventilation	13
Cleaning	13
Troubleshooting	14
Troubleshooting Installation Problems.....	14
Resetting the AIRAVE	15
LED Quick Reference.....	16
Using LEDs	17
FAQ.....	21
Why does the AIRAVE™ need a GPS antenna?.....	21
Why does the AIRAVE™ need an external GPS antenna?	21
What happens to the AIRAVE™ if there is a power outage or if you lose Internet access? 21	
Can you move the AIRAVE™ to another location?	21
How do I know if my phone is connecting through the AIRAVE?.....	21
Getting Help	21

Safety Information.....	23
General Precautions.....	23
FCC Information.....	24
! FCC Radiation Exposure Statement	24
FCC Part 15.....	24

Introduction

This User Guide introduces you to the SPRINT® AIRAVE™ service and all its features. It's divided into four sections:

- [Getting Started](#) page 2
- [Setting up Optional Components](#) page 7
- [Using Your AIRAVE™](#) page 12
- [Troubleshooting](#) page 14
- [Safety Information](#) page 23

Throughout this guide, you'll find tips and techniques that help you make the most of your new device and service. The Table of Contents and Index also help you quickly locate specific information. It is important that you read each section and note any special requirements. However, if you'd like to get right to a specific feature, simply locate that section in the Table of Contents and go directly to that page. Follow the instructions in that section, and you'll be ready to use your AIRAVE in no time.

WARNING: Please read the safety information on page 23 to learn about how to safely use your device. Failure to read and follow the safety information in this user guide may result in serious bodily injury, death, or property damage.

Getting Started

Check What's in the Box

Ensure that the following items are in the box:

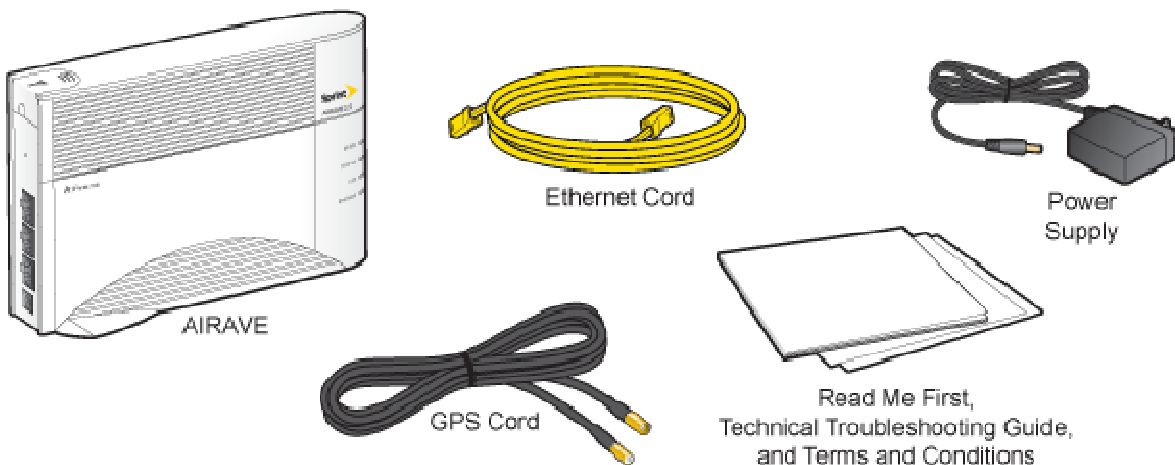

Tip: See the Read Me First for detailed illustrations on setting up your AIRAVE.

Set up at a glance

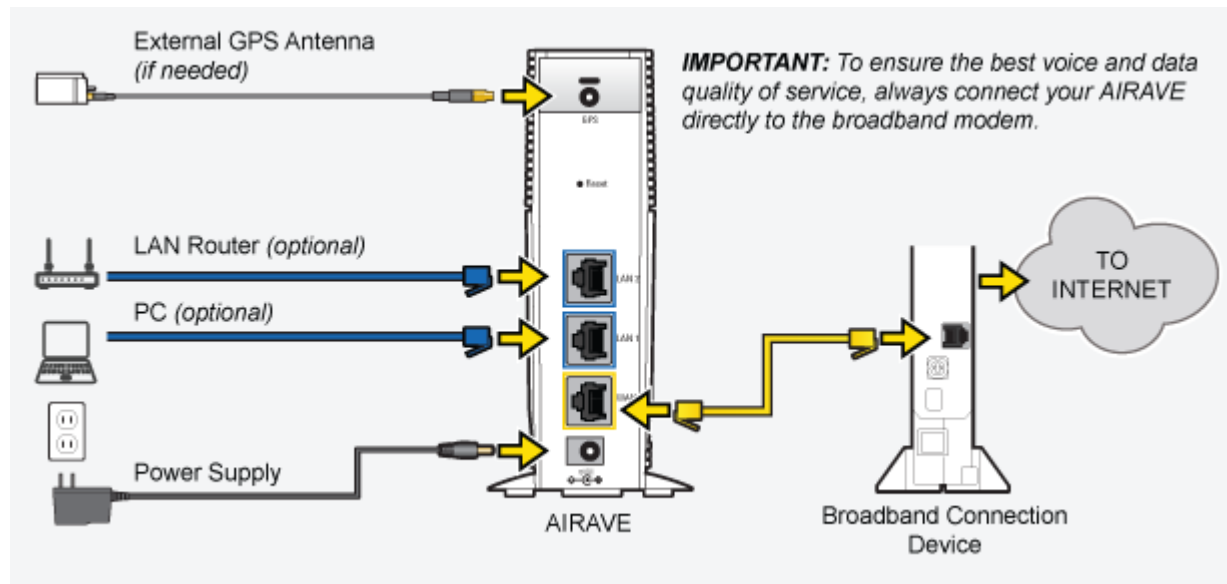

Setting up Your AIRAVE™



1. Disconnect the power from all devices on your network.

Note: This includes your cable or DSL modem and router.

2. Place your AIRAVE close to a window and in a central location. For best results, place the AIRAVE in an elevated location, such as the top of a bookshelf or tall cabinet.

Note: In large homes, the external GPS antenna can be used to allow the AIRAVE to be placed in a more central location. This allows the AIRAVE to provide even coverage throughout the home.

3. Connect one end of the yellow Ethernet cable to an available LAN port on your broadband modem.

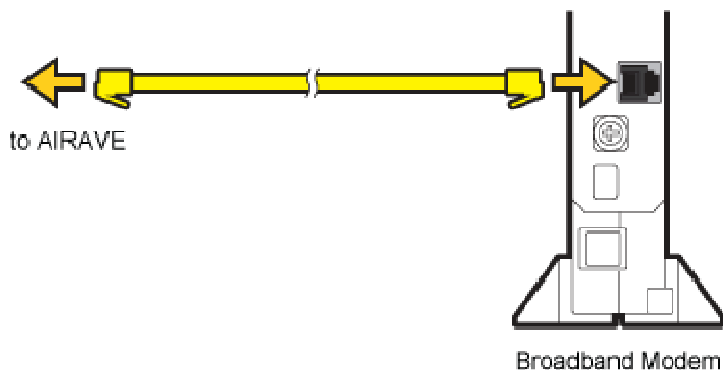

4. Connect the other end of the Ethernet cable to your AIRAVE's yellow WAN port.

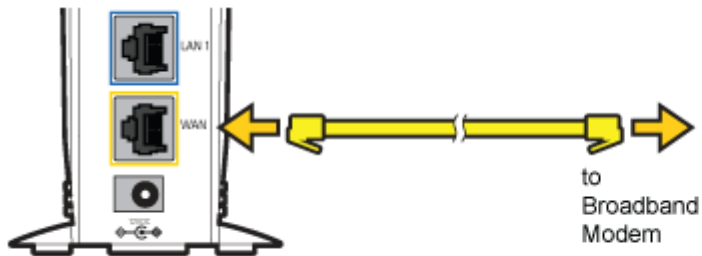

5. Turn on your cable or DSL modem.

Important Wait a couple of minutes for the cable or DSL modem to fully initialize before continuing.

6. Plug the power supply connector into the black power port on your AIRAVE.

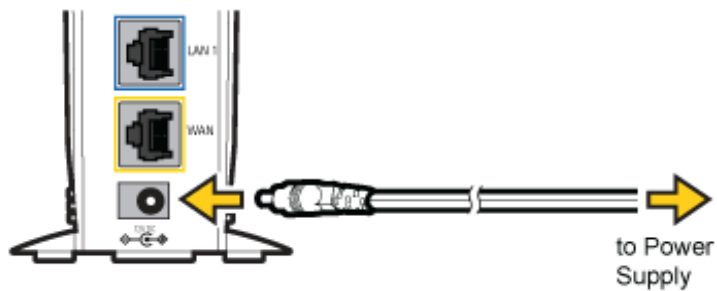

7. Plug the other end into an available electrical outlet.

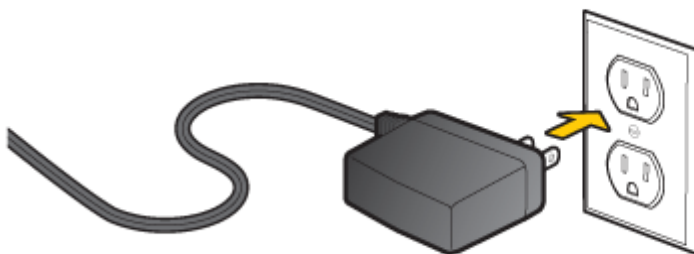

External GPS Antenna Setup

Use the external GPS antenna if your AIRAVE's internal antenna does not gain a signal for GPS lock (indicated by a solid red GPS LED for more than 40 minutes, solid green indicates GPS lock). Connect the external GPS antenna to your device's GPS connection port.

Note: After initial installation GPS may take 30-40 minutes to get a GPS fix.

1. Remove the GPS antenna module from the back of the AIRAVE. Connect the GPS cord to the antenna module and the AIRAVE. (See inset in drawing.)
2. Place the external GPS antenna horizontally on a flat surface as close to a window as possible. The antenna works best in an open area where it can easily pick up signals.

Note: Be sure to place the GPS antenna module tape-side down on a horizontal surface.

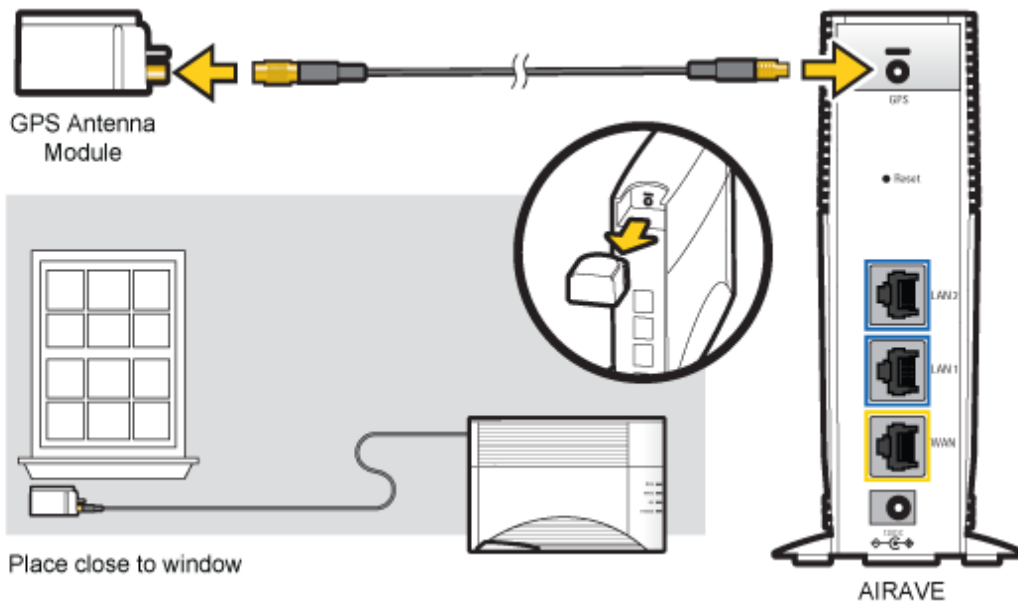

When is Your AIRAVE Ready for Use?

After installing and turning on your AIRAVE for the first time, AIRAVE goes through an automated setup sequence. See the table below.

During this time, the device's green LEDs will be solid for a few seconds, and then all LEDs, except the Broadband LED, will turn off until the software loads. This process may take up to 2 hours.

When the Broadband, GPS, Network, and Mobile LEDs are solid green, your AIRAVE is ready for use.

Note: For a summary of LED status indicators, see [LED Quick Reference](#). For complete descriptions of LED states, see [Using LEDs](#).

Tip: You will hear three short beeps when placing or answering calls on your wireless phone if you are within range of the AIRAVE.

The following table shows the LED startup sequence.

Broadband	GPS	Network	Mobile	AIRAVE State
Solid Green	Solid Green	Solid Green	Solid Green	Initial hardware test (5-10 seconds)
Solid Green	Off	Off	Off	Software loading (25 seconds or less)
Solid Green	Blinking Red	Blinking Red	Blinking Red	Software loaded and Services Started
Solid Green	Blinking Red	Blinking Red	Blinking Red	WAN port connected over local network
Solid Green	Blinking Red	Blinking Red	Blinking Red	WAN port connected IPsec tunnel up
Solid Green	Solid Green	Solid Green	Blinking Red	WAN port connected GPS time fix available IPsec tunnel up
Solid Green	Solid Green	Solid Green	Solid Green	WAN port connected GPS time fix available IPsec tunnel up OneX service up

Setting up Optional Components

PC or LAN Router Setup

Connect any devices that you have, such as a PC or a LAN router, to the AIRAVE's blue LAN ports.

Tip: To ensure the best voice and data quality of service, always connect the LAN router to your AIRAVE. Do not connect it to the broadband connection device.

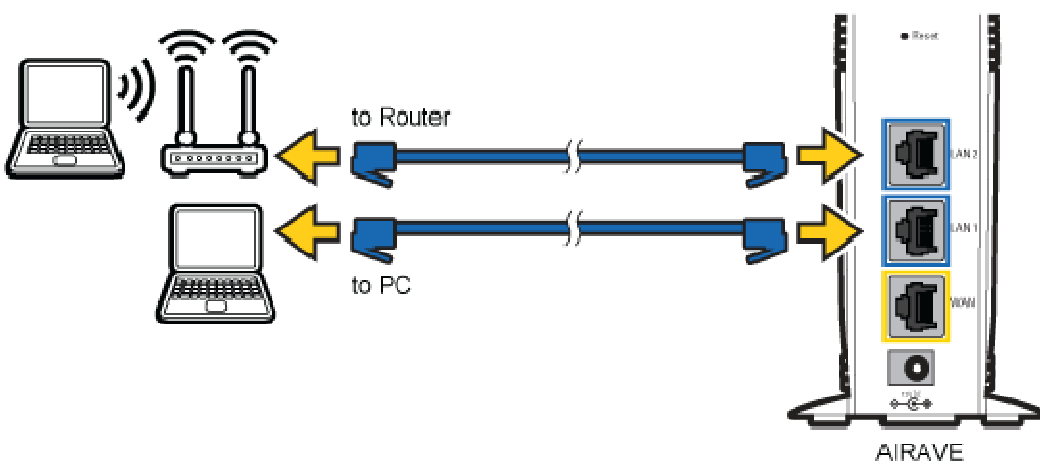

Configuring AIRAVE™ Router

Your AIRAVE contains a built-in router. Usually, you can plug your AIRAVE into your broadband connection device, such as a cable modem, DSL modem or FiOS (a high-speed, fiber optic broadband Internet service), without performing any additional steps. However, you may need to configure the built-in router to work with your ISP modem or connection device.

The following table lists typical ISP setups and actions to take so that the built-in router works with your existing ISP setup.

Broadband connection device	LED display pattern	Symptom	Action to take
Cable modem	Broadband and Mobile solid green	Not applicable (working properly)	Not applicable
DSL modem	Broadband LED blinking red	Cannot access Internet	Go to “Adding Your ISP User name and Password”
DSL modem with built-in router	Broadband LED blinking red	Cannot access Internet	See FAQ . If the problem persists, contact Customer Support as described in “Getting Help”
Cable modem with built-in router	Mobile LED blinking red	Cannot make a mobile phone call through the AIRAVE	
FiOS			

Adding Your ISP User Name and Password

If you are using a DSL modem and your device cannot connect to the Internet, you may need to enter your Internet service provider (ISP) account user name and password so that the AIRAVE can connect to the Internet.

Tip: Before you begin, obtain your ISP user name and password. Contact your ISP if you do not have this information.

1. Ensure that your PC is networked with the AIRAVE.
2. Enter the following IP address in your Web browser:

192.168.17.1:80

The login dialog box appears.

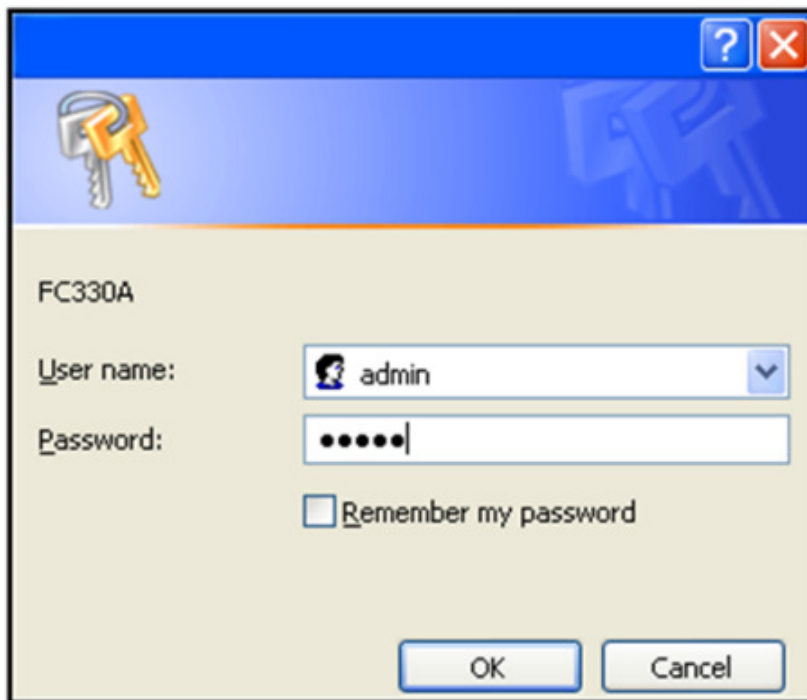

3. Enter "admin" in both the User name and Password boxes and click OK.

4. Click the **Setup** tab on the Router status page menu bar. Click **WAN Settings**.

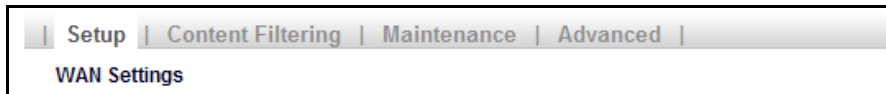

5. Ensure that **Yes (PPPoE)** is selected.



A rectangular form with a light gray background and a dark border. It contains the following elements: the text 'Does Your Internet Connection Require a Login?' followed by two radio buttons. The first radio button is selected and is labeled 'Yes (PPPoE)'. The second radio button is unselected and is labeled 'No (DHCP)'. Below the radio buttons is the text 'Encapsulation' followed by a dropdown menu showing 'PPPoE (PPP over Ethernet)' with a downward arrow.

6. Enter your ISP user name in the Login box (overwrite "Guest") and your password in the Password box. Click **OK**.



A rectangular form with a light gray background and a dark border. It contains two labels on the left: 'Login' and 'Password'. To the right of the 'Login' label is a text input field containing the text 'Guest'. To the right of the 'Password' label is an empty text input field.

7. Accept the defaults in other fields on the screen and click **Apply**.

The screenshot shows a network configuration window with the following sections and fields:

- Account Name (If Required)**: A text input field.
- Domain Name (If Required)**: A text input field.
- Internet IP Address**:
 - Get Dynamically From ISP
 - Use Static IP Address
 - IP Address**: Four separate input boxes for the IP address octets, separated by dots.
- Domain Name Server (DNS) Address**:
 - Get Automatically From ISP
 - Use These DNS Servers
 - Primary DNS**: Four input boxes containing the values 10, 1, 0, and 5, separated by dots.
 - Secondary DNS**: Four input boxes containing the values 10, 4, 0, and 5, separated by dots.
- Router MAC Address**:
 - Use Default Address
 - Use Computer MAC Address
 - Use This MAC Address
 - A text input field containing the MAC address 00:05:B9:00:6C:8C.

At the bottom of the window are two buttons: **Apply** and **Cancel**.

When the Broadband LED is solid green your Internet connection is available. If setting up PPPoE takes more than 15 minutes at startup, the Broadband LED will turn solid red. Once the PPPoE connection is set up, the LED turns solid green. If the LED remains solid red, contact your ISP.

Using Your AIRAVE™

How AIRAVE Works

The AIRAVE™ is a *femtocell*, a personal base station with a radio unit that is similar to a cell tower radio. The base station uses a low-power antenna to transmit voice and data cellular signals in your home or small office.

Base stations give you better cellular coverage, which means a stronger signal and improved voice quality. A strong signal can extend battery life. Also, data applications on smartphones, such as mobile email devices, work faster.

The AIRAVE connects to Sprint's network through your broadband Internet connection. Outgoing calls go from the AIRAVE over a secure connection to Sprint's network; incoming calls reverse this route.

Your Broadband Connection Speed

The AIRAVE's actual transmission speed is only as fast as your maximum broadband connection speed. Internet congestion, the number of users on your provider's network, and other factors can decrease your actual broadband connection speed. Individual bandwidth needs vary per customer. Sprint recommends a minimum of 300 kbps (both upstream and downstream) for voice services and 3 Mbps downstream and 1.8 Mbps upstream for data services.

The following table shows recommended bandwidth by usage type:

Usage Type	Recommended Download Speed	Recommended Upload Speed
Wireless Call	40 kbps per call	40 kbps per call
Wireless Data	Up to 3 Mbps per session	Up to 1.8 Mbps per session

How Calls and Data Go Over the Internet

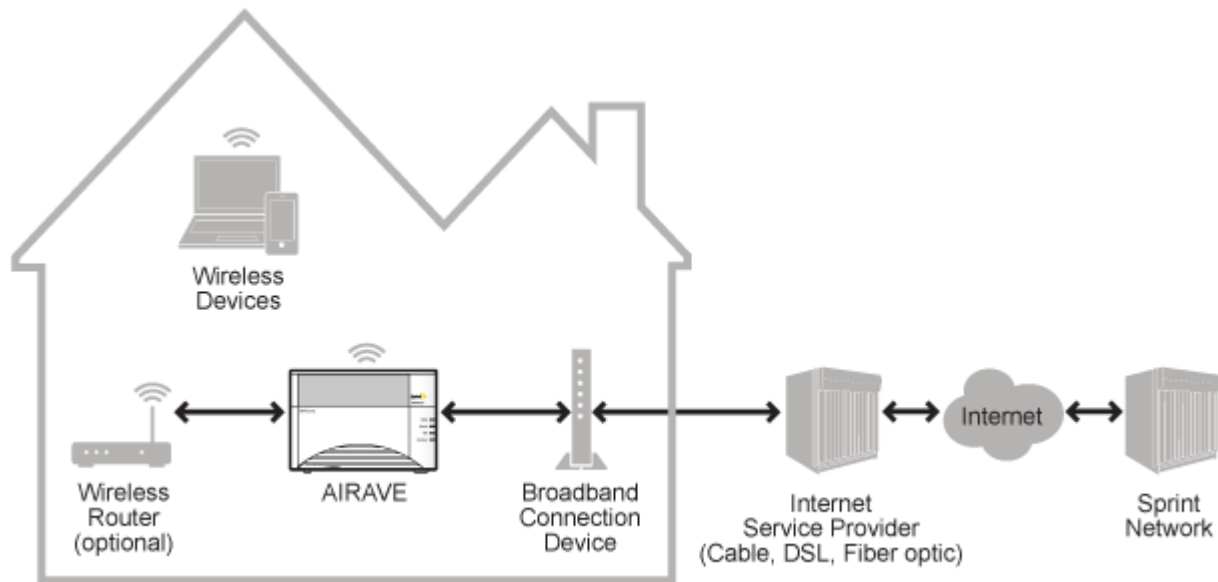

Maintenance

With normal use, your AIRAVE is maintenance-free. Follow the recommendations below to ensure that it runs optimally.

Ventilation

Your AIRAVE has ventilation slots that work best if you don't block the flow of air to them. Keep your device at least 2 inches (5 cm) from walls and other surfaces to ensure proper air flow.

Cleaning

Dust your AIRAVE occasionally to keep air vents clear of debris. Do not use liquid cleaners.

Troubleshooting

Troubleshooting Installation Problems

If your Broadband turns solid red after 15 minutes, reversing the order of turning on the AIRAVE and your cable or DSL modem can often resolve this problem. To reverse the order, follow these procedures:

1. Unplug all cables and power cords from all devices. You can unplug devices in any order.
2. Connect all Ethernet and GPS cables as described in “Setting up Your AIRAVE™” (page 4).

Important: Do not connect any power cords at this point in the procedure.

3. Plug the AIRAVE into an electrical outlet.
4. Wait 4 minutes.
5. Plug your cable or DSL modem into an electrical outlet.

Tip: You may want to consult your cable or DSL modem documentation for any special procedures for connecting a device directly to your cable or DSL modem.

If the Broadband LED turns solid red after 15 minutes, call Customer Support as described in [Getting Help](#).

Resetting the AIRAVE

If your AIRAVE was operating properly for an extended period and the Mobile LED suddenly starts blinking red, the AIRAVE may have a problem requiring a reset. To reset the AIRAVE, push the Reset button for at least 10 seconds (as shown in the drawing below).

After resetting, your AIRAVE goes through an automated setup sequence. During this time, the device's green LEDs will be solid for a few seconds, and then all LEDs will turn off until the software loads. The reset process may take 30-45 minutes.

After resetting the AIRAVE, if the failure persists, contact Customer Care. See Getting Help on page 21.

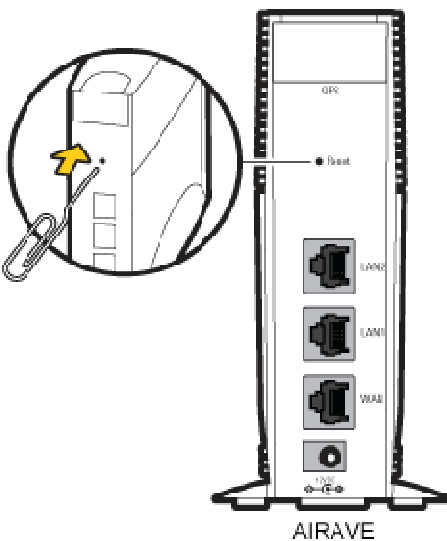

LED Quick Reference

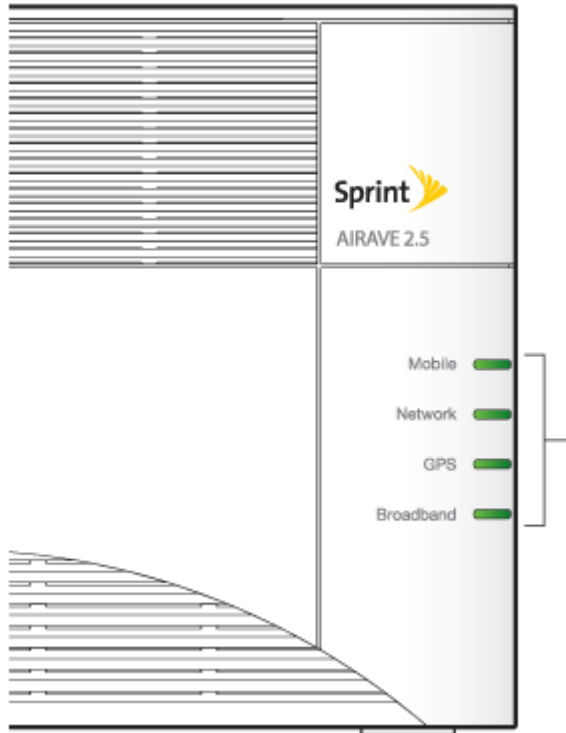

Mobile

- Solid green: Ready
- Solid red: Hardware problem
- Blinking red: Service error
- Off: No service, service disabled, no power, or LED malfunction

Network

- Solid green: Ready
- Solid red: AIRAVE is not connected router/modem for more than 15 minutes
- Blinking red to solid red: Service error
- Off: No power or LED malfunction

GPS

- Solid green: Ready
- Blinking red: Acquiring a lock
- Solid red: GPS lock not available
- Off: No power or LED malfunction

Broadband

- Solid green: Connected to the Internet
- Solid red: AIRAVE is not connected to router/modem for more than 15 minutes
- Blinking red: Service error
- Off: No power or LED malfunction

Note: For complete descriptions of LED states, see [Using LEDs](#).

Using LEDs

Use the LEDs to troubleshoot your device.

LED	Display pattern	Action to take
Mobile	Solid green	Service is up.
	Solid red	Hardware problem. Call Customer Support as described in Getting Help.
	Blinking red	Service has not come up since startup or has gone down. If service has gone down, try resetting the AIRAVE as described in Resetting the AIRAVE. If this problem persists, call Customer Support as described in Getting Help.
	Off	If the LED turns off after turning on from either a blinking red or solid green state, AIRAVE is not activated. Call Customer Support as described in Getting Help.
Network	Solid green	None. Ready.
	Blinking red to solid red	Service has not come up since startup or has gone down. If this problem persists, call Customer Support as described in Getting Help.
	Blinking red	Network connection has gone down or has not come up since startup, for 15 minutes or less.
	Solid red	If all LEDs are solid red there is a hardware problem. Call Customer Support as described in Getting Help.

	Off	LED malfunction. Call Customer Support as described in Getting Help.
GPS	Solid green	None. GPS is ready.
	Blinking red	<p>GPS is trying to acquire a lock. Perform the following steps. If GPS fix was not achieved after GPS restart (either at power-up or after recovery from an error), then the GPS LED turns solid red after more than 30 minutes.</p> <p>If you have not already done so, connect the external GPS antenna to your device.</p> <p>If the external GPS antenna is already connected, move it to a different location, as close to a window as possible.</p> <p>If this problem persists, call Customer Support as described in Getting Help.</p>
	Solid red	<p>GPS fix is not available for more than 30 minutes.</p> <p>If you have not already done so, connect the external GPS antenna to your device.</p> <p>If the external GPS antenna is already connected, move it to a different location, as close to a window as possible.</p> <p>If this problem persists, call Customer Support as described in Getting Help.</p> <p>If all LEDs are solid red there is a hardware problem. If this problem persists, call Customer Support as described in Getting Help.</p>
Broadband	Solid green	None. Connected to the Internet.

	Solid red	<p>AIRAVE is not connected to the router/modem for more than 15 minutes.</p> <p>If all LEDs are solid red there is a hardware problem.</p> <p>Call Customer Support as described in Getting Help.</p>
	Blinking red	<p>Service error.</p> <p>Check if your broadband modem or broadband router has a problem. Reset your broadband connection device. If the problem with the broadband device persists, contact your Internet service provider (ISP).</p> <p>Ensure that the AIRAVE's router is correctly configured to access the Internet service. See "Configuring AIRAVE™ Router" (page 9).</p> <p>Restart the device by turning the power off and on.</p> <p>If this problem persists, call Customer Support as described in Getting Help.</p>
	Off	<p>The LED is not working or the unit has no power. If this problem persists, call Customer Support as described in Getting Help.</p>
All	Solid red	<p>The AIRAVE cannot pass a hardware self-test. Call Customer Support as described in Getting Help.</p>

FAQ

Why does the AIRAVE™ need a GPS antenna?

The AIRAVE has a GPS antenna so that it can:

- Synchronize properly with the rest of Sprint's network.
- Determine and select the correct radio frequencies available in your area so that the AIRAVE uses the correct ones.

Why does the AIRAVE™ need an external GPS antenna?

Your device needs the external antenna only when the internal GPS antenna cannot lock on to sufficient satellite signals. The external antenna lets the AIRAVE lock on to the greatest number of satellites.

What happens to the AIRAVE™ if there is a power outage or if you lose Internet access?

The AIRAVE needs both a broadband Internet connection and a constant power supply to work. During a power outage your wireless phone or device will immediately switch to the Sprint network.

Can you move the AIRAVE™ to another location?

Yes, you can move your device to another location within the Sprint network. However, to move your device to a different address, you must first update your service address by logging into your account on www.sprint.com.

How do I know if my phone is connecting through the AIRAVE?

By dialing *99 on your wireless phone, an audio message will confirm if you are in range of the AIRAVE. Also, you will hear three short beeps on your wireless phone before making and receiving calls.

Getting Help

If you need help with your AIRAVE, contact Sprint Customer Care.

- Online (sprint.com/airaveaccesspoint)
- For activation and technical issues dedicated AIRAVE Help Desk(1-866-556-7310)
- For billing and other questions (1-888-211-4727)

Safety Information

General Precautions

- Dust the AIRAVE occasionally to keep air vents clear of debris. Do not wash it.
- The AIRAVE has ventilation slots that work best if you don't block them. Keep the AIRAVE at least 2 inches (5 cm) from walls and other surfaces to ensure proper air flow.
- Do not operate the AIRAVE in an extremely dusty or humid environment.
- Avoid placing the AIRAVE near radiators or other heating sources.
- Avoid locating the AIRAVE where it could be exposed to direct sunlight for prolonged periods.
- Do not connect the AIRAVE to a power strip containing an excessive number of other devices.
- Although your AIRAVE is quite sturdy, it is a complex piece of equipment and can be broken. Avoid dropping, hitting, bending, or sitting on it.
- Do not immerse the AIRAVE in water or get it wet. If your device does get wet, unplug it immediately until it dries.
- Do not allow children to play with the AIRAVE. They could hurt themselves and others or damage the device.

Note: For the best care of your AIRAVE, only Sprint-authorized personnel should service your device and accessories. Failure to do so may be dangerous and void your warranty.

FCC Information

! FCC Radiation Exposure Statement

Important: Changes or modifications not expressly approved by Airvana LLC could void your authority to operate the equipment.

This device complies with FCC's RF radiation exposure limits set forth for an uncontrolled environment under the following conditions:

- This device should be installed and operated such that a minimum separation distance of 8 inches (20 cm) is maintained between the radiator (antenna) and the user's or nearby person's body at all times.
- This transmitter must not be co-located or operating in conjunction with any other antenna or transmitter.

For more information, see the publication *Femtocells and Health* at [http:// www.femtoforum.org](http://www.femtoforum.org) or visit the FCC website at www.fcc.gov.

FCC Part 15

This device has been tested and found to comply with the limits for a Class B digital device, pursuant to Part 15 of the FCC Rules. These limits are designed to provide reasonable protection against harmful interference in a residential installation. This device generates, uses, and can radiate radio frequency energy and, if not installed and used in accordance with the instructions, may cause harmful interference to radio communications. However, there is no guarantee that interference will not occur in a particular installation. If this device does cause harmful interference to radio or television reception, which can be determined by turning the device off and on, the user is encouraged to try to correct the interference by one of the following measures:

- Re-orient or relocate the receiving antennas of other devices.
- Increase the separation between the AIRAVE and other device receivers.
- Connect the AIRAVE into an outlet on a circuit different from that to which the other device receiver is connected.
- Consult the dealer or an experienced radio/TV technician for help.

Index

AIRAVE

- External GPS Antenna, 5
- External GPS Antenna; Antenna, GPS, 20
- FAQ, 20
- Help, 20
- Internet, 13
- Location, 20
- Placement, 21
- Safety Information, 22

Broadband

- Connection Speed, 12

Modems;Cable Modem;DSL Modem;FiOS

- Connection Device, 8

DSL Modem, 9

FCC Information, 22

Internet Service Provider (ISP)

User Name

- Password;Password;User Name

- Internet Service Provider (ISP), 9

Ethernet Cable

Port

- Connection Device;Modems, 3

LAN

Port

- LAN, 7

LAN

- Router, 7

LEDs

- Troubleshooting, 17, 18

LEDs

- Broadband, 11, 14

- Mobile, 6

- Quick Reference, 16

Port

LAN

- Port, 3

Power Outage, 20

Text Messaging

- Sending a Text Message, 3

Troubleshooting

- Installation Problems, 14

LEDs, 18