



OneCell
Installation and Commissioning

Release 1.0

DRAFT

Document Number: 913020
Document Revision: 10.05
Date: April 2015



Copyright © 2015 Airvana LP. All rights reserved.

Airvana is a registered trademark of Airvana LP (“Airvana”). All other trademarks are trademarks of their respective owners.

This document contains information that is the property of Airvana . This document may not be copied, reproduced, reduced to any electronic medium or machine readable form, or otherwise duplicated, and the information herein may not be used, disseminated or otherwise disclosed, except with the prior written consent of Airvana.

THE SPECIFICATIONS AND INFORMATION REGARDING THE PRODUCTS IN THIS MANUAL ARE SUBJECT TO CHANGE WITHOUT NOTICE. ALL STATEMENTS, INFORMATION, AND RECOMMENDATIONS IN THIS MANUAL ARE BELIEVED TO BE ACCURATE BUT ARE PRESENTED WITHOUT WARRANTY OF ANY KIND, EXPRESS OR IMPLIED. USERS MUST TAKE FULL RESPONSIBILITY FOR THEIR APPLICATION OF ANY PRODUCTS.

THE SOFTWARE LICENSE AND LIMITED WARRANTY FOR THE ACCOMPANYING PRODUCT ARE SET FORTH IN THE INFORMATION PACKET THAT SHIPPED WITH THE PRODUCT AND ARE INCORPORATED HEREIN BY REFERENCE. IF YOU ARE UNABLE TO LOCATE THE SOFTWARE LICENSE OR LIMITED WARRANTY, CONTACT YOUR AIRVANA SALES REPRESENTATIVE FOR A COPY.

DRAFT

Contents

New in this release

About this document

Audience	v
Purpose.....	v
What you need to know	v
Terminology.....	v
Customer documentation	vi
Conventions	vii
Notes, cautions, and warnings	viii

PART 1 OVERVIEW AND PREPARATION

Chapter 1 Airvana OneCell overview

Overview.....	1-2
Airvana OneCell system	1-2
OneCell hardware components	1-3
Controller ports.....	1-4
Controller LEDs	1-5

Chapter 2 Preparing to install the OneCell system

Installation overview.....	2-2
GPS antenna installation requirements	2-2
GPS antenna installation considerations	2-2
Sample GPS setup	2-2
Ethernet switch installation requirements.....	2-3

PART 2 ONECELL COMPONENT INSTALLATION

Chapter 3 Baseband Controller installation

Preparing for Baseband Controller installation.....	3-2
Installing the Controller Module into a rack.....	3-2

Chapter 4
Radio Point Installation

Radio Point installation overview4-2
Ceiling mount.....4-2
 Mounting the Radio Point on the ceiling tile4-4
 Mounting the Radio Point above the ceiling tile.....4-9
Flown mount4-15
 Flown mount installation.....4-16
Pole mount4-17
 Pole mount installation.....4-19

PART 3 **APPENDICES**

Appendix A
Safety

FCC Radiation Exposure StatementA-2
 FCC Part 15A-2
Human exposure limits for OneCell deployments.....A-2
 Reference documentsA-3

Appendix B
Specifications

Electrical ratings and technical dataB-2
SPF/SPF+ specifications.....B-2

Appendix C
Installation troubleshooting

Controller LED patterns.....C-2
Radio Point LED patternsC-4

DRAFT

DRAFT

List of figures

Figure 1-1	OneCell Deployment	1-3
Figure 1-2	Controller ports	1-4
Figure 2-1	GPS antenna setup	2-3
Figure 4-1	Airvana ceiling mount kit contents.....	4-2
Figure 4-2	On-ceiling mounting hardware, system integrator provided	4-3
Figure 4-3	Above ceiling mount hardware, system integrator provided.....	4-3
Figure 4-4	Mounting bracket kit contents	4-16
Figure 4-5	Mounting bracket kit contents	4-18

DRAFT

List of tables

Table 1	Customer documentation	vi
Table 2	Conventions	vii
Table A-1	RF exposure for OneCell at maximum power internal antennas	A-3

DRAFT

DRAFT

New in this release

The following section lists documentation changes in *OneCell Hardware Installation and Configuration* (913025) for R1.0.

Revision 10.05

- Added new chapter, [Chapter 4, Radio Point Installation](#)

Revision 10.04

- [Chapter 3, Baseband Controller installation](#)
 - Added caution to [Installing the Controller Module into a rack](#) on page 3-2
 - Added caution and drawing to [step 6 on page 3-4](#)
- [Appendix B, Specifications](#)
 - Added topic, [Electrical ratings and technical data](#) on page B-2

Revision 10.03

- Added content to [Chapter 4, Radio Point Installation](#)

Revision 10.02

- Added new chapter, [Chapter 4, Radio Point Installation](#)

Revision 10.01

- Initial document release

DRAFT

DRAFT

About this document

This document provides the procedures for installing and configuring the Controller Unit and Radio Points.

Audience

This document is written for computer hardware installers and administrators, network architects and business planners who are responsible for the planning and design of the Airvana OneCell deployment environment.

Purpose

This guide provides the information necessary for installing the OneCell hardware in the operator's network.

What you need to know

The reader should have a basic understanding of:

- Data networks
- LTE technology
- General telecommunications practices

Terminology

This guide uses the following hardware-specific terminology.

DRAFT

Name	Definition
Hot-swappable	Hot-swappable components can be installed or removed while the system is running, without using any software commands.
Hot-pluggable	Using the proper software commands, you can install or remove hot-pluggable components while the system is running.
FRU	Field-replaceable units must be removed and installed only by authorized Oracle service personnel.
CRU	Customer-replaceable units can be removed and replaced by any qualified service provider.

Customer documentation

The following table lists available documents in the OneCell documentation suite.

Table 1. Customer documentation

Title	Contents
<i>OneCell CLI Reference</i> (913020)	Describes the Switched IQ CLI commands including parameters, syntax, and sample output.
<i>OneCell System Troubleshooting</i> (913022)	Cover common troubleshooting scenarios in deployed devices and troubleshooting methods.
<i>OneCell Network Planning Guide</i> (913023)	Describes main components of the Switched IQ system, high-level view of HW components, how do you engineer an in-building system, how do you determine RU locations, how to design in-building systems and how to determine Radio Point locations. Contains best practices for deployment, including when to use clustering, and how to manage capacity.
<i>OneCell Hardware Installation and Configuration</i> (913025)	Includes detailed installation instructions for Controller Unit and Radio Points hardware, planning the installation, physical install, how to configure the installation, commissioning the installation to service; verification tests after the installation.
<i>OneCell Administration</i> (913026)	Contains enterprise-level monitoring and alarms.

DRAFT

Table 1. Customer documentation (continued)

Title	Contents
<i>OneCell On-site Troubleshooting</i> (913027)	Describes symptoms and troubleshooting methods at the enterprise level, including basic on location troubleshooting up to the core, and when to call next level of support.
<i>OneCell Deployment Guide</i> (913028)	Contains the device network overview, including Airvana provided components and required components from other vendors, DMS overview, and device overview and requirements.

Conventions

This guide uses the following text conventions, as applicable.

Table 2. Conventions

Convention	Description
Syntax symbols	
<>	Enclose a required parameter or set of parameters. For example: <code>>band-class <class></code> <code><class></code> is a required parameter.
[]	Enclose an optional parameter or set of parameters. For example: <code>>activate image <version> [reboot]</code> <code>[reboot]</code> is an optional parameter.
	Separates items on a list of parameters, only one of which can be used. For example: <code>>channel-included <yes no></code> A valid command is: <code>>channel-included yes</code>

DRAFT

Table 2. Conventions (*continued*)

Convention	Description
Font usage	
Bold input font	Indicates text that must be entered exactly as shown. For example: Enter <code>ping 192.23.10.12</code> .
<i>Italic input font</i>	Indicates a variable parameter for which you must provide an actual value. For example: <code>>authentication key <aukey></code> <code><aukey></code> is a variable parameter. A valid command is: <code>>authentication key 9782503000</code>
Plain output font	Indicates system output in a command line or system-generated file. For example: IP address 192.23.10.12 is alive.
<i>Italic output font</i>	Indicates a variable in system output in a command line or system-generated file. For example: Installation of release <code><release></code> is complete.
<i>Plain italic font</i>	Indicates file names, directory paths, book titles, chapter titles, and user accounts.
Bold font	Indicates text that appears on screen exactly as shown, for example, names of screens, names of buttons, items on menus, and items on pull down lists.
blue text	Indicates a hypertext link.
Other conventions	
>	Indicates graphical user interface (GUI) menu path. For example: Select Edit > Add Network to open the Add Network screen.

Notes, cautions, and warnings



NOTE

Notes provide additional information about the subject text.



CAUTION

Cautions indicate that procedures, if performed incorrectly, can cause equipment damage or data loss.



WARNING

Warnings indicate that procedures, if performed incorrectly, can harm you.

DRAFT

DRAFT

Part I: Overview and preparation

Chapter 1 **Airvana OneCell overview**

Chapter 2 **Preparing to install the OneCell system**

DRAFT

DRAFT

Airvana OneCell overview

This chapter contains a high level overview of the OneCell deployment and the OneCell components installed in the OneCell system.

Overview	1-2
Airvana OneCell system	1-2
OneCell hardware components	1-3

DRAFT

Overview

OneCell is a revolutionary wireless system that can deliver the ultimate in wireless performance.

- It eliminates cell borders and handovers
- It can cover a large area with consistent user experience without any significant interference
- It can take advantage of multiple distributed radio points to deliver a stronger signal on both the downlink and the uplink
- It can deliver greater capacity through distributed (multi-user and single-user) MIMO and Coordinated Multipoint (CoMP)
- It has the flexibility to neutralize macro interference in co-channel small cell deployments
- It can be used to deliver unprecedented levels of capacity to hot spot areas by deploying radio points with overlapping coverage and enabling multi- user MIMO

In addition to these important benefits in user experience and data capacity, OneCell provides superior economics and investment protection, ease of deployment, support for multi-operator deployments.

Airvana OneCell system

OneCell is an in-building, enterprise solution for LTE that provides an in-building consistent signal. It operates as a wireless network with a single cell, called a controller, over distributed radio points. Network operators benefit from the OneCell because they reduce the load on their infrastructure.

DRAFT

Figure 1-1. OneCell Deployment

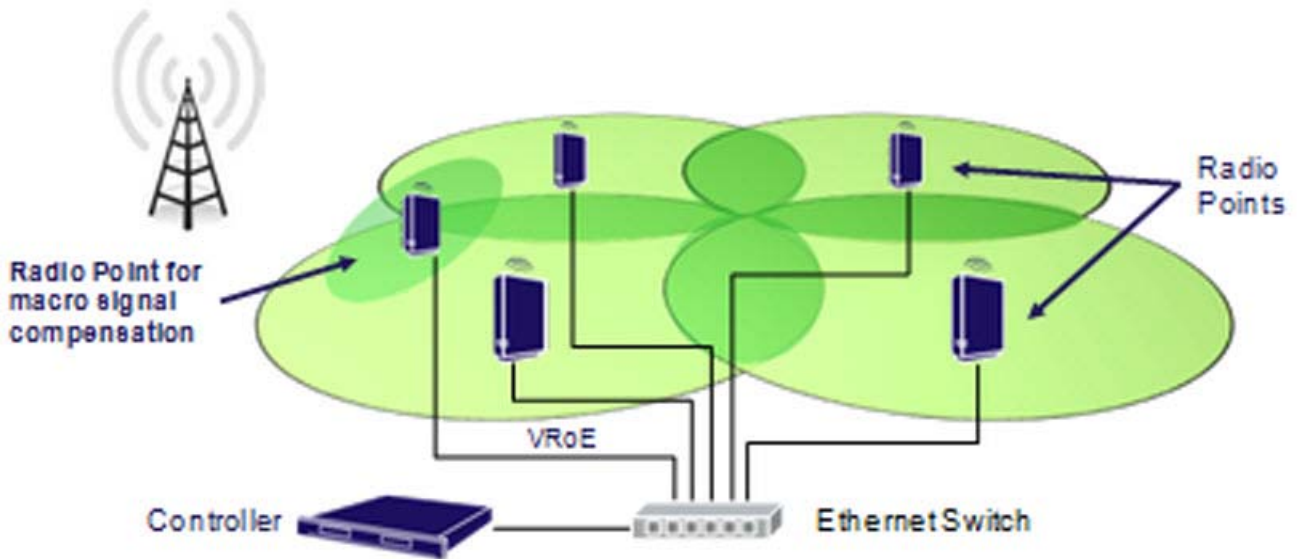

OneCell hardware components

The OneCell hardware consists of the following components:

- Baseband Controller
 - Chassis
 - Controller Unit (CU)
 - Power Fan Unit (PFU)
- Radio Points (RP)

DRAFT

Controller ports

The following ports are on the front panel of the Controller Unit.

- 12 Ethernet - ports 0-10 and MGMT; 7-10 are dual media ports
- 6 fiber optic - Ports 7-12

In addition, there is a connector used for the GPS antenna cable.

Port Number	Description
Ethernet	
MGMT	VLAN #80 – used for remote management of the OneCell system through a CLI
1-4	VLAN #10 – IQ data connection between the Controller and Radio Point through an Ethernet switch
5	VLAN #30 – used for IPsec through a WAN connected to an Ethernet switch
6-7	VLAN #1 – used for timing and SOAP/XML control data connected to an Ethernet switch
8-10	Future use
Fiber Optic	
7-12	Future use

Figure 1-2. Controller ports

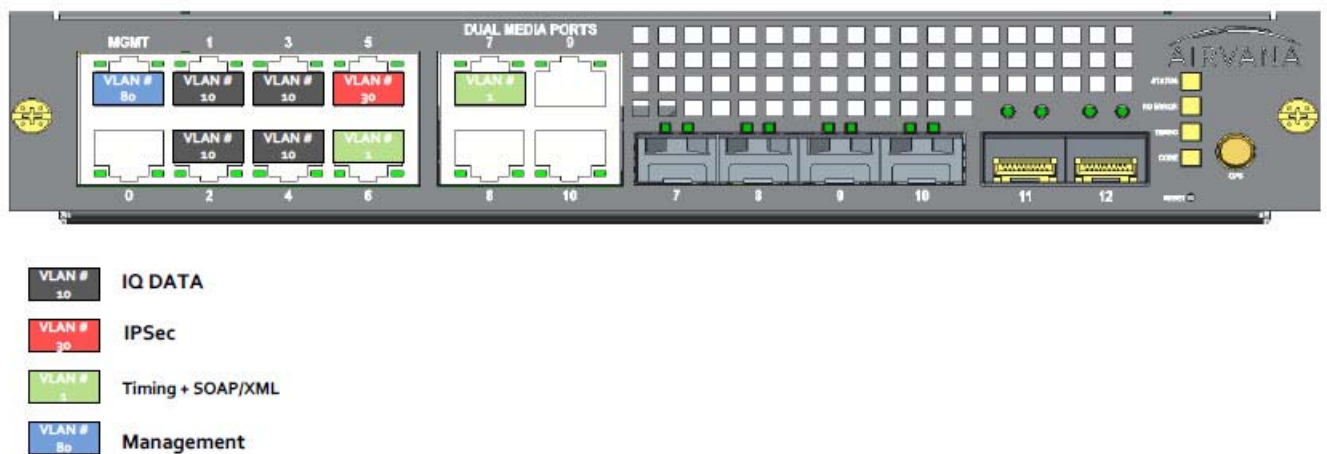

Controller LEDs

The Controller Module has four LEDs on the front panel.

- STATUS
- RU ERR
- TIMING
- CORE

When all of the LEDs are solid green, the power is on.

For more information on LED patterns, see [Controller LED patterns](#) on page C-2.

DRAFT

DRAFT

Preparing to install the OneCell system

Overview	2-2

DRAFT

Overview

This document describes the OneCell installation and includes:

- [Chapter 3, Baseband Controller installation](#)
- [Chapter 4, Radio Point Installation](#)

Before installing the OneCell components

Before installing the OneCell components, the system integrator must plan the network for the topology that will be deployed. See

DRAFT

Part II: OneCell component installation

Chapter 3 Baseband Controller installation

Chapter 4 Radio Point Installation

DRAFT

DRAFT

Baseband Controller installation

This chapter contains the Baseband Controller installation procedures, including chassis installation into a rack, Controller Unit and Power Fan Unit installation into the chassis and the cables required for a basic installation.

Preparing for Baseband Controller installation	3-2
Installing the Controller Module into a rack	3-2

DRAFT

Preparing for Baseband Controller installation

Open the shipping box. It should have the components for one complete Controller Unit:

- Chassis – including four mounting screws
- Controller Unit (CU)
- Power Fan Unit (PFU)

The Baseband Controller is 1U high. Be sure there is enough room for the Controller Unit in the rack.

Installing the Controller Module into a rack



CAUTION

The controller, when mounted, must in the horizontal position. No other orientations are allowed.



NOTE

The chassis requires four screws to secure it into the rack.

- 1 Slide the chassis into the rack.
- 2 Line up the holes in the chassis ears to the holes in the rack.

DRAFT

- 3 Secure the chassis with the screws.

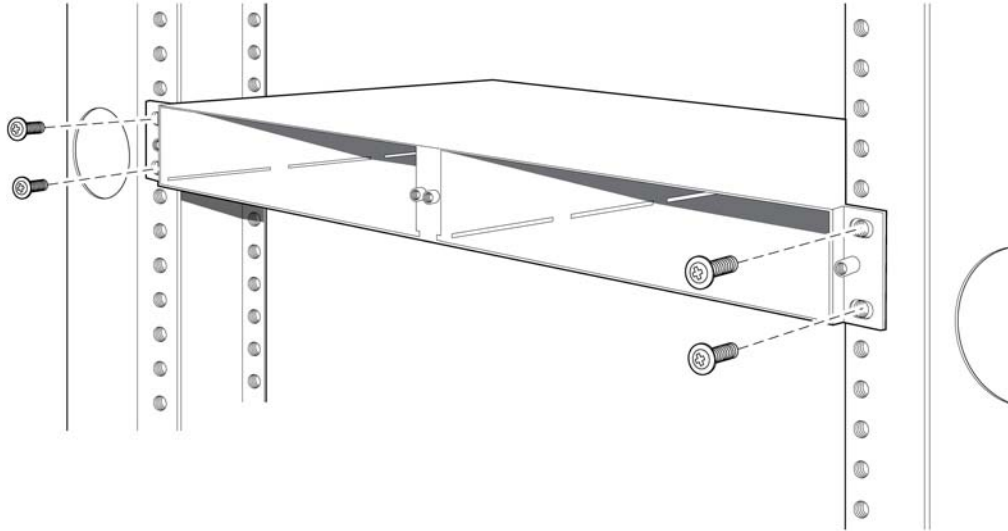

- 4 Carefully slide the CU into the front of the chassis.

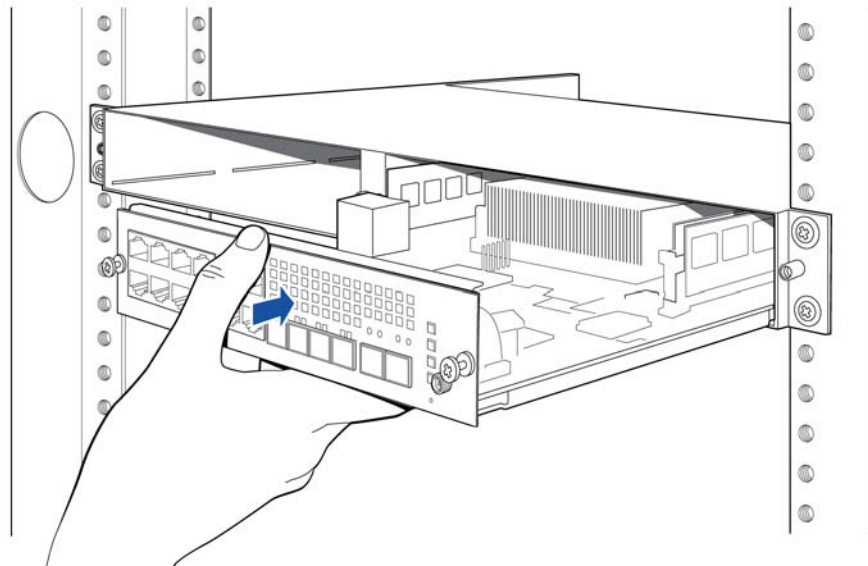

DRAFT

- 5 Secure the CU by tightening the front panel screws.

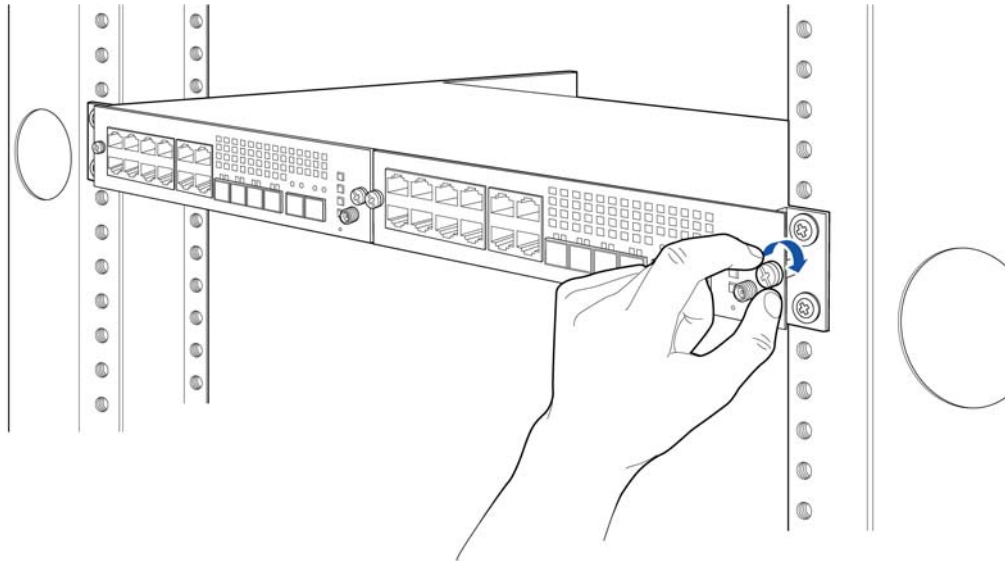

- 6 In the back of the rack, carefully slide the PFU into the back of the chassis.



CAUTION

The PFU has a fan hazard. A label is affixed to the top of the PFU indicating the hazard.

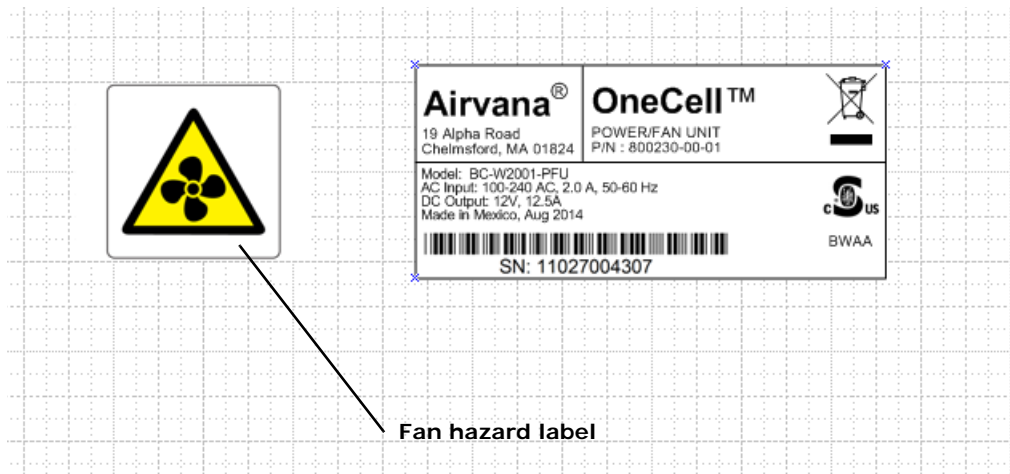

NOTE: The connectors on the PFU should fit easily into the connector on the CU. Do not force the PFU into the chassis.

DRAFT

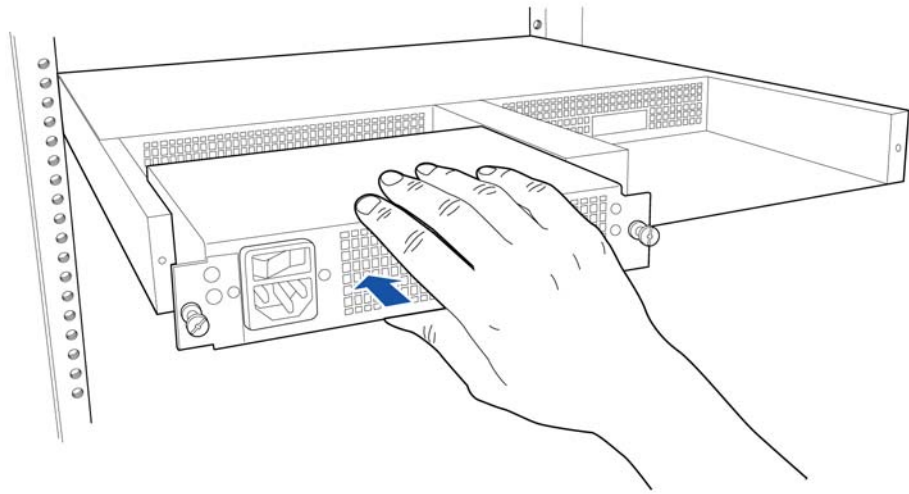

7 Secure the PFU by tightening the thumb screws.

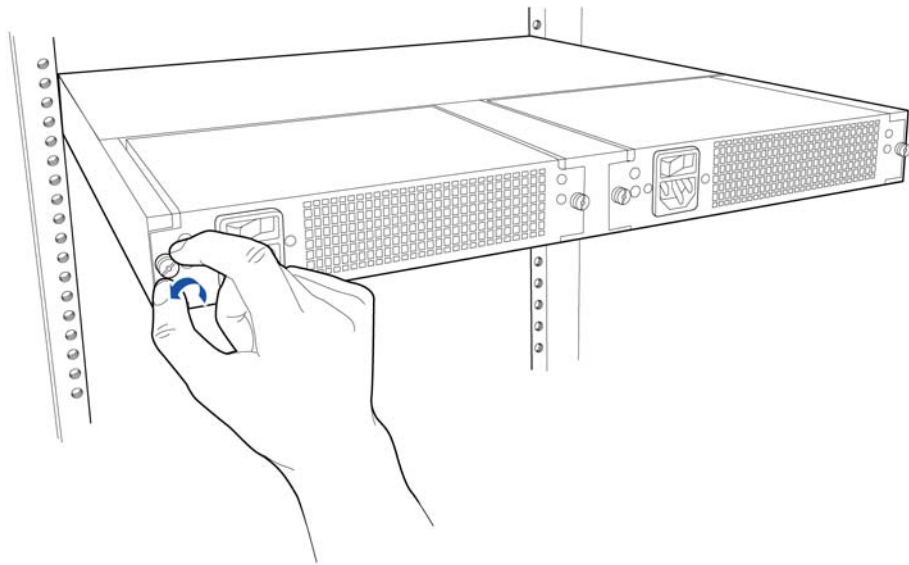

DRAFT

- 8 Connect the power cord to the PFU.

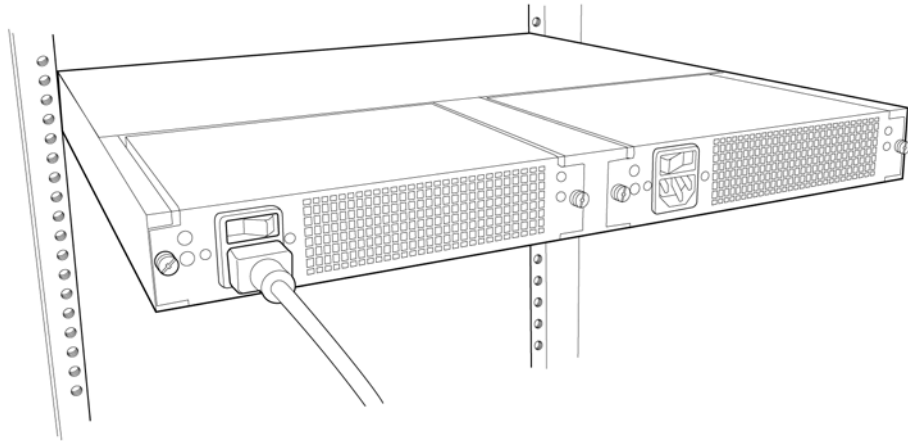

- 9 On the Controller's front panel, connect the GPS antenna cable.

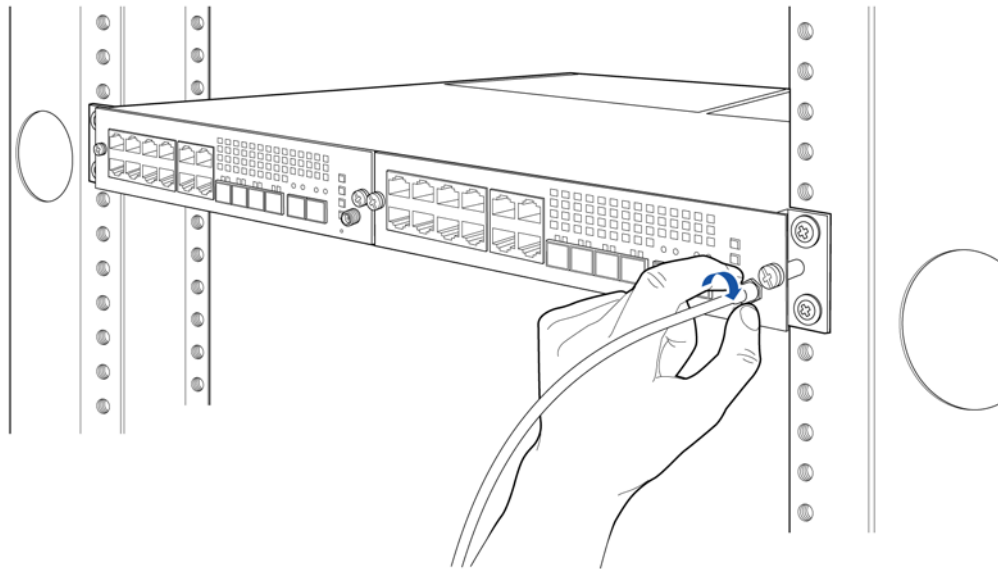

DRAFT

- 10 Connect the Ethernet or fiber optic cable to the appropriate port.

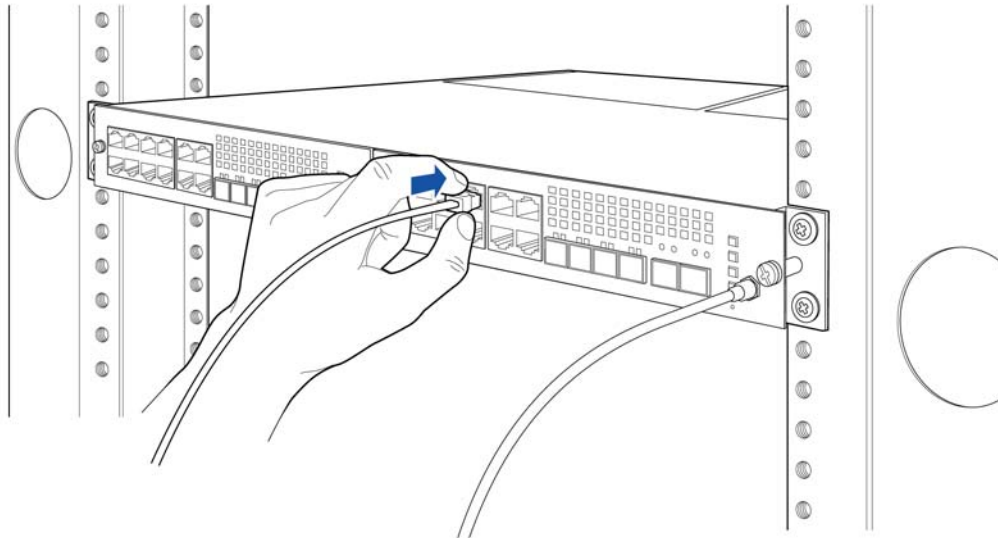

- 11 On the back of the Controller (PFU), turn on the power.

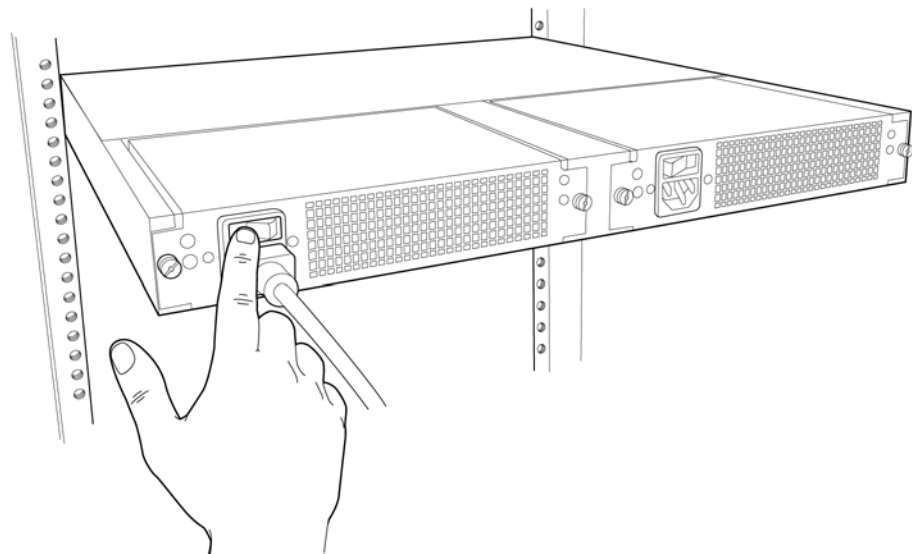

The LEDs on the front panel will be solid green, when the power is on. If none are on, check your power connection. If the LED pattern is other than all green, see [Controller LED patterns](#) on page C-2.

DRAFT

DRAFT

Radio Point Installation

This chapter describes installing Radio Points on ceiling tiles and above ceiling tiles.

Radio Point installation overview	4-2
Ceiling mount	4-2
Flown mount	4-15
Pole mount	4-16

DRAFT

Radio Point installation overview

There are four configurations for installing the Radio Point, which are dependent on the ceiling type.

- Ceiling mount, on tile
- Ceiling mount, above tile
- Flown mount
- Pole mount

Ceiling mount

Mounting the Radio Point (RP) above or on the ceiling tile requires the following hardware provided by Airvana:

- Radio Point plate and screws
- Mounting plate screws

Figure 4-1. Airvana ceiling mount kit contents

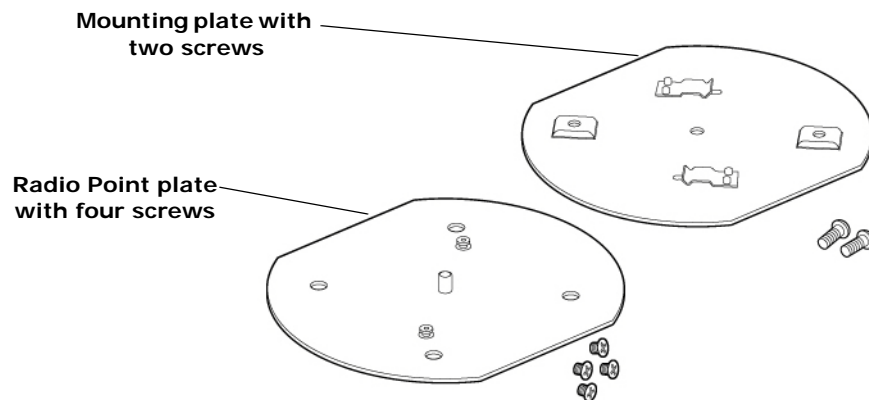

Mounting the Radio Point (RP) above or on the ceiling tile requires the following hardware provided by the system integrator:

- 4" octagon box, 1-1/2" deep with 1/2" side cutouts
- Drop rail – Eaton B-line BA50 recommended
- Clamp
- Mounting screw

DRAFT

Figure 4-2. On-ceiling mounting hardware, system integrator provided

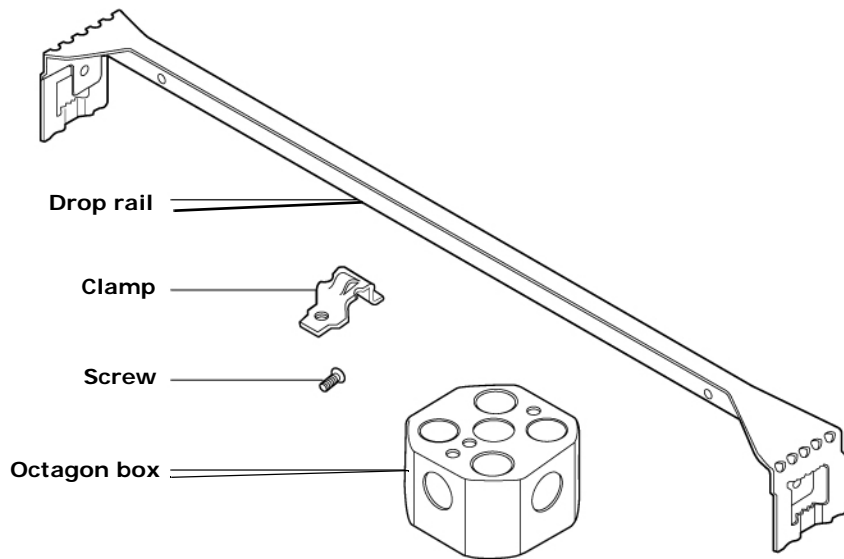
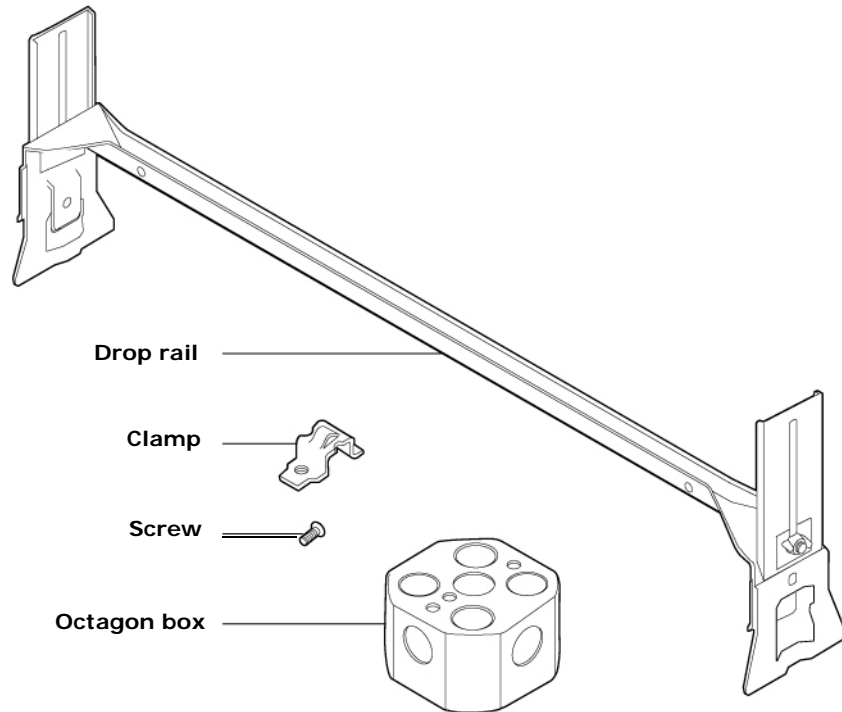

Figure 4-3. Above ceiling mount hardware, system integrator provided



DRAFT

Mounting the Radio Point on the ceiling tile

- 1 Remove ceiling tile from the overhead.

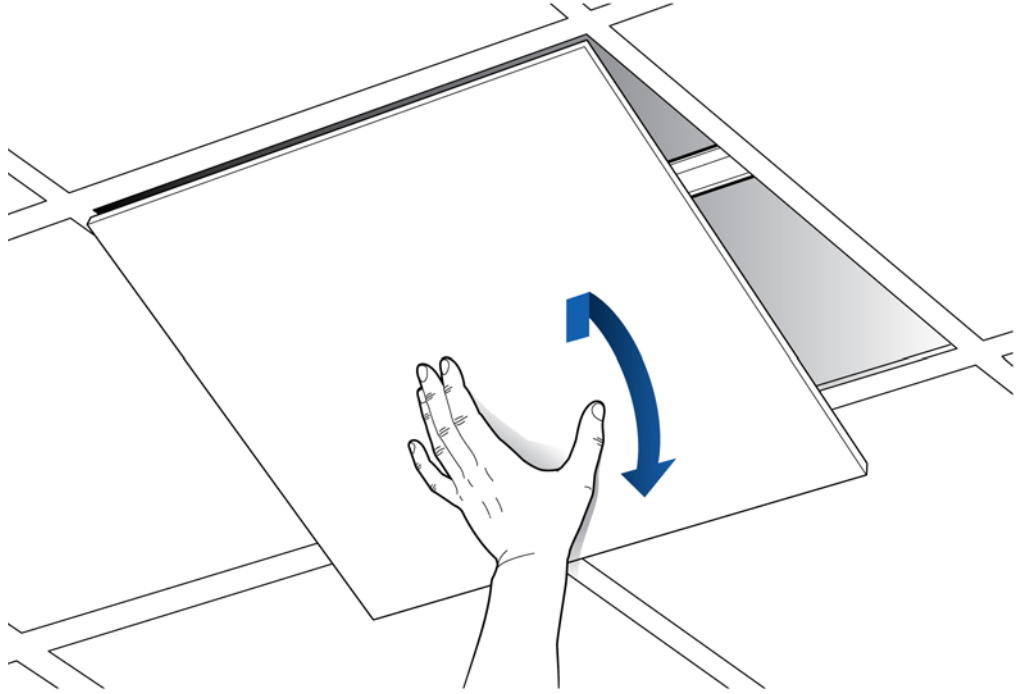

- 2 Cut 5" diameter hole to fit a 4-inch octagon box and drill a 1/2" diameter hole for the Ethernet cable pass-through.

NOTE: Use a 1-1/2 deep RACO 8125 or equivalent.



~~Trace the outline of the octagon box on the ceiling tile.~~
Use the mounting plate as a guide on the ceiling tile.

DRAFT

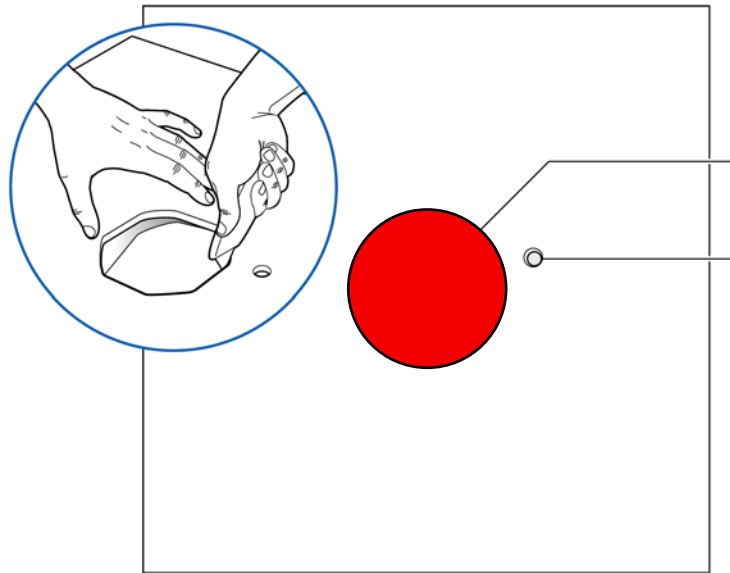

- 3 Attach the octagon box to the ceiling bracket using a clamp and screw.

NOTE: Airvana recommends the Eaton B-line – BA50 bracket.

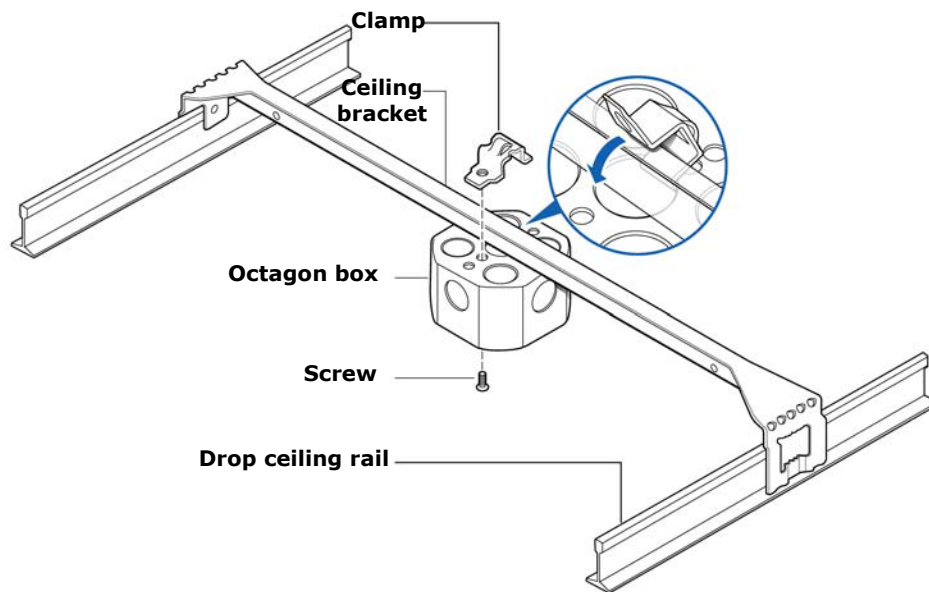

- 4 Attach the mounting plate onto the octagon box.

DRAFT

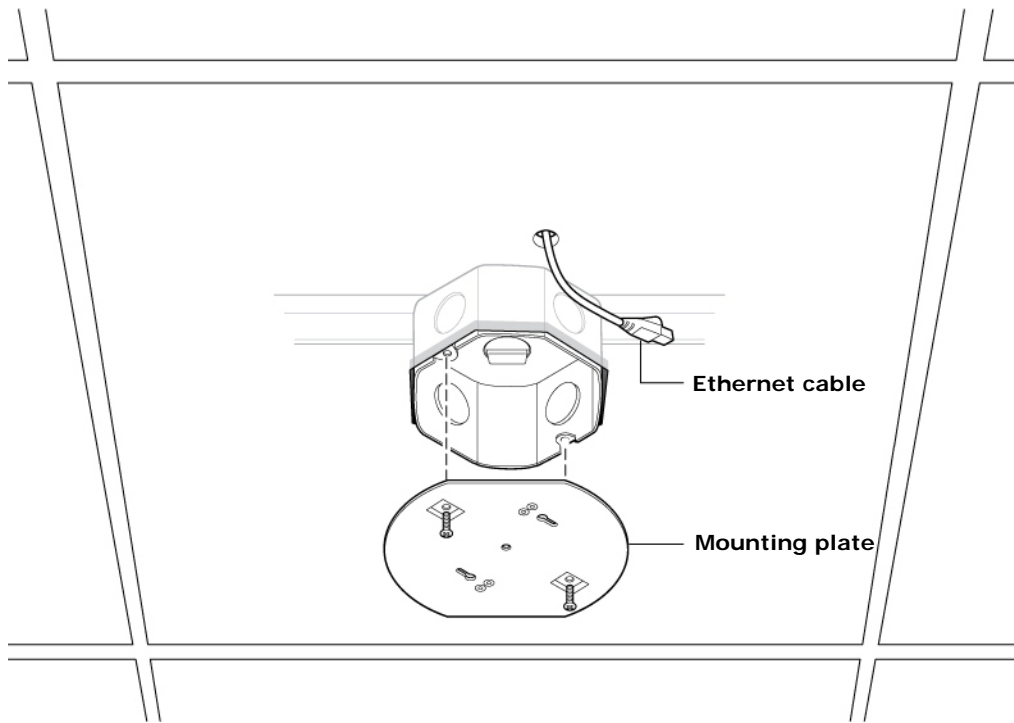

- 5 Replace the ceiling tile and pull the Ethernet cable through the ceiling tile.

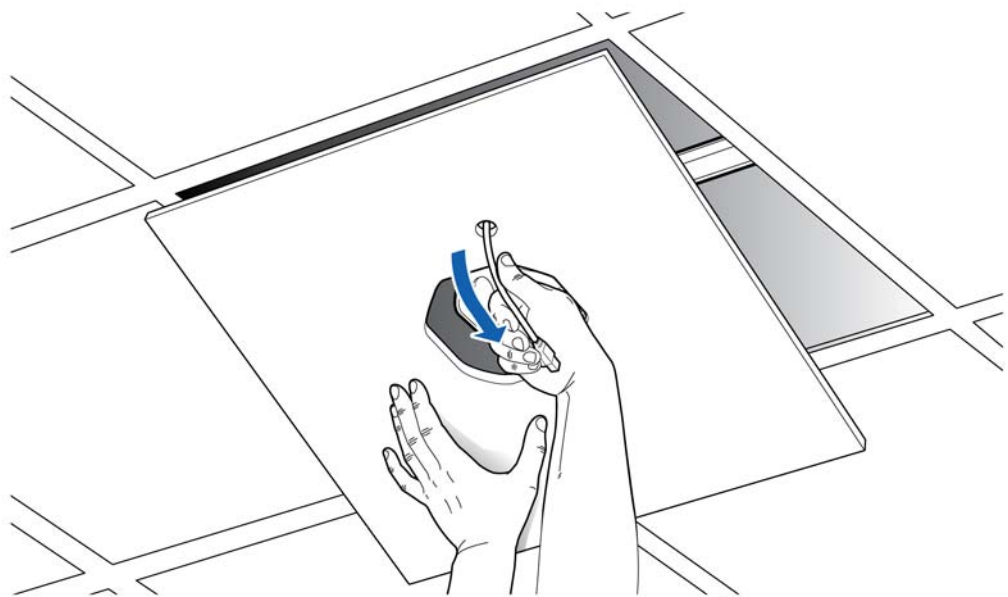

DRAFT

- 6 Attach base plate to the Radio Point. **Apply Thread locking compound to screws prior to installation.**

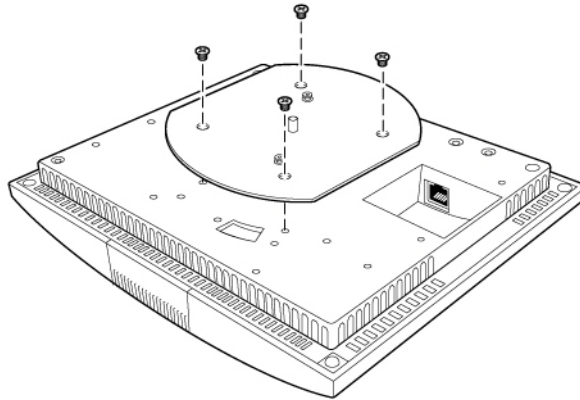

- 7 Attach the Ethernet cable to the Radio Point.

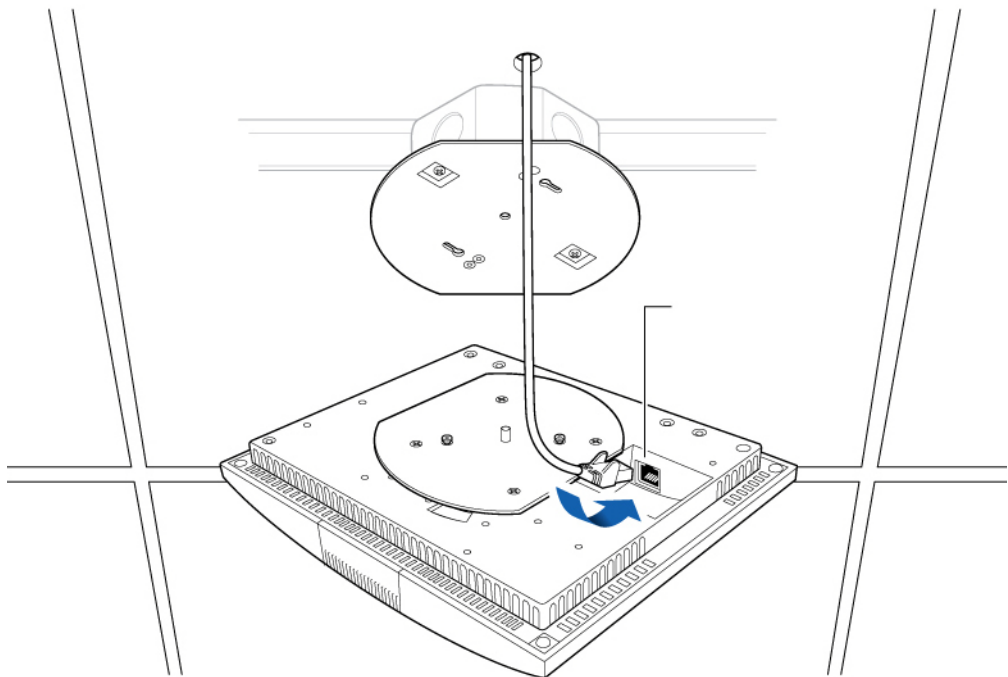

- 8 Mount the Radio Point on the bracket.

DRAFT

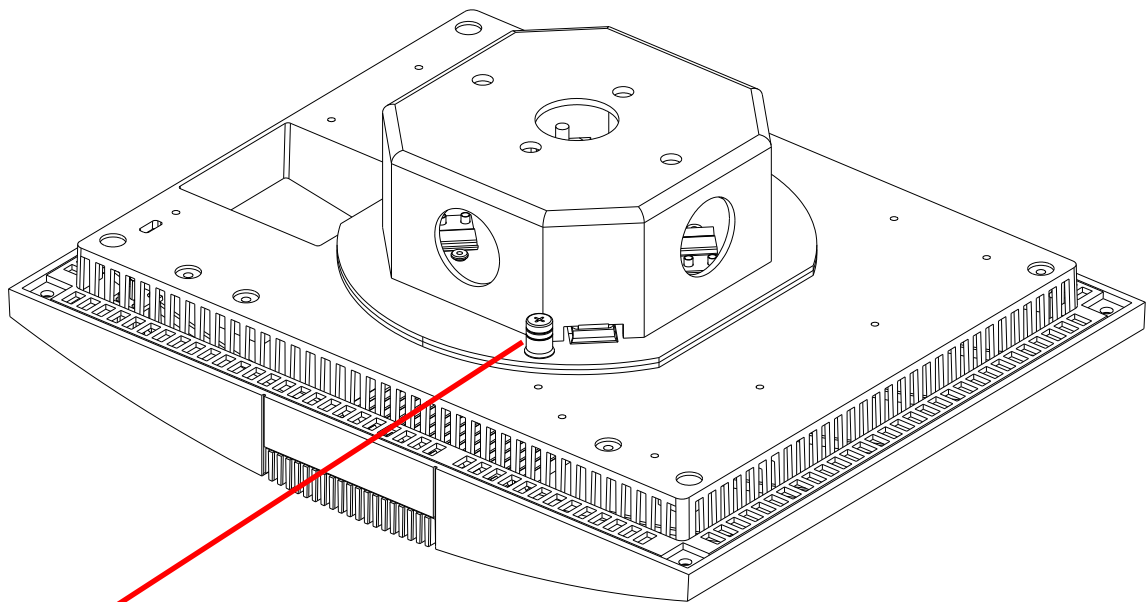
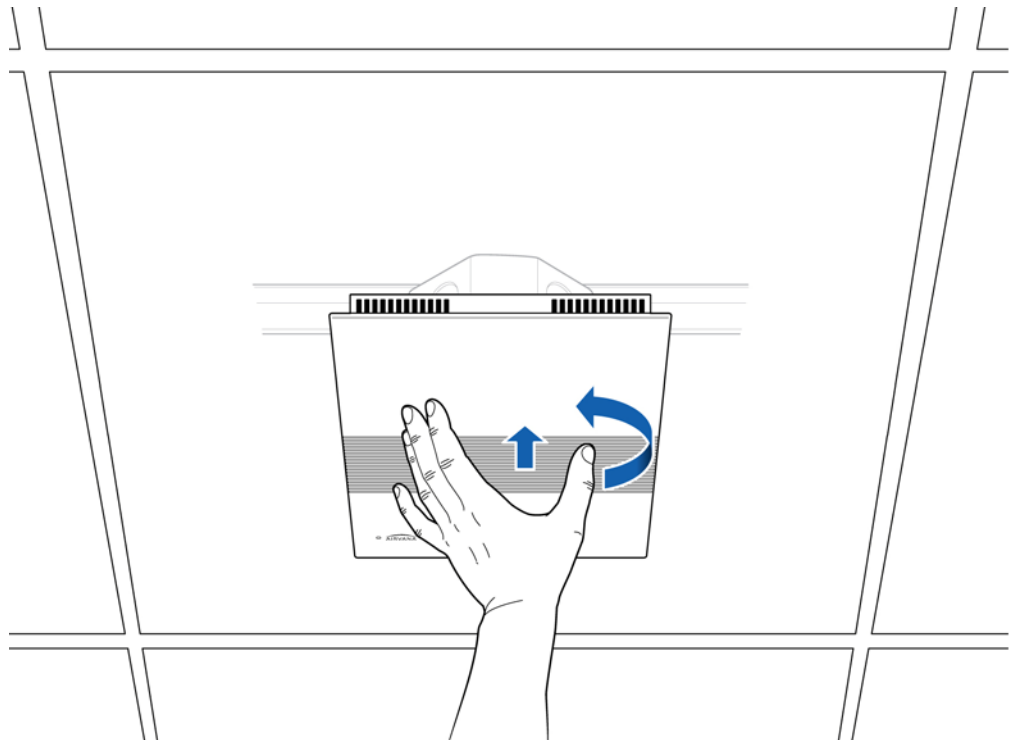

Tighten locking screw after installation of Radio Point

DRAFT

Mounting the Radio Point above the ceiling tile

- 1 Remove ceiling tile from the overhead.

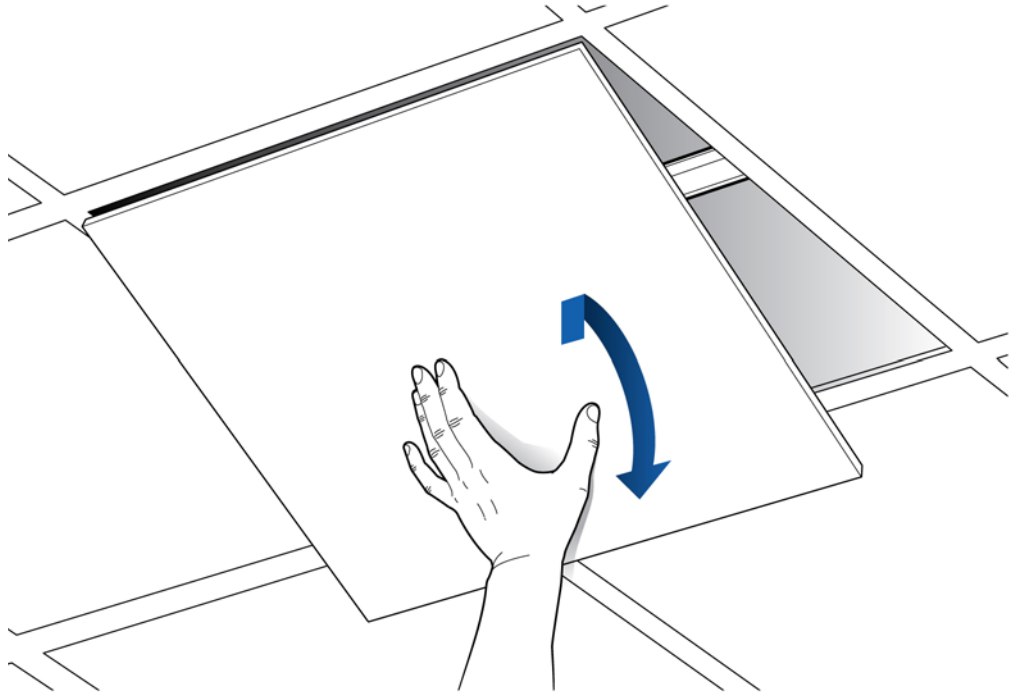

DRAFT

- 2 Attach the bracket to the ceiling tile rail.
- 3 Attach the octagon box to the bracket.

NOTE: Airvana recommends an Eaton B-line – BA50A adjustable bracket.

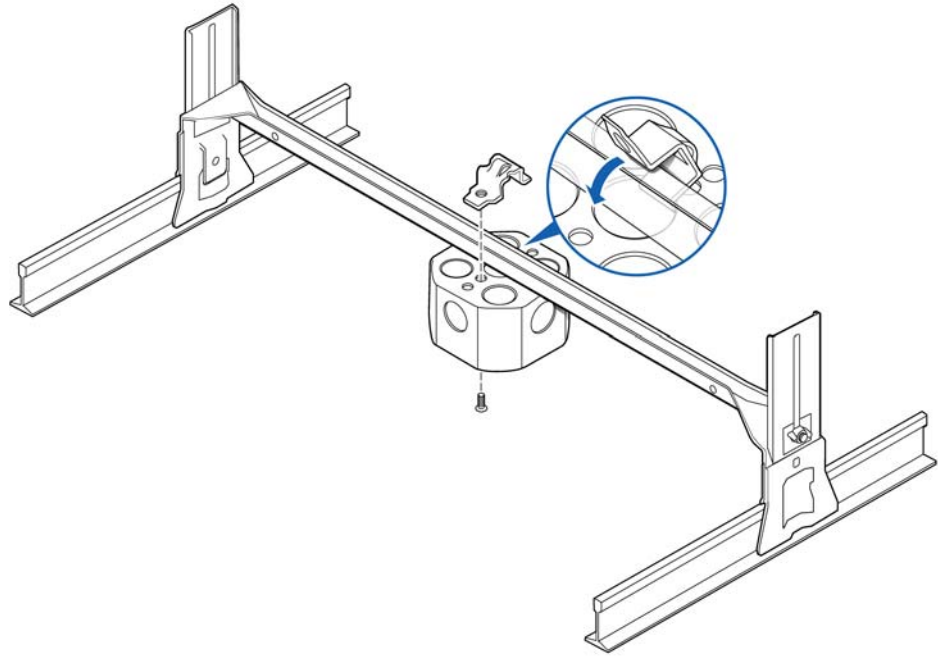

DRAFT

4 Attach the plate to the octagon box.

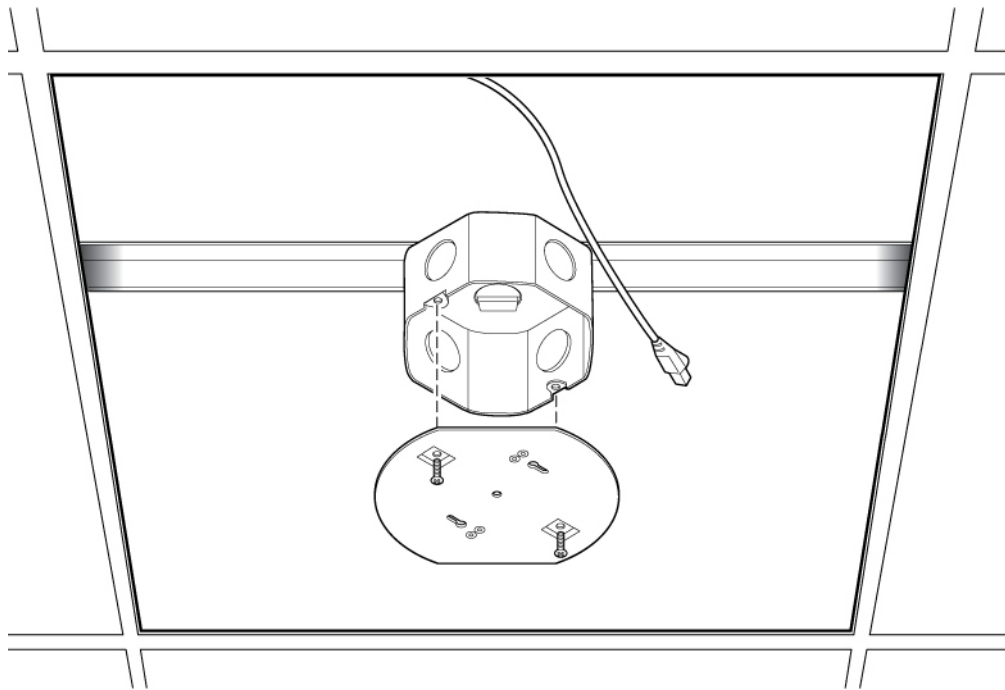

DRAFT

- 5 Attach plate to the Radio Point. Apply Thread locking compound to screws prior to installation.

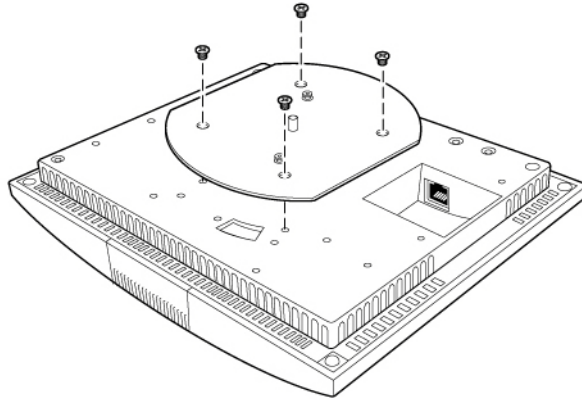

DRAFT

6 Attach the Ethernet cable to the Radio Point.

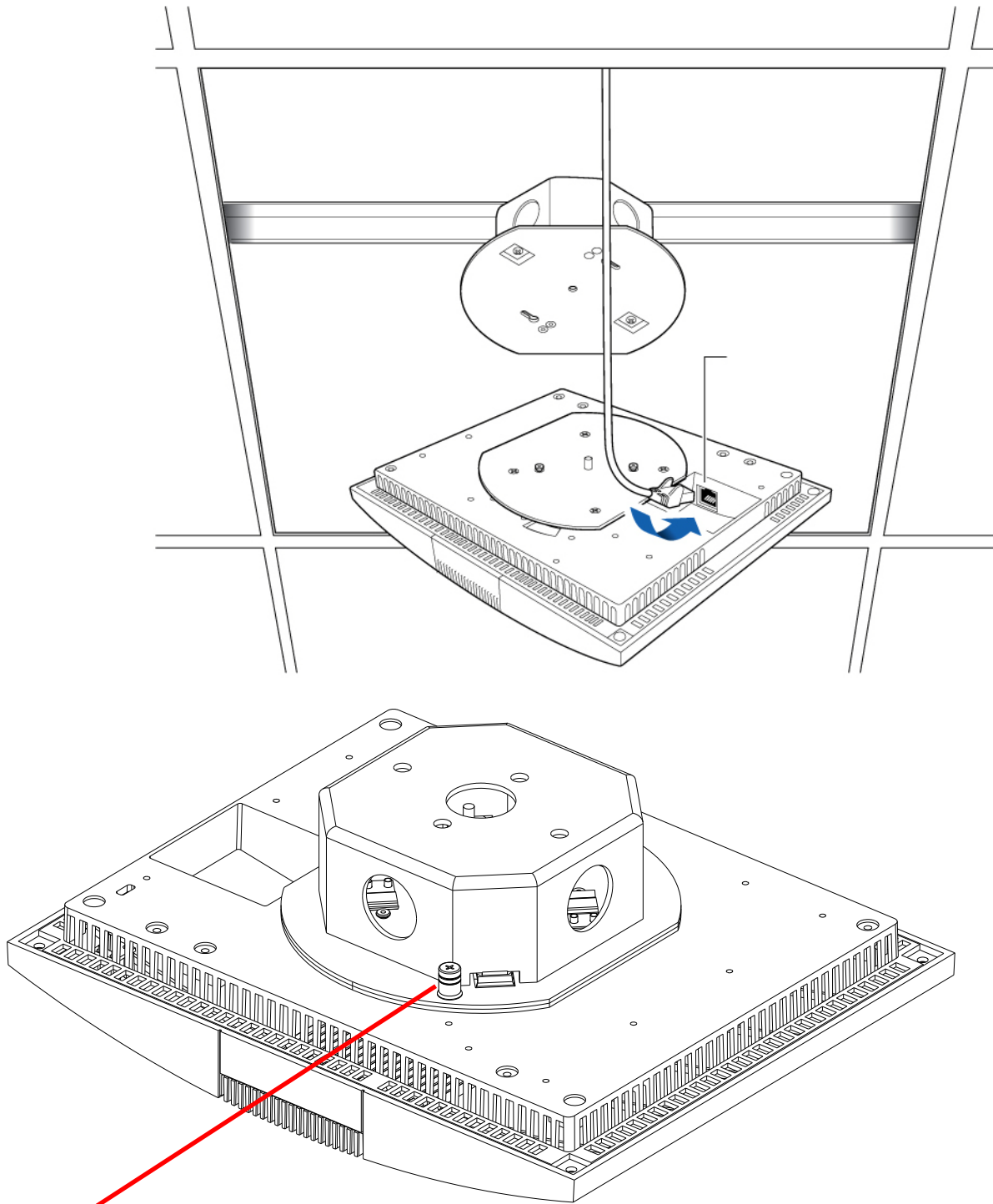

Tighten locking screw after installation of Radio Point

DRAFT

7 Attach the Radio Point to the plate.

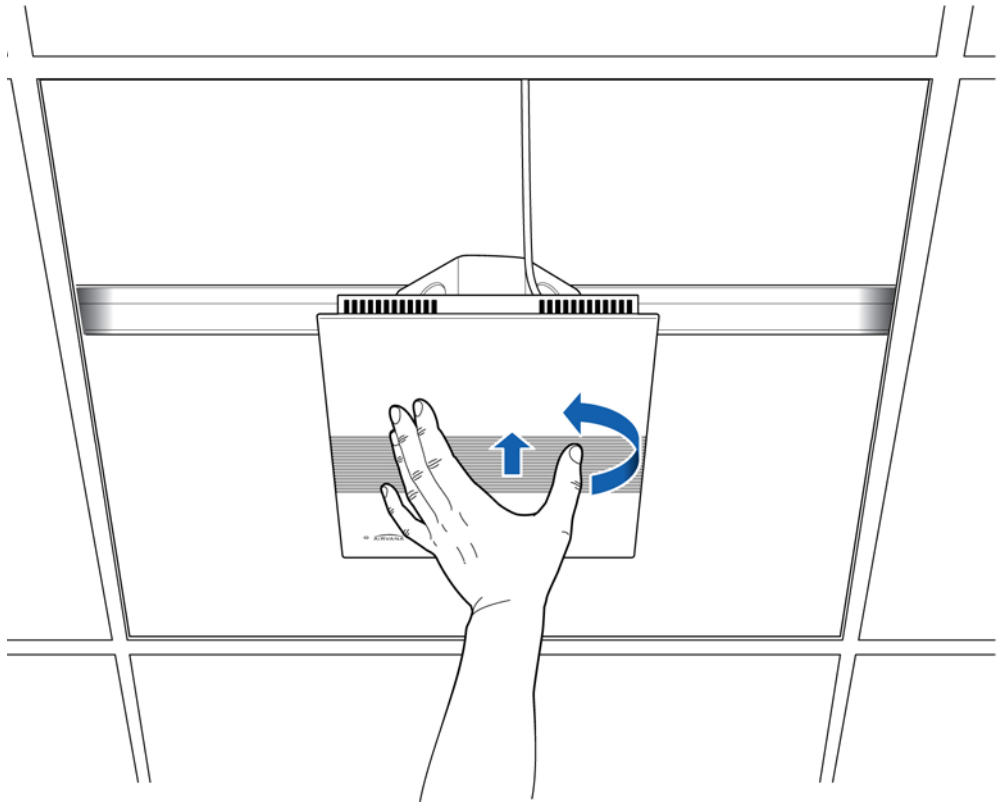

NOTE: The minimum clearance for cooling is 4 inches.

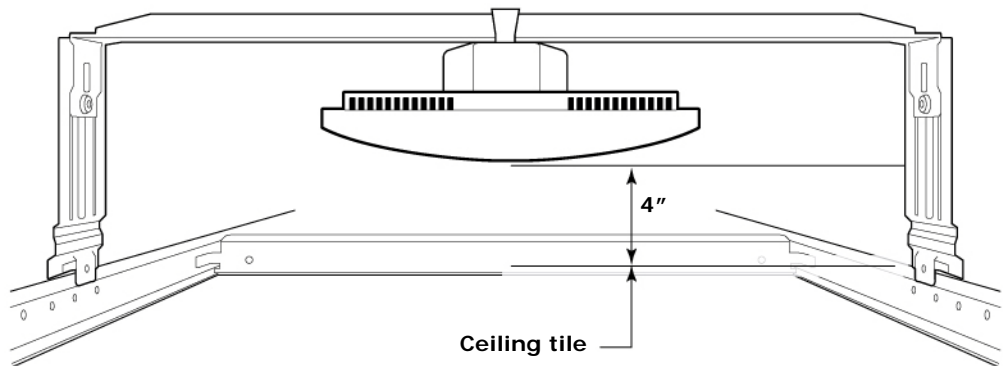

8 Replace the ceiling tile.

DRAFT

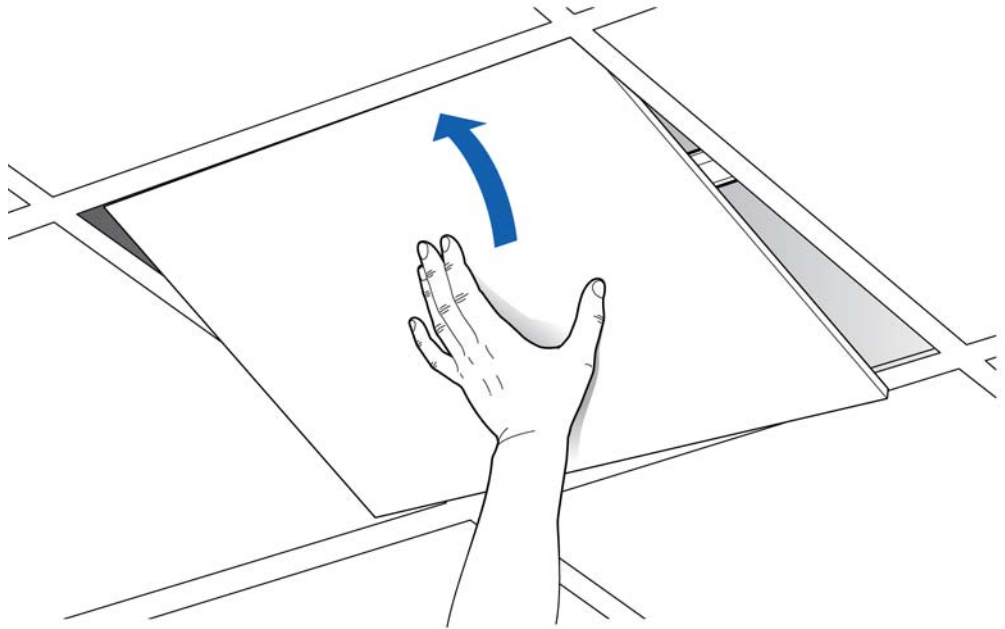

Flown mount

The Radio Point can be flown mounted on the end of a rod. This configuration is used for building where there are no drop ceilings.

Mounting the Radio Point (RP) in the flown configuration requires the following hardware provided by Airvana in the mounting kit:

- Mounting bracket
- Screws

Figure 4-4. Mounting bracket kit contents

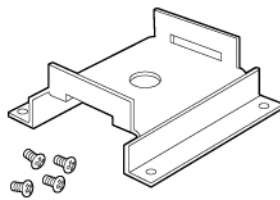

Mounting the Radio Point (RP) in the flown configuration requires the following hardware provided by the system integrator:

DRAFT

- Rod, 3/8-inch threaded
- Nut
- Lock nut, nylon

Flown mount installation

- 1 Attach the threaded, 3/8-inch rod, cut to the required length, to the ceiling.
- 2 Install the nut on the rod.
- 3 Slide the bracket on the rod and install the nylon lock nut.

NOTE: Be sure the bracket is tight between the nuts and there is enough clearance at the end of the rod to attach the bracket to the Radio Point.

- 4 Attach the Airvana-supplied mounting bracket to the Radio Point.

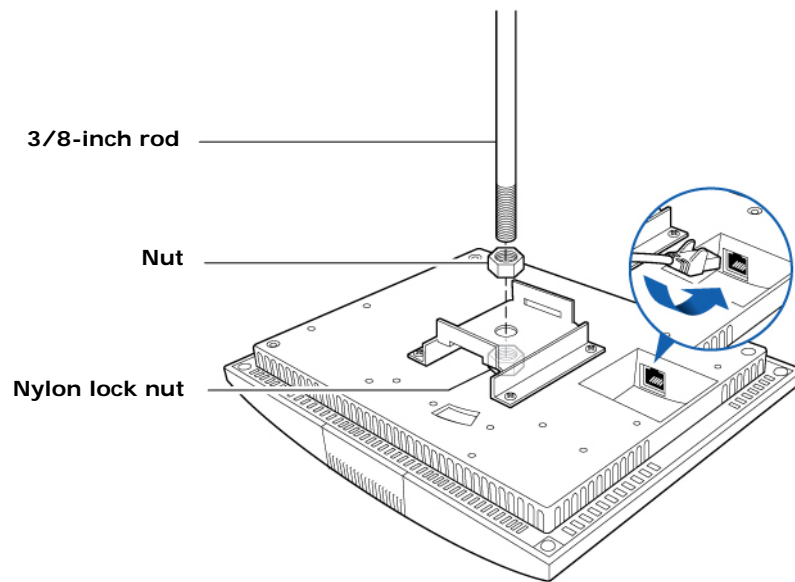

- 5 Connect the Ethernet cable to the Radio Point.

Pole mount

The Radio Point can be pole mounted. This configuration is used for building where there are no drop ceilings.

DRAFT

Mounting the Radio Point (RP) on a pole requires the following hardware provided by Airvana in the mounting kit:

- Mounting bracket
- Screws

Figure 4-5. Mounting bracket kit contents

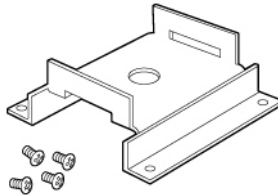

Mounting the Radio Point (RP) on a pole requires the following hardware provided by the system integrator:

- Adjustable clamp at least 2 inches larger than the circumference of the pole

DRAFT

Pole mount installation

- 1 Attach the bracket to the Radio point.

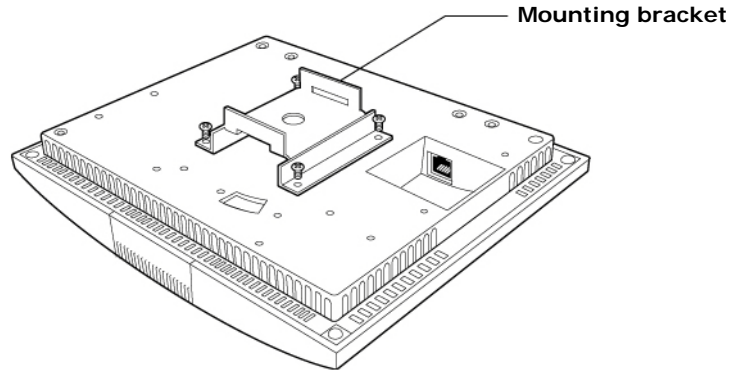

- 2 Slide the adjustable clamp through the slots on the Radio Point bracket.
- 3 Wrap the clamp around the pole and tighten the clamp screw to secure the Radio Point to the pole.

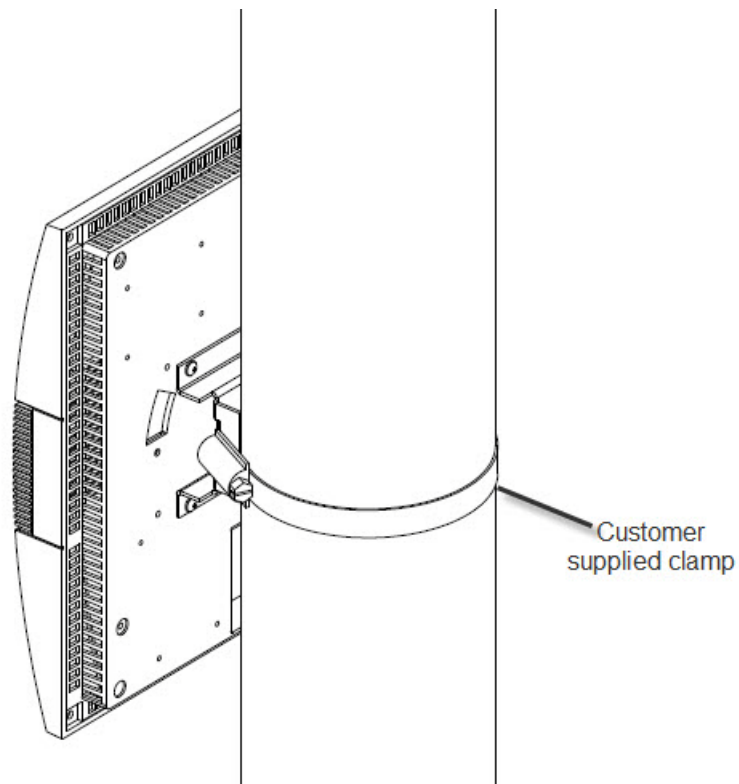

- 4 Connect the Ethernet cable to the Radio Point.

DRAFT

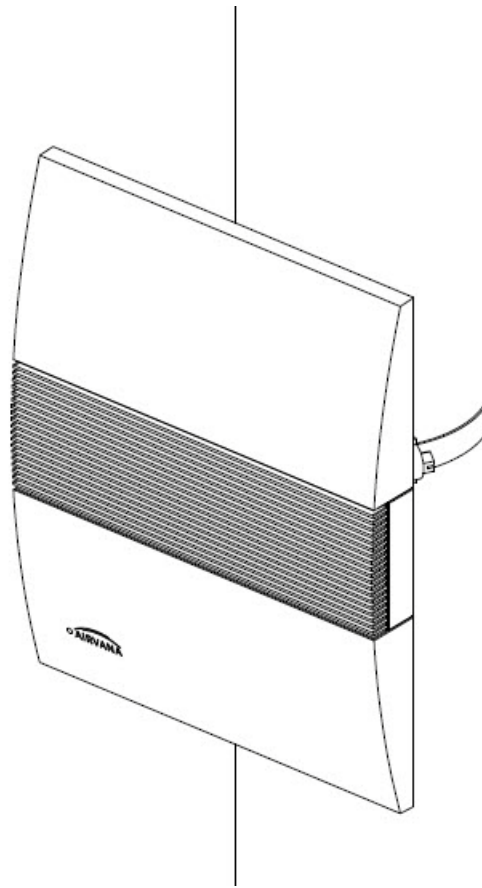
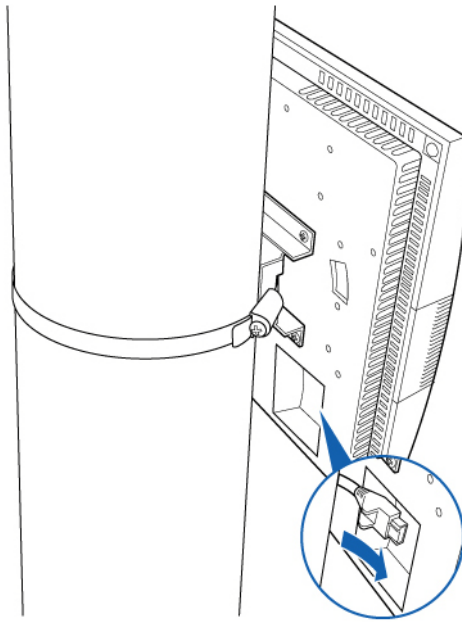

DRAFT

DRAFT

Part III: Appendices

Appendix A Safety

Appendix B Specifications

Appendix C Installation troubleshooting

DRAFT

DRAFT

Safety

This appendix contains specifications for Airvana OneCell, including FCC information and technical data.

FCC Radiation Exposure Statement	A-2
Human exposure limits for OneCell deployments	A-2
Canada Radiation Exposure Statement	A-4

DRAFT

FCC Radiation Exposure Statement

Important: Changes or modifications not expressly approved by Airvana LLC could void your authority to operate the equipment.

This device complies with FCC's RF radiation exposure limits set forth for an uncontrolled environment under the following conditions:

- This device should be installed and operated such that a minimum separation distance of 8 inches (20 cm) is maintained between the radiator (antenna) and the user's or nearby person's body at all times.
- This transmitter must not be co-located or operating in conjunction with any other antenna or transmitter.

For more information, see the publication femtocells and Health at [http:// www.femtoforum.org](http://www.femtoforum.org) or visit the FCC website at www.fcc.gov.

FCC Part 15

This device has been tested and found to comply with the limits for a Class B digital device, pursuant to Part 15 of the FCC Rules. These limits are designed to provide reasonable protection against harmful interference in a residential installation. This device generates, uses, and can radiate radio frequency energy and, if not installed and used in accordance with the instructions, may cause harmful interference to radio communications. However, there is no guarantee that interference will not occur in a particular installation. If this device does cause harmful interference to radio or television reception, which can be determined by turning the device off and on, the user is encouraged to try to correct the interference by one of the following measures:

- Re-orient or relocate the receiving antennas of other devices.
- Increase the separation between the AIRAVE and other device receivers.
- Connect the AIRAVE into an outlet on a circuit different from that to which the other device receiver is connected.
- Consult the dealer or an experienced radio/TV technician for help.

Human exposure limits for OneCell deployments

The human exposure limits for the OneCell product is calculated by using the Maximum Permissible Exposure (MPE) method associated with fixed-type transmitter devices.

[Table A-1](#) includes values for one Radio Point (RP) and four Radio Points per chassis.

DRAFT

Table A-1. RF exposure for OneCell at maximum power internal antennas

Parameter	Value for One RP	Value for Two RPs
Tx Power (dBm) per antenna	23	23
Tx Loss (dB)	0	0
Tx Antenna Gain	2	4
Multi-operator Combiner Loss	0	-6
Transmitter Duty Cycle %	100	100
Number of Antennas (MIMO)	2	2
Contribution due to multiple antennas (dB)	3.010299957	3.010299957
Power Increase due to multiple RPs (dB)	0	6.020599913
Derived Total EIRP (dBW)	-1.989700043	0.03089987
Frequency (MHz)	1900	1900
Point Source Total EIRP (watts)	0.632455532	1.007140329
Target W/m ²	9.5	9.5

Reference documents

[1] Federal Communications Commission Document OET Bulletin 65, Supplement C, 2001, Evaluating Compliance with FCC guidelines for Human Exposure to radio frequency Electromagnetic Fields, US Federal Communications Commission, Office of Engineering and Technology June 2001.

[2] Federal Communications Commission Document OET Bulletin 56, "Questions and answers about biological effects and potential hazards of radio frequency electromagnetic fields", Federal Communications Commission Office of Engineering and Technology, August 1999.

[3] ICNIRP Guidelines for limiting exposure to time varying electric, magnetic and electromagnetic fields up to 300 GHz. International Commission on Non Ionizing Radiation, published in Health Physics 74 (4): 494-522; 1998

[4] ICNIRP Statement on EMF-Emitting New Technologies, International Commission on Non-Ionizing Radiation, published in Health Physics 94 (4):376-392, 2008

[5] 3GPP Document 3GPP TS 36.104 version 10.11.0 Release 10," LTE Evolved Universal Terrestrial Radio Access (E-UTRA); Base Station (BS) radio transmission and reception"

Canadian Compliance Statement

This device complies with Industry Canada license-exempt RSS standard(s). Operation is subject to the following two conditions:

- (1) This device may not cause interference, and
- (2) This device must accept any interference, including interference that may cause undesired operation of the device.

Cet appareil est conforme aux norms CNR exemptes de licence d'Industrie Canada. Le fonctionnement est soumis aux deux conditions suivantes:

- (1) cet appareil ne doit pas provoquer d'interférences et
- (2) cet appareil doit accepter toute interférence, y compris celles susceptibles de provoquer un fonctionnement non souhaité de l'appareil.

Industry Canada Statement

Complies with the Canadian ICES-003 Class B specifications.

Cet appareil numérique de la classe B est conforme à la norme NMB-003 du Canada.

This device complies with RSS 210 of Industry Canada. This Class B device meets all the requirements of the Canadian interference-causing equipment regulations.

Cet appareil numérique de la Classe B respecte toutes les exigences du Règlement sur le matériel brouilleur du Canada

DRAFT

Specifications

This appendix contains specifications for Airvana OneCell, including FCC information and technical data.

Electrical ratings and technical data

B-2

DRAFT

Electrical ratings and technical data

The following table lists the electrical ratings and technical data for the Baseband Controller Unit.

Operating Environment	0 to 40°C, 10 to 90% relative humidity, indoor use only, not for wet environments
Electrical Rating	100 - 230 AC, 2.0A, 50 - 60Hz (auto ranging, no adjustment required)
Dimensions	19" w x 1.75" H x 18.8" D (483mm W x 44.4mm H x 477mm D)
Weight	Single CU 13.1 lbs (5.9 KG), Dual CU 19.1 lbs. (8.7 KG)
Safety	IEC 60950-1 2005 (Second edition) + A1:2009

SPF/SPF+ specifications

The following table lists the SPF and SPF+ specifications required for the Baseband Controller Unit.

1G SFP LC SX Transceiver; 220M to 1K M
1G SFP LC LX transceiver, 550M 10K M
10G SFP+ LC SR Transceiver; Multi mode 26M to 300M
10G SFP+ LC SR Transceiver; Single mode 10K M
10G Direct attach SFP+ cable; Twin ax Cable ; 7M (must be compatible with HP & Cisco switches)

DRAFT

Installation troubleshooting

This section contains information on troubleshooting the OneCell installation. It includes the LED patterns for the Baseband Controller and Radio points.

Controller LED patterns	C-2
Radio Point LED patterns	C-4

DRAFT

Controller LED patterns

The Controller has four LEDs on the front panel. The following table shows

- Display pattern for each LED
- What the pattern indicates
- Action to take, if any, to resolve the issue

LED	Display Pattern	Indicates	Action to Take
STATUS	Green, solid	Power On Sectors up	None
	Amber, solid	Self-test failure	
	Green, blinking	Firmware upgrade	None
	Amber, blinking	Configuring from DMS	
	Red, solid	Error in system - software or hardware issues detected	
RU ERROR	Green, solid	Power On	None
	Amber, solid	Self-test failure	
	Amber, blinking	No Radio Points connected	
	Off	Radio Points connected, firmware upgrade	None
	Red, blinking	Radio Point alarm - PLL state unlock; service impacting alarm from Radio Point	
TIMING LED	Green, solid	Power On, timing	None
	Amber, solid	Self-test failure	
	Amber, blinking	No timing	
	Off	Firmware upgrade	None
	Red, solid	Error	

DRAFT

LED	Display Pattern	Indicates	Action to Take
CORE LED	Green, solid	Power On Connection to MME	None
	Amber, solid	Self-test failure	
	Amber, blinking	No connection to MME IPsec is up	
	Off	Firmware upgrade	None
	Red, blinking	Internet connection IPsec down	
	Red solid	No Internet Interface hardware issues	

DRAFT

Radio Point LED patterns

The Radio Point has one LED on the front cover. The following table shows

- Display pattern for the LED
- What the pattern indicates
- Action to take, if any, to resolve the issue

LED	Display Pattern	Indicates	Action to Take
STATUS	Green, solid	Power On RFTx state is on	None
	Amber, solid	Self-test failure	
	Green, blinking	Firmware upgrade Connected to Controller	None
	Amber, blinking	PLL state – unlock RFTx State – off or suspended L2 path verification failed AdminState – STANDBY	
	Red, blinking	No connection to Controller (http)	
	Red, solid	Error in system – software or hardware issues Interface issues detected AdminState – UNLOCKED	

DRAFT

DRAFT



Airvana
19 Alpha Drive
Chelmsford, MA 01824, USA

Phone:
North America +1 (877) 855-4092 (toll free)
International: +1 (978) 250-3100
Fax: +1 (978) 250-3910
Web: www.airvana.com