

## APPENDIX 5

### USER'S MANUAL OF EUT

The enclosed manual is for the EUT. As you will notice on the preceding page of this manual is the **FCC WARNING** about radio and television interference as per the requirement set forth in Part 15 of the FCC Rules.



## Important Safety Instructions

1. Please read these instructions thoroughly.
2. Please keep this guide for future use.
3. Please disconnect the device from the main supply before cleaning. Do not use any liquid or aerosol spray cleaners. The best for cleaning is a piece of cloth dampened with water.
4. To avoid damage of the device, you should only use accessory parts permitted by the manufacturer.
5. The device must be protected against moisture.
6. To setup the device, it must be put in a stable stand position. Tipping it over or dropping it may cause injuries. Only use safety setup locations and follow the setup instructions of the manufacturer.
7. The ventilation openings are used for air circulation which protect the device against overheating.
8. To connect the device, follow the connected load values of the main supply.
9. Due to electrical safety, the wall socket must be equipped with a non-fused earthed conductor contact.
10. The power cable must be laid in a way that nobody may trip over it. There should also nothing be resting on the cable.
11. All instructions and warning remarks on the device must be followed.
12. If the device will not be used for a long period of time, you should disconnect it from the main supply to avoid overvoltage damage.
13. Any objects or liquid should never enter the device via its openings for air circulation. This could cause a fire or an electric shock.
14. Do not open the device ever. For electrical safety, the device shall be opened by authorized technical service personnel only.
15. If following conditions occur, the device must be disconnected from the main supply, and it must be checked by a qualified service center:
  - a- Power cable or power plug are damaged;
  - b- Liquid has entered the device;
  - c- The device was exposed to moisture;
  - d- The device does not operate according to the user's guide, or you do not achieve any improvement with the aid of this guide;
  - e- The device has dropped and/or the casing is damaged;
  - f- The device shows obvious signs of a defect.
16. For repair, only original spare parts or parts in accordance with the original parts may be used. Use of unsuitable spare parts can cause more damage.
17. Please turn to your service center for all questions concerning service and repair to guarantee the device's performance reliability.
18. The socket outlet must be installed near the equipment to be easily accessible.

117) - US

## FEDERAL COMMUNICATIONS COMMISSION (FCC STATEMENT)

This equipment has been tested and found to comply with the limits for a Class B digital device, pursuant to Part 15 of the FCC Rules. These limits are designed to provide reasonable protection against harmful interference in a residential installation. This equipment generates, uses, and can radiate radio frequency energy, and, if not installed and used in accordance with the instructions, may cause harmful interference to radio communications. However, there is no guarantee that interference will not occur in a particular installation. If this equipment does cause harmful interference to radio or television reception, which can be determined by turning the equipment off and on, the user is encouraged to try to correct the interference by one or more of the following measures:

- Reorient or relocate the receiving antenna;
- Increase the separation between the equipment and receiver;
- Connect the equipment into an outlet on a circuit different from that to which the receiver is connected;
- Consult the dealer or an experienced radio/TV technician for help.

Any changes or modifications not expressly approved by the manufacturers may void the user's authority to operate this equipment.



A shielded-type power cord is required in order to meet the FCC emission limits and also to prevent interference to nearby radio and television reception. It is essential that only the supplied power cord be used.

Use only shielded cables to connect I/O devices to this equipment.



### Canadian DOC Notice

#### For Class B Computing Devices

This Class B digital apparatus meets all requirements of the Canadian Interference-Causing Equipment Regulations.

Cet appareil numérique de la classe B respecte toutes les exigences du Règlement sur le matériel brouilleur du Canada.



# CHAPTER 1

## Introduction

Congratulations on your purchase of the new high performance 17" Monitor. Much consideration has gone into the design of the monitor in order to meet your requirements for full compatibility and versatility as well as quality.

Using state-of-the-art electronics, the monitor can support a resolution of 1280x1024, and the on-screen display allows you to customize the display settings to suit your individual needs. User display settings will be automatically saved to memory. In addition, at the touch of a button the user can, at any time, return to the factory default display settings.

Other ergonomic features include a non-glare screen, tilt and swivel and *just two* multi-function display controls that allow you to make all monitor display adjustments.

## Unpacking

Please make sure the following items are in the shipping package and found in good condition:

- 17" Monitor
- Tilt and swivel stand
- Power cord
- Signal cable (attached to monitor)
- This manual

If any of the above are missing or appear damaged, please contact your dealer immediately.

# Table of Contents

<b>Chapter 1</b>	<b>1</b>
<b>Introduction</b>	<b>1</b>
Unpacking	1
<b>Getting Started</b>	<b>2</b>
Connecting the Monitor and Stand	2
Removing the Monitor and Stand	2
Choosing a Workstation	3
The AC Connection	4
The Signal Cable Connection	4
Monitor Adjustments	5
<b>Chapter 2</b>	<b>6</b>
Adjusting the Brightness and Contrast	7
The On-Screen Display(OSD)	8
Color Temperature Setup	10
OSD Window Status	12
Reset and Degauss	13
Self-Test Screen	13
Summary of OSD Icons	14
<b>Appendix A</b>	<b>16</b>
<b>Technical Information</b>	<b>16</b>
Monitor Specifications	16
<b>Troubleshooting</b>	<b>18</b>



## Getting Started

This chapter covers setting up the monitor and stand in a suitable workplace, and connecting the power cord and signal cable.

### Connecting the Monitor and Stand

1. Align the stand's four tabs with the slots in the bottom of the monitor.
2. Slide the stand toward the front of monitor. After insert the tabs into the slots.
3. Push back of swivel ball with angle 45° slowly. You will hear the spring lock click into place.

### Removing the Monitor and Stand

- ♦ If you need to remove the stand, push the spring lock and slide the stand away from the monitor.

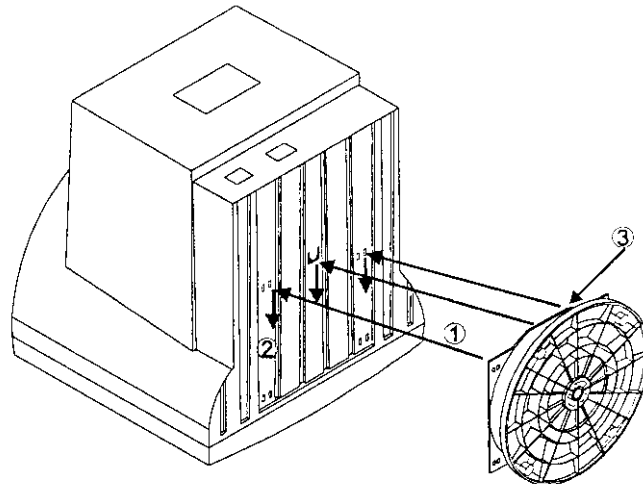

*Figure 1: Monitor and Stand Connection*

**NOTE:**

Special protection on control knobs and LED indicator needs to be taken care while you place the CRT side of side of monitor downwards. Such concern will escape the permanent damage occurred on encoder and LED lens from excessive pressure



## Choosing a Workstation

Keep the following in mind when choosing a work place for the Monitor.

- ◆ Place the monitor on a stable even surface.
- ◆ Access to an electrical outlet.
- ◆ Ensure at least three inches clearance at the rear of the monitor to allow for sufficient airflow.
- ◆ Position the Monitor a little *above* eye-level to reduce neck-strain.
- ◆ Do not place near a window. Exposing the Monitor to direct sunlight for extended periods may damage the unit.
- ◆ You may want to use a desk lamp to adjust the ambient lighting for your viewing comfort.
- ◆ A viewing filter is recommended to reduce eye stress and fatigue.

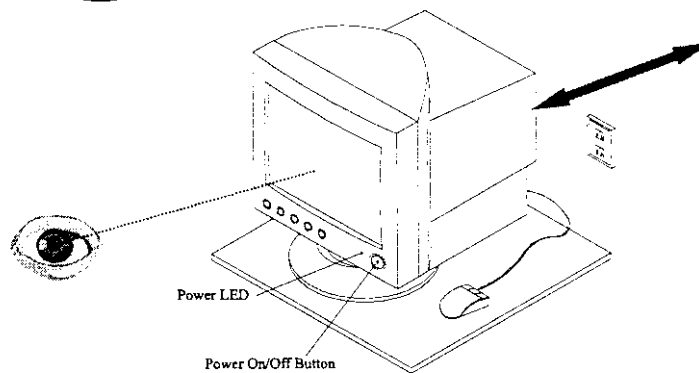
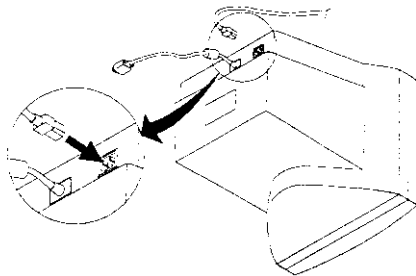

*Figure 2: The Workstation*



## The AC Connection

- Locate the AC port on the rear of the monitor (refer to *Figure 3*).
- Plug the female end of the AC cord into the AC port.
- Plug the male end into the power supply.



*Figure 3: Connecting the Power Cord*

## The Signal Cable Connection

- Make sure that the monitor is powered *Off*. When powered off the Power LED (see *Figure 2*) will not be lit.
- Locate the VGA port on the rear of the PC. The signal cable has a standard 15-pin mini D-sub (VGA) connector. If you are having trouble locating the VGA port, please refer to the documentation, which came with your PC.
- Connect the Signal cable to the PC's VGA port.

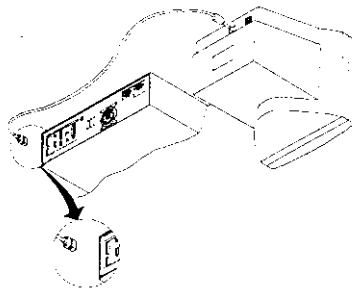

*Figure 4: Connecting the Signal Cable*





## Monitor Adjustments

The monitor is capable of both tilt and swivel adjustments.

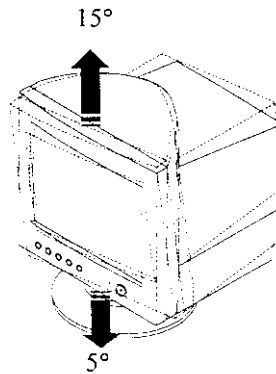

*Figure 5: Tilt Adjustment*

- With the tilt feature, the monitor is capable of vertical adjustments of +15° to -5°.
- The swivel feature allows for horizontal monitor adjustments of +45° to -45°.

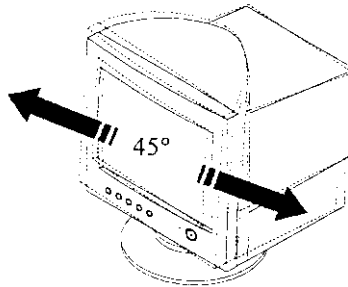
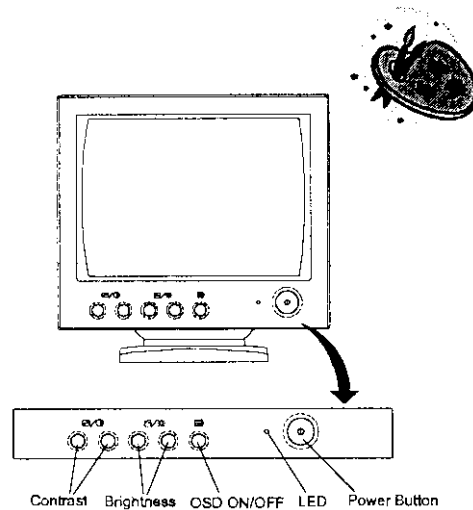

Figure 6: Swivel Adjustment

*This concludes Chapter 1. The next chapter covers the on-screen display (OSD) features.*



*Figure 7*

### **Contrast (and OSD Increase/Decrease) Control**

When the OSD Main Menu is not engaged, Press the *Contrast Control* to adjust the display contrast level to accommodate the ambient lighting conditions of your specific working environment. When the OSD Main Menu is engaged, Press this control adjusts the display-setting values.

### **Brightness (and OSD Function Control) Control**

When the OSD Main Menu is not engaged Press the *Brightness Control* to adjust the display brightness level. When the OSD Main Menu is engaged. Press the control to rotate through the Function options.

### **OSD ON/OFF Control**

When this switch is OFF , the other four controls can be used to adjust the monitor's Brightness and contrast.

When this switch is ON , the OSD Menu appears and OSD Function control can be used.

### **Power LED**

The Power LED informs you of the monitor's current operating status. The Power LED will light *Green* when the monitor is powered On. In Standby mode the LED lights *Amber*. When powered Off the LED is not lit.

### **Power On/Off Button**

Push the Power Button to power the monitor *On* or *Off*.





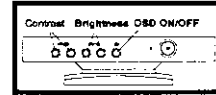
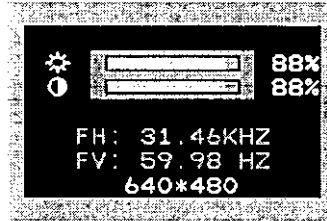

## Adjusting the Brightness and Contrast

To adjust the contrast and/or brightness, Press the *Contrast Control* or the *Brightness Control*, to call up the following on-screen display:







### Brightness



Press the *Brightness Control* right button (  /  ) to increase the brightness. Press the Left button (  /  ) to decrease the brightness. The brightness level is adjusted from 0% to 100%.

### Contrast



Press the *Contrast Control* (  /  ) right button to increase the contrast. Press the (  /  ) left button to decrease the contrast. The contrast level is adjusted from 0% to 100%.

### H. Frequency

**FH:**

This field displays the current Horizontal Scan Frequency. Display only field.

### V. Frequency

**FV:**

This field displays the current Vertical Refresh Rate. Display only field.

### Resolution

**640\*480**

This field shows the display resolution to which your monitor is set. This is a display only field. (Note: It only shows the resolution in presetting mode.)

## The On-Screen Display (OSD)

The monitor features an intuitive, on-screen display (OSD), making changes to the display settings convenient and simple. You can access the OSD any time your PC is powered *On*. If the PC is in *Standby* mode, or is powered *Off*, the OSD cannot be accessed.

To access the OSD Main Menu, push the OSD ON/OFF control button ()  
The following screen will appear:

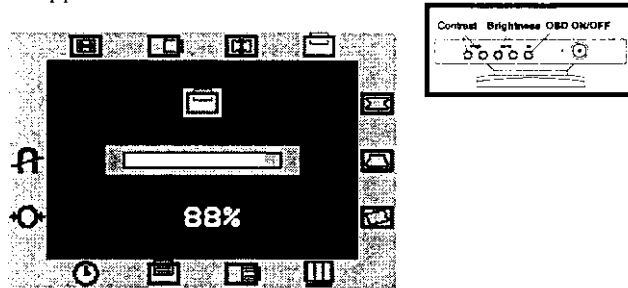

This screen shows the *V-Center* window allowing you to make adjustments to the display's vertical position. Notice the *V-Center* icon in the window border is highlighted.

### Changing Display Settings

Call up the *OSD* as described above. Now press the *Brightness Control* button to scroll through the icons in the window border. You can press the *OSD function or control* () button in the window border by rotating the control in the respective direction.

Once you have selected an icon, use the *Contrast Control* to adjust the option value. Press the right button to increase the value; press the left button to decrease the value.

When making changes to the following settings, a screen similar to the above *V-Center* window will appear on your monitor screen.

*H-Size*



Scroll to the *H-Size* icon. Press the  $\boxed{F23}/\bullet$  button to adjust the horizontal size of the display.

*H-Center*



Scroll to the *H-Center* icon. Press the  $\boxed{F23}/\bullet$  button to position the display along the horizontal axis of the screen.

*V-Size*



Scroll to the *V-Size* icon. Press the  $\boxed{F24}/\bullet$  button to adjust the vertical size of the display.

*V-Center*



Scroll to the *V-Center* icon. Press the  $\boxed{F24}/\bullet$  button to position the display along the vertical axis of the screen.

*Pincushion*



Scroll to the *Pincushion* icon. Press the  $\boxed{F24}/\bullet$  button to adjust pincushion or barrel distortion.

*Trapezoid*



Scroll to the *Trapezoid* icon. Press the  $\boxed{F24}/\bullet$  button to adjust trapezoid distortion.

*Tilt*



Scroll to the *Tilt* icon. Press the  $\boxed{F24}/\bullet$  button to adjust display tilt.



## Color Temperature Setup

To access the Color setup menu, select the *Display Color Setting* icon. The following screen appears:

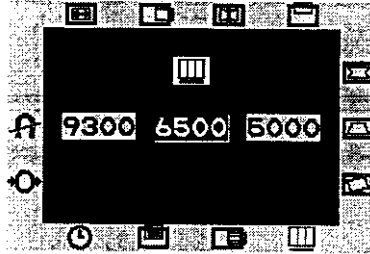

This screen allows you to select a color temperature for your monitor. Press the button to select the desired option. The available options are:

- 9300
- 6500
- 5000

Press the *Brightness function* () Control The following *RGB Gain* window will appear:

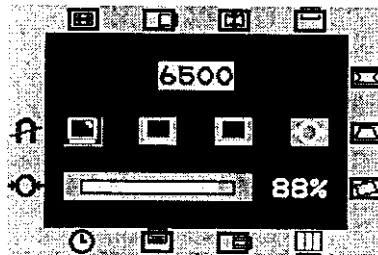

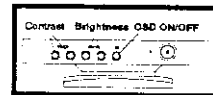

From this window you can make changes to the display's Red, Green and Blue gain. Press the *Brightness Control* to scroll through the options; change values using the button; after making changes, Press the will enter your changes, and move to the next icon.

Values for the *Red, Green or Blue Gain* are displayed from 0% to 100%.



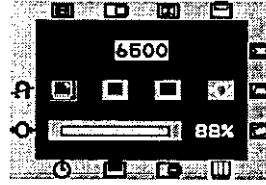

**Red Gain** 

Scroll to the *Red Gain* icon. Press the *Contrast Control*  $\square/\bullet$  to adjust the red gain for your display.

**Green Gain** 

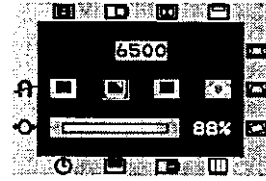
Scroll to the *Green Gain* icon. Press the  $\square/\bullet$  *Contrast Control* to adjust the green gain for your display.

**Blue Gain** 

Scroll to the *Blue Gain* icon. Press the *Contrast Control*  $\square/\bullet$  to adjust the blue gain for your display.

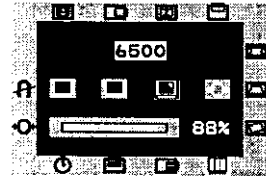
**Reset** 

Scroll to the *Reset* icon. Press the *Contrast Control*  $\square/\bullet$  to reset all three gain values to the default settings. The OSD window will close.

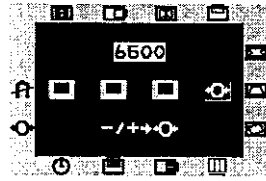



## OSD Window Status

The OSD Window status icons allow you to adjust the position of the OSD window on your screen. You can also set the time that the OSD window will be displayed on the screen.

### OSD Horizontal Position

Scroll to the *OSD Horizontal Position* icon. Press the *Contrast Control*  to adjust the horizontal position of the OSD on the screen.

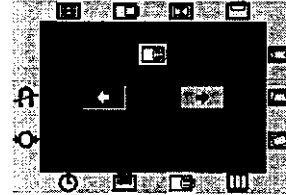

### OSD Vertical Position

Scroll to the *OSD Vertical Position* icon. Press the *Contrast Control*  to adjust the vertical position of the OSD on the screen.

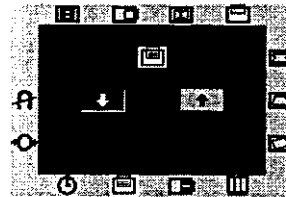

### OSD Display Close Time

Scroll to the *OSD Display Close Time* icon. Press the *Contrast Control*  to set the amount of time that elapses before the OSD closes. Countdown can be set from 5 to 60 seconds.

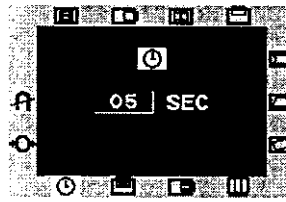

Don't be rushed when changing display settings: The *Display Close Time* does not begin countdown while you are making display adjustments.





## Reset and Degauss

The Reset All option allows you to reset all display settings to their default values. Use the Degauss option to remove unwanted magnetism from the monitor's CRT.

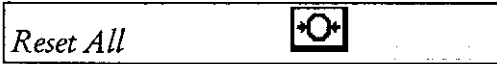

Scroll to the *Reset All* icon. Press the *Contrast Control*  $\square/\bullet$  to reset all display options. If you do not wish to reset all display options, press the *OSD ON/OFF Control* to close the OSD window.

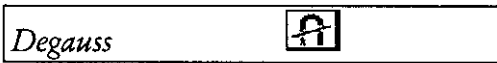
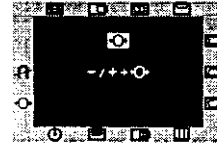

Scroll to the *Degauss* icon. Press the *Contrast Control*  $\square/\bullet$  to degauss the CRT. If you do not wish to degauss the CRT, press the *OSD ON/OFF Control* to close the OSD window.







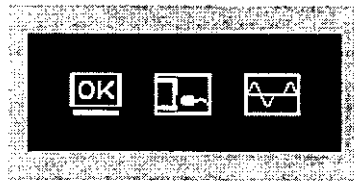

## Self-Test Screen

When the monitor is powered On, but there is no video signal, the following self-test screen will appear.



This screen indicates the monitor itself is OK. If this screen appears, it is possible that the monitor's VGA cable is not connected properly to your computer's VGA port. Check the connection.

If the VGA cable is properly connected but the monitor screen is blank, (i.e., there is no picture and none of the above icons appear), then there may be a problem with the monitor.

Icon	Function	Description
	Blue Gain	Use this option to adjust the blue gain.
	Reset	This option allows you to reset the three color settings to the default value.
	OSD Horizontal Position	Select this option to adjust the horizontal position of the OSD on the screen.
	OSD Vertical Position	Select this option to adjust the vertical position of the OSD on the screen.
	OSD Display Close Time	Use this option to set the amount of time that elapses before the OSD closes.
	Reset All	Use this option to reset all display settings to their default values.
	Degauss	The Degauss option removes unwanted magnetism from the monitor's CRT.

This concludes Chapter 2. The following appendix provides details on your monitor's technical specifications. You will also find tips on troubleshooting any problems you may run into.

# APPENDIX A

## Technical Information Monitor Specifications

---

<b>Screen</b>	
Size	17" CRT
Dot Pitch (mm)	0.28
Surface	Non-glare
Viewable Display Area (mm)	300 x 225
<b>Input Signal</b>	
Video Syn.	RGB Analog 0.7Vp-p/75Ohm a. Separate H/V, TTL (+/-) b. Composite H+V, TTL (+/-)
<b>Scanning Frequency</b>	
Horizontal (KHz)	30-70
Vertical (Hz)	50-120
Video Bandwidth	110MHz
Max. Resolution	1280 x 1024
<b>Compatibility</b>	
IBMVGA, VESA VGA, ERGOVGA, SVGA, UVGA and XGA modes.	
<b>Plug &amp; Play</b>	DDC1 & DDC2B
<b>USB Solution</b>	Optional
<b>External Stereo Speakers</b>	Optional
<b>Display Colors</b>	Unlimited
<b>Signal Cable</b>	
Captive 15 pin, mini D-sub	
<b>Power</b>	
Consumption	110W for normal tubes 115W for low radiation tubes
Supply	100-240VAC 50/60Hz
Power Management	
Power Factor control	Optional
Complies with EPA *, VESA DPMS & TCO *	
<b>On Screen Display</b>	
Brightness	Yes
Contrast	Yes
H/V Size	Yes
H/V Center	Yes
Pincushion	Yes
Tilt	Yes
Trapezoid	Yes
Degaussing	Yes
OSD Position Adjustment	Yes
OSD Close Time	Yes
RGB Gain	Yes

---

---

Color Temperature	Yes
Reset All	Yes
<b>Display Modes</b>	
Preset	6
User	28
<b>Low Radiation</b>	
	MPR II TCO Optional
<b>Operating Range</b>	
Temperature	0-40°C
Relative Humidity	10%-90%
Altitude	Sea level to 8,000ft
<b>Dimensions (including stand)</b>	
412mm(L) x 404mm (W) x 420 mm (H)	
<b>Weight</b>	
Net 16.8kg (37 lb)	

**Preset Timing**

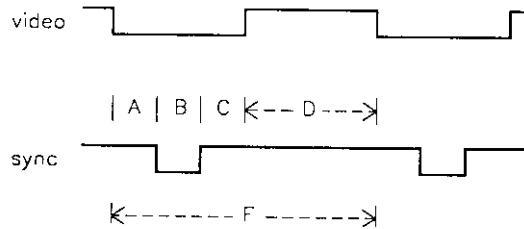

**Preset mode timing**

Figure 8

	MODE	H Pixels V Lines	Fd (MHz)	Fh (KHz)	Th (us)	Td (us)	Tb (us)	Tp (us)	Tf (us)
			Polar (H/V)	Fv (Hz)	Tv (nis)	Td (ms)	Tb (ms)	Tp (ms)	Tf (ms)
1	IBM VGA	640 480	25.175 N/N	31.47 59.94	31.778 16.683	25.422 15.253	1.907 1.048	3.813 0.064	0.636 0.318
2	VESA	800 600	49.5 P/P	46.874 75	21.333 13.333	16.162 12.8	3.232 0.448	1.616 0.064	0.323 0.021
3	VESA	800 600	56.25 p/p	53.674 85.061	18.631 11.756	14.222 11.179	2.702 0.503	1.138 0.056	0.569 0.018
4	VESA (Primary)*	1024 768	78.75 P/P	60.023 75.029	16.66 13.328	13.003 12.795	2.235 0.466	1.219 0.05	0.203 0.017
5	VESA	1280 1024	10X P/P	63.981 60.02	15.63 16.661	11.852 16.065	2.296 0.594	1.037 0.047	0.444 0.016
6	VESA	1024 768	94.5 P/P	68.677 84.997	14.361 11.765	10.836 11.183	2.201 0.524	1.016 0.044	0.508 0.015

Figure 9

Note:

\* Primary mode is the key timing which is adjusted and compliant to the product specification during the production at the factory.

All other preset timings are secondary and adjusted roughly within the range of product nature. It may require a fine tune to gain optimal settings. for user's application.

## Troubleshooting



This section will try to anticipate potential problems that you may encounter in the day-to-day use of your monitor. Included in this section is information which should help solve these problems for you. If after trying the suggested solutions, your monitor's symptom remains the same, contact your authorized service center.

Symptoms	Solution
The monitor is switched on, but the power LED is not lit.	Check to make sure that the power cord is properly connected. If the monitor is plugged into a powered extension cord or a surge protector, make sure that extension cord or the surge protector is turned on
The LED light is on but there is no display on the monitor's screen.	Make sure that the computer's switch is in the "On" position. Make sure that the video cable's D-shaped connector is properly connected to the video adapter port on the back of the PC. Check to make sure that the brightness and contrast control are not turned to their dimmest position.
The display image is either dangling or unstable.	Make sure that the video cable's D-shaped connector is properly connected to the video adapter port on the back of the PC.
The picture is bouncing or a wave pattern is present in the display.	Move any electrical devices away from the monitor which may cause display interference. Please refer to the FCC statement at the beginning of the manual for more details on display interference.