

**COMPAQ**

User's Manual



5525B/31/32 Line Matrix Printer

## READ THIS SOFTWARE LICENSE AGREEMENT BEFORE USING THIS PRINTER

### Software License Agreement

CAREFULLY READ THE FOLLOWING TERMS AND CONDITIONS BEFORE USING THIS PRINTER. USING THIS PRINTER INDICATES YOUR ACCEPTANCE OF THESE TERMS AND CONDITIONS. IF YOU DO NOT AGREE TO THESE TERMS AND CONDITIONS, PROMPTLY RETURN THE PRINTER AND ALL ACCOMPANYING HARDWARE AND WRITTEN MATERIALS TO THE PLACE YOU OBTAINED THEM, AND YOUR MONEY WILL BE REFUNDED.

#### Definitions.

"Software" shall mean the digitally encoded, machine-readable data and program. The term "Software Product" includes the Software resident in the printer and its documentation. The Software Product is licensed (not sold) to you, and Compaq either owns or licenses from other vendors who own, all copyright, trade secret, patent and other proprietary rights in the Software Product.

#### License.

1. Authorized Use. You agree to accept a non-exclusive license to use the Software resident in the printer solely for your own customary business or personal purposes.
2. Restrictions.
  - a. To protect the proprietary rights of Compaq, you agree to maintain the Software Product and other proprietary information concerning the typefaces in strict confidence.
  - b. You agree not to duplicate or copy the Software Product.
  - c. You shall not sublicense, sell, lease, or otherwise transfer all or any portion of the Software Product separate from the printer, without the prior written consent of Compaq.
  - d. You may not modify or prepare derivative works of the Software Product.
  - e. You may not transmit the Software Product over a network, by telephone, or electronically using any means; or reverse engineer, decompile or disassemble the Software.
  - f. You agree to keep confidential and use your best efforts to prevent and protect the contents of the Software Product from unauthorized disclosure or use.
3. Transfer. You may transfer the Software Product with the printer, but only if the recipient agrees to accept the terms and conditions of this Agreement. Your license is automatically terminated if you transfer the Software Product and printer.

#### Limited Software Product Warranty

Compaq warrants that for ninety (90) days after delivery, the Software will perform in accordance with specifications published by Compaq. Compaq does not warrant that the Software is free from all bugs, errors and omissions.

#### Remedy

Your exclusive remedy and the sole liability of Compaq in connection with the Software is replacement of defective software with a copy of the same version and revision level.

### Disclaimer of Warranties and Limitation of Remedies

1. THE PARTIES AGREE THAT ALL OTHER WARRANTIES, EXPRESS OR IMPLIED, INCLUDING WARRANTIES OF FITNESS FOR A PARTICULAR PURPOSE AND MERCHANTABILITY ARE EXCLUDED.  
Compaq does not warrant that the functions contained in the Software will meet your requirements or that the operation of the Software will be uninterrupted or error free. Compaq reserves the right to make changes and/or improvements in the Software without notice at any time.
2. IN NO EVENT WILL COMPAQ BE LIABLE FOR LOST PROFITS, LOST DATA, BUSINESS INTERRUPTIONS, OR ANY OTHER DIRECT, INDIRECT, INCIDENTAL OR CONSEQUENTIAL DAMAGES ARISING OUT OF THE USE OF OR INABILITY TO USE THIS PRODUCT, EVEN IF COMPAQ HAS BEEN ADVISED OF THE POSSIBILITY OF SUCH DAMAGES, OR ANY DAMAGES CAUSED BY THE ABUSE OR MANIPULATION OF THE SOFTWARE. SOME STATES DO NOT ALLOW THE EXCLUSION OR LIMITATION OF LIABILITY FOR CONSEQUENTIAL OR INCIDENTAL DAMAGES, SO THE ABOVE LIMITATION MAY NOT APPLY TO YOU.
3. Compaq will not be liable for any loss or damage caused by delay in furnishing a Software Product or any other performance under this Agreement.
4. Our entire liability and your exclusive remedies for our liability of any kind (including liability for negligence except liability for personal injury caused solely by our negligence) for the Software Product covered by this Agreement and all other performance or nonperformance by us under or related to this Agreement are limited to the remedies specified by this Agreement.
5. California law governs this Agreement.

#### Termination of License Agreement

This License shall continue until terminated. This license may be terminated by agreement between you and Compaq or by Compaq if you fail to comply with the terms of this License and such failure is not corrected within thirty (30) days after notice. When this License is terminated, you shall return to the place you obtained them, the printer and all copies of the Software and documentation.

#### U.S. Government Restricted Rights

Use, duplication or disclosure by the Government is subject to restrictions as set forth in the Rights in Technical Data and Computer Software clause at FAR 242.227-7013, subdivision (b) (3) (ii) or subparagraph (c) (1) (ii), as appropriate. Further use, duplication or disclosure is subject to restrictions applicable to restricted rights software as set forth in FAR 52.227-19 (c) (2).

#### Acknowledgement of Terms and Conditions

YOU ACKNOWLEDGE THAT YOU HAVE READ THIS AGREEMENT, UNDERSTAND IT, AND AGREE TO BE BOUND BY ITS TERMS AND CONDITIONS. NEITHER PARTY SHALL BE BOUND BY ANY STATEMENT OR REPRESENTATION NOT CONTAINED IN THIS AGREEMENT. NO CHANGE IN THIS AGREEMENT IS EFFECTIVE UNLESS WRITTEN AND SIGNED BY PROPERLY AUTHORIZED REPRESENTATIVES OF EACH PARTY. BY USING THIS PRINTER, YOU AGREE TO ACCEPT THE TERMS AND CONDITIONS OF THIS AGREEMENT.

# 5525B/31/32 Line Matrix Printer User's Manual



---

P/N 422721-001

Compaq® makes no representations or warranties of any kind regarding this material, including, but not limited to, implied warranties of merchantability and fitness for a particular purpose. Compaq shall not be held responsible for errors contained herein or any omissions from this material or for any damages, whether direct, indirect, incidental or consequential, in connection with the furnishing, distribution, performance or use of this material. The information in this manual is subject to change without notice.

This document contains proprietary information protected by copyright. No part of this document may be reproduced, copied, translated or incorporated in any other material in any form or by any means, whether manual, graphic, electronic, mechanical or otherwise, without the prior written consent of Compaq.

COPYRIGHT © 1999, COMPAQ COMPUTER CORPORATION

All rights reserved.



# Table of Contents

<b>1</b>	<b>Introduction .....</b>	<b>11</b>
	Printer Overview .....	11
	The Printer Family .....	11
	Conventions in This Manual.....	12
	Warnings and Special Information .....	13
	Related Documents.....	13
	Graphics Enhancements.....	13
	Taking Care of Your Printer .....	14
	Protocols and Emulations .....	14
<b>2</b>	<b>Setting Up the Printer .....</b>	<b>15</b>
	Before You Begin .....	15
	Power Requirements .....	15
	Select a Site .....	16
	Printer Dimensions .....	17
	Printer Component Locations .....	18
	Remove Packing Materials.....	19
	Adjust the Paper Supports .....	22
	Release the Paper Chains (Cabinet Model).....	23
	Remove Tags.....	24
	Attach the Output Basket (Pedestal Model) .....	26
	Connect the Interface and Power Cords .....	27
	Cabinet Model.....	27
	Pedestal Model .....	29
	Interface Connections .....	30
	Install Basic Components .....	31
	Attach the Control Panel Overlays .....	31
	Load the Ribbon.....	32
	Load the Paper.....	34



## Table of Contents

---

Set the Top-of-Form .....	38
Procedure .....	38
<b>3 Operating the Printer.....</b>	<b>41</b>
Powering On the Printer .....	41
Operating Modes .....	41
The Control Panel.....	42
Control Panel Keys .....	43
Operational Procedures.....	47
Reloading Paper .....	47
Unloading Paper .....	55
Replacing the Ribbon.....	57
Canceling a Print Job.....	60
<b>4 The Configuration Menus.....</b>	<b>61</b>
Configuration Overview .....	61
Changing and Saving Parameter Settings.....	62
Default and Custom Configurations .....	62
Navigating the Menus .....	63
Changing Parameters Example .....	64
Saving Your New Configuration .....	66
Main Menu .....	69
CONFIG. CONTROL .....	71
Menu .....	71
ACTIVE EMULATION.....	73
EMULATION.....	74
PCL-II Emulation .....	75
LinePrinter Plus Emulation.....	79
P-Series Emulation .....	83
Proprinter XL Emulation .....	87
Epson FX Emulation .....	90
IGP/PGL Submenu .....	93
IGP/VGL Emulation.....	101
MAINT / MISC .....	112

## Table of Contents

---

Menu .....	112
HOST INTERFACE .....	113
Dataproducts Submenu .....	114
Serial Submenu.....	116
IEEE 1284 Parallel (Bidirectional) Submenu.....	120
Ethernet Submenu .....	121
ETHERNET PARAMETERS .....	122
Menu .....	122
PRINTER CONTROL .....	123
DIAGNOSTICS.....	125
RIBBONMINDER.....	128
<b>5 Interfaces .....</b>	<b>131</b>
Overview.....	131
Dataproducts Long Line Interface .....	132
Dataproducts Long Line Interface Signals .....	133
IEEE 1284 Parallel Interface .....	134
Compatibility Mode.....	134
Nibble Mode .....	134
Byte Mode.....	134
Signals .....	135
Terminating Resistor Configurations.....	138
RS-232 and RS-422 Serial Interfaces .....	140
RS-232 .....	140
RS-422 .....	141
Host System Configuration.....	142
Dataproducts Long Lines Parallel Interface .....	142
TCP/IP LAN Configuration .....	142
Serial Configuration.....	143
Internal Ethernet Adapter Configuration .....	144
Ethernet Configuration Using the Printer Front Panel.....	144
Configuring the Internal Ethernet Adapter for TCP/IP .....	146
Host Software.....	146
Compiling Host Software.....	147



## Table of Contents

---

Computer-aided Configuration with ezsetup or npconfig .....	151
Configuration Through the Network with ARP .....	152
Configuration Through the Network with RARP .....	154
Configuration Through the Network with BOOTP .....	155
Restoring Factory Defaults.....	155
Host Configuration .....	156
Direct Printing Without Spooler .....	156
Printing Via the Spooler .....	158
Custom Interface Scripts.....	159
BSD UNIX .....	160
System V UNIX .....	164
npd Pseudo-device Interface .....	166
Other TCP/IP Methods.....	171
Configuring The Internal Ethernet Adapter For Novell .....	172
Host Software .....	172
Internal Ethernet Adapter .....	173
Host Configuration .....	174
PSEVER Setup (Pre-NetWare 4) .....	175
RPRINTER Setup (Pre-NetWare 4) .....	177
NetWare 4 Options .....	180
Configuring the Internal Ethernet Adapter for Windows ....	183
Print Methods Overview .....	183
TCP/IP Setup .....	184
Configuring TCP/IP .....	186
Host Configuration .....	189
<b>6 Troubleshooting .....</b>	<b>195</b>
Cleaning Requirements .....	195
Exterior Cleaning .....	195
Interior Cleaning.....	196
Diagnosing Problems .....	198
Printing a Hex Dump.....	198
Fault Messages.....	200



## Table of Contents

---

<b>A</b>	<b>Printer Specifications .....</b>	<b>207</b>
	Ribbon Specifications .....	207
	Paper Specifications .....	208
	Printer Dimensions .....	209
	Environmental Characteristics .....	210
	Electrical Characteristics .....	211
	Interfaces .....	212
	Printing Rates .....	212
<b>B</b>	<b>Downloading Firmware.....</b>	<b>213</b>
	Loading Flash Memory .....	213
<b>C</b>	<b>ASCII Character Set.....</b>	<b>219</b>
<b>D</b>	<b>Communication and</b>	
	<b>Trademark Information .....</b>	<b>221</b>
	Communication Notices.....	221
	Trademark Acknowledgments .....	223



---

## Table of Contents

---

# 1

## *Introduction*

---

### **Printer Overview**

This chapter provides a general overview of your printer and the conventions used within this manual.

---

#### **The Printer Family**

The Compaq series of line matrix printers consist of 500, 1000, and 1500 lines per minute (lpm) models packaged in various configurations. All of the models offer software versatility and the latest refinements in line matrix printing technology. The print mechanisms are housed in sound-insulated cabinets which make the printer family among the quietest printers in the world.

Most line matrix printers have specialized architectures, which enable the printer to emulate, or behave like, another printer. These specialized architectures are restricted. Your printer, however, has a flexible architecture that allows new features and emulations to be added as they become available.

PCL<sup>®</sup>-II is the standard emulation. LinePrinter Plus<sup>®</sup> is also included with each printer. LinePrinter Plus includes the Epson<sup>®</sup> FX-1050, Printronix<sup>®</sup> P-Series, and IBM<sup>®</sup> Proprinter<sup>®</sup> III XL emulations. The IGP<sup>®</sup>/PGL<sup>®</sup> and IGP/VGL graphics enhancement emulations are available as optional upgrades. No matter what emulation is installed, your printer is easy to use. The message display and lights on the control panel communicate with you directly and clearly. You can select every function on your printer at the control panel, or you can send commands from the host computer.

## Chapter 1 Printer Overview

---

The printer combines the use of Flash, RAM, and nonvolatile RAM for program execution. The Flash is used for all program, font, and emulation storage. New fonts, emulations, or program updates can be downloaded to Flash memory via the parallel or serial interface. The RAM is used for buffers, print image storage, and execution variables. The non-volatile RAM stores configuration, statistics, and internal parameters.

Refer to the following table for a complete listing of model numbers and options.

**Table 1. The Compaq Line Matrix Printer Family**

Model Number	Print Speed	Pedestal	Cabinet
5525B	500 lpm	✓	
5531	1000 lpm		✓
5532	1500 lpm		✓

### Conventions in This Manual

---

All uppercase print indicates control panel keys.

**Example:** Press the CLEAR key, then press the ON LINE key.

Quotation marks (“ ”) indicate messages on the Liquid Crystal Display (LCD).

**Example:** Press the ON LINE key. “OFFLINE” appears on the LCD.

The + (plus) symbol represents key combinations.

**Example:** “Press ▲ + ▼” means press the ▲ (UP) key and the ▼ (DOWN) key at the same time.

## Warnings and Special Information

---

Read and comply with all information highlighted under special headings:

- WARNING**    **Conditions that can harm you as well as damage the printer.**
- CAUTION**    **Conditions that can damage the printer or related equipment.**
- IMPORTANT**    **Information that is vital to the operation of the printer.**
- NOTE:** Information affecting printer operation.

## Related Documents

---

- *Maintenance Manual* — Explains how to maintain and repair the line matrix printer at the field service level of maintenance.
- *LinePrinter Plus Programmer's Reference Manual* — Covers the host control codes for the LinePrinter Plus emulations.
- *PCL-II Programmer's Reference Manual* — Covers the host control codes for the Printer Control Language emulation.
- *IGP/PGL Programmer's Reference Manual* — Provides information used with the optional IGP Printronix emulation enhancement feature.
- *IGP/VGL Programmer's Reference Manual* — Provides information used with the optional Code V™ emulation enhancement feature.
- *PrintNet™ User's Manual* — Information about network protocols, configuration, and operation.

## Graphics Enhancements

---

The IGP/PGL and IGP/VGL emulations allow you to create and store forms, generate logos, bar codes, expanded characters, and create other graphics. Alphanumeric and bar code data are added as the form is printed. These emulations are available as factory-installed or field-installed options. For more information, contact your authorized service representative.

## Taking Care of Your Printer

---

Your printer will produce high print quality jobs if it is well taken care of. Periodic cleaning, handling the printer properly, and using the correct printer supplies such as paper and ribbons ensures optimum performance. Chapter 6 explains how to clean the printer, and printer supplies are listed in Appendix A.

Whenever it is necessary to service the printer, remember these important maintenance concepts:

- Use only the ribbons specified in Appendix A. Use of incorrect ribbons can lead to ink migration problems, degraded print quality, and expensive damage to the printer.
- Incorrect closure of the forms thickness lever can lead to smearing, degraded print quality, paper jams, and damage to the platen and shuttle assembly. Never close the forms thickness lever too tightly.

## Protocols and Emulations

---

A *protocol* is a set of rules governing the exchange of information between the printer and its host computer. These rules consist of codes that manipulate and print data and allow for machine-to-machine communication. A printer and its host computer must use the same protocol. As used in this manual, protocol and emulation mean the same thing.

Most impact printers use single ASCII character codes to print text, numbers, and punctuation marks. Some characters, both singly and in groups of two or more, are defined as control codes. Control codes instruct the printer to perform specific functions, such as underlining text, printing subscripts, setting page margins, etc. The main difference between most printer protocols is in the characters used to create control codes and the ways in which these characters are formatted.

When the printer executes the character and control codes of a particular printer protocol, it is “emulating” that printer. If the printer uses the Proprinter XL protocol, for example, it is emulating a Proprinter XL printer. If the printer is using the Epson FX printer protocol, for example, we can also say it is in Epson FX emulation mode.

---

# 2

## *Setting Up the Printer*

---

### **Before You Begin**

Read this chapter carefully before installing and operating the printer. The printer is easy to install. However, for your safety, and to protect valuable equipment, perform all the procedures in this chapter in the order presented.

---

### **Power Requirements**

The printer must be connected to a power outlet that supplies 88 to 135 Volts AC or 178 to 270 Volts AC at 47 to 63 Hz. The printer automatically senses and adjusts itself to conform to the correct voltage range.

Primary circuit protection is provided by the power switch, which is also a circuit breaker. Consult an electrician if printer operation affects local electrical lines. See "Printer Specifications" on [page 207](#) for additional power specifications.

#### **IMPORTANT**

**It is recommended that printer power be supplied from a separate AC circuit protected at 10 amperes for 120 volts or 5 amperes for 230 volts at 50 or 60 Hertz.**

## Select a Site

---

Select a printer site that meets all of the following requirements:

- Permits complete opening of the printer cover and doors.
- For cabinet models, allows at least three feet of clearance behind the printer. (This permits air to circulate freely around the printer and provides access to the paper stacking area.)
- Has a standard power outlet that supplies 88-135 Volts AC or 178-270 Volts AC power, at 47 to 63 Hz.
- Is relatively dust-free.
- Has a temperature range of 10° C to 40° C (50° F to 104° F), and a relative humidity from 15% to 90% non-condensing.
- Is located within the maximum allowable cable length to the host computer. This distance depends on the type of interface you plan to use, as shown in [Table 2](#).

**Table 2. Maximum Interface Connection Cable Length**

Interface Type	Maximum Cable Length
Dataproducs Parallel	12 meters (40 feet)
IEEE 1284 Parallel	10 meters (32 feet)
Serial RS-232	15 meters (50 feet)
Serial RS-422	1220 meters (4000 feet)
Dataproducs Long Line	150 meters (492 feet)
Ethernet 10Base-T	100 meters (328 feet)
Ethernet 10Base2	185 meters (607 feet)



---

## Printer Dimensions

---

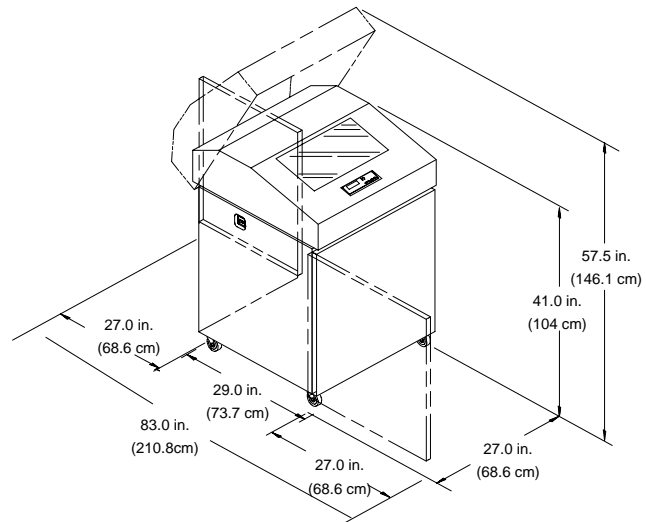

**Figure 1. Printer Dimensions (Cabinet Model)**

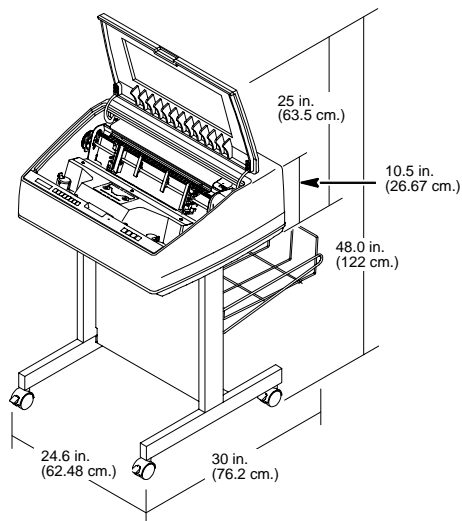

**Figure 2. Printer Dimensions (Pedestal Model)**

## Printer Component Locations

Familiarize yourself with the names and locations of the printer components, shown in [Figure 3](#), before continuing with the rest of the installation procedure.

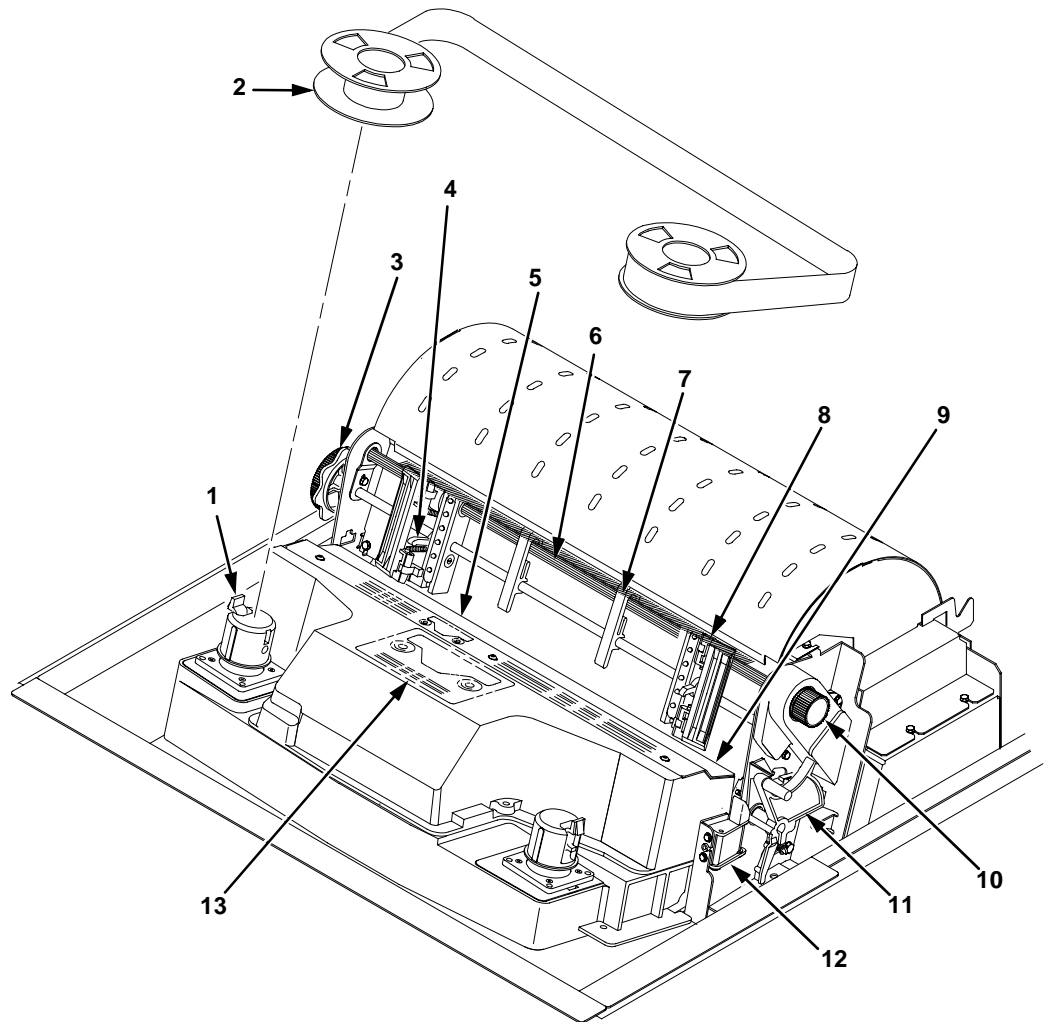

Figure 3. Printer Component Locations

---

**Legend:**

- 1) Hub Latch
- 2) Ribbon Spool
- 3) Horizontal Adjustment Knob
- 4) Tractor Lock
- 5) Paper Scale
- 6) Splined Shaft
- 7) Paper Support
- 8) Tractor
- 9) Hammer Bank Cover and Ribbon Mask
- 10) Vertical Position Knob
- 11) Forms Thickness Lever
- 12) Ribbon Guide
- 13) Ribbon Loading Path Diagram

## **Remove Packing Materials**

---

**CAUTION** To avoid shipping damage, reinstall the shipping restraints whenever you move or ship the printer.

Save the cardboard packing, foam blocks, and bubble wrap along with the other packing materials in case you need to move the printer. If it is necessary to move the printer, reinstall the shipping restraints, reversing the steps in this section.

## Chapter 2 Remove Packing Materials

---

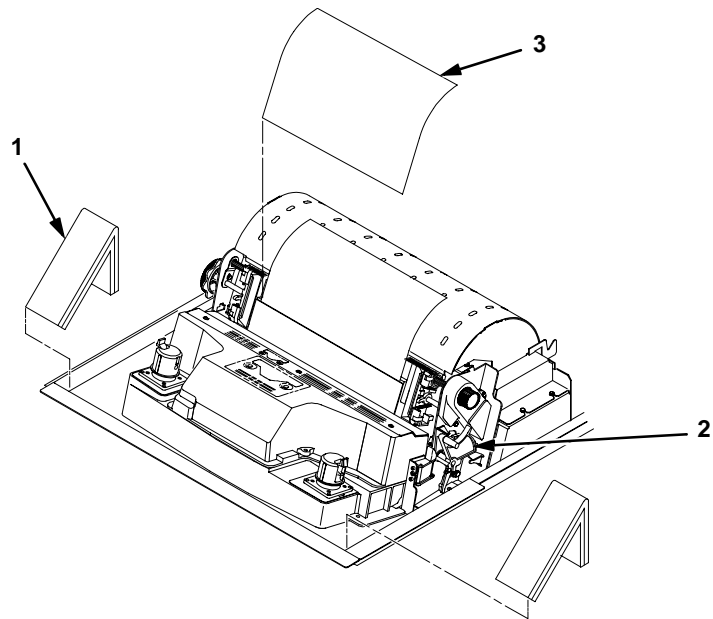

1. Raise the printer cover.
2. Remove the cardboard packing (1).
3. Open the tractor doors. Push the tractor locks down. Slide the tractors outward as far as they will go. The forms thickness lever (2) should be in the fully open (raised) position.
4. Remove the envelope (3) containing the sample configuration printout. Store the envelope in the pouch attached to the left interior side of the cabinet.

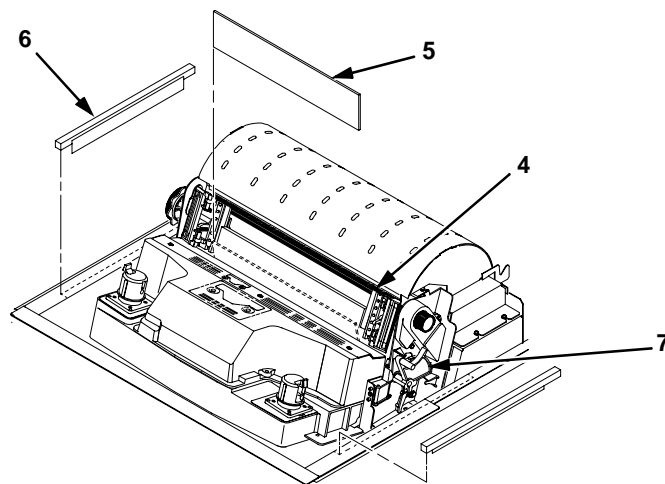

5. Slide the paper supports (4) outward as far as they will go. Lift the hammer bank protective foam (5) and remove it from between the ribbon mask and the platen.
6. Remove the foam strips (6) and the tape securing the foam strips.
7. Rotate the forms thickness lever (7) downward to position "A".

## Chapter 2 Remove Packing Materials

---

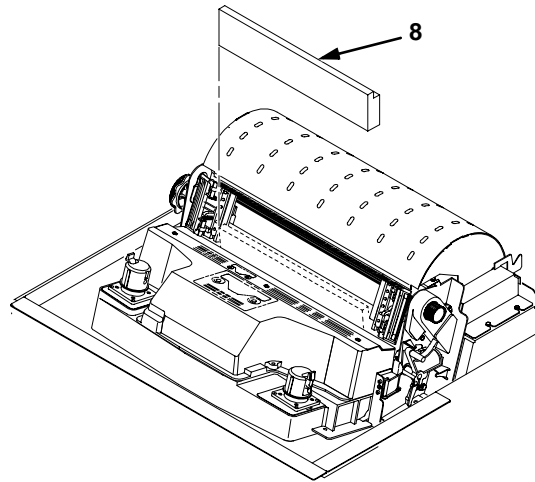

8. Rotate the platen protective foam (8) toward the front of the printer and out from under the support shaft.

### Adjust the Paper Supports

---

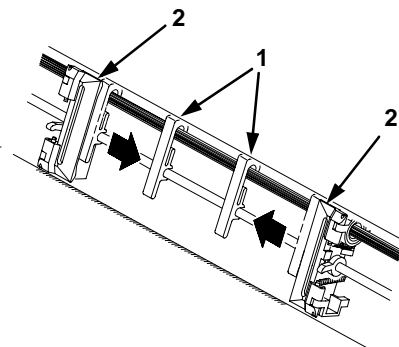

1. Slide the paper supports (1) inward until they are approximately four inches from the tractor doors (2).

## Release the Paper Chains (Cabinet Model)

---

### Release the Paper Chains (Cabinet Model)

---

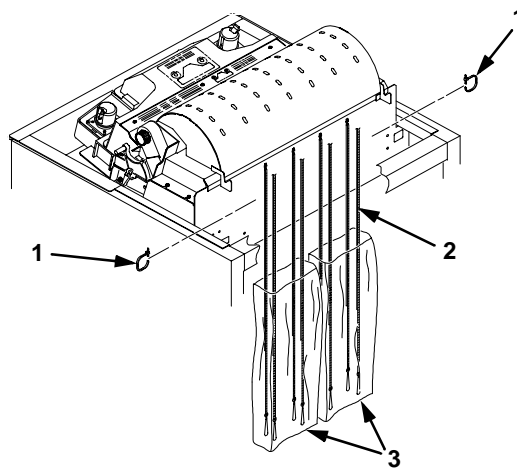

1. Open the cabinet rear door.
2. Cut the tie wraps (1) and release the paper chains (2) from the bags (3) at the top rear of the printer frame. Remove the tie wraps and bags.
3. Make sure each chain hangs freely, with no kinks or knots.

## Remove Tags

### Cabinet Model

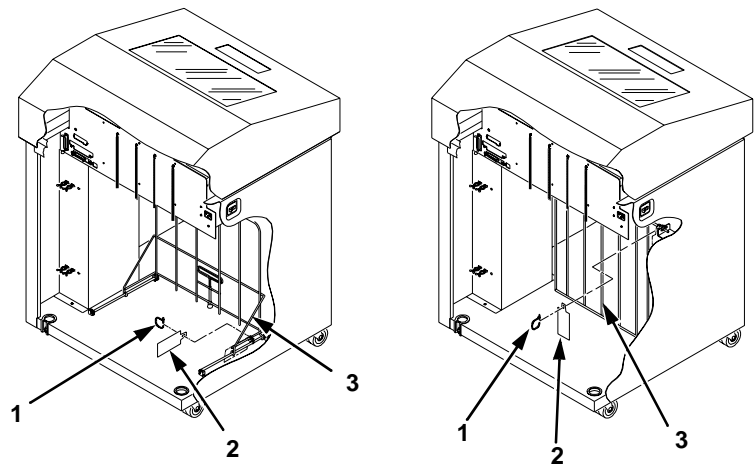

**Figure 4. Removing Tags**  
(Left: 1000/1500 lpm models; Right: 500 lpm models)

1. Remove the tie wrap (1) attached to the passive stacker paper fence (3). It is marked with a large, red tag (2).
2. Close the cabinet rear door.



## Remove Tags

---

### Pedestal Model

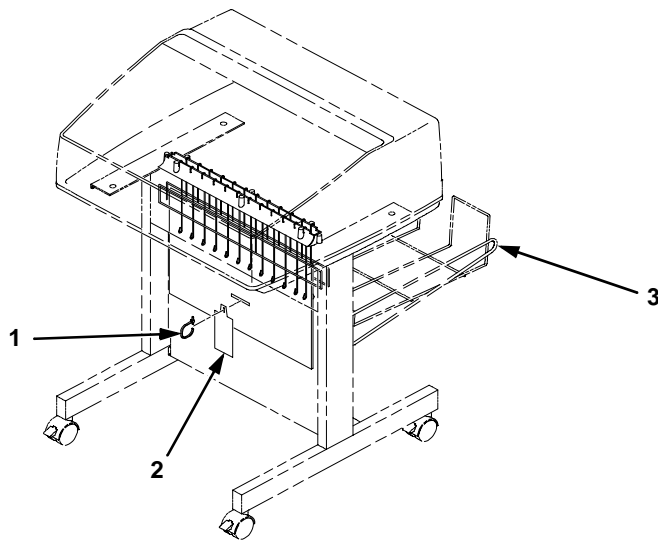

Remove the tie wrap (1) attached to the output basket (3). It is marked with a large, red tag (2).

### Attach the Output Basket (Pedestal Model)

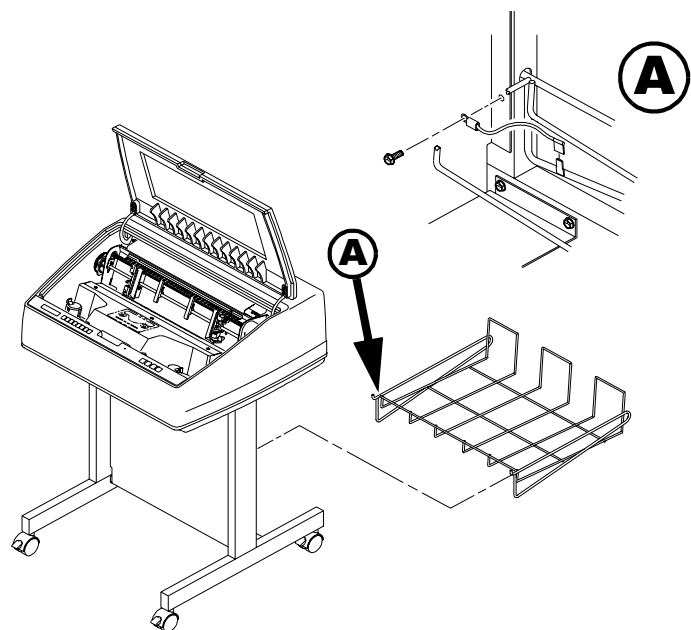

1. Place the output basket in the holes in the back of the printer.
2. Screw the ground wire attached to the output basket to the printer.

---

## Connect the Interface and Power Cords

---

Before you connect the interface and power cables, verify the voltage source at the printer site conforms to the requirements specified in “Power Requirements” on [page 15](#).

### Cabinet Model

---

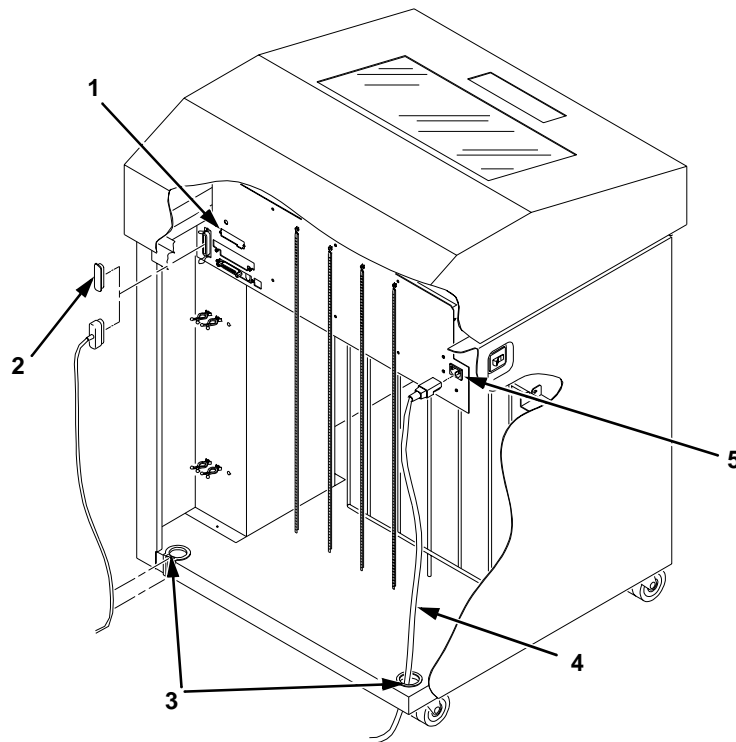

**Legend:**

- 1) Host Interface Connectors
- 2) I/O Cover
- 3) Cable-Routing Notches
- 4) AC Power Cable
- 5) AC Power Connection

**Figure 5. Interface and Power Locations**

## Chapter 2 Connect the Interface and Power Cords

1. Make sure the printer power switch is set to O (Off).
2. Open the cabinet rear door, and remove the cover from the selected I/O connector. (See “Interface Connections” on [page 30](#).)
3. Locate the cable routing notch in the lower left corner of the back of the cabinet (see [Figure 5](#)).

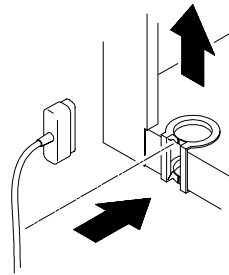

4. Hold the I/O cable below its connector and gently push the cable through the opening in the grommet seated in the notch.
5. Pull the cable up through the notch until it reaches the I/O plate. Attach the cable connector to the printer interface connector previously selected in step 2 of this section. Secure the cable to the printer using the upper and lower standoffs.

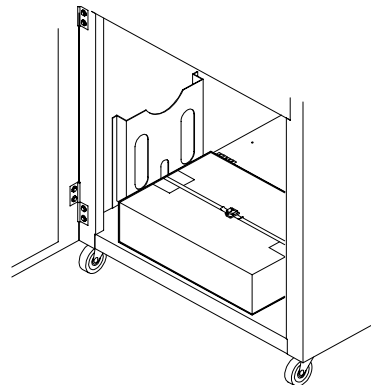

6. Open the cabinet front door and cut the strap that secures the box, which contains the power cord, printer ribbon, control panel overlay labels, and documentation.
7. Open the box and remove the power cord, overlays, and documentation.

## Pedestal Model

---

8. Guide the power cord up through the hole in the lower right back corner of the cabinet (see [Figure 5](#)). Thread the power cord inside the bracket where the gas spring is attached.
9. Plug the power cord into the printer AC power connector, then into the AC power outlet.

## Pedestal Model

---

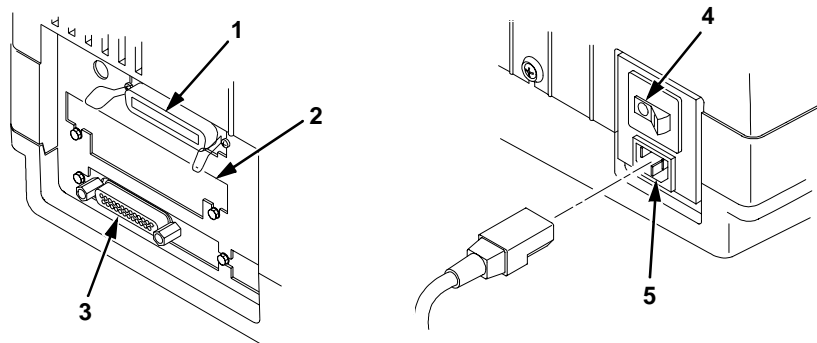

### Legend:

- 1) Parallel Connector
- 2) Auxiliary I/O
- 3) Serial Connector
- 4) Power Switch
- 5) AC Power Connector

1. Make sure the printer power switch is set to O (OFF).
  2. Remove the cover from the I/O connector you have selected. (See below.)
  3. Attach the cable connector to the printer interface connector.
- Plug the power cord into the printer AC power connector, then into the AC power outlet.

## Interface Connections

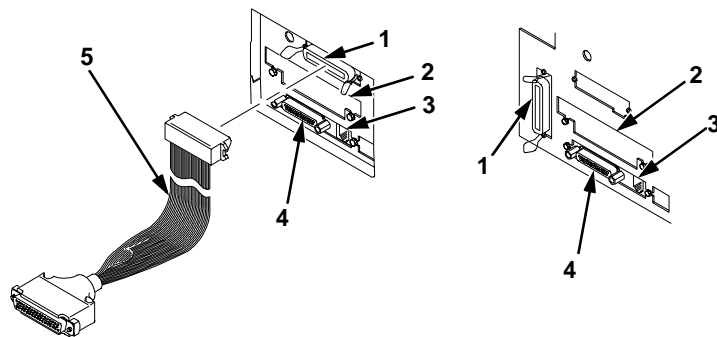

**Legend:**

- 1) Parallel (not present on Network-based models)
- 2) Auxiliary I/O
- 3) Diagnostic
- 4) Serial RS-232/RS-422
- 5) Dataproducts Standard Adapter

**Figure 6. Standard Interfaces  
(Left: Pedestal Model; Right: Cabinet Model)**

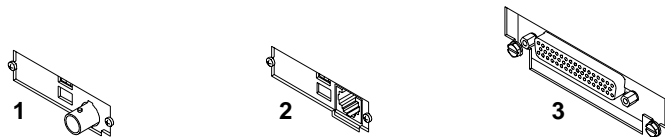

**Legend:**

- 1) Network 10Base2
- 2) Network 10Base-T
- 3) Dataproducts Long Line

**Figure 7. Optional Interfaces for the Auxiliary I/O**

1. Remove the cover from the I/O connector you have selected.
2. Attach the I/O cable connector to the printer interface connector.

## Attach the Control Panel Overlays

---

### Install Basic Components

---

The following procedures describe how to attach the printed overlays to the control panel and install the printer ribbon and paper.

#### Attach the Control Panel Overlays

---

1. Choose the overlay labels in the appropriate language.
2. Cabinet Models: Open the printer cover, peel off the protective backing, and press the overlay into place.
3. Pedestal Models: Open the printer cover and insert overlay labels by sliding them behind the control panel assembly in the appropriate place.

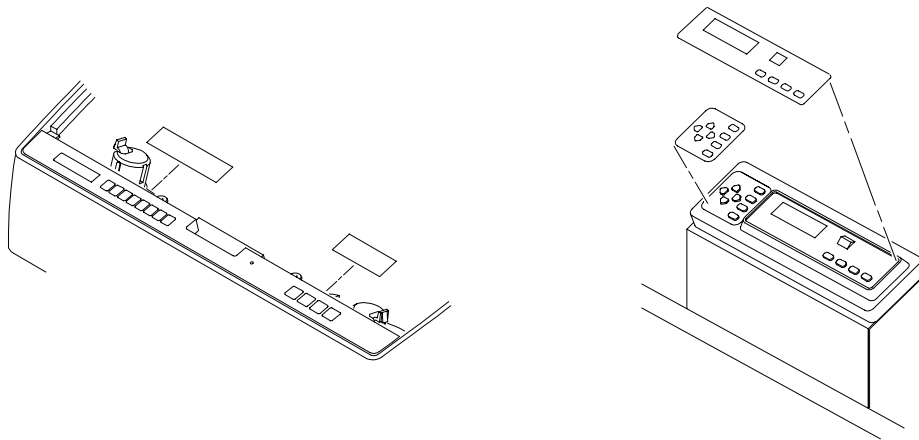

**Figure 8. Attaching Control Panel Overlays  
(Left: Pedestal Models; Right: Cabinet Models)**

## Load the Ribbon

1. Refer to the ribbon path diagram molded onto the shuttle cover (see “Printer Component Locations” on [page 18](#)).
2. Open the printer cover.

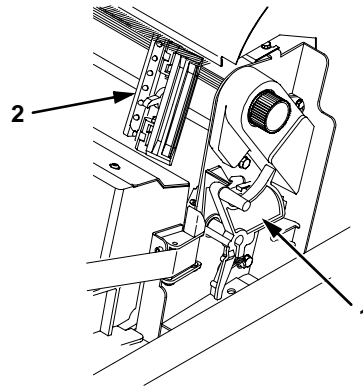

3. Raise the forms thickness lever (1) as far as it will go.
4. Open the tractor doors (2).

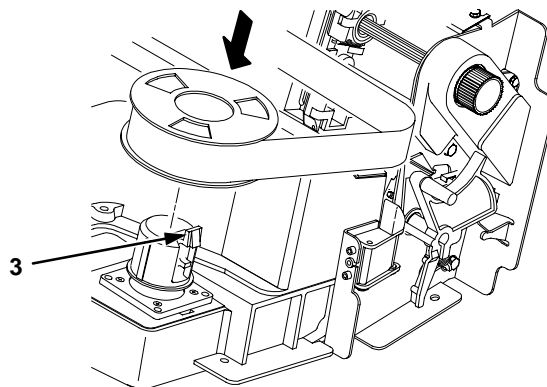

5. Squeeze the right hub latch (3) and place the full spool on the right hub. Be sure the ribbon feeds off the outside of the spool. Press the spool down until the hub latch snaps into place.



## Load the Ribbon

---

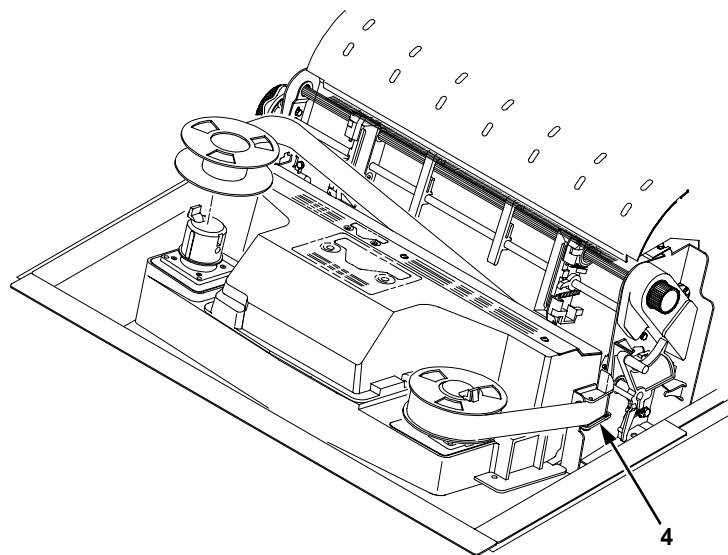

6. Thread the ribbon around the ribbon guide (4) and along the ribbon path. Be sure to thread the ribbon between the hammer bank cover and the ribbon mask.
7. Place the empty spool on the left hub. Press the spool down until the hub latch snaps into place. Turn the empty spool by hand to make sure the ribbon tracks correctly in the ribbon path and ribbon guides.

## Load the Paper

When you start this procedure, verify that the printer cover is open, the forms thickness lever is raised, and the tractor doors are open. (See “Printer Component Locations” on [page 18](#)).

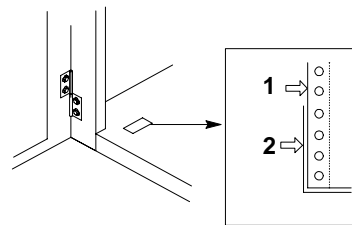

**Legend:**

- 1) Edge Of Paper
- 2) Box

1. For cabinet models, align the paper supply with the label on the floor. Make sure that the paper pulls freely from the box.

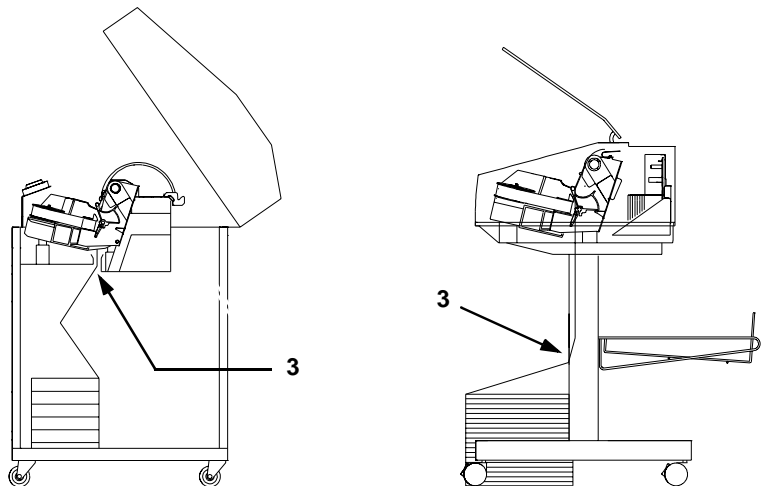

2. Feed the paper up through the paper slot (3). Hold the paper in place with one hand (to prevent it from slipping down through the paper slot) while pulling it through from above with your other hand.

## Load the Paper

---

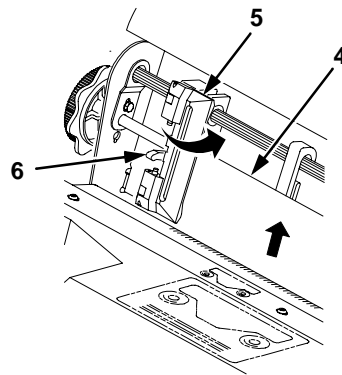

3. Pull the paper (4) above and behind the ribbon mask, which is a silver metal strip with a clear plastic edge protector. Load the paper on the left tractor sprockets and close the tractor door (5).

**CAUTION** To avoid damage to the printer caused by printing on the platen, always position the left tractor unit directly to the left of the “1” mark on the paper scale.

4. If adjustment is necessary, unlock (6) the left tractor. Slide the tractor until it is directly to the left of the number “1” on the paper scale (10) and lock it. You can also use the paper scale to count columns.

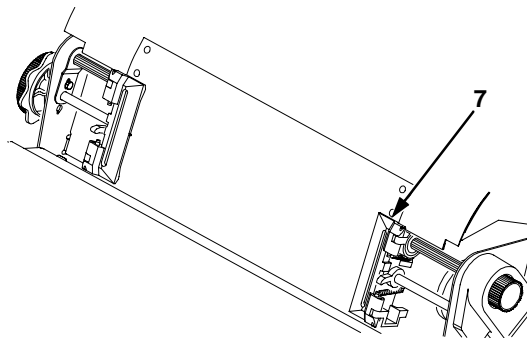

5. Unlock the right tractor (7). Load the paper onto the right tractor sprockets and close the tractor door.

## Chapter 2 Install Basic Components

---

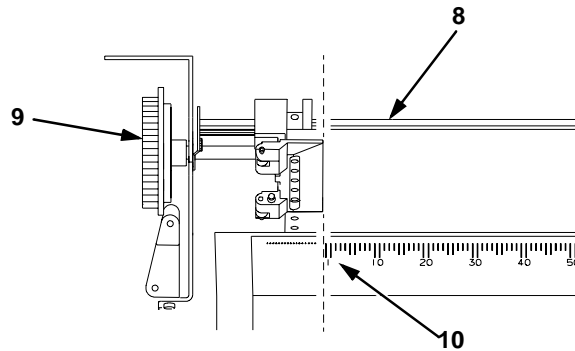

6. Make sure the leading edge of the first sheet of paper is parallel to the tractor splined shaft (8). If the paper is misaligned, reload it onto the tractor sprockets until its edge is parallel to the splined shaft.
7. Slide the right tractor to remove paper slack or to adjust for various paper widths. Lock the tractor.
8. After both tractors are secured, you may use the horizontal adjustment knob (9) to make fine horizontal paper adjustments.

## Load the Paper

---

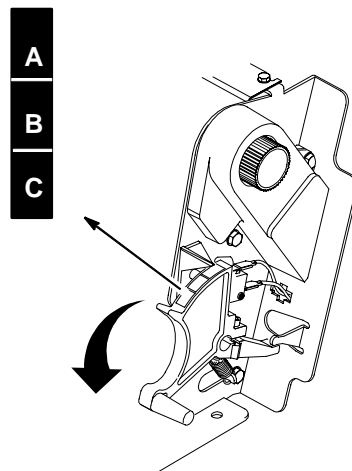

9. Lower the forms thickness lever. Set it to match the paper thickness.  
(The A-B-C scale corresponds approximately to 1-, 3-, and 6-part paper thickness.)

**NOTE:** Do not set the forms thickness lever too tightly; excessive friction can cause paper jams, ribbon jams with potential for ribbon damage, smeared ink, or wavy print.

## Set the Top-of-Form

---

When paper is loaded into the printer, it must be told where you want the top of your form to be. This procedure must be performed the first time paper is introduced into the printer, as well as every time new paper is loaded.

### Procedure

---

1. Be sure the forms thickness lever is lowered. If the printer is off, set the power switch to I (On).
2. Press ON LINE to place the printer in offline mode. The LCD will then display "OFFLINE / CONFIG. CONTROL."
3. Press FF several times to ensure the paper feeds properly beyond the tractors and over the lower paper path. Ensure the paper folds properly in the stacking area.

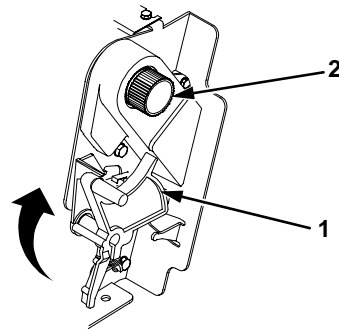

4. Raise the forms thickness lever (1) as far as it will go. This allows you to turn the vertical position knob (2) freely in order to align the top-of-form.

## Procedure

---

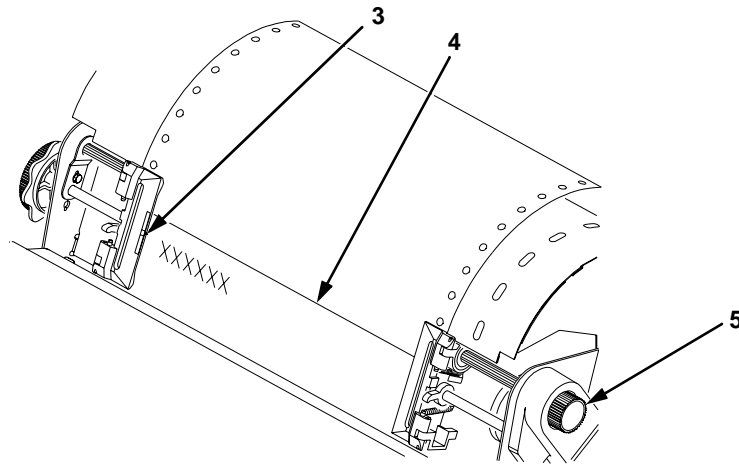

5. Locate the TOF indicator (3). It is the small tab located on both the right and left tractor door.
6. Turn the vertical position knob (5) to align the top of the first print line with the TOF indicator. For best print quality, it is recommended the top-of-form be set at least 1/2 inch below the perforation (4).

## Chapter 2 Set the Top-of-Form

---

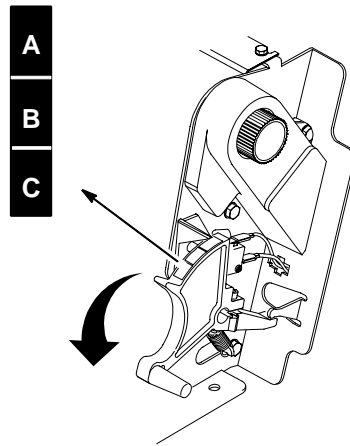

7. Lower the forms thickness lever. Set it to match the paper thickness. (The A-B-C scale corresponds approximately to 1-, 3-, and 6-part paper thickness.)

**NOTE:** Do not set the forms thickness lever too tightly; excessive friction can cause paper jams, ribbon jams with potential for ribbon damage, smeared ink, or wavy print.

8. Press SET TOF. The top-of-form position you have set moves down to the print position.
9. Press CLEAR to remove any fault messages (such as "LOAD PAPER") from the message display.
10. Press ON LINE to place the printer in online mode.



---

# 3

## *Operating the Printer*

---

### Powering On the Printer

When you power on the printer, it executes a self-test. The default power-up state is online. When the self-test completes and the software has initialized successfully, the status indicator light turns on, indicating the printer is online. The default value of the type of emulation you have installed appears in the display.

If there is a fault during the self-test, the status indicator flashes and a specific fault message appears on the display (such as “LOAD PAPER”). The alarm also sounds if it is configured to do so. See “Troubleshooting” on [page 195](#) for information on fault messages and solutions.

---

### Operating Modes

**Online.** In online mode, the printer can receive and print data sent from the host. Pressing the ON LINE key toggles the printer from offline to online mode. The status indicator is lit in online mode.

**Offline.** In offline mode, you may perform operator functions, such as loading paper and setting top-of-form. You may also move within the printer configuration menus. Pressing the ON LINE key toggles the printer from online to offline mode. The status indicator is off in offline mode.

**Fault.** In fault mode, a fault condition exists which must be cleared before printing can continue. The status indicator flashes, the alarm beeps (if configured to sound), and a descriptive fault message displays.

## Chapter 3 The Control Panel

The current operating mode may be selected via control panel keys, or may result from routine operations such as powering on the printer.

### The Control Panel

Figure 9 and Figure 10 show the keys, displays and indicators as they appear on the control panel. The following section provides descriptions of each of the control panel keys and their functions.

Key combinations are indicated with the plus (+) sign. For example, “Press ▲ + ▼” means to press the ▲ key and the ▼ key at the same time.

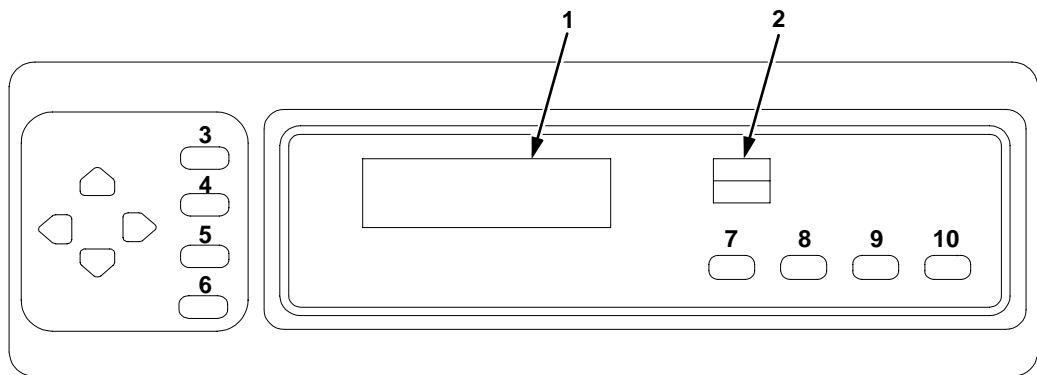

Figure 9. Control Panel, Cabinet Model

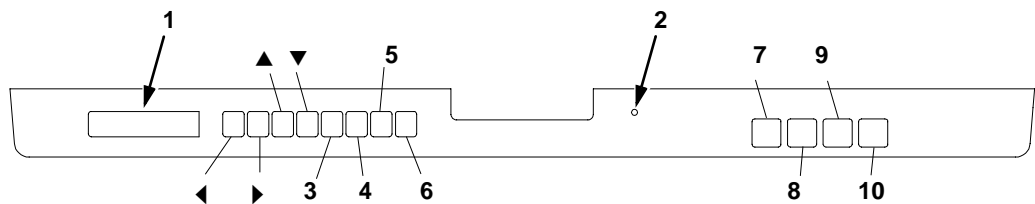

Figure 10. Control Panel, Pedestal Model

**Legend:**

- 1) Message Display
- 2) Status Indicator
- 3) CLEAR
- 4) SHIFT
- 5) SET TOF / L.P.I. ADJ.
- 6) ENTER / PAGE L. ADJ.
- 7) ON LINE
- 8) FF
- 9) LF
- 10) VIEW

## Control Panel Keys

---

### **ON LINE**

Toggles the printer between online and offline modes. If a fault condition exists, pressing this key will clear the fault message and return the printer from fault mode to offline mode.

**NOTE:** If the fault condition is not corrected *before* pressing this key, the fault message will reappear when attempting to place the printer online.

### **FF (Form Feed)**

Causes the paper to advance to the top-of-form on the next page.

In online or offline mode, press and release to advance the paper to top-of-form on the next page. If there is data in the printer buffers, the data will print and then the paper will move to the next top-of-form.

In the fault state, FF does not advance the paper to the next top-of-form; instead, it will slew the paper 11 inches.

### **LF (Line Feed)**

Advances the paper one line at a time. Unprinted data in the print buffer will print before the paper moves.

With the printer offline, press and release to advance the paper one line at a time. If there is data in the printer buffer, the data will print before the line feed occurs. Press and hold to repeat forward paper movement.

LF does not operate in the fault or online states.

## Chapter 3 The Control Panel

---

### VIEW

In offline or online mode, allows you to view and adjust the placement of data on the page, or to remove peel-off labels.

With the printer online or offline, press and release to move paper forward for inspection. The last data printed advances to the tractor area. Press VIEW a second time to move the paper back to its previous print position.

If the printer is online and printing, press VIEW to stop printing. The paper advances. Press ▲ or ▼ to move 1/72" vertically for fine vertical forms alignment. Press VIEW. The paper moves back and printing resumes.

Pressing ON LINE also moves the paper back to its original print position and returns the printer to online.

### CLEAR

Clears a fault message and returns the printer from fault mode to offline mode.

After correcting the fault, press and release. The fault message is cleared, and the printer returns to offline mode.

Other functions:

- Moves to the top of the configuration menu when the printer is in the configuration menus.
- Cancels data in the buffer. Place the printer offline. From the host system, stop the print job. Press CLEAR+ENTER. Reset the top-of-form ([page 38](#)).
- Press SHIFT+CLEAR to reset the PCL-II emulation.

### SHIFT

The printer must be offline to perform the following functions:

- Press SHIFT+CLEAR to reset the PCL-II emulation.
- Press SHIFT+L.P.I. Adj to access the line spacing menu. Press PREV or NEXT to scroll through the options.
- Press SHIFT+Page L. Adj to access the form length menu in lines or inches. The page length is selected by lines/page or inches/page, depending on which option is chosen in the PCL-II submenu.
- Press SHIFT+▲ to micro step the paper upward in 1/72 inch increments.
- Press SHIFT+▼ to micro step the paper downward in 1/72 inch increments.

### SET TOF

Sets the top-of-form on the printer. This key is active only when the printer is offline and will not operate if the printer is in a fault condition. The paper moves down to the print position and aligns to the top-of-form. See [page 38](#) for the complete top-of-form setting procedure.

**NOTE:** If there is any data in the buffer, the paper will move to the last print position.

### ENTER

When navigating the configuration menus, ENTER selects the currently displayed option value as the active value. An asterisk (\*) appears next to the active value on the display. ENTER is also used for starting and stopping printer tests and generating a configuration printout.

**NOTE:** The ENTER key must be unlocked in order to function. See UP + DOWN, below.

## Chapter 3 The Control Panel

---

### **UP or DOWN ( ▲ or ▼ )**

Moves up and down between levels in the configuration menus and makes vertical forms adjustment. After pressing VIEW, press ▲ or ▼ to adjust the paper up or down in 1/72 inch increments for fine vertical forms alignment. After pressing ON LINE, press ▲ or ▼ to move through levels in the configuration menus.

### **UP + DOWN ( ▲ + ▼ )**

Locks and unlocks the ENTER key.

### **PREV or NEXT ( ◀ or ▶ )**

Moves between the options on the current level of configuration menu. In the configuration menu press ◀ to scroll backward or press ▶ to scroll forward through the menu selections on the same level.

### **PREV + NEXT ( ◀ + ▶ )**

When both keys are pressed simultaneously, the printer performs a soft reset of the LP+ emulation and the printer buffers are cleared.

---

## Operational Procedures

---

This section outlines certain basic procedures which need to be performed when necessary in order to keep your printer operating.

### Reloading Paper

---

Follow this procedure when “LOAD PAPER” displays. (This message occurs when the last sheet of paper passes through the paper slot.) This procedure reloads paper without removing the last sheet of the old paper supply. This action retains the current top of form setting.

1. Raise the printer cover. Raise the forms thickness lever as far as it will go. (See Figure 3 on [page 18](#) for the location of the lever.)
2. Press CLEAR to turn off the alarm. Do not open the tractor doors or remove the existing paper.
3. For cabinet models, open the front door. Align the paper supply with the label on the floor. Ensure the paper pulls freely from the box.

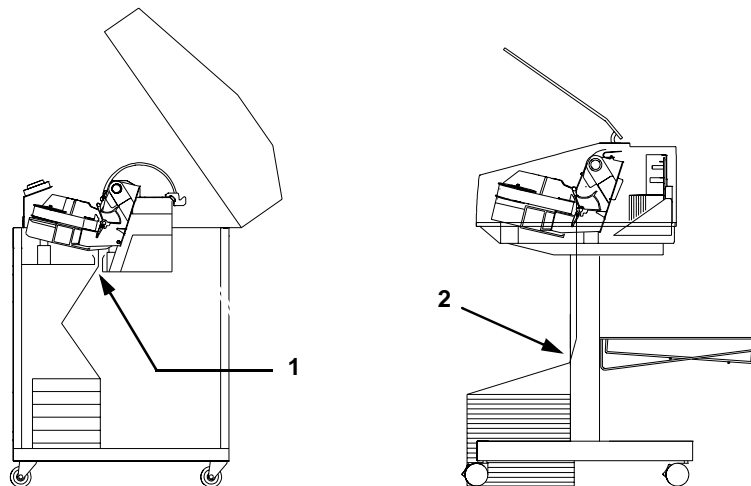

**Legend:**

- 1) Paper Slot (Cabinet Model)
- 2) Paper Slot (Pedestal Model; 8" below printer base)

**Figure 11. Paper Slot Location**

## Chapter 3 Operational Procedures

4. Locate the paper slot and feed the paper up through it (see [Figure 11](#)). It may be easier to feed one corner of the new paper up through the slot first. When this corner can be grasped from the top, rotate the paper back to the normal position.

**NOTE:** If you are using thick, multi-part forms and are unable to load the new paper over the existing paper, go to step [14](#).

5. Hold the paper to prevent it from slipping down and through the paper slot.

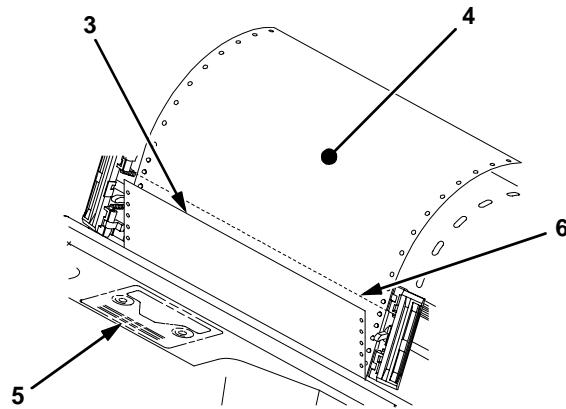

6. Pull the new paper (3) above and behind the ribbon mask, but in front of the existing paper (4). The ribbon mask location is shown on the ribbon path diagram (5). If necessary, gently press the existing paper back.
7. Align the top edge of the new paper with the top perforation of the existing paper (6).
8. Load the new paper over the existing paper. Open and load the tractors one at a time to prevent the paper from slipping.

**NOTE:** Make sure that the top edge of the new paper lines up with the top horizontal perforation of the last page.



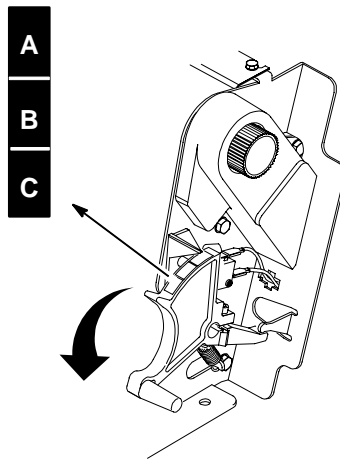

9. Lower the forms thickness lever. Set it to match the paper thickness.  
(The A-B-C scale corresponds approximately to 1-, 3-, and 6-part paper thickness.)

**NOTE:** Do not set the forms thickness lever too tightly; excessive friction can cause paper jams, ribbon jams with potential for ribbon damage, smeared ink, or wavy print.

10. Press CLEAR to remove the "LOAD PAPER" fault message from the display.
11. Press FF several times to make sure the paper feeds properly beyond the tractors and over the lower paper guide. Feed sufficient paper to ensure the paper stacks correctly.
12. Close the printer cover. Close the cabinet front door.
13. Press ON LINE to place the printer in online mode and resume printing.

## Chapter 3 Operational Procedures

---

Perform steps 14 through 30 only if you are unable to load the new paper over the existing paper in step 4.

14. Open both tractor doors.
15. Remove the paper from the tractors. Allow the paper to fall into the paper supply area.

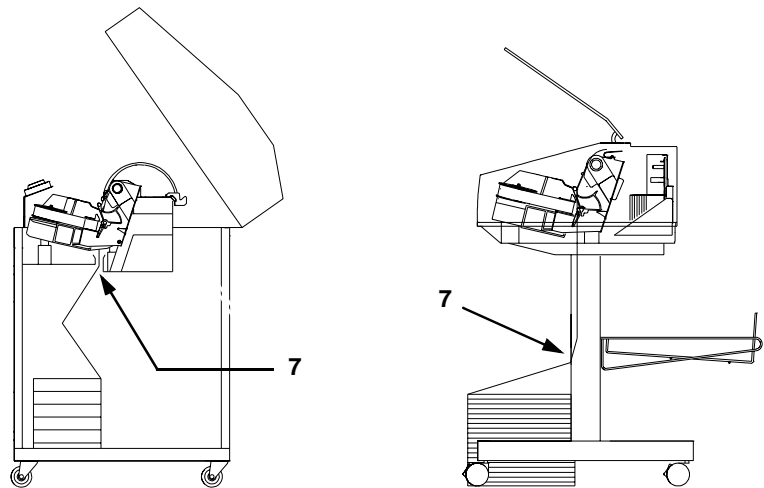

16. Feed the paper up through the paper slot (7). Hold the paper to prevent it from slipping down through the paper slot.

## Reloading Paper

---

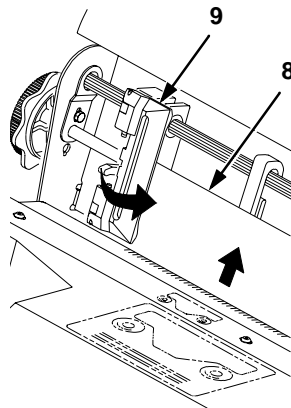

17. Pull the paper (8) above and behind the ribbon mask. (The ribbon mask location is shown on the ribbon path diagram.)
18. Load the paper on the left tractor and close the tractor door (9).

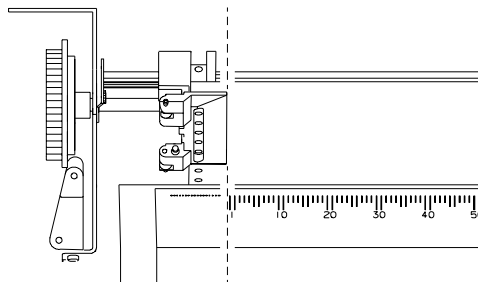

**CAUTION** To avoid damage to the printer caused by printing on the platen, always position the left tractor unit directly to the left of the “1” mark on the paper scale.

19. Normally, you should not need to adjust the position of the left tractor. If adjustment is necessary, unlock the left tractor. Slide the tractor until it is directly to the left of the number “1” on the paper scale and lock it. (You can also use the paper scale to count columns.)

## Chapter 3 Operational Procedures

---

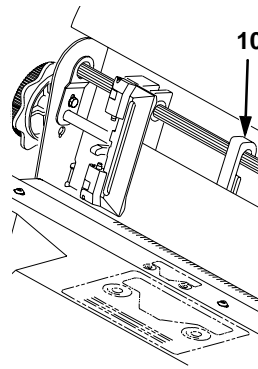

20. Move the paper supports (**10**) as necessary to support the paper between the tractors.

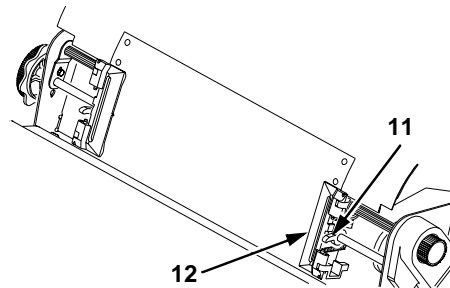

21. Unlock the right tractor (**11**). Load the paper onto the sprockets and close the tractor door (**12**). If necessary, slide the right tractor to remove paper slack or to adjust for various paper widths. Then, lock the tractor.

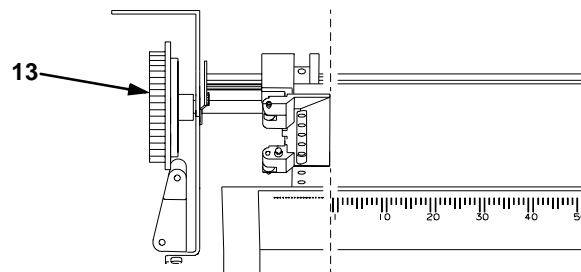

22. After both tractors are secured, you may use the horizontal adjustment knob (**13**) to make fine horizontal paper adjustments.

## Reloading Paper

---

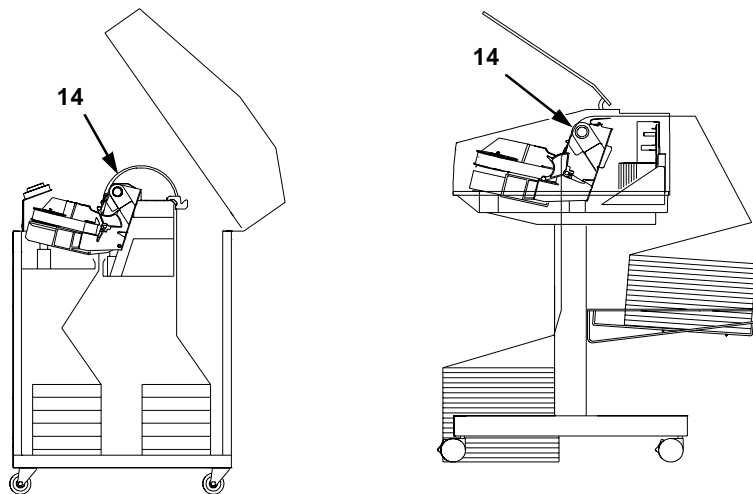

23. On pedestal models:  
Using the vertical position knob to move the paper up, guide the paper over the lower paper guide (**14**) and through the slot in the top cover. Close the platen and the printer cover.
24. Press FF several times to make sure the paper feeds properly beyond the tractors and over the lower paper guide (**14**). Feed sufficient paper to ensure the paper stacks correctly.
25. On cabinet models: Open the cabinet rear door. Make sure the paper is aligned with the label in the output area (inside the cabinet). Close the front and rear doors.

## Chapter 3 Operational Procedures

---

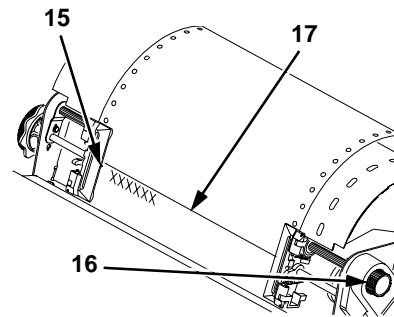

26. Locate the TOF indicator (15). It is the small tab located on both the right and left tractor door.
27. Turn the vertical position knob (16) to align the top of the first print line with the TOF indicator. For best print quality, it is recommended the top-of-form be set at least 1/2 inch below the perforation (17).

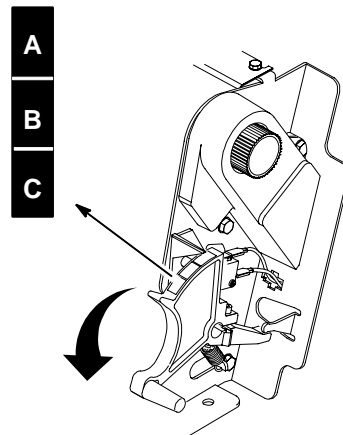

28. Lower the forms thickness lever. Set it to match the paper thickness. (The A-B-C scale corresponds approximately to 1-, 3-, and 6-part paper thickness. Adjust until you have the desired print quality.)
29. Press CLEAR to clear any fault messages (such as "LOAD PAPER") from the Liquid Crystal Display.

## Unloading Paper

---

30. Press SET TOF. The top-of-form you have set moves down to the print position. If there are data in the buffer, the paper moves forward to the last print position on the next page.
31. Press ONLINE and close the printer cover.

## Unloading Paper

---

1. Press ON LINE to place the printer in offline mode, and open the printer cover.
2. For cabinet models, open the cabinet rear door.

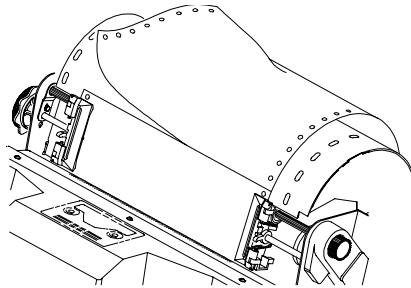

3. Tear off the paper at the perforation.
4. Allow the paper to fall to the back of the printer and into the paper stacking area.

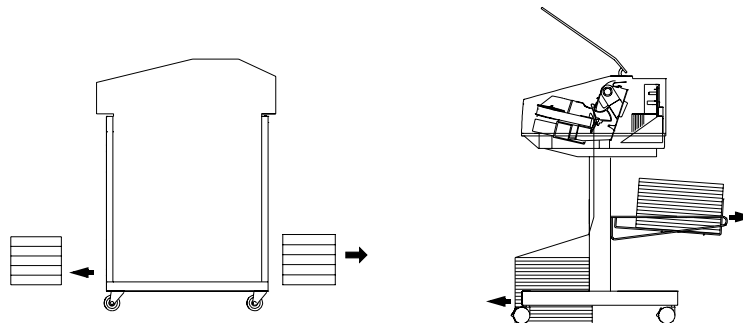

5. For pedestal models, remove the stacked paper from the paper tray.
6. For cabinet models, remove the stacked paper from the cabinet floor.

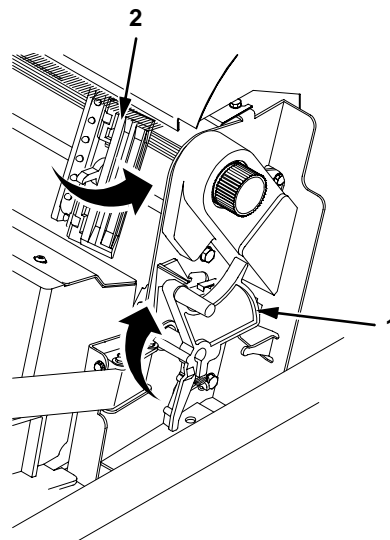

7. To completely remove the paper from the printer:
  - a. Raise the forms thickness lever (1) as far as it will go, and open both tractor doors (2).

**CAUTION** Be careful when pulling any paper backward through the paper path, especially when using a label stock. If you are not careful, labels can detach and adhere to the printer within the paper path, where only an authorized service representative can remove them.

- b. Remove the paper from the tractors. For cabinet models, open the cabinet front door. Gently pull the paper down through the paper slot. Allow the paper to fall into the paper supply area.
- c. Remove the paper from the paper supply area.



### Replacing the Ribbon

---

1. Press ON LINE to place the printer in offline mode.
2. Open the printer cover.

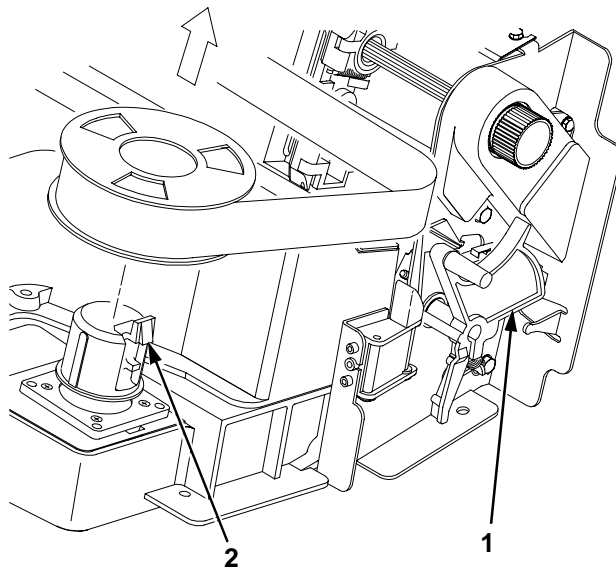

3. Remove the old ribbon:
  - a. Raise the forms thickness lever (**1**) as far as it will go.
  - b. Press in on the hub latches (**2**) and lift the ribbon spools off the hubs. Lift the ribbon out of the ribbon path.
4. Discard the old ribbon.
5. If necessary, clean the interior of the printer. (See "Cleaning Requirements" on [page 195](#).)

## Chapter 3 Operational Procedures

6. Install the new ribbon:
  - a. With the ribbon to the outside, place the full spool on the right hub (3). Press down on the spool until the hub latch snaps in place.

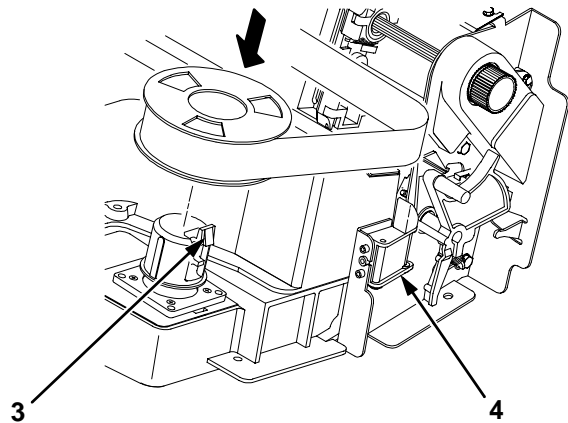

- b. Thread the ribbon around the ribbon guide (4) and along the ribbon path. (Refer to the ribbon path diagram on the shuttle cover.) Be sure to thread the ribbon between the hammer bank cover and the ribbon mask.

**CAUTION** The ribbon must not be twisted. A twisted ribbon can lower print quality, shorten ribbon life, or cause paper jams.

- c. Place the empty spool on the left hub. Press down on the spool until the hub latch snaps into place.
  - d. Hand turn the empty spool to make sure the ribbon tracks correctly in the path and ribbon guides.

## Replacing the Ribbon

---

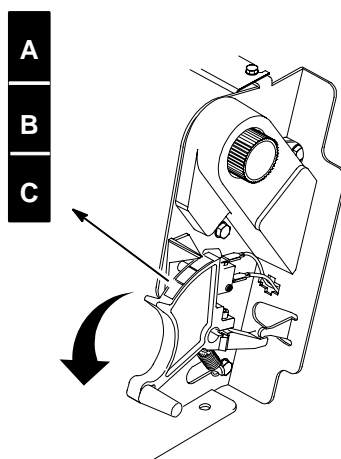

7. Lower the forms thickness lever. Set it to match the paper thickness. (The A-B-C scale corresponds approximately to 1-, 3-, and 6-part paper thickness.)

**NOTE:** Do not set the forms thickness lever too tightly; excessive friction can cause paper jams, ribbon jams with potential for ribbon damage, smeared ink, or wavy print.

8. Close the printer cover.
9. Press ON LINE to return the printer to online mode.

## Canceling a Print Job

---

The procedure to cancel a print job depends on the printer emulation and your application software. Contact your System Administrator for additional information.

1. If the printer is online, press ON LINE to place the printer in offline mode.
2. From the host system, stop the print job.

**NOTE:** If the print job is not stopped from the host system before pressing CLEAR + ENTER, the print job continues with data missing when the printer returns to online mode. Exercise caution to prevent unwanted data loss occurrences, as this function deletes unprinted data in the printer. This function is active only in offline mode; the purpose of this function is to eliminate the necessity of printing unwanted data when print jobs are canceled.

3. Press CLEAR + ENTER.
4. Set the top-of-form (see "Set the Top-of-Form" on [page 38](#)).

---

# 4

## *The Configuration Menus*

---

### **Configuration Overview**

---

In order to print data, the printer must respond correctly to signals and commands received from the host computer. Configuration is the process of matching the printer's operating characteristics to those of the host computer and to specific tasks, such as printing labels, or printing on different sizes of paper. The characteristics which define the printer's response to signals and commands received from the host computer are called configuration parameters.

You can configure the printer using the configuration menus and the control panel, or by sending control codes in the data stream from a host computer attached to the printer. This chapter provides an introduction to configuring the printer, as well as all the configuration menus available (depending on which emulation you have installed in the printer).

**IMPORTANT** Configuration directly affects printer operation. Do not change the configuration of your printer until you are thoroughly familiar with the procedures in this chapter.

## Changing and Saving Parameter Settings

---

You may change a printer parameter setting, such as line spacing or forms length, either by pressing keys on the control panel to configure the printer's resident set of configuration menus, or by sending emulation control codes from a host attached to the printer (the host data stream). An example procedure for using the control panel to change parameter settings begins on [page 64](#).

When control codes are sent from a host attached to the printer, they override control panel settings. For example, if you set the line spacing to 6 lpi with the control panel, and application software later changes this to 8 lpi with a control code, the control code overrides the control panel setting.

The parameter settings that you have changed using the menus and control codes can be permanently stored in the printer's memory if you save them to printer memory using the "Save Config." menu option. If you do not save your changes, they will be lost when the printer is powered off.

There are no host control codes that allow you to save a parameter as a custom configuration.

## Default and Custom Configurations

---

A configuration consists of a group of parameter settings, such as line spacing, forms length, etc. Your printer provides a fixed default configuration and also allows you to define several custom configurations for use with particular print jobs.

The factory default configuration can be loaded, but it cannot be altered.

Eight configurations can be modified for unique print job requirements. The "Save Config." option allows you to save eight groups of parameter settings in memory as custom configurations numbered from 1 through 8. An explanation on how to save a set of parameter values as a custom configuration using the "Save Config." menu option begins on [page 66](#).

## Navigating the Menus

---

To manipulate configurations it is important to understand how to navigate through the menus. Review the following instructions before you begin making changes to the printer.

You must be offline to move within the menus.

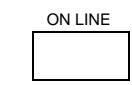
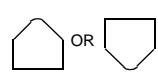
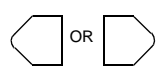
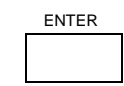
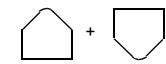
- |   |  |
|---|--|
|   | Press to toggle between online and offline modes.  |
|  | Press to move up or down through the menu levels.  |
|  | Press to scroll through the available choices on a chosen level.   |
|  | Press to confirm selection.  |
|  | Press to lock and unlock the ENTER key. The ENTER key is locked by default, to prevent you from accidentally changing the printer configuration. |

When the printer is online, the LCD displays ONLINE and the type of emulation on the second line.

To experiment with navigating the menus, follow the example on the next page as a tutorial.

## Changing Parameters Example

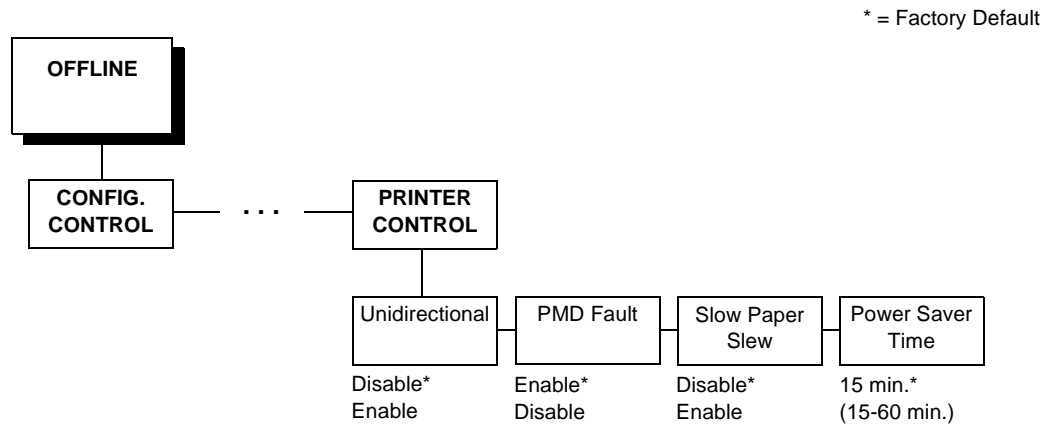















A configuration consists of several parameters. The default factory configuration has a starting set of parameters. In the configuration menu above, and in all the configuration menus in this chapter, the factory default values are indicated by an asterisk (\*).

Your print jobs may require parameter values which vary from the default settings. This section provides an example procedure for changing individual parameter values.





The following procedure shows how to change and save the settings for the Unidirectional and Slow Paper Slew options. Use these basic guidelines to navigate the configuration menus and change other parameters.



## Changing Parameters Example

Step	Press	LCD	Notes
1.	Make sure the printer is on. Raise the printer cover.		
2.	ON LINE 	OFFLINE CONFIG. CONTROL	
3.	 + 	ENTER SWITCH UNLOCKED	Allows you to make configuration changes.
		OFFLINE CONFIG. CONTROL	
4.	 UNTIL	OFFLINE PRINTER CONTROL	
5.		PRINTER CONTROL Unidirectional	
6.		Unidirectional Disable*	
7.	 OR 	Unidirectional Enable	Cycle through the choices.
8.	ENTER 	Unidirectional Enable*	The * indicates this choice is active.
9.		PRINTER CONTROL Unidirectional	
10.	 UNTIL	PRINTER CONTROL Slow Paper Slew	
11.		Slow Paper Slew Disable*	
12.	 OR 	Slow Paper Slew Enable	Press until the desired parameter displays.

## Chapter 4 Configuration Overview

Step	Press	LCD	Notes
13.	ENTER 	Slow Paper Slew Enable*	The * indicates this choice is active.
14.	 + 	ENTER SWITCH LOCKED	
15.	ON LINE 	ONLINE LinePrinter+	
16. Close the printer cover. The printer is ready for operation.			

The parameters you have changed remain active as long as the printer is on. When you turn off the printer, the parameters are erased from memory unless you save them in a configuration. If you do not save the configuration, the printer reverts to the default values next time the printer is powered on.

The next section, “Saving Your New Configuration”, will explain how to save configurations.

### Saving Your New Configuration

Once you have changed all of the necessary parameters, it is recommended you save them as a configuration that can be stored and loaded for future use. If you do not save your configuration before you power off the printer, all of your parameter changes are erased. The Save Config. option allows you to save up to eight configurations to meet different print job requirements. (Configurations 1 through 8 are empty until you save values to them using the Save Config. option.)





## Saving Your New Configuration

---



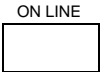
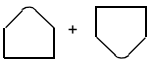



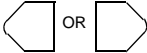

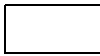

Once you have saved a custom configuration using this option, it is not lost if you power off the printer. You can load a configuration for a specific print job (see “Load Config.” on [page 71](#)). You can also modify and resave it. You may want to print your configurations (see “Print Config.” on [page 72](#)) and store them in a safe place, such as inside the printer cabinet.

If the Protect Configs. parameter is enabled, and you try to resave an existing configuration, the new configuration will not be saved until the existing configuration has been deleted (see [page 72](#)).

**NOTE:** Once you change active emulations, any changes to the previously selected emulation will be gone unless they have been saved.

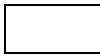
Step	Press	LCD	Notes
1.	Make sure the printer is on. Raise the printer cover.		
2.		OFFLINE CONFIG. CONTROL	Allows you to make configuration changes.
3.		ENTER SWITCH UNLOCKED	
		OFFLINE CONFIG. CONTROL	
4.		CONFIG. CONTROL Load Config.	
5.		CONFIG. CONTROL Save Config.	
6.		Save Config. 1*	
7.		Save Config. 2	

## Chapter 4 Configuration Overview

Step	Press	LCD	Notes
8.	ENTER 	Save Config. 2*	The * indicates this choice is active.
<b>NOTE:</b> It is recommended you print the configuration. To print the configuration go to Step 9. To skip this procedure and resume printer operation, go to Step 14.			
9.		CONFIG. CONTROL Save Config.	
10.	 UNTIL	CONFIG. CONTROL Print Config.	
11.		Print Config. Current	
12.	 OR 	Print Config. 2	Press until the desired parameter displays.
13.	ENTER 	OFFLINE CONFIG. CONTROL	The selected configuration is printed.
14.	 + 	ENTER SWITCH LOCKED	Locks the ENTER key.
15.	ON LINE 	ONLINE LinePrinter+	
16. Close the printer cover. If you printed out the configuration, store it in a safe place. The printer is ready for operation.			

# Main Menu

<sup>1</sup> If installed

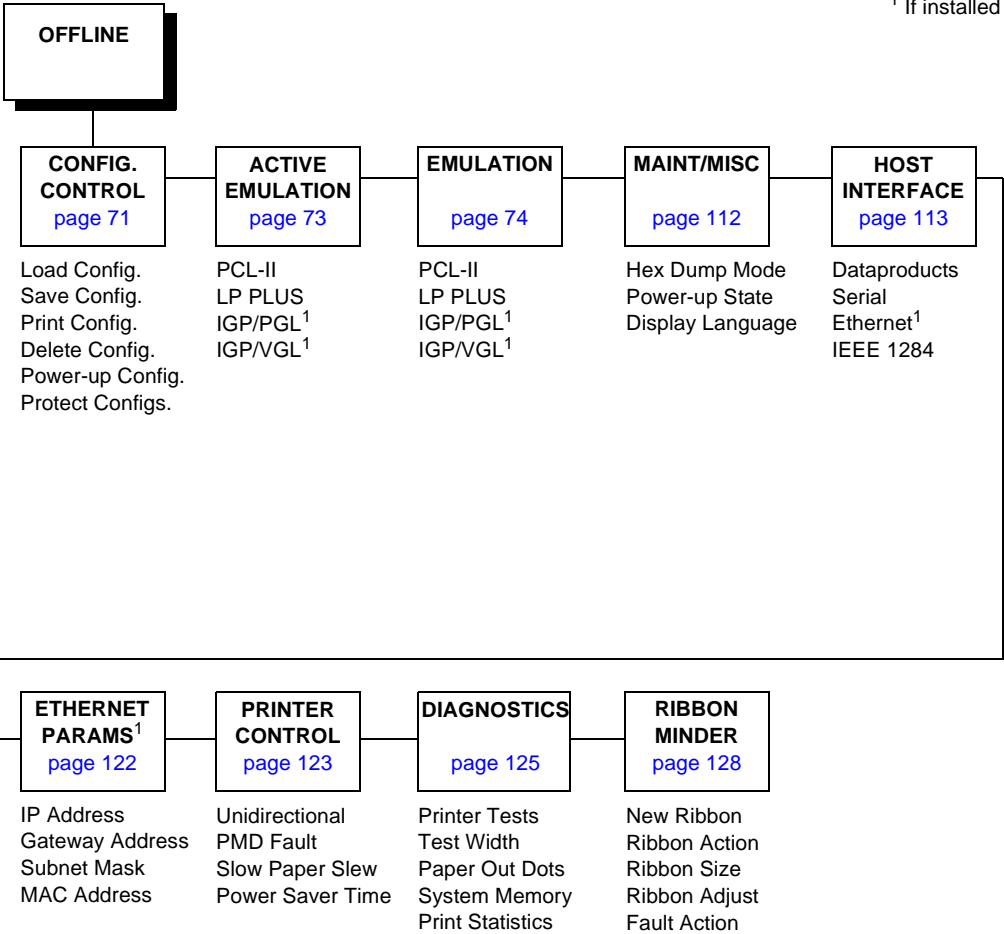

Figure 12. Configuration Main Menu

## Chapter 4 Configuration Overview

---

Brief descriptions follow for the first-level configuration menu options:

- **CONFIG. CONTROL** — These options allow you to save, print, load, delete, name, and protect entire sets of configuration parameters, as well as select the default power-up configuration.
- **ACTIVE EMULATION** — This menu allows you to select the active emulation: PCL-II or LinePrinter+. The optional IGP/PGL or IGP/VGL emulations can be selected if they are installed.
- **EMULATION** — This menu allows you to configure the options which are available for the current operating (active) emulation. For example, if LinePrinter+ is the active emulation, then the LinePrinter+ emulation options can be configured using this menu.
- **MAINT / MISC** — These options provide miscellaneous functions, such as printing a hex dump, selecting a display language, and choosing whether the printer will power up in offline or online mode.
- **HOST INTERFACE** — These options allow you to select either the Serial RS-232, Serial RS-422, Dataproducts® Long Line, Ethernet™, or IEEE1284 parallel interface for the printer (which must match the interface cabling you installed while setting up your printer, described in Chapter 2). This menu also allows you to configure several parameters for each interface.
- **ETHERNET PARAMS** — This option allows you to view and change the IP Address, Gateway Address, and Subnet Mask. The MAC Address may also be viewed.
- **PRINTER CONTROL** — These options allow you to select several operating parameters for the printer, such as the speed at which paper will advance when slewing.
- **DIAGNOSTICS** — These options include the diagnostic tests, system memory, and statistics of the printer.
- **RIBBONMINDER** — The options in this submenu allow you to enable the RibbonMinder™ feature and set its parameters.

## CONFIG. CONTROL

The CONFIG. CONTROL menu allows you to control your printer's configurations according to the specifications necessary for your print jobs.

### Menu

\* = Factory Default

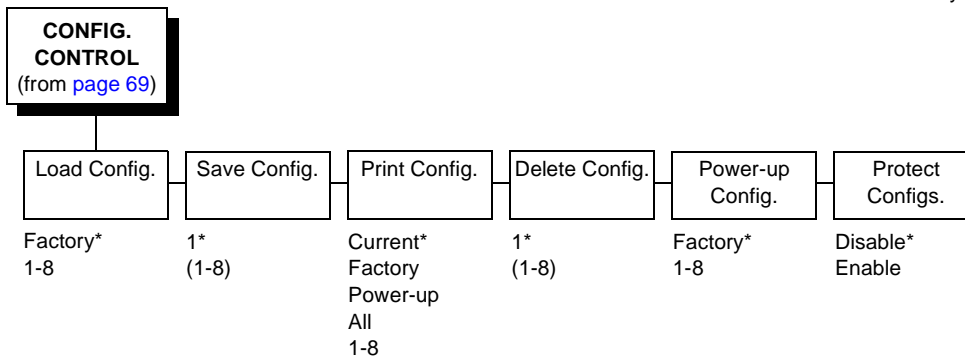

### Load Config.

The printer can store numerous configurations in memory. This parameter allows you to select and load a specific configuration.

### **Save Config.**

This option allows you to save up to eight unique configurations to meet different print job requirements. This eliminates the need to change the parameter settings for each new job. The configurations are stored in memory, and will not be lost if you turn off the printer. If the Protect Configs. parameter is enabled, the new configuration will not be saved unless the existing configuration has been deleted first. The factory default configuration cannot be changed. See “Saving Your New Configuration” on [page 66](#) for details.

### **Print Config.**

This option is used to print a listing of various stored printer configurations. It is recommended you store printouts of your configurations in a safe place for quick referral.

### **Delete Config.**

You can delete one or all of your eight customized configurations. The factory default configuration cannot be deleted.

### **Power-Up Config.**

You can specify which of the nine configurations (Factory or 1-8) will be the power-up configuration.

### **Protect Configs.**

You can specify whether or not a new configuration should overwrite an existing configuration when you activate the Save Configs. parameter. When disabled (default), the new configuration will overwrite the existing configuration. When enabled, the new configuration will *not* overwrite the existing configuration, and the message “CONFIG. EXISTS / Delete First” displays.



---

## ACTIVE EMULATION

---

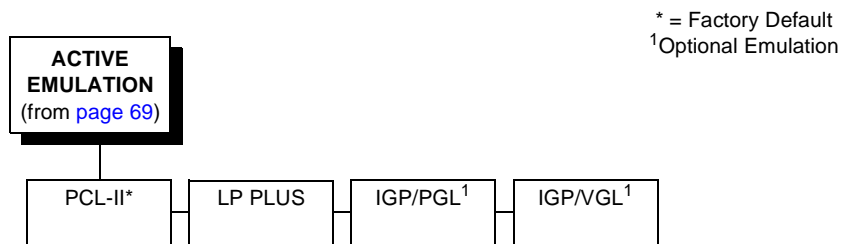

The ACTIVE EMULATION function allows you to activate either the PCL-II or LinePrinter Plus emulation, as well as the optional IGP/PGL or IGP/VGL emulations, if they are installed. There are two methods for selecting the desired emulation. The first is by selecting the emulation directly from the printer menu. The second is by sending a host command which will switch the emulation automatically (see the appropriate *Programmer's Reference Manual* for details).

When changing from one emulation to the other, the printer will load the power-up configuration. Thus, any configuration settings performed before selecting these emulations and not saved in NVRAM will be lost.

### IMPORTANT

**In order to configure an emulation, the emulation must be selected in the ACTIVE EMULATION menu. The emulation that is not selected will not appear in the EMULATION menu (see "EMULATION" on [page 74](#)).**

## EMULATION

The EMULATION menu is the gateway to configure the emulations available with your printer. The control codes for each of these emulations are described in their respective *Programmer's Reference Manuals*.

\* = Factory Default  
¹Optional Emulation

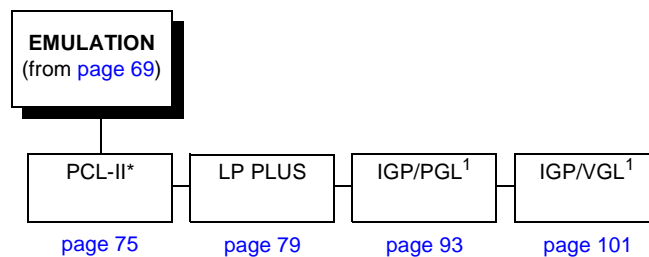

### PCL-II Emulation

Hewlett-Packard's Printer Control Language that is compatible with Compaq systems.

### LinePrinter Plus Emulations

- **Epson FX.** This LP Plus emulation is provided for compatibility with the Epson FX-1050 printer control language.
- **Proprinter XL.** This LP Plus emulation is provided for compatibility with the IBM Proprinter III XL printer control language.
- **P-Series.** This is the Printronix P-Series printer control language, provided as part of LP Plus.

### Optional Emulations

IGP/VGL (Code V) and IGP/PGL are optional graphics emulations. They can be selected and configured only if you have purchased these options. PCL-II must be the active emulation for Code V or IGP/PGL to operate.

## PCL-II Emulation

\* = Factory Default

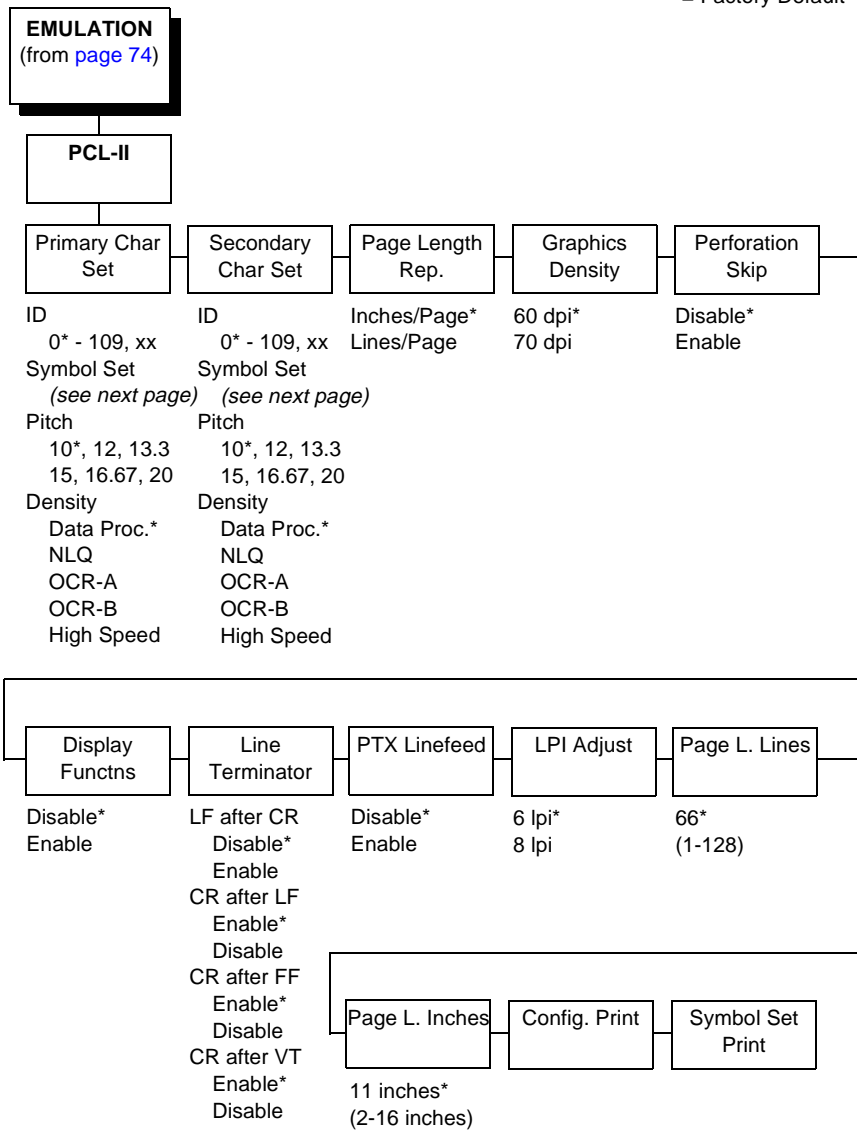

## Chapter 4 EMULATION

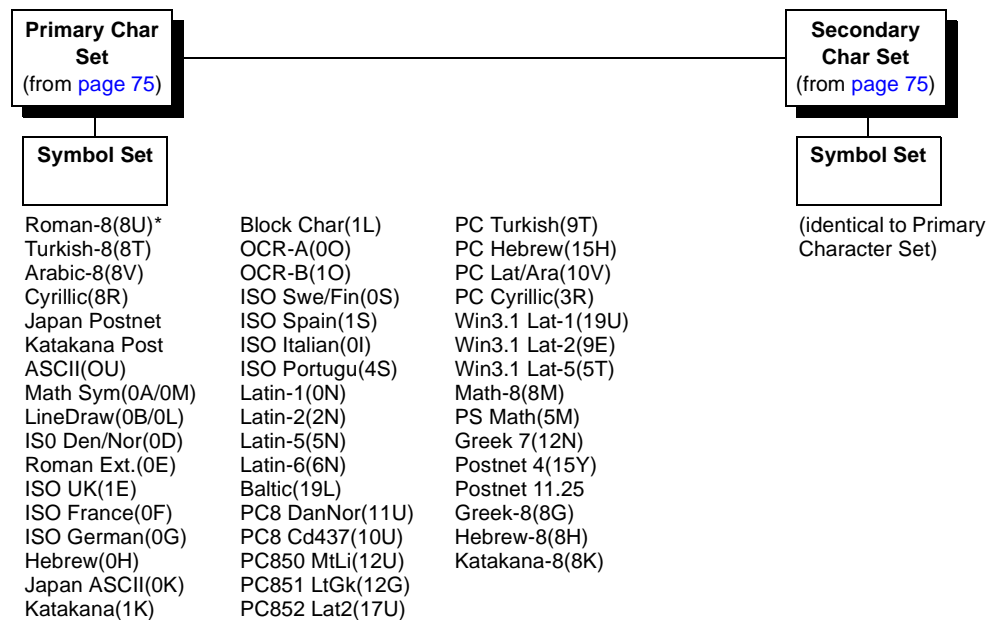

### Primary Character Set

You can select one of 92 pre-defined character sets by ID (although character sets range from 0 - 109, not all sets are available on the Compaq series printer), or you can select pitch, symbol set, and typeface individually. If the combination you choose matches one of the 92 predefined sets, the ID submenu will reflect that selection. If not, the ID menu will display "xx" to indicate that the current character set does not match a pre-defined set. Set 0 is the default and its attributes are 10 cpi, Data Processing typeface, and Roman 8 symbol set.

### Secondary Character Set

Your printer can store an additional character set. To toggle between them, send the Shift In (Decimal 15, to select the Primary character set) or Shift Out (Decimal 14, to select the Secondary character set) command code.

### Page Length Representation

- **Inches/Page.** All page length calculations are based on the inches displayed on the panel.
- **Lines/Page.** All page length calculations are based on the number of lines per page displayed on the panel.

For example, if the form in use is 82 lines at 6 lpi, the page is physically 13.67 inches. Since 13.67 inches is not selectable from the Length in Inches menu, change the representation to lines, then set the number of lines to 82. The inches menu will display 13.6 inches although the printer internally keeps the exact form length of 13.67 inches.

### Graphics Density

Graphics can be printed in 60 DPI (the default) or 70 DPI.

### Perforation Skip

- **Disable.** Allows printing on page perforation.
- **Enable.** The printer sets up a skip-over margin to prevent printing on the page perforation.

### Display Functions

- **Disable.** The default. Control characters are not printed.
- **Enable.** Control characters are printed before they get executed. This is a useful debugging tool.

### Line Terminator

You can specify what will be used to indicate the end of a line. Four options are available: LF after CR, CR after LF, CR after FF, and CR after VT. Each of these options may be Enabled or Disabled independent of one another.

### PTX Linefeed

- **Disable.** The default. Linefeed is performed as calculated from the bottom of the graphics or barcode, thereby disrupting the vertical text alignment.
- **Enable.** The Linefeed moves to the next line as calculated from the Top of Form position, thereby retaining vertical text alignment. When printing graphics or bar codes, you may want to set the PTX Linefeed parameter to Enable to maintain text alignment.

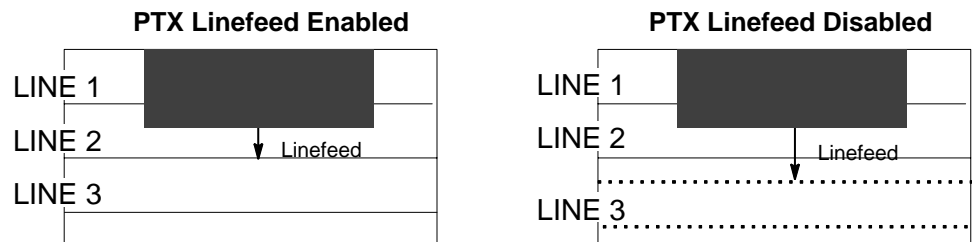

### LPI Adjust

This parameter lets you specify the lines per inch (lpi) values, 6 LPI (the default) or 8 LPI.

### Page Length Adjust/Lines

This parameter lets you set physical page length from 1 to 128 lines. The default is 66 lines.

### Page Length Adjust/Inches

This parameter lets you set physical page length from 2 to 16 inches, in increments of half an inch. The default is 11 inches.

### Config. Print

This option prints the emulation's parameters and the currently selected values.

### Symbol Set Print

This option prints a list of all the available sets. The character set number prints to the left of the character set sample.

## LinePrinter Plus Emulation

\* = Factory Default

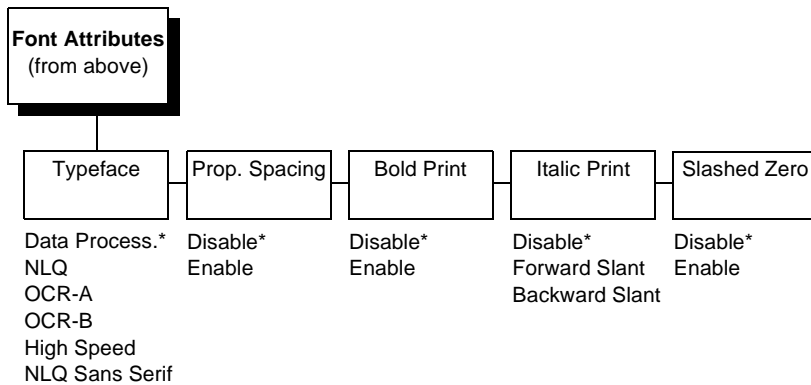
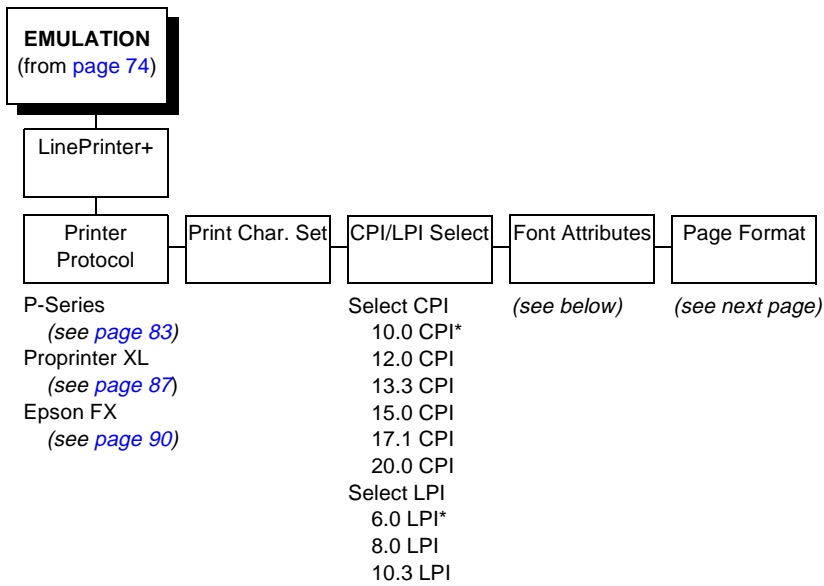

## Chapter 4 EMULATION

### Page Format (from page 79)

\* = Factory Default

Margins	Perforation Skip	Form Length	Form Width
Left Margin 0* columns (0-369)	Disable* 1/2 inch 2/3 inch	Abs. Length IN 11.0* inches (0.1-24)	Abs. Width IN 13.6* inches (0.1-13.6)
Right Margin 0* columns (0-369)	5/6 inch 1 inch	Abs. Length MM 279.4* millimeters (0.1-609.6)	Abs. Width MM 345.4* millimeters (0.1-345.4)
Bottom Margin 0* lines (0-451)		Funct. of Lines 66* lines (1-192)	Funct. of CPI 136* Characters (1-272)

### Printer Protocol

Select the LinePrinter+ protocol you wish to use. Refer to the *LinePrinter Plus Programmer's Reference Manual* for more information.

### Print Char Set

When this selection is displayed and the ENTER key is pressed, the current character set is printed.

### CPI/LPI Select

This parameter lets you specify the characters per inch (cpi) and lines per inch (lpi) values.

### Font Attributes

#### Typefaces

- **Data Processing.** A general purpose font printing at 120 dpi horizontally and 72 dpi vertically. The width of the font varies with each cpi.
- **NLQ.** A high quality font with serifs printing at 180 dpi horizontally and 96 dpi vertically. The width of the font varies with the cpi.



## LinePrinter Plus Emulation

---

- **OCR-A / OCR-B.** Optical character recognition fonts printing at 120 dpi horizontally and 144 dpi vertically. Both fonts print only at 10 cpi.
- **High Speed.** A draft quality font printing at 120 dpi horizontally and 48 dpi vertically. The width of the font varies with the cpi.
- **NLQ Sans Serif.** A high quality font printing at 180 dpi horizontally and 96 dpi vertically. This font prints without serifs. The width of the font varies with the cpi.

### Proportional Spacing

Each printed character is contained inside a character cell. The width of the character cell includes the character and the space around the character.

- **Disable.** Each character cell is printed with the same width. Each column in the printed text will line up.

```
This example is printed with
proportional spacing disabled.
```

- **Enable.** The width of each character cell varies with the width of the character. For example, [i] takes less space to print than [m]. Using proportional fonts generally increases the readability of printed documents, giving text a typeset appearance.

```
This example is printed with
proportional spacing enabled.
```

### Bold Print

- **Disable.** Text is printed normally.
- **Enable.** Text is printed with a heavy line thickness.

### Italic Print

- **Disable.** Text is printed normally.
- **Forward Slant.** Text is printed with a forward slant.
- **Backward Slant.** Text is printed with a backward slant.

### Slashed Zero

This parameter allows you to print the numeral “0” with or without the slash. This option applies to all character sets except OCR-A and OCR-B.

- **Disable.** Zero is printed without a slash.
- **Enable.** Zero is printed with a slash.

### Page Format

#### Margins

- **Left Margin.** Set in columns. Column zero is defined as the far left edge of the page, and column numbering increments from left to right.
- **Right Margin.** Set in columns. Column zero is defined as the far right edge of the page, and column numbering increments from right to left.
- **Bottom Margin.** Defined in lines, starting from line zero at the bottom of the page and incrementing from the bottom up.

#### Perforation Skip

- **Disable.** Allows printing on page perforation.
- You may set up a skip-over margin of 1/2 inch, 2/3 inch, 5/6 inch, or 1 inch. For example, a skip-over margin of 1 inch allows a 1 inch margin at the bottom of the page.

#### Forms Length

Forms length is the number of lines that can be printed on a page. You can set forms length in inches, millimeters (mm), or as a function of the current LPI (lines per inch).

#### Forms Width

The forms width can be specified in inches, millimeters, or as a function of the current CPI (characters per inch). The forms width set should not exceed the actual paper width.

## P-Series Emulation

\* = Factory Default

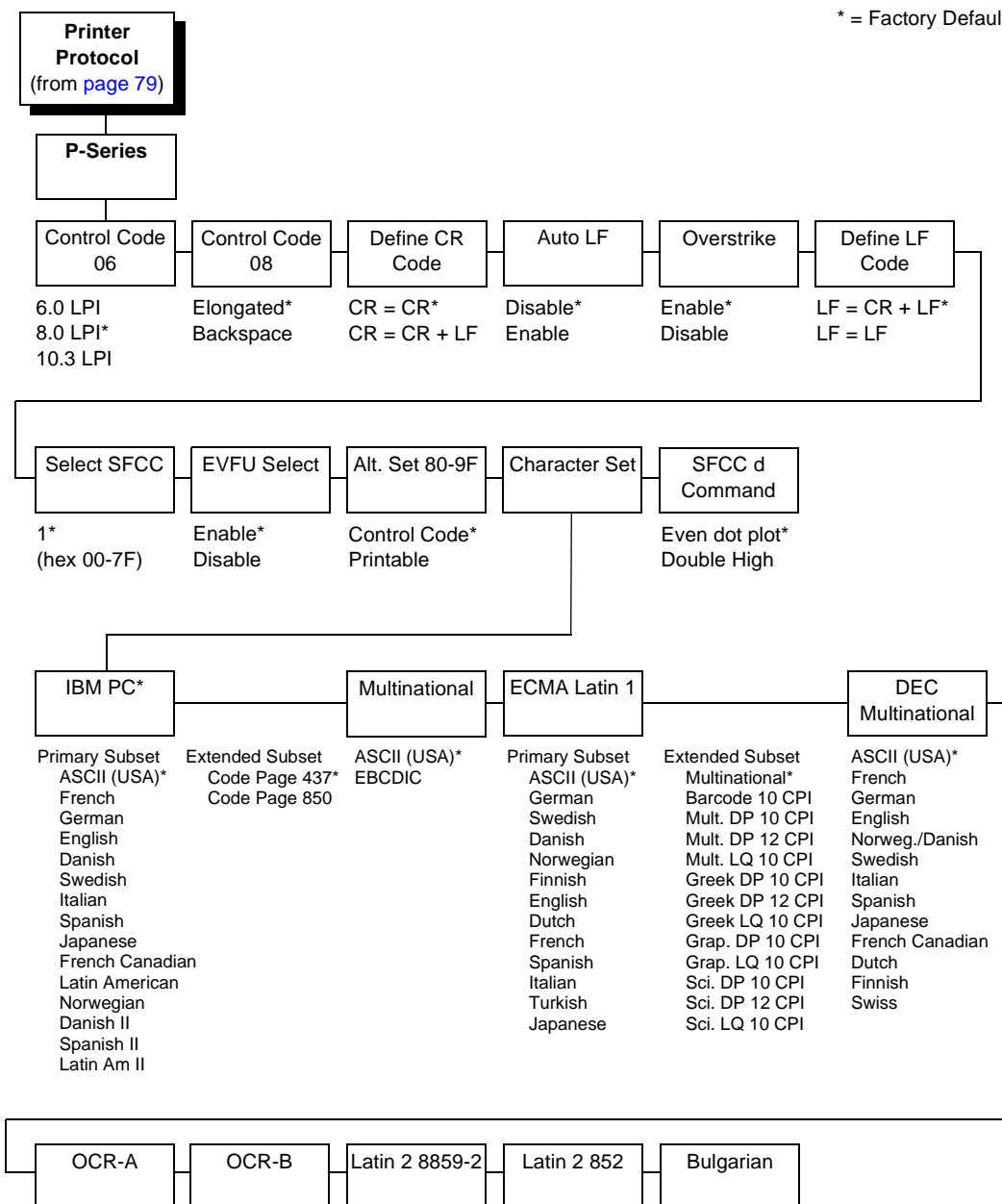

### Control Code 06

Control Code 06 defines the function of ASCII code hex 06 (ACK). You can select an alternate line spacing of 6, 8 or 10.3 LPI.

### Control Code 08

Control Code 08 defines the function of ASCII code hex 08 (BS). You can define the code to output an elongated character or a backspace.

### Define CR Code

This option controls the action of the printer when it receives a Carriage Return code (hex 0D) from the host computer. If this feature is enabled, each time the printer receives a Carriage Return, it inserts an additional Line Feed code (hex 0A) into the data stream. Do not use this feature if the host computer sends Line Feeds to the printer.

- **CR = CR.** Does not insert an extra Line Feed after each Carriage Return.
- **CR = CR + LF.** Inserts an extra Line Feed after each Carriage Return. The next print position will be print position 1 of the next line.

### Auto LF

This option defines the printer action when print data is received past the forms width setting.

- **Disable.** Discards any data past the forms width.
- **Enable.** Performs an automatic carriage return and line feed when data is received past the forms width.

## Overstrike

- **Enable.** Common dots appear darker in characters printed over each other, as shown below. The print position moves one-half dot to the right. Overstrike printing occurs at a decreased speed.
- **Disable.** If you are using a control code for overstrike, but it is disabled in the printer control panel, no bolding will occur.

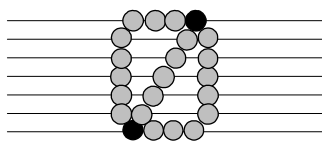

## Define LF Code

- **LF = CR + LF.** Forces an automatic carriage return with each line feed command. The next print position is print position 1 of the next line.
- **LF = LF.** Does not perform an automatic carriage return. The next print position will be the current print position of the next line.

## Select SFCC

This parameter allows you to select which ASCII codes will function as the Special Function Control Code (SFCC) command delimiter.

P-Series codes can use hex 00 through hex 7F. Options include the following:

- ESC (hex 1B)
- SOH (hex 01)
- ETX (hex 03)
- CIRCUMFLEX (hex 5E)—also called caret (^)
- TILDE (hex 7E)—(~)

**NOTE:** SOH, ETX and ESC are non-printables. The characters (^) and (~) are printable; however, do not use them as printables in the host data stream if either is chosen as a delimiter, or print errors will occur.

### **EVFU Select**

Controls how the printer handles vertical formatting.

- **Enable.** Enables the VFU and selects P-Series compatible Electronic Vertical Format Unit (EVFU).
- **Disable.** Disables all VFU processing.

### **Alt. Set 80-9F**

Determines whether the printer processes ASCII codes hex 80 through hex 9F as control codes or as printable characters.

### **Character Set**

Specifies a character set. To use one of these sets, choose the desired set and press ENTER. Two groups of character sets (IBM PC and ECMA Latin 1) have Primary and Extended Subsets. To use one of these sets, choose the group name and press ENTER, then choose the desired set within the Primary or Extended subset and press ENTER. Both the group and the desired set will be starred to indicate your selection.

### **SFCC d Command**

- **Even dot plot.** This option interprets SFCC d Command as even dot plot.
- **Double high.** This option interprets SFCC d Command as double high. Select this option for backward compatibility.

## Proprinter XL Emulation

\* = Factory Default

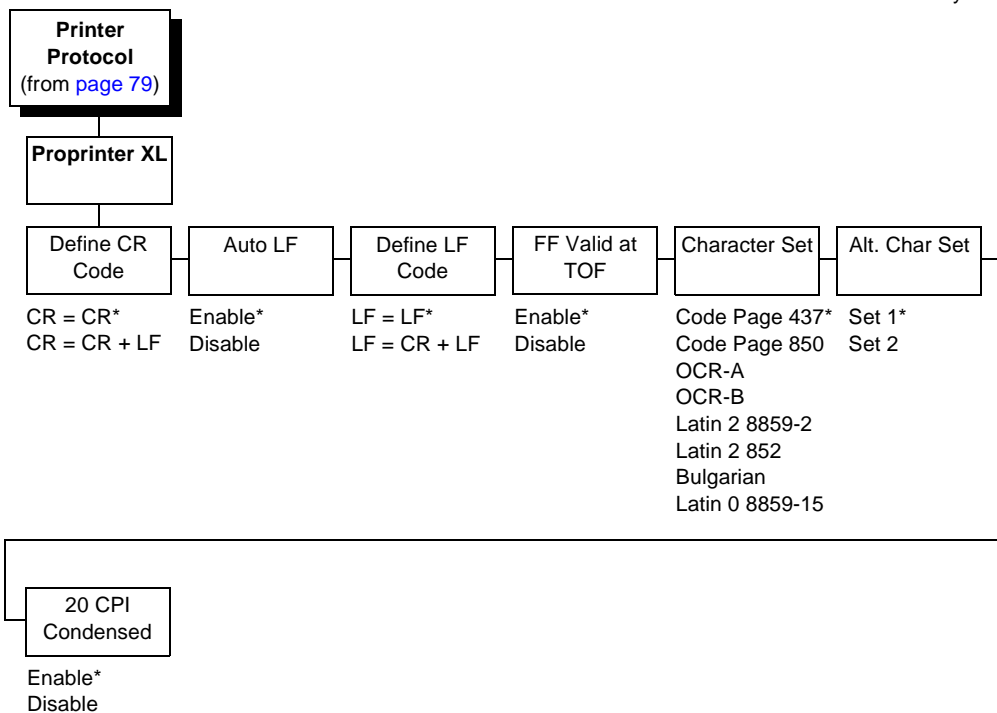

### Define CR Code

This option controls the action of the printer when it receives a Carriage Return code (hex 0D) from the host computer. If this feature is enabled, each time the printer receives a Carriage Return, it inserts an additional Line Feed code (hex 0A) into the data stream. Do not use this feature if the host computer sends Line Feeds to the printer.

- **CR = CR.** Does not insert an extra Line Feed after each Carriage Return.
- **CR = CR + LF.** Inserts an extra Line Feed after each Carriage Return.

### Auto LF

This option defines the printer actions when print data is received past the forms width setting.

- **Enable.** Performs an automatic carriage return and line feed when data is received past the forms width.
- **Disable.** Discards any data past the forms width.

### Define LF Code

- **LF = LF.** Does not perform an automatic carriage return when a line feed command is received. The next print position will be the current print position of the next line.
- **LF = CR + LF.** Forces an automatic carriage return with each line feed command received. The next print position is print position 1 of the next line.

### FF Valid at TOF

- **Enable.** Performs a form feed when the host sends a Form Feed command and the printer is at the top of form.
- **Disable.** Will not perform a form feed when the host sends a Form Feed command and the printer is at the top of form.

### Character Set

Specifies a character set. To use one of these sets, choose the desired character set and press ENTER.



### Alternate Char Set

This option determines if data in the range of hex 80 through hex 9F should be interpreted as a control code or as a printable character.

- **Set 1.** Interprets data in the range of hex 80 through hex 9F as a control code.
- **Set 2.** Prints data for the characters at hex locations 03, 04, 05, 06, 15 and 80 through 9F.

### 20 CPI Condensed

Compressed print characters are narrower than the normal character set. This is helpful for applications where you need to print the maximum amount of information on a page.

- **Enable.** Prints characters about 60 percent the width of normal characters when compressed print is chosen by the host computer.
- **Disable.** Does not compress print widths, even if condensed print is chosen by the host.

## Epson FX Emulation

\* = Factory Default

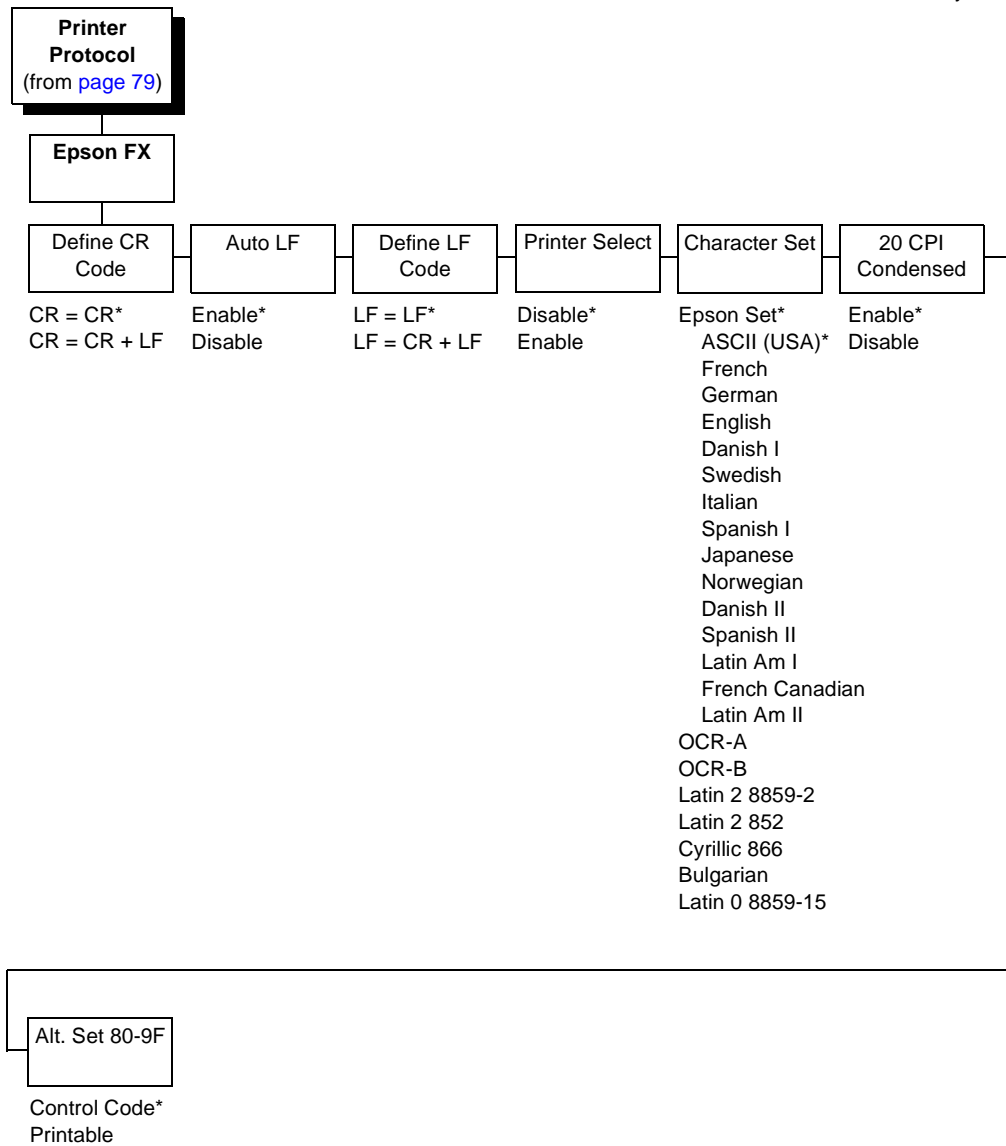

### Define CR Code

The Define CR Code option controls the action of the printer when it receives a Carriage Return code (hex 0D) from the host computer. If this feature is enabled, each time the printer receives a Carriage Return, it inserts an additional Line Feed code (hex 0A) into the data stream. Do not use this feature if the host computer sends Line Feeds to the printer.

- **CR = CR.** Does not insert an extra Line Feed after each Carriage Return.
- **CR = CR + LF.** Inserts an extra Line Feed after each Carriage Return.

### Auto LF

This option defines the printer actions when print data is received past the forms width setting.

- **Enable.** Performs an automatic carriage return and line feed when data is received past the forms width.
- **Disable.** Discards any data past the forms width.

### Define LF Code

The Define LF Code option controls the action of the printer when it receives a Line Feed code (hex 0A) from the host computer. If this feature is enabled, each time the printer receives a Line Feed, it inserts an additional Carriage Return code (hex 0D) into the data stream. This feature is required if the host computer does not send Carriage Returns to the printer.

- **LF = LF.** Does not add a Carriage Return with a Line Feed.
- **LF = CR + LF.** Adds an extra Carriage Return with each Line Feed.

### Printer Select

- **Disable.** Ignores the ASCII DC1 and DC3 control codes.
- **Enable.** Disables the printer when a DC1 control code is received, and enables the printer when a DC3 control code is received.

### Character Set

Specifies a character set. To use one of these sets, choose the desired character set and press ENTER.

Note that when OCR-A or OCR-B is selected as the print language, the Font Attribute Typeface option under the LinePrinter Plus menu ([page 80](#)) is changed to OCR-A or OCR-B, respectively.

### 20 CPI Condensed

Compressed print characters are narrower than the normal character set. This is helpful for applications where you need to print the maximum amount of information on a page.

- **Enable.** Prints about 60 percent of the width of normal characters when compressed print is chosen by the host computer. For example, a 12 CPI Draft font will compress to 20 CPI.
- **Disable.** Does not compress print widths, even if condensed print is chosen by the host.

### Alternate Set 80-9F

- **Control Code.** Interprets data in the range of hex 80 through hex 9F as a control code.
- **Printable.** Prints data in the range of hex 80 through hex 9F.

## IGP/PGL Submenu

---

The IGP/PGL emulation is the software based Intelligent Graphics Processor (IGP). It is based upon, and is compatible with, the Printronix IGP-100/200/400 board using the Printronix Graphics Language (PGL). The IGP/PGL graphics processing features are detailed below.

### Features

**On-Line Form and Label Generation** makes it easy to create forms or labels with a “preprinted” look for each application. IGP/PGL programs control all graphic functions, dramatically reducing host computer programming and processing time.

Graphic capabilities include boxes, vertical and horizontal lines with user-selectable thickness, logos, and special alphanumeric print features. Forms and graphic designs can be duplicated horizontally and vertically.

Alphanumeric data can appear as prepositioned “fixed” information (entered when the form is created), be overlaid onto the form (positioned in a specific location after the form is created), or may be dynamically merged with the form.

**Selectable Bar Codes** provide you with the appropriate bar code for your application using standard wide-to-narrow ratios. A wide selection of bar codes are available: Codabar, Code 39, Code 93, Code 128 Subset A, B, and C, EAN 8, EAN 13, FIM, Interleaved 2 of 5, German I-2/5, ITF-14, Matrix, MSI A through D, PDF417, POSTNET, PostBar, Royal Mail, UCC/EAN-128, UPC-A, UPC-E, and UPS 11. UPC and EAN bar codes can specify add-on data.

**Expanded and Compressed Character Print** attract attention where needed. Alphanumeric height and width are controlled independently for a wide range of character sizes up to 139 times the standard character size (up to 11.3 inches wide and tall). Compressed print sizes of 10, 12, 13, 15, 17 and 20 characters per inch (cpi) are available.

**Logos** are created using alphanumeric commands and add many print and shading features for a “customized” appearance to forms, reports, and labels.

**Rotated Alphanumerics** permit new concepts in form design. Normal, expanded, and compressed character strings can be rotated 90 degrees clockwise or counterclockwise, or they can be printed upside down.

**Reversed Print** permits highlighting and contrasting by printing white characters on a dark background.

**Automatic Increment/Decrement Capability** allows batch form processing. You can identify individual numeric and bar code data fields, which includes automatic increment or decrement functions.

**Scaling Capability** permits graphic elements, such as corners or boxes, to retain their physical shapes and sizes when printed in a horizontal and vertical density other than the base density of 60 x 72 dpi.

**Multinational Character Sets** provide 32 international character sets, each 96 characters in length. This feature also allows you to create your own character sets using characters defined and stored in memory.

### **Configuring the Emulation with the Control Panel**

You can select IGP/PGL default parameters directly from the control panel, or by control codes as explained in the *IGP/PGL Programmer's Reference Manual*. The IGP/PGL parameters are described on the following pages. Parameters marked with an asterisk (\*) indicate the default value. The printer must be offline to enter the configuration structure.

Pressing an invalid key to enter a parameter value may move you to another level in the configuration or exit the configuration menu completely. Configure the IGP/PGL according to your specific requirements.

**IMPORTANT** **BEFORE** you reconfigure the IGP/PGL, print a configuration sheet to see all of the current settings.

**IGP/PGL Submenu**

\* = Factory Default

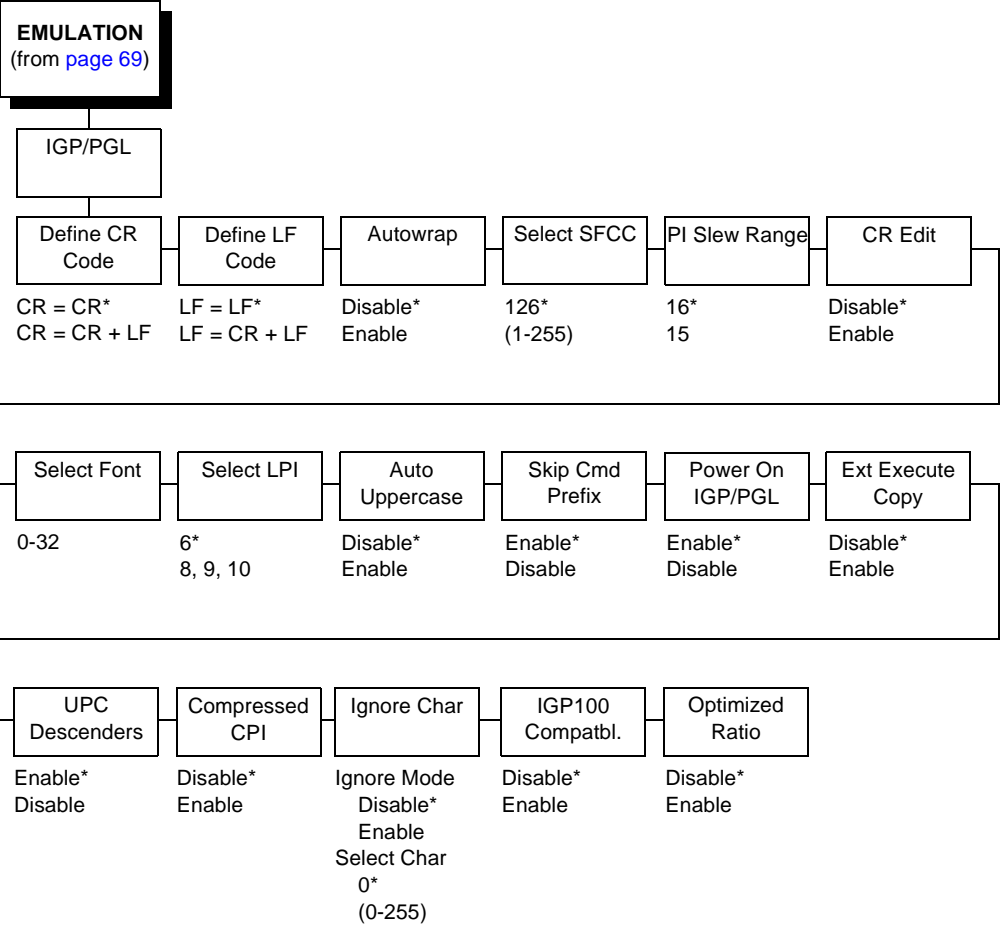

### Define CR Code (Carriage Return)

This parameter forces the printer to insert an automatic Line Feed code into the data stream whenever a Carriage Return code occurs. This is to be used only if the host computer does not send Line Feeds to the printer.

- **CR = CR.** Does not perform a line feed. The next print position will be print position 1 of the current line.
- **CR = CR + LF.** Performs an automatic line feed. The next print position will be print position 1 of the next line.

### Define LF Code (Line Feed)

This parameter forces the printer to insert an automatic Carriage Return code into the data stream whenever a Line Feed code occurs. This can be used in most installations, but it is required if the host computer does not send Carriage Returns to the printer.

- **LF = LF.** Does not perform an automatic carriage return. The next print position will be the current print position of the next line.
- **LF = CR + LF.** Performs an automatic carriage return. The next print position will be print position 1 of the next line.

### Autowrap

This parameter determines if text will wrap to the next line when the line of text exceeds the right margin.

- **Disable.** Truncates the text beyond the right margin until a CR or CR + LF is received.
- **Enable.** Automatically inserts a CR + LF after a full print line.

### Select SFCC

You can specify which decimal code (1-255) will be used as the Special Function Control Code (SFCC). The factory default setting is 126. The SFCC denotes that the following data is an IGP/PGL command.



### PI Slew Range

You can specify how many lines the paper will feed.

- **15.** A paper slew of 1-15 will move 1-15 lines. A paper slew of 0 will move 1 line.
- **16.** A paper slew of 0-15 will move 1-16 lines.

### CR Edit

This parameter determines if a carriage return will be followed by a line feed.

- **Disable.** The printer ignores all carriage returns that are not followed by line feeds.
- **Enable.** The printer processes all carriage returns, even for those that are not followed by line feeds.

### Select Font

This parameter allows you to select a font for the IGP/PGL feature. The default is 0, which is U.S. ASCII. The following values are valid choices:

0	U.S. ASCII
1	German
2	Swedish
3	Danish
4	Norwegian
5	Finnish
6	English
7	Dutch
8	French
9	Spanish
10	Italian
11	Turkish

Values 12-23 are undefined and will default to 0. You can set values 24-32 to specific fonts; refer to the USET command in the *IGP/PGL Programmer's Reference Guide*.

### Select LPI

This is the number of lines to be printed per inch. For example, at 6 lpi there is 1/6 inch from the top of one print line to the top of the next print line.

### Auto Uppercase

This parameter enables the printer to print text in all uppercase when using the ALPHA command.

- **Disable.** The printer will print text in upper and lowercase.
- **Enable.** The printer will print text in uppercase only.

### Skip Command Prefix

This parameter determines if the printer will print any data before an IGP/PGL command is received.

- **Enable.** The printer ignores all data on the current line before an IGP/PGL command.
- **Disable.** The printer will print all data on the current line before an IGP/PGL command.

### Power On IGP/PGL

You can set the IGP/PGL feature so that it is enabled or disabled when the printer is powered on.

- **Enable.** The IGP/PGL is enabled when the printer is powered on. (The IGP/PGL feature is initialized in the Normal mode.)
- **Disable.** The IGP/PGL is disabled when the printer is powered on. (The IGP/PGL feature is initialized to the Quiet mode.)

### Extended Execute Copy

- **Disable.** Dynamic data, overlay data, etc. are not allowed if the optional Form Count parameter (number of forms to print) is specified as part of the Execute command. (This setting is IGP-100 compatible.)
- **Enable.** Dynamic data, overlay data, etc. are allowed within a form in which the Form Count parameter is specified in the Execute command. In this case, the exact same form (with identical dynamic data, etc.) is printed for whatever the Form Count is. However, incremental data is not incremented since the page that is printing is exactly the same. Also, each form is printed on a separate page.

### UPC Descenders

This parameter allows you to print bar code descenders when human readable data is not presented in the UPC/EAN bar codes.

- **Enable.** UPC/EAN bar codes are printed with descenders, even if there is no human readable data.
- **Disable.** UPC/EAN bar codes are printed without descenders if there is no human readable data.

### Compressed CPI

This parameter allows you to choose a compressed character (60% shorter) for 17 or 20 CPI instead of the normal height character.

- **Disable.** The IGP/PGL does not use compressed 17 or 20 CPI font.
- **Enable.** Uses the standard compressed 17 or 20 CPI font.

### Ignore Character

#### Ignore Mode

This parameter instructs the IGP/PGL to ignore the character selected under the Select Character menu.

- **Disable.** The IGP/PGL does not ignore any characters.
- **Enable.** The IGP/PGL ignores the characters specified in the Select Character menu.

### Select Character

Instructs the IGP/PGL which decimal character (0-255) to ignore from the host.

### IGP100 Compatbl.

This option instructs the IGP/PGL to behave similar to the IGP-100 with respect to certain commands. All new users with new applications should select the "Disable" option. Selecting this mode insures the printer behaves as described in this manual.

- **Disable.** The IGP/PGL does not emulate the IGP-100 mode.
- **Enable.** The IGP/PGL emulates the IGP-100 version.

### Optimized Ratio

This option selects different bar code ratios for certain bar codes including Code 39 and Interleaved 2 of 5. It is included for compatibility with the IGP-X00 printers.

- **Disable.** Use standard bar code ratios.
- **Enable.** Select the alternate bar code ratios.

## IGP/VGL Emulation

---

Code V Graphics language (VGL) is an Intelligent Graphics Printing (IGP) software emulation designed for your line matrix printer. The IGP Code V emulation of the QMS<sup>®</sup> Code V Version II programming language produces on-line forms, bar codes, and alphanumeric text-generation. The graphics processing features are detailed below.

### Features

**On-Line Form and Label Generation** makes it easy to create forms or labels with the “preprinted” look for each application. VGL programs control all graphics functions, dramatically reducing host computer programming and processing time. Graphics capabilities include boxes, vertical and horizontal, solid and dashed lines with a variety of thickness, logos, and special alphanumeric print features.

**Variable Bar Codes** allow the bar code for your application to print with standard or user-defined ratios in vertical or horizontal orientations. Available bar codes are: Codabar, Code 39, Code 93, Code 128 with Subsets A, B, and C, EAN 8, EAN 13, Identicon, Interleaved 2 of 5, MSI, UPC-A, UPC-E, POSTNET, Royal Mail, UCC/EAN 128, UPS 11, and UPC Shipping. POSTNET is available only in the horizontal direction. A dark print mode is included for darker, high-contrast bar codes. The IBARC bar code command prints bar codes in four orientations: horizontal, rotated 90, rotated 180 or rotated 270 degrees.

**Expanded and Compressed Print** draws attention where needed. Alphanumeric height and width are controlled independently for a tremendous range of character sizes up to 9.9 inches wide and tall. Several compressed print sizes are available: 12, 13.33, 15, 17.65, and 20 cpi (characters per inch), permitting up to 170 columns in an 8.5 inch printed area (20 cpi).

**Rotated Alphanumerics** permit new concepts in form design. Normal, expanded, and compressed character strings can be rotated 90 degrees clockwise, counterclockwise, or printed upside down.

**Logos** are easily created using alphanumeric commands and a variety of print and shading features, providing a “customized” appearance for forms, reports, and labels. The registered trademark, copyright, TUV<sup>®</sup>, GS-Mark, UL<sup>®</sup>, and CSA<sup>®</sup> symbols are provided as standard designs on the Code V, and you can also define custom symbols.

**Reverse and Shaded Print** permit highlighting and contrasting by printing white characters on a dark background or white characters on a gray, shaded background. Various levels or patterns of gray shading and reverse printing may combine with the many other print features to create distinctive designs.

**Automatic Increment/Decrement Capability** allows batch form processing. Individual alphabetic, numeric, and bar code data fields can be identified and automatically incremented or decremented by any amount, beginning from a specified reference point.

**Standard Character Sets** provide you with many different character sets. Based on the Multinational Character Set, you may create your own character sets using characters defined and stored in flash memory.

### Configuring the Emulation with the Control Panel

You can select Code V default parameters directly from the control panel, or by control codes as explained in the *IGP/VGL Programmer's Reference Manual*. The Code V parameters are described on the following pages. Parameters marked with an asterisk (\*) indicate the default value. The printer must be offline to enter the configuration structure.

Pressing an invalid key to enter a parameter value may move you to another level in the configuration or exit the configuration menu completely. Configure the IGP/VGL according to your specific requirements.

**IMPORTANT** BEFORE you reconfigure the IGP/VGL, print a configuration sheet to see all of the current settings.

## IGP/VGL Emulation

\* = Factory Default

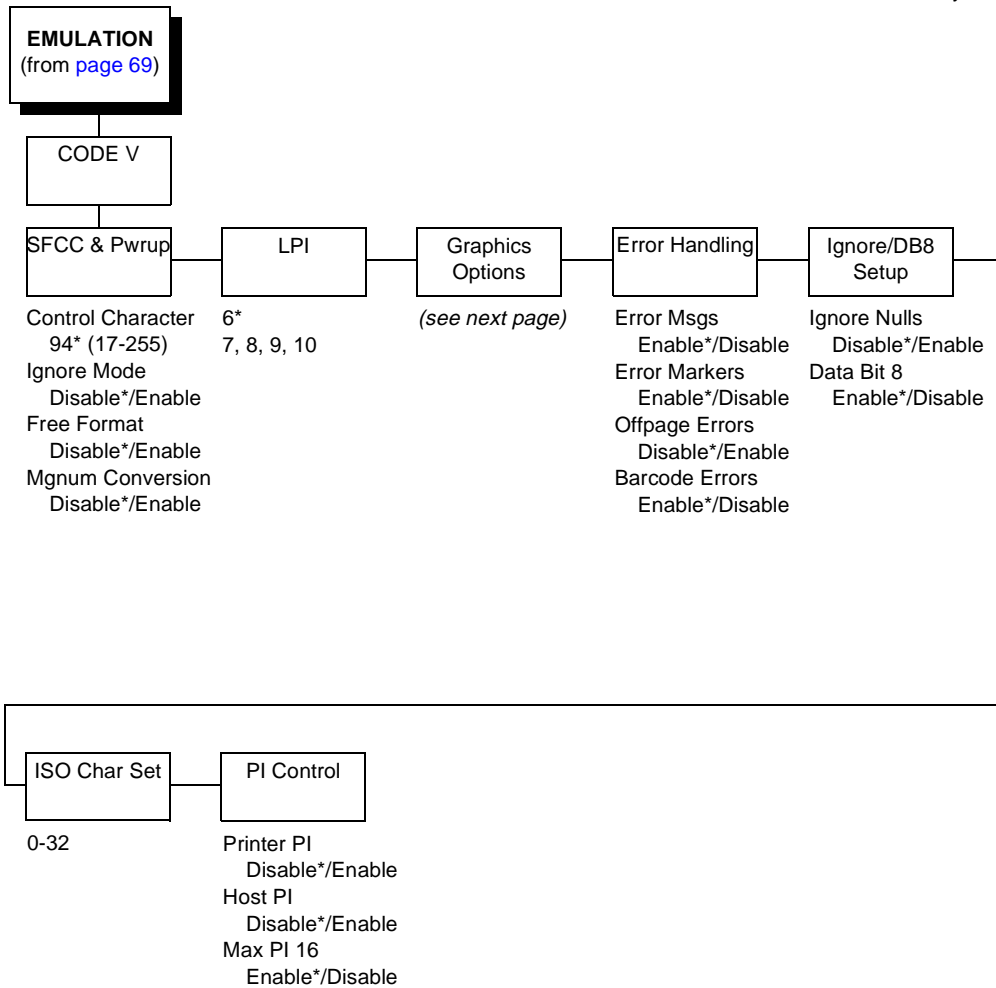

## Chapter 4 EMULATION

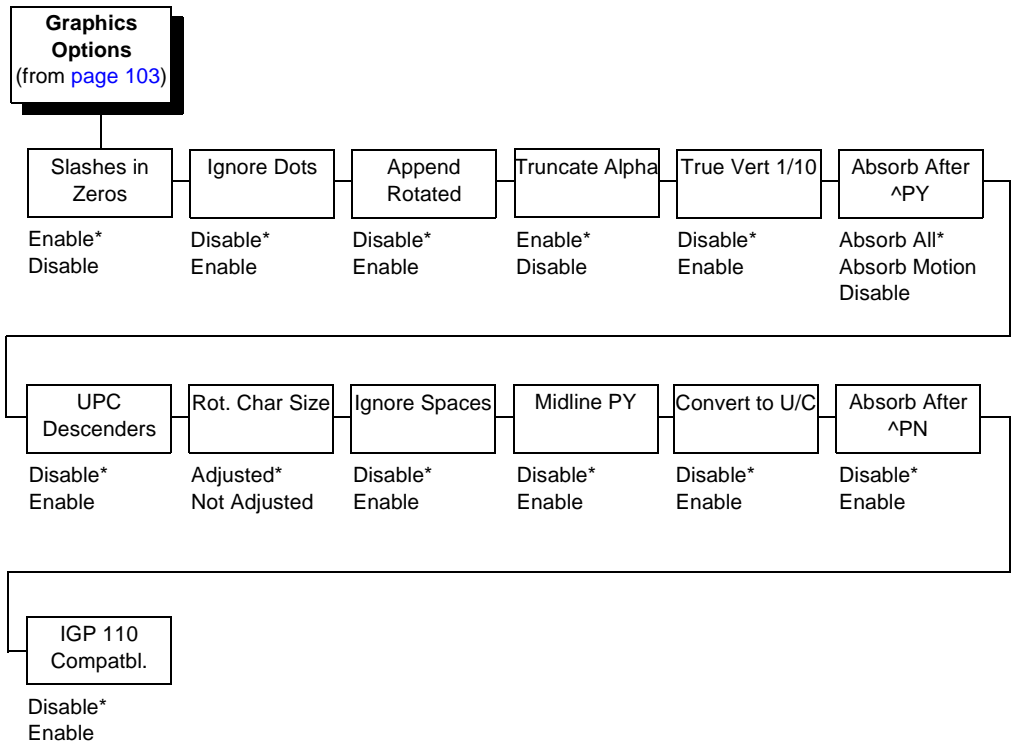

### SFCC & Pwrup

This option has several suboptions which define the SFCC and power-up configuration used with Code V.

#### Control Character

This option selects the Special Function Control Code (SFCC). The default value is the caret ^ (decimal 94). Valid values are 17 through 255. Throughout this section, the caret is used as the SFCC. Run a configuration printout to determine the currently selected SFCC.



### Ignore Mode

- **Disable.** The default.
- **Enable.** Selects the ignore mode as the power-up default, and selects the graphics mode ^PY as the power-up default. All characters are ignored until a ^A command is received.

### Free Format

- **Disable.** The default.
- **Enable.** Selects free format mode as the power-up default, and selects the graphics mode ^PY as the power-up default. Free format causes the Code V to ignore carriage returns, line feeds and all characters below hex 20 sent from the host.

### Mgnum Conversion

- **Disable.** The default.
- **Enable.** Selects the graphics mode ^PY as the power-up default.

### LPI

The number of lines to be printed per inch. For example, at 6 lpi there is 1/6 inch from the top of one print line to the top of the next print line.

### Graphics Options

Following are several options which configure printing output.

#### Slashes in Zeros

This parameter allows you to print the numeral "0" with or without the slash. This option applies to all character sets except OCR-A and OCR-B.

- **Disable.** Zero is printed without a slash.
- **Enable.** Zero is printed with a slash.

### Ignore Dots

- **Disable.** The default.
- **Enable.** Causes the Code V to expect position values to be specified in only 1/10ths of an inch. If the dot position is also given, it is treated as text.

### Append Rotated

- **Disable.** Logos and alphanumeric strings are treated as separate elements.
- **Enable.** Appends logos to an alphanumeric string rotated in a clockwise, counterclockwise, or inverted orientation.

### Truncate Alpha

When enabled, this parameter prevents the printing of Error 48 (Element Off Page Error) if alphanumeric data, including spaces, extends beyond the right side of the form.

### True Vert 1/10

- **Disable.** A vertical 1/10 of an inch parameter is used as 7/72 of an inch. The absolute move is slightly smaller than expected. For example, a one inch move would be 70/72 of an inch. Vertical moves that have the same value will be identical in length.
- **Enable.** A vertical 1/10 of an inch parameter is used as 1/10 of an inch. Rounding occurs to the nearest 1/72 of an inch. This can cause vertical moves that have the same value to differ by  $\pm 1/72$  of an inch.

### Absorb after ^PY

- **Absorb All.** The system ignores all the data and terminator until a host generated terminator is detected.
- **Absorb Motion.** Prevents paper motion following a system terminator in a graphics ^PY command.
- **Disable.** System terminators following a graphics command are sent to the printer and result in paper motion.

### UPC Descenders

- **Disable.** UPC/EAN bar codes are printed without descenders if there is no human readable data.
- **Enable.** UPC/EAN bar codes are printed with descenders, even if there is no human readable data.

### Rot. Char Size

- **Adjusted.** Rotated (clockwise/counterclockwise), expanded characters have a different size than an unrotated character with the same size parameters.
- **Not Adjusted.** Rotated, expanded characters will be the same size as unrotated characters with the same size parameters.

### Ignore Spaces

- **Disable.** Trailing spaces are not deleted from alphanumeric elements in a graphics pass.
- **Enable.** Trailing spaces are deleted from alphanumeric elements in a graphics pass.

### Midline PY (includes ^PN)

- **Disable.** The Graphics mode Enable command, ^PY, must be the first three characters of a line.
- **Enable.** The ^PY or ^PN can occur anywhere in a line.

### Convert to U/C

- **Disable.** Lowercase characters are printed normally.
- **Enable.** All lowercase alphabetic characters are converted to uppercase.

### Absorb After ^PN

- **Disable.** All line terminators that immediately follow the ^PN command are sent to the printer and processed.
- **Enable.** All line terminators that immediately follow the ^PN command are ignored.

### IGP 110 Compatbl.

This option instructs the Code V to behave similar to the IGP-110 with respect to certain commands. All new users with new applications should select the “Disable” option. Selecting this mode insures the printer will behave as described in this manual.

- **Disable.** The Code V does not emulate the IGP-110 mode.
- **Enable.** The Code V emulates the IGP-110 version.

### Error Handling

Following are several options which define how errors are reported.

#### Error msgs

- **Enable.** Command syntax is checked and error messages printed when command parameters are incorrect.
- **Disable.** Error checking and error messages are suppressed.

#### Error markers

- **Enable.** Prints the following error markers for those elements that print beyond the page boundaries:
  - >> for elements that begin off the right side of the page;
  - << for elements that begin at the indicated position but end off the page;
  - ◆ for elements where the starting position of the command contains an error other than an off-page error.

### Offpage Errors

- **Disable.** Does not report errors for elements that start or end beyond the right edge of the page.
- **Enable.** Reports errors for elements that start or end beyond the right edge of the page.

### Barcode Errors

- **Enable.** An error message will print when invalid bar code data is encountered.
- **Disable.** Code V will not print an error for illegal bar code data; the bar code will be skipped.

**NOTE:** When Barcode Errors is disabled, the Code V emulation will try to make the best use of invalid data by either truncating extra digits or adding zeros to the end of bar code data to meet minimum data length requirements for some bar codes. Not all errors will be corrected.

### Ignore / DB8 Setup

Following are several options which define character filtering and data bit 8.

#### Ignore Nulls

- **Disable.** None of the null characters (hex 00 or hex 80) are ignored.
- **Enable.** Null characters are filtered out of the data stream.

#### Data Bit 8

- **Enable.** The PI line is not passed directly from host to printer; all 8 bits are used for data bits, and characters in the hex 80-FF range can be accessed.
- **Disable.** When the host PI line is enabled, data bit 8 internally indicates PI line status. To use the PI line, disable data bit 8, and enable the Host PI configuration option (under the PI Control option, below).

**NOTE:** Data bit 8 is interpreted as either data bit 8 or PI signal, but never both. When enabled as data bit 8, data bit 8 has priority over the PI signal, and all data above hex 7F is used to access character data and not to interpret PI line data.

Conversely, when data bit 8 is disabled and the PI signal is used, data bit 8 of the data is reserved for use as the PI function, and you cannot access characters in the hex 80-FF range. Therefore, to access characters in the hex 80-FF range, data bit 8 must be enabled.

### ISO Char Set

This parameter allows you to select a font for the Code V feature. The default is 0, which is U.S. ASCII. The following values are valid choices:

0	U.S. ASCII
1	United Kingdom
2	Swedish/Finnish
3	Norwegian/Danish
4	Japanese
5	German
6	French
7	Italian
8	Spanish
9	PC Subset
10	Code V Version I

Values 11-23 are undefined and will default to 0. You can set values 24-32 to specific fonts; refer to the User Set command in the *IGP/VGL Programmer's Reference Guide*.

### PI Control

#### Printer PI

- **Disable.** The ASCII emulation is configured with the PI line disabled.
- **Enable.** The ASCII emulation is configured with the PI line enabled.

### Host PI

- **Disable.** The host does not send PI signals.
- **Enable.** The host sends PI signals. The Data Bit 8 configuration option must be disabled to transmit the PI line to the printer.

### Max PI 16

- **Enable.** A paper slew of 0-15 will move 1-16 lines.
- **Disable.** A paper slew of 1-15 will move 1-15 lines. A paper slew of 0 will always move 1 line.

## MAINT / MISC

---

### Menu

---

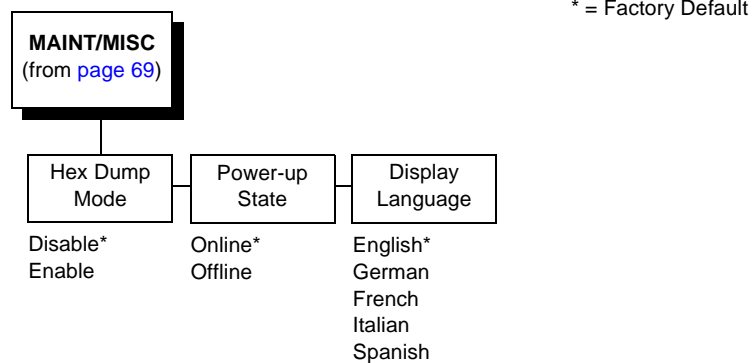

### Hex Dump Mode

A hex code printout (or hex dump) translates all incoming data to hexadecimal equivalents. A hex dump lists each ASCII data character received from the host computer, together with its corresponding two-digit hexadecimal code. Hex dumps can be used to troubleshoot some types of printer data reception problems. [Figure 15](#) on [page 199](#) shows a hex dump sample.

### Power-Up State

- **Online.** The printer powers up in the online state.
- **Offline.** The printer powers up in the offline state.

### Display Language

This parameter chooses the language that will appear on the LCD: English, German, French, Italian, or Spanish.



---

## HOST INTERFACE

---

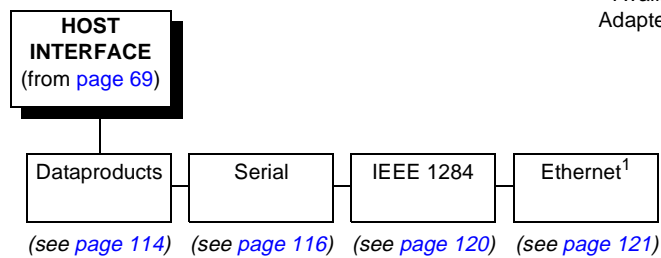

<sup>1</sup> Available when an Ethernet Adapter is present.

The Host Interface Menu enables you to select and configure one of many types of interfaces between the printer and your host computer. The currently selected interface is indicated with an asterisk on the control panel message display. Each interface has its own submenu with a set of interface parameters which can be configured.

## Dataproducts Submenu

\* = Factory Default

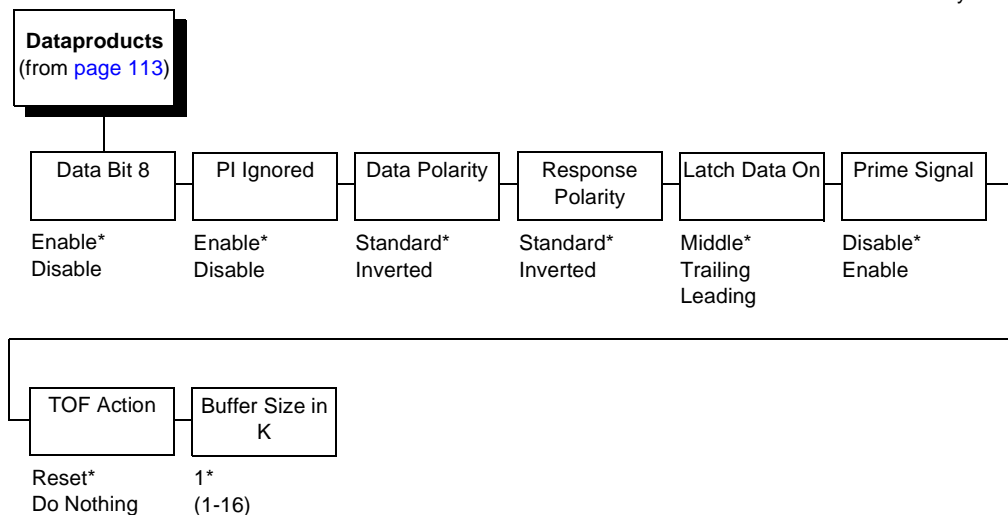

### Data Bit 8

- **Enable.** Allows access to the extended ASCII character set.
- **Disable.** The printer interprets bit 8 of each incoming data character as a zero, regardless of its actual setting.

### PI Ignored

The PI (Paper Instruction) signal is used to control vertical paper motion.

- **Enable.** Causes the printer to interpret the eight data lines as DVFU commands when the PI signal is true.
- **Disable.** Ignores the PI signal and treats the data as characters or control codes.

### Data Polarity

The Data Polarity parameter must be set to match the data polarity of your host computer.

- **Standard.** Does not expect the host computer to invert the data.
- **Inverted.** Expects the data received on the data lines from the host computer to be inverted. Ones become zeros, and zeros become ones.

### Response Polarity

The Response Polarity parameter must be set to match the response polarity of your host computer.

- **Standard.** Does not invert the response signal.
- **Inverted.** Inverts the response signal sent to the host computer.

### Latch Data On

Specifies whether the data is read on the leading, middle, or trailing edge of the data strobe signal.

### Prime Signal

- **Enable.** The parallel port will perform a warm start (reboot) if the host asserts the Prime Signal.
- **Disable.** The parallel port will not perform a warm start (reboot) if the host asserts the Prime Signal.

### TOF Action

- **Reset.** A form feed is performed before a warm start when the prime signal is asserted from the host. This setting is used only if the Prime Signal parameter is enabled.
- **Do Nothing.** Nothing occurs before a warm start when the prime signal is asserted from the host.

## Chapter 4 HOST INTERFACE

### Buffer Size in K

Configures the amount of memory allocated for the Dataproducts parallel port buffer. You can specify between 1 and 16 Kbytes, in 1-Kbyte increments.

### Serial Submenu

\* = Factory Default

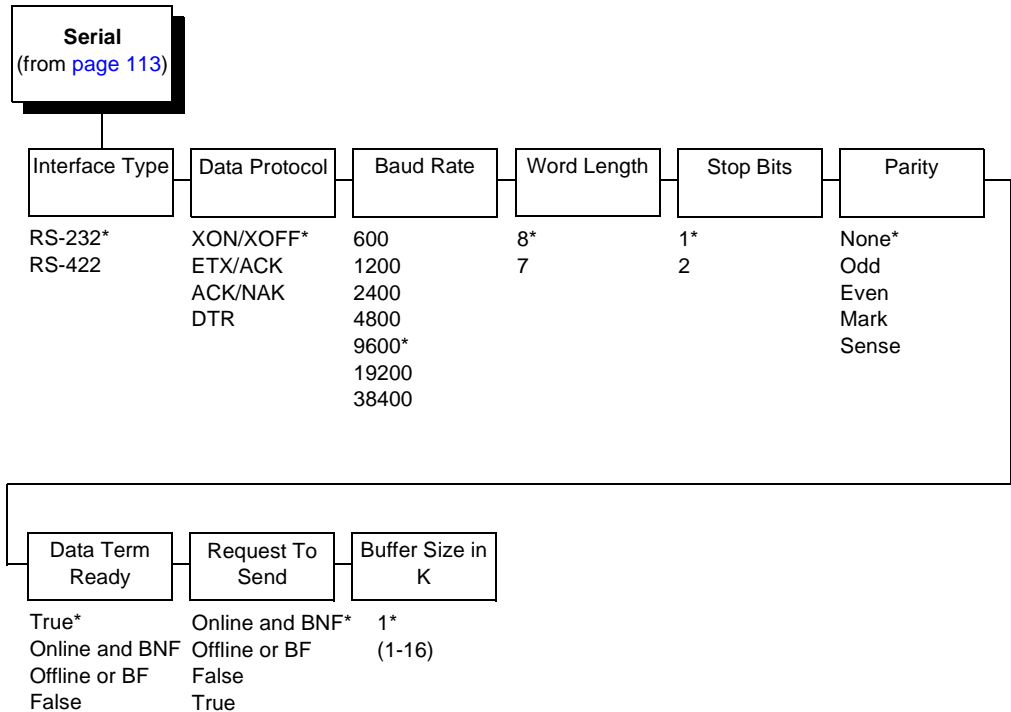

## Interface Type

This parameter allows you to select either the RS-232 or RS-422 serial port interface.

## Data Protocol

You can select one of the following serial interface protocols to meet the host interface requirements.

- **XON / XOFF.** The printer controls the flow of communication from the host by turning the transmission on and off. In some situations, such as when the buffer is full or the timing of signals is too slow or too fast, the printer will tell the host to stop transmission by sending an XOFF character. An XOFF character is sent when the number of empty bytes in the buffer is less than or equal to 25 percent of the buffer size. If the host keeps sending data after an XOFF is sent, the printer firmware will continue to send an XOFF for every 16 characters received. When cleared, the printer will resume receiving data (XON). The data does not have any End of Text codes; XON / XOFF is a non-block protocol.
- **ETX / ACK.** End of Text / Acknowledge. The host controls the flow of communication to the printer by sending a block of data and ending the block with an End of Text (ETX) signal. When the printer receives the ETX signal, it will acknowledge the ETX, thereby acknowledging it has received the entire block of data.
- **ACK / NAK.** ACK means acknowledge; the device acknowledges it has accepted a transmission. NAK means negative acknowledge; the device did not receive the transmission.
- **DTR.** The printer controls the data flow by sending this hardware signal to the host. If there is enough room in the printer buffer, the printer will send a high signal; if the buffer is full the printer will send a low signal. DTR tells the host if it is safe to send more data. (If the host sends data during an unsafe condition, data will be lost.) DTR is not available when RS-422 is selected.

### Baud Rate

Sets the baud rate of the serial interface in the printer. Baud rate is the speed at which serial data is transferred between the host computer and the printer. The choices for the RS-232 and RS-422 interfaces are 600, 1200, 2400, 4800, 9600, 19200, and 38400 Baud.

**NOTE:** If you select a baud rate that is greater than 19200, you may need to use RS-422 to prevent data loss. You also may need to increase the Buffer Size in K parameter from the default (1 Kbyte) to improve performance.

### Word Length

Sets the length of the serial data word. The length of the data word can be set to 7 or 8 bits, and must match the corresponding data bits setting in the host computer.

### Stop Bits

Sets the number of stop bits in the serial data word. Either one or two stop bits can be selected. The setting must match the corresponding stop bit setting in the host computer.

### Parity

Set for odd parity, even parity, mark, sense, or no parity. The setting must match the corresponding parity setting in the host computer.

### Data Terminal Ready

This configuration is part of hardware flow control and determines when the Data Terminal Ready (DTR) signal is generated. This signal indicates if the printer is ready to receive data.

- **True.** Continuously asserts the DTR signal.
- **On-Line and BNF (buffer not full).** Asserts the DTR signal when the printer is online and the internal serial buffer is not full.
- **Off-Line or BF (buffer full).** Asserts the DTR signal when the printer is offline or the internal serial buffer is full.
- **False.** Never asserts the DTR signal.

### Request to Send

This configuration is part of hardware flow control and determines when the Request to Send (RTS) signal is generated. This signal indicates whether or not the printer is ready to receive data.

- **On-Line and BNF.** Asserts the RTS signal when the printer is online and the internal serial buffer is not full.
- **Off-Line or BF.** Asserts the RTS signal when the printer is offline or the internal serial buffer is full.
- **False.** Never asserts the RTS signal.
- **True.** Continuously asserts the RTS signal.

### Buffer Size in K

This option configures the amount of memory allocated for the serial port buffer. You may specify between 1 and 16 Kbytes, in 1-Kbyte increments.

**NOTE:** If you select a baud rate that is 19200 or greater, you may need to increase the Buffer Size in K parameter from the default to 16 Kbytes to improve performance.

## IEEE 1284 Parallel (Bidirectional) Submenu

\* = Factory Default

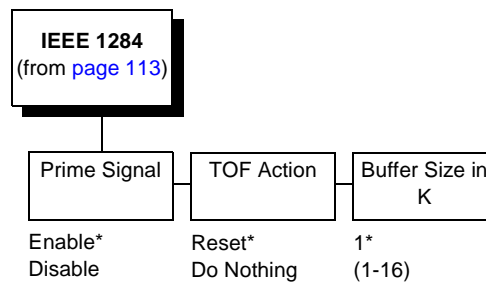

The IEEE<sup>®</sup> 1284 interface supports bidirectional communication. Configuration of this interface is controlled from the host.

### Prime Signal

- **Enable.** The parallel port will perform a warm start (reboot) if the host asserts the Prime Signal.
- **Disable.** The parallel port will not perform a warm start (reboot) if the host asserts the Prime Signal.

### TOF Action

- **Reset.** A form feed is performed before a warm start when the prime signal is asserted from the host. This setting is used only if the Prime Signal parameter is enabled.
- **Do Nothing.** Nothing occurs before a warm start when the prime signal is asserted from the host.

### Buffer Size in K

This option configures the amount of memory allocated for the IEEE 1284 parallel port buffer. You can specify between 1 and 16 Kbytes, in 1-Kbyte increments.



## Ethernet Submenu

---

\* = Factory Default

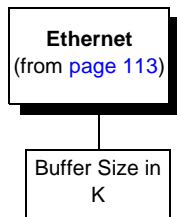

1\*  
(1-16)

The Ethernet interface allows you to locate the printer on a LAN rather than attach the host directly into the printer. The detailed configuration of this option is given in the *PrintNet User's Manual*.

### Buffer Size in K

This option configures the amount of memory allocated for the Ethernet buffer. You can specify between 1 and 16 Kbytes, in 1-Kbyte increments.

## ETHERNET PARAMETERS

---

### Menu

---

\* = Factory Default

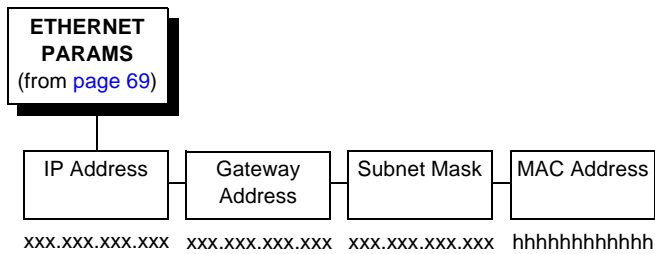

The ETHERNET PARAMS menu enables you to configure your printer to communicate on a network.

For information on assigning the IP Address, Gateway Address, Subnet Mask and MAC Address, refer to the *PrintNet User's Manual*.

## PRINTER CONTROL

\* = Factory Default

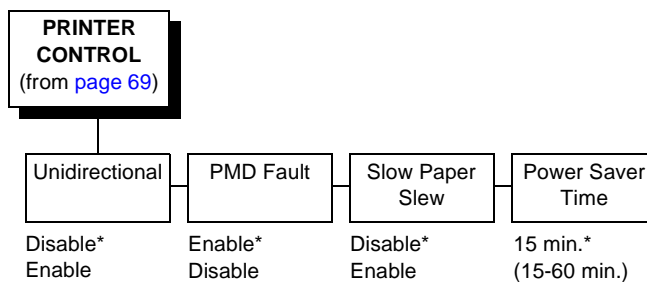

### Unidirectional

The Unidirectional feature affects both print quality and printing speed. By setting this feature, you can configure the printer to print in both directions of the shuttle sweep (bidirectional), or to print in one direction only (unidirectional).

- **Disable.** The printer will print all data in both directions of the shuttle sweep (bidirectional printing). This choice produces higher printing speed.
- **Enable.** The printer will print all data in only one direction of the shuttle sweep (unidirectional printing). Although enabling this feature reduces print speed, it enhances the vertical alignment of dots and produces cleaner, sharper bar codes and text.

### PMD (Paper Motion Detection) Fault

- **Enable.** In the event of a paper jam, an audible alarm beeps, “CLEAR PAPER JAM” appears on the message display, and the printer stops printing.
- **Disable.** You should disable PMD only if special paper requires it.

**CAUTION** Once PMD is disabled, paper motion is not monitored. If a paper jam occurs, the printer ignores the condition and continues to print, possibly causing damage to the printer.

### Slow Paper Slew

- **Disable.** The printer will slew and stack paper at maximum speed.
- **Enable.** Causes the paper to stack at a slower rate. This ensures that certain forms will stack neatly.

### Power Saver Time

Power Saver is also referred to as ENERGY STAR® Office Equipment Program. The Power Saver feature places the printer in “sleep mode” when the printer has not been used for a specified number of minutes. In sleep mode the printer is in low-energy idle state, all fans and higher voltages are off, and only +5Vdc logical circuits are active.

You can designate the number of minutes after which the printer will go into sleep mode. The range time is 15 to 60 minutes. Fifteen minutes is the default.

Pressing any key on the control panel or sending a print job to the printer will turn off sleep mode.

## DIAGNOSTICS

### DIAGNOSTICS (from [page 69](#))

\* = Factory Default  
<sup>1</sup> If Ethernet adapter is present.

Printer Tests	Test Width	Paper Out Dots	System Memory	Print Statistics
Shift Recycle* All E's E's + TOF All H's All Underlines All Black Shuttle Slow Shuttle Fast Shuttle Only Phase Printer 217* (500 lpm) 123* (1000 lpm) 62* (1500 lpm) 1 to 2000 Paperout Adj. Burnin Test Print Error Log Clear Error Log E-net Test Page <sup>1</sup>	Full Width* 80 columns	40 dots* (4-76)	X Megabytes	On: X.X hrs. Print: X.X hrs. Print Strokes Print Lines 11 inch Pages

### Printer Tests

These tests are used to check the print quality and operation of the printer.

**NOTE:** Your authorized service representative will typically run the tests. They are described in more detail in the *Maintenance Manual*.

- **Shift Recycle.** A sliding alphanumeric pattern which identifies missing or malformed characters, improper vertical alignment, or vertical compression.
- **All E's.** A pattern of all uppercase E's which identifies missing characters, misplaced dots, smeared characters, improper phasing problems, or light/dark character variations.

## Chapter 4 DIAGNOSTICS

---

- **E's + TOF.** A pattern of all E's followed by a form feed to the next page top-of-form, which identifies paper motion or feeding problems.
- **All H's.** A pattern of all uppercase H's used to detect missing characters, misplaced dots, smeared characters, or improper phasing.
- **All Underlines.** An underline pattern useful for identifying hammer bank misalignment.
- **All Black.** A condition where all dot positions are printed, creating a solid black band.
- **Shuttle Slow.** Verifies proper operation by exercising shuttle and ribbon motion at low speed.
- **Shuttle Fast.** Verifies proper operation by exercising shuttle and ribbon motion at fast speed.
- **Shuttle Only.** Exercises only the shuttle at fast speed.
- **Phase Printer.** Checks for wavy print. The initial phase value is set in the factory. Run the test and check the quality. (The phase value prints on the left margin.) If the print looks too wavy, change the Phase Value parameter while the test is running. While the phase printer test runs, press the DOWN key. To change the value, press the PREV or NEXT key until the desired value displays and then press ENTER.
- **Paperout Adjust.** Verifies the current Paper Out Dots setting, which determines where the last line of text will print when there is a paper out condition. Setting this parameter correctly prevents printing on the platen.
- **Burnin Test.** Reserved for factory use.
- **Print Error Log.** Prints the current log of errors. Most non-routine faults (ribbon stall, voltage faults) are stored in the error log.
- **Clear Error Log.** Clears entries in the error log.
- **E-net Test Page.** Prints the Ethernet statistics stored on the Ethernet adapter (if present).

### Test Width

Set this parameter to run the self-tests at full width or 80 columns.

### Paper Out Dots

This parameter is used to adjust the paper out distance from the perforation; you can specify where the last line on the page will print when there is a paper out condition. Setting this parameter correctly prevents printing on the platen.

**CAUTION** Only authorized service representatives should set this parameter.

### System Memory

Displays the amount of RAM installed.

### Print Statistics

You can view various printer statistics and refer to them for preventive maintenance purposes. Printer statistics accumulate continuously; they do not reset when you turn off the printer. All of the printer statistics are set to zero at the factory after burn-in testing.

- **On.** The cumulative time in hours the printer has been powered on. The range is 0 to 30,000 hours.
- **Print.** The cumulative time in hours the printer has actually been printing. The range is 0 to 30,000 hours.
- **Print Strokes.** The cumulative number of back-and-forth shuttle strokes the printer has printed during normal printer operation. The range is 0 to 2,147,483,647 shuttle strokes.
- **Print Lines.** The cumulative number of lines the printer has printed. The range is 0 to 2,147,483,647 print lines.
- **11 inch Pages.** The cumulative number of pages the printer has printed. The range in print pages is 0 to 2,147,483,647 total inches of paper movement divided by 11.

## RIBBONMINDER

---

RibbonMinder™ is a user-definable software feature which notifies the user when a ribbon should be changed. It does this by monitoring ink consumption and alerts you when the print quality falls below a level you designate. This is especially important if you are printing bar codes to be scanned.

```
ON LINE    100%
<printer emulation>
```

As printing continues, the percentage of usable ink in the ribbon decreases.

```
ON LINE    74%
<printer emulation>
```

Ribbon ink being consumed

```
ON LINE    8%
<printer emulation>
```

Ribbon life approaching end

When 0% usable ink appears, the printer is typically configured to stop printing and display the following message:

```
RIBBON INK OUT
CHANGE RIBBON
```

**NOTE:** Once you have set up options for RibbonMinder, it works without attention. When you begin printing with RibbonMinder enabled, the message display shows a ribbon life value of 100%. The ribbon life decreases as the ink is consumed.



\* = Factory Default

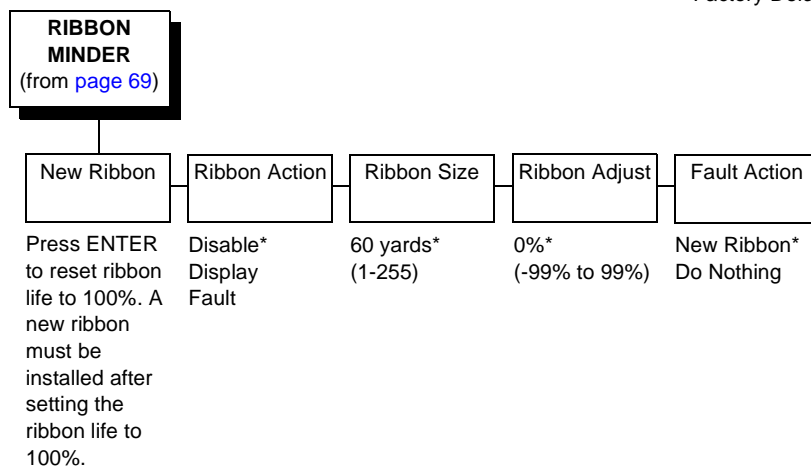

## New Ribbon

Whenever you install a new ribbon, you must reset the ribbon life to 100%.

Once you install the new ribbon, work your way through the configuration menus until “New Ribbon” appears on the LCD. Press the ENTER key to reset the ribbon life to 100%.

## Ribbon Action

- **Disable.** Removes the ink consumption display. RibbonMinder will continue to monitor how much ink is left in the ribbon.
- **Display.** Activates the RibbonMinder ink consumption display. Allows you to continually monitor the percentage of ink left in the ribbon.
- **Fault.** Activates a fault message when the display reaches 0%.

### Ribbon Size

The standard ribbon size is 60 yards for the pedestal model and 100 yards for the cabinet model. These are the factory default settings. You can use the Ribbon Size option to specify the ribbon length in one-yard increments, with a maximum of 255 yards.

### Ribbon Adjust

Adjust the number of pages printed before the display reaches 0%. If the ribbon normally prints 1000 pages before reaching 0%, configuring the Ribbon Adjust to 20% will print 200 more pages than normal before reaching 0%. A Ribbon Adjust setting of -20% will cause the display to reach 0% after 200 fewer pages than normal. The setting can range from -99% through 99%.

### Fault Action

- **New Ribbon.** Changing the ribbon while in the RIBBON INK OUT / CHANGE RIBBON fault mode will reset the ribbon life to 100%, just as if the New Ribbon menu option was executed.
- **Do Nothing.** The ribbon life may only be reset through the New Ribbon menu option.

### RibbonMinder Fault

When the RIBBON INK OUT / CHANGE RIBBON fault message appears on the LCD, press the CLEAR key to remove the fault message, then follow the “Replacing the Ribbon” procedure on [page 57](#). If you need to complete a current print job before replacing the ribbon, press ON LINE. This allows the printer to continue printing for an additional two minutes. After the two-minute period has elapsed, the fault will reoccur if the Ribbon Action parameter remains set on Fault. If Ribbon Action is changed to Disable or Display within the two-minute period, the fault will not recur; disable RibbonMinder if you do not want to change the ribbon at this time. The fault message will reappear once the function is enabled again, and the printer status indicator will flash until the ribbon is changed.

---

# 5

## *Interfaces*

---

### Overview

This chapter describes the host interfaces provided with the printer. The printer interface is the point where the data line from the host computer plugs into the printer. The interface processes all communications signals and data to and from the host computer.

This chapter describes the interfaces provided with the printer.

**Standard Host Interfaces:**

- IEEE 1284 parallel bidirectional
- High Speed Serial Port (RS-232/RS-422)

**Optional Host Interfaces:**

- Dataproducts Long Line
- Ethernet 10Base-T
- Ethernet 10Base2

In addition to descriptions for the multi-line interfaces, this chapter also provides instructions for configuration of terminating resistors for the parallel interfaces.

## Dataproducts Long Line Interface

**Table 3. Dataproducts Long Line Interface Connector Pin Assignments  
(with a 50-pin AMP HDH-20 Data Cable Connector)**

Input Signals		Output Signals		Miscellaneous	
Signal	Pin	Signal	Pin	Signal	Pin
DATA LINE 1	19	READY	22	CABLE VERIFY	45, 46
Return	3	Return	6		
DATA LINE 2	20	ONLINE	21	GROUND	39
Return	4	Return	5		
DATA LINE 3	1	DEMAND/DATA REQ.	23	TEST	12
Return	2	Return	7		
DATA LINE 4	41	PARITY ERROR	27		
Return	40	Return	11		
DATA LINE 5	34				
Return	18				
DATA LINE 6	43				
Return	42				
DATA LINE 7	36				
Return	35				
DATA LINE 8	28				
Return	44				
DATA STROBE	38				
Return	37				
PAPER INSTRUCTION	30				
Return	14				
BUFFER CLEAR	31				
Return	15				

NOTE: Pins not listed are not connected.

The length of the data cable from the host computer to the printer must not exceed 492 feet (150 meters).

### Dataproducts Long Line Interface Signals

---

Dataproducts-compatible interface signals between the host computer and the printer are defined as follows:

**Data Lines 1 through 8.** Provides eight standard or inverted levels from the host that specify character data, plot data, or a control code. Data Line 8 allows access to the extended ASCII character set. You can enable or disable this line via the Data Bit 8 parameter on the Dataproducts submenu (see [page 114](#)).

**Data Strobe.** Carries a high true pulse from the host when data is ready. The data strobe remains high until the Data Request line goes false. The active edge of the strobe signal can be configured as leading, middle (default), or trailing.

**Paper Instruction (PI).** Carries a DVFU signal from the host with the same timing and polarity as the data lines.

**Ready.** Carries a high true signal from the printer when AC power and DC voltages are present, paper is loaded properly, and the printer is not in a check condition.

**Online.** Carries a high true signal from the printer when the Ready Line is true and the ON LINE key on the control panel has been pressed. When the printer is in online mode, it may accept data from the host.

**Demand/Data Request.** Carries a high true signal from the printer when the printer is ready to accept character data from the host. This signal changes to false shortly after the leading edge of the data strobe signal.

**Cable Verify.** Two pins on the interface connector are jumpered together to allow the user to verify proper installation of the interface connector.

**Buffer Clear.** A high true level from the host to indicate the printer should perform a reboot.

**Test.** This signal is connected to +5 volts through a 470 ohm resistor.

**Parity Error.** Always carries a low false signal from the printer indicating there is no parity error.

## IEEE 1284 Parallel Interface

---

The 1284 supports three operating modes, which are determined by negotiation between the printer and the host.

### Compatibility Mode

---

This mode provides compatibility with Centronics<sup>®</sup>-like host I/O. Data is transferred from the host to the printer in 8-bit bytes over the data lines.

Compatibility Mode can be combined with Nibble and Byte Modes to provide bidirectional communication.

### Nibble Mode

---

Eight bits equals one byte. When a byte of data is sent to the printer, the eight bits are sent over eight data lines.

Some devices cannot send data over their eight data lines. To bypass this, the 1284 permits data to be sent as half a byte over four status lines. (Half a byte equals one nibble.) Two sequential four-bit nibbles are sent over the lines.

Data is transferred from printer to host in four-bit nibbles over the status lines, and the host controls the transmission.

### Byte Mode

---

The printer and host send data to each other along eight data lines (one bit per line).

If bidirectional communication is supported by the printer and the host, the host will take control of the data transfer.

## Signals

Table 4 lists each of the signals associated with the corresponding pins on the 1284 interface. Descriptions of the signals follow.

**Table 4. 1284 Signals**

Pin	Source of Data	Type of Mode		
		Compatible	Nibble	Byte
1	Host	nStrobe	HostClk	Host/Clk
2	Host/Printer	Data 1 (LSB)		
3	Host/Printer	Data 2		
4	Host/Printer	Data 3		
5	Host/Printer	Data 4		
6	Host/Printer	Data 5		
7	Host/Printer	Data 6		
8	Host/Printer	Data 7		
9	Host/Printer	Data 8 (MSB)		
10	Printer	nAck	PtrClk	PtrClk
11	Printer	Busy	PtrBusy	PtrBusy
12	Printer	PError	AckDataReq	AckDataReq
13	Printer	Select	Xflag	Xflag
14	Host	nAutoFd	Host Busy	HostAck
15		Not Defined		
16		Logic Grid		
17		Chassis Grid		
18	Printer	Peripheral Logic High		

**Chapter 5 IEEE 1284 Parallel Interface**

**Table 4. 1284 Signals (continued)**

Pin	Source of Data	Type of Mode		
		Compatible	Nibble	Byte
19		Signal Ground (nStrobe)		
20		Signal Ground (Data 1)		
21		Signal Ground (Data 2)		
22		Signal Ground (Data 3)		
23		Signal Ground (Data 4)		
24		Signal Ground (Data 5)		
25		Signal Ground (Data 6)		
26		Signal Ground (Data 7)		
27		Signal Ground (Data 8)		
28		Signal Ground (PErr, Select, nAck)		
29		Signal Ground (Busy, nFault)		
30		Signal Ground (nAutoFd, nSelectIn, nInit)		
31	Host	nInit		
32	Printer	NFault	nDataAvail	aDataAvail
33		Not Defined		
34		Not Defined		
35		Not Defined		
36	Host	nSelectIn	1284 Active	1284 Active

**NOTE:** The length of the data cable from the host computer to the printer should not exceed 10 meters (32 feet).



## Signals

---

**Host Clock / nWrite.** Driven by host. Data transferred from host to printer. When printer sends data, two types are available. If Nibble Mode, signal is set high. If Byte Mode, signal is set low.

**Data 1 through Data 8.** These pins are host-driven in Compatibility Mode and bidirectional in Byte Mode. They are not used in Nibble Mode. Data 1 is the least significant bit; Data 8 is the most significant bit.

**Printer Clock / Peripheral Clock / Interrupt.** Driven by the printer. A signal from the printer indicating the character or function code has been received and the printer is ready for the next data transfer.

**Printer Busy / Peripheral Acknowledge / nWait.** Driven by the printer. Indicates the printer cannot receive data. (Data bits 4 and 8 in Nibble Mode.)

**Acknowledge Data Request / nAcknowledge Reverse.** Driven by the printer. Indicates the printer is in a fault condition. (Data bits 3 and 7 in Nibble Mode.)

**Xflag.** Driven by the printer. A high true level indicating the printer is ready for data transfer and the printer is on-line. (Data bits 2 and 6 in Nibble Mode.)

**Host Busy / Host Acknowledge / NDStrobe.** Driven by the host. Activates auto-line feed mode.

**Peripheral Logic High.** Driven by the printer. When the line is high, the printer indicates all of its signals are in a valid state. When the line is low, the printer indicates its power is off or its signals are in an invalid state.

**nReverse Request.** Driven by the host. Resets the interface and forces a return to Compatibility Mode idle phase.

**nData Available / nPeripheral Request.** Driven by the printer. Indicates the printer has encountered an error. (Data bits 1 and 5 in Nibble Mode.)

**1284 Active / nAStrobe.** Driven by the host. A peripheral device is selected.

**Host Logic High**—Driven by the host. When set to high, the host indicates all of its signals are in a valid state. When set to low, the host indicates its power is off or its signals are in an invalid state.

**nInit** —Resets init interface from the host.

## Terminating Resistor Configurations

The factory equips the printer with several resistors that are used for parallel interface configurations and are suitable for most applications. These 470 ohm pull-up and 1K ohm pull-down terminating resistors are located at RP1 and RP2, shown in [Figure 13](#).

If the values of these terminating resistors are not compatible with the particular interface driver requirements of your host computer, you may need to install resistors with different pull-up and pull-down values.

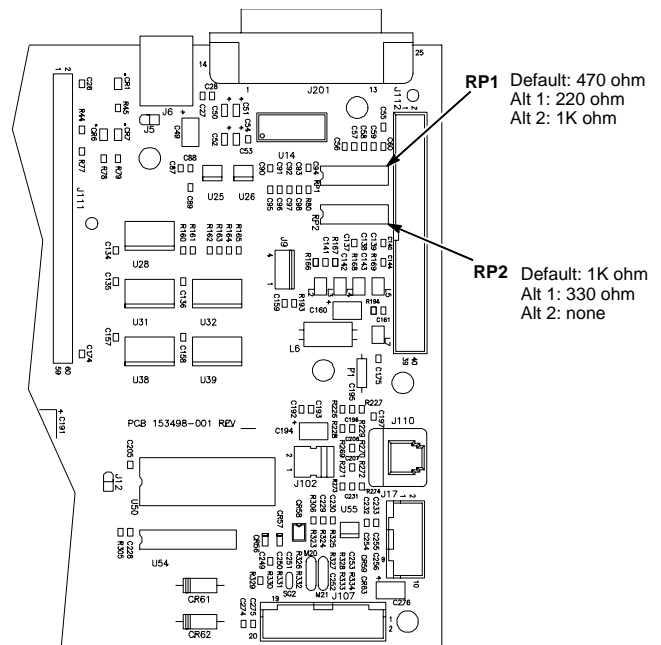

Figure 13. Resistor Locations

## Terminating Resistor Configurations

---

The shipping kit for this printer includes 220 ohm pull-up and 330 ohm pull-down alternate terminating resistors. If you install the 220 ohm pull-up resistor, you must also install the 330 ohm pull-down resistor. [Table 5](#) lists the three terminating resistor configurations you can install:

**Table 5. Terminating Resistor Configurations**

Configuration	Pull-Up (RP1)	Pull-Down (RP2)
Factory Default	470 ohm	1K ohm
Alternate 1	220 ohm	330 ohm
Alternate 2	1K ohm	none

### Removal and Installation

The procedure for removing and installing terminating resistors is provided in your *Maintenance Manual*.

**IMPORTANT** This is an involved maintenance procedure; only a trained technician should perform this procedure.

## RS-232 and RS-422 Serial Interfaces

**NOTE:** The RS-232 and RS-422 serial interface circuit characteristics are compatible with the Electronic Industry Association Specifications EIA<sup>®</sup>-232-E and EIA-422-B.

The RS-232 and RS-422 serial interfaces enable the printer to operate with bit serial devices that are compatible with an RS-232 controller. The input serial data transfer rate (in baud) is selectable from the printer's control panel. Baud rates of 600, 1200, 2400, 4800, 9600, 19200, and 38400 baud rates are available.

**NOTE:** If you select a baud rate that is greater than 19200, you may need to use RS-422 to prevent data loss. You may also need to increase the Buffer Size in K parameter from the default (1 Kbyte), to improve performance.

The length of the data cable from the host computer to the printer must not exceed 50 feet (15 meters) for RS-232 or 4000 feet (1220 meters) for RS-422. (A copper conductor, twisted-pair telephone cable with a shunt capacitance of 16 pF/foot [52.5 pF/meter] terminated in a 100 ohm resistive load must be used for the RS-422.

### RS-232

Table 6. RS-232 Serial Interface Connector Pin Assignments

Input Signals		Output Signals		Miscellaneous	
Signal	Pin	Signal	Pin	Signal	Pin
Receive Data (RD)	3	Transmit Data (TD)	2	Chassis Ground	1
Clear To Send (CTS)	5	Request To Send (RTS)	4	Signal Ground	7
Data Set Ready (DSR)	6	Data Terminal Ready (DTR)	20		
Data Carrier Detect (DCD)	8				

**Received Data (RD).** Serial data stream to the printer.

**Transmitted Data (TD).** Serial data stream from the printer for transmitting status and control information to the host. Subject to protocol selection.

**Request To Send (RTS).** Control signal from the printer. Subject to configuration.

**Clear To Send (CTS).** Status signal to the printer indicating the host is ready to receive data/status signals from the printer.

**Data Set Ready (DSR).** Status signal to the printer indicating the host is in a ready condition.

**Data Carrier Detect (DCD).** Status signal to the printer. The ON condition is required for the printer to receive data.

**Data Terminal Ready (DTR).** Control signal from the printer. Subject to configuration.)

## RS-422

**Table 7. RS-422 Serial Interface Connector Pin Assignments**

Input Signals		Output Signals		Miscellaneous	
Signal	Pin	Signal	Pin	Signal	Pin
- Receive Data (-RD)	15	- Transmit Data (-TD)	19	Chassis Ground	1
+ Receive Data (+RD)	17	+ Transmit Data (+TD)	25	Signal Ground	7

**+RD, -RD**—Serial data stream differentially received by printer.

**+TD, -TD**—Differentially driven serial data stream for transmitting status and control information to the host. Subject to protocol selection.

**NOTE:**  $\pm$ RD and  $\pm$ TD form signal and return paths of a differential line signal.

## Host System Configuration

---

The Compaq series of line matrix printers do not support the Tandem Asynchronous Protocol (TAP), or Transparent Tandem Asynchronous Protocol (T-TAP).

### Dataproducts Long Lines Parallel Interface

---

SYSGEN - Use the 5518 macro name. For a complete list of attributes for parallel printers, refer to the System Generation manual for Terminals and Printers (P/N 107875).

**NOTE:** The EIO Timeout parameter may need to be configured depending on the speed of the printer.

### TCP/IP LAN Configuration

---

In order to configure a network printer on a Compaq system, a file in \$system.system called "FASTCNFG" must be created. The following is an example entry in FASTCNFG for the 5525B/31/32 printer:

```
DEVICE           = <$PRINTER NAME>
CONTYPE          = TCP/IP
PROTOCOL         = MICROPLEX
ADDRESS          = <IP ADDRESS>
QUEUE_NAME       = NAME OF PRINT QUEUE>
HOSTNAME         = NAME OF SERVER
PORT             = 4400
BLOCK            = 1024
TIMEOUT          = <ADJUST TO AVOID TIMEOUTS> (i.e. 4000)
POLLNUM          = 100
IDLETIMEOUT      = 60
TCP/IP-A         = <PROCESS NAME>
ONLINEMODE       = NO/YES (default is NO)
```

**NOTE:** In order to configure the printer with the Internal Ethernet Adapter from the front panel, please refer to [page 144](#).

## Serial Configuration

SYSGEN - Use the ASYNC\_PRT macro name.  
 CHAR8 SYSGEN modifier is highly recommended.

SPOOLCOM - DEVTYPE should be blank.

**NOTE:** DEVSUBTYPE SYSGEN modifier must be set to 32.

ETX/ACK - Protocol is not recommended.

CURRENT LOOP - Supported only when using a Current Loop to RS232 adapter, TCL2 (P/N 50069). Flow control is provide by XON/XOFF only. On the printer set the DTR option to True. Note that any other setting can cause Framing and Parity errors.

RS232 - Supports both XON/XOFF and DTR. Both XON/XOFF and DTR are used for flow control only, and do not provide any status back to the host other than printer ready, or not ready. For a complete list of attributes for serial printers, refer to the System Generation manual for Terminals and Printers (P/N 107875).

RS422 - Supported by both Compaq hosts and printers. However, the RS422 cables provided by Compaq are not suitable for use with these printers. Thus, a custom cable must be used if you are using the RS422 protocol. (See [Figure 14](#) for pin assignments for a typical RS422 connection.) Flow control is provided by XON/XOFF only.

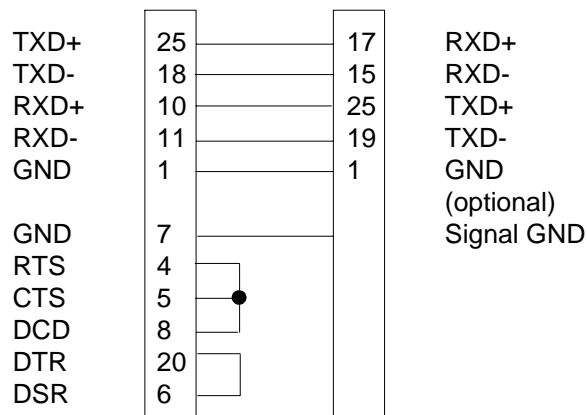

Figure 14. RS-422 Pin Assignments

## Chapter 5 Internal Ethernet Adapter Configuration







For a complete list of attributes for nonstandard serial printers, refer to the System Generation manual for Terminals and Printers (P/N 107875).

### Internal Ethernet Adapter Configuration

There are two ways that the Internal Ethernet Adapter can be configured, either through the front panel or by using dynamic processes such as Bootp and Rarp. The IP Address, Subnet Mask, and the Gateway Address can all be set from the panel.

#### Ethernet Configuration Using the Printer Front Panel



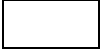







Table 8. Ethernet Configuration

Step	Key	Result	Notes
1.	Make sure the printer is on. Raise the printer cover.		
2.	ON LINE 	OFFLINE CONFIG. CONTROL	
3.	 + 	ENTER SWITCH UNLOCKED	Allows you to make configuration changes.
		OFFLINE CONFIG. CONTROL	
4.	 UNTIL	OFFLINE ETHERNET PARAMS	
5.		ETHERNET PARAMS IP Address	
6.		IP Address www.xxx.yyy.zzz	
7.		www.xxx.yyy.zzz www	Selecting www to change.



## Ethernet Configuration Using the Printer Front Panel

**Table 8. Ethernet Configuration (continued)**

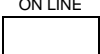
Step	Key	Result	Notes
8.		<div style="border: 1px solid black; padding: 2px;">www*</div>	Asterisk (*) indicates this choice is active.
9.	 OR 	<div style="border: 1px solid black; padding: 2px;">www</div>	Scroll through to change numbers.
10.	ENTER 	<div style="border: 1px solid black; padding: 2px;">www*</div>	An asterisk (*) appears next to your choice. This selection is active.
11.		<div style="border: 1px solid black; padding: 2px;">www.xxx.yyy.zzz www</div>	
12.		<div style="border: 1px solid black; padding: 2px;">www.xxx.yyy.zzz xxx</div>	Selecting xxx to change.
13.	Repeat steps 8 through 11 to change the value for xxx.		
14.		<div style="border: 1px solid black; padding: 2px;">www.xxx.yyy.zzz yyy</div>	Selecting yyy to change.
15.	Repeat steps 8 through 11 to change the value for yyy.		
16.		<div style="border: 1px solid black; padding: 2px;">www.xxx.yyy.zzz zzz</div>	Selecting zzz to change.
17.	Repeat steps 8 through 11 to change the value for zzz.		
18.	ENTER 	<div style="border: 1px solid black; padding: 2px;">IP Address www.xxx.yyy.zzz</div>	The IP Address is stored in NVRAM.
19.	To select the Gateway Address and Subnet Mask, simply repeat the steps above.		
20.	 + 	<div style="border: 1px solid black; padding: 2px;">ENTER SWITCH LOCKED</div>	Locks the ENTER key.
21.	ON LINE 	<div style="border: 1px solid black; padding: 2px;">ONLINE</div>	
22.	Close the printer cover. The printer is ready for operation.		

## Configuring the Internal Ethernet Adapter for TCP/IP

---

The Compaq line matrix printer has an Internal Ethernet Adapter installed and will be referred to as such for the remainder of the chapter. This section is exclusively devoted to the configuration of the Internal Ethernet Adapter.

If you are setting up the Internal Ethernet Adapter in a TCP/IP environment, this section will help you in all aspects of the setup process. The provided host software is introduced and steps are given for configuring the Internal Ethernet Adapter for communications over the network and for printing. Since TCP/IP encompasses a wide variety of system types, the most common are covered in detail to help get you printing in a TCP/IP environment.

### Host Software

---

The TCP/IP software provided includes two setup programs, source code, interface files, and various printing-related programs such as:

- **onlcr** for carriage return insertion
- **banner** for banner page generation
- **chr** for echoing ASCII characters and strings to standard output
- **npstramble** for print job scrambling
- **npd** for bidirectional communication when printing
- **npwrite** for direct socket printing

**chr** is the only mandatory binary when using one of the interface scrips for printing. The extra processing binaries (**onlcr**, **banner**) can be configured from the host, or they can each be set on the Internal Ethernet Adapter, alleviating the host of these extra tasks.

**NOTE:** To be utilized on a host, they must be used in conjunction with an interface file.

### Compiling Host Software

---

Some compilation may be needed before adding setups to your host unless you have Sun<sup>®</sup> OS 4.1.x, Solaris<sup>®</sup> 2.x, or SCO UNIX<sup>®</sup>. Pre-compiled binaries are provided for these. **npconfig** can be used to do the compilation, or you can try and compile each program independently. For the npconfig method perform the following steps:

1. Select **Detailed Configuration Options...** from the **npconfig** Main Menu.
2. Select **Manage Host Software...** from the Options Submenu.
3. Select **Compile Host Software** and answer the prompts until compiled.

For more information on the provided host software, see the following subsections.

#### **ezsetup and npconfig**

**ezsetup** and **npconfig** are the two installation programs provided. **ezsetup** is used for a quick, simple setup and **npconfig** is used for more detailed configuration, or for maintenance and troubleshooting the Print Server. Both programs help to configure your Internal Ethernet Adapter and direct print jobs to it.

**ezsetup** provides two choices; they are the same as the first two choices of **npconfig**'s Main Menu. Within minutes, you will have configured the Internal Ethernet Adapter so it can be recognized on the network and your host will be able to successfully send print jobs to it.

If you would like to spend more time manipulating the extra capabilities of the Print Server and your host's configuration, use **npconfig**. It can be used to configure a print destination on your host and as a Print Server management utility allowing you to monitor, change, and troubleshoot the unit.

## Chapter 5 Configuring the Internal Ethernet Adapter for TCP/IP

---

Table 9. npconfig/ezsetup Main Menu

Option	Description
Configure New Unit	Add an Internal Ethernet Adapter Print Server to your network. This option provides for: IP name, IP address, hardware address, netmask, and for root and guest passwords ( <b>ezsetup</b> also).
Configure Host Setup	Configure a print destination on the host, including communication mechanism and processing options ( <b>ezsetup</b> also).
Detailed Configuration Options	See <a href="#">Table 10</a> , below.
Check Current Print Server Status	Display current status of a Print Server and I/O port.
Cancel a print Job in the Print Server	Display current status of a Print Server, current print jobs within it, and a prompt for a print job to be canceled.

**Table 10. npconfig Detailed Configuration Options Submenu**

Option	Description
Select Print Server	Select the Print Server you want to configure.
Configure Print Server Destination	Configure the Internal Ethernet Adapter destination settings: name, I/O port, model, logpath, state, and service(s).
Configure Print Server's Models	Configure the Internal Ethernet Adapter model setting: name, type, banner, page, carriage return insertion ( <b>onlcr</b> ), tab expansion ( <b>xtab</b> ), descrambling, ASCII to PostScript <sup>®</sup> conversion ( <b>a2ps</b> ), and header and trailer strings.
Configure Print Server's I/O Ports	Configure the Internal Ethernet Adapter port settings: state, timeout, hand-shaking, parity, and speed.
Configure Print Server's Log Paths	Configure the Internal Ethernet Adapter logpath settings: name, type, and port.
Configure Print Server's User's	Add and remove users. Change user passwords and user types.
Configure Print Server's Novell <sup>®</sup> Options	Configure and list the Internal Ethernet Adapter Novell settings: name, frame type, and PSERVER password. List Internal Ethernet Adapter PSERVER and RPRINTER configuration.
Configure Print Server's Network Options	Configure and list the Internal Ethernet Adapter IP address, netmask, routing entries, frame type, and RARP and BOOTP setting. Restores unit to default settings. List all network related settings.
Configure Print Server's System Information	Display and modify system information of a Print Server: Internal Ethernet Adapter name, contact name, location string, log details, descramble key, license key, and module(s).

## Chapter 5 Configuring the Internal Ethernet Adapter for TCP/IP

---

**Table 10. npconfig Detailed Configuration Options Submenu (continued)**

Option	Description
Configure Print Server's Permanent Settings	For Print Server settings, query status and store changes to/from EEPROM and factory defaults.
Manage Host Software	Install manual pages, compile source code, and install binaries and scripts provided on the host software media.
Debug Print Server	Use Internal Ethernet Adapter debug commands. Start I/O port tests.
Remote Host Security	Specify TCP hosts/networks which communicate with the Internal Ethernet Adapter.

## Computer-aided Configuration with ezsetup or npconfig

---

When the Internal Ethernet Adapter is initially installed on a TCP/IP network, you are unable to communicate with it since its network parameters are not initialized. During configuration, the following parameters are initialized and saved in EEPROM:

- IP address (mandatory)
- netmask or sub-netmask (mandatory)
- **root** user password (recommended for security)
- **guest** user password (recommended for security)

Initializing these parameters permits configuration of all remaining settings through any one of the following ways:

- computer-aided configuration with **ezsetup** or **npconfig**
- configuration through the network with RARP
- configuration through the network with BOOTP
- configuration through the network with ARP

Once you have completed any one of these methods, you will see the STAT LED flashing once per second. This means the Internal Ethernet Adapter is configured and recognizable on the network. At this point, you can then configure a host for printing by continuing with “Host Configuration” on [page 156](#). This completes your entire print setup, unless you choose to enhance it.

## Computer-aided Configuration with ezsetup or npconfig

---

**NOTE:** If you choose computer-aided configuration, you must log on to your system as **root** or **superuser** and use the host software diskette supplied with your Internal Ethernet Adapter. If the software is not provided, or you need a different medium, contact your vendor.

To configure the Internal Ethernet Adapter with the aid of a script you must perform the following steps:

1. Insert the host software into the drive.
2. Login as **root** user.
3. **cd** to a directory with at least three megabytes of free space.

## Chapter 5 Configuring the Internal Ethernet Adapter for TCP/IP

---

- Transfer the compressed tar file from the media onto the host:  
`tar xvf /dev/devicename`  
*devicename* is usually **fd0** for a diskette.
  - Uncompress this file. Enter:  
`uncompress npdist.tar.1.Z`
  - Untar the file. Enter:  
`tar xvf npdist.tar.1`  
A list of files displays and scrolls up the screen as **tar** executes and several file and sub-directories are created.
  - Assign an IP address and IP name to the Internal Ethernet Adapter in your host table (**/etc/hosts**, **hosts nis** map, or DNS name tables).
  - Run **ezsetup** or **npconfig**. Enter:  
`./ezsetup` or `./npconfig`
- NOTE:** If running the host software on an HP-UX<sup>®</sup> system, you will need to explicitly set the Korn shell by adding “**ksh**” before **.ezsetup** or **.npconfig**.
- Enter the number for **Configure New Unit** from the Main Menu.
  - Follow the prompts.

For more information, see `ezsetup` and `npconfig` on [page 147](#).

### Configuration Through the Network with ARP

---

To configure the Internal Ethernet Adapter using the network, go to a host terminal and do the following:

- Log on to your system as **root** user.
- Assign an IP address and an IP name to the Internal Ethernet Adapter in your host table (**/etc/hosts**, **hosts nis** map, or DNS name tables).
- Find the Ethernet address for the Internal Ethernet Adapter on the bottom of the unit. It must be entered as part of this procedure.
- Use the **arp** command to add an entry in the host's **arp table**. The following is the most common syntax for this command:  
`arp -s ipname ethernetaddress`  
Where *ipname* is the Internal Ethernet IP name or IP address and *ethernetaddress* is that of the Internal Ethernet Adapter.



## Configuration Through the Network with ARP

---

5. **telnet** to the Internal Ethernet Adapter. This will bring up a login screen.  
`telnet ipname`

6. Log on to the Print Server as **root**.

7. At the password prompt, press **<Enter>**. No password is required at this point as the Internal Ethernet Adapter is still unconfigured.

**NOTE:** This WARNING message is normal at this point and should be ignored:

STORED AND CURRENT VALUES DIFFER

You should now see a prompt displayed having the Internal Ethernet Adapter followed by a colon, then **root**.

`ipaddress:root>`

8. Store the new IP address and netmask in EEPROM so the Internal Ethernet Adapter remembers its configuration after rebooting.

Enter:

`store tcpip ifnum addr ipaddress`

`store tcpip ifnum mask netmask`

**NOTE:** *ifnum* is the index to a particular Network Interface. *ifnum* will always be 1 for the Internal Ethernet Adapter.

9. [Optional, but recommended] Configure root and guest user passwords with the following commands:

`set user passwd root newrootpasswd`

`set user passwd guest newguestpasswd`

10. Save these configurations to EEPROM. Enter:

`save`

11. Verify the IP address and netmask. Enter:

`list stored tcpip`

These are now stored in EEPROM.

12. Log out of the Telnet session with **quit**. Reboot the Internal Ethernet Adapter by powering the unit off, then on.

13. Test the equipment and configuration after installation is complete. Enter at the shell prompt on your UNIX machine:

`ping ipname`

## Configuration Through the Network with RARP

---

The RARP daemon provides a mechanism for dynamic IP address assignment. When a RARP-configured TCP/IP host boots, it broadcasts a RARP request for an IP address. Your network must have this daemon running on some host. If you do not know whether your network has one, ask your system administrator or configure the Internal Ethernet Adapter with one of the other methods in this section.

To configure the Internal Ethernet Adapter with RARP you need to:

1. Make an entry in the **/etc/ethers** file for the new Internal Ethernet Adapter:  
`00:80:72:00:AB:CD:spike`  
entry for the Internal Ethernet Adapter named **spike** which has this Ethernet address.
2. Start the RARP daemon if it isn't running. Send a HUP signal to it with the **kill** command:  
`kill -HUP pid`
3. Power the printer down and then up, wait another ten seconds to allow the RARP process to complete.
4. Test the new IP address by trying a **ping** with the new IP name:  
`ping ipname`
5. [Optional, but recommended] At this point set up the user passwords.

If no response is given by the Internal Ethernet Adapter, the RARP process probably failed. Reboot the unit and try one of the other methods mentioned in this section.

### Configuration Through the Network with BOOTP

---

BOOTP is a protocol for configuring the Internal Ethernet Adapter as it boots. During the boot sequence, the Print Server can broadcast a BOOTP request and if a BOOTP server is running on the network configured to respond to the requesting device, it will provide the Internal Ethernet Adapter with its IP address, netmask, default router, and a time server from which to query the current time (GMT) and the timezone in which the Internal Ethernet Adapter is located.

By default, the Print Server will broadcast a BOOTP request when it boots. The following command can be used to control this request:

```
store tcpip ifnum opts [[-]bootp]
```

On the BOOTP server, there must be an entry in **/etc/bootptab** similar to the following:

```
M205:\
:sm=netmask:\
:hd=/usr/boot:\
:bf=null:\
:gw=default router.\
:ht=ethernet:\
:ha=network address:\ (i.e. 0080720000DC)
:ip=ipaddress:\
:ts=time server.\
:to=timezone: (in seconds from GMT)
```

### Restoring Factory Defaults

---

If at any time you would like to restore the Print Server's *network* settings to their original state, you can perform a **npsh** command or utilize the dipswitches on the Internal Ethernet Adapter itself.

## Host Configuration

---

When setting up a print destination on a UNIX host, you have the option of using a computer-aided script such as **ezsetup**, **npconfig**, or performing the appropriate steps manually.

If you use one of the installation scripts provided, select **Configure Host Setup** from the Main Menu of either program to configure a print setup on your host. It will help you through some questions and perform the necessary setup commands for you.

The rest of this section introduces you to different printing methods, with the spooler and without, and discusses each of the steps for each environment:

BSD

System V

Sun NeWSprint and Adobe® TranScript®

AIX®

PC

## Direct Printing Without Spooler

---

Before configuring the spooling system, test that the basic communications are working with the Internal Ethernet Network printer. Perform test by sending print jobs directly to the Internal Ethernet Network printer and bypassing the spooler altogether. You can send print jobs directly to the Internal Ethernet Network printer with either **npwrite** or **rsh/rcmd/remsh**.

The **rsh/rcmd/remsh** program provides the same functions as the **npwrite** program except that the **rsh/rcmd/remsh** program exits with an error code when the network connection is down. **npwrite** continually tries until the job is completed. Remember this behavior when you are manually modifying your interface script because some spooler systems simply send a message about the error but the error gets flushed. The **npr.if** interface script gives you examples of how this behavior should be handled.

### **npwrite**

The data transfer program **npwrite** is provided with the host software shipped with your 5525B/31/32 Internal Ethernet Network printer. It sends data to the printer over a TCP connection. Data is read from a file or, if no file is specified, from standard input. The format of the data is not altered by this program; be certain it is in print-ready format.

This syntax for **npwrite** is as follows:

```
npwrite ipname portname [filename]
```

Where:

**ipname** Internal Ethernet Adapter IP name or IP address

**portname** I/O port on the Internal Ethernet Adapter (i.e. prn)

**filenames** [optional] File name(s) to be printed. If no filename is specified, data is read from standard input.

For example:

```
npwrite 192.75.11.32.prn testfile.txt  
cat testfile.txt | npwrite 192.75.11.32.prn
```

where **192.75.11.32** is the Internal Ethernet Adapter's IP address.

If the **npwrite** binary is not available on your machine, use **rsh/rchmd/remsh** instead.

### **rsh/rcmd/remsh**

The **rsh/rchmd/remsh** programs are remote command execution clients that talk to the **rshd** server in the Internal Ethernet Adapter. **rsh**, **rcmd**, and **remsh** are the same programs but have different names on different UNIX systems.

The Internal Ethernet Adapter provides **lp**, **lpstat**, and **cancel** program for print services through the **rshd** server. The **lp** command reads data from the standard input and sends it to the specified port as follows:

- on SCO UNIX, use either of the following:

```
rcmd spike lp -d dlprn < testfile.txt  
cat testfile.txt | rcmd spike lp -d dlprn
```
- On Sun UNIX

```
rsh spike lp -d dlprn < testfile.txt  
cat testfile.txt | rsh spike lp -d dlprn
```

## Chapter 5 Configuring the Internal Ethernet Adapter for TCP/IP

---

where **spike** is the Internal Ethernet Adapter's IP name and **d1prn** is the destination.

### Printing Via the Spooler

---

Once you know your communications are correct and you can successfully print directly to the printer, you can integrate the spooler.

Interface scripts play important roles in BSD spooling environments and especially with System V print spoolers. BSD systems also provide a remote printing method utilizing the spooler but needs no script or host software.

The following sections elaborate on different spooling environments and provide the steps for full host configuration in various environments. **ezsetup** or **npconfig** can be used in most cases to simplify the process.

#### npr.if Interface Script

The **npr.if** interface script provided works in most environments, but can be replaced by a custom interface script if you have other requirements. It is usually a UNIX script which reads the parameters from the command line, processes the job according to the parameters, and sends it to the destination.

Two interface scripts, **nprbsd.if** and **nprsysv.if**, are shipped in the raw state. Load the appropriate script for your system spooler type and use it in this state if the Internal Ethernet Adapter can do sufficient processing. The Internal Ethernet Adapter contains enough processing options, when they are activated, to handle most processing needs without the need of host software. Thus, host software may be unnecessary and you may turn off all processing options on the host.

**NOTE:** If you require high-speed printing, use one of the interface scripts with the host processing turned on. This removes processing load from the Internal Ethernet Adapter and increases printing throughput.

Both **ezsteup** and **npconfig** utilizes the appropriate interface script by renaming it to **nprprintername.if**, where **printername** is the name of the printer on the host.

## Custom Interface Scripts

---

You have three choices of interface scripts:

- **npr.if** provided in the host software
- A pre-defined script for your particular printer
- A script you have created yourself

The **npr.if** method is explained throughout this section. However, if you have a pre-defined printer script or a script of your own, there are certain modifications you must make in order for it to work with the Internal Ethernet Adapter.

With the Internal Ethernet Adapter, the data must be captured and sent over the network for printing, since your printer is no longer locally attached. Use one of the following two methods:

1. Encapsulate your script's code with brackets () and, after the closing bracket, add a command to send the data to the Internal Ethernet Adapter for printing.
2. Use **npd** as the print method.

Both methods are explained in detail below.

### Modifying Your Script

If you choose to simply edit the script, you need to understand how an interface file works. The structure of any standard interface file should be as follows:

```
process options
(
generate printer setup characters
generate banner page data for each file
translate data to printer format
) | communication program
```

where *communication program* is the program executing **rsh/rcmd/remsh** or **npwrite** so the print job is redirected over the network to the Internal Ethernet Adapter.

```
(
FILE=$6
#the spool file is found in the sixth parameter on System
V
cat $FILE | onlcr
```

## Chapter 5 Configuring the Internal Ethernet Adapter for TCP/IP

---

```
#filter the job
) | rcmd spike lp -d d1prn
```

where **spike** is the name of the Internal Ethernet Adapter and print jobs are being sent to its destination **d1prn** by remotely executing the Internal Ethernet Adapter's **lp** print command.

**NOTE:** Even if you have a very simple script, it's important that you enclose your script with brackets then add in a *communication program* at the end.

### Using npd and Your Own Script

If **npd** is the chosen print method, start the npd daemon on your host and incorporate it into your print setup. See [page 166](#) for more information on **npd**.

Once you have this daemon running, you can work it into your printer configuration. For BSD systems, this requires an **lp=** field in your printcap entry along with the standard **if=** field for the name of your interface script. The **lp=** field is filled in with the name of the **npd devicefile** used in **npd**'s startup command. If you have a System V setup, the **-v** option in the **lpadmin** command will equal the **npd devicefile**.

## BSD UNIX

---

BSD systems allow you to print remotely or with an interface file for a locally attached printer. This is configured within the **/etc/printcap** database.

### lpd Remote Printing

The lpd daemon spools files locally, then sends them to the Internal Ethernet Adapter acting as a remote printer. As interface scripts cannot be used with this spooling method, processing must be done by the Internal Ethernet Adapter.

This method should be used under the following conditions:

- your UNIX host supports BSD 4.3 LPD protocol
- no bi-directional communication is required between the printer and printing application
- you wish to avoid using special host software



The control file usually contains valid information about originating user and host. The contents are only used to gather log information on the printed jobs. Since the control file may not arrive before the data file in the current LPD standards, fully detailed banners cannot be guaranteed.

## Setting up lpd Remote

To add an Internal Ethernet Adapter as a remote printer entry on your BSD UNIX host, you need to add an entry to the `/etc/printcap` file and create its associated file and directories. The following is an example of what the printcap should look like, with a description of the commands necessary to create these entries:

```
ps|PostScript printer on spike's prn port:\
:lp=:\
:rp=dlprn:\
:rm=spike
:sd=/usr/spool/lpd/spike/ps:\
:lf=/usr/spool.lpd/spike/ps/log:\
:af=/usr/spool.lpd/spike/ps/acct:
```

Where **ps** is the printer name sending jobs to the destination **d1prn** on the Internal Ethernet Adapter named **spike**.

To create the necessary entries for this example, use the following commands:

```
cd /usr/spool/lpd
mkdir spike
mkdir spike/ps
touch spike/ps/log spike/ps/acct
chown -R daemon.daemon spike
chmod -R g+rwX,o+rX spike
```

You can then start this printer.

```
lpc start ps
```

To send a job, use this syntax:

```
lpr -Pprintername filename
```

## BSD Interface Script Printing

If you choose not to use a remote printer setup, you can use an interface file. This interface script is specified in `/etc/printcap` with the **if=** entry rather than the **rm=** and **rp=** entries. This script is called by the lpd daemon with the following syntax:

```
nprbsd.if -wwidth -llength -iindent -nlogin -hhost acct_file
```

where

<i>nprbsd.if</i>	Name of the interface script
<i>width</i>	Width of page in characters
<i>length</i>	Length of page in inches
<i>indent</i>	Number of characters of indent from left margin
<i>login</i>	Login name of user originating print request
<i>host</i>	Name of host where the print job originates
<i>acct_file</i>	File where accounting data is stored

### Setting up an Interface Script

To set up your host with an interface file, add an entry to the */etc/printcap* file, then create and edit its associated files and directories.

The following is an example of the printcap entry, followed by the necessary command for creation of the entries:

```
hp:\
:sh:pw#80:mx#0\
:lp=/dev/spike.prn:\
:sd=/usr/spool/lpd/spike/prn:\
:lf=/usr/spool/lpd/spike/prn/log\
:af=/usr/spool/lpd/spike/prn/acct:\
:if=/usr/spool/lpd/spike/prnnpr.if:
```

Where **hp** is the printer name sending jobs to the Internal Ethernet Adapter named spike through the interface file **npr.if**. To create these entries, do the following:

1. Create the printer's spooling directory and associated files.

```
cd /usr/spool/lpd
mkdir spike
mkdir spike/prn
touch spike/com2/log spike/ps/acct
chown -R daemon.daemon spike
chmod -R g+rwX,o+rX spike
```

2. Copy the **nprbsd.if** file from the host software to the spool directory. Copy the file as **npr.if** or name it as something more meaningful.

```
cp nprbsd.if /usr/spool/lpd/spike/prn/npr.if
cd /usr/spool/lpd/spike/prn
chown daemon.daemon npr.if
chmod g+rwX,o+rX spike
```

3. Edit the **npr.if** variables to suit your system environment. Look for the comment section beginning with "EDIT THESE VARIABLES" and at the end of this comment block, you will find the following:

When defining these variables, remember each is *case sensitive*. Define them as illustrated in these descriptions.

**NPDIR\_PATH** (mandatory) Define the directory location of **chr**, **banner**, **onlcr**, and **npsscramble** binaries. Usually **/usr/local/bin**.

These binaries must be copied over from the host software.

**COMM\_PROG** (mandatory) Specify a communication program to transfer the data to the Internal Ethernet Adapter (i.e. **npwrite**, **rsh**). If the program is **npwrite**, define the **UNIT\_PORT** variable. Otherwise, define the **LP\_DEST** variable.

**PRINTER\_TYPE** (mandatory) Specify printer type (i.e. **raw**, **ascii**, **ps**, **hp**, **gen7170**).

**UNIT\_PORT** (conditional) Specify the Internal Ethernet Adapter port name (i.e. **prn**). Use only when **COMM\_PROG** is defined as **rsh**.

For example:

```
#END_MARK_1
NPDIR_PATH= ./USR/LOCAL/BIN
COMM_PROG=rsh
UNIT_NAME=spike
LP_DEST=d1prn
PRINTER_TYPE=hp
BANNERPAGE=1
#START_MARK_1
```

**NOTE:** Additional variables can also be identified within this variable section as indicated by **BANNERPAGE=1**. Some other options include ASCII to PostScript conversion, carriage return insertion, and scrambling. By setting a particular variable to 1, this option is then turned on and a 0 turns it off.

4. Create the LP= device used as a locking mechanism for contending print jobs.

```
touch /dev/spike.prn
chmod go+rw /dev/spike.prn
```

5. Start the print spooler.

```
lpc start hp
```

6. Print with the following syntax:

```
lpr -Pprintername filename
```

## System V UNIX

---

Printing in a System V environment requires the use of an interface file. It also consists of:

- the **lp** printer interface program
- the **lpsched** printing scheduler
- a set of programs acting as interfaces between the scheduler and printing device.

The scheduler copies the files into a spooling directory and calls the interface program when the job is ready to go the Internal Ethernet Adapter. It processes the job according to the script's setting and sends it to the printer for printing.

The interface script is usually kept in **/usr/spool/lp/admins/lp/interfaces** and carries the same name as the associated printer. It is copied from the original interface file in **/usr/spool/lp/model** when the **lpadm** command is executed.

The interface script is called with the following syntax:

```
ps203 reqid username copies options file1 ...
```

where:

<i>ps203</i>	Name of the interface script which is also the printer name on the host
<i>reqid</i>	Print job identification
<i>username</i>	ID of the user requesting the job
<i>title</i>	Title of the print job required
<i>copies</i>	Number of copies for each file to be printed
<i>options</i>	Additional switches for any extra job processing options
<i>file1</i>	spool file
<i>...</i>	Indicates additional spool files

## Setting up an Interface Script

The following steps are the instructions for setting up your host with **npr.if**.

**NOTE:** The commands provided represent a print setup involving a printer named **hp**, an Internal Ethernet Adapter named **spike**, and a printer attached to the Print Server's **com2** port.

1. Copy the **nprsysv.if** file from the host software to the model directory. Copy the file as **npr.if** or name it something more meaningful.  

```
cp nprsysv.if /usr/spool/lp/model/npr.if
```
2. Edit the **npr.if** variables to suit your system environment. Look for the comment section beginning with "EDIT THESE VARIABLES" and at the end of this comment block, you will find the following:

When defining these variables, remember each is *case sensitive*. Define them as illustrated in these descriptions.

**NPDIR\_PATH** (mandatory) Define the directory location of **chr**, **banner**, **onlcr**, and **npsscramble** binaries. Usually **/usr/local/bin**.

These binaries must be copied over from the host software.

**COMM\_PROG** (mandatory) Specify a communication program to transfer the data to the Internal Ethernet Adapter (i.e. **npwrite**, **rsh**, **rcmd**, **remsh**). If the program is **npwrite**, define the **UNIT\_PORT** variable. Otherwise, define the **LP\_DEST** variable.

**PRINTER\_TYPE** (mandatory) Specify printer type (i.e. **raw**, **ascii**, **ps**, **hp**, **gen7170**).

**UNIT\_NAME** (mandatory) Define the Internal Ethernet Adapter IP name

**UNIT\_PORT** (conditional) Specify the Internal Ethernet Adapter port name (i.e. **prn**). Use only when **COMM\_PROG** is defined as **npwrite**.

## Chapter 5 Configuring the Internal Ethernet Adapter for TCP/IP

---

For example:

```
#END_MARK_1
NPDIR_PATH=./usr/local/bin
COMM_PROG=rcmdsh
UNIT_NAME=spike
LP_DEST=dlprn
PRINTER_TYPE=hp
BANNERPAGE=1
#START_MARK_1
```

**NOTE:** Additional variables can also be identified within this variable section as indicated by **BANNERPAGE=1**. Some other options include ASCII to PostScript conversion, carriage return insertion, and scrambling. By setting a particular variable to 1, this option is then turned on and a 0 turns it off.

3. Create the dummy output device used as a locking mechanism between contending print jobs.

```
touch /dev/spike.prn
chmod go+rw /dev/spike.prn
```

4. Install a new printer specifying printer name, interface script name, and dummy device.

```
/usr/lib/lpadmin -php -mnpr.if -v/dev/spike.prn
```

5. Start the scheduler

```
lpsched
```

6. Enable the printer and allow it to accept requests.

```
enable hp
accept hp
```

7. Print a file with the following syntax:

```
lp -dprintername filename
```

### npd Pseudo-device Interface

---

The npd pseudo-tty daemon is used when bi-directional communication is required between printer and printing application, and when changes to the printer's interface script are undesirable.

Some applications such as Sun NeWSprint work best with a bi-directional communication channel to the printer because they can provide more details on the printer status. **npd** is used in this case using the TCP protocol and pseudo-tty device drivers.

### Starting npd

## npd Pseudo-device Interface

---

Starting the **npd** daemon is all that is needed to utilize **npd**. Integrating any special applications can be done anytime thereafter.

Use the following syntax to start **npd**:

```
npd devicefile ipname portname
```

where :

*devicefile*      Name for a pseudo-tty pair's slave device acquired by  
**npd**

*ipname*            Internal Ethernet Adapter IP name or IP Address

*portname*         Internal Ethernet Adapter I/O port name (i.e. **prn**)

**NOTE:** The *devicefile* cannot exist prior to starting **npd** and this particular **npd** daemon cannot be running already. You can have more than one daemon running on the same host, as long as they are not using the same *devicefile*.

```
npd /dev/spike.prn spike prn
```

starts an **npd** daemon utilizing **/dev/spike.prn** to send print jobs to the printer attached to the parallel port on the Internal Ethernet Adapter named **spike**.

By default, **npd** looks in the **/dev** directory to find a free pseudo-tty pair (**/dev/pty??** and **/dev/tty??** files). If your UNIX system has these files in a different directory, you can specify the directory pathname with a **-p** option.

```
npd -p /dev/pty /dev/spike.prn spike prn
```

where **/dev/pty** is the directory to be searched for a free pseudo-tty pair. Some systems, such as HP-UX, place the master and slave devices in separate directories (i.e. **/dev/ptym** and **/dev/pty**). Specify where each of the pairs reside with the **-pm** and **-ps** options.

```
npd -pm /dev/ptym -ps /dev/pty /dev/spike.prn spike prn
```

where **/dev/ptym** is the directory searched to find a free pseudo-tty pair's master device and **/dev/pty** is the directory used for locating the pseudo-tty pair slave device.

### npd locks

As **npd** acquires an exclusive lock on the Internal Ethernet Adapter port, it is possible to lock out other daemons that may reside on other UNIX hosts. Therefore, **npd** is designed to timeout and release the lock if the pseudo-tty pair is idle for a specified time (30 seconds). You can modify this value with the **-t** option.

```
npd -t 60 /dev/spike.prn spike prn
```

for the timeout to occur in 60 seconds.

### Testing npd

Once **npd** has been started, test to see if **npd** is working before attempting to print through the spooler. The following is one test method:

```
cat test.txt > /dev/spike.prn
```

redirects the cat output of `test.txt` to the **npd** device `/dev/spike.prn` which is then sent to the Internal Ethernet Adapter named **spike**.

### Modifying a Host to Use npd

If you want the **npd** daemon to start every time you reboot your UNIX machine, edit your **-rc** file to include the appropriate **npd** startup command (from the previous section). After **npd** starts, integrate the print spooler into this pseudo-tty setup.

In BSD print spooler systems, modify the **lp=** field in the appropriate printer entry in `/etc/printcap` file. Set **lp=** to the *devicefile* argument of the **npd** program.

On System V systems, the **-v** option in the **lpadmin** command will equal the *devicefile*.

### Stopping npd

Whenever an **npd** daemon starts, it makes a log entry in the `/usr/adm/npdlog` file. The contents of this file have the following naming information:

```
pid ipname port masterfile slavefile devicefile
```



## npd Pseudo-device Interface

---

where:

*pid* Process ID of **npd** daemon  
*ipname* Internal Ethernet Adapter IP address or IP name serviced by **npd**  
*port* Internal Ethernet Adapter I/O port used by **npd** (i.e. **prn**)  
*masterfile* Master device used by **npd**  
*slavefile* Slave device used by **npd**  
*devicefile* Name linked to the slavefile by **npd**

```
153 spike prn/dev/ptyq1 /dev/ttyq1 /dev/spike.prn
```

is the log entry for the **npd** daemon using process ID 153.

You can acquire the process ID of the **npd** daemon that needs to be stopped and execute the following kill command for that process:

```
kill -TERM pid
```

## AIX

IBM has a unique print spooler system that uses the **qdaemon** program. Use the following steps to interface with the Internal Ethernet Adapter using **rsh**:

**NOTE:** These steps and associated examples refer to a setup with a queue named **queue2**, a queue device named **lp0**, printing to a destination **d1prn** on the Internal Ethernet Adapter named **spike**.

1. Create a device. Enter:  

```
smit pdp
```
2. Select **Printer/Plotter**, then **Add a Printer/Plotter**. Follow the prompts until SMIT executes the “**mkdev**” command to create this device.

**NOTE:** Select parallel as the interface.  
Select **p** as the *port number*.  
Select **ppa0** as the adapter.  
Select a printer type that best matches what you are doing.  
Select device **lp0**. If this device is not available, go back and select “Remove a Printer/Plotter” and remove **lp0** making it available for your next run through. AIX has a limit of four physical devices. If you run out, IBM suggests deleting the device after completing a print setup.

3. Create a new queue. Enter:  

```
mkque -q queue2
```

## Chapter 5 Configuring the Internal Ethernet Adapter for TCP/IP

---

4. Create a new queue device to do the one-to-one mapping with the printer and specify the backend program for the qdaemon to send print jobs to. Enter:

```
mkqueuedev -d lp0 -q queue2 -a 'backend = /usr/lib/lpd/piobe'
```

**NOTE:** Sometimes `/usr/lib/lpd/piobe` is the location of this backend program.

5. Create a virtual printer. This associates the queue, queue device, printer/plotter, name, data type, and printer/plotter type. Enter:

```
mkvirprt -q queue2 -d lp0 -n lp0 -s pcl -t hplj3
```

**NOTE:** `-s` is usually `pcl` but can also be `ps` (PostScript) or `asc` (ASCII). This does not seem to affect the output of the printer, so it may be best to use `pcl`.

6. Change the `pio-file` for your queue. This will be located in `/usr/lib/lpd/pio/custom` and will be called `queue2:lp0` after the queue and queue device names. Change the line beginning with `302 mo::`. Enter:

```
302 mo::rsh spike lp -d d1prn
```

**NOTE:** This file is only created after the `mkvirprt` command has been executed in step 5. This step redirects the print job over the network to the Internal Ethernet Adapter.

7. Run `chvirprt` since the print setup has been altered and needs updating. Enter:

```
chvirprt -q queue2 -d lp0
```

**NOTE:** If you need to delete an entire print setup, use the `rmvirprt` command.

This is the `/etc/qconfig` entry created for this particular setup:

queue2:	queue stanza
device = lp0	by mkqueuedev (queue device)
up = TRUE	printer's ready to go
lp0:	queue device stanza
backend=/user/lib/lpd/piobe	for local printing

## Other TCP/IP Methods

---

### NCSA

NCSA is a freeware package available on the Internet at **zaphod.ncsa.uiuc.edu** in the directory **/PC/Telnet/msdos/contributions**. The file is **tel23bin.zip**. It contains an **lpr** client for DOS that is compatible with the Internal Ethernet Adapter.

You can send jobs with the following syntax:

```
lpr -Sipname -Pdestname
```

Where **ipname** is the Internal Ethernet Adapter IP name or IP address and **destname** is the name of the Internal Ethernet Adapter destination.

```
lpr -Sspike -Pd1prn
```

sends a print job to **d1prn** on the Internal Ethernet Adapter named **spike**.

### FTP's PC/TCP

FTP Software<sup>®</sup> markets a package called PC/TCP which provides an **lpr** client for DOS that is compatible with the Internal Ethernet Adapter.

Jobs can be sent to the Internal Ethernet Adapter directly with the following command syntax after an entry has been made for the Internal Ethernet Adapter in the host table:

```
lpr -Sipname -Pdestname
```

Example:

```
lpr -Sspike -Pd1prn
```

sends a print job to **d1prn** on the Internal Ethernet Adapter named **spike**.

FTP's package also provides Windows<sup>®</sup> printing along with several other software packages on the market.

## Configuring The Internal Ethernet Adapter For Novell

---

This chapter introduces the Internal Ethernet Adapter's configuration possibilities along with the various methods of printing available within a Novell environment. The Internal Ethernet Adapter works with different NetWare<sup>®</sup> versions, including version 4, and we provide setup steps for each.

### Host Software

---

NetWare's PCONSOLE is generally used to change passwords, add print servers, add remote printers, and add queues to be serviced. It can be used for both a PSERVER or RPRINTER setup. To install an Internal Ethernet Adapter in a Novell environment, PCONSOLE is used for the entire installation. The following pages give step-by-step examples of installing the Internal Ethernet Adapter in various Novell environments.

**NOTE:** You can also use the NPWin software to configure the unit.

`npsh nvplist`

Lists all of the Internal Ethernet Adapter's on the network; each name is in the format **M\_XXXXXX** (where **XXXXXX** equals the last six digits of the unit's Ethernet address) by defaulting regardless of whether it is configured as a PSERVER or an RPRINTER.

`npsh unitname`

Starts a Telnet-like session with the named Internal Ethernet Adapter allowing you to configure, monitor, and troubleshoot the unit with its built-in command set.

`npsh unitname command`

Initiates a single **command** with **guest** access only to the unit instead of entering into a complete session.

To communicate with the unit using npsh.exe, you need to:

1. From a DOS prompt on a Novell workstation, begin an **npsh** session with the unit.

`npsh unitname`

Starts a Telnet-like session with the named print server with **guest** access only.

## Internal Ethernet Adapter

---

2. To obtain **root** access to the unit, type:

**supervisor**

A standard login screen is displayed prompting you for the login name and password.

3. Login to the unit as a **root** user.

**root**

**NOTE:** Root users require the use of a password as configured in the unit's user list.

4. Enter the password. If this password is not yet set, press **enter** at the password prompt. Otherwise, enter the password that is already stored on the unit.

*password*

You are now logged in to the unit as a **root** user and can access any **nps** command on the unit.

**NOTE:** Because **nps.exe** makes use of broadcasts, you may have problems communicating across a router.

## Internal Ethernet Adapter

---

The Print Server configuration in a Novell environment is much simpler than that required in a TCP/IP environment. No addresses, masks, or router entries are necessary and in most cases, the Internal Ethernet Adapter can simply be connected to the network, turned on, and then configured for printing from a Novell station through PCONSOLE. The only parameters that you may want to set are a PSERVER password or possibly the frame type. This type of configuration is done using **nps.exe** as detailed in the previous section.

## Host Configuration

---

The Internal Ethernet Adapter can act as either a PSERVER or as an RPRINTER in a Novell environment. It supports encrypted passwords and it is capable of servicing up to 16 file servers and 32 queues as a PSERVER. One Internal Ethernet Adapter can handle eight RPRINTER setups.

### PSERVER Bootup

When booting as a PSERVER, the Internal Ethernet Adapter gets a server list from the first file server it contacts. The unit then contacts those servers on that list to see if there is a queue that needs servicing. The queues are then polled every 5 seconds (by default) by the Print Server to see if there are any print jobs queued.

### RPRINTER Bootup

When booting as an RPRINTER, the Internal Ethernet Adapter again gets a server list from the first file server it contacts. For each server found on that list, it then looks for a file called **SYS:\LOGINM\_XXXXXX\CONFIG** where **XXXXXX** equals the last six hexadecimal digits in the Ethernet address found on the bottom of the unit. This file contains one **set rprinter** command for each RPRINTER serviced by the Internal Ethernet Adapter since the RPRINTER settings do not hold their effect through a power cycle.

**NOTE:** If the Internal Ethernet Adapter loses a connection to a file server (as a PSERVER) or to a PSERVER (as an RPRINTER), it will automatically reconnect when that server becomes available again.

Following are the configuration steps for a PSERVER setup, an RPRINTER setup, as well as the options available for NetWare 4 environments.

## PSERVER Setup (Pre-NetWare 4)

This procedure configures the Novell file server to use an Internal Ethernet Adapter as a PSERVER in a non-NetWare 4 environment. Please see "NetWare 4 Options" on [page 180](#) for more on a NetWare 4 setup.

**NOTE:** The Internal Ethernet Adapter **replaces** a dedicated workstation running PSERVER.EXE or PSERVER.NLM on the file server, so these are no longer needed.

To set up the unit as a PSERVER in a non-NetWare 4 environment, follow the procedure outlined in [Table 11](#).

**Table 11. PSERVER Setup (Pre-NetWare 4)**

Step	Action	Result of Action
1.	Log in to Novell as <b>supervisor</b> .	Gives you supervisor rights.
2.	Enter <b>PCONSOLE</b> .	PCONSOLE's Main Menu displays.
3.	Select PRINT QUEUE INFORMATION.	List of currently-defined queues comes up.
4.	Press <b>&lt;Insert&gt;</b> to add a queue.	Asks for new queue's name.
5.	Type in this new name in any format you like and press <b>&lt;Enter&gt;</b> .	New queue is added to list.
6.	Press <b>&lt;Escape&gt;</b> .	Returns to PCONSOLE's Main Menu.
7.	Select PRINT SERVER INFORMATION.	A list of existing print servers displays.
8.	Press <b>&lt;Insert&gt;</b> to add a server.	Prompts for the server's name.
9.	Type the name of the Internal Ethernet Adapter. By default, it is <b>M_XXXXXX</b> where <b>XXXXXX</b> equals the last six digits of the unit's Ethernet address. (e.g. M_000BF5)	This new server is added to the list.
10.	Select it and press <b>&lt;Enter&gt;</b> .	PRINT SERVER INFORMATION menu comes up.

## Chapter 5 Configuring The Internal Ethernet Adapter For Novell

Table 11. PSERVER Setup (Pre-NetWare 4) (continued)

Step	Action	Result of Action
11.	Select PRINT SERVER CONFIGURATION.	This menu displays.
12.	Select PRINTER CONFIGURATION.	A list of configured printers is displayed.
13.	Select the first item listed as NOT INSTALLED and press <Enter>.	The PRINTER <i>N</i> CONFIGURATION window comes up where <i>N</i> equals the selected printer.
14.	Type in the name of one of the eight default destinations on the unit for the <b>Name</b> field (e.g. d1prn, d2prn, etc.) and go to the <b>Type</b> field.	Cursor sits at the <b>Type</b> field with a printer name now assigned.
15.	Press <Enter> at this field and then select DEFINED ELSEWHERE.	Comes back to the PRINTER <i>N</i> CONFIGURATION window.
16.	Press <Escape> and select <b>Yes</b> to save changes.	Gives you the option to define more printers.
17.	Press <Escape> again.	Returns to PRINT SERVER CONFIGURATION menu.
18.	Select QUEUES SERVICED BY PRINTER.	A list of defined printers displays.
19.	Select one of these printers.	A list of queues comes up. It will be empty the first time you use it.
20.	Press <Insert>.	Displays a list of available queues.
21.	Select the queue created earlier to service this printer and press <Enter>.	Asks for a priority.
22.	Press <Enter> to select the default. This is fine for most cases.	Comes back to queue list.
23.	Press <Escape> back to Main Menu	Main Menu displays.



## RPRINTER Setup (Pre-NetWare 4)

---

Table 11. PSERVER Setup (Pre-NetWare 4) (continued)

Step	Action	Result of Action
24.	Reboot the Print Server by unplugging and plugging it back in.	Unit will boot up and see the new queue that it has to service. This may take a minute.
25.	Check CURRENTLY ATTACHED SERVERS once you have gone into view the appropriate queue.	You should see the Print Server's name displayed (e.g. M_000BF5).
26.	Press <Escape> until you have exited PCONSOLE.	The configuration is complete.

## RPRINTER Setup (Pre-NetWare 4)

---

This procedure associates an existing PSERVER with a remote Internal Ethernet Adapter acting as an RPRINTER in a pre-NetWare 4 environment. It is the PSERVER's responsibility to get jobs from the queue and to pass them off to the Internal Ethernet Adapter acting as the remote printer. Unlike a PSERVER set-up, the Internal Ethernet Adapter does not deal directly with the queues.

**NOTE:** As an RPRINTER, the Print Server does not use a login ID. In addition, a non-Internal Ethernet Adapter (e.g. PSERVER.NLM) must be running for RPRINTER to operate.

An RPRINTER set up requires the use of a configuration file. This file is required to tell the Internal Ethernet Adapter to act as an RPRINTER upon boot up since RPRINTER settings do not hold their effect through a power cycle. Once the unit boots up, the Internal Ethernet Adapter contacts file servers it knows and on each Print Server looks for the file **SYS:\LOGINM\_XXXXXX\CONFIG** where **XXXXXX** equals the last six digits (in hexadecimal) of the Ethernet address as found at the bottom of the unit. If it finds this file, it reads in each entry as if it were an **npsh** command entered right on the unit.

**NOTE:** To ensure that the Internal Ethernet Adapter contacts the file server that contains the CONFIG file, set up the appropriate file server as a preferred file server.

## Chapter 5 Configuring The Internal Ethernet Adapter For Novell

**CAUTION** If you are using a configuration file and you have changed the name of the Internal Ethernet Adapter, you must change the name of the directory containing this file.

To set up the unit as an RPRINTER in a pre-NetWare 4 environment, follow the procedure outlined in [Table 12](#).

**Table 12. RPRINTER Setup (Pre-NetWare 4)**

Step	Action	Result of Action
1.	Log in to Novell as <b>supervisor</b> .	Gives you supervisor rights.
2.	Enter <b>PCONSOLE</b> .	PCONSOLE's Main Menu displays.
3.	Select PRINT QUEUE INFORMATION.	List of currently defined queues comes up.
4.	Press <b>&lt;Insert&gt;</b> to add a queue.	Asks for new queue's name.
5.	Type in this new name in any format you like and press <b>&lt;Enter&gt;</b> .	New queue is added to list.
6.	Press <b>&lt;Escape&gt;</b> .	Returns to PCONSOLE's Main Menu.
7.	Select PRINT SERVER INFORMATION.	A list of existing print servers displays.
8.	Select one of the print servers and press <b>&lt;Enter&gt;</b> .	Display's PRINT SERVER INFORMATION menu.
9.	Select PRINTER CONFIGURATION.	Displays a list of printers associated with the print server.
10.	Select or create a printer name which you want to install as a remote printer and press <b>&lt;Enter&gt;</b> .	PRINTER N CONFIGURATION window displays where N equals the selected printer.
11.	Put the cursor on the Type field and press <b>&lt;Enter&gt;</b> .	A list of options comes up.
12.	Select REMOTE OTHER/UNKNOWN.	This displays in the <b>Type</b> field.
13.	Ignore the other fields and press <b>&lt;Escape&gt;</b> to save these changes.	Takes you back to the list printers.

## RPRINTER Setup (Pre-NetWare 4)

**Table 12. RPRINTER Setup (Pre-NetWare 4) (continued)**

Step	Action	Result of Action
14.	Press <Escape> until you are at the PRINT SERVER CONFIGURATION menu again.	Displays this menu.
15.	Select QUEUES SERVICED BY PRINTER.	A list of defined printers for this print server is shown.
16.	Select the printer you previously defined and press <Enter>.	An empty queue list comes up.
17.	Press <Insert>.	A list of available queues displays.
18.	Select the queue you want this printer to service and press <Enter>.	Prompts you for a priority.
19.	Press <Enter> to use the default.	Returns to the queue list.
20.	Press <Escape> until you have exited PCONSOLE.	Takes you to the command prompt.
21.	Start PSERVER.	Starts the PSERVER so the Internal Ethernet Adapter can service it as an RPRINTER.
22.	In SYS VOLUME on the file server, change to the \LOGIN directory.	You will be at this prompt.
23.	Create a directory named after the Internal Ethernet Adapter. By default, this will be M_XXXXXX where XXXXXX equals the last six digits of the unit's Ethernet address (e.g. M_000BF5)	Creates the directory.
24.	Within this directory, create a file called CONFIG and open it for editing.	A blank file displays.

## Chapter 5 Configuring The Internal Ethernet Adapter For Novell

Table 12. RPRINTER Setup (Pre-NetWare 4) (continued)

Step	Action	Result of Action
25.	Enter the line: <code>set rprinter add pservername printernumber destname</code> where <b>pservername</b> equals the existing PSERVER's name, <b>printernumber</b> equals the defined number for this printer in that PSERVER, and <b>destname</b> equals an Internal Ethernet Adapter destination (e.g. d1prn d2prn, etc.).	One entry is written in the file. One entry is required for each RPRINTER serviced by the Internal Ethernet Adapter.
26.	Reboot the Internal Ethernet Adapter to enable these changes.	The Internal Ethernet Adapter will boot up and read this entry from the <b>CONFIG</b> file and set itself to act as an RPRINTER.

### NetWare 4 Options

NetWare 4 introduces NDS and some new frame types. The Internal Ethernet Adapter can be used in a NetWare 4 environment with either of these options:

- Set the Internal Ethernet Adapter up as a PSERVER
- Set the Internal Ethernet Adapter up as a RPRINTER interacting with an existing PSERVER.

**NOTE:** If following a PSERVER setup, bindery emulation is required.

Included in this sub-section are the steps for a PSERVER setup since the steps have changed now that bindery emulation is required. A PRINTER setup is not included since the only changes from a pre-NetWare 4 RPRINTER setup are some name changes in PCONSOLE.

To configure the unit as a PSERVER in a NetWare 4 environment, follow the procedure outlined in [Table 13](#).

Table 13. PSERVER Setup (NetWare 4)

Step	Action	Result of Action
1.	Log in to Novell as <b>supervisor</b> .	Gives you supervisor rights.
2.	Enter <b>PCONSOLE</b> .	PCONSOLE's Main Menu displays.
3.	Press <b>F4</b> .	Puts you into bindery emulation mode and displays Main Menu.
4.	Select PRINT QUEUES.	List of currently defined queues comes up.
5.	Press <b>&lt;Insert&gt;</b> to add a queue.	Asks for new queue's name.
6.	Type in this new name and press <b>&lt;Enter&gt;</b> .	New queue is added to list.
7.	Press <b>&lt;Escape&gt;</b> .	Returns to PCONSOLE's Main Menu.
8.	Select PRINT SERVERS.	A list of existing print servers displays.
9.	Press <b>&lt;Insert&gt;</b> to add a new print server.	Prompts you for the name of the print server.
10.	Type the name of the Internal Ethernet Adapter. By default, it is <b>M_XXXXXX</b> where <b>XXXXXX</b> equals the last six digits of the unit's Ethernet address. (e.g. M_000BF5)	This new server is added to the list.
11.	Select this new print server and press <b>&lt;Enter &gt;</b> .	PRINT SERVER INFORMATION menu displays.
12.	Select PRINTERS.	A list of defined printers comes up.
13.	Press <b>&lt;Insert&gt;</b> to add a printer to the list.	Prompts you for the printer name, type, and some additional fields.
14.	Type in the name of one of the eight default destinations on the unit for the <b>Name</b> field (e.g. d1prn, d2prn, etc.) and go to the <b>Type</b> field.	Cursor moves to this field.

## Chapter 5 Configuring The Internal Ethernet Adapter For Novell

Table 13. PSERVER Setup (NetWare 4) (continued)

Step	Action	Result of Action
15.	Press <b>&lt;Enter&gt;</b> at this field and then select DEFINED ELSEWHERE. If DEFINED ELSEWHERE is not available, choose PARALLEL.	Brings you back to the printer's window.
16.	Press <b>&lt;Enter&gt;</b> on the <b>Print Queues Assigned</b> field.	List of available queues is displayed.
17.	Press <b>&lt;Insert&gt;</b> to display all queues; select the one you defined earlier and press <b>&lt;Enter&gt;</b> .	You are prompted for a priority.
18.	Select a priority and press <b>&lt;Enter&gt;</b> . Priority 1 should be sufficient.	Printer's window displays with fields now filled in.
19.	Press <b>&lt;Escape&gt;</b> until you are back to Main Menu.	Main Menu is displayed.
20.	Reboot the Print Server by unplugging and then plugging it back in.	Unit resets and realizes its new configuration. It then attaches to the queue after 30 seconds or so.
21.	Check the CURRENTLY ATTACHED SERVERS once you have gone into view the appropriate.	You should see the Internal Ethernet Adapter's name displayed (e.g. M_000BF5).
22.	Press <b>&lt;Escape&gt;</b> until you are out of PCONSOLE.	Returns you to the command line. The Internal Ethernet Adapter is configured.

## Configuring the Internal Ethernet Adapter for Windows

---

This section discusses the Internal Ethernet Adapter's support for Windows. The Internal Ethernet Adapter provides support for Windows NT<sup>®</sup>, Windows for Workgroups (WfW), and Windows 95<sup>®</sup>. Examples are provided for each of these environments.

In a Windows environment, TCP/IP is the data transfer protocol used for printing. This means that IP addresses and netmasks are required in your Windows stations along with appropriate TCP/IP software. This chapter will also discuss how you set this up in your environment.

### Print Methods Overview

---

#### A Central Host

The recommended print method for a Windows environment is to have a central host act as a spooler for jobs before they are sent to the Print Server/printer. The reason for this is that the central workstation has the ability to store the spooled jobs while they are waiting to go to the Print Server/printer.

An example of this setup would be a Windows NT host which allows WfW stations to spool to it. The NT host would have the only print setup going to the Print Server/printer directly and it would be shared across the network. In this way, the WfW station could send jobs to this shared printer on the NT host. All WfW jobs would first spool to the NT host before being sent to the Print Server/printer for printing.

#### Print Setup Possibilities

There are two print methods available with the Internal Ethernet Adapter in a Windows environment:

- **LPR** - Berkeley's Line Printer Protocol which uses TCP/IP to transfer data to the Print Server's built-in Line Printer Daemon.
- **NetBIOS** - NetBIOS over TCP/IP used to transfer data to the Internal Ethernet Adapter.

**NetBIOS** is further broken down into these two setup procedures:

- **"net use"** - Microsoft's shared resource feature.
- **Print Manager** - Microsoft's management tool for printing.

## Chapter 5 Configuring the Internal Ethernet Adapter for Windows

---

Your choice depends entirely on what is available with your particular Windows software. The following is a list of what is supported in each:

- **Windows NT and NT/AS** - LPR and NetBIOS (“net use” and Print Manager)
- **Windows for Workgroups** - NetBIOS (“net use” and Print Manager)
- **Windows 95** - NetBIOS (Print Manager)

**NOTE:** Regardless of which method you choose, TCP/IP will always be used in some manner.

### Basic Setup Steps

In each of these environments, the basic setup steps required to get you printing from one of these hosts are to:

1. Ensure that you have the appropriate network software installed on your Windows host.
2. Configure the Windows host with an IP address and netmask.
3. Configure the Internal Ethernet Adapter with an IP address and netmask.
4. Create a printer and select a method of printing to the Print Server (e.g. LPR).

### TCP/IP Setup

---

The following section gives step-by-step directions on how to install the necessary network software in the supported environments.

#### Windows NT LPR Network Software Installation

1. Go to the **Main** program.
2. Double click on **Control Panel**.
3. Double click on **Network**.
4. A dialogue box will appear showing your current network settings. Under **Installed Network Software**, check to see if **MS TCP/IP Printing** shows. If it doesn't, you'll need to perform the following steps.



5. Select **Add New Software**.
6. Select **TCP/IP Protocol and Components**.
7. Click on **Continue**.
8. Select **TCP/IP Printing Support** from the TCP/IP components list that displays. You may also want to select **Connectivity Utilities**.
9. Click on **Continue**.

### Windows NT NetBIOS Network Software Installation

1. Go to the **Main** program group.
2. Double click on **Control Panel**.
3. Double click on **Network**.
4. A dialogue box will appear showing your current network setting. Under **Installed Network Software**, check to see if **NetBIOS TCP/IP->Streams Environment** appears. If not, you'll need to add this new software by clicking on the **Add New Software** Button.

### Windows for Workgroups NetBIOS Software Installation

1. Make sure that you have the Microsoft TCP/IP-32 group in your **Program Manager**. If you do not have the file, wfw32.exe, you can download it from:
  - Compuserve in "MS Software Library"
2. Once this is placed in a directory on your WfW station, you will need to double click on the **Network Setup** icon in the Network Group.
3. Click on **Drivers**.
4. Since the TCP/IP services will not yet be listed here, click on **Add Protocols**.
5. Select **Unlisted**.
6. Specify the directory where the file exists. A new **TCP/IP-32** program group will then be created which will include FTP, Telnet, etc.

**NOTE:** At this point, you will be prompted with a dialogue box asking for the TCP/IP network settings (i.e. IP address and netmask) for this WfW station. Fill these in at this time.

### Windows 95 NetBIOS Network Software Installation

Make sure that **File and Printer Sharing for Microsoft Networks** is installed in your Network setup. If not, you'll need to perform the following steps.

1. Open **Settings:Control Panel** folder.
2. Double click on the **Network** icon.
3. Select **Add**.
4. Select **Service**.
5. Select **File and Printer Sharing for Microsoft Networks** from the list.
6. Click **OK**.
7. Click **OK** again since this service will now show in the list to the left.

### Configuring TCP/IP

---

Since TCP/IP is used as the data transfer protocol, IP addresses and netmasks must be assigned to your Windows workstation(s) if you have not already done so.

If you are not familiar with IP addresses and are sure that this network will not go onto the Internet, [Table 14](#) lists some sample settings to use.

**Table 14. IP Address Examples**

	IP Address	Netmask
Host 1	192.1.1.1	255.255.255.0
M205/M206	192.1.1.2	255.255.255.0
Host 2	192.1.1.3	255.255.255.0
and so on ...		

The following sections will detail how you configure TCP/IP settings on the different Windows platforms.

### Windows NT IP Address and Netmask Configuration

1. Go to the **Main** program group.
2. Double click on **Control Panel**.
3. Double click on **Network**.
4. Select **TCP/IP Protocol** from **Installed Network Software** list.
5. Click on the **Configure** button.
6. A dialogue box will come up asking for network settings. Fill in the IP address and netmask for this workstation and then click OK.

### Windows for Workgroups IP Address and Netmask Configuration

Configuring an IP address and netmask for the WfW workstation is part of the procedure involved in installing NetBIOS Network Software. Please see "NetBIOS Using Print Manager Method" on [page 191](#) for more details.

### Windows 95 IP Address and Netmask Configuration

1. Open the **Settings:Control Panel** folder.
2. Double click on the **Network** icon.
3. Under the **Installed Network Software** list, select the entry dealing with the **TCP/IP Protocol**.
4. Click on **Configure**.
5. A dialogue box will come up asking for network settings. Fill in the IP address and netmask for this workstation and then click **OK**.

### Internal Ethernet Adapter IP Address and Netmask Configuration

Since TCP/IP is being utilized, the Internal Ethernet Adapter's configuration involves storing an IP address and a netmask. To configure the Internal Ethernet Adapter with its network settings, follow the steps below:

1. Find the Ethernet address for the Internal Ethernet Adapter on the bottom of the unit. It must be entered as part of this procedure.
2. Select an IP address for the Internal Ethernet Adapter.
3. Open a DOS window.
4. Use the arp command to add an entry to the host's arp table.  
`arp -s ipaddress ethernetaddress`
5. telnet to the Print Server. This will bring up a login screen.  
`telnet ipaddress`
6. Log into the unit as **root**.
7. At the password prompt, press **<Enter>**. No password is required at this point as the Internal Ethernet Adapter is still unconfigured.

**NOTE:** The following WARNING message will appear. It is not important at this time:

STORED AND CURRENT VALUES DIFFER

You should now see a prompt displayed that has the Internal Ethernet Adapter's IP address followed by a colon, then root.

```
ipaddress:root>
```

8. Store the new IP address and netmask in EEPROM so that the Internal Ethernet Adapter can remember its configuration after reboots. Enter:

```
store net ifnum addr ipaddress  
store net ifnum mask netmask
```

**NOTE:** The *ifnum* will always be (1) since there is only one network interface, ethernet.

9. Verify the IP address and netmask. Enter:

```
list stored net
```

10. Log out of the Telnet session with **quit**. Then reboot the Internal Ethernet Adapter by powering the unit off, then on. This will reset the unit and apply the changes to the stored settings.

11. Test the equipment and configuration after installation is complete.

Enter at the shell prompt:

```
ping ipaddress
```

Once you have configured this unit, you will notice the STAT LED flashing. This means the Internal Ethernet Adapter is configured and recognizable on the network. At this point, you can now configure your host.

## Host Configuration

---

Now that your workstation(s) and the Internal Ethernet Adapter have IP addresses and netmasks, you can now configure a print setup. There are several methods available depending on what Windows package you are using.

### Windows NT Version 3.5x

#### LPR Method

1. Create a print path and printer; select **Main**.
2. Select **Control Panel**.
3. Select **Printers** which loads up the **Print Manager**.
4. Select **Create a Printer** from the **Printer** menu.
5. Define the printer name and driver; in the **Print to** field, select **Other....**
6. Choose **LPR port** from the list that comes up and select **OK**.
7. Fill in the host name or IP address of the Internal Ethernet Address.
8. Fill in the **destination** or queue on the Internal Ethernet Adapter (e.g. d1prn) and select **OK**.

where:

**destination** Is a pre-defined destination or queue on the Internal Ethernet Adapter that is automatically mapped by default to the I/O port. Please note that destinations are case sensitive and are lowercase by default.

This printer is now available for printing and will interact with the Internal Ethernet Adapter's built in Line Printer Daemon using TCP/IP.

### NetBIOS Using Print Manager Method

**NOTE:** In order to use this method, you must first configure the Internal Ethernet Adapter with a Microsoft Networks Workgroup name. This can be done by telneting to the Internal Ethernet Adapter, starting an **nps** session with the unit, and issuing the following command:

```
store pserver smb workgrp workgroupname
```

where ***workgroupname*** is the name of the Microsoft Networks Workgroup that you want the Internal Ethernet Adapter to be included (e.g. **Engineering**).

**NOTE:** You must reset the Internal Ethernet Adapter for this command to take affect.

1. Ensure that the network connection is functioning properly between the Windows NT workstation and the Internal Ethernet Adapter. Try to ping or telnet to the unit.
2. Open **Print Manager**.
3. Select **Connect Network Printer** from the **Printer** menu or click on the appropriate toolbar item.
4. A list of network services will appear. Double click on the **Microsoft Windows Network**.
5. A list of known workgroups will appear. Double click on the workgroup name that you previously configured the Internal Ethernet Adapter under (e.g. Engineering).
6. Double click on the Internal Ethernet Adapter once the list of registered devices in this workgroup appears.
7. A list of destinations (e.g. d1prn) with NetBIOS service enabled will appear. These are read directly from the Internal Ethernet Adapter. Select one of them.
8. Print Manager will then ask to install a local printer driver. Click on **OK**.
9. A dialogue box appears providing a list of possible printer drivers. Once you select one, click on **OK**.

The printer is now available for printing using NetBIOS over TCP/IP.

### Windows for Workgroups

### NetBIOS Using Print Manager Method

**NOTE:** In order to use this method, you must first configure the Internal Ethernet Adapter with a Microsoft Networks Workgroup name. This can be done by telneting to the Internal Ethernet Adapter, starting an **nps** session with the unit, and issuing the following command.

```
store pserver smb workgrp workgroupname
```

where ***workgroupname*** is the name of the Microsoft Networks Workgroup that you want the Internal Ethernet Adapter to be included (e.g. **Engineering**).

**NOTE:** You must reset the Internal Ethernet Adapter for this command to take affect.

1. Ensure that the network connection is functioning properly between the Windows workstations and the Internal Ethernet Adapter. Try to ping or telnet to the unit.
2. Open **Print Manager**.
3. Select **Connect Network Printer** from the **Printer menu** or click on the appropriate toolbar item.
4. A list of known workgroups will appear. Double click on the workgroup name that you previously configured the Internal Ethernet Adapter under (e.g. Engineering).
5. Double click on the Internal Ethernet Adapter once the list of registered devices in this workgroup appears.
6. A list of destinations (e.g. d1prn) with NetBIOS service enabled will appear. These are read directly from the Internal Ethernet Provider. Select one of them.
7. Click **OK**.

This printer is now available for printing using NetBIOS over TCP/IP.

## Windows 95

### NetBIOS Using Print Manager Method

**NOTE:** This setup assumes that you have already created a local printer using the **Add a New Printer** icon in the **Settings:Printer** folder. You can use any port here such as LPT1 or LPT2 when creating this printer.

**NOTE:** In order to use this method, you must first configure the Internal Ethernet Adapter with a Microsoft Networks Workgroup name. This can be done by telneting to the Internal Ethernet Adapter, starting an **nps** session with the unit, and issuing the following command:

```
store pserver smb workgrp workgroupname
```

where *workgroupname* is the name of the Microsoft Networks Workgroup that you want the Internal Ethernet Adapter to be included (e.g. **Engineering**).

**NOTE:** You must power the printer down and then up again for the Internal Ethernet Adapter command to take affect.

1. Ensure that the network connection is functioning properly between the Windows workstations and the Internal Ethernet Adapter. Try to ping or telnet to the unit.
2. Open the **Settings:Printer** folder.
3. Double click on the target printer that you created earlier.
4. Select **Properties** from the Printer menu.
5. Select the **Details** tab and click on the **Add Port...** button.
6. Select the **Browse** button.
7. A list of network services will appear. Double click on the **Entire Network**.
8. A list of known workgroup will appear. Double click on the workgroup name that you previously configured the Internal Ethernet Adapter under (e.g. Engineering).
9. Double click on the Internal Ethernet Adapter once the list of registered devices in this workgroup appears.



## Host Configuration

---

10. A list of destinations (e.g. d1prn) with NetBIOS service enabled will appear. These are read directly from the Internal Ethernet Adapter. Select one of them.
11. Click on **OK** to exit the **Browse for Printer** dialogue box.
12. Click on **OK** to exit the **Properties** dialogue box.

This printer is now available for printing using NetBIOS over TCP/IP.

**Chapter 5** Configuring the Internal Ethernet Adapter for Windows

---

---

# 6

## *Troubleshooting*

---

### **Cleaning Requirements**

---

Clean the printer every six months or after every 1000 hours of operation, whichever occurs first. If the printer is located in a dusty area or is used for heavy duty printing, clean it more often.

**WARNING**    **Disconnect the power source before cleaning the printer.**

**WARNUNG**    **Vor dem Säubern des Druckers ist die Netzverbindung zu unterbrechen.**

**ATTENTION**    **Débranchez l'alimentation avant de nettoyer l'imprimante.**

### **Exterior Cleaning**

---

Clean the outside of the cabinet with a soft, lint-free cloth and mild detergent soap. (Dishwashing liquid works well.) Do not use abrasive powders or chemical solvents. Clean the windows with plain water or mild window cleaner. Always apply the cleaning solution to the cloth; never pour cleaning solution directly onto the printer.

## Interior Cleaning

Over time, particles of paper and ink accumulate inside impact printers. This is normal. Paper dust and ink build-up must be periodically removed to avoid degraded print quality. Most paper dust accumulates around the ends of the platen and ribbon path.

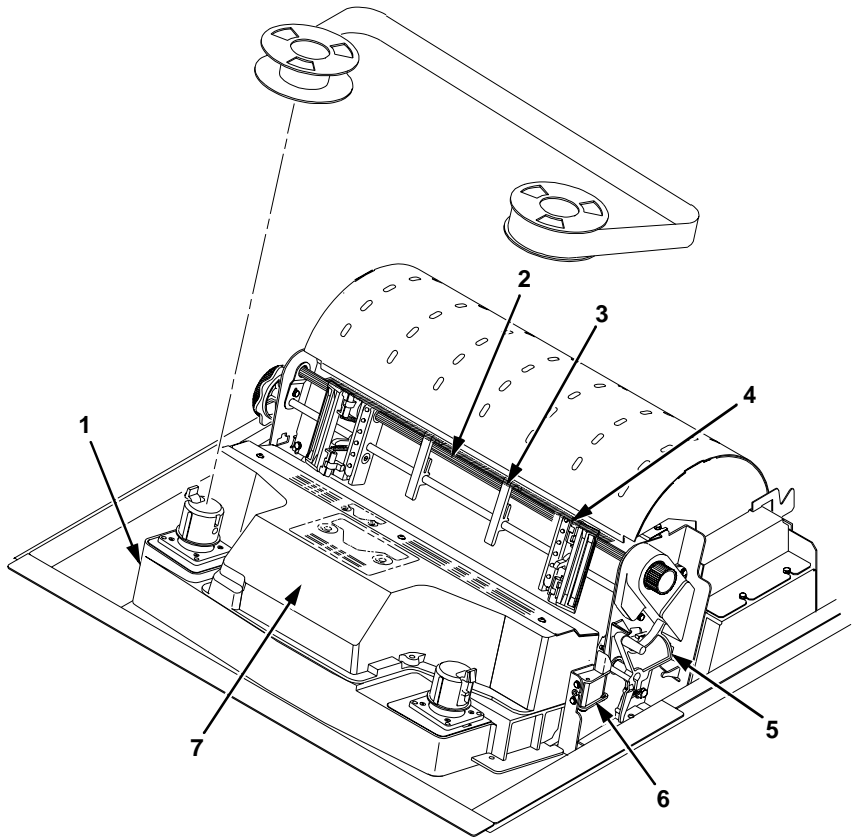

**Legend:**

- 1) Base Casting
- 2) Splined Shaft
- 3) Paper Support (2)
- 4) Tractor
- 5) Forms Thickness Lever
- 6) Ribbon Guide (2)
- 7) Shuttle Cover Assembly

## Interior Cleaning

---

To clean the interior of the printer perform the following steps.

1. Power off the printer and unplug the printer power cord.
2. Open the printer cover. Fully raise the forms thickness lever. Unload paper.
3. Unlatch both ribbon spools and carefully lift them off the hubs. Raise the ribbon out of the ribbon path.
4. Using a soft-bristled, non-metallic brush (such as a toothbrush), brush paper dust and ribbon lint off the tractors, shuttle cover assembly, base casting, and ribbon guides. Vacuum up the residue.

**CAUTION** Vacuum carefully around the hammer bank and surrounding area to avoid damage. To avoid corrosion damage, use only alcohol when cleaning the printer mechanical elements. Solutions used to clean mechanical elements must contain no water.

5. Wipe the splined shaft with a soft cloth.
6. Check the ribbon mask and hammer bank cover for bits of torn paper or ribbon lint.
7. Using a soft cloth lightly moistened with anhydrous alcohol, remove dust and ink from the platen. (The platen is the thick silver bar behind the hammer bank cover that rotates when the forms thickness lever is rotated.) Clean the ribbon guides.
8. Brush and vacuum up dust or residue that has accumulated inside the lower cabinet.
9. Wipe the lower cabinet interior with a clean, lint-free cloth dampened (not wet) with water and mild detergent or window cleaning solution. Dry the lower cabinet interior by wiping it down with a clean, lint-free cloth.
10. Install the ribbon and load paper.

## Diagnosing Problems

---

This section is designed to help the user recover from any problems which may arise with normal printer operation.

### Printing a Hex Dump

---

A hex code printout (or hex dump) is a translation of all host interface data to its hexadecimal equivalent, listing all ASCII character data received from the host computer with their corresponding two-digit hexadecimal codes. Hex dumps are used to troubleshoot printer data reception problems.

Printable characters print as the assigned symbol; nonprintable characters are indicated by a period (.).

For instructions on how to enable and disable Hex Dump mode, see [page 112](#). [Figure 15](#) shows an example of a hex dump.

## Printing a Hex Dump

```

!##%&'()*+,-./ 20 21 22 23 24 25 26 27 28 29 2A 2B 2C 2D 2E 2F
0123456789:;<=>? 30 31 32 33 34 35 36 37 38 39 3A 3B 3C 3D 3E 3F
@ABCDEFGHIJKLMNO 40 41 42 43 44 45 46 47 48 49 4A 4B 4C 4D 4E 4F
PQRSTUVWXYZ[\]^_ 50 51 52 53 54 55 56 57 58 59 5A 5B 5C 5D 5E 5F
`abcdefgijklmno 60 61 62 63 64 65 66 67 68 69 6A 6B 6C 6D 6E 6F
pqrstuvwxyz{|}~ 70 71 72 73 74 75 76 77 78 79 7A 7B 7C 7D 7E 20
!##%&'()*+,-./0 21 22 23 24 25 26 27 28 29 2A 2B 2C 2D 2E 2F 30
123456789:;<=>@ 31 32 33 34 35 36 37 38 39 3A 3B 3C 3D 3E 3F 40
ABCDEFGHIJ...!##%& 41 42 43 44 45 46 47 48 0D 0A 21 22 23 24 25 26
'()*+,-./0123456 27 28 29 2A 2B 2C 2D 2E 2F 30 31 32 33 34 35 36
789:;<=>@ABCDEF 37 38 39 3A 3B 3C 3D 3E 3F 40 41 42 43 44 45 46
GHIJKLMNQRSTU 47 48 49 4A 4B 4C 4D 4E 4F 50 51 52 53 54 55 56
WXYZ[\]^_`abcd 57 58 59 5A 5B 5C 5D 5E 5F 60 61 62 63 64 65 66
ghijklmnopqrst 67 68 69 6A 6B 6C 6D 6E 6F 70 71 72 73 74 75 76
vwxyz{|}~!##%&' 77 78 79 7A 7B 7C 7D 7E 20 21 22 23 24 25 26 27
'()*+,-./0123456 28 29 2A 2B 2C 2D 2E 2F 30 31 32 33 34 35 36 37
89:;<=>@ABCDEFG 38 39 3A 3B 3C 3D 3E 3F 40 41 42 43 44 45 46 47
HI...!##%&'()*+,- 48 49 0D 0A 22 23 24 25 26 27 28 29 2A 2B 2C 2D
./0123456789:;<= 2E 2F 30 31 32 33 34 35 36 37 38 39 3A 3B 3C 3D
>?@ABCDEFGHIJKL 3E 3F 40 41 42 43 44 45 46 47 48 49 4A 4B 4C 4D
NDPQRSTUVWXYZ[\ 4E 4F 50 51 52 53 54 55 56 57 58 59 5A 5B 5C 5D
^_`abcdefgijklm 5E 5F 60 61 62 63 64 65 66 67 68 69 6A 6B 6C 6D
nopqrstuvwxyz{|} 6E 6F 70 71 72 73 74 75 76 77 78 79 7A 7B 7C 7D
~!##%&'()*+,-. 7E 20 21 22 23 24 25 26 27 28 29 2A 2B 2C 2D 2E
/0123456789:;<=> 2F 30 31 32 33 34 35 36 37 38 39 3A 3B 3C 3D 3E
?@ABCDEFGHIJ...## 3F 40 41 42 43 44 45 46 47 48 49 4A 0D 0A 23 24
%&'()*+,-./01234 25 26 27 28 29 2A 2B 2C 2D 2E 2F 30 31 32 33 34
56789:;<=>@ABCD 35 36 37 38 39 3A 3B 3C 3D 3E 3F 40 41 42 43 44
EFGHIJKLMNQRST 45 46 47 48 49 4A 4B 4C 4D 4E 4F 50 51 52 53 54
UVWXYZ[\]^_`abcd 55 56 57 58 59 5A 5B 5C 5D 5E 5F 60 61 62 63 64
efghijklmnopqrst 65 66 67 68 69 6A 6B 6C 6D 6E 6F 70 71 72 73 74
uvwxyz{|}~!##% 75 76 77 78 79 7A 7B 7C 7D 7E 20 21 22 23 24 25
&'()*+,-./012345 26 27 28 29 2A 2B 2C 2D 2E 2F 30 31 32 33 34 35
6789:;<=>@ABCDE 36 37 38 39 3A 3B 3C 3D 3E 3F 40 41 42 43 44 45
FGHIJK...%&'()*+ 46 47 48 49 4A 4B 0D 0A 24 25 26 27 28 29 2A 2B
,-./0123456789: 2C 2D 2E 2F 30 31 32 33 34 35 36 37 38 39 3A 3B
<=>?@ABCDEFGHIJK 3C 3D 3E 3F 40 41 42 43 44 45 46 47 48 49 4A 4B
LMNOPQRSTUVWXYZ 4C 4D 4E 4F 50 51 52 53 54 55 56 57 58 59 5A 5B
\]^_`abcdefgijkl 5C 5D 5E 5F 60 61 62 63 64 65 66 67 68 69 6A 6B
lmnopqrstuvwxyz{ 6C 6D 6E 6F 70 71 72 73 74 75 76 77 78 79 7A 7B
}|}~!##%&'()*+ 7C 7D 7E 20 21 22 23 24 25 26 27 28 29 2A 2B 2C

```

Figure 15. Hex Dump Sample

## Fault Messages

---

If a fault condition occurs in the printer, the status indicator on the control panel flashes on and off and the message display indicates the specific fault. Fault messages are summarized in [Table 15](#).

Displayed faults fall into one of two categories:

- Operator correctable
- Field service required

For the operator-correctable faults, follow the suggested solution in [Table 15](#). After correcting the displayed fault, press the CLEAR key to clear the error message and status indicator and resume printing. If the fault message reappears, contact your authorized service representative.

**NOTE:** The *Maintenance Manual* provides more detailed information and procedures for resolving fault conditions. However, many of the procedures described there must be performed only by your authorized service representative.

### Fault Messages Requiring Field Service Attention

If a fault is not correctable by the operator, the fault message is followed by an asterisk (\*). This usually indicates that an authorized service representative is needed. You may try two steps to clear the fault before calling your authorized service representative:

1. Set the printer power switch to O (off), wait 15 seconds, then turn the printer on again. Run your print job again. If the message does not appear, it was a false indication and no further attention is required.
2. If the message reappears, press the CLEAR key. If the message goes away, it was a false indication and no further attention is required. If the message reappears, call your authorized service representative.



## Fault Messages

**Table 15. LCD Message Troubleshooting Table**

Displayed Message	Can User Correct?	Explanation	Solution
8.5V PWR FAIL*	No	Internal power failure.	Contact your authorized service representative. <sup>1</sup>
15V CTL FAIL*	No	Controller voltage failure.	Contact your authorized service representative. <sup>1</sup>
23.5V CTL FAIL*	No	Controller voltage failure.	Contact your authorized service representative. <sup>1</sup>
48V PWR FAIL*	No	Internal power failure.	Contact your authorized service representative. <sup>1</sup>
ACCESS NULL PTR*	No	Fatal firmware error on controller board.	Contact your authorized service representative. <sup>1</sup>
A TO D OVERUN*	No	Fatal firmware error on controller board.	Contact your authorized service representative. <sup>1</sup>
BUFFER OVERFLOW	Yes	Host sends data after the printer buffer is full (serial interface).	Check your serial host interface parameter settings; if necessary, adjust them so that they match the settings of the attached host.
BUFFER OVERRUN	Yes	Receive overrun (serial interface).	Check printer serial port configuration setup. Ensure the baud rate and data protocol match both host and printer settings.
CAUTION PPM HAS REMOTE CONTROL	Yes	Another user is accessing the printer remotely through the Printer Manager.	Wait until the remote user has finished their Printer Manager session, or press any key to disable the Printer Manager and gain control of the printer.
CLEAR PAPER JAM	Yes	No paper motion.	Clear jam and reload paper. If this message recurs, contact your authorized service representative. <sup>1</sup>
CLOSE PLATEN	Yes	The forms thickness lever is open.	Close the forms thickness lever.

## Chapter 6 Diagnosing Problems

**Table 15. LCD Message Troubleshooting Table (continued)**

COIL HOT	Yes	One or more hammer coils are hot.	Check printer environment. If too hot or dusty, relocate printer. May occur normally on graphically intense print jobs.
CTL VOLT FAIL*	No	Controller voltage failure.	Contact your authorized service representative. <sup>1</sup>
DRVR CIR BAD*	No	Hammer coil count test failed.	Contact your authorized service representative. <sup>1</sup>
EXHAUST FAN FLT (Cabinet model only)	Yes	Sensors cannot detect current in fan circuit.	Power off the printer and remove the paper path (see <i>Maintenance Manual</i> ). Check that the fan cable connector is connected. Check for obstruction of vents and fan airway, and remove any obstructions. Check for items beneath the printer blocking cabinet vents. Power back on the printer. If this message recurs, contact your authorized service representative. <sup>1</sup>
FIRMWARE ERROR*	No	Application software tried to perform an illegal printer function or damaged memory detected on board.	Contact your authorized service representative. <sup>1</sup>
FRAMING ERROR	Yes	Serial framing error (serial interface).	Check your serial host interface parameter settings; if necessary, adjust them so that they match the settings of the attached host.
HAM. COIL OPEN*	No	Electrical malfunction of one or more hammer coils.	Contact your authorized service representative. <sup>1</sup>
HAMMER COIL BAD* #, #, #	No	Hammer coil # failed current test at power up.	Contact your authorized service representative. <sup>1</sup>

## Fault Messages

**Table 15. LCD Message Troubleshooting Table (continued)**

HMR BANK FAN FLT	Yes	Sensors cannot detect current in fan circuit.	Check that fan cable is connected. Check for obstruction of vents and fan airway; remove any obstructions. Check for items beneath the printer blocking cabinet vents. Power back on the printer. If this message recurs, contact your authorized service representative. <sup>1</sup>
HB NOT INSTALLD*	No	Self-test does not detect hammer coils.	Contact your authorized service representative. <sup>1</sup>
ILL EXT BUS ACC*	No	Fatal firmware error on controller board.	Contact your authorized service representative. <sup>1</sup>
ILLGL OPR ACCSS*	No	Fatal firmware error on controller board.	Contact your authorized service representative. <sup>1</sup>
ILL INST ACCSS*	No	Fatal firmware error on controller board.	Contact your authorized service representative. <sup>1</sup>
INTAKE FAN FAULT	Yes	Sensors cannot detect current in fan circuit.	See description for HMR BANK FAN FLT.
LO DRV. SHORT *	No	Circuit(s) on the hammer bank or in the hammer bank power cable shorted to ground.	Contact your authorized service representative. <sup>1</sup>
LOAD PAPER	Yes	Printer is out of paper.	Load paper.
ONLINE 8344 FAILED*	No	Link-level code test detects hardware failure.	Contact your authorized service representative. <sup>1</sup>
PAP BAD TABLE*	No	Fatal firmware error on controller board.	Contact your authorized service representative. <sup>1</sup>
PAP BSY TOO LNG*	No	Fatal firmware error on controller board.	Contact authorized service representative. <sup>1</sup>
PAP FIFO OVERFL*	No	Fatal firmware error on controller board.	Contact your authorized service representative. <sup>1</sup>
PAP FIFO UNDRFL*	No	Fatal firmware error on controller board.	Contact your authorized service representative. <sup>1</sup>

## Chapter 6 Diagnosing Problems

**Table 15. LCD Message Troubleshooting Table (continued)**

PAP ILLGL ST*	No	Fatal firmware error on controller board.	Contact your authorized service representative. <sup>1</sup>
PAP INCMPL ENER*	No	Fatal firmware error on controller board.	Contact your authorized service representative. <sup>1</sup>
PAP INVLD CMD*	No	Fatal firmware error on controller board.	Contact your authorized service representative. <sup>1</sup>
PAP INVLD PARM*	No	Fatal firmware error on controller board.	Contact your authorized service representative. <sup>1</sup>
PAP NOT SCHED*	No	Fatal firmware error on controller board.	Contact your authorized service representative. <sup>1</sup>
PAP NT AT SPEED*	No	Fatal firmware error on controller board.	Contact your authorized service representative. <sup>1</sup>
PAP UNEXP INT*	No	Fatal firmware error on controller board.	Contact your authorized service representative. <sup>1</sup>
PARITY ERROR	Yes	Parity error (serial interface)	Check your serial host interface parameter settings; if necessary, adjust them so that they match the settings of the attached host.
POWER SUPPLY HOT	Yes	Power supply sensors report high temperatures.	Check printer environment. If hot or dusty, relocate printer. Contact your authorized service representative if this occurs frequently. <sup>1</sup>
PROTECTED INSTR*	No	Fatal firmware error on controller board.	Contact your authorized service representative. <sup>1</sup>
PLAT INV PARM*	No	Fatal firmware error on controller board.	Contact your authorized service representative. <sup>1</sup>
PLAT INV CMD*	No	Fatal firmware error on controller board.	Contact your authorized service representative. <sup>1</sup>
PLAT INV STATE*	No	Fatal firmware error on controller board.	Contact your authorized service representative. <sup>1</sup>

## Fault Messages

**Table 15. LCD Message Troubleshooting Table (continued)**

POWER SAVER MODE	N/A	Status message: printer is in low-energy idle state, all fans and higher voltages are off, only +5Vdc logic circuits are active.	No action required.
PRINTER HOT	Yes	Controller board sensors report high temperatures on the board.	Check printer environment. If hot or dusty, relocate printer. Contact your authorized service representative if this occurs frequently. <sup>1</sup>
PWR SUPP VOLT *	No	Power supply failed.	Replace power supply board.
RIB INVLD STATE*	No	Fatal firmware error on controller board.	Contact your authorized service representative. <sup>1</sup>
RIBBON DRIVE*	No	CMX controller does not detect ribbon drive motor.	Contact your authorized service representative. <sup>1</sup>
RIBBON INK OUT CHANGE RIBBON	Yes	The RibbonMinder program is warning that the amount of ink in the ribbon has reached 0%.	Replace ribbon or press CLEAR for two additional minutes of printing before the fault displays again. See "RIBBONMINDER" on <a href="#">page 128</a> .
RIB INVLD CMD*	No	Fatal firmware error on controller board.	Contact your authorized service representative. <sup>1</sup>
SECURITY CODE VIOLATION*	No	Security code of PAL on controller board does not match code of firmware on the controller board.	Contact your authorized service representative. <sup>1</sup>
SHUTL INV CMD*	No	Fatal firmware error on controller board.	Contact your authorized service representative. <sup>1</sup>
SHUTL INV PARM*	No	Fatal firmware error on controller board.	Contact your authorized service representative. <sup>1</sup>
SHUTTLE JAM	Yes	No shuttle movement or shuttle moving at wrong speed.	Check for obstruction to shuttle, a twisted ribbon, or forms thickness lever closed too tightly. If fault source is not apparent, contact your authorized service representative.

## Chapter 6 Diagnosing Problems

---

**Table 15. LCD Message Troubleshooting Table (continued)**

SOFTWARE ERROR *	No	Application software tried to perform illegal printer function, or damaged logic circuits found on controller board.	Contact your authorized service representative. <sup>1</sup>
STACK OVERFLOW*	No	Fatal firmware error on controller board.	Contact your authorized service representative. <sup>1</sup>
TCB CORRUPTED*	No	Fatal firmware error on controller board.	Contact your authorized service representative. <sup>1</sup>
UNDEF INTERRUPT*	No	Fatal firmware error on controller board.	Contact your authorized service representative. <sup>1</sup>
UNDFNED OPCODE*	No	Fatal firmware error on controller board.	Contact your authorized service representative. <sup>1</sup>
UP DRV. SHORT*	No	Hammer drive circuits on the boards shorted to ground.	Contact your authorized service representative. <sup>1</sup>
<sup>1</sup> Before contacting an authorized service representative, power off the printer, wait 15 seconds, then power it back on and rerun your print job. If the message reappears, press CLEAR. If the fault message still displays, then contact your authorized service representative.			

---



## *Printer Specifications*

### **Ribbon Specifications**

---

Extended Life Text Ribbon Kit (60 yards)	P/N 55R034
Extended Life Text Ribbon Kit (100 yards)	P/N 55R036
Bar Code Ribbon Kit (60 yards)	P/N 55R035
Bar Code Ribbon Kit (100 yards)	P/N 55R037

**NOTE:** Only cabinet models support 100-yard ribbons. Pedestal models must use 60-yard ribbons. Each kit contains six ribbons.

## **Paper Specifications**

---

Type:	Edge-perforated, fan-fold, 3 to 17 inches (7.62 to 43.18 cm) wide, 2 to 16 inches (5.08 to 40.64 cm) long.
Thickness:	Single-part: 15 to 100 pound (6.80 to 45.36 kg) stock; Multi-part: 1- to 6-part forms (maximum 12 lb [5.44 kg] ply of upper plies)
Sheet Thickness:	0.025 inch (0.064 cm) maximum
Drive:	Adjustable tractors (6-pin engagement)

### **Labels**

On Backing:	One-part continuous perforated fanfold back form. Labels must be placed at least 1/6 inch (0.42 cm) from the fan-fold perforation. Backing adhesive must not be squeezed out during printing.
Sheet Size:	3 to 17 inches (7.62 to 43.18 cm) wide, including the two standard perforated tractor feed strips. A maximum sheet length of 16 inches (40.64 cm) between top and bottom perforations.
Thickness:	Not to exceed 0.025 inch (0.064 cm) (including backing sheet)



---

## Printer Dimensions

---

### **Cabinet Model:**

Height:	42.5 inches (108 cm)
Width:	27 inches (68.6 cm)
Depth:	29 inches (73.7 cm)
Weight:	225 lbs. (102.1 kg) unpackaged 285 lbs. (129.3 kg) packaged

### **Pedestal Model:**

Height:	35 inches (88.9 cm)
Width:	24.6 inches (62.5 cm)
Depth:	20.7 inches (52.6 cm)
Weight:	105 lbs. (47.6 kg) unpackaged 115 lbs. (52.2 kg) packaged

## **Environmental Characteristics**

---

### **Temperature:**

Operating:      50° to 104° F (10° to 40° C) up to 5000 feet (1524 meters)  
                         50° to 90° F (10° to 32° C) up to 8000 feet (2438 meters)

Storage:            -40° to 158° F (- 40° to 70° C)

### **Relative Humidity**

Operating:      15% to 80% (noncondensing)

Storage:            15% to 90% (noncondensing)

### **Energy Star**

The printers described in this *User's Manual* comply with the requirements of the ENERGY STAR® Office Equipment Program of the U.S. Environmental Protection Agency.

When in the reduced-power idle state, the printer displays "Power Saver Mode."

---

## Electrical Characteristics

---

### Input Voltage

Line Voltage Design Range	Line Frequency	500/1000 LPM	1500 LPM
88-135 V RMS	47-63 Hz	6A @ 100 V	8A @ 100 V
178-270 V RMS	47-63 Hz	3A @ 200 V	5A @ 200 V

### Power Consumption

Operating Mode	Units	Power Consumption		
		500 LPM	1000 LPM	1500 LPM
Standby <sup>1</sup>	Watts	30 (60)	30 (60)	45 (80)
	BTU/Hour	100 (205)	100 (205)	154 (273)
Nominal <sup>2</sup>	Watts	180	220	310
	BTU/Hour	615	750	1058
Maximum <sup>3</sup>	Watts	270	315	440
	BTU/Hour	920	1075	1500

<sup>1</sup>Numbers represent consumption in Power Saver Mode.  
Numbers in parenthesis represent standby mode.

<sup>2</sup>Nominal power measured at 120 VAC while printing ASCII Shift-Recycle.

<sup>3</sup>Maximum power measured at 120 VAC while printing Black Plot.

## Interfaces

---

Type:	Standard:	IEEE 1284 Parallel, RS-232/RS-422 serial
	Optional:	Dataproducts Long Lines, Ethernet 10Base-T, Ethernet 10Base2.
Logic Levels:		TTL/EIA-232E/EIA-422B
Transfer Rates		Up to 200 Kilobytes on parallel interface. Up to 38.4K baud on RS-232 and RS-422 serial interface.

## Printing Rates

---

The printing speed of text is measured in lines per minute (lpm), and is a function of the selected font and the vertical dot density. Printing speed is independent of the number of characters configured in the character set repertoire. Print rates for lines containing attributes such as bold or emphasized printing, superscripts, subscripts, or elongated attributes will decrease to not less than half the rates of the font without such attributes. The exact print rate of lines containing these attributes depends on the specific print job, but software maximizes the throughput by dynamically determining which dot rows contain adjacent dots and must be printed in two strokes.

The reverse paper feed capability allows the printing of multiple densities on a single line. This is useful in printing forms and text together or in mixing different fonts on a print line. Use of multiple densities and reverse paper feed also affects throughput.

---

# B

## *Downloading Firmware*

---

### Loading Flash Memory

---

Flash memory is contained in in-line memory modules (SIMMs) located on the CMX controller board. (Shown in the *Maintenance Manual*.) Printer emulation and operating system software are loaded into flash memory at the factory, but you will install software in the following situations:

- You buy the IGP/PGL or Code V graphics option after the printer is installed
- You need to upgrade printer software
- You need different emulation software
- You have replaced the controller board

Emulation and operating system software are stored as a compressed file on a 3.5 inch, double-density floppy diskette. The file is “executable”. You will expand it and copy it into printer flash memory with a single command.

1. Make a printout of *all* saved configurations. (Refer to “Print Config.” on [page 72](#).) Installing new software erases all saved configurations. You will use the printouts to restore printer configuration.
2. Set the printer power switch to O (off).
3. Unplug the AC power cord from the printer.
4. If the printer's parallel data cable is connected to the parallel port of an IBM or IBM-compatible computer using the PC-DOS™, MS-DOS®, Windows® 3.x or Windows 95 operating system, skip to step 8. If not, go to step 5.
5. Disconnect all data input cables from the printer interface.

6. Connect the parallel data cable to the default parallel port (LPT1) of an IBM or IBM-compatible personal computer using the PC-DOS, MS-DOS, Windows 3.x or Windows 95 operating system.

**NOTE:** You can connect the cable to the LPT2 port if the LPT1 port is already in use. You can also download software through the printer serial port. The download commands are different if you use these ports, as described in the note after step 18.

7. Connect the parallel data cable to the parallel port of the printer.
8. Plug the AC power cord into the printer.
9. Power on the host computer.
10. Insert the emulation or upgrade diskette into diskette drive A (or B) of the personal computer.

11. Make the diskette drive the active drive by typing the following at the DOS prompt:

**A:** <Return>

(If the diskette is in drive B, type **B:** <Return>)

12. Get the name of the compressed file on the diskette by listing the contents of the diskette; at the DOS prompt type:

**DIR**<Return>

The compressed file on the diskette takes the form *FILENAME.EXE*. Write down the complete name of the file with the *.EXE* extension.

13. On the printer operator panel, press and hold down the **ON LINE + FF** keys. Without releasing the keys, power the printer on. Continue holding the keys down until "WAITING FOR PROGRAM DOWNLOAD" appears on the LCD.
14. When you see "WAITING FOR PROGRAM DOWNLOAD" on the LCD, release the **ON LINE + FF** keys.

**NOTE:** The default download port is DATAPRODUCTS; this is the standard download through the parallel port. If you want to use the default, continue with step 18.

15. Press the **▶** (NEXT) key; "SELECT DOWNLOAD PORT=DATAPRODUCTS" appears on the LCD.
16. Press **▶** (NEXT) again to cycle through the download ports available in the printer:  
DATAPRODUCTS\*      (parallel) (default port)  
RS232-9600          (RS-232 serial, 9600 baud)  
RS232-19.2K        (RS-232 serial, 19200 baud)

---

RS232-38.4K	(RS-232 serial, 38400 baud)
RS422-9600	(RS-422 serial, 9600 baud)
RS422-19.2K	(RS-422 serial, 19200 baud)
RS422-38.4K	(RS-422 serial, 38400 baud)

17. When the printer download port you want to use is displayed on the LCD, press **ENTER**. "WAITING DOWNLOAD / PORT = *<your selection>*" appears on the display.
18. At the DOS prompt on the computer type:  
**FILENAME.EXE -pb<Return>**  
where *FILENAME.EXE* is the compressed file you noted in step 12. This command decompresses the file on the diskette and copies it as a binary file into the flash memory on the printer controller board.  
**NOTE:** If you are downloading the file using the LPT2 port on the PC, enter the following DOS command:  
**FILENAME.EXE -pb 2 <Return>**  
  
If you are downloading the file into the printer serial port, enter the following DOS commands\*:  
**MODE COM1:9600,N,8,1,P<Return>**  
**FILENAME.EXE -pb c1<Return>**  
\* 9600 is the only rate older versions of DOS can use; otherwise, type the digits corresponding to the rate you selected in step 16.
19. While the file is copied into memory, the printer LCD informs you of the load process and status. (See [Table 16.](#))
20. When the new program has successfully loaded into memory and the printer has reset itself, set the printer power switch to O (off).
21. Unplug the AC power cord from the printer.
22. Remove the diskette from the host computer and store it with the printer.
23. Power off the host computer.
24. If you had to install a parallel data cable to the computer and printer, disconnect it from the computer and printer.
25. Reconnect the data input cable(s) to the printer, if required.
26. Return the printer to normal operation.
27. Using the configuration printout(s) you made in step 1, reconfigure the printer. (Refer to Chapter 4.)

## Appendix B Loading Flash Memory

---

**Table 16. Flash Memory Message Guide**

<b>Message</b>	<b>Explanation</b>	<b>Required Action</b>
CLEARING PROGRAM FROM FLASH	The program successfully loaded into printer RAM and the checksum matched. The old program is now being deleted from flash memory.	None
DIAGNOSTIC PASSED	The printer passed its memory and hardware initialization tests.	None
ERROR: DC PROGRAM NOT VALID	Printer cannot find the data controller program or the validation checksum is corrupt.	Download the program again. If the message occurs again, call your service representative.
ERROR: DRAM AT ADDRESS XXXXXXXX	The printer found a defective memory location.	Call your service representative.
ERROR: EC PROGRAM NOT VALID	Printer cannot find the engine controller program or the validation checksum is corrupt.	Download the program again. If the message occurs again, call your service representative.
ERROR: EC STOPPED AT STATE XXXX	Hardware fault in the engine controller.	Call your service representative.
ERROR: FLASH DID NOT PROGRAM	The printer encountered an error trying to program flash memory.	Download the program again. If the message occurs again, call your service representative.
ERROR: NO DRAM DETECTED	The printer could not find any DRAM.	Call your service representative.



**Table 16. Flash Memory Message Guide (continued)**

<b>Message</b>	<b>Explanation</b>	<b>Required Action</b>
ERROR: FLASH NOT DETECTED	The printer could not find any flash memory.	Call your service representative.
ERROR: NVRAM FAILURE	The security PAL is not present or the non-volatile memory has failed.	Call your service representative.
ERROR: PROGRAM NEEDS MORE DRAM	The printer requires more DRAM memory in order to run the downloaded program.	Add DRAM. Call your service representative.
ERROR: PROGRAM NEEDS MORE FLASH	The printer requires more flash memory in order to run the downloaded program.	Add flash memory. Call your service representative.
ERROR: PROGRAM NOT COMPATIBLE	The printer is not compatible with the downloaded program.	Use the correct emulation software option(s) for this model.
ERROR: PROGRAM NOT VALID	The printer does not see a program in flash memory.	There is no program in printer memory. Download program again.
ERROR: SECURITY PAL NOT DETECTED	The security PAL is not present or has failed.	Call your service representative.
ERROR: SHORT AT ADDRESS XXXX	Hardware failure in DRAM or CMX controller circuitry.	Call your service representative.
ERROR: WRITING TO FLASH	Hardware or software fault in flash memory.	Download the program again. If the message occurs again, call your service representative.

## Appendix B Loading Flash Memory

**Table 16. Flash Memory Message Guide (continued)**

<b>Message</b>	<b>Explanation</b>	<b>Required Action</b>
ERROR: WRONG CHECKSUM	The printer received the complete program but the checksum did not match. The data were corrupted during download.	Download the program again. If the message occurs again, call your service representative.
LOADING PROGRAM FROM PORT XX%	The new program is loading into printer RAM. XX indicates how much of the program has loaded.	None
LOADING PROGRAM INTO FLASH	The printer has deleted the previous program from flash memory and is loading the new program into flash memory.	None
RESETTING . . . PLEASE WAIT	The printer finished loading the program into flash memory and is automatically resetting itself.	None
RESTORING BOOT CODE	Normal download initialization message.	None
SECURITY CODE VIOLATION	The software running or being downloaded does not match the security PAL code.	Call your service representative.
SENDING PROGRAM TO EC PROCESSOR	The printer is loading the engine controller program into the engine controller.	None
TABLE MISMATCH DOWNLOAD AGAIN	EC software update in progress.	Download the program again.

# C

## ASCII Character Set

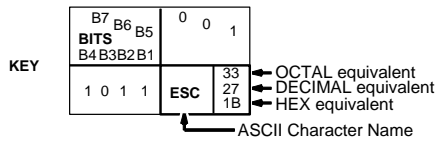

B7 BITS	B6	B5	0 0 0		0 0 1		0 1 0		0 1 1		1 0 0		1 0 1		1 1 0		1 1 1			
			COLUMN 0	1	2	3	4	5	6	7										
B4	B3	B2	B1	ROW	0	1	2	3	4	5	6	7	8	9	10	11	12	13	14	15
0	0	0	0	0	NUL	DLE	SP	0	@	P	\	p	20 16 10	40 32 20	60 48 30	100 64 40	120 80 50	140 96 60	160 112 70	
0	0	0	1	0	SOH	DC1 (XON)	!	1	A	Q	a	q	21 17 11	41 33 21	61 49 31	101 65 41	121 81 51	141 97 61	161 113 71	
0	0	1	0	0	STX	DC2	"	2	B	R	b	r	22 18 12	42 34 22	62 50 32	102 66 42	122 82 52	142 98 62	162 114 72	
0	0	1	1	0	ETX	DC3 (XOFF)	#	3	C	S	c	s	23 19 13	43 35 23	63 51 33	103 67 43	123 83 53	143 99 63	163 115 73	
0	1	0	0	0	EOT	DC4	\$	4	D	T	d	t	24 20 14	44 36 24	64 52 34	104 68 44	124 84 54	144 100 64	164 116 74	
0	1	0	1	0	ENQ	NAK	%	5	E	U	e	u	25 21 15	45 37 25	65 53 35	105 69 45	125 85 55	145 101 65	165 117 75	
0	1	1	0	0	ACK	SYN	&	6	F	V	f	v	26 22 16	46 38 26	66 54 36	106 70 46	126 86 56	146 102 66	166 118 76	
0	1	1	1	0	BEL	ETB	.	7	G	W	g	w	27 23 17	47 39 27	67 55 37	107 71 47	127 87 57	147 103 67	167 119 77	
1	0	0	0	0	BS	CAN	(	8	H	X	h	x	30 24 18	50 40 28	70 56 38	110 72 48	130 88 58	150 104 68	170 120 78	
1	0	0	1	0	HT	EM	)	9	I	Y	i	y	31 25 19	51 41 29	71 57 39	111 73 49	131 89 59	151 105 69	171 121 79	
1	0	1	0	0	LF	SUB	,	10	J	Z	j	z	32 26 1A	52 42 2A	72 58 3A	112 74 4A	132 90 5A	152 106 6A	172 122 7A	
1	0	1	1	0	VT	ESC	+	11	K	[	k	{	33 27 1B	53 43 2B	73 59 3B	113 75 4B	133 91 5B	153 107 6B	173 123 7B	
1	1	0	0	0	FF	FS	.	12	L	\	l		34 28 1C	54 44 2C	74 60 3C	114 76 4C	134 92 5C	154 108 6C	174 124 7C	
1	1	0	1	0	CR	GS	-	13	M	]	m	}	35 29 1D	55 45 2D	75 61 3D	115 77 4D	135 93 5D	155 109 6D	175 125 7D	
1	1	1	0	0	SO	RS	.	14	N	^	n	~	36 30 1E	56 46 2E	76 62 3E	116 78 4E	136 94 5E	156 110 6E	176 126 7E	
1	1	1	1	0	SI	US	/	15	O	_	o	DEL	37 31 1F	57 47 2F	77 63 3F	117 79 4F	137 95 5F	157 111 6F	177 127 7F	

## Appendix C

---

---

# D

## *Communication and Trademark Information*

### **Communication Notices**

---

Federal Communications Commission (FCC) Statement: This equipment has been tested and found to comply with the limits for a Class A digital device, pursuant to Part 15 of the FCC Rules. These limits are designed to provide reasonable protection against harmful interference when the equipment is operated in a commercial environment. This equipment generates, uses, and can radiate radio frequency energy and, if not installed and used in accordance with the instruction manual, may cause harmful interference to radio communications. Operation of this equipment in a residential area is likely to cause harmful interference, in which case the user will be required to correct the interference at his own expense.

Properly shielded and grounded cables and connectors must be used in order to meet FCC emission limits. Compaq is not responsible for any radio or television interference caused by using other than recommended cables and connectors or by unauthorized changes or modifications to this equipment. Unauthorized changes or modifications could void the user's authority to operate the equipment.

This device complies with Part 15 of the FCC Rules. Operation is subject to the following two conditions: (1) this device may not cause harmful interference, and (2) this device must accept any interference received, including interference that may cause undesired operation.

Canadian Department of Communications Compliance Statement:

This Class A digital apparatus meets all requirements of the Canadian Interference-Causing Equipment Regulations.

Avis de conformité aux normes du ministère des Communications du Canada:

Cet appareil numérique de la classe A respecte toutes les exigences du Règlement sur le matériel brouilleur du Canada.

European Union (EC) Electromagnetic Compatibility Directives: This product is in conformity with the protection requirements of EC Council Directive 89/336/EEC on the approximation of the laws of the Member States relating to electromagnetic compatibility. Compaq cannot accept responsibility for any failure to satisfy the protection requirements resulting from a non-recommended modification of the product, including the fitting of non-Compaq option cards.

Dieses Gerät ist berechtigt in Übereinstimmung mit dem deutschen EMVG vom 9.Nov.92 das EG-Konformitätszeichen zu führen.

Properly shielded and grounded cables and connectors must be used in order to reduce the potential for causing interference to radio and TV communication and to other electrical or electronic equipment.

This product has been tested and found to comply with limits for Class A Information Technology Equipment according to CISPR 22/European Standard EN 55022. The limits for Class A equipment were derived for commercial and industrial environments to provide reasonable protection against interference with licensed communication equipment.

Warning: This is a Class A product. In a domestic environment this product may cause radio interference in which case the user may be required to take adequate measures.

Dieses Gerät erfüllt die Bedingungen der EN 55022 Klasse A. Für diese Klasse von Geräten gilt folgende Bestimmung nach dem EMVG:

---

Geräte dürfen an Orten, für die sie nicht ausreichend entstört sind, nur mit besonderer Genehmigung des Bundesministers für Post und Telekommunikation oder des Bundesamtes für Post und Telekommunikation betrieben werden. Die Genehmigung wird erteilt, wenn keine elektromagnetischen Störungen zu erwarten sind.

(Auszug aus dem EMVG vom 9.Nov.92, Para.3, Abs.4)

Hinweis: Dieses Genehmigungsverfahren ist von der Deutschen Bundespost noch nicht veröffentlicht worden.

**警告使用者：**

這是甲類的資訊產品，在居住的環境中使用時，可能會造成射頻干擾，在這種情況下，使用者會被要求採取某些適當的對策。

## **Trademark Acknowledgments**

---

IBM, AS/400, AIX and Proprinter are registered trademarks, and PC-DOS, Intelligent Printer Data Stream and IPDS are trademarks of International Business Machines Corporation.

Adobe, TranScript, and PostScript are registered trademarks of Adobe Systems Incorporated.

Compaq is a registered trademark of Compaq Computer Corporation.

Centronics is a registered trademark of Genicom Corporation.

CSA is a registered certification mark of the Canadian Standards Association.

Dataproducts is a registered trademark of Dataproducts Corporation.

EIA is a registered service mark of the Electronic Industries Association.

## Appendix D

### Trademark Acknowledgments

---

Epson is a registered trademark of Seiko Epson Corporation.

Ethernet is a trademark of Xerox Corporation.

FTP Software is a registered trademark of FTP Software, Inc.

Hewlett-Packard, PCL, HP, and HP-UX are registered trademarks, and PCL is a trademark of Hewlett-Packard Company.

IEEE is a registered service mark of the Institute of Electrical and Electronic Engineers, Inc.

Novell and NetWare are registered trademarks of Novell, Inc.

Printronix, PGL, LinePrinter Plus, and IGP are registered trademarks, and SureStak and RibbonMinder are trademarks of Printronix, Inc.

QMS is a registered trademark, and Code V is a trademark of Quality Micro Systems, Inc.

Microsoft, MS, Windows and MS-DOS are registered trademarks of Microsoft Corporation.

Sun and Solaris are registered trademarks of Sun Microsystems, Inc.

TUV is a registered certification mark of TUV Rheinland of North America, Inc.

UL is a registered certification mark of Underwriters Laboratories, Inc.

UNIX is a registered trademark of X/Open Company Limited.

ENERGY STAR is a registered trademark of the United States Environmental Protection Agency. As an ENERGY STAR® Partner, Compaq has determined that this product meets the ENERGY STAR® guidelines for energy efficiency.



---

# Index

## Numerics

021 RECEIVE BUFFER OVERRUN  
VERIFY CONFIGURATION message, 201  
1284 Parallel interface, 134  
15V PWR FAIL \* message, 201  
20 CPI Condensed, 89, 92  
23.5V PWR FAIL \* message, 201  
48V PWR FAIL \* message, 201  
8.5V PWR FAIL \* message, 201

## A

A TO D OVERUN \* message, 201  
Absorb after ^PY, 106  
ACCESS NULL PTR \* message, 201  
ACTIVE EMULATION Menu, 73  
Adjustments  
    loading Flash memory, 213  
    software upgrades, 213  
Alt. Set 80-9F, 86  
Alternate Char Set, 89  
Alternate Set 80-9F, 92  
Append Rotated, 106  
ASCII Character Set chart, 219  
Auto LF, 84, 88, 91  
Auto Uppercase, 98  
Autowrap, 96

## B

Barcode

Errors, 109  
Baud Rate, 118  
BTU, 211  
Buffer Clear signal  
    Dataproducts Long Lines, 133  
BUFFER OVERFLOW message, 201  
Buffer Size in K, 116, 119, 120, 121  
Byte mode, 134

## C

Cable length  
    Dataproducts interface  
    Long Lines, 132  
    IEEE 1284 parallel, 136  
    serial, 140  
Cable verify signal  
    Dataproducts Long Lines interface,  
        133  
Canceling Print Job, 60  
CAUTION PPM HAS REMOTE CONTROL  
message, 201  
Chains  
    cabinet model, 23  
Changing Parameter Settings, 62  
Changing Parameters Example, 64  
Character Set, 86, 88, 92  
    U.S. ASCII, 219  
CLEAR key, 44  
CLEAR PAPER JAM message, 201  
Clear To Send (CTS) signal

## Index

---

- RS-232 serial interface, 141
- CLEARING PROGRAM FROM FLASH, 216, 218
- CLOSE PLATEN message, 201
- Code chart
  - U.S. ASCII, 219
- COIL HOT, 202
- Communication
  - IEEE 1284 parallel (bidirectional), 134
- Compatibility Mode
  - IEEE 1284 interface, 134
- Compiling Host Software
  - pre-compiled binaries
  - adding setups, 147
- Component locations, 18
- Compressed CPI, 99
- CONFIG. CONTROL Menu, 71
- Configuration Main Menu, 69
- Configuration Overview, 61
- Configuration Printout, 78
- Configuring the Emulation with the Control Panel, 102
- Configuring the Internal Ethernet Adapter, 172
  - host configuration, 174
  - PSERVER bootup, 174
  - RPRINTER bootup, 174
  - host software, 172
  - internal ethernet adapter, 173
  - netware 4 options, 180
  - PSERVER Setup, 175
  - RPRINTER Setup, 177
  - TCP/IP, 146
- Configuring the Internal Ethernet Adapter for Windows, 183
  - basic setup, 184
  - central host, 183
  - configuring TCP/IP on windows workstations, 186
  - print methods overview, 183
  - print setup possibilities, 183
  - TCP/IP Setup
    - configuring TCP/IP on your windows workstations
    - windows for workgroups, 187
  - configuring TCP/IP for Windows Workstations
  - windows NT, 187
  - Windows 95 NetBIOS Network installation, 186
  - Windows for Workgroups NetBIOS installation, 185
  - Windows NT LPR installation, 184
  - Windows NT NetBIOS Network installation, 185
  - TCP/IP setup, 184
- Connections
  - cord, 27
  - interface, 27
- Control Code 06, 84
- Control Code 08, 84
- Control codes
  - overview description, 14
- Control panel overlays, attaching, 31

## Index

---

Cord connections, 27

CPI/LPI Select, 80

CR Edit, 97

CTL VOLT FAIL \* message, 202

### D

Data Bit 8, 109, 114

Data Carrier Detect (DCD) signal

RS-232 serial interface, 141

Data lines 1 through 8 signal

Dataproducts Long Lines interface,  
133

Data Polarity, 115

Data Protocol, 117

Data Set Ready (DSR) signal

RS-232 serial interface, 141

Data strobe signal

Dataproducts Long Lines interface,  
133

Data Terminal Ready, 118

Dataproducts (Standard & Long Lines)

Submenu, 114

Dataproducts Long Lines interface signals

Buffer Clear, 133

cable verify, 133

data lines 1 through 8, 133

data strobe, 133

demand, 133

online, 133

Paper Instruction (PI), 133

Parity error, 133

ready, 133

test, 133

Dataproducts Long Lines Parallel Interface

Host System Configuration

SYSGEN, 142

Dataproducts parallel interface signals, 133

Default and Custom Configurations, 62

Define CR Code, 84, 87, 91

Define LF Code, 85, 88, 91

Define LF Code (Line Feed), 96

Delete Config, 72

Demand signal

Dataproducts Long Lines interface,  
133

DIAGNOSTICS Menu, 125

DIAGNOSTICS PASSED, 216

Dimensions

printer, 209

Display Language, 112

Displaying Functions, 77

Distance required from host

printer installation, 16

Documentation list, 13

DRVR CIR BAD \* message, 202

### E

Electrical characteristics, 211

EMULATION Menu, 74

Emulations, 14

Emulations, optional, 74

Energy Star compliance, 210

ENTER key, 45

Environmental characteristics, 210

Epson FX-1050 Emulation, 90

ERROR DC PROGRAM NOT VALID, 216

## Index

---

- ERROR DRAM AT ADDRESS  
XXXXXXXX, 216
- ERROR EC PROGRAM NOT VALID, 216
- ERROR EC STOPPED AT STATE XXXX,  
216
- ERROR FLASH NOT DETECTED, 217
- Error Handling, 108
- Error markers, 108
- Error messages See Fault messages, 200
- ERROR NO DRAM DETECTED, 216
- ERROR NVRAM FAILURE, 217
- ERROR PROGRAM NEEDS MORE  
DRAM, 217
- ERROR PROGRAM NEEDS MORE  
FLASH, 217
- ERROR PROGRAM NOT COMPATIBLE,  
217
- ERROR PROGRAM NOT VALID, 217
- ERROR SECURITY PAL NOT  
DETECTED, 217
- ERROR SHORT AT ADDRESS XXXX, 217
- ERROR WRITING TO FLASH, 216, 217
- ERROR WRONG CHECKSUM, 218
- ETHERNET PARAMETERS Menu, 122
- Ethernet Submenu, 121
- EVFU Select, 86
- EXHAUST FAN FLT message, 202
- Extended Execute Copy, 99
- ezsetup  
    installation program  
    setting up, 147
- F**
- Fault Action, 130
- Fault messages, 200
- 021 RECEIVE BUFFER OVERRUN  
        VERIFY CONFIGURATION,  
        201
- 15V PWR FAIL \*, 201
- 23.5V PWR FAIL \*, 201
- 48V PWR FAIL \*, 201
- 8.5V PWR FAIL \*, 201
- A TO D OVERUN \*, 201
- ACCESS NULL PTR \*, 201
- BUFFER OVERFLOW, 201
- CAUTION PPM HAS REMOTE  
        CONTROL, 201
- CLEAR PAPER JAM, 201
- CLOSE PLATEN, 201
- COIL HOT, 202
- CTL VOLT FAIL \*, 202
- DRVR CIR BAD \*, 202
- EXHAUST FAN FLT, 202
- FIRMWARE ERROR, 202
- FRAMING ERROR, 202
- HAM. COIL OPEN \*, 202
- HAMMER COIL BAD, ###, 202
- HB NOT INSTALLD \*, 203
- ILL EXT BUS ACC \*, 203
- ILL INST ACCSS \*, 203
- ILLGL OPR ACCSS \*, 203
- INTAKE FAN FAULT, 203
- LO DRV. SHORT \*, 203
- LOAD PAPER, 203

## Index

---

ONLINE 8344 FAILED, 203  
PAP BAD TABLE \*, 203  
PAP BSY TOO LNG \*, 203  
PAP FIFO OVERFL \*, 203  
PAP FIFO UNDRFL \*, 203  
PAP ILLGL ST \*, 204  
PAP INCMPL ENER \*, 204  
PAP INVLD CMD \*, 204  
PAP INVLD PARM \*, 204  
PAP NOT SCHED \*, 204  
PAP NT AT SPEED \*, 204  
PAP UNEXP INT \*, 204  
PARITY ERROR, 204  
PLAT INV CMD \*, 204  
PLAT INV PARM \*, 204  
PLAT INV STATE \*, 204  
POWER SAVER MODE, 205  
POWERSUPPLY HOT \*, 204  
PRINTER HOT \*, 205  
PROTECTED INSTR \*, 204  
PWRSUPP VOLT \*, 205  
RIB INVLD CMD \*, 205  
RIB INVLD STAT \*, 205  
RIBBON DRIVE, 205  
RIBBON INK OUT, CHANGE  
RIBBON, 205  
SECURITY VIOLATION, 205  
SHUTL INV CMD \*, 205  
SHUTL INV PARM \*, 205  
SHUTTLE JAM, 205  
SOFTWARE ERROR \*, 206  
STACK OVERFLOW \*, 206  
FF key, 43  
FF Valid at TOF, 88  
FIRMWARE ERROR message, 202  
Flash memory, loading, 213  
Flash messages  
CLEARING PROGRAM FROM  
FLASH, 216, 218  
DIAGNOSTICS PASSED, 216  
ERROR DC PROGRAM NOT VALID,  
216  
ERROR DRAM AT ADDRESS  
XXXXXXXX, 216  
ERROR EC PROGRAM NOT VALID,  
216  
ERROR EC STOPPED AT STATE  
XXXX, 216  
ERROR FLASH NOT DETECTED,  
217  
ERROR NO DRAM DETECTED, 216  
ERROR NVRAM FAILURE, 217  
ERROR PROGRAM NEEDS MORE  
DRAM, 217  
ERROR PROGRAM NEEDS MORE  
FLASH, 217  
ERROR PROGRAM NOT  
COMPATIBLE, 217  
ERROR PROGRAM NOT VALID, 217  
ERROR SECURITY PAL NOT  
DETECTED, 217  
ERROR SHORT AT ADDRESS XXXX,  
217  
ERROR WRITING TO FLASH, 216,

## Index

---

- 217
- ERROR WRONG CHECKSUM, 218
- LOADING PROGRAM FROM PORT  
XX%, 218
- RESETTING . . . / PLEASE WAIT, 218
- RESTORING BOOT CODE, 218
- SECURITY CODE VIOLATION, 218
- SENDING PROGRAM TO EC  
PROCESSOR, 218
- TABLE MISMATCH DOWNLOAD  
AGAIN, 218
- Font Attributes, 80
- Format Conventions, 41
- Forms Length, 82
- Forms Width, 82
- FRAMING ERROR message, 202
- G**
- Graphics Density, 77
- Graphics Enhancements, 13
- Graphics Options, 105
- H**
- HAM. COIL OPEN \* message, 202
- HAMMER COIL BAD, ### Message, 202
- Hardware installation
  - adjusting paper supports, 22
  - attach output basket to pedestal  
model, 26
  - paper chains release, 23
  - removing tags from cabinet model, 24
  - removing tags from pedestal model, 25
- HB NOT INSTALLED \* message, 203
- Hex code printout, 198
- Hex Dump Mode, 112
- HOST INTERFACE Menu, 113
- Host System Configuration, 142
- Humidity requirements, 16
- I**
- IEEE 1284
  - interface, 134
  - operating modes, 134
  - signals, 137
- IEEE 1284 Parallel (Bidirectional)  
Submenu, 120
- Ignore / DB8 Setup, 109
- Ignore Character, 99
- Ignore Dots, 106
- Ignore Spaces, 107
- IGP, 101
- IGP 110 Compatible, 108
- IGP/PGL
  - Emulation, 93
  - Submenu, 95
- IGP/VGL
  - Emulation, 101
- IGP/VGL Emulation Submenu, 103
- IGP100 Compatibility, IGP/PGL, 100
- ILL EXT BUS ACC \* message, 203
- ILL INST ACCSS \* message, 203
- ILLGL OPR ACCSS \* message, 203
- Installation
  - Cord connections, 27
  - Interface connections, 27
  - power requirements, 15

## Index

---

- ribbon, 32
  - site requirements, 16
- INTAKE FAN FAULT message, 203
- Interface specifications, 212
- Interface Type, 117
- Interfaces, 131
  - IEEE 1284, 134
  - Optional Interfaces, 30
  - Standard interfaces, 30

### L

- L.P.I. ADJ. key, 45
- Labels, specifications, 208
- Latch Data On, 115
- LF key, 43
- Line Terminator, 77
- LinePrinter Plus Emulation Submenu, 79
- LO DRV. SHORT \* message, 203
- Load Config, 71
- LOAD PAPER message, 203
- Loading emulations, 74
- Loading paper, 34, 47
- LOADING PROGRAM FROM PORT XX%, 218
- LP PLUS emulations, 74
- LPI, 105
- LPI Adjust, 78

### M

- MAINT / MISC Menu, 112
- Maintenance, 14
- Memory, flash
  - loading software, 213

- Midline ^PY (includes ^PN), 107

### N

- Navigating the Menus, 63
- NetWare 4 Options See Configuring the Internal Ethernet Adapter, 180
- New Ribbon, 129
- Nibble mode, 134
- npconfig
  - installation program
  - setting up, 147

### O

- Offpage Errors, 109
- ON LINE key, 43
- ONLINE 8344 FAILED message, 203
- Online signal
  - Dataproducts Long Lines interface, 133
- Operating Modes
  - FAULT, 41
  - OFFLINE, 41
  - ONLINE, 41
- Optimized Ratio, 100
- Optional emulations, 74
- Overlays, control panel, 31
- Overstrike, 85

### P

- Page Format, 82
- PAGE L. ADJ. key, 45
- Page Length Adjust/Inches, 78
- Page Length Adjust/Lines, 78

## Index

---

- Page Length Representation, 77
- PAP BAD TABLE \* message, 203
- PAP BSY TOO LNG \* message, 203
- PAP FIFO OVERFL \* message, 203
- PAP FIFO UNDRFL \* message, 203
- PAP ILLGL ST \* message, 204
- PAP INCMPL ENER \* message, 204
- PAP INVLD CMD \* message, 204
- PAP INVLD PARM \* message, 204
- PAP NOT SCHED \* message, 204
- PAP NT AT SPEED \* message, 204
- PAP UNEXP INT \* message, 204
- Paper
  - jams, 201
  - loading, 34
  - specifications, 208
- Paper chains
  - cabinet model, 23
- Paper Instruction (PI) signal
  - Dataproducts Long Lines interface, 133
- Paper Out Dots, 127
- Parity, 118
- PARITY ERROR message, 204
- Perforation Skip, 82
- Perforation, skipping, setting with control panel, 77
- PI Control, 110
- PI Ignored, 114
- PI Slew Range, 97
- PLAT INV CMD \* message, 204
- PLAT INV PARM \* message, 204
- PLAT INV STATE \* message, 204
- Plot rates, 212
- PMD (Paper Motion Detection) Fault, 123
- Power
  - consumption, 211
  - requirements, 15, 211
- Power On IGP/PGL, 98
- Power Paper Stacker
  - Unloading Paper, 55
- POWER SAVER MODE message, 205
- Power Saver Time, 124
- POWER SUPPLY HOT \* message, 204
- Powering on the Printer
  - Printer selftest, 41
- Power-Up Config, 72
- Power-Up State, 112
- PREV or NEXT key, 46
- Primary Character Set, 76
- Prime Signal, 115, 120
- Print Char Set, 80
- Print Config, 72
- Print Job
  - canceling, 60
- Print Statistics, 127
- Printer
  - dimensions, 209
  - features, 11
  - installation, distance required from host, 16
  - interfaces, 131
  - maintenance, 14
  - models, 11



## Index

---

- specifications, 207
  - temperature requirements, 16
  - PRINTER CONTROL Menu, 123
  - Printer Dimensions
    - Setting Up the Printer, 17
  - PRINTER HOT \* message, 205
  - Printer Protocol, 80
  - Printer Select, 91
  - Printer Tests, 125
  - printing conventions
    - manual, 12
  - Printouts
    - hex code, 198
  - Proprinter XL Emulation, 87
  - Protect Configs, 72
  - PROTECTED INSTR \* message, 204
  - Protocol, 14
  - P-Series Emulation, 83
  - PSERVER Bootup See Configuring the Internal Ethernet Adapter, 174
  - PSERVER Setup See Configuring the Internal Ethernet Adapter, 175
  - PTX Linefeed, 78
  - PWRSUPP VOLT \* message, 205
- R**
- Ready signal
    - Dataproducts Long Lines interface, 133
  - Received Data (RD) signal
    - RS-232 serial interface, 141
  - Received data (RD) signal
    - RS-422 serial interface, 141
  - Reloading Paper, 47
  - Replacing the Ribbon, 57
  - Request to Send, 119
  - Request To Send (RTS) signal
    - RS-232 serial interface, 141
  - Requirements
    - printer, power, 15
  - RESETTING . . . / PLEASE WAIT, 218
  - Resistors
    - configuration, 138
    - installation, 139
    - removal, 139
  - Response Polarity, 115
  - RESTORING BOOT CODE, 218
  - RIB INVLD CMD \* message, 205
  - RIB INVLD STATE \* message, 205
  - Ribbon
    - installing, 32
    - specifications, 207
  - Ribbon Action, 129
  - Ribbon Adjust, 130
  - RIBBON DRIVE message, 205
  - RIBBON INK OUT, CHANGE RIBBON, 205
  - Ribbon Size, 130
  - RibbonMinder Fault, 130
  - RIBBONMINDER Menu, 128
  - Rot. Char Size, 107
  - RPRINTER Bootup See Configuring the Internal Ethernet Adapter, 174
  - RPRINTER Setup See Configuring the Internal Ethernet Adapter, 177

## Index

---

RS-232 serial interface  
Clear To Send (CTS), 141  
Data Carrier Detect (DCD), 141  
Data Set Ready (DSR), 141  
Received Data (RD), 141  
Request To Send (RTS), 141  
Transmitted Data (TD), 141

RS-422 serial interface  
received data (RD), 141  
transmitted data (TD), 141

### S

Save Config, 72  
Saving Your New Configuration, 66  
Secondary Character Set, 76  
SECURITY CODE VIOLATION, 218  
SECURITY VIOLATION message, 205  
Select Font, 97  
Select LPI, 98  
Select SFCC, 85, 96  
SENDING PROGRAM TO EC  
PROCESSOR, 218  
Serial Configuration  
Host System Configuration, 143  
Serial Submenu, 116  
SET TOF key, 45  
Setting TOF, 38  
SFCC & Pwrup, 104  
SFCC d Command, 86  
SHIFT key, 45  
Shipping restraints  
removal, 19  
SHUTL INV CMD \* message, 205

SHUTL INV PARM \* message, 205  
SHUTTLE JAM message, 205  
Signals  
Dataproducts parallel interface, 133  
IEEE 1284 interface, 137  
Site requirements, printer, 16  
Skip Command Prefix, 98  
Slashes in Zeros, 105  
Slow Paper Slew, 124  
Software

loading into Flash memory, 213  
SOFTWARE ERROR \* message, 206

Specifications  
dimensions, printer, 209  
electrical, 211  
environmental, 210  
interfaces, 212  
paper, 208  
printing rates, 212  
ribbon, 207

Speed of printing, 212  
STACK OVERFLOW \* message, 206  
Stop Bits, 118  
Symbol Set Printout, 78  
System Memory, 127

### T

TABLE MISMATCH DOWNLOAD AGAIN,  
218  
TCP/IP  
Configuration, 146  
TCP/IP Host Software  
setup programs, 146

## Index

---

TCP/IP LAN Configuration

Host System Configuration, 142

Spoolcom, 142

Terminating resistor configuration, 138

Test Width, 127

TOF Action, 115, 120

Top-of-form, 38

Transmitted Data (TD) signal

RS-232 serial interface, 141

RS-422 serial interface, 141

Truncate Alpha, 106

### U

U.S. ASCII Character Set, 219

Unidirectional, 123

unloading paper, 55

Unpacking a new printer, 19

UP or DOWN key, 46

UPC Descenders, 99, 107

Upgrading software, 213

Using the Control Panels, 42

### V

VIEW key, 44

### W

Wattage, printer, 211

Word Length, 118



**Index**





# 5525B/31/32 Line Matrix Printer

**Compaq Computer Corporation**

**P/N 422721-001**

170115-001A