

Installation Manual

Orion EMS

Copyrights

The information in this document is subject to change at the sole discretion of VingCard Elsafe without notice.

Any use, operation or repair in contravention of this document is at your own risk. VingCard Elsafe does not assume any responsibility for incidental or consequential damages arising from the use of this manual.

All information and drawings in this document are the property of VingCard Elsafe as. Unauthorized use and reproduction is prohibited.

VingCard is a registered trademark of VingCard Elsafe AS.

Table of contents

1. GENERAL	4
2. SOFTWARE INSTALLATION	5
2.2 Installing an Orion EMS client	5
2.2.1 Starting an Orion EMS client.....	5
3. COMPONENT INFORMATION.....	6
3.1 Thermostat controller	6
3.1.1 Thermostat controller dimensions	6
3.2 Thermostat.....	7
3.2.1 Thermostat buttons	7
3.2.2 Thermostat display	8
3.2.3 Thermostat dimensions.....	9
3.3 Parameters / specifications	10
3.4 Motion sensor	12
3.4.1 Motion sensor dimensions	13
3.4.2 Motion sensor specifications.....	13
4. DEVICE INSTALLATION AND COMMISSIONING	16
4.1 Inputs / outputs	16
4.1.1 Configuration with thermostat controller	17
4.1.2 Configuration without thermostat controller.....	18
4.2 Installing a thermostat controller	19
4.2.1 Mounting a thermostat controller.....	19
4.3 Installing a thermostat	20
4.3.1 Mounting a thermostat.....	20
4.3.1.1 Thermostat placement.....	21
4.3.1.2 Thermostat battery exchange.....	21
4.3.2 Wiring a thermostat.....	21
4.3.2.1 Recommended wire specification.....	21
4.3.2.2 Connecting a thermostat.....	21
4.3.2.3 Line to low voltage conversion	22
4.3.2.4 Connecting a wired door switch	22
4.4 Installing a motion sensor.....	23
4.4.1 Motion sensor placement	24
4.5 Commissioning the system.....	25
4.5.1 Commissioning when thermostat controller is used.....	25
4.5.1.1 Joining the thermostat controller to the network	25
4.5.1.2 Joining the in-room devices to the thermostat controller	26
4.5.2 Commissioning when thermostat controller is not used.....	27
4.5.2.1 Joining the thermostat to the network.....	27
4.5.2.2 Joining the in-room devices to the thermostat.....	28
4.6 Testing the in-room devices	30
APPENDIX A: ORION SERVICE CONNECTIONS	31
APPENDIX B: FIRMWARE UPGRADE	35
APPENDIX C: CONFIGURATION IN OFFLINE SCENARIOS.....	39
REVISION HISTORY	48

1. General

This manual

- describes how to install the Orion EMS (*Energy Management System*) option and if applicable an Orion EMS client; chapter 2
 - for the Orion EMS features to be shown in the VISIONLINE software, it is necessary to install the *Orion EMS option*; follow the steps in section 2.1
 - if the Orion EMS features should also be available in a separate client where the operators do not see the “ordinary” VISIONLINE items such as doors, follow the steps in section 2.2; this requires that the Orion EMS option has been installed in the VISIONLINE software
- gives information about the Orion EMS devices and parameters; chapter 3
- describes how to install and commission the Orion EMS devices; chapter 4

Note: For daily operations when the system is in use, see *Daily use manual Orion EMS*. In that document, more information about Orion Service and SysMon (*System Monitor*) features is also found.

The items used together with Orion EMS are:

- digital thermostat

Note: Depending on installation conditions, also a thermostat controller is used or not. If used, the thermostat controller is the master of the system and the thermostat is only a guest interface device which transmits information to the thermostat controller for processing and decision making.
- motion sensor
- door monitoring device; lock, switch
- gateway (the same as is used for online doors; requires the *Online* option which is also installed according to 2.1)

Note: The gateway is not used in offline scenarios; see *Appendix C* for details.

Note: For each room number, it is possible to have either

- one wired thermostat
- up to five motion sensors
- up to five door switches

OR

- one thermostat controller
- up to five battery thermostats
- up to five motion sensors
- up to five door switches

Note: The best conditions for Orion EMS are obtained if also the locks are online and commissioned to the same ZigBee network as the thermostat and the motion sensor.

Note: In the rest of this document, the term ‘thermostat’ includes *thermostat* as well as *thermostat controller*, unless something else is stated.

2. Software installation

2.1 Installing an option

If the *Orion EMS option* (and *Online option*) has been ordered together with the VISIONLINE software, it is included in the license code and will be set in the software when the license code is entered.

If the option(s) should be added to the system at a later occasion, when the license code has already been entered and system ID is therefore set, an option code is used instead. Several software options can be included in one option code. An operator with the authority to handle option codes must be logged on. Normally, options are set by the system manager or the distributor.

When ordering the option, the system code must be communicated to the ordering department:

1. Double click on **System settings** under the **Reports** tab in the navigation window of VISIONLINE. **System settings** is available even if you are not logged on.
2. Communicate your system code to the order department; see order acknowledgement for phone number and e-mail address. The system code can also be entered in the *Ordering web page* when making the order.

To install an option:

1. Go to **Tools/Option code** in VISIONLINE.
2. Enter the option code and click **Apply**.

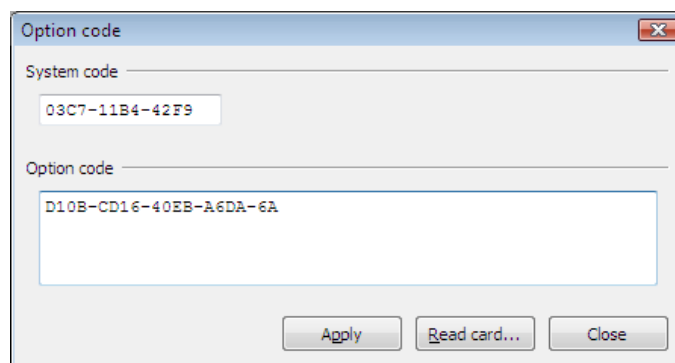

2.2 Installing an Orion EMS client

If there should be a separate Orion EMS client (see chapter 1 for more information), this is installed according to the ReadMe file for the applicable operating system. The ReadMe files are found on the Orion EMS software CD.

2.2.1 Starting an Orion EMS client

1. Click the **Start** button and go to **Programs/Orion EMS/Orion EMS**.
2. When requested, log on with the same user ID and password as for VISIONLINE.

3. Component information

As mentioned in chapter 1 *General*, two different thermostat configurations are available:

- battery operated thermostat that communicates via ZigBee to a wired thermostat controller
- wired thermostat and no thermostat controller

3.1 Thermostat controller

If the configuration with thermostat controller is used, the thermostat controller is the master of the in-room system. This item has a built-in router via which it communicates with the VISIONLINE software (or Orion EMS software, if applicable) and the devices within the room. It is also possible to have an offline scenario where there is no connection to the server, and where each room can be seen as a PAN (*personal area network*) which is controlled by its thermostat controller. In this case, the thermostat controller has a coordinator firmware instead of a router firmware.

Note: The thermostat controller may not be sealed into a metal box.

When the different room devices are commissioned (see section 4.5.1.2 for details), they are joined to the router of the thermostat controller and registered in the thermostat controller.

The thermostat controller stores all parameters needed for the energy management, with a few exceptions which are stored in the thermostat; see section 3.3 for details. These are transferred either from a service device, or online from the VISIONLINE/Orion EMS software.

The thermostat controller receives entry and exit information from the door lock or switch as well as information from the motion sensor. This information is used to determine the occupancy status of the room and implement energy savings strategy based on this information.

3.1.1 Thermostat controller dimensions

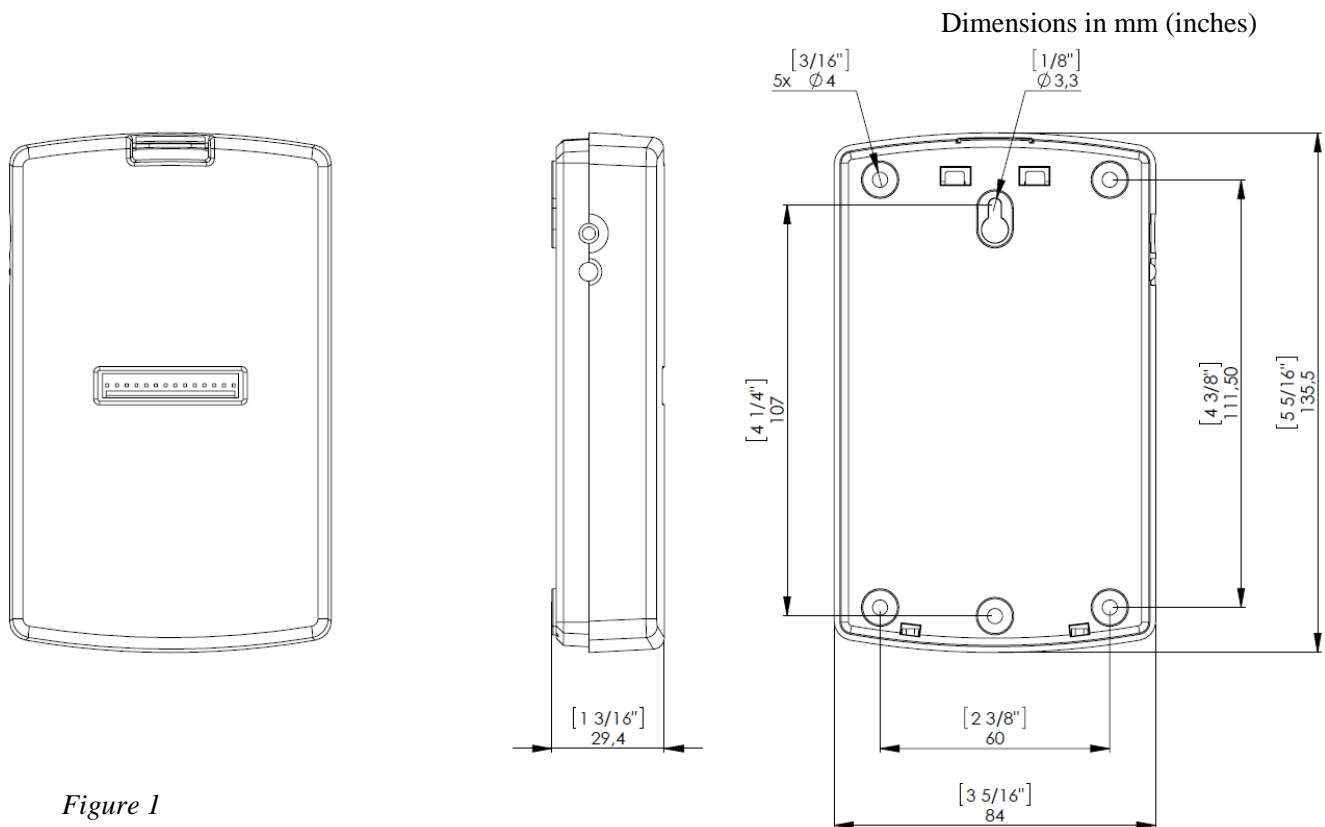

Figure 1

3.2 Thermostat

The guest operates the thermostat, which depending on configuration communicates either

- with the thermostat controller

OR

- directly with the VISIONLINE software/Orion EMS software and the devices within the room.

The thermostat buttons and thermostat display are the same in both cases. In the case of battery operated thermostat, 3AA batteries (4.5 VDC) in a battery package are used.

3.2.1 Thermostat buttons

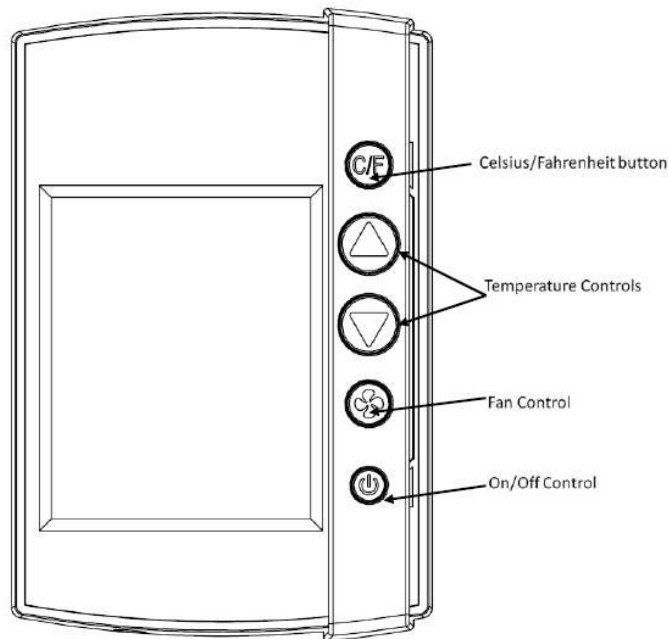

Figure 2

The hotel guest controls the thermostat using the five buttons shown on the right side of the unit in Figure 2.

- **C/F:** Controls the temperature display. Pressing this button will toggle the temperature display between Celsius and Fahrenheit.
- **Up and Down Arrows:** The up and down arrows are used to set the desired temperature. The thermostat will automatically choose between heat and cool so there is no need for the guest to select the function.
Note: Some systems are unable to switch between the heating and cooling functions. This does not change the way the guest uses the system, but the thermostat is programmed accordingly and will not call for a function that is not available.
- **Fan Control Button:** The Fan control button allows the user to select from up to three fan speeds or choose 'Automatic' to let the thermostat determine the appropriate fan setting.
Note: The ability to control fan speeds depends on the capability of the air handler as some systems do not have three fan speeds.
- **On/Off Button:** The On/Off button toggles the thermostat power on or off.
Note: Even when the unit is turned off, the energy management logic will take over when the room is unoccupied to manage the temperature accordingly.

3.2.2 Thermostat display

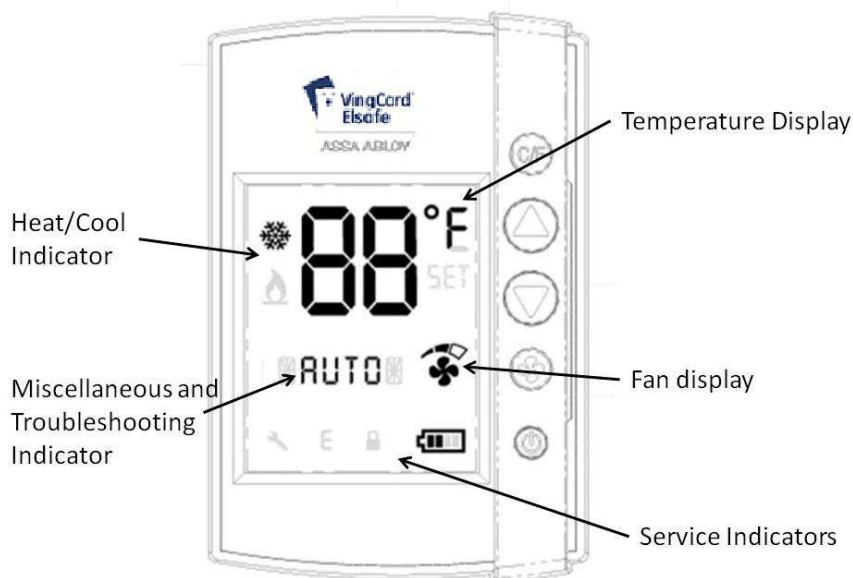

Figure 3

The thermostat displays settings and operation details to the guest, such as room temperature and heat/cool indications.

Display details:

- **Temperature Display:** The temperature display area shows the actual room temperature or the set temperature as well as the indication of Fahrenheit or Celsius. When the displayed temperature is the guest setting, not the actual room temperature, the SET indicator is also displayed.
Note: Whenever a guest is changing the setting, the SET temperature will display.
- **Heat/Cool Indicator:** The thermostat displays universal icons for heating and cooling. The snow star is the symbol to indicate the unit is in cooling mode and the flame is the symbol to indicate heating mode.
- **Fan Display:** The fan display shows the fan speed of the unit. As the fan speed increases, additional segments or the indicator are displayed. When in AUTO fan mode, the word AUTO will appear in the middle of the display (at the Miscellaneous Indicator, see below).
- **Miscellaneous Indicator:** The indicator in the middle of the display is a multi-purpose indicator. It e.g. displays the word AUTO when the automatic fan mode is enabled.
- **Service indicators:**
 - **Wrench Icon:** The wrench icon is displayed when maintenance is required on any of the EMS devices in the room or the HVAC unit. This icon is only displayed to hotel staff. To get the details of the maintenance needed, connect the service terminal to the thermostat.
 - **Error (E) Indicator:** The error indicator is primarily used for the battery operated thermostat and will be displayed when communication between the thermostat and the thermostat controller is lost. When displayed, the thermostat will turn OFF. This indicator is displayed to guests as well as staff, as maintenance is required in order for the system to operate.
 - **Battery Icon:** The battery icon is displayed to hotel staff when the batteries are low (on battery powered units) and in need of replacement.
Note: This is a low indicator only, not a segmented icon that displays the battery level. As soon as this indicator is displayed, the batteries need to be replaced.

Note: If the lock is not used to monitor the door status, the service indicators will only be displayed when the service device is used - with the exception of the error (E) indicator.

3.2.3 Thermostat dimensions

Figure 4 shows the dimensions of the thermostat. The design allows the unit to be mounted onto a US or European single gang box.

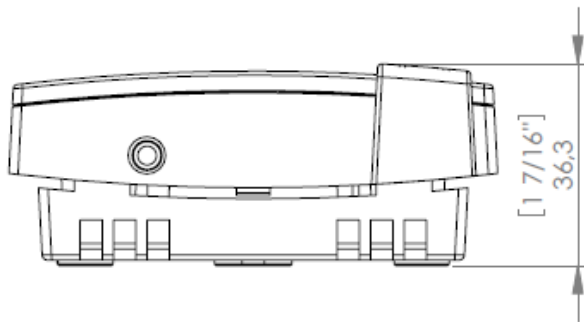

Dimensions in mm (inches)

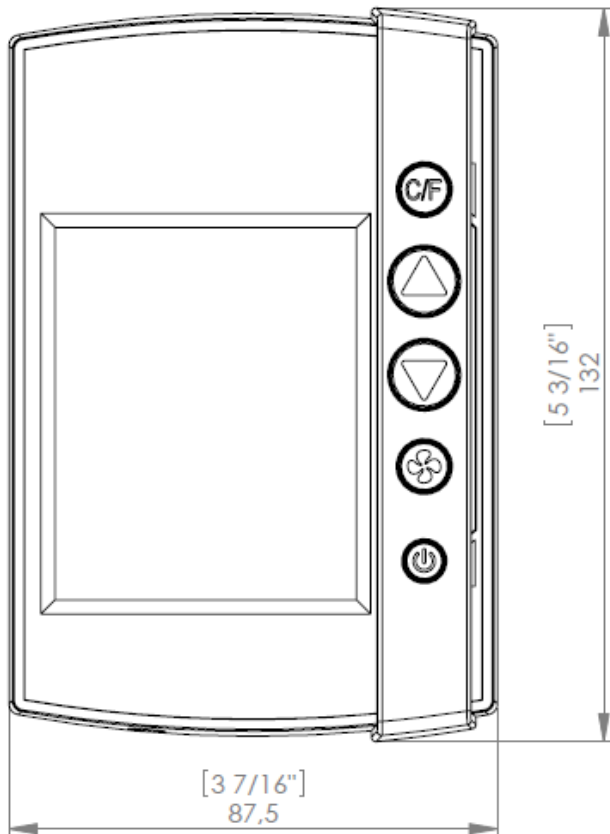

Figure 4

3.3 Parameters / specifications

Temperature display range	2-digit display – no limit
Guest control range*	65 – 90 °F / 18 – 32 °C ; configurable through service device
HVAC control types	Standard H/C; heat pump
Input voltage	12-24V AC 15-24 V DC
Output logic	Input voltage level
Outputs	W/W2 – Heating Y/W2 – Cooling / compressor G1 – Fan 1 G2 – Fan 2 G3 – Fan 3 RV – Reversing valve
Inputs	Door switch – 1 exterior / 1 interior Motion sensor/card switch I/O Service connector (programming)
Temperature sensor*	Integrated in thermostat Option: remote temperature sensor that connects directly to the thermostat controller
RF signals	ZigBee 2006 Lock to thermostat: <ul style="list-style-type: none"> • Door open – staff card • Door open – guest card (includes check-out date/time, suite rooms and first time use) • Door open from inside • Door closed • Deadbolt thrown / released Thermostat to lock: <ul style="list-style-type: none"> • Room occupied – to enable lock to enter AutoDND mode Motion sensor to thermostat: <ul style="list-style-type: none"> • Motion detected • Battery status Thermostat to motion sensor: <ul style="list-style-type: none"> • Turn off when the room is occupied and the door is closed • Turn on when the door is opened again

Thermostat deadband	Configurable 1 – 3 °F; default is 2 °F
Heat cool switching deadband	Configurable 2 – 4 °F; default is 3 °F
Heat / cool switching	Configurable to allow or disallow auto changeover of heat/cool.
Freeze guard	39 °F / 4 °C
Refresh cycle	Optional
Humidity*	Optional
Temperature display	Configurable: Guest setting or room temperature; default is room temperature
Intelligent switch	Configurable: Disabled/use RV output/use G2 output; default is disabled
Room not occupied timer	Configurable 4 – 30 minutes; default is 8 minutes
Room not sold timer	Configurable 12 – 24 hours; default is 16 hours
Compressor delay (dwell-off time)	5 minutes. The dwell-off time prevents short-cycling of the compressor; this parameter cannot be changed

Table 1

Note: For information about where in the software to change the parameters, see the tables for basic and advanced parameters respectively in *Daily use manual Orion EMS*.

*) These parameters are stored in the thermostat even if the thermostat controller is used

3.4 Motion sensor

The motion sensor is used to detect motion in the room and send this information via the ZigBee endnode to the thermostat. The device is designed to be ceiling or wall mounted and is powered by 3AA batteries. No physical connections are required; thus making the installation simple.



Figure 5

3.4.1 Motion sensor dimensions

Dimensions in mm (inches)

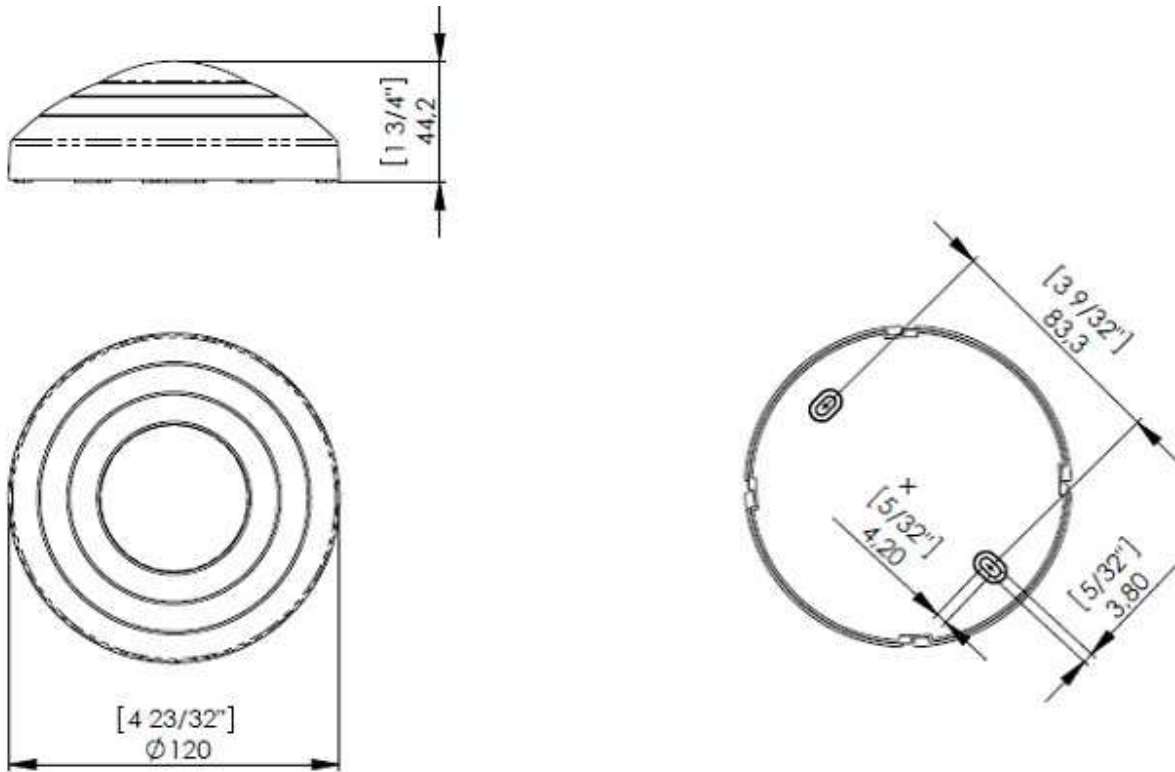

Figure 6

3.4.2 Motion sensor specifications

Input power	3 AA batteries (4.5 VDC)
Mounting	<ul style="list-style-type: none"> • Ceiling or wall surface mounting • Keyhole type for easy installation and battery replacement access
Range	360 degree / 8 meters horizontal / 3 meters vertical
Messages transmitted	<ul style="list-style-type: none"> • Motion detected • Battery status
Diagnostics	Integrated LED only enabled for diagnostics

Table 2

3.5 RF Door switch

If VingCard online locks are not applicable at the installation, an RF door switch can instead be used for monitoring the position of the door. The door switch is powered by 2 AA batteries and the kit also includes a magnet (see Figure 8) and two screws. The door switch can be mounted as it is or on a wall-mounted casing (see Figure 9) which is purchased separately.

Note: For best operation, the magnet should be installed maximum 10 mm (25/64") from the reed switch which is located as in Figure 7.

Note: It is also possible to use a wired door switch without radio; see section 4.3.2.4 for details.

3.5.1 RF door switch dimensions

Dimensions in mm (inches)

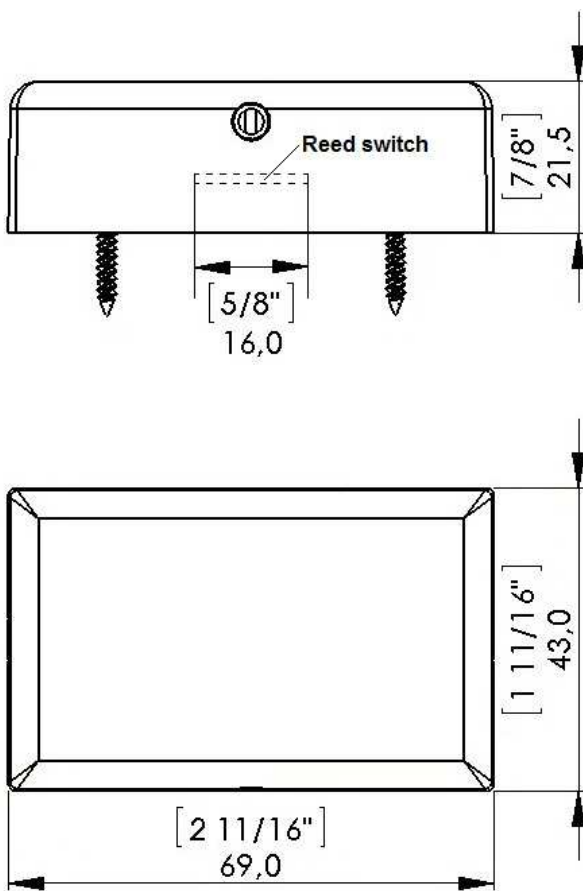

Figure 7

3.5.2 RF door switch magnet dimensions

Note: The magnet must be mounted maximum 10 mm (25/64") from the door switch.

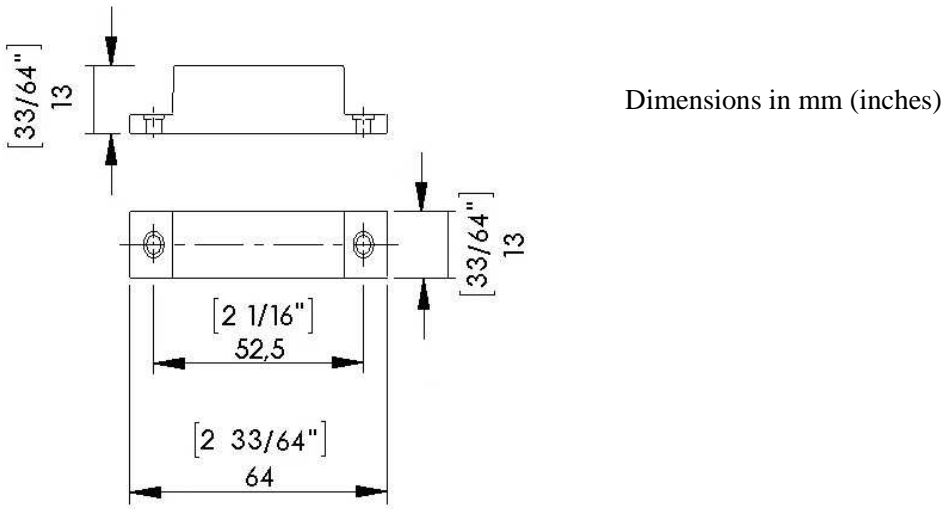

Figure 8

3.5.3 Wall-mounted casing

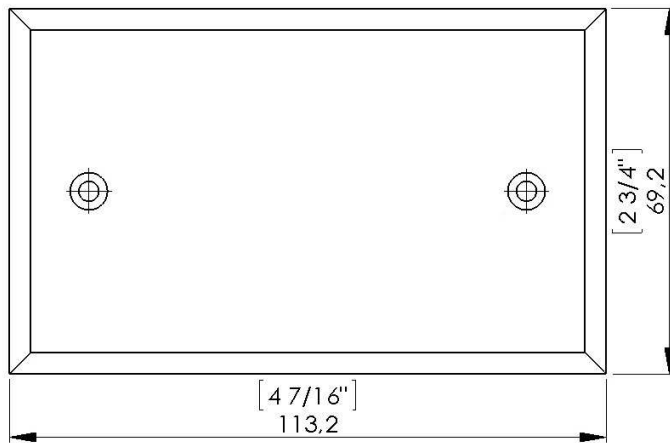

Figure 9

4. Device installation and commissioning

The Orion EMS thermostat is a low voltage (12-24V AC / 15-24V DC) device and the air handler to which it is installed must have a low voltage interface. If no low voltage interface exists, one supplied by the distributor or another qualified installer must be installed. The thermostat may be connected on air handlers with either *standard (on/off)* control or *heat pump* control.

Important: Do not connect the Orion EMS thermostat directly to high voltage as this will destroy the thermostat.

4.1 Inputs / outputs

Table 3 shows the inputs and outputs for the Orion EMS thermostat which are connected via the wiring harness supplied with the thermostat.

Pin	Input / Output	Wire Color
1	W/W2: Heating (output)	White
2	Y/W2: Cooling/Compressor (output)	Yellow
3	G1: Fan 1/low (output)	Green
4	G2: Fan 2/medium (output)	Orange
5	G3:Fan 3/high (output)	Dark blue
6	RV: Reversing valve (output)	Violet
7	Extra output: not used	Brown
8	DS_I: Interior door switch (input)	Gray
9	DS_E: Exterior door switch (input)	Orange/blue
10	EX1: Extra input 1 (motion sensor/ card switch I/O)	Pink
11	GND: Power – Common/Ground	Black
12	V+ (load max 50mA DC)	White/black
13	C: Power input -	Light blue
14	R: Power input +	Red

Table 3

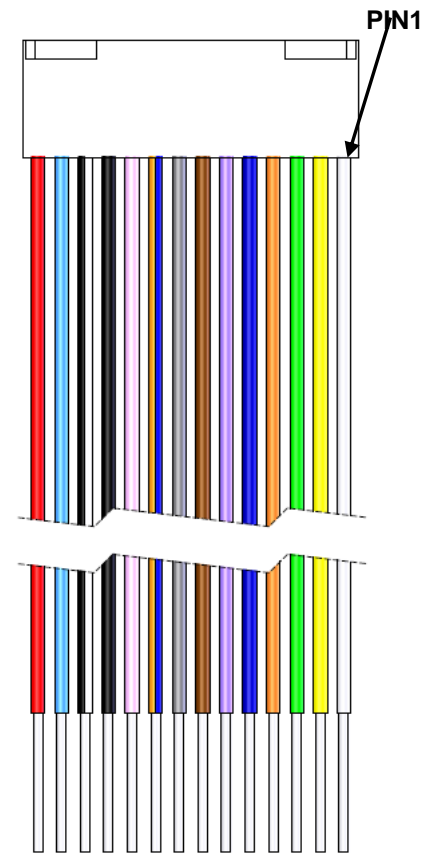

Figure 10: Wire colors of wiring harness

Note: Connect input voltage 12-24V AC or 15-24V DC to pins 13 and 14.

Note: If a thermostat controller is used, the wiring harness is connected at the front of the thermostat controller as shown in Figure 11.

Note: If no thermostat controller is used, the wiring harness is connected at the back of the thermostat as shown in Figure 12.

4.1.1 Configuration with thermostat controller

If the thermostat controller is used, the wiring harness is connected on the thermostat controller front.

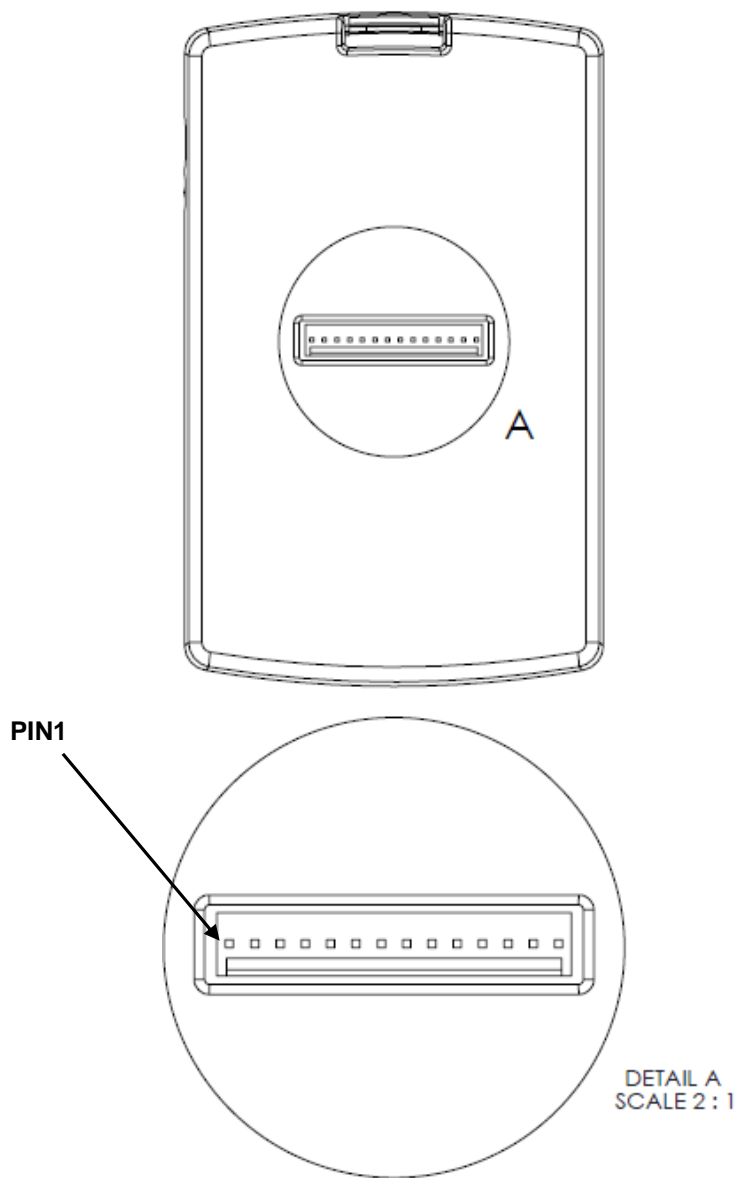

Figure 11

4.1.2 Configuration without thermostat controller

If no thermostat controller is used, the wiring harness is connected on the back of the thermostat.

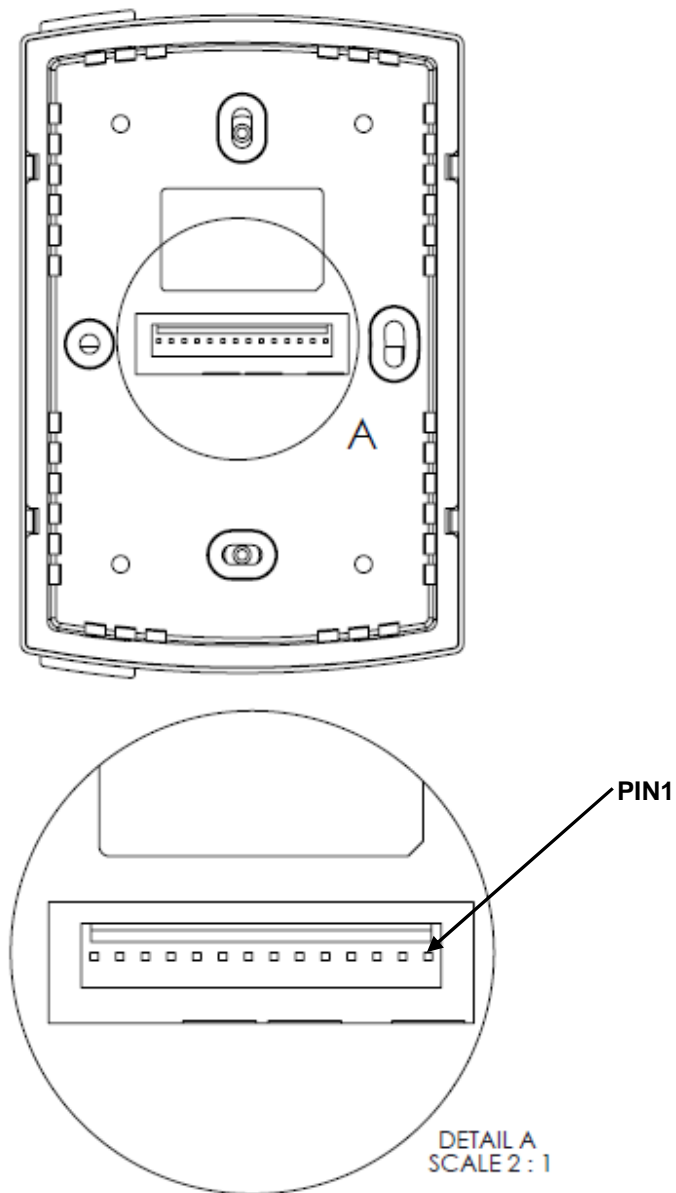

Figure 12

4.2 Installing a thermostat controller

Note: The thermostat controller may not be sealed into a metal box.

4.2.1 Mounting a thermostat controller

The thermostat controller is designed to be installed on a standard US or European single gang switch box.

Figure 10 shows the five screw holes on the back of the thermostat controller.

Note: The thermostat controller may also be installed inside an air handler as long as it is not encased in metal.



Figure 13

1. The mounting bracket is attached using five screws and the thermostat controller can then be snapped into place on the mounting bracket as shown in Figure 14.
2. Once the wiring harness is connected, it is best to insert the thermostat controller on the bottom snaps first; then press down on the top of the mounting bracket as the top is snapped into place.

To remove a thermostat controller:

1. Press down on the top of the mounting bracket to release the snaps and pull the top of the thermostat controller away from the wall; then lift up to completely remove from the bracket.

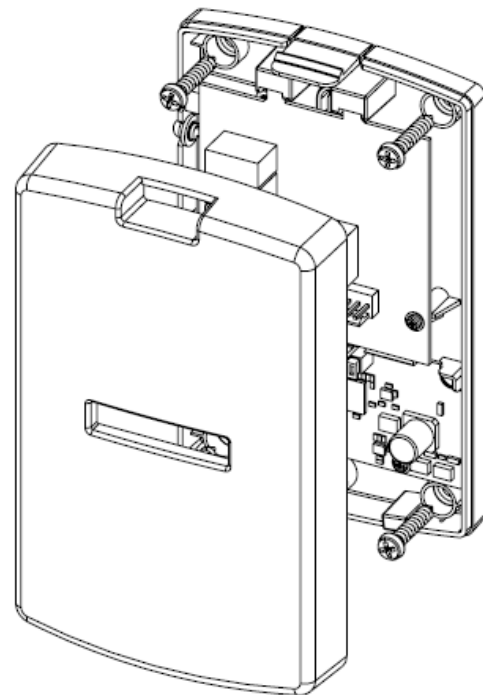

Figure 14

4.3 Installing a thermostat

The thermostat is only to be installed by qualified installers. All local codes must be followed when installing this thermostat. The thermostat will control a variety of HVAC systems and the installation will vary based on the type of system to which it is installed.

4.3.1 Mounting a thermostat

The thermostat is designed to be installed on a standard US or European single gang switch box.

1. The mounting bracket is attached using two screws and the thermostat can then be snapped into place on the mounting bracket as shown in Figure 15.
2. Once the wiring harness is connected, it is best to insert the thermostat on the bottom snaps first; then press down on the top of the mounting bracket as the top is snapped into place.

To remove a thermostat:

1. Press down on the top of the mounting bracket to release the snaps and pull the top of the thermostat away from the wall; then lift up to completely remove from the bracket.

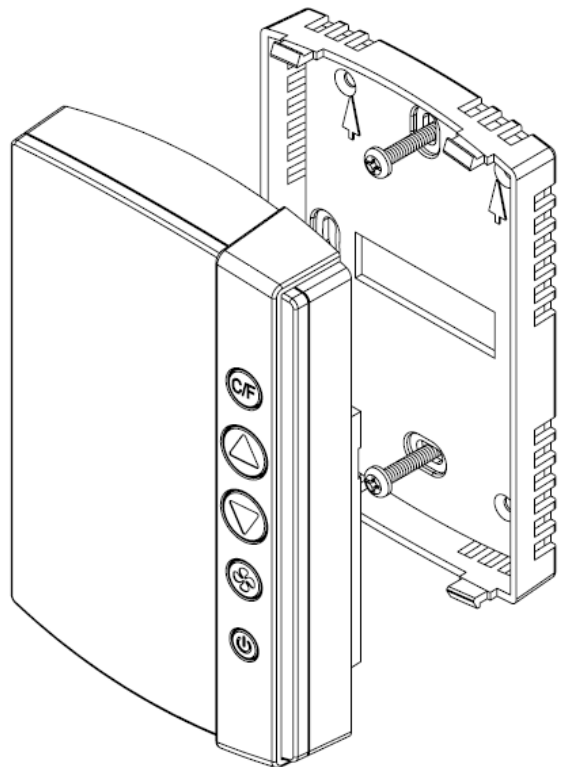

Figure 15

4.3.1.1 Thermostat placement

If there are no existing thermostats, a few important items should be considered in determining placement:

- Do not mount the thermostat in the direct air flow of the air handler.
- Do not mount the thermostat in direct sunlight.
- Do not mount the thermostat directly above or behind any heat generating device such as a light or a TV.
- Generally, the thermostat should be mounted about 1.5m (5 feet) above the floor for standard rooms; however, local codes must be followed.

Note: When applicable, also follow local handicap requirements.

4.3.1.2 Thermostat battery exchange

To exchange the batteries in the thermostat, remove the thermostat according to section 4.3.1 and exchange the batteries (3 AA) in the battery package.

4.3.2 Wiring a thermostat

4.3.2.1 Recommended wire specification

It is recommended to use 0,82 – 0,33 mm² / 18 – 22 AWG (equivalent) solid copper wire (Plenum rated if required by local code) from the thermostat to the HVAC system or *line to low voltage interface*. The same can be used if installing a wired door switch. The number of conductors to the HVAC system will depend on the particular installation. A 2-conductor wire is required for the wired door switch.

4.3.2.2 Connecting a thermostat

The wires of the wiring harness (Figure 10) are to be connected to the low voltage thermostat inputs of the air handler. These include heat, cool, three fan speeds and the reversing valve (heat pump only).

Note: If connecting to an air handler that has only two fan speeds, connect the low fan to the Fan 1 output and the high fan to the Fan 2 output. If the air handler has only one fan speed, connect to the Fan 1 output.

Important: If connecting to a high voltage air handler, a *line to low voltage conversion kit* must be used.

W/W2 (white)	For standard systems, this controls HEAT. For heat pumps, this is connected to the Stage 2 heating element if applicable.
Y/W2 (yellow)	This controls the COOL function for standard control and the Compressor for heat pump control. (For heat pumps, this is Stage 1 heating).
G1 (green)	This controls fan speed 1 (low).
G2 (orange)	This controls fan speed 2 (medium).
G3 (dark blue)	This controls fan speed 3 (high).
RV (violet)	This controls the reversing valve (heat pump only). The logic is set by the configurable parameters when the thermostat is commissioned.
Power - Common / Ground (black)	
Power (red)	12-24V AC 15-24V DC

Table 4

4.3.2.3 Line to low voltage conversion

Figure 16 shows the wiring diagram for connecting to a *line to low voltage conversion kit*. This kit is typically located in the control box of the HVAC system or in close proximity to the unit.

Note: Local codes must be followed when installing the *line to low voltage conversion kit*.

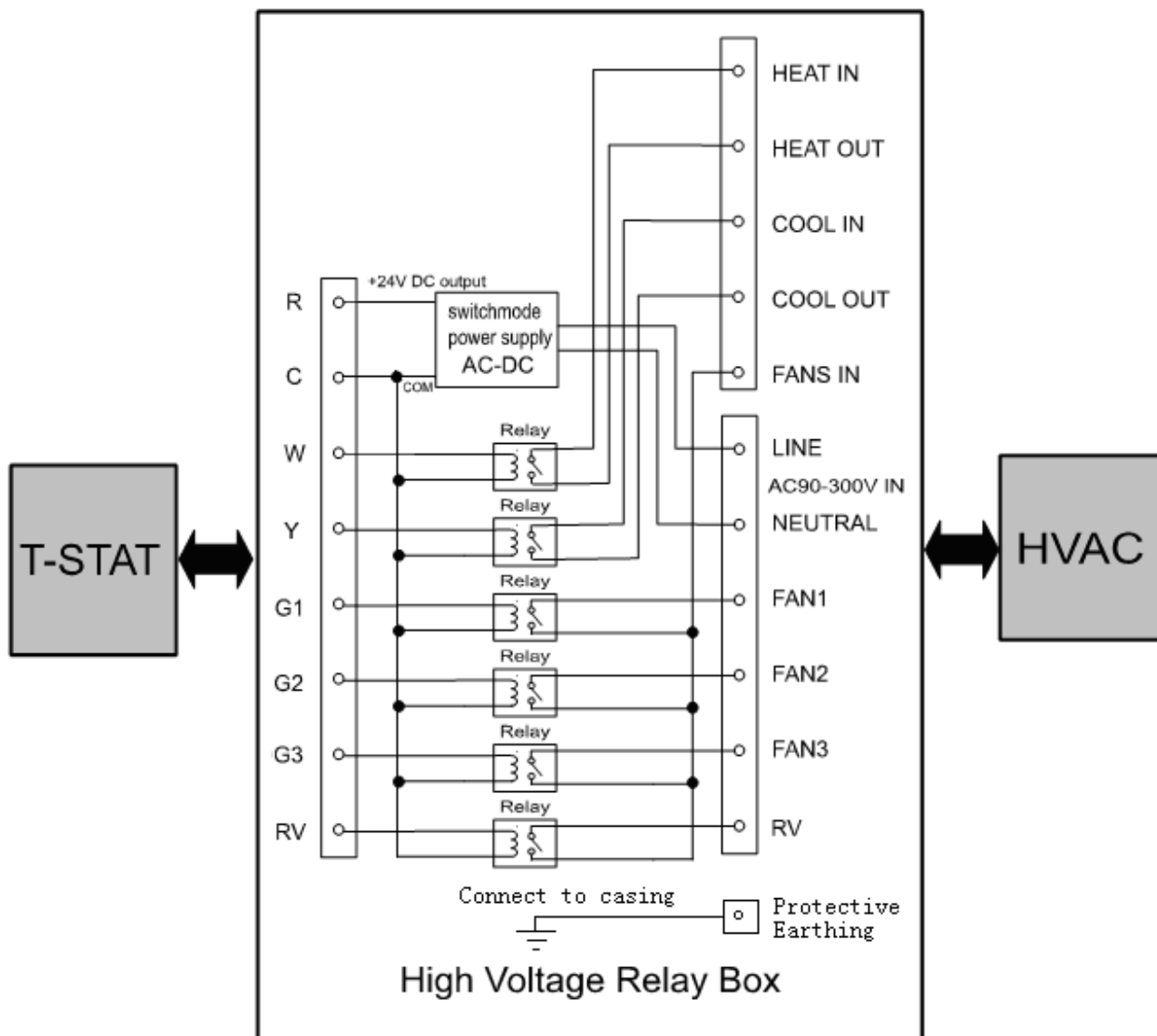

Figure 16

4.3.2.4 Connecting a wired door switch

If a wired door switch will be used to monitor the position of the door, it is recommended to use a magnetic 2-wire door switch. These wires are connected to the thermostat wiring harness as follows:

- If the door is exterior (leads to the outside), connect the wires to the orange/blue (exterior door input) wire and the white/black wire of the thermostat wiring harness.
- If the door is interior (leads to an interior corridor), connect the wires to the gray (interior door input) wire and the white/black wire of the thermostat wiring harness.

Installation of the door switch will vary depending on the type of switch used. Follow the instructions provided with the door switch to install it at the door.

4.4 Installing a motion sensor

The motion sensor is a battery operated device that may be installed on the ceiling or wall. The mounting bracket is installed with two screws as shown in Figure 17.

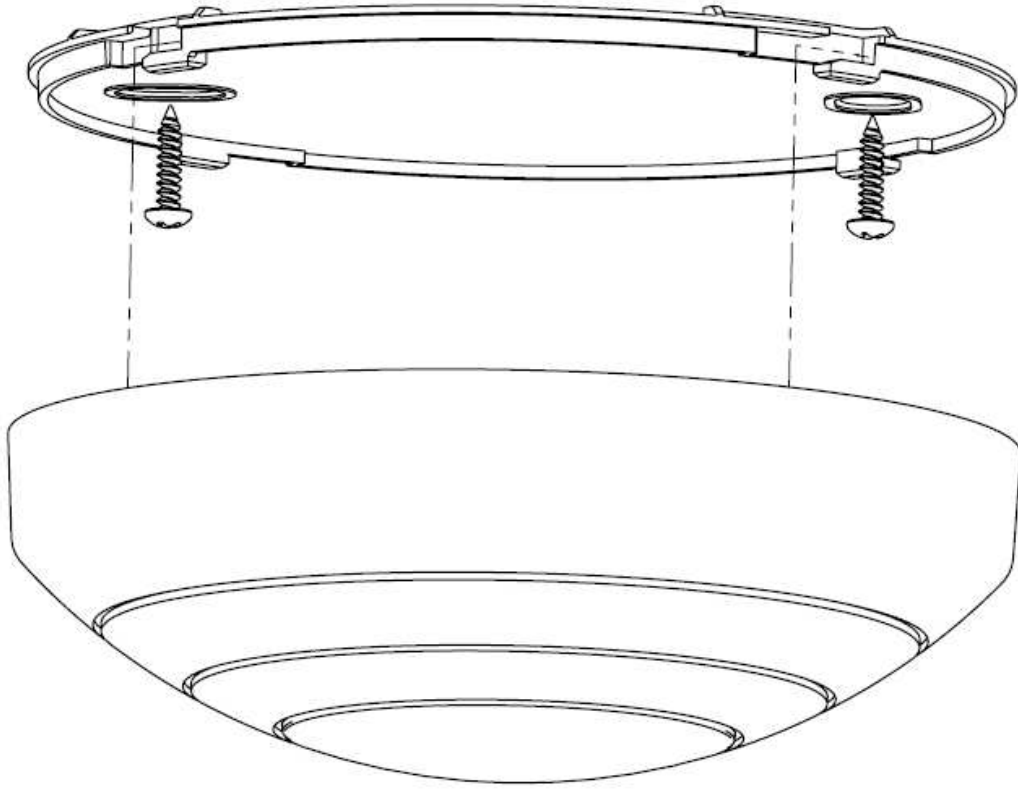

Figure 17

4.4.1 Motion sensor placement

For optimal coverage, the motion sensor should be installed on the ceiling as close to the middle of the room as possible. When ceiling mounting is not feasible, either due to the construction or for the aesthetics of the room, the sensor may be placed on the wall. The location should be as high as possible and give as much coverage to the room as possible. Figure 18 shows the range of the motion sensor when placed on the ceiling. This range is somewhat reduced when installed on the wall. The range shown is a general guideline, and the sensor is designed to cover an area of about 8m (26 feet) in diameter.

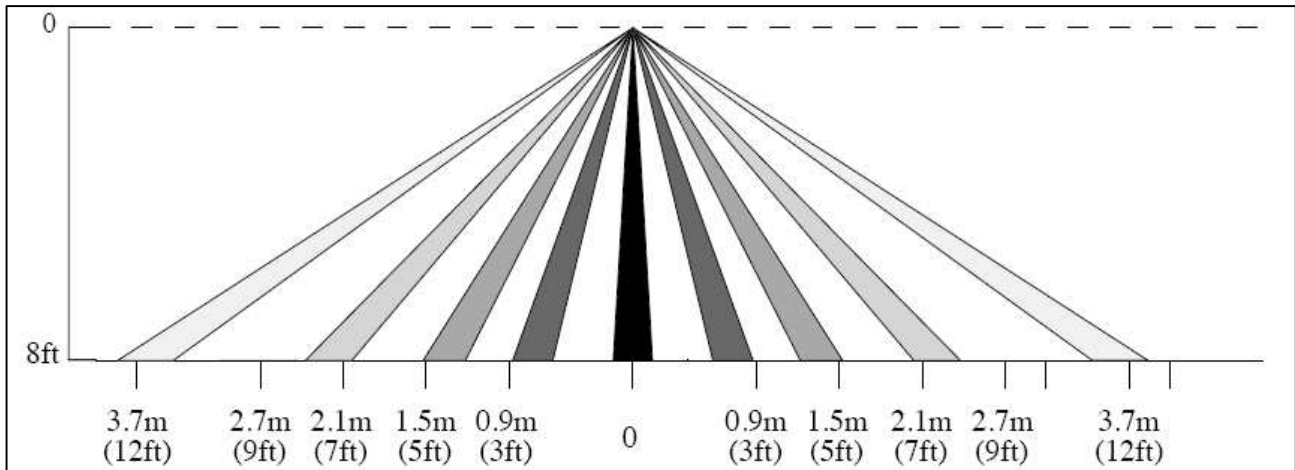

Figure 18

To check the placement, it is advisable to activate the motion LED using the service device and test the range of the motion sensor. This process will help to determine the best location of the sensor. See section 4.6 *Testing the In-Room Devices* for instructions on this process.

4.5 Commissioning the system

Before the devices can communicate, they must be joined to the ZigBee network. For detailed instructions and rules on this network, see *User manual Online option*.

Note: The ZigBee network, including gateway and router locations, must first be specified by a qualified technician. No online setup can be done until this step is completed.

4.5.1 Commissioning when thermostat controller is used

4.5.1.1 Joining the thermostat controller to the network

1. In the **ZigBee Network** window of SysMon, right click on the applicable gateway/router and select **Permit Joining**. The gateway/router is now 'open'. It will remain in this status for approximately 15 minutes or until a *forbid join* command is executed.
2. With the gateway/router open, plug the service cable into the thermostat controller.

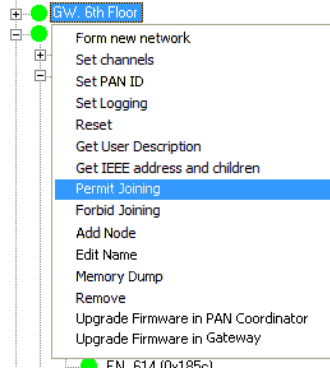

Figure 19

3. In the Orion Service software (**Start/Programs/Orion Service/Orion Service**), choose **Configure device** in the left part of the window. Let the tab **Thermostat** (default) be open and click the **Discovery** button. The thermostat controller will connect to the open gateway/router.

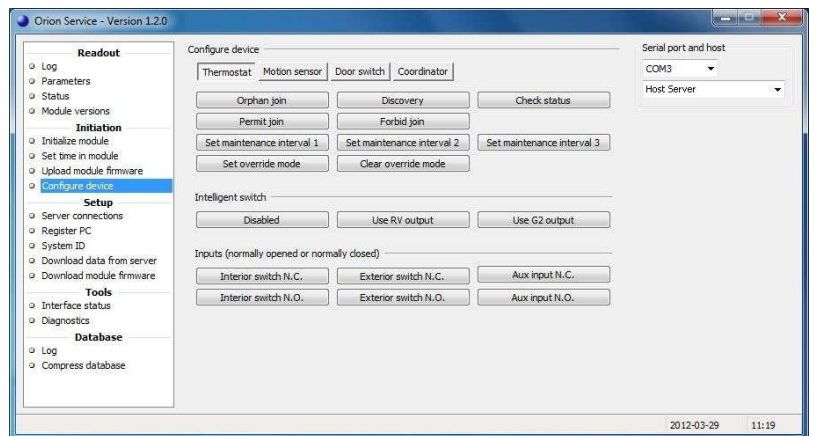

Figure 20

4. To see if the thermostat controller was able to join the network, click the **Check status** button in the **Configure Device** section of Orion Service. If the joining was successful, the message 'Device is online' is shown.
5. With the thermostat controller joined to its gateway/router, right click on the gateway/router in SysMon and select **Forbid Joining**.

4.5.1.2 Joining the in-room devices to the thermostat controller

The next step is to join the *in-room devices*, e.g. thermostats, motion sensors and locks (or RF door switches, if this is applicable).

Note: When the thermostat controller is applicable, the thermostat has an *endnode firmware*. The thermostat controller has either a *router firmware* or a *coordinator firmware*, depending on scenario. The *coordinator firmware* is for offline scenarios when there is no connection to the server; see *Appendix C* for details about setting up the in-room network in that case.

1. Plug the service cable into the thermostat controller.
2. Click the **Permit Join** button in the **Configure device** section (**Thermostat** tab) of Orion Service; see picture in 4.5.1.1.

Note: The thermostat controller will remain open for 15 minutes or until a *forbid join* command is received.

3. Once the thermostat controller has been opened for joining, plug the service cable into the applicable in-room device. Choose the **Motion sensor** tab in the **Configure device** section of Orion Service; click the **Discovery** button.
4. Wait a few seconds and then click the **Check status** button. If the device has joined successfully, the message 'Device is online' is shown. If that message is not displayed, wait a few more seconds and check the status again. If the device is still offline, repeat the discovery process.
5. Join the lock and use an *Enable EMI events card* in it; details are found in the section *Enabling EMI events via card* in *Appendix C*.
6. If an RF door switch is applicable instead of a lock, repeat steps 3-5 with the RF door switch; in step 4, use the **Door switch** tab.
7. Click the **Forbid join** button under the **Thermostat** tab in the **Configure device** section of Orion Service; see picture in 4.5.1.1.
8. Test the in-room devices; details are found in section 4.6.

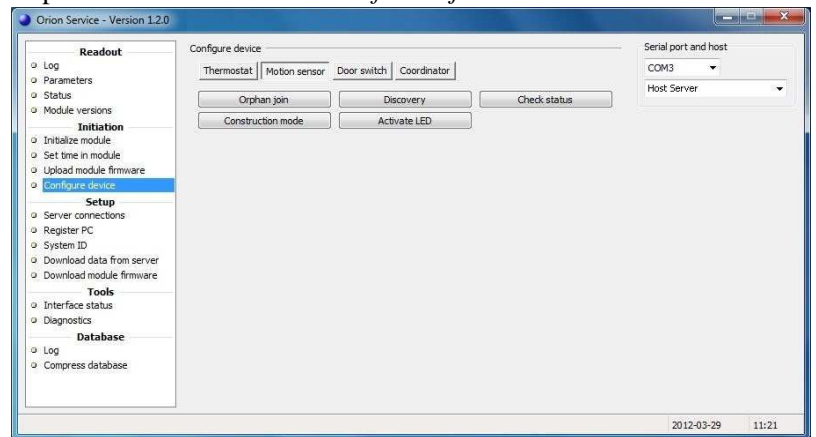

Figure 21

4.5.2 Commissioning when thermostat controller is not used

The thermostat is equipped with a ZigBee endnode which can have either *router firmware* or *coordinator firmware*. The coordinator firmware is for offline scenarios when there is no connection to the server; see *Appendix C* for details about setting up the in-room network in that case.

The thermostat may be joined directly to a gateway, router or another thermostat as specified in the network layout. The thermostat is the primary device in the room, and the lock and motion sensor will be joined to this thermostat. When the steps in sections 4.5.2.1 and 4.5.2.2 have been performed, the in-room network is operational.

Note: To use the Orion Service software which is mentioned in step 4 below, connections to the application server must be made according to *Appendix A*.

4.5.2.1 Joining the thermostat to the network

1. To be able to join the thermostat to the gateway or router, it is first necessary to permit joining on the gateway or router. This is done in the SystemMonitor, *SysMon*; to open this, double click on **SysMon.exe** in the software installation folder and log on at **File/Log on**. In SysMon, choose **View/ZigBee** to see the ZigBee network. Right click on the designated gateway/router in the **ZigBee Network** dialog and select **Permit Joining** in the right-click menu; see Figure 22.

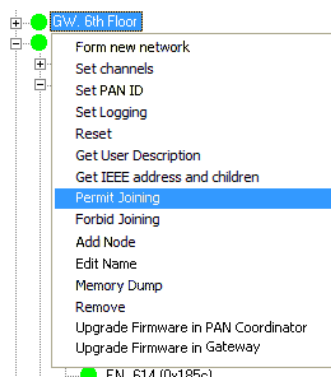

Figure 22

2. When the gateway/router has been set in the permit joining mode, it is “open”. It will remain in this status for approximately 15 minutes or until a *forbid join* command is executed.
3. With the gateway/router open, plug the service cable into the thermostat.

4. In the Orion Service software (go to **Start/Programs/Orion Service/Orion Service**), choose **Configure device** in the left pane of the window. Let the tab **Thermostat** (default) be open and click the **Discovery** button; see Figure 23. The thermostat will connect to the open gateway/router.

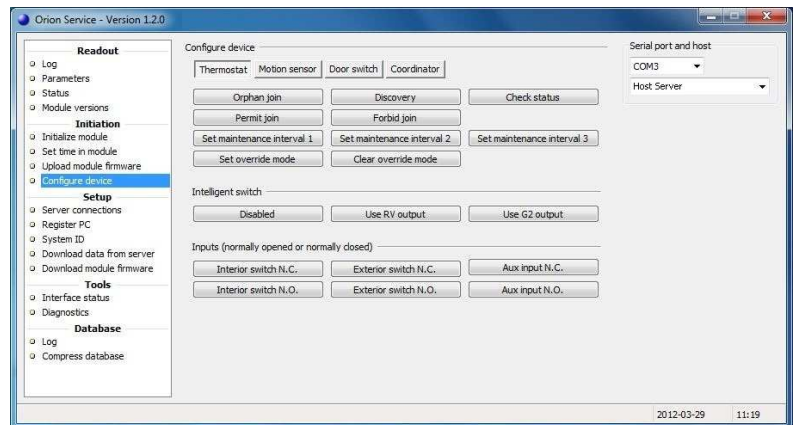

Figure 23

5. To see if the thermostat was able to join the network, click the **Check status** button in the **Configure Device** section of Orion Service. If the joining was successful, the message ‘Device is online’ is shown.
6. With the thermostat joined to its gateway/router, right click on the gateway/router in SysMon and select **Forbid Joining**.

4.5.2.2 Joining the in-room devices to the thermostat

Next, the *in-room devices* must be joined to the thermostat, e.g. motion sensors and locks (or RF door switches, if this is applicable).

1. Plug the service cable into the thermostat.
 2. Click the **Permit Join** button in the **Configure device** section of Orion Service; see Figure 24.
- Note:** The thermostat will remain open for 15 minutes or until a **Forbid Join** command is received.

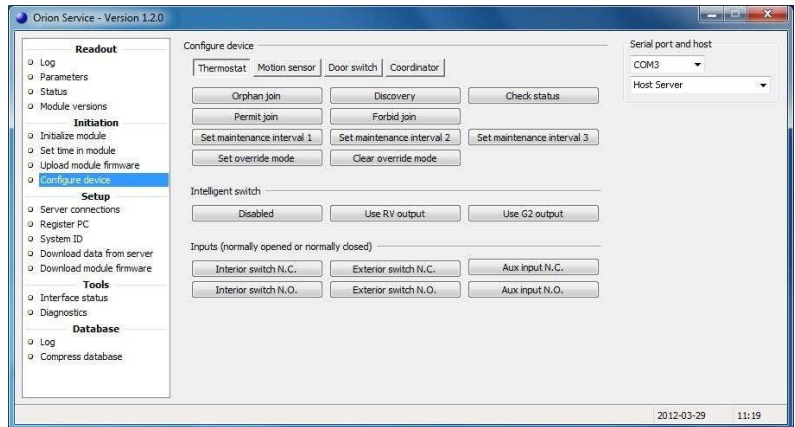

Figure 24

3. Once the thermostat has been opened for joining, plug the service cable into the motion sensor.
4. Choose the **Motion sensor** tab in the **Configure device** section of Orion Service. Click the **Discovery** button; see Figure 25.

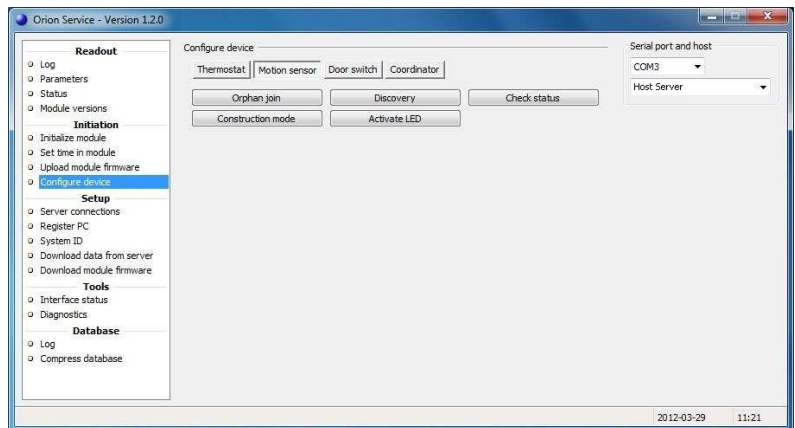

Figure 25

5. Wait a few seconds and then click the **Check status** button in the **Motion sensor** tab of **Configure device**; see Figure 26. If the device has joined successfully, the message 'Device is online' is shown. If that message is not displayed, wait a few more seconds and check the status again. If still offline, repeat the discovery process.

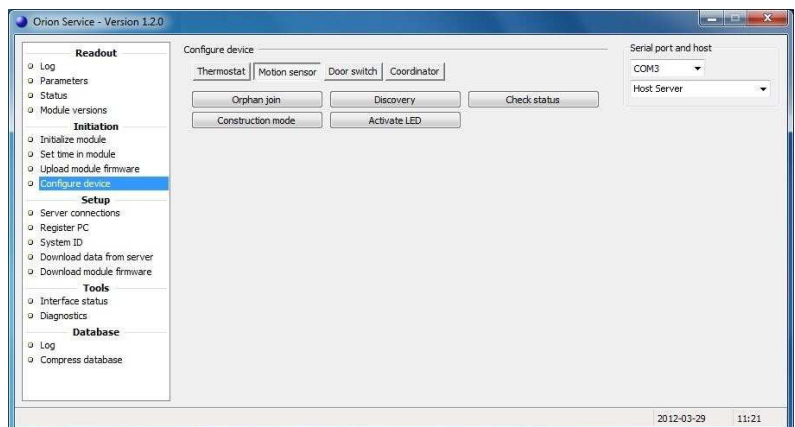

Figure 26

6. The lock is joined to the thermostat by using a *Discovery card* (one of the ZigBee configuration cards; see *User manual Online option* for information about issuing the card). For mag/smart locks the card is inserted into the card reader, and for RFID locks the card is placed against the reader. There will depending on lock model be a green flash and/or a chirp, indicating that the lock has been set into discovery mode. Wait a few seconds and then present the *Check Status card* (one of the ZigBee configuration cards) at the lock. If the light flashes the green light only and/or a chirp is heard, the lock has successfully joined the network. If you instead see a green flash followed by red flashes, and/or a beep is heard, the lock has not joined. In this case, wait a few seconds and then try the *Check Status card* again. If still not successful, repeat the discovery process.
7. In order for the lock to send door events to the thermostats, EMI events must be enabled. This is achieved by presenting an *Enable EMI events card* (one of the ZigBee configuration cards) at the lock.
8. If an RF door switch is applicable instead of a lock, repeat steps 3-5 with the RF door switch; in step 4, use the **Door switch** tab.
9. Once the devices have been successfully joined, plug the service cable into the thermostat.
10. Choose the **Thermostat** tab of the **Configure device** section in Orion Service. Click the **Forbid Join** button; see Figure 27. Failure to perform this step will result in problems when setting up the network in nearby rooms.
11. Right click on the thermostat and choose **Get user description**. Make sure that the description says 'no' at 'Join permitted'.

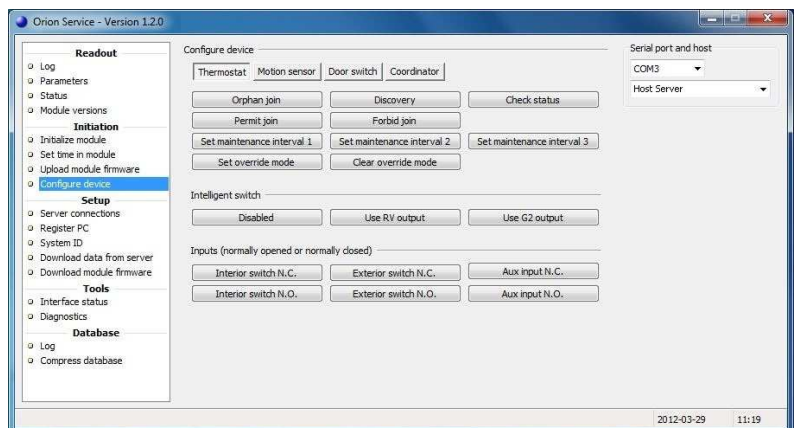

Figure 27

4.6 Testing the in-room devices

With the network successfully formed, it is now possible to test the devices to ensure proper functionality.

1. Open and close the door.
2. Engage and disengage the deadbolt.
3. Walk around the room to ensure a motion event.
4. Run an event log of the thermostat using the service device. To make this, plug the service cable into the thermostat, choose the **Log** section under **Readout** in the left part of the Orion Service window, choose the applicable **No. of events** and click the **Readout** button. Ensure that the door and motion events are logged as shown in the example in Figure 28.

#	Time	Event name	Event number	Room temperature	Set temperature
65	3/5/2010 12:15 PM	HVAC turned on. Cooling	72	74° F	70° F
64	3/5/2010 12:15 PM	Deadbolt released	30	74° F	70° F
63	3/5/2010 12:15 PM	Set-point reached first time	20	70° F	70° F
62	3/5/2010 12:15 PM	Occupancy status changed to occupied	18	70° F	70° F
61	3/5/2010 12:15 PM	Deadbolt thrown	29	70° F	70° F
60	3/5/2010 12:15 PM	Occupancy status changed to unoccupied	17	70° F	70° F
59	3/5/2010 12:15 PM	Thermostat reset	70	70° F	70° F
58	3/5/2010 12:15 PM	Door closed	31	74° F	70° F
57	3/5/2010 12:15 PM	Occupancy status changed to unoccupied	17	74° F	70° F
56	3/5/2010 12:15 PM	Door opened from the inside	28	74° F	70° F
55	3/5/2010 12:13 PM	Motion detected	21	74° F	70° F
54	3/5/2010 12:13 PM	HVAC turned on. Cooling	72	74° F	70° F
53	3/5/2010 12:13 PM	Occupancy status changed to occupied	18	70° F	70° F
52	3/5/2010 12:13 PM	Motion detected	21	70° F	70° F

Figure 28

5. Run a status check by selecting the **Status** section in the left part of the Orion Service software window, making sure that the service cable is plugged into the thermostat and clicking the **Readout** button. Make sure that the motion sensor, lock and thermostat all say 'Offline: No'; see Figure 29.

Status flags
Occupancy: Unoccupied
Freeze guard active: no
Motion error: no
HVAC runtime error: no
Maintenance interval 1: no
Maintenance interval 2: no
Maintenance interval 3: no
Battery alarm (motion sensor): no
Battery alarm (thermostat): no
Door error: no
Motion sensor offline: no
Lock offline: no
Thermostat offline: no
Excessive occupancy: no
Fan in auto mode
Fan set to 3
HVAC cooling
Thermostat: on

Figure 29

6. Test the range of the motion sensor. First, make sure that the door is open as this will ensure that the motion sensor is not deactivated by the thermostat.
7. Go to the **Configure device** section in the left part of the Orion Service software window and choose the **Motion sensor** tab. Make sure that the service cable is plugged into the motion sensor and click the **Activate LED** button; see Figure 30.

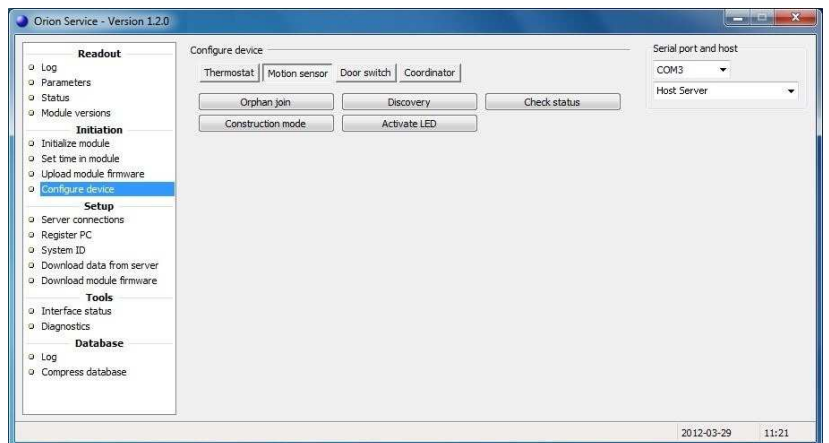

Figure 30

8. Walk around the room; the LED of the motion sensor will light up as motion is detected. Ensure that the range is sufficient to pick up motion in the room. The LED will be active for 10 minutes and then automatically turn off.
9. The system is now ready for use.

Appendix A: Orion Service connections

The service device is connected to the server via LAN, and to the *USB interface* via a USB port. When communicating with a thermostat/motion sensor/RF door switch, a *service cable* is connected to the *USB interface*.



USB interface

Art. No: 686 001 026



Service cable

Art. No: 205 999 005

There are two variants of *USB interface*. The appearance of the item is the same in both cases, but in Orion Service it looks different at ‘Serial port and host’ (see screenshots below) depending on what variant that is used.

Note: For setup of the host server, see *Server connections* below. For more information about choosing serial port and server, see section *Register PC* in this appendix.

- With the first variant, Orion Service accesses the *USB interface* through a virtual COM port. Drivers must be installed to enable the communication between service device and *USB interface*. The drivers are called *CP210x USB to UART Bridge Virtual COM Port (VCP)* and can be downloaded for free from the Silicon Labs web site. They are also included on the software CD.

Note: Installation of the drivers must be made before connecting the *USB interface* to the service device. Once the drivers have been installed, the *USB interface* must always be connected to the service device when Orion Service is running.



- With the newer variant of *USB interface*, the communication between service device and *USB interface* is taken care of by the USBXpress driver. The *USB interface* is configured for this at delivery and no drivers need to be installed. The first connected *USB interface* will be called USB0, the second one USB1 etc.



Note: The screenshots in this manual from now on only show the case with virtual COM port at ‘Serial port and host’ in the upper right corner.

Server connections

To connect a service device to the server, there must be a service device host in the device list of the software.

Note: The service device host must be added to a PC with static IP address. See section *Set up a service device* in this appendix for information on how the service device host is set up in the software.

1. To add a connection, click the **Add** button and enter server data.
2. To remove a connection, select the connection and click the **Delete** button.

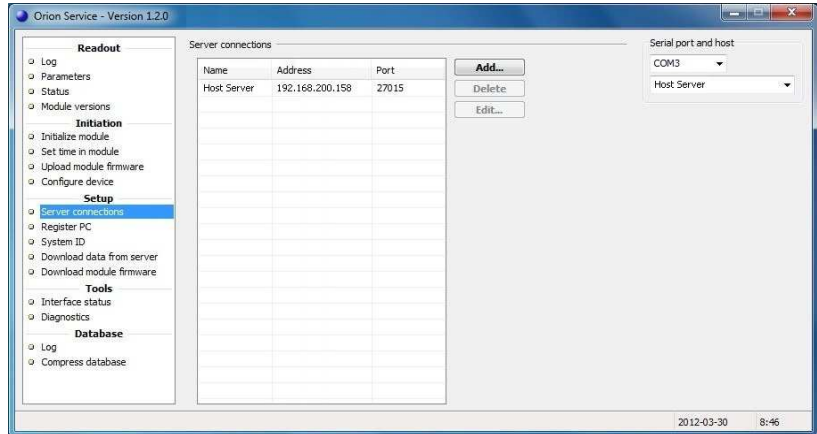

3. To edit a connection, select the connection and click the **Edit** button. The dialog to the right is shown; enter the new information and click **OK**.



4. In the upper right corner of the Orion Service window, click **R** to refresh the dialog and choose the COM port which says 'Silicon Labs CP210x...'



Register PC

The service device must be authenticated with a registration code in order to connect with the server. The registration code is generated from the software; see section *Set up a service device* in this appendix for details.

Note: This procedure is only needed once.

1. Enter the **Code**.
2. Enter a **Note**; this is optional.

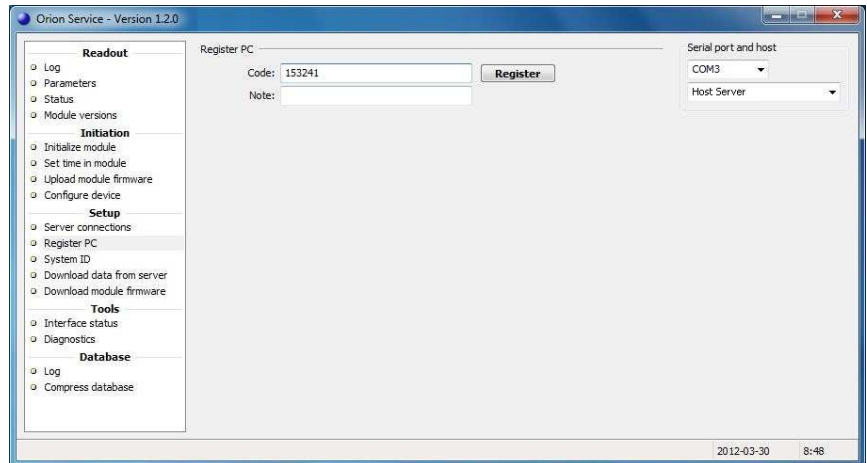

3. Choose serial port and server for the *USB interface*.



4. Click the **Register** button.

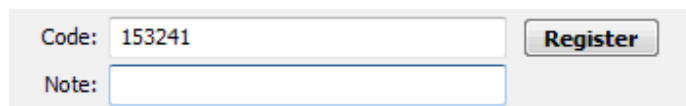

Set up a service device

Before a service device with Orion Service can be used, a service device host must be available in the device list of the software. The service device must also be registered with a registration code which is generated in the software.

To add a service device host to the device list:

1. Double click on **Devices** under the **Lists** tab in the navigation window.
2. In the **Devices** dialog which is shown, click **Add** to add a new service device host to the system. The **Device details** dialog is shown.
Note: If desired, mark the 'Wizard mode' check box to get more detailed help.
3. Enter a **Name** for the service device host.
4. At **Type**, choose "Service device host".
If possible, use the default port.
5. Choose **Location** for the service device; normally 'Server' should be chosen.
If there are firewalls in the system, 'Computer' could be chosen – in this case, also enter the computer name.
Note: In some cases, several devices might be needed due to firewalls etc.
6. Click **Save**, or **Update** if an existing service device host was redefined.
7. Click **Close**.

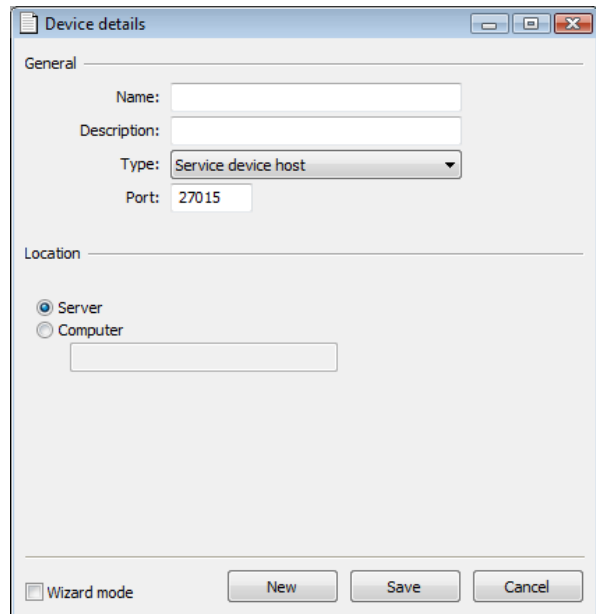
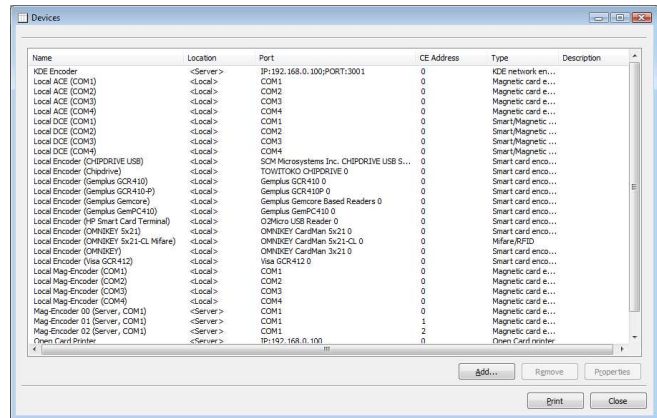

To register the service device:

1. Double click on **Service devices** under the **Lists** tab in the navigation window.
2. In the **Service devices** dialog, click **Add**.
3. A registration code is generated and shown in a dialog. The code has to be keyed into the service device within a given time interval; see section *Register PC* in this appendix for details. When this is done, the service device will pop up in the service device list and will be ready for use.

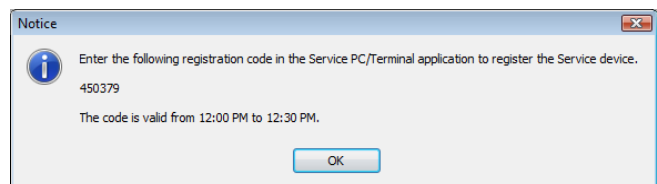
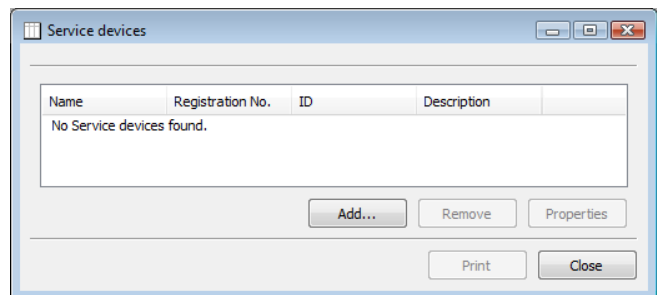

Appendix B: Firmware upgrade

At delivery, the thermostat and the motion sensor contain the correct module firmware. However, if a firmware upgrade is needed at a later occasion, the service device with Orion Service is used. There are two ways to download the module firmware to Orion Service:

- The first method is to save the module firmware on the VISIONLINE server, and then download it from there to Orion Service
- The second method is to upload the module firmware from e.g. a USB memory

Note: Upgrading the end node firmware in the thermostat may take several minutes.

Note: If thermostat controller is applicable, and the firmware in this as well as in the thermostat should be upgraded at the same time, it is recommended to start upgrading the thermostat controller first.

To first save the firmware on the VISIONLINE server and then download it from there to Orion Service:

1. Go to **Tools/Module firmware** in the VISIONLINE software. The dialog to the right is shown.

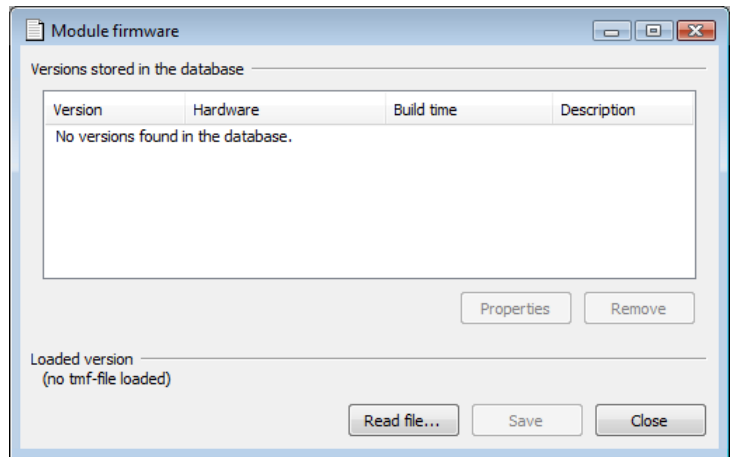

2. Click **Read file** and browse to the applicable module firmware file; tmf file.
3. Mark the tmf file and click **Open**. The tmf file will be read into the memory and the tmf version will appear at "Loaded version" in the lower left corner of the **Module firmware** dialog.

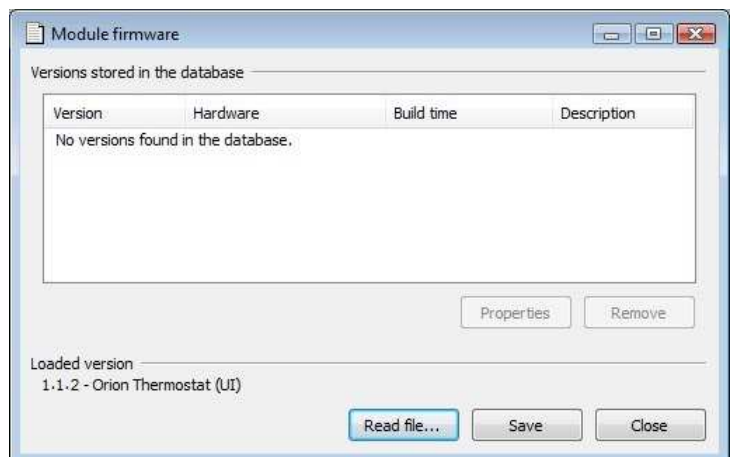

- Click **Save** to store the tmf version in the database. The version will appear in the list below “Versions stored in the database” in the **Module firmware** dialog.

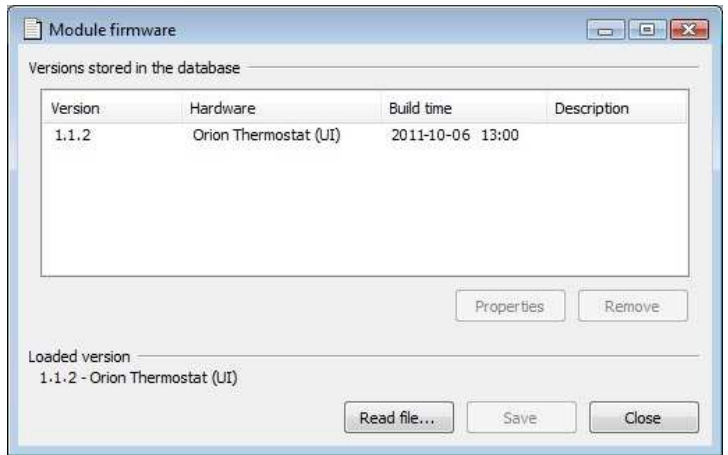

- To enter an optional description for the tmf version, mark the version in the **Module firmware** dialog and click the **Properties** button. The **Additional note** dialog to the right is shown. Enter a description and click **OK**.

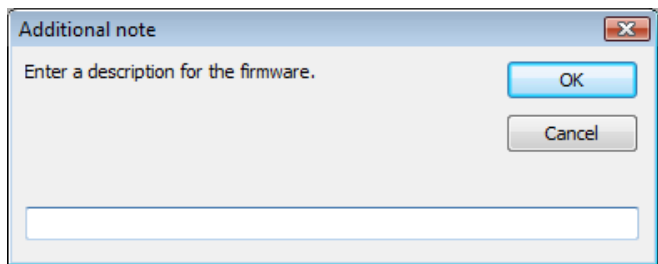

- In the Orion Service software, choose **Download module firmware**. Click **Query** to list the available module firmware versions on the VISIONLINE server.
- Mark the applicable firmware version and click **Download**.
- If applicable, repeat step 7 with other firmware that is to be uploaded.
- Plug the service cable into the thermostat or motion sensor, depending on which module that is to be upgraded.

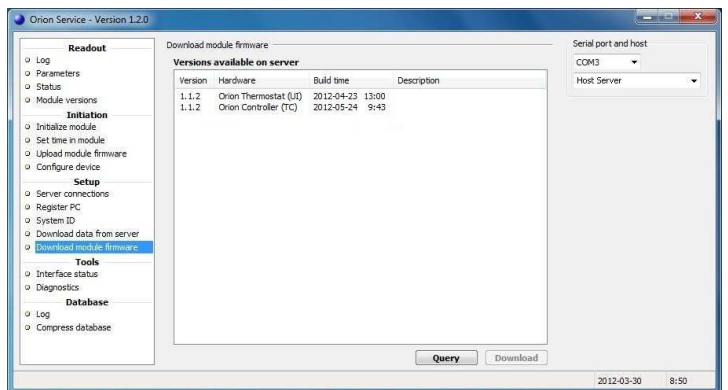

- In the Orion Service software, choose **Upload module firmware**. The firmware version(s) that have been downloaded according to step 7 above will be shown. Mark the applicable firmware version and click **Upload**.

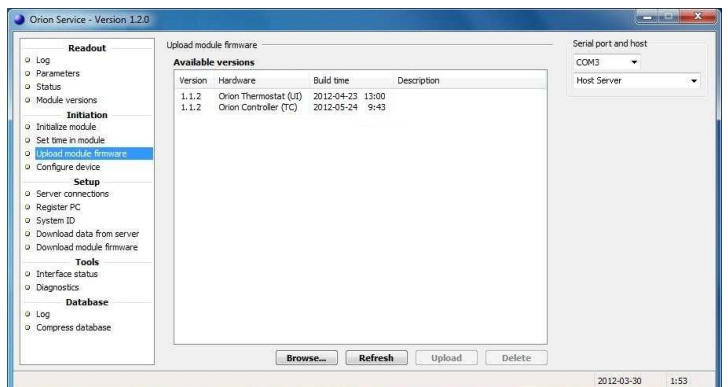

To upload the module firmware directly from a USB memory etc:

1. In the Orion Service software, choose **Upload module firmware**.

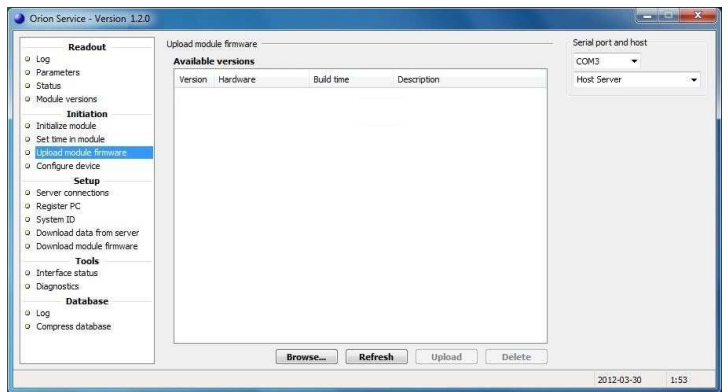

2. Click **Browse** and browse to where the applicable firmware file is located. Mark the file and click **Open**.

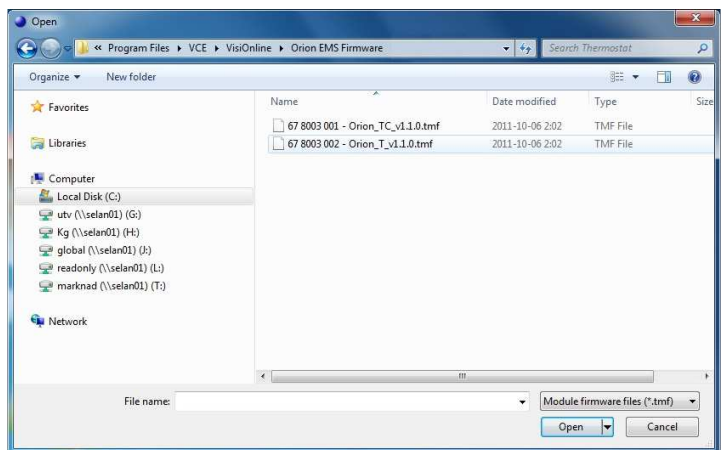

3. To save the firmware file to the database, right click on it and choose **Save to database**.

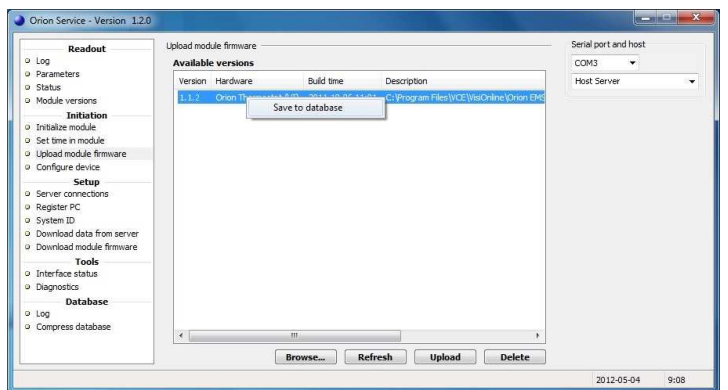

4. Down to the left in the **Lock Service** window, it will be shown how far the save process has reached. When the firmware has been successfully saved, there will be an alert about this.

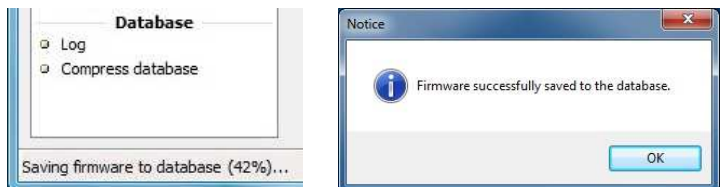

- To add/edit the description for the firmware, right click on the firmware when it has been saved to the database and choose **Edit description**.

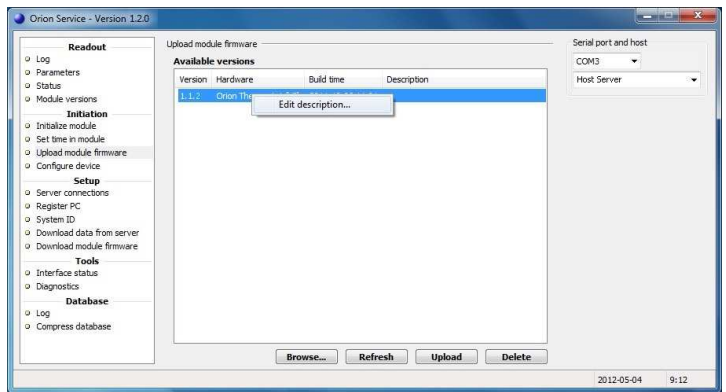

- Write the applicable description and click **Enter**.



- To upload new module firmware to the lock, select module version in the **Available versions** list and click the **Upload** button.

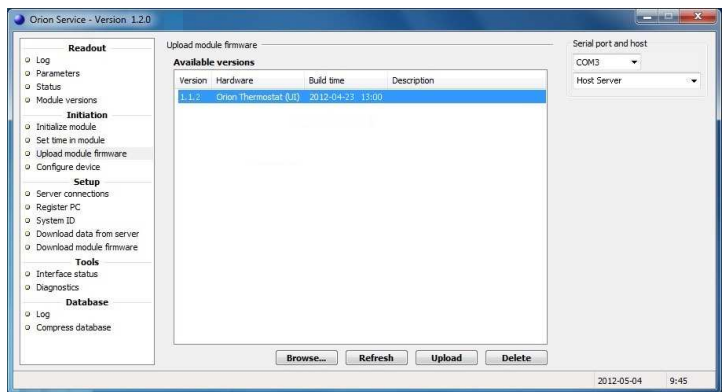

Appendix C: Configuration in offline scenarios

In Orion EMS offline scenarios, there is no connection to the VISIONLINE server. Either a *wired thermostat* or a *thermostat controller* and a *battery thermostat* is used. Each room can be seen as a PAN (*personal area network*) which is controlled by its wired thermostat or its thermostat controller, depending on what scenario that is applicable.

The firmware in the wired thermostat or the thermostat controller is a *coordinator firmware* instead of a *router firmware*.

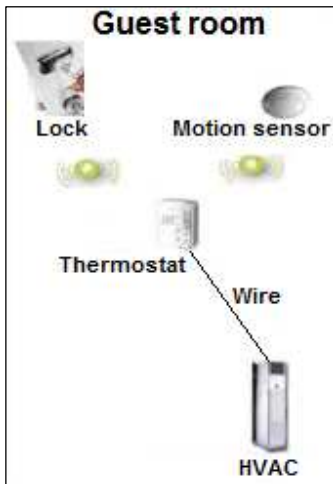

Figure C1: Offline scenario with wired thermostat

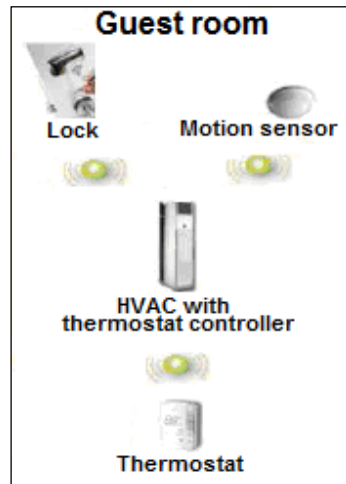

Figure C2: Offline scenario with thermostat controller and battery thermostat

The RFID lock in the configuration pictures above must be prepared in two ways:

- it must be online with the in-room network; see the applicable one of sections *Scenario with wired thermostat* and *Scenario with battery thermostat*.
- EMI events must be enabled in the lock. This can be done either with an *Enable EMI events card* or via Lock Service; see the applicable one of sections *Enabling EMI events via card* and *Enabling EMI events via Lock Service*.

Note: The EMI events will be sent to the closest parent in the in-room network, since there is no connection to the VISIONLINE server.

Adding the lock to the in-room network

The in-room network is configured under the **Configure device** section in Orion Service.

Configuration	Description
Form new network	This configuration removes all nodes in the PAN and resets the coordinator.
Permit join	When this configuration is used, an in-room device (RF door switch, motion sensor or lock) can join the coordinator.
Forbid join	When the RF door switch, motion sensor or lock has joined the coordinator, this configuration should be used on the coordinator. Note: If the Forbid join command is for some reason forgotten, it will automatically be executed 15 minutes after the Permit join command was executed.
Set channels	Default is that all channels are ON (the '1' indicates ON); the best channel will automatically be chosen, so normally the Set channels command is not needed.
Get network	This configuration shows the in-room network. Note: When hovering with the cursor over an item in the network, the tooltip will show what type of item it is; e.g. 'Coordinator' as in the screenshot example above. The tooltip will also show e.g. IEEE address and firmware version.

Scenario with wired thermostat

1. Go to **Start/Programs/ Orion Service/Orion Service**.
2. Choose **Configure device** in the left pane of the Orion Service window.
3. Plug the service cable into the thermostat.
4. Choose the **Coordinator** tab.
5. Click **Form new network**.

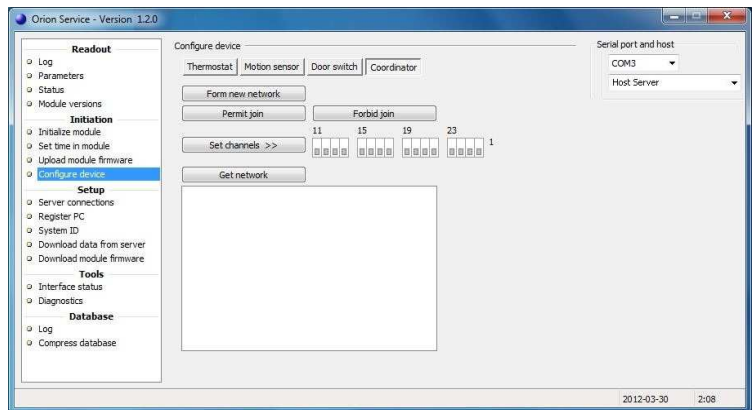

6. Click the **Get network** button; the thermostat will appear in the window below **Get network**.

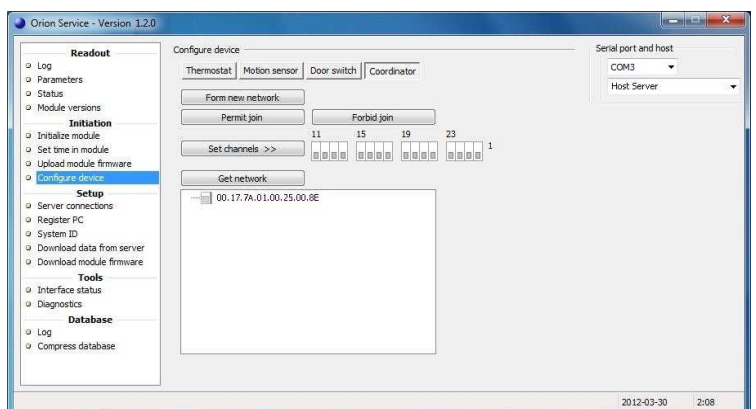

7. Put the cursor on the thermostat in the Orion Service window; an information box, showing e.g. the thermostat channel, will appear. If the channel should be changed, click the applicable channel (in the picture example '26') and click the **Set channels** button.
8. Mark the thermostat and click the **Permit join** button.
9. Right click on the thermostat and choose **Get user description**. Information about the thermostat will be shown; see picture to the right. Make sure that
 - the channel is correct
 - it says 'yes' at 'Join permitted'**Note:** If it does not say 'yes' at 'Join permitted', click the **Permit join** button again.

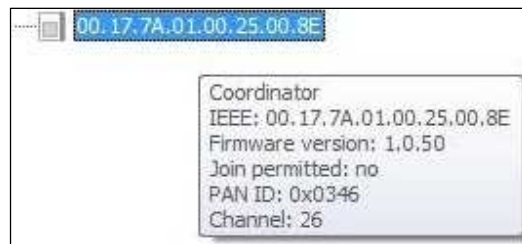
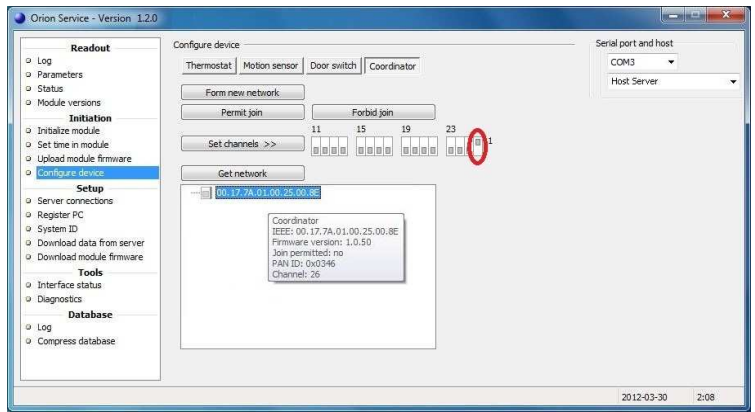

10. Plug the service cable into the motion sensor.
11. Choose the **Motion sensor** tab and click **Discovery**.

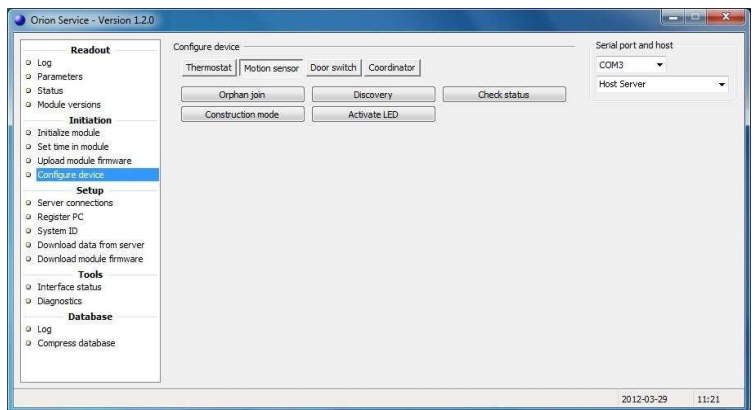

12. Plug the service cable into the thermostat.
13. Choose the **Coordinator** tab and click **Get network**.

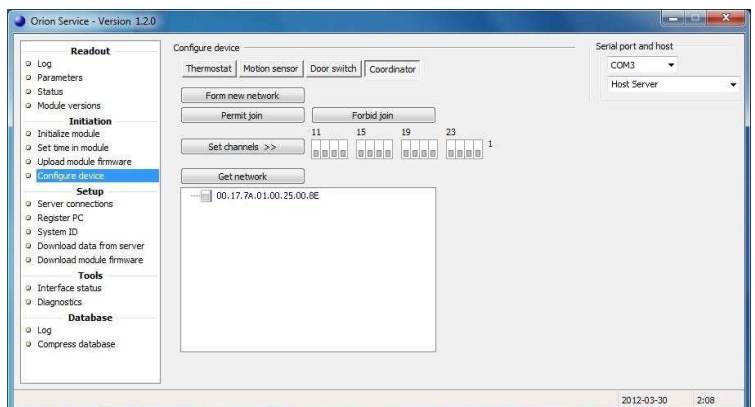

14. Click the plus sign in front of the thermostat; the motion sensor will appear in the network tree.
15. Right click on the thermostat to make sure that it still says 'yes' at 'Join permitted'.

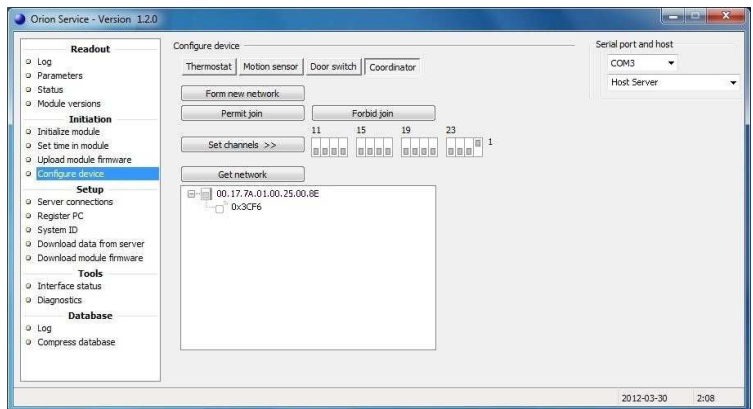

16. Issue a *Discovery card* in VISIONLINE:
 - Go to **Start/Programs/VisiOnline/VisiOnline** and log on.
 - Double click on **ZigBee configuration** under the **Cards** tab in the navigation window.
 - Browse to choose a **Card holder** and enter the applicable **No. of days**.
 - At **Type**, choose 'Start discovery in ZigBee'.
 - If applicable, tick the checkbox 'Print receipt'.
 - Click **Make card** and present a card at the encoder.
17. Present the *Discovery card* at the lock.

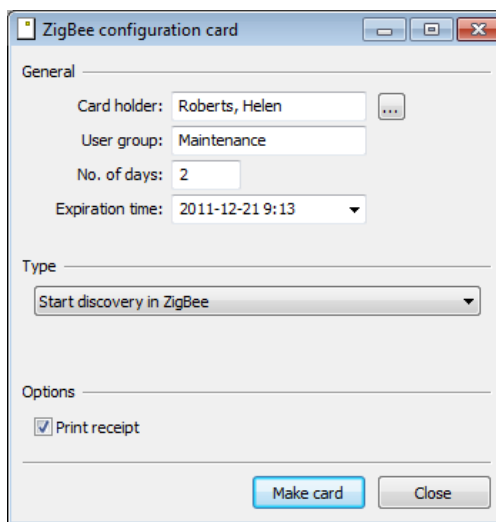

18. In Orion Service, **Configure device** section: click **Get network** under the **Coordinator** tab.

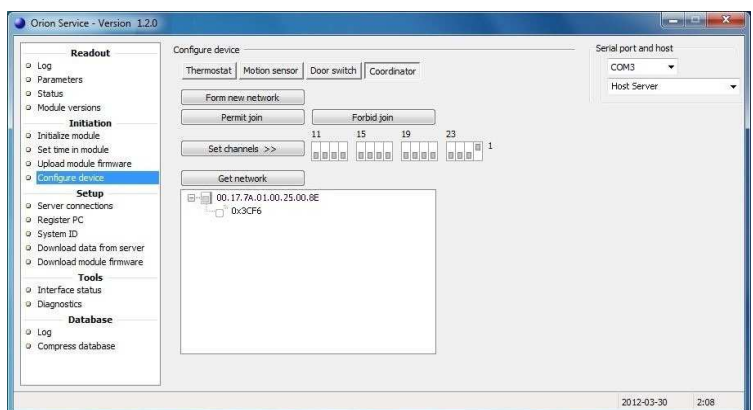

19. Click the plus sign in front of the thermostat; the lock will appear in the network tree.
20. Mark the thermostat and click the **Forbid join** button.
21. Right click on the thermostat and choose **Get user description**. Make sure that the description says 'no' at 'Join permitted'.

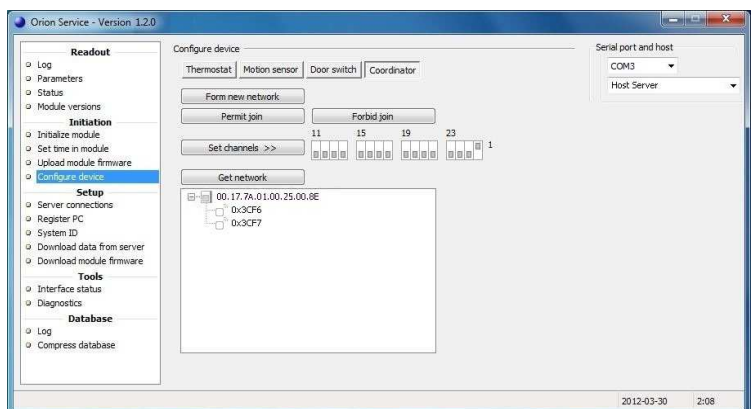

Scenario with thermostat controller and battery thermostat

1. Go to **Start/Programs/ Orion Service/Orion Service**.
2. Choose **Configure device** in the left pane of the Orion Service window.
3. Plug the service cable into the thermostat controller.
4. Choose the **Coordinator** tab.
5. Click **Form new network**.

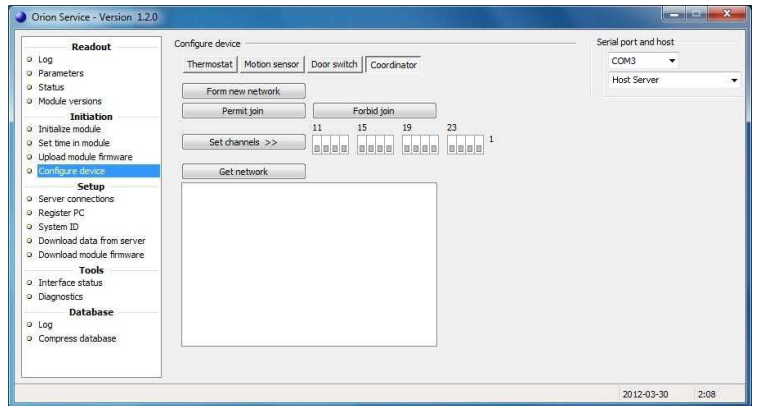

6. Click the **Get network** button; the thermostat controller will appear in the window below **Get network**.

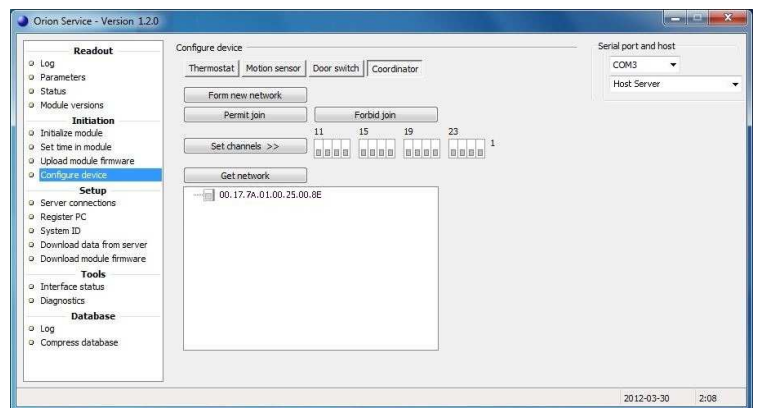

7. Put the cursor on the thermostat controller in the Orion Service window; an information box, showing e.g. the channel for the thermostat controller, will appear. If the channel should be changed, click the applicable channel (in the picture example '26') and click the **Set channels** button.
8. Mark the thermostat controller and click the **Permit join** button.
9. Right click on the thermostat controller and choose **Get user description**. Information about the thermostat controller will be shown; see picture to the right. Make sure that

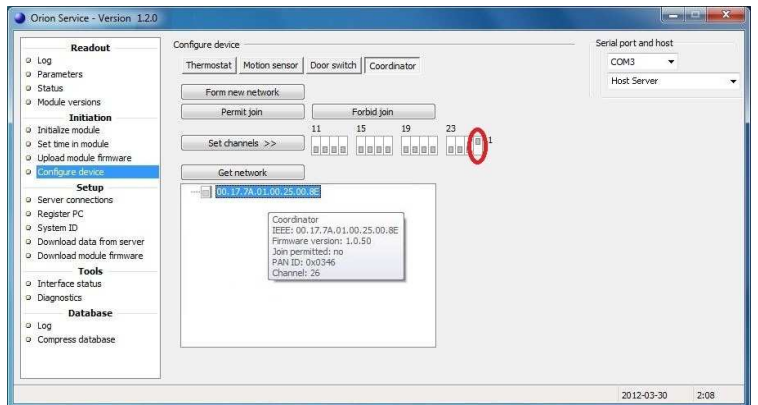

- the channel is correct
- it says 'yes' at 'Join permitted'

Note: If it does not say 'yes' at 'Join permitted', click the **Permit join** button again.

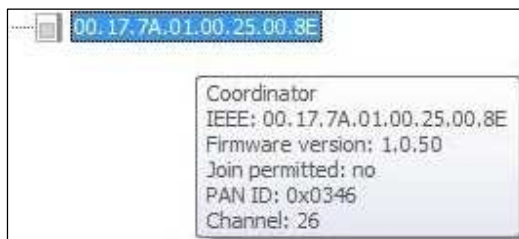

10. Plug the service cable into the battery thermostat.
11. Choose the **Thermostat** tab and click the **Discovery** button.

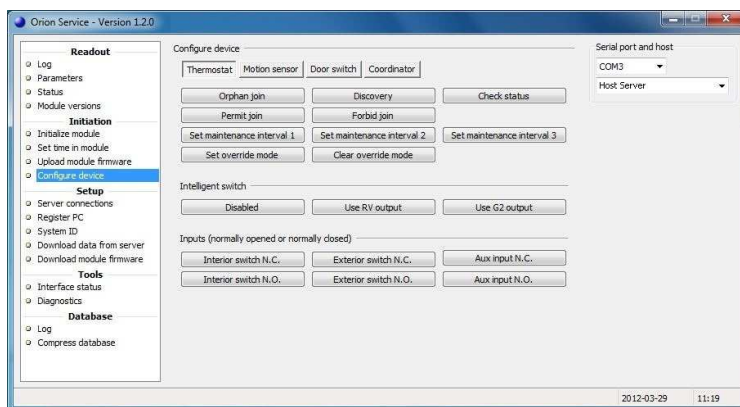

12. Plug the service cable into the thermostat controller.
13. Choose the **Coordinator** tab and click **Get network**.

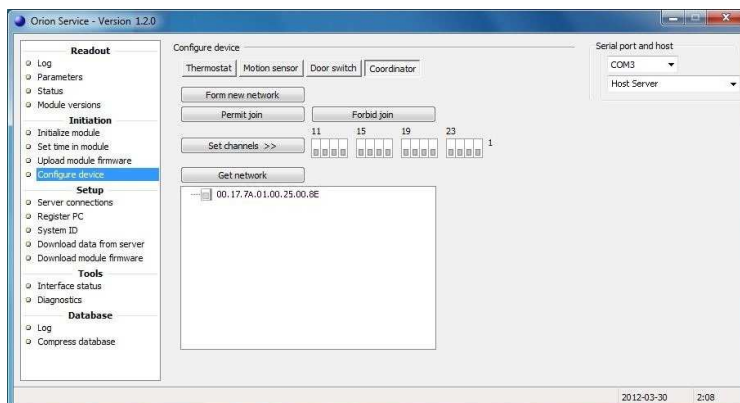

14. Click the plus sign in front of the thermostat controller; the battery thermostat will appear in the network tree.
15. Right click on the thermostat controller to make sure that it still says 'yes' at 'Join permitted'.

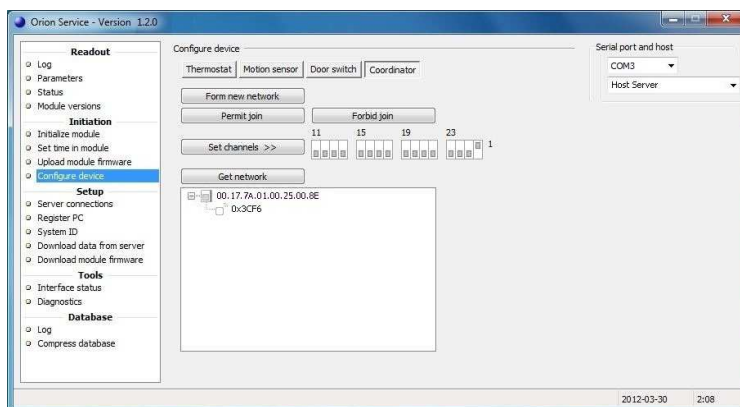

16. Issue a *Discovery card* in VISIONLINE:
 - Go to **Start/Programs/VisiOnline/VisiOnline** and log on.
 - Double click on **ZigBee configuration** under the **Cards** tab in the navigation window.
 - Browse to choose a **Card holder** and enter the applicable **No. of days**.
 - At **Type**, choose 'Start discovery in ZigBee'.
 - If applicable, tick the checkbox 'Print receipt'.
 - Click **Make card** and present a card at the encoder.
17. Present the *Discovery card* at the lock.

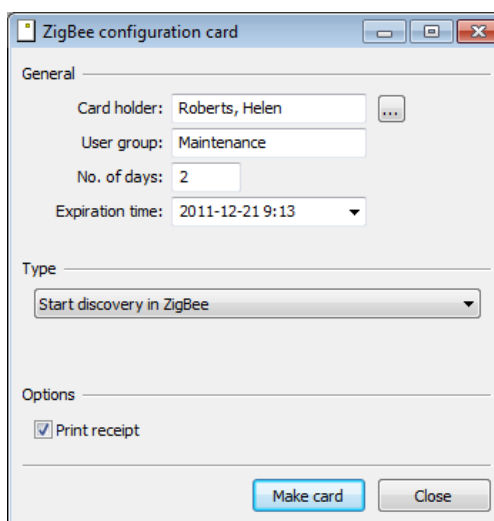

18. In Orion Service, **Configure device** section: click **Get network** under the **Coordinator** tab.

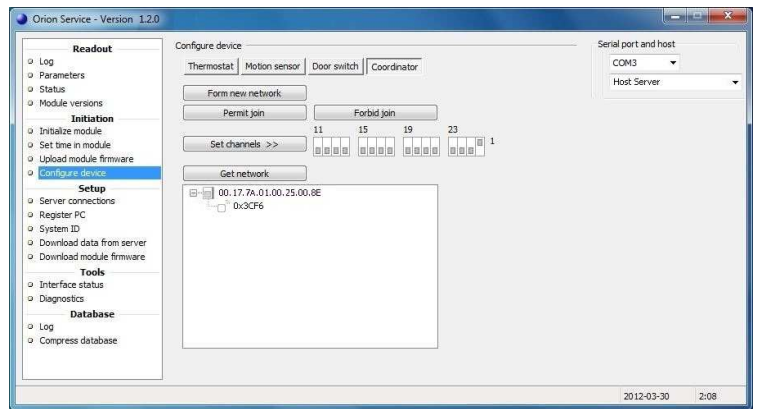

19. Click the plus sign in front of the thermostat controller; the lock will appear in the network tree.
20. Follow the procedure in steps 8-14 and 18-19 to add the motion sensor to the in-room network.

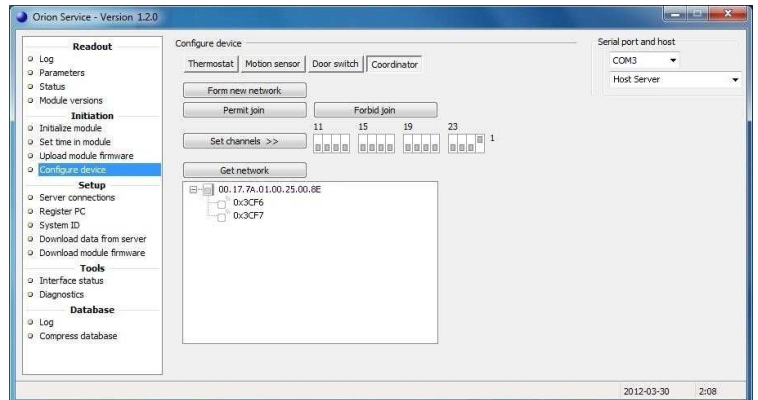

21. Mark the thermostat controller in the Orion Service window and click the **Forbid join** button.
22. Right click on the thermostat controller and choose **Get user description**. Make sure that the description says 'no' at 'Join permitted'.

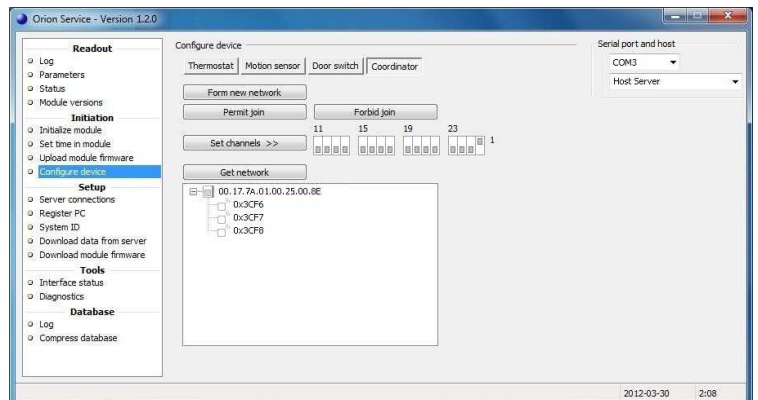

Enabling EMI events

There are two ways to enable that EMI events are sent from the lock:

- by presenting an *Enable EMI events card* at the lock; see section *Enabling EMI events via card*.
- by enabling EMI events from Lock Service; see section *Enabling EMI events via Lock Service*.

For more details about using Lock Service, see *Quick reference guide Service PC*.

Note: Both ways require that the *Online* option has been set in VISIONLINE.

See *Setup manual VingCard VISIONLINE* for information on how to set an option.

Enabling EMI events via card

1. Go to **Start/Programs/VisiOnline/VisiOnline** and log on.
2. Double click on **ZigBee configuration** under the **Cards** tab in the navigation window.
3. At **Card holder**, click the  button.

4. In the **Users <ZigBee configuration card>** dialog, mark the applicable user and click **Select**.

User ID	Last name	First name	User group	E-mail	Cell phone	Created by
hr	Roberts	Helen	Maintenance	helen.roberts@hotel.com	0733-54 21 87	Sym
js	Smith	Josephine	Housekeeping attendants	josephine.smith@hotel.com	0735-12 87 43	n/a
mj	Johnson	Mark	Maintenance	mark.johnson@hotel.com	0736-12 98 43	Sym
Sym	System manager	System manager	Security	system.manager@hotel.com	070-321 76 45	n/a
th	Hanson	Tom	Maintenance	tom.hanson@hotel.com	0735-14 56 78	Sym
ts	Smith	Tim	Maintenance	tim.smith@hotel.com	0736-76 54 32	Sym

5. The **Card holder** and also the **User group** will appear in the **ZigBee configuration card** dialog.
6. Enter the **No. of days**; the **Expiration time** will automatically fill in.
7. At **Type**, choose 'Enable EMI events' in the drop-down-menu.
8. If applicable, tick the checkbox **Print receipt**.
9. Click **Make card**.
10. Present a card at the encoder.
11. Present the *Enable EMI events card* at the lock.

Enabling EMI events via Lock Service

1. Go to **Start/Programs/ Lock Service/Lock Service**.
2. Choose **Configure lock** in the left pane of the Lock Service window.
3. In the drop-down-menu, choose 'Enable EMI events'.
4. Plug the applicable service cable into the lock (may be another service cable than 205 999 005 depending on lock type) and click the **Set** button in Lock Service.

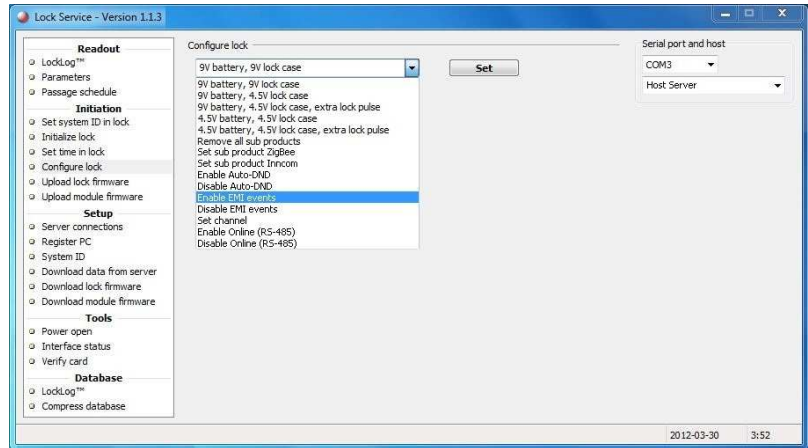

Checking EMI events in Lock Service

1. Choose **Parameters** in the left pane of the Lock Service window.
2. Make sure that 'EMI events' is shown under the **General** tab.

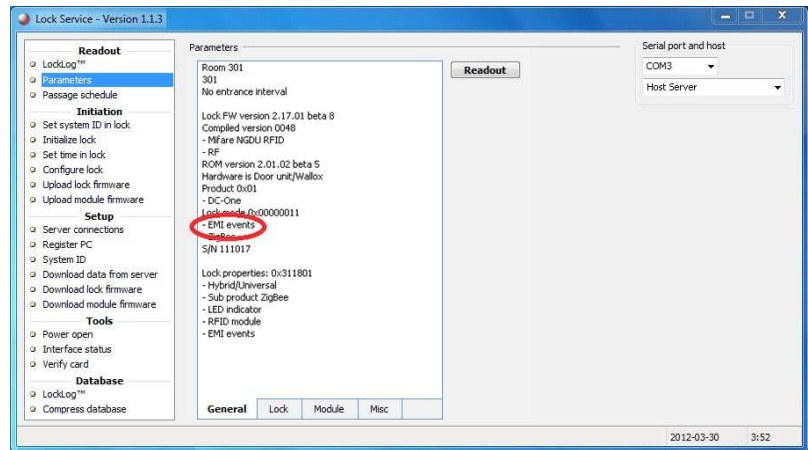

Logging EMI events in Orion Service

If desired:

1. Provoke some EMI events in the lock, e.g. 'Door closed' and 'Motion detected'.
2. Go to **Start/Programs/ Orion Service/Orion Service**.
3. Choose **Log** under the **Readout** section in the left pane; choose the applicable **No. of events**.
4. Plug the service cable into either the wired thermostat or the thermostat controller, depending on configuration.
5. Click the **Readout** button in Orion Service.
6. Ensure that the door and motion events (e.g. 'Door closed' and 'Motion detected') are logged as in the example picture to the right.

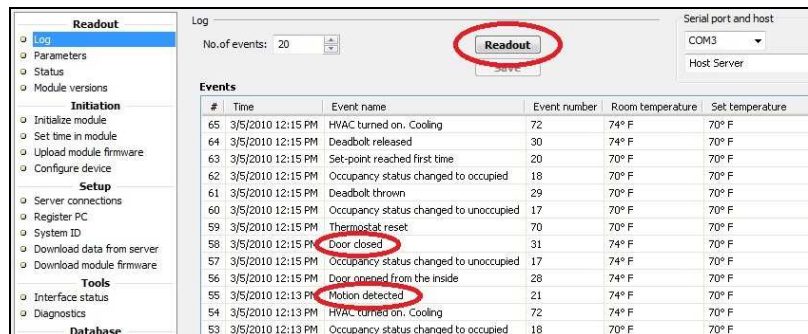

Revision history

Date	Change	By
August 19, 2010	Initial version	KG
November 15, 2010	'Configure device' in Orion Service modified	KG
July 5, 2011	<ul style="list-style-type: none"> • Information about thermostat controller added • Information about service indicators added • Appendix about Orion Service connections added • Appendix about configuration in offline scenarios added 	KG
October 6, 2011	<ul style="list-style-type: none"> • Logotypes changed • Information about commissioning when thermostat controller is used has been added 	KG
October 20, 2011	<ul style="list-style-type: none"> • Section about <i>Recommended wire specification</i> modified due to requirements for UL certification • Picture in section <i>Line to low voltage conversion</i> exchanged due to requirements for UL certification 	KG
February 16, 2012	<ul style="list-style-type: none"> • Added reference to <i>Upgrading an RFID lock for an Orion EMS offline scenario</i> for information about what firmware to use in different configurations • Added information about RF door switch • Modified the section <i>Commissioning the system</i>; use the Thermostat tab also for battery thermostats • Added information to <i>Appendix C: Configuration in offline scenario</i>: <ul style="list-style-type: none"> - configuration pictures - how to enable and log EMI events in locks 	KG
June 5, 2012	<ul style="list-style-type: none"> • Updated to match Orion Service 1.2.0 	KG
July 5, 2012	<ul style="list-style-type: none"> • Info added to chapter <i>1 General</i> about the number of Orion EMS devices that each room number can have 	KG



Asia / Pacific:

E-mail: aspac@vcegroup.com
Phone: +65 67 48 7 227

Europe / Middle East / Africa:

E-mail: emea@vcegroup.com
Phone: +47 69 24 50 00

Latin America:

E-mail: lam@vcegroup.com
Phone: +52 55 36 40 12 14

North America:

E-mail: noram@vcegroup.com
Phone: +1 972 907 2273

VingCard Elsafe – P.O. Box 511 – 1522 Moss – Norway – Phone: +47 69 24 50 00
info@vcegroup.com | www.vingcardelsafe.com
Provider of: VingCard Locks & Systems | Elsafe Safes | Orion EMS | PolarBar Minibars
Specifications may change without notice

FCC Statement

NOTE: This equipment has been tested and found to comply with the limits for a Class B digital device, pursuant to Part 15 of the FCC Rules. These limits are designed to provide reasonable protection against harmful interference in a residential installation. This equipment generates, uses and can radiate radio frequency energy and, if not installed and used in accordance with the instructions, may cause harmful interference to radio communications. However, there is no guarantee that interference will not occur in a particular installation. If this equipment does cause harmful interference to radio or television reception, which can be determined by turning the equipment off and on, the user is encouraged to try to correct the interference by one or more of the following measures:

- Reorient or relocate the receiving antenna.
- Increase the separation between the equipment and receiver.
- Connect the equipment into an outlet on a circuit different from that to which the receiver is connected.
- Consult the dealer or an experienced radio/TV technician for help.

This device complies with part 15 of the FCC Rules. Operation is subject to the following two conditions:

(1) This device may not cause harmful interference, and (2) this device must accept any interference received, including interference that may cause undesired operation

Changes or modifications not expressly approved by the party responsible for compliance could void the user's authority to operate the equipment.