



ZigBee-Ready RF Transceiver Module (IEEE 802.15.4) **CTL3570/1/2/3**

The reproduction of this datasheet is NOT allowed without approval of Computime Limited. All information and data contained in this datasheet are subject to change without notice. This publication supersedes and replaces all information previously supplied. Computime has no responsibility to the consequence of using the information described in this document.

Revision

Rev.	Date (DD-MM-YYYY)	History
1	18-09-2011	First Release
2	04-11-2011	Update Pin assignment



Table of Contents

1. General Description	0
2. Applications	0
3. Features	0
4. Absolute Maximum Ratings.....	1
5. Recommended Operating Conditions	1
6. Electrical Specifications.....	1
7. Typical application block	3
8. Pin Assignment.....	3
9. Pin Description	4
10. Block Diagram.....	11
11. RF Frequency Detail.....	13
12. PCB Layout Recommendations.....	13
13. Mechanical Dimensions	14
14. Modules Differentia	15

1. General Description

The CTL357x RF Transceiver Module is compact surface mounted Module specially designed for Ember ZigBee™ protocol stack for wireless networks, EmberZNet, based on IEEE 802.15.4 standard in the 2.4GHz world-wide ISM band. The complete module is only 32.4 x 25.4 x 4.1 mm. It integrated a 2.4GHz, IEEE 802.15.4-2003 compliant transceiver with a 32-bit network processor (ARM Cortex-M3 Processor). It contains embedded Flash and integrated RAM for program and data storage. It utilizes the non-intrusive SIF module for powerful software debugging and programming of the network processor.

2. Applications



3. Features

- Complete ZigBee-ready module with integrated PCB antenna
- Integrated IEEE 802.15.4 PHY and MAC layer
- Non-intrusive debug interface (SIF)
- SPI interface for communication and controlled by the Host using the EmberZNet Serial Protocol (EZSP)
- Internal RC oscillator for timer
- High performance direct sequence spread spectrum (DSSS) RF transceiver
- 16 channels in the 2.4 GHz ISM band
- On-chip regulator for 2.1-3.6V operation , three sleep low power modes
- 32-bit ARM® Cortex™-M3 processor
- 192KB FLASH ROM and 12KB RAM (EM357 internal) ,8Mb off chip Flash memory (CTL3571&CTL3573)
- +5dBm transmission power (Boost mode up to +8dBm)
- -98dBm excellent reception sensitivity. (Boost mode -101dBm)
- Small footprint: 32.4 x 25.4 x 4.1 mm
- Extremely low Deep Sleep Current.

4. Absolute Maximum Ratings

Parameter	Test Conditions	Min.	Max.	Unit
Regulator input voltage (VDD_PADS)		-0.3	+3.6	V
RF Input Power (for max level for correct packet reception)	RX signal into a lossless balun		+15	dBm
Voltage on any GPIO (PA[7:0], PB[7:0], PC[7:0]), SWCLK, nRESET, VREG_OUT		-0.3	VDD_PADS +0.3	V
Voltage on any GPIO pin (PA4, PA5, PB5, PB6, PB7, PC1), when used as an input to the general purpose ADC with the low voltage range selected		-0.3	2.0	V
Voltage on OSCA, OSCB, NC		-0.3	VDD_PADSA +0.3	V
Storage temperature		-40	+140	°C

5. Recommended Operating Conditions

Parameter	Test Conditions	Min.	Typ.	Max.	Unit
Regulator input voltage (VDD_PADS)		2.7		3.6 ^①	V
Operating temperature range		0		+70 ^②	°C

6. Electrical Specifications

T=25°C, VCC = 3.0V, Fo =2450MHZ, if nothing else stated.

Parameter	Condition / Note	Min	Typ.	Max	Unit
Operating frequency	Programmable in 5MHz steps, 5 MHz steps for IEEE 802.15.4 compliance	2.4		2.5	GHz
Number of channels	For IEEE 802.15.4 compliance		16		
Channel spacing	For IEEE 802.15.4 compliance		5		MHz
Input/output impedance			50		Ohm
Frequency stability				+/-40	ppm
Transmit power	Programmable from firmware	-55		8	dBm

^① Regulator input voltage from 2.1 to 3.6V for module CTL3570 and CTL3572.

^② Operating temperature range from -40 to 85°C for module CTL3570 and CTL3572.

Parameter	Condition / Note	Min	Typ.	Max	Unit
Sensitivity	PER = 1% PER, 20byte packet defined by IEEE 802.15.4 Boost mode		-98		dBm
Adjacent channel rejection +/-5 MHz	IEEE 802.15.4 compliance at -82 dBm		35/35		dB
Adjacent channel rejection +/-10 MHz	IEEE 802.15.4 compliance at -82 dBm		40/40		dB
Co-channel rejection			-6		dB
Supply voltage		2.7		3.6 ^③	V
Current consumption, RX mode	Max RX sensitivity (normal mode)		28		mA
	Max RX sensitivity (boost mode)		30		mA
Current consumption, TX mode			42		mA
Deep sleep current			5.0 ^④		μA
Flash Memory			192 ^⑤		KB
MCU clock frequency			24		MHz

^③ Supply voltage from 2.1 to 3.6V for module CTL3570 and CTL3572.

^④ Deep sleep current less than 8 uA for module CTL3571 and CTL3573.

^⑤ Only CTL3571 and CTL3573 have 8Mb off chip flash memory on the RF module.

7. Typical application block

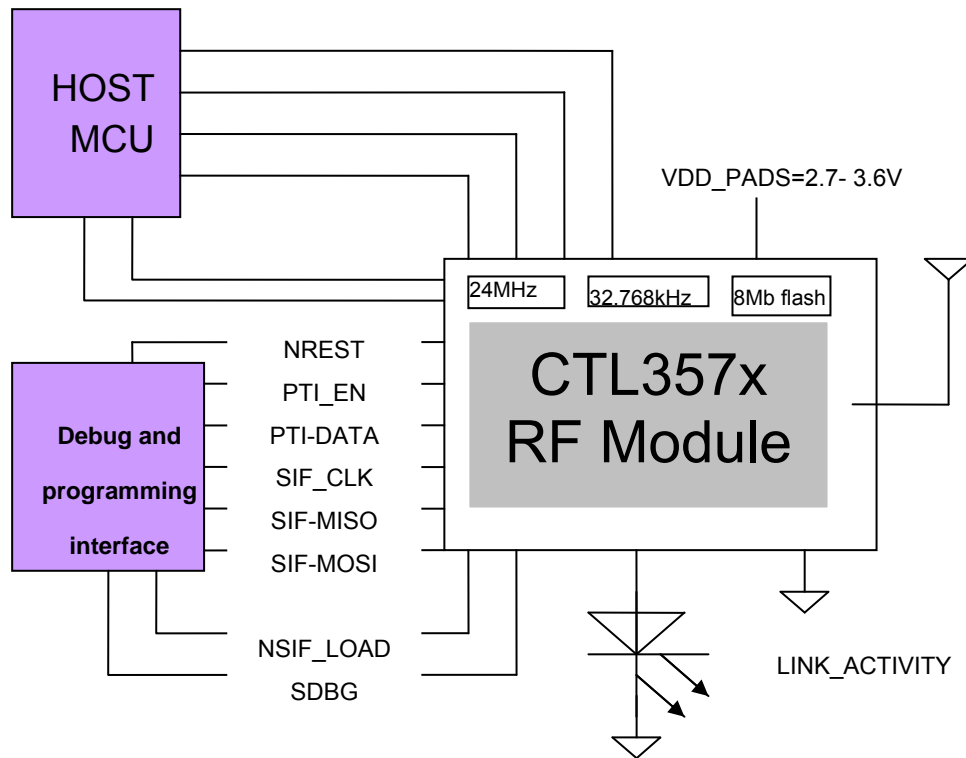

Figure 1: Example of application circuit

8. Pin Assignment

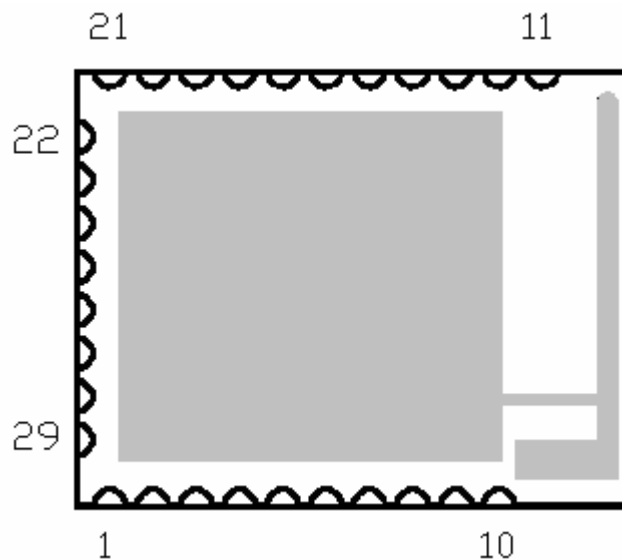

Figure 2: CTL357x pin assignment

9. Pin Description

Pin#	CTL3570	CTL3571	CTL3572	CTL3573	Direction	Description
1	JTCK	JTCK	JTCK	JTCK	I	JTAG clock input from debugger
	SWCLK	SWCLK	SWCLK	SWCLK	I/O	Serial Wire Clock input/output with debugger
2	PC2	PC2	PC2	PC2	I/O	Digital I/O Enable with GPIO_DBGCFG[5]
	JTDO	JTDO	JTDO	JTDO	O	JTAG data out to debugger
	SWO	SWO	SWO	SWO	O	Serial Wire Output asynchronous trace output to
3	PC3	PC3	PC3	PC3	I/O	Digital I/O Enable with GPIO_DBGCFG[5]
	JTDI	JTDI	JTDI	JTDI	I	JTAG data in from debugger
4	PC4	PC4	PC4	PC4	I/O	Digital I/O Either Enable with GPIO_DBGCFG[5]
	JTMS	JTMS	JTMS	JTMS	I	JTAG mode select from debugger
	SWDIO	SWDIO	SWDIO	SWDIO	I/O	Serial Wire bidirectional data to/from debugger
5	PC0	PC0	PC0	PC0	I/O High current	Digital I/O Either Enable with GPIO_DBGCFG[5]
	JRST	JRST	JRST	JRST	I	JTAG reset input from debugger
	IRQD	IRQD	IRQD	IRQD	I	Default external interrupt source D
	TRACEDATA1	TRACEDATA1	TRACEDATA1	TRACEDATA1	O	Synchronous CPU trace data bit 1
6	PB7	PB7	PB7	PB7	I/O High current	Digital I/O
	ADC2	ADC2	ADC2	ADC2	Analog	ADC input 2

ZigBee- Ready RF Transceiver Module CTL3570/1/2/3

	IRQC	IRQC	IRQC	IRQC	I	Default external interrupt source C
	TIM1C2	TIM1C2	TIM1C2	TIM1C2	O	Timer 1 channel 2 output
	TIM1C2	TIM1C2	TIM1C2	TIM1C2	I	Timer 1 channel 2 input
7	PB6	PB6	PB6	PB6	I/O High current	Digital I/O
	ADC1	ADC1	ADC1	ADC1	Analog	ADC input 1
	IRQB	IRQB	IRQB	IRQB	I	External interrupt source B
	TIM1C1	TIM1C1	TIM1C1	TIM1C1	O	Timer 1 channel 1 output
	TIM1C1	TIM1C1	TIM1C1	TIM1C1	I	Timer 1 channel 1 input

Pin#	CTL3570	CTL3571	CTL3572	CTL3573	Direction	Description
8	PA7	PA7	PA7	PA7	I/O High current	Digital I/O Disable REG_EN with GPIO_DBGCFG [4]
	TIM1C4	TIM1C4	TIM1C4	TIM1C4	O	Timer 1 channel 4 output
	TIM1C4	TIM1C4	TIM1C4	TIM1C4	I	Timer 1 channel 4 input
	REG_EN	REG_EN	REG_EN	REG_EN	O	External regulator open drain output
9	PC1	PC1	PC1	PC1	I/O	Digital I/O
	ADC3	ADC3	ADC3	ADC3	Analog	ADC input 3
	SWO	SWO	SWO	SWO	O	Serial Wire Output asynchronous trace output to
	TRACEDATA0	TRACEDATA0	TRACEDATA0	TRACEDATA0	O	Synchronous CPU trace data bit 0
10	GND	GND	GND	GND		

ZigBee- Ready RF Transceiver Module CTL3570/1/2/3

11	PB3	PB3	PB3	PB3	I/O	Digital I/O
	TIM2C3	TIM2C3	TIM2C3	TIM2C3	O	Timer 2 channel 3 output
	TIM2C3	TIM2C3	TIM2C3	TIM2C3	I	Timer 2 channel 3 input
	SC1nCTS	SC1nCTS	SC1nCTS	SC1nCTS	I	UART CTS handshake of Serial Controller 1
	SC1SCLK	SC1SCLK	SC1SCLK	SC1SCLK	O	SPI master clock of serial Controller 1
	SC1SCLK	SC1SCLK	SC1SCLK	SC1SCLK	I	SPI slave clock of serial Controller 1
12	GND	GND	GND	GND		
13	PC6	PC6			I/O	Digital I/O
			OSC32B	OSC32B	I/O	32.768KHz crystal oscillator
	NTX_ACTIVE	NTX_ACTIVE			O	Inverted TX_ACTIVE signal
14	PC7	PC7			I/O	Digital I/O
			OSC32A	OSC32A	I/O	32.768KHz crystal oscillator
	OSC32_EXT	OSC32_EXT			I	Digital 32.768KHz clock input source
15	PC5	PC5	PC5	PC5	I/O	Digital I/O
16	VDD_PADS	VDD_PADS	VDD_PADS	VDD_PADS	Power	Pads supply(2.1-3.6V)
17	nRESET	nRESET	nRESET	nRESET	I	Active low chip reset(internal pull-up)

Pin#	CTL3570	CTL3571	CTL3572	CTL3573	Direction	Description
18	PA0	PA0	PA0	PA0	I/O	Digital I/O

ZigBee- Ready RF Transceiver Module CTL3570/1/2/3

	TIM2C1	TIM2C1	TIM2C1	TIM2C1	O	Timer 2 channel 1 output
	TIM2C1	TIM2C1	TIM2C1	TIM2C1	I	Timer 2 channel 1 input
	SC2MOSI	SC2MOSI	SC2MOSI	SC2MOSI	O	SPI master data out of serial controller 2
	SC2MOSI	SC2MOSI	SC2MOSI	SC2MOSI	I	SPI slave data in of serial controller 2
		SI		SI	I	Serial data in for 8Mb flash®
19	PA1	PA1	PA1	PA1	I/O	Digital I/O
	TIM2C3	TIM2C3	TIM2C3	TIM2C3	O	Timer 2 channel 3 output
	TIM2C3	TIM2C3	TIM2C3	TIM2C3	I	Timer 2 channel 3 input
	SC2SDA	SC2SDA	SC2SDA	SC2SDA	I/O	TWI data of serial controller 2
	SC2MISO	SC2MISO	SC2MISO	SC2MISO	O	SPI slave data out of serial controller 2
	SC2MISO	SC2MISO	SC2MISO	SC2MISO	I	SPI master data in of serial controller 2
		SO		SO	O	Serial data out of 8Mb flash
20	PA2	PA2	PA2	PA2	I/O	Digital I/O
	TIM2C4	TIM2C4	TIM2C4	TIM2C4	O	Timer 2 channel 4 output
	TIM2C4	TIM2C4	TIM2C4	TIM2C4	I	Timer 2 channel 4 input
	SC2SCL	SC2SCL	SC2SCL	SC2SCL	I/O	TWI clock of serial controller 2
	SC2SCLK	SC2SCLK	SC2SCLK	SC2SCLK	O	SPI master clock of serial controller 2

® The SI,SO,SCK and CE# on the module pin18,19,20 and 23 are connected to the off chip 8Mbit SPI Serial Flash(SST25VF080B).Details information about the flash memory ,refers to its datasheet. It applies to the module CTL3571 and CTL3573.

ZigBee- Ready RF Transceiver Module CTL3570/1/2/3

	SC2SCLK	SC2SCLK	SC2SCLK	SC2SCLK	I	SPI slave clock of serial controller 2
		SCK		SCK	I	Clock in for 8Mb flash
21	PA6	PA6	PA6	PA6	I/O High current	Digital I/O
	TIM1C3	TIM1C3	TIM1C3	TIM1C3	O	Timer 1 channel 3 output
	TIM1C3	TIM1C3	TIM1C3	TIM1C3	I	Timer 1 channel 3 input
22	PB4	PB4	PB4	PB4	I/O	Digital I/O
	TIM2C4	TIM2C4	TIM2C4	TIM2C4	O	Timer 2 channel 4 output
	TIM2C4	TIM2C4	TIM2C4	TIM2C4	i	Timer 2 channel 4 input
	SC1nRTS	SC1nRTS	SC1nRTS	SC1nRTS	O	UART RTS handshake of serial controller 1
	SC1nSSEL	SC1nSSEL	SC1nSSEL	SC1nSSEL	I	SPI slave select of serial controller 1

Pin#	CTL3570	CTL3571	CTL3572	CTL3573	Direction	Description
23	PA3	PA3	PA3	PA3	I/O	Digital I/O
	SC2Nssel	SC2Nssel	SC2Nssel	SC2Nssel	I	SPI slave select of serial controller 2
	TRACECLK	TRACECLK	TRACECLK	TRACECLK	O	Synchronous CPU trace clock
	TIM2C2	TIM2C2	TIM2C2	TIM2C2	O	Timer 2 channel 2 output
	TIM2C2	TIM2C2	TIM2C2	TIM2C2	I	Timer 2 channel 2 input
			CE#		CE#	I
24	PA4	PA4	PA4	PA4	I/O	Digital I/O

ZigBee- Ready RF Transceiver Module CTL3570/1/2/3

	ADC4	ADC4	ADC4	ADC4	Analog	ADC input 4
	PTI_EN	PTI_EN	PTI_EN	PTI_EN	O	Frame signal of packet trace interface
	TRACEDATA2	TRACEDATA2	TRACEDATA2	TRACEDATA2	O	Synchronous CPU trace data bit 2
25	PA5	PA5	PA5	PA5	I/O	Digital I/O
	ADC5	ADC5	ADC5	ADC5	Analog	ADC input 5
	PTI_DATA	PTI_DATA	PTI_DATA	PTI_DATA	O	Data signal of packet trace interface
	NBOOTMODE	NBOOTMODE	NBOOTMODE	NBOOTMODE	I	Embedded serial bootloader activation out of reset
	TRACEDATA3	TRACEDATA3	TRACEDATA3	TRACEDATA3	O	Synchronous CPU trace data bit 3
26	PB1	PB1	PB1	PB1	I/O	Digital I/O
	SC1MISO	SC1MISO	SC1MISO	SC1MISO	O	SPI slave data out of serial controller 1
	SC1MOSI	SC1MOSI	SC1MOSI	SC1MOSI	O	SPI master data out of serial controller 1
	SC1SDA	SC1SDA	SC1SDA	SC1SDA	I/O	I2C data of serial controller 1
	SC1TXD	SC1TXD	SC1TXD	SC1TXD	O	UART transmit data of serial controller 1
	TIM2C1	TIM2C1	TIM2C1	TIM2C1	O	Timer 2 channel 1 output
	TIM2C1	TIM2C1	TIM2C1	TIM2C1	I	Timer 2 channel 1 input

Pin#	CTL3570	CTL3571	CTL3572	CTL3573	Direction	Description
27	PB2	PB2	PB2	PB2	I/O	Digital I/O

ZigBee- Ready RF Transceiver Module CTL3570/1/2/3

	SC1MISO	SC1MISO	SC1MISO	SC1MISO	I	SPI master data in of serial controller 1
	SC1MOSI	SC1MOSI	SC1MOSI	SC1MOSI	I	SPI slave data in of serial controller 1
	SC1SCL	SC1SCL	SC1SCL	SC1SCL	I/O	TWI clock of serial controller 1
	SC1RXD	SC1RXD	SC1RXD	SC1RXD	I	UART receive data of serial controller 1
	TIM2C2	TIM2C2	TIM2C2	TIM2C2	O	Timer 2 channel 2 output
	TIM2C2	TIM2C2	TIM2C2	TIM2C2	I	Timer 2 channel 2 input
28	PB5	PB5	PB5	PB5	I/O	Digital I/O
	ADC0	ADC0	ADC0	ADC0	Analog	ADC input 0
	TIM2CLK	TIM2CLK	TIM2CLK	TIM2CLK	I	Timer 2 external clock input
	TIM1CLK	TIM1CLK	TIM1CLK	TIM1CLK	I	Timer 1 external clock mask input
29	PB0	PB0	PB0	PB0	I/O	Digital I/O
	VREF	VREF	VREF	VREF	Analog O	ADC reference output
	VREF	VREF	VREF	VREF	Analog I	ADC reference input
	IRQA	IRQA	IRQA	IRQA	I	External interrupt source A
	TRACECLK	TRACECLK	TRACECLK	TRACECLK	O	Synchronous CPU trace clock
	TIM1CLK	TIM1CLK	TIM1CLK	TIM1CLK	I	Timer 1 external clock input
	TIM2MSK	TIM2MSK	TIM2MSK	TIM2MSK	I	Timer 2 external clock mask input

10. Block Diagram

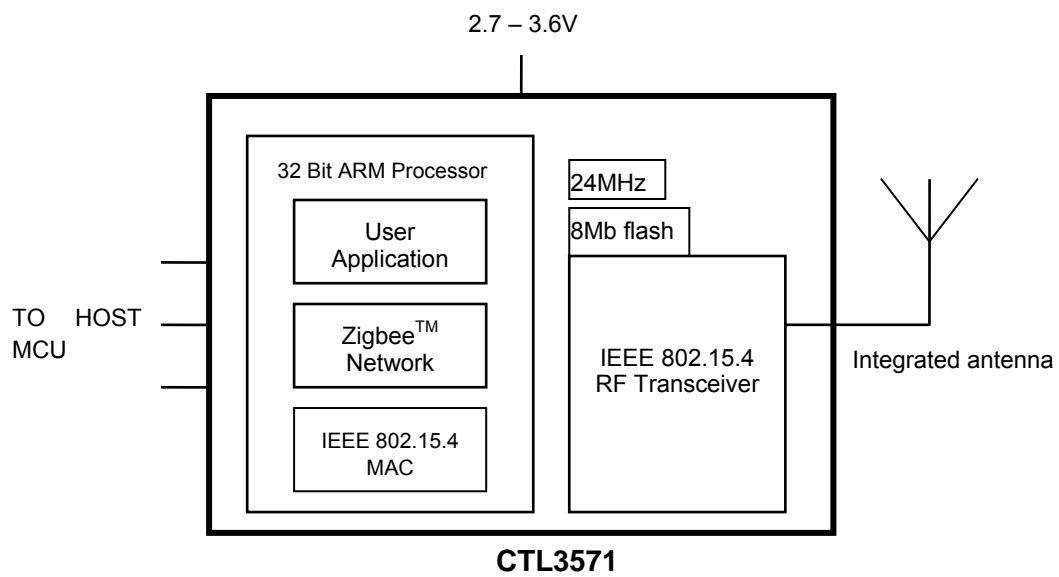
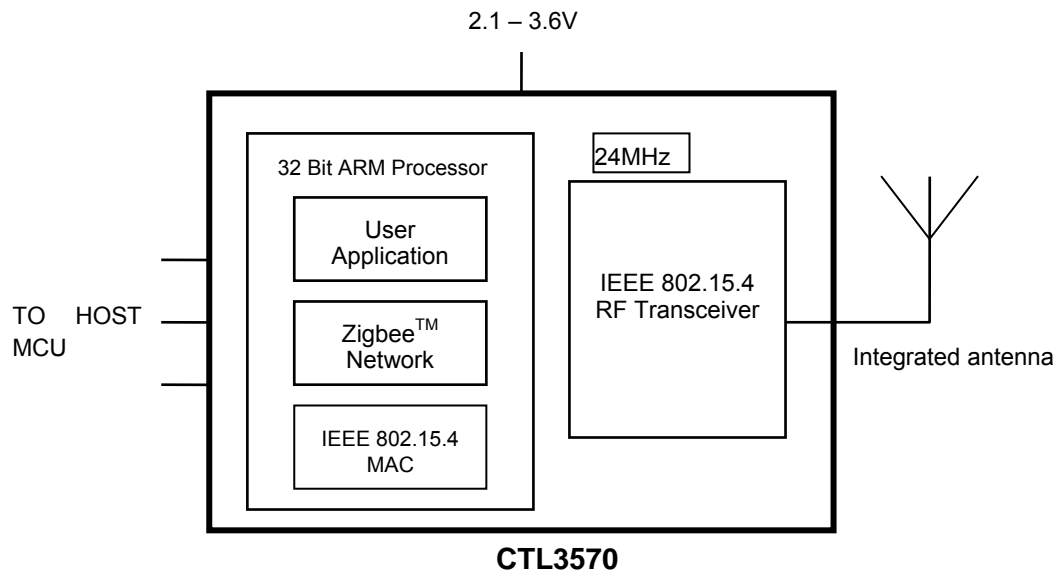

ZigBee- Ready RF Transceiver Module CTL3570/1/2/3

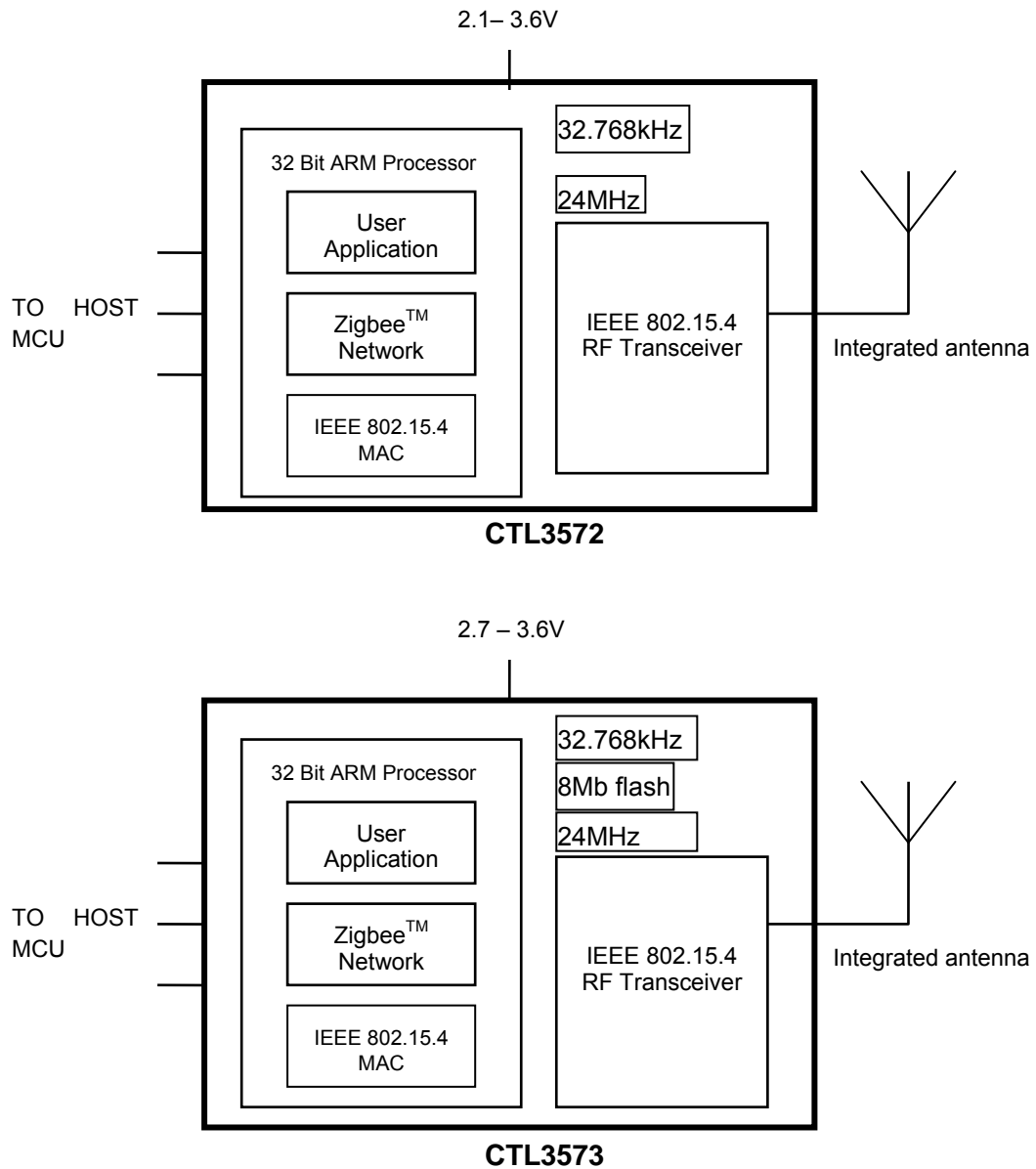

Figure 3: Block Diagram

11. RF Frequency Detail

The following table shows the RF channels as defined by the IEEE 802.15.4 standard.

RF channel	Frequency
11	2405MHz
12	2410MHz
13	2415MHz
14	2420MHz
15	2425MHz
16	2430MHz
17	2435MHz
18	2440MHz
19	2445MHz
20	2450MHz
21	2455MHz
22	2460MHz
23	2465MHz
24	2470MHz
25	2475MHz
26	2480MHz

12. PCB Layout Recommendations

Please reference Mechanical Dimensions shown in next section for PCB layout.

The area underneath the module should be covered with solder mask in order to prevent short circuit on the test pads on the back side of the module. A solid ground plane under the module is preferred.

As the module integrated with onboard PCB trace antenna, the mounting position of the module will have great impact on the RF performance. There should not be any trace, ground plane or metal part underneath or nearby the area of the onboard PCB trace antenna. The figure below shows an example how the module positioned on the mother PCB.

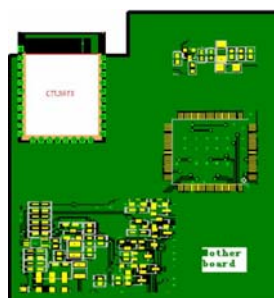
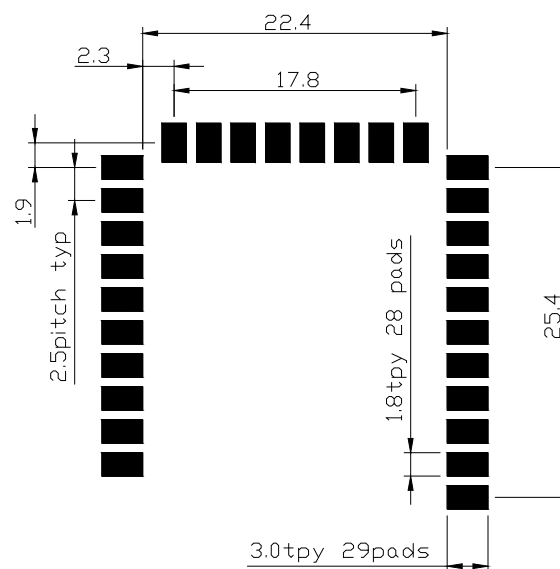
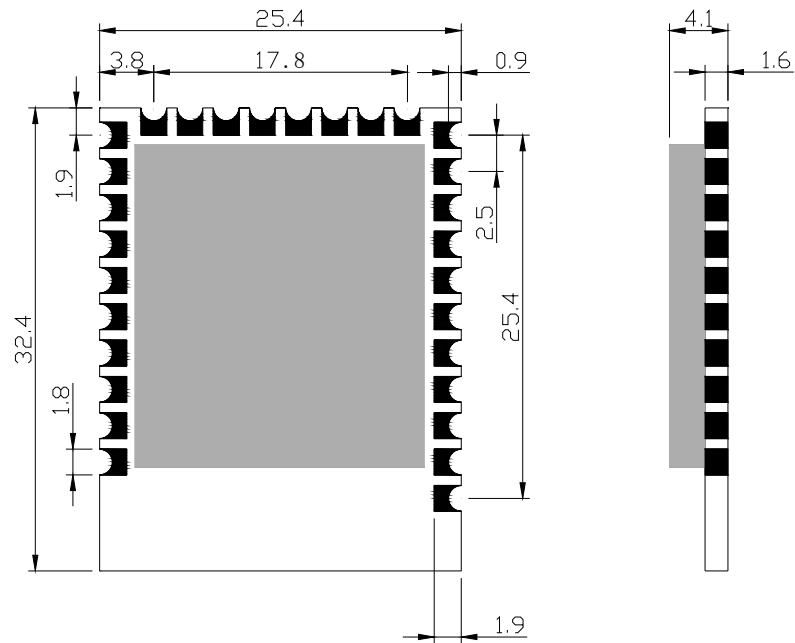

Figure 4: A recommended placement of the module on a main PCB

13. Mechanical Dimensions

Figure 5: Mechanical Dimensions of CTL357x



Recommended PCB footprint

14. Modules Differentia

Computime Model No.	32kHz Crystal	8Mbit Flash Memory
CTL3570	N	N
CTL3571	N	Y
CTL3572	Y	N
CTL3573	Y	Y

FCC STATEMENT

Part 15.19

1. This device complies with Part 15 of the FCC Rules. Operation is subject to the following two conditions:

(1) This device may not cause harmful interference.

(2) This device must accept any interference received, including interference that may cause undesired operation.

Part 15.21

2. Changes or modifications not expressly approved by the party responsible for compliance could void the user's authority to operate the equipment.

Part 15.105

NOTE: This equipment has been tested and found to comply with the limits for a Class B digital device, pursuant to Part 15 of the FCC Rules. These limits are designed to provide reasonable protection against harmful interference in a residential installation.

This equipment generates uses and can radiate radio frequency energy and, if not installed and used in accordance with the instructions, may cause harmful interference to radio communications. However, there is no guarantee that interference will not occur in a particular installation. If this equipment does cause harmful interference to radio or television reception, which can be determined by turning the equipment off and on, the user is encouraged to try to correct the interference by one or more of the following measures:

Reorient or relocate the receiving antenna.

Increase the separation between the equipment and receiver.

Connect the equipment into an outlet on a circuit different from that to which the receiver is connected.

Consult the dealer or an experienced radio/TV technician for help.

Part 2.1091

For purposes of this section, a mobile device is defined as a transmitting device designed to be used in other than fixed locations and to generally be used in such a way that a separation distance of at least 20 centimeters is normally maintained between the transmitter's radiating structure(s) and the body of the user or nearby persons. In this context, the term "fixed location" means that the device is physically secured at one location and is not able to be easily moved to another location. Transmitting devices designed to be used by consumers or workers that can be easily re-located, such as wireless devices associated with a personal computer, are considered to be mobile devices if they meet the 20 centimeter separation requirement.

If the FCC identification number is not visible when the module is installed inside another device, then the outside of the device into which the module is installed must also display a label referring to the enclosed module. This exterior label can use wording such as the following: "Contains Transmitter Module FCC ID: DI2-CTL3573"

Canada information:

This device complies with Industry Canada licence-exempt RSS standard(s). Operation is subject to the following two conditions:

(1) this device may not cause interference, and (2) this device must accept any interference, including interference that may cause undesired operation of the device.

Le présent appareil est conforme aux CNR d'Industrie Canada applicables aux appareils radio exempts de licence. L'exploitation est autorisée aux deux conditions suivantes : (1) l'appareil ne doit pas produire de brouillage, et (2) l'utilisateur de l'appareil doit accepter tout brouillage radioélectrique subi, même si le brouillage est susceptible d'en compromettre le fonctionnement.

If the IC identification number is not visible when the module is installed inside another device, then the outside of the device into which the module is installed must also display a label referring to the enclosed module. This exterior label can use wording such as the following: "Contains Transmitter Module IC: 1700D-CTL3573

IC RF warning statement

This equipment complies with IC radiation exposure limits set forth for an uncontrolled environment. This equipment should be installed and operated with minimum distance 20cm between the radiator & your body.

Under Industry Canada regulations, this radio transmitter may only operate using an antenna of a type and maximum (or lesser) gain approved for the transmitter by Industry Canada. To reduce potential radio interference to other users, the antenna type and its gain should be so chosen that the equivalent isotropically radiated power (e.i.r.p.) is not more than that necessary for successful communication.



Contact information

COMPUTIME CORPORATE HQ

17/F, Great Eagle Centre,
23 Harbour Road, Wanchai,
Tel: +852.2260.0300
Fax: +852.2790.3996
e-mail: hq@computime.com

COMPUTIME NORTH AMERICA HQ,

4700 Duke Dr.
Suite 200
Mason OH 45040
USA
Tel: +1(513).398.2579
Fax: +1(513).754.8955
e-mail: na@computime.com

CINCINNATI WIRELESS SOLUTIONS LTD

4700 Duke Dr.
Suite 200
Mason OH 45040
USA
Tel: +1(513).754.8935
Fax: +1(513).754.8955
e-mail: ctws@computime.com

COMPUTIME JAPAN

3-18-9 Roppongi Minatoku,
Tokyo 106-0032,
Japan
Tel: (03).3583.8411
Fax: (03).3583.3799
e-mail: cj@computime.com

About Computime

Founded in 1974, **Computime** is a global technology, brand and manufacturing company providing innovative automation and control solutions to customers in commercial, industrial and consumer markets.

The Company provides technologies and products that save energy and make people's lives more productive and comfortable.