



Fireplace new platform product specification

CONFIDENTIAL

The reproduction of this datasheet is NOT allowed without approval of Computime Limited. All information and data contained in this datasheet are subject to change without notice. This publication supersedes and replaces all information previously supplied. Computime has no responsibility to the consequence of using the information described in this document.

Fireplace new platform product specification

Scope: This document establishes the performance, design, test, and acceptance requirements for the fireplace new platform controller.

Revision History

Rev.	Date (DD-MM-YYYY)	History / Change	Prepared By
0.1	20 February 2014	First draft	WY Qu
0.2	09 April 2014	Second draft	WY Qu
0.3	15 April 2014	Third draft <ul style="list-style-type: none"> - Add more description on Backlight(3.1.16) - Define model option(3.1.3) - Clear low battery operation(3.1.11) - Define Receiver operation (3.2.2) - Modified pulse define(5.1.4) - Define software flowchart 	KL Tsang
1.0	16 April 2014	Official Rev 1.0 release	KL Tsang
1.1	20 June 2014	<ul style="list-style-type: none"> - At 'Lo' state, all keys can operate and send command - At 'Hi' state, OFF key can operate only.(3.1.15) - Add sensor error operation(3.1.17) - Remain the status(OFF) from OFF to RS(3.2.2) - Change Reset to power on(5.1.3) - Update sensor error operation main loop of transmitter - Add max temperature checking in flowchart 	KL Tsang
1.2		<ul style="list-style-type: none"> - Change Low battery detection operation(3.1.11) - Resume the previous status from OFF to RS(3.2.2) 	KL Tsang
		-	
		-	

Table of Contents

1 General Description	1
2 System requirements.....	2
3 Functional specifications.....	3
4 RF Specifications.....	8
5 RF protocol & commands.....	8
6 Software specifications	10
7 Mechanical specifications.....	14
8 Regulatory specifications.....	14
9 Environmental specifications	14
10 Quality.....	14
11 Design test requirements.....	14
12 Warranty period	14
13 Packaging	14

CONFIDENTIAL

1 General Description

The fireplace controller is able to control the fireplace through the 350MHz wireless control, including the temperature set function, detection and program control, and fan & ignition control function. It includes the remote and receiver.

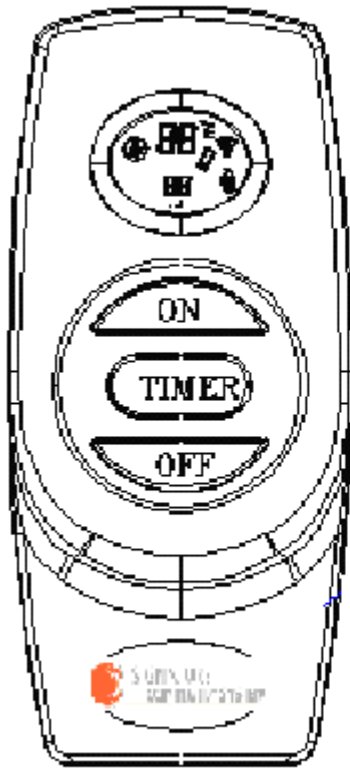

TX

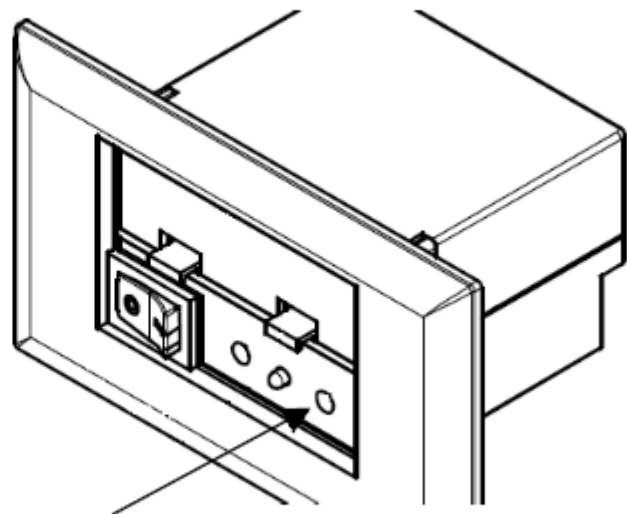

RX

COM

2 System requirements

To develop a RF remote and receiver control that will control the operation of a milli-volt gas valve and Grand mate Stepper motor on the fireplace controller from a transmitter.

2.1. Remote system block diagram:

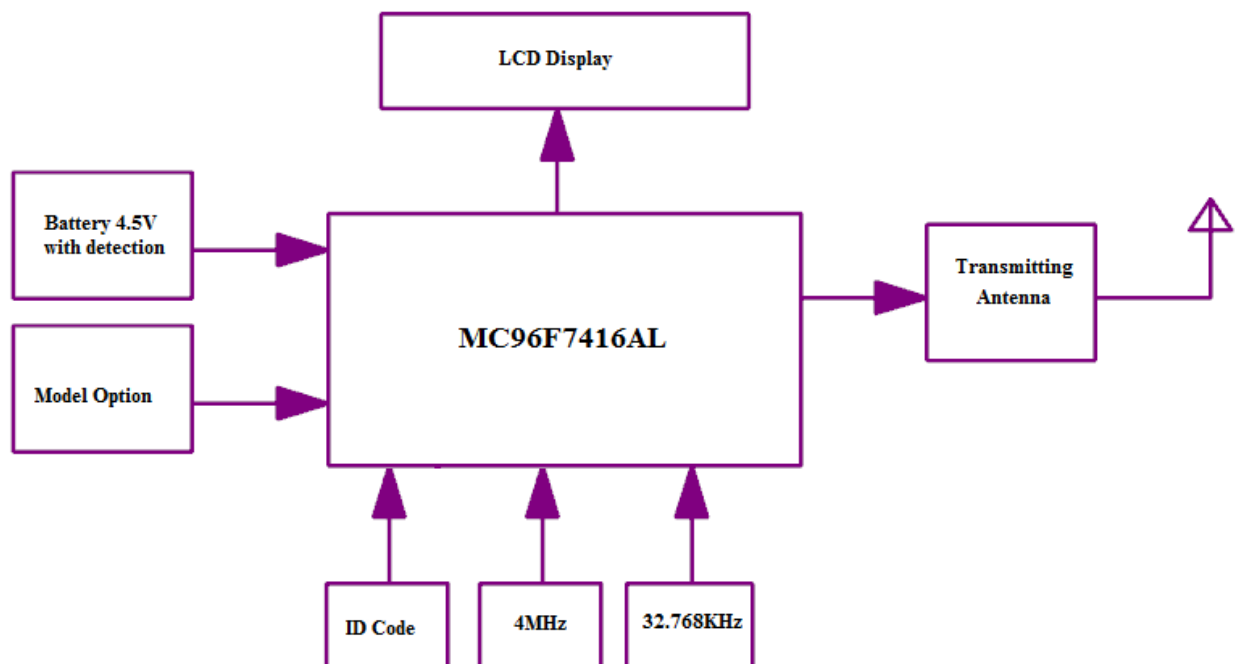

2.2. Receiver system block diagram:

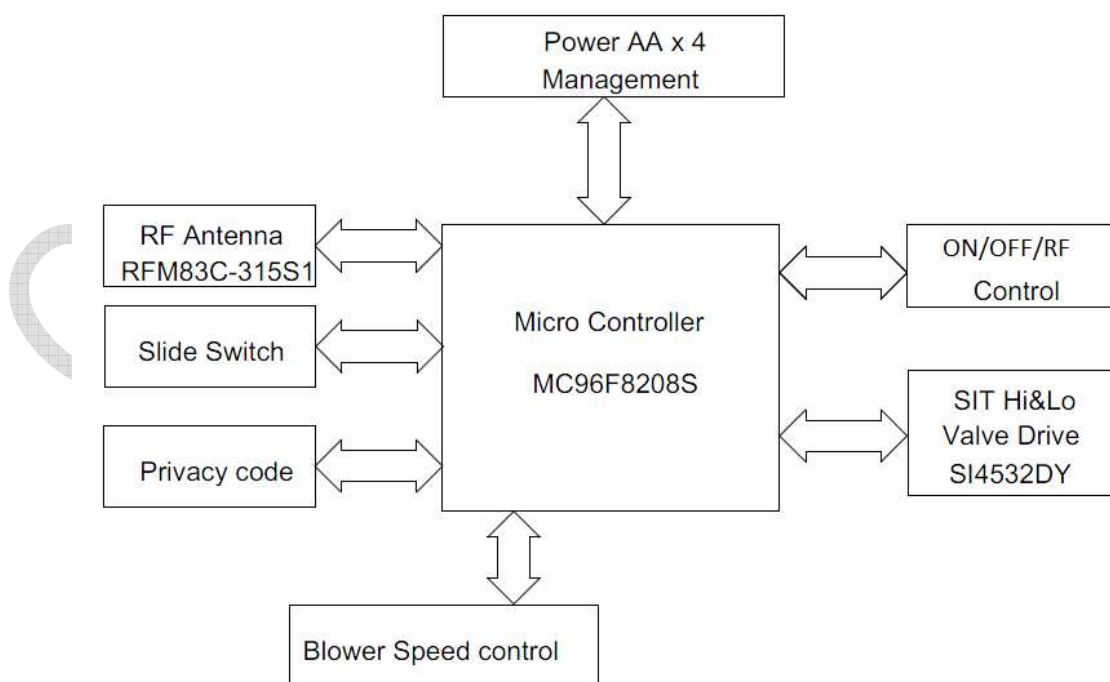

3 Functional description

3.1 Transmitter functions:

LCD display:

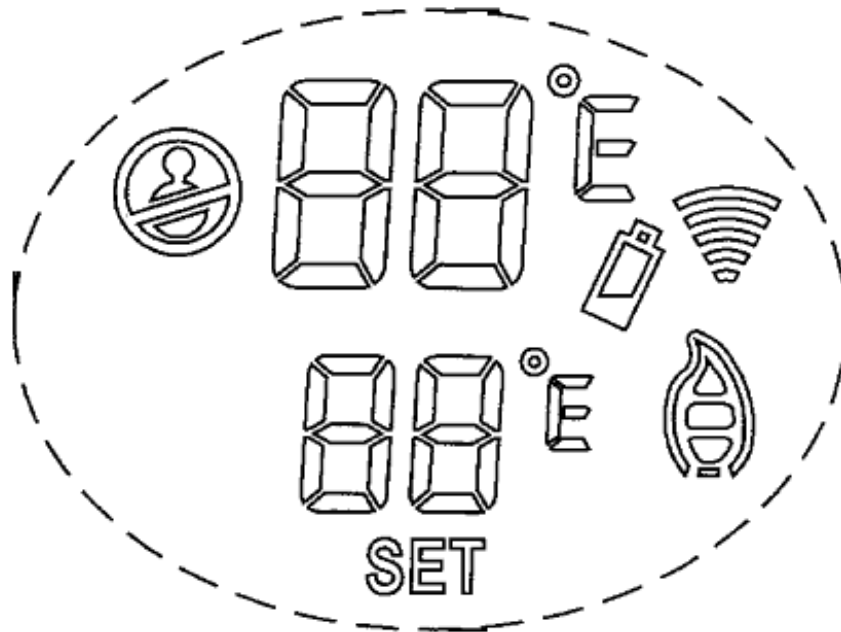

3.1.1 The Remote with LCD to show the temperature set, room temperature, flame height, RF icon, low battery and child lock.

3.1.2 °C and °F degree selection: During system reset, all icons of the LCD display will be visible, after one second, the LCD displays will be initialized and the backlight (R/G/B) will be on simultaneously. The temperature scale is °F by default. Press ON button to select between °C and °F. If no key is pressed for 10 seconds, the remote will exit the setting mode automatically and enter the main screen. The transmitter will send an OFF command after reset.

3.1.3 Model option: Select the models, which include ModelA_Tx1, ModelA_Tx2 and ModelB_Tx1.

Model Selection Pin (Hardware defined)		Model no
Opt 1	Opt 2	
1	1	ModelA_Tx1
1	0	ModelA_Tx2
0	1	ModelB_Tx2

3.1.4 RF Icon: When transmitter has commands being sent, the RF icon will be shown.

Fireplace new platform product specification

3.1.5 Manual Mode: Press the ON button once to turn on the fireplace with max flame height, and then press the OFF button to decrease flame height, the first two pressing with decrease flame height to lower level. The third pressing will be turn fireplace off. (Flame height adjustment only for ModelA_Tx1)

ModelA_Tx2 and ModelB_Tx1 only Flame ON and Flame OFF, not flame height adjustment. Flame icon only showed max flame height and Off.



3.1.6. Ruber key button and buttons function:

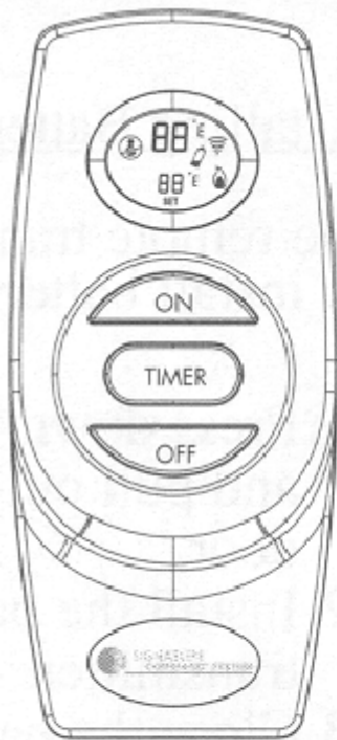

ModelA_Tx2
ModelA_Tx1

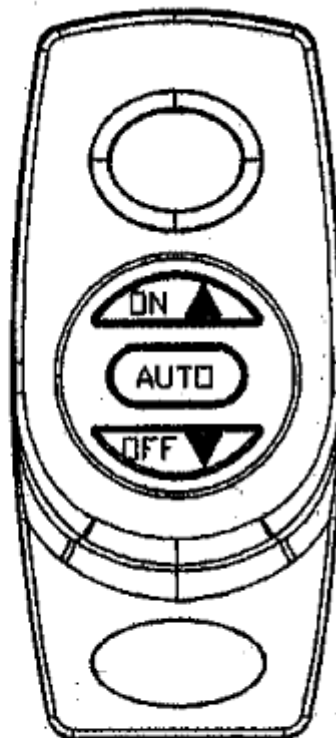

ModelB_Tx1

Fireplace new platform product specification

3.1.7 Auto mode: Press the AUTO button to enter the thermostatic mode. SET icon will be appeared on the lower LCD screen. In thermostatic mode, press ON button or OFF button to set the desired set temperature. Once the setting is completed, the transmitter will be automatically turned on the fireplace when the room temperature is below the set temperature. The transmitter will be turned off when above the set temperature. The temperature range is within 1 degree. There will be a slight delay in the response of the unit (on/off) to a temperature. Room temperature is monitored every 3 minutes. Press the AUTO button to exit the thermostatic mode. The SET icon will be disappeared on the LCD display. The transmitter will be in the manual on/off mode. The AUTO mode only for ModelB_Tx1.

3.1.8 Timer mode: Press the Timer button to start the timer, 90 min as shown in LCD and SET icon below 90 in LCD. 2ND press the Timer button, the timer will be set to 60 min, 3rd press the timer button the timer will be set to 30 min. Three seconds later, the transmitter will be turn on the fireplace.

Once the timer is 0 min, the transmitter will be send off signal and turn off the fireplace.

Press the OFF button to exit the timer mode and the transmitter will be shut off the fireplace.

3.1.9 Room temperature: Show the current room temperature, display temperature range: 40 °F-99 °F (5-37°C), accuracy is +/-1 °C. every 3 minute to check the room temperature.

3.1.10 The temperature setting range are 45 °F-90 °F(7-32°C).

3.1.11 Low battery: When the battery voltage of remote is less than 3.4V, the low battery icon will be shown. The battery will be checked every minute. If the battery voltage of remote is less than 3.2V, the remote will send the flame OFF command to the receiver and turn off the flame.



3.1.12 Child lock - When press and hold the ON and OFF buttons for 3 seconds, the remote will be locked, the LCD will show the child lock icon and current status, and user cannot change any setting when pressing the buttons. It will be unlocked when press and hold the ON and OFF buttons again for 3 seconds.

3.1.13 ID code.

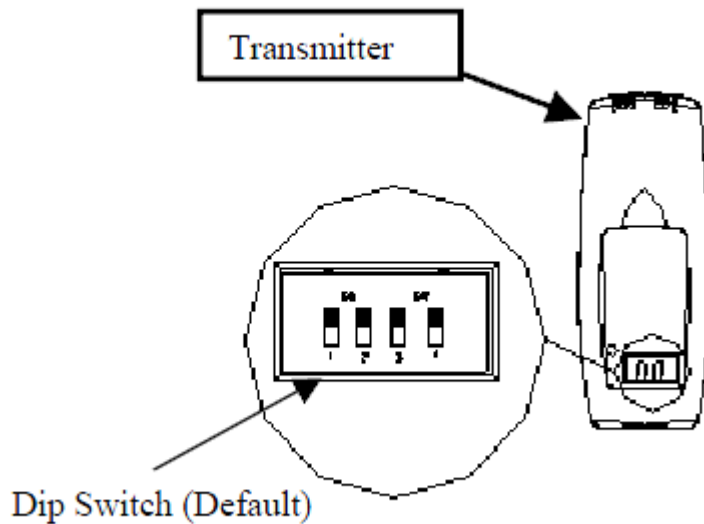

There are 4 bit Dip switch for remote and receiver, the remote ID set must match receiver, If not, the remote will be can't control the receiver.

3.1.14 Reset button: The Reset button in left of ID DIP switch, press the Reset button to reset the remote and initialization, re-select the °F or °C again.

3.1.15 High temperature shut down: if the transmitter measures a room temperature exceeding 99 °F or 37°C, the LCD will display “HI” and the transmitter will turn off the fireplace. The transmitter will function on OFF key only until the room temperature has dropped below 99 °F or 37°C. (for safety issue)

If the transmitter measures a room temperature less than 40 °F or 4°C, the LCD will display “Lo” . The all keys can operate and can be sent the commands to operate the fireplace.

3.1.16 Backlight: The backlight colour will change according to the current temperature range. If the room temperature over the 26°C (78 °F), then the backlight will be Red. If room temperature less than 16°C (61 °F), the backlight will be Green. Backlight will be Blue if the room temperature is between 16-26°C . When any key is pressed the backlight will turn on for 8 seconds and then turn off.

3.1.17 Sensor Error: If the temperature sensor circuit is opened, display “E0”. If the temperature sensor circuit is shorted, display “E1”. Both cases would lock up all keys and shut down all operating processes until reset its power again. Whenever a sensor error is detected, transmitter must turn off the flame. (for safety issue)

3.2. Receiver functional specification:

3.2.1. ID setting: The receiver ID must match with transmitter ID. The 4 position DIP switch will be applied for receiver board.

3.2.2 Slide Switch: The slide switch should be used to perform the manual control or specific functions as defined for each individual receiver.

The fireplace operation should start at remote position. When slide switch starts from ON or OFF position after new battery installed or reset, no operation should perform and system should be in shutdown states. When fireplace starts at remote position, the fireplace will be in flame off state. The fireplace starts the fire control if it receives the flame on command from transmitter.

When slide switch moves from RS to ON position, the fireplace should be turned on at its highest flame height. Six hour shutdown operation should not be performed.

When slide switch moves from ON to RS position, the fireplace should resume the previous state operated at RS position.

When slide switch moves from RS to OFF position, the fireplace should be shut off. Six hour shutdown operation should not be performed.

When slide switch moves from OFF to RS position, the fireplace should resume the previous state operated at RS position.

3.2.3 During power up the receiver, the LED will flash 3 times, and the duration is 500ms on every flash. Then, LED will turn on 5 seconds. After that, LED will turn off.

3.2.4 Connector: A 2pins connectors should be used to provide all external connection for ON/OFF control.

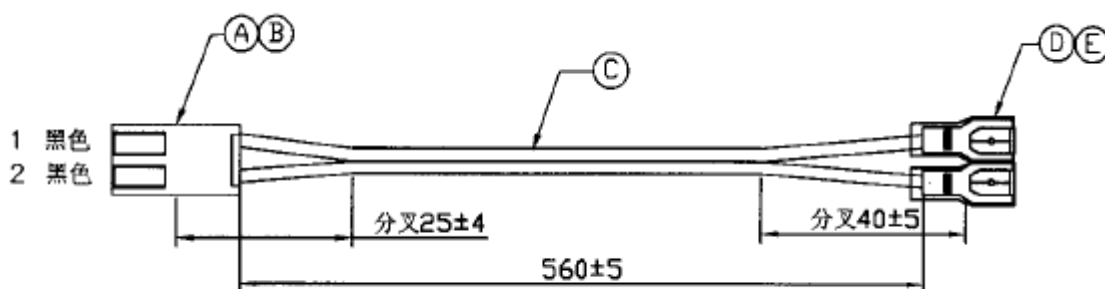

3.2.5 RF module and Antenna: A 350MHz RF module is used for communication with Remote. It must meet the range of more than 30 feet when the receiver assembly on fireplace.

Fireplace new platform product specification

3.2.6 Battery: AA * 4 Alkaline battery for receiver power supply. The four AA battery lifetime should be enough to perform at least four operations ON and OFF in a day for minimum 240 days. The low battery monitoring circuit should indicate the low battery condition at 3.9V. The fireplace should shut down completely and receiver should not accept any command from transmitter once battery drops below 3.9V for four AA batteries, LED will flash every 60 second until battery totally drains out.

3.2.7 LED indication: The receiver should provide the indication when it receives and decodes the commands from transmitter correctly. The on-board LED should be implemented to perform this function.

3.2.8 Six Hour Shutdown: The receiver should be shut down completely six hours later if it does not receive valid command from transmitter. No shutdown is required when slide switch is at ON or OFF position.

3.2.9 A 5Pin programmer port should be used for online programming.

4 RF Specifications

350MHz RF frequency

More than 30 feet RF Range

5 RF protocol & commands

The following protocol defines the wireless control commands for the fireplace. All commands must follow the protocols.

5.1 Code description

5.1.1 Each command consists of 4 start bits, 4 address bits and 8 data bits

5.1.2 The transmitted sequence is as follows:

S0	S1	S2	S3	A3	A2	A1	A0	D7	D6	D5	D4	D3	D2	D1	D0
----	----	----	----	----	----	----	----	----	----	----	----	----	----	----	----

S0 - S3 start bits.

A0 - A3 specified by on-board dip switch. A3: MSB, A0: LSB

D0 - D7 command bits are defined by the following tables:

5.1.3. Commands:

Items	Command	Command, Hex	Function
	1010xxxx00000000	Ax00	Off
	1010xxxx00000001	Ax01	On
	1010xxxx01010000	Ax50	After reset

5.1.4 Pulses define:

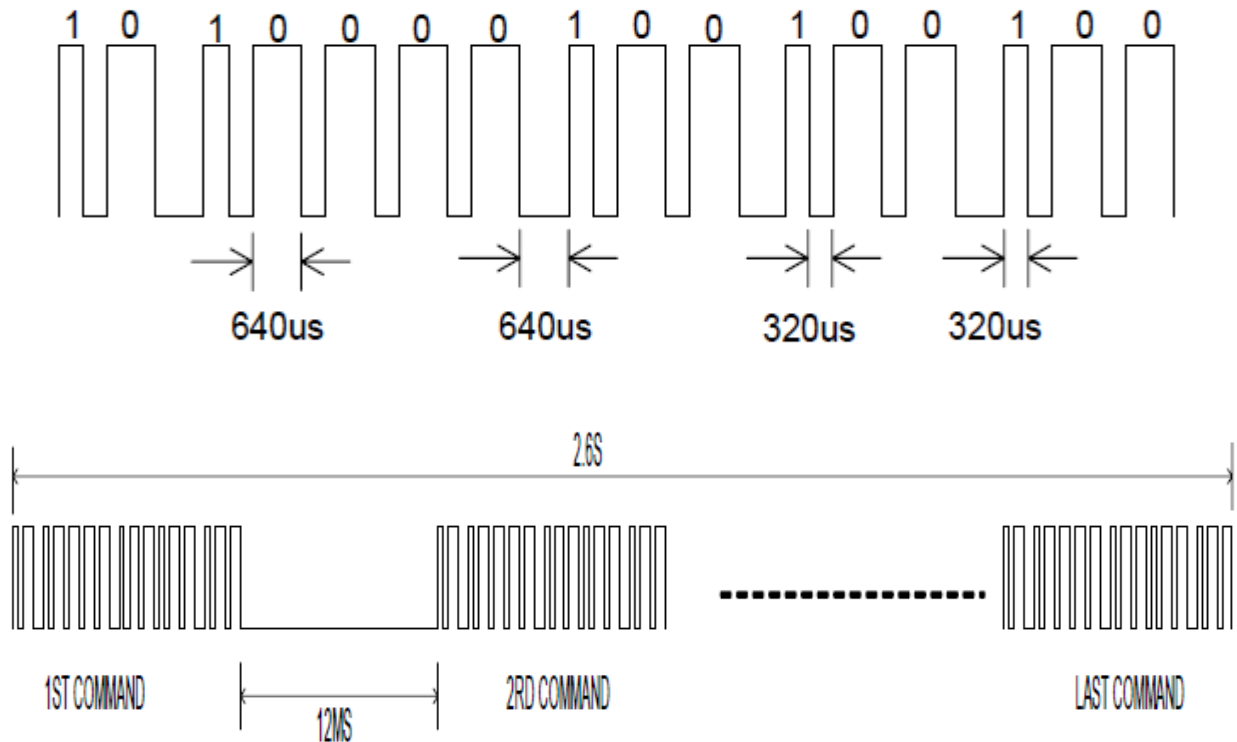

5.1.4.1 Wide pulse is defined as bit '0' and narrow pulse as bit '1'.

5.1.4.2 Wide pulse width is 640us and narrow width as 320us, +/-10%.

5.1.4.3 Duration between two pulses (pulse rising edge to previous falling edge): for next wide pulse: 640us and for next narrow pulse: 320us.

5.1.4.4 Duration between each 16 bit command: 12ms +/-10%

5.1.4.5 Total Number of Command: 2.6s, +/-10%

5.1.4.6 The start bits for each 16 bit command are defined as '1010'.

6 Software specification

6.1 Program flowchart of Start(Reset/power up)

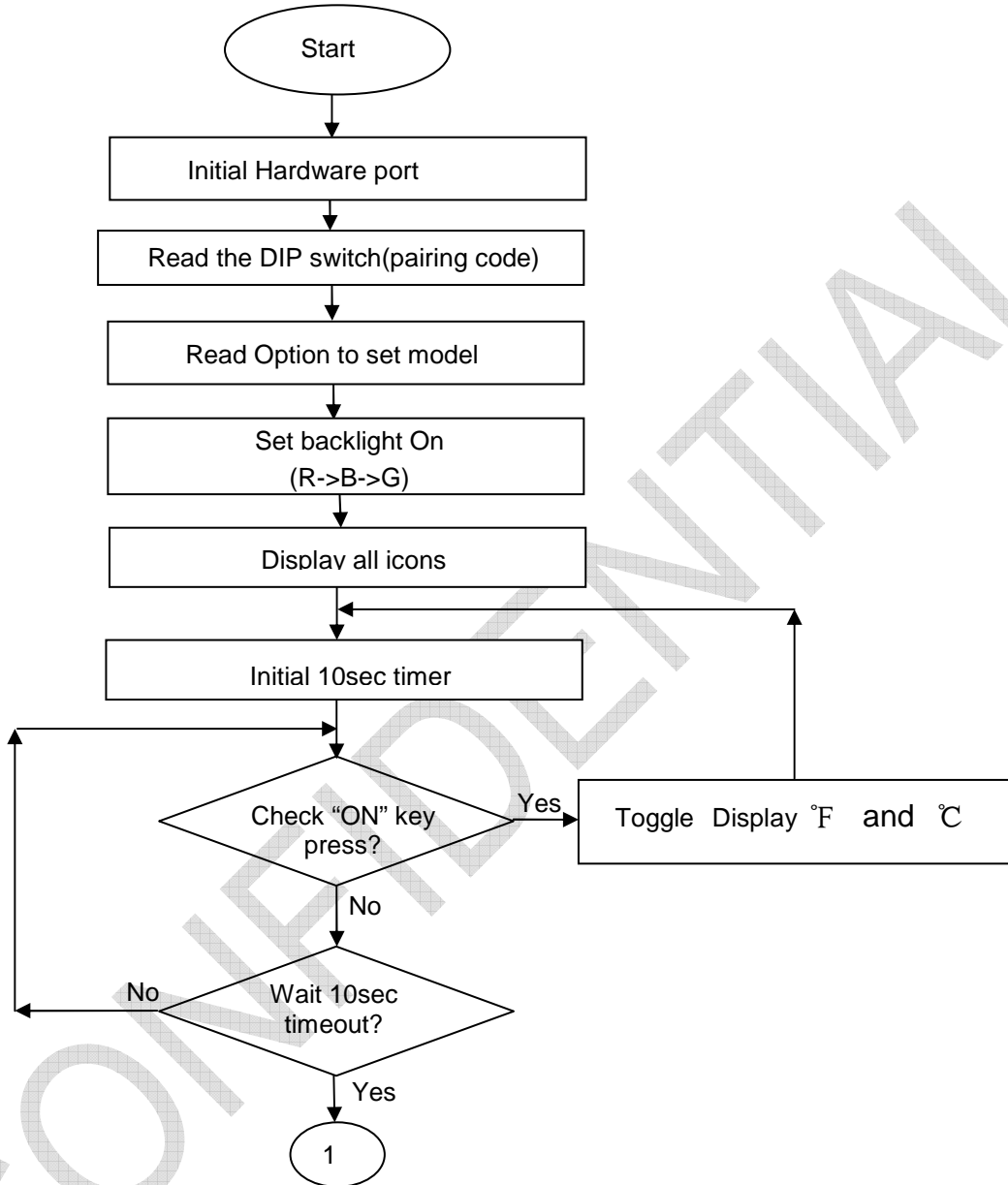

Fireplace new platform product specification

6.2 Main Loop of transmitter

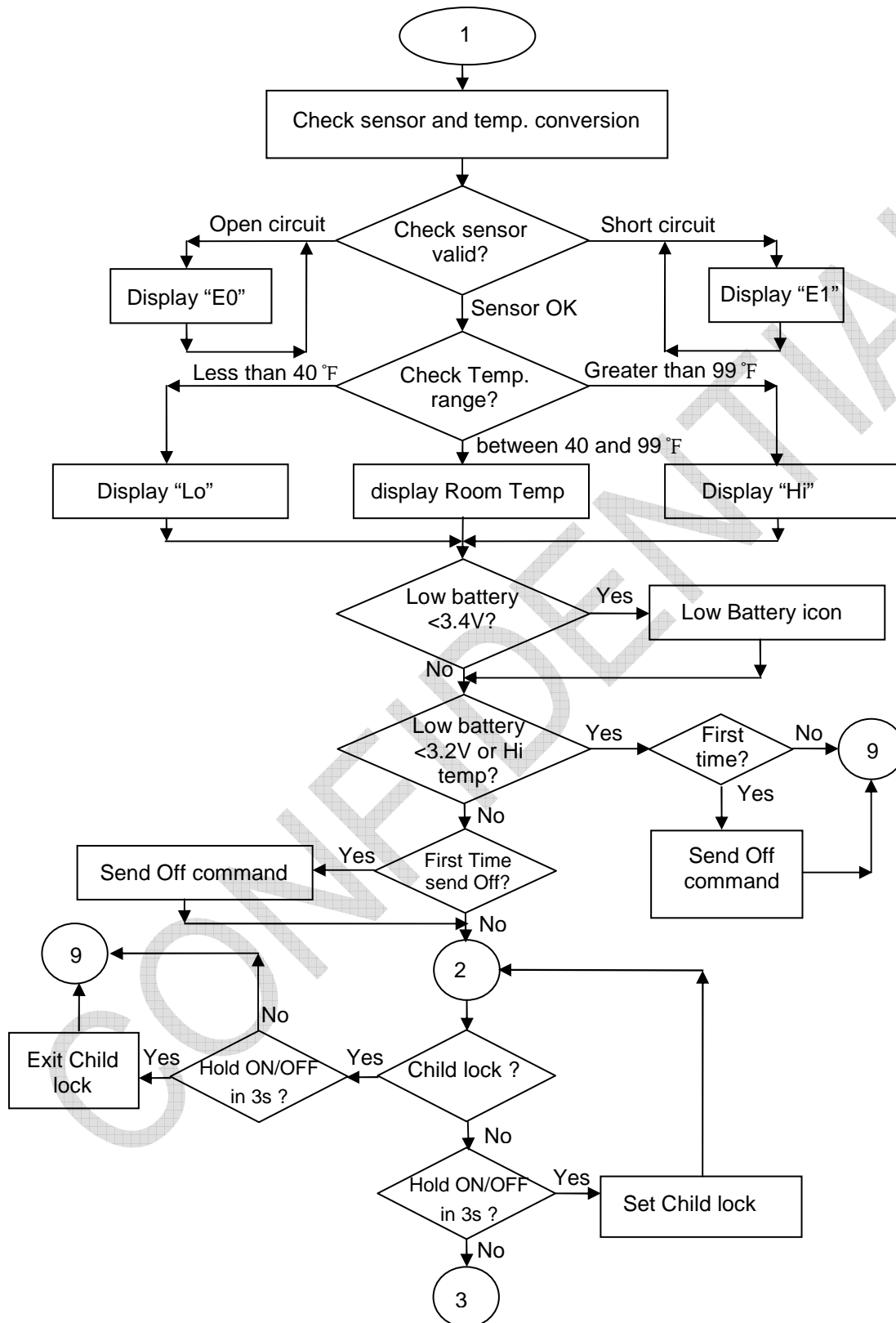

Fireplace new platform product specification

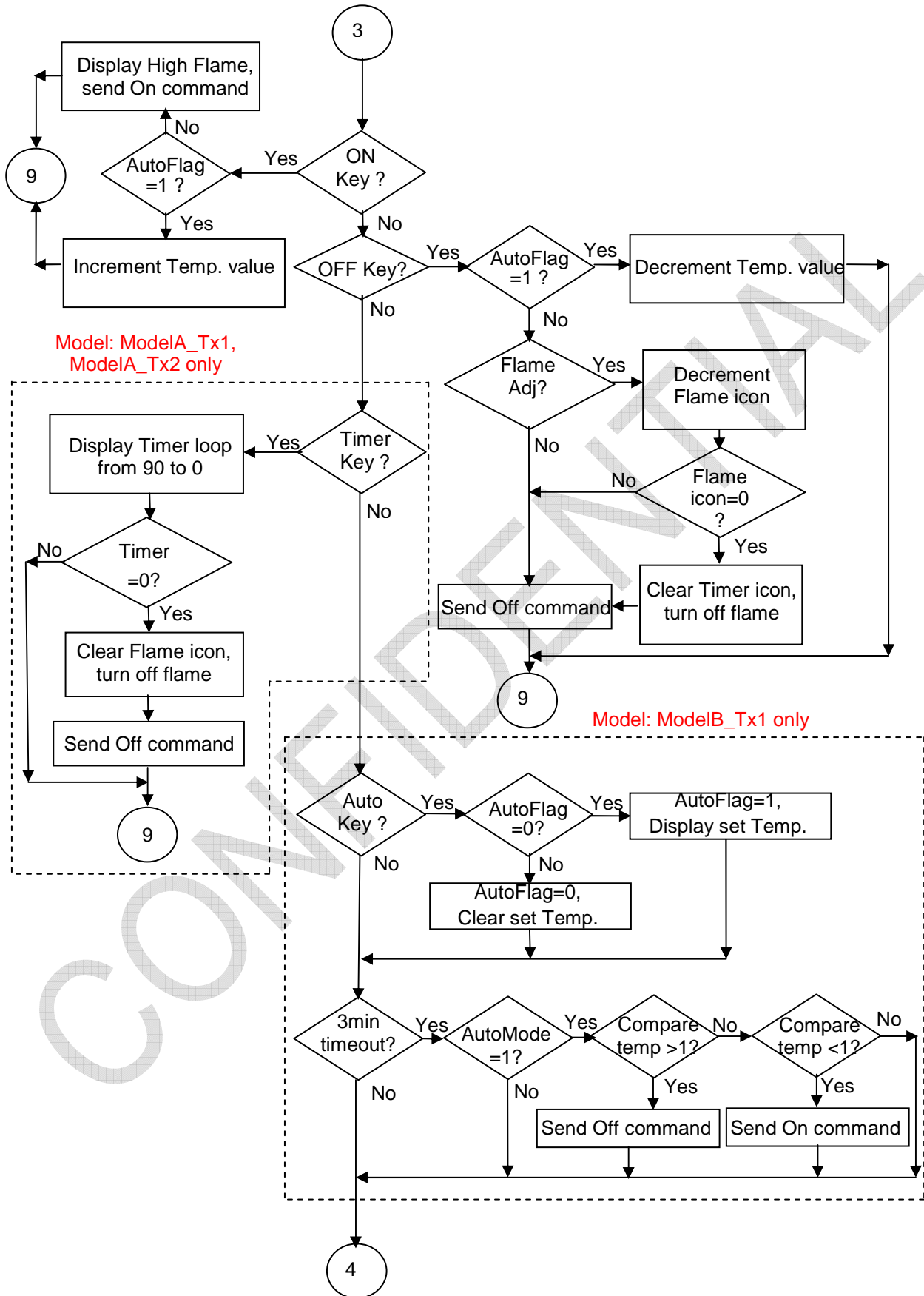

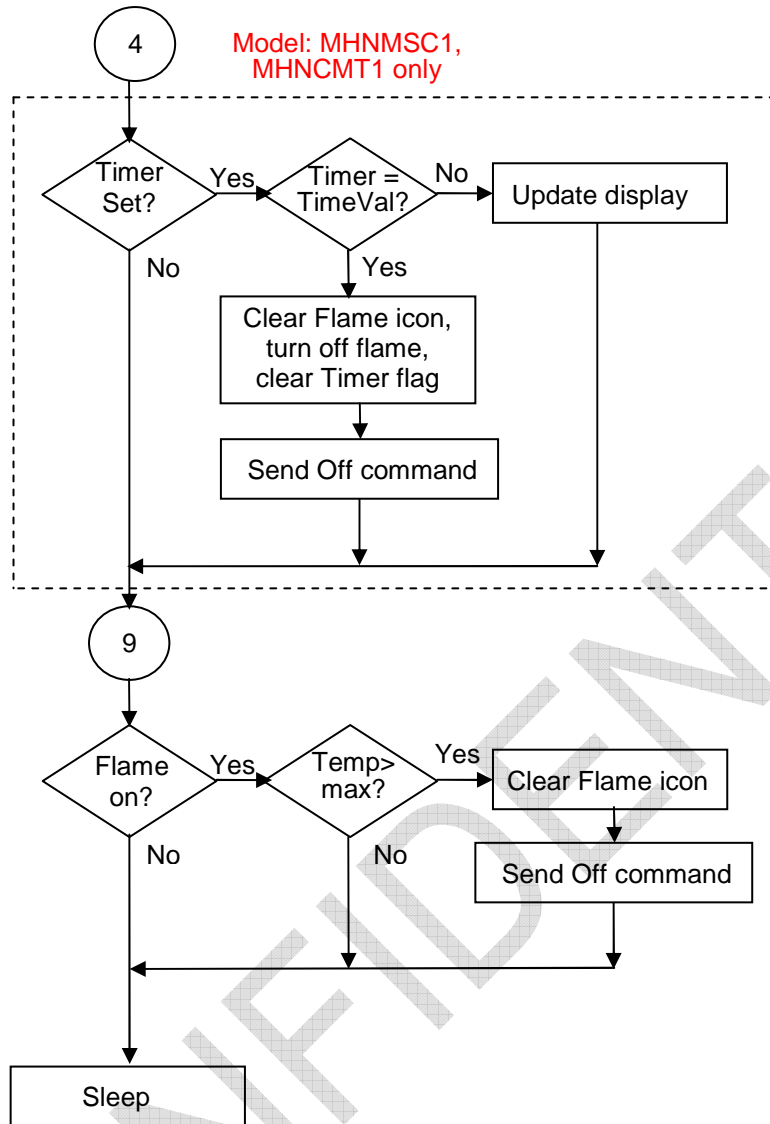

6.3 Timer interrupt

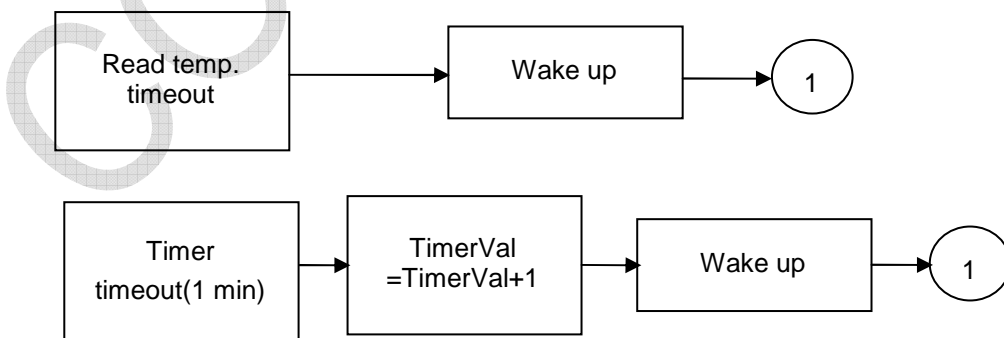

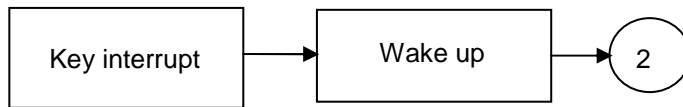

7 Mechanical specification

8 Regulatory specifications

FCC Comply.

9 Environmental specifications

Operating temperature: 0-50°C .

Storage temperature: -10-60°C .

5-90% Humidity

10 Quality

- Quality parameters: all products must be fir for function. Any deviations from the product Specification will be considered a defect and will cause rejection of the product.
- Product life expectancy is 5 years, based on 5000 hours usage per year.
- Workmanship: All parts shall meet the IPC-A-610D.

11 Design test requirements

a). Life Testing

Sample size of 10 units must survive ALT equivalent to 15000 hours.

d). ESD 8KV Class B.

12 Warranty period

One Year

13 Packaging

TBA

FCC Statement

This device complies with part 15 of the FCC Rules. Operation is subject to the following two conditions: (1) this device may not cause harmful interference, and (2) this device must accept any interference received, including interference that may cause undesired operation.

This equipment has been tested and found to comply with the limits for a Class B digital device, pursuant to Part 15 of the FCC Rules. These limits are designed to provide reasonable protection against harmful interference in a residential installation. This equipment generates, uses and can radiate radio frequency energy and, if not installed and used in accordance with the instructions, may cause harmful interference to radio communications. However, there is no guarantee that interference will not occur in a particular installation.

If this equipment does cause harmful interference to radio or television reception, which can be determined by turning the equipment off and on, the user is encouraged to try to correct the interference by one or more of the following measures:

- Reorient or relocate the receiving antenna.
- Increase the separation between the equipment and receiver.
- Connect the equipment into an outlet on a circuit different from that to which the receiver is connected.
- Consult the dealer or an experienced radio/TV technician for help.

Changes or modifications not expressly approved by the party responsible for compliance could void your authority to operate the equipment.

Canada – Industry Canada (IC)

This device complies with Industry Canada's licence-exempt RSSs. Operation is subject to the following two conditions:

- (1) This device may not cause interference; and
- (2) This device must accept any interference, including interference that may cause undesired operation of the device.

Cet appareil est conforme aux CNR exemptes de licence d'Industrie Canada . Son fonctionnement est soumis aux deux conditions suivantes :

- (1) Ce dispositif ne peut causer d'interférences ; et
- (2) Ce dispositif doit accepter toute interférence , y compris les interférences qui peuvent causer un mauvais fonctionnement de l'appareil.