

Touch Light On/Off Remote Control INSTALLATION AND OPERATING INSTRUCTIONS

This wireless wall on/off/ remote control – system provides a safe, reliable, and user-friendly remote control for millivolt valve gas appliances. The system can be manually turned on and off with the transmitter. Always check the appliance home owner’s manual for additional information, or warnings regarding accessory installation before connecting this remote control system.

Carefully inspect the contents for shipping damage. If any parts are missing or damaged, immediately contact the dealer from whom you purchased the kit. Do not attempt to install any part of the kit unless all parts are in good condition. Please keep this booklet for future reference.

CONTENTS OF KIT

Description	Qty
Touch Light Transmitter	1
Battery Alkaline AA (for Transmitter and receiver)	6
Receiver (Assembly) consists of :	1
Receiver Box	
Slide Button-Black (On/RS/Off)	
L-Bracket (Floor Mount)	
Wall Cover Plate-Black	1
Wall Cover Plate-White	1
Slide Button-White (On/RS/Off)	1
Screws (for Wall Cover Plate)	2
Plug-In Wiring Assembly – 18" Inches	1
Velcro (Loop and Hook)	1
Wall Anchor Screws	2
Wall Anchor	2
Installation Instructions	1
Screws (for fireplace system control covers)	2
Wall Bracket	1

FEATURES/SPECIFICATIONS

- Contemporary Ergonomic Table Top or Wall Mount Transmitter with Large LCD Display
- Battery Powered Transmitter and Receiver
- Easy Access Battery Door
- Pre-Programmed for Quick Installation
- Low battery Indication
- Child Proof Lock-out
- 128 Security Codes
- 2 hour Shut Down (Optional)
- Thermal Safety Shutdown (Transmitter Only)
- Quick Disconnect Wiring Assembly
- Reset Button

WARNING Important Safety Information

- Read this manual thoroughly prior to installing, programming or operating any remote control.
- This remote control system is designed for use with a milli volt gas valve system. Do not use this remote control system on applications with voltages above 24 Volts DC and 1 amp current.
- This remote control system requires two (2) "AA" alkaline batteries for the transmitter and four (4) "AA" alkaline batteries for the receiver.
- Wiring must conform to appliance requirement and building codes/ordinances as required by local and national code authorities having jurisdiction.
- Do not short (or jumper) across the gas valve terminals to test the remote control installation. This could damage the unit and void the warranty.
- This remote control system should only be used as described in this manual. Any other use is not recommended and will void the warranty.

WARNING

Due to the sensitive temperature monitoring components in the transmitter, it is necessary to allow the transmitter to stabilize to room temperature before accurate room temperatures are displayed. If the transmitter is activated from a severe cold condition, allow 15 minutes for accurate temperature readings to appear on the LCD.

NOTE

Turn appliance OFF and allow to cool before installing or servicing. DO NOT connect 110-120 VAC wiring to the milli-volt gas control valve. The remote operator must be installed exactly as outlined in these instructions. Read all instructions completely before attempting installation. Follow instructions carefully during installation. Any modification of components will void the warranty and may cause a fire hazard.

WARNING

Turn appliance OFF (at the appliance or remote receiver) if you are away from your house for a long period of time. Never leave anything on top of the surface on the touch light transmitter.

INSTALLATIONS

Remote Receiver:

The remote receiver may be wall mounted or installed in the appliance per the appliance homeowner’s manual. Refer to the Homeowner’s Manual for special installation instructions. If wall mounted, the remote receiver must be installed in a junction box with cover plate provided. Failure to follow the installation instructions found in the appropriate Homeowner’s Manual will void the warranty and may cause a fire hazard.

Installing Batteries:

The remote receiver uses four (4) "AA"- size batteries. To install batteries,

1. Remove the slide switch by gently pulling straight out.
2. Use your thumb and index finger to gently pull down the L-bracket.
3. Open the battery door by pressing the two tabs located on the door.
4. Install the batteries as indicated in the receiver cover.
5. Close the battery door until the door tab snaps in place.
6. To install the receiver into a wall junction box, install the receiver with the screws provided .
7. If you decided to install the receiver into the appliance, reinstall the L-bracket.
8. Gently, install the slide switch back to the receiver stem.
9. The batteries should be replaced at least once every 6 months or when the battery indicator flashes.

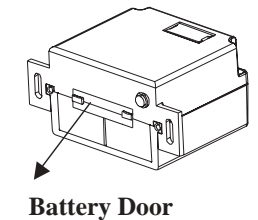
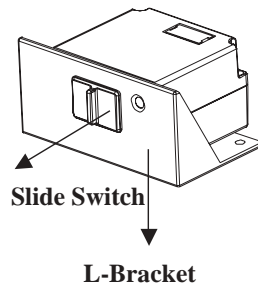

Connect the wiring terminal two (2) 1/4" female spade terminals to the appliance. Refer to the appropriate Homeowner’s Manual for proper wiring connections to the appliance. Your appliance may have other options to connect wiring from receiver. For applications longer than 18 inches, use 18 gauge wire, 105°C rated, with no splices. Connect to the two (2) 1/4" female spade wiring terminals. Wire can be no longer than 20 feet.

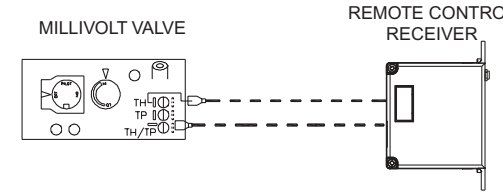

GENERIC WIRING DIAGRAM FOR RECEIVER. THE RECEIVER WIRE NEED TO CONNECT TO THE VALVE AT THE "TH" AND "TH/TP" JUNCTION

WARNING

Make sure that the wires do not contact the appliances any place other than at the terminals. Exposure to temperatures higher than 105°C (250°F) may cause the receiver to malfunction or fire hazard.

Touch Light Transmitter:

Installing Batteries:

The Touch Light transmitter uses two (2) "AA"- size batteries. To install batteries,

1. Press down the battery door tab and lift up and remove the battery door.
2. Install the battery.
3. Close the battery door by snapping in place
4. Repeat the above step for the other battery.
5. When both batteries are installed, the transmitter will initialize for 10 seconds and then is ready for use.
6. The batteries should be replaced at least once every 6 months or when the battery icon indicator flashes.

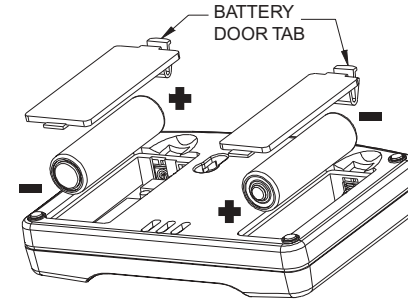

Setting Privacy (DIP) Switch on Receiver and Transmitter:

The remote receiver and transmitter privacy (DIP) switches are preset at the factory. In the event of activation or interference from other nearby transmissions, reset the code using the following procedure:

1. Slide the code switches on the transmitter or receiver to your choice of ON or OFF position. Switches #1 to #4 are preset to "ON" for both the transmitter and receiver.
2. The switches on the transmitter and receiver must match in order for the system to work.
3. To check, touch the transmitter groove surfaces for at least 1 second and release, the transmitter will emit a beep, and the receiver indicator light will blink. If not repeat step 2.
4. The system is now ready to operate.

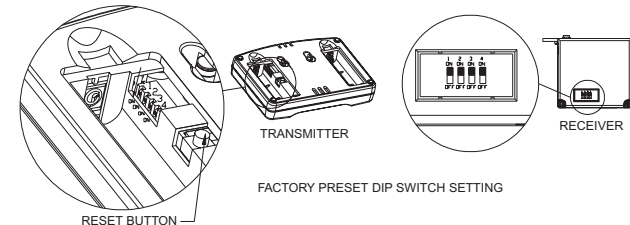

WARNING

Do not use two (2) or more remote control systems in the same area with the same dip switch settings, as they will communicate with each other. This may cause the appliances to malfunction.

Auto Shutdown:

1. The Touch Light transmitter comes preset from the factory with a 2 hour shutdown from its last ON operation. This is done to prevent the appliance from continuing to run if unattended.
2. You may disable this feature if you wish. To disable, change the Touch Light transmitter privacy (DIP) switch #1 ONLY to the OFF position (by sliding the switch towards the battery door.) Make sure the receiver privacy (DIP) switches are set the same. Follow the instructions on how to set the privacy (DIP) switch setting.

Reset Button:

1. The reset button can be used to reset the transmitter if transmitter is not working properly. The reset button is located behind the battery door cover. Using a paper clip, press the reset button and the transmitter will reset and initialize for 10 seconds before it can be used.

Where to place Touch Light Transmitter?

1. The Touch Light transmitter is recommended to be placed on a non metal table top or wall mount. Make sure there is no direct contact of metal parts to the body of the transmitter.
2. If wall mount, choose a mounting location about 5 feet above the floor in an area with good air circulation and away from the following:
 - a. Air ducts
 - b. Radiant heat from the sun and appliances
 - c. Concealed pipes and chimneys
3. Align the wall bracket to the desired location. Mark two (2) holes using the wall bracket as template.
4. Drill two (2) holes and insert the plastic anchors until they are flush with the wall.
5. Fasten securely the wall bracket to the wall with the two (2) screws.
6. Refer to the figure on how to install the transmitter to the wall bracket.

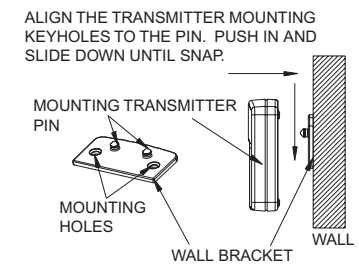

OPERATIONS:

Transmitter: General:

The TLM is a touch sensitive On/Off remote control system.

The transmitter will operate the remote receiver from 1foot to a maximum of 30 feet. The operational range is reduced when batteries are low or when the receiver is inside a metal enclosure.

Initial start up:

1. After initial power up or reset button is pressed, the transmitter is reset.
2. During transmitter reset, all segments of the LCD will be turned on. After ten (10) seconds, the LCD will be initialized and operational. You will hear a beep during this time.
3. After reset, only the room temperature will be displayed on the LCD display.

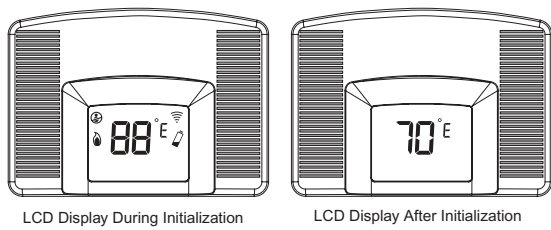

Manual Mode- On or Off Operation:

1. Since Touch Light transmitter is touch sensitive equipment, we recommend to use only your index finger to touch. Do not use any metal object to contact or touch the surface. The transmitter will recognize a valid touch if either side of the surface area are covered more than 10% for a period of **at least 2 second**.
2. To activate a signal, you need to touch either side of the groove surfaces for **at least 2 second** and then release your finger. If the touch is valid, it will beep once and a signal will be sent to the receiver. During this time you will see the transmission icon on the LCD display for a brief time. **No other command can be given until the transmission is completed.**

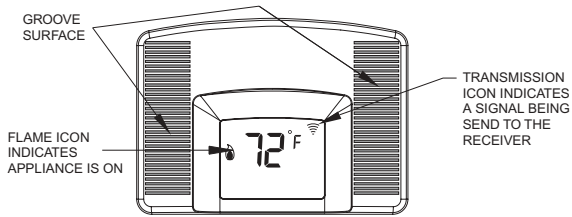

Child-proof protection:

1. Touch both sides of the groove surface with your two index fingers simultaneously for at least 3 seconds to enter child-proof mode. Once you hear two (2) beeps and the child proof icon appears on the LCD display, the child proof mode is activated. You will not able to turn the appliance on or off in this mode.
2. Always place both fingers on the middle of the groove surfaces to ensure a proper touch.
3. To deactivate child proof, repeat step 1. You will hear two (2) beeps and the child proof icon will disappear.

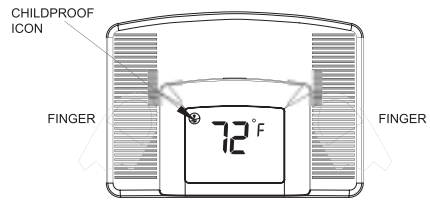

10 Seconds Continuous Touch Auto Shut Off:

1. If a metal object, (i.e. car key) or your hand is resting continuously for more than ten (10) seconds on either side of the groove surfaces (**NOT BOTH SURFACES**), the transmitter will emit three (3) beeps and send an off signal to turn off the appliance. Once the object is removed from the groove surfaces, the transmitter will remain in the off state until your next valid touch. **Never leave anything on top of the surface of the touch light transmitter to prevent undesirable operation.**

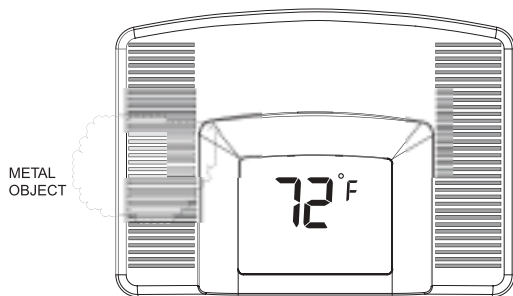

Low-battery detection:

1. Battery voltage is checked once a minute. When the battery voltage drops to a certain level, the low-battery warning will come on, and the transmitter will emit three (3) beeps and send signals to **turn off the appliance**. The transmitter will not function anymore until new batteries are installed.

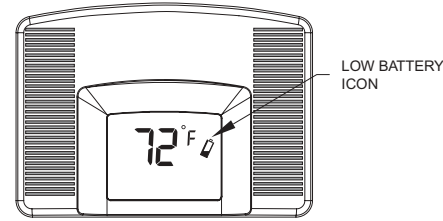

2. When the batteries are low, the LCD shows a blinking low battery indicator.
3. Change the battery every six months before the battery is too weak for normal operation. **TURN THE UNIT OFF BEFORE REPLACING BATTERIES.**

Touch Light Transmitter Thermal Shutdown:

1. If transmitter measures a room temperature exceeding 99 degrees Fahrenheit, the LCD will display "HI", emit three (3) beeps and send an off signal to **turn off the appliance**.
2. Transmitter will not function until the room temperature has dropped below 99 degree Fahrenheit.
3. If transmitter measures a room temperature less than 40 degrees Fahrenheit, the LCD will display "LO", and **no signals will be sent to turn on the appliance.**

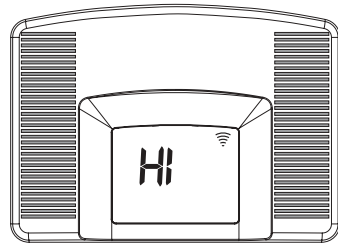

Receiver:

Slide Switch:

1. ON position: the system will remain on until the slide switch is placed in the OFF or RS position.
2. RS position: the system will only operate if the remote receiver receives a signal from the transmitter.
3. OFF position, the system is off. The slide switch should be placed in the OFF position if you will be away for an extended period of time. If the remote receiver is mounted out of children's reach, the OFF position also functions as a safety device by both turning the system off and rendering the receiver inoperable.

TESTING YOUR NEW REMOTE CONTROL SYSTEM

1. Light your gas appliance following the appliance lighting instructions that came with the appliance. Confirm that the pilot light is on; it must be in operation for the remote control to operate the main gas valve. Appliance control knob must be in the ON position. Appliance ON/OFF switch must be in OFF position.
2. Slide the 3 position button on the remote receiver to the ON position. The main gas flame should ignite.
3. Slide the button to OFF. The flame should extinguish (the pilot light will remain on).
4. Slide the button to RS (the center position), then touch the transmitter to turn the system to ON. The main gas flame should ignite.
5. Touch the transmitter to turn the system to OFF. The flame should extinguish (the pilot light will remain on).

TROUBLESHOOTING

Symptom	Causes	Action
1. LED light on receiver blinking or battery icon on LCD on transmitter. 2. LCD display is blank 3. LCD display shows "funny" display	1. Low Battery	1. Replace batteries. Change batteries every 6 months. 2. Check battery installation and replace batteries. 3. Press Reset button at the back of the transmitter.
4. Appliance does not come on after a valid touch (beep)	1. Wiring / Electrical Connections 2. Privacy (DIP) switch setting on transmitter does not match receiver 3. Transmitter measures temperature exceeding 99 degrees Fahrenheit and shows "HI" on LCD 4. Distance between the transmitter and receiver is more than 30 feet	1. Slide the switch to ON, if appliance comes ON, wiring is not the cause. 2. If appliance does not come on, check wiring connections. 1. Make sure the transmitter and receiver have the same DIP switch settings. 1. Move transmitter to a cooler place and wait until temperature drops below 99 degree. 1. Make sure the operating distance is less than 30 feet
4. Receiver cannot receive signal.	1. Receiver is installed in an enclosure	1. Make sure the receiver is not located inside an enclosure.

WARNING: Changes or modifications to this unit not expressly approved by the party responsible for compliance could void the user's authority to operate the equipment.

NOTE: This equipment has been tested and found to comply with the limits for a Class B digital device, pursuant to Part 15 of the FCC Rules. These limits are designed to provide reasonable protection against harmful interference in a residential installation. This equipment generates uses and can radiate radio frequency energy and, if not installed and used in accordance with instructions, may cause harmful interference to radio communications. However, there is no guarantee that interference will not occur in a particular installation. If this equipment does cause harmful interference to radio or television reception, which can be determined by turning the equipment off and on, the user is encouraged to try to correct the interference by one or more of the following measures:

- Reorient or relocate the receiving antenna.
- Increase the separation between the equipment and receiver.
- Connect the equipment into an outlet on a circuit different from that to which the receiver is connected.
- Consult the dealer or an experienced radio/TV technician for help.

WARRANTY

This warranty gives you specific legal rights and you may also have other rights that vary from state to state or province to province. Answers to any questions regarding our limited warranty may be obtained by writing our corporate offices. Ambient Technologies warrants each new Ambient Technologies remote control against any defects that are due to faulty material or workmanship to the original owner, for a period of five years after the original date of purchase. This warranty and our liability does not apply to batteries, nor does it include damage to merchandise or the remote control resulting from accident, alteration, neglect, misuse, improper installation or any other failure to follow Ambient Technologies installation and operating instructions. Ambient Technologies agrees to repair or replace at its option any Ambient Technologies remote control under warranty provided it is returned postage prepaid to our warranty facility in a padded carton within the warranty period, with proof of the original date of purchase and a brief description of the malfunction. This limited warranty does not include the cost of removal or re-installation

Ambient Technologies
149 Cleveland Drive
Paris KY 40361

FOR TECHNICAL SUPPORT
CALL 800-398-6195

50D0092 Rev 2 May 2004