

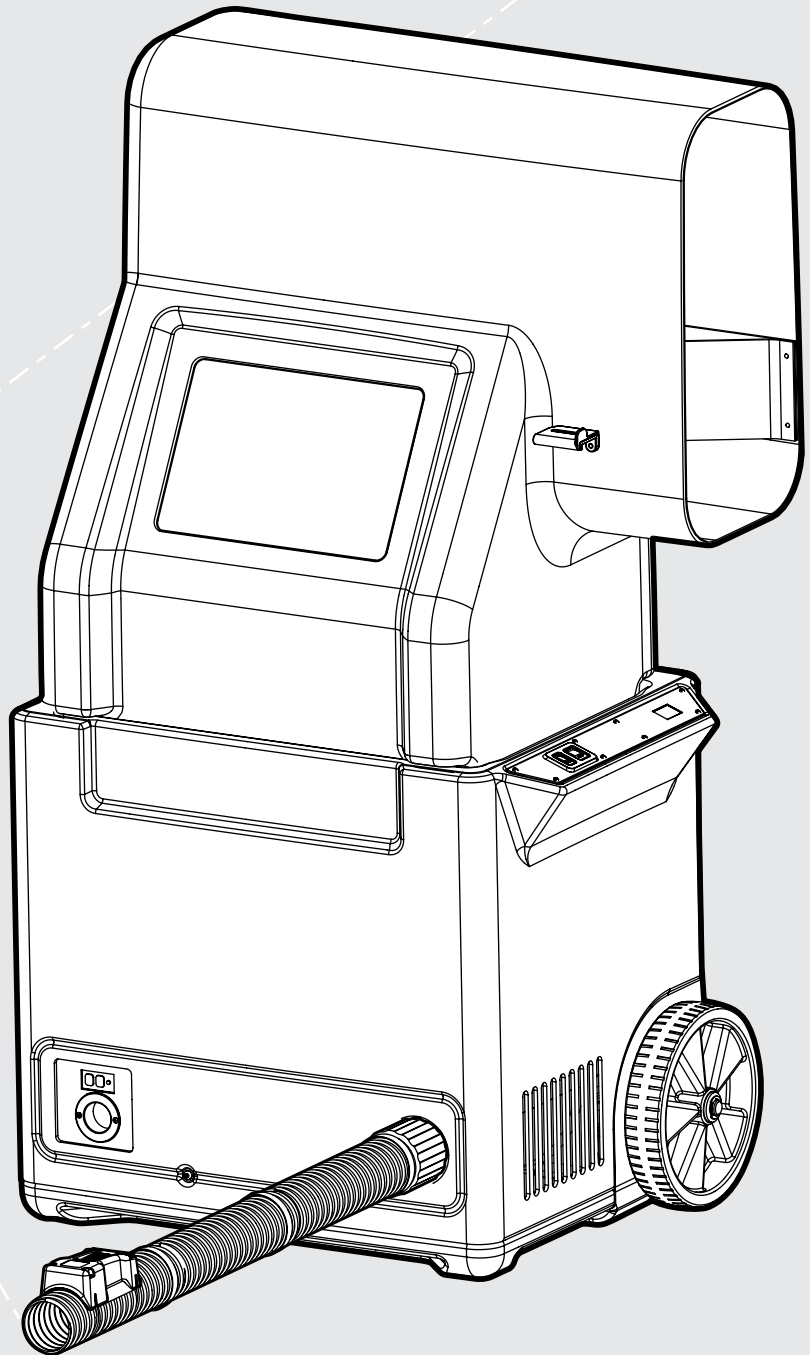

# AttiCat<sup>®</sup>

**EXPANDING BLOWN-IN  
INSULATION SYSTEM**

## OWNERS MANUAL



# TABLE OF CONTENTS

|  |    |
|--|----|
| Introduction and AttiCat® System Overview .....        | 3  |
| System Safety Features .....                           | 4  |
| Specifications .....                                   | 5  |
| Choosing an Extension Cord and Using a Generator ..... | 6  |
| Glossary .....   | 7  |
| Installation Instructions                              |    |
| Required Installation Materials .....                  | 8  |
| Personal Protective Equipment .....                    | 8  |
| Job Preparation .....                                  | 8  |
| How to Install .....                                   | 9  |
| Maintenance Inspections                                |    |
| Visual Inspection-External .....                       | 10 |
| Visual Inspection-Internal .....                       | 12 |
| Operational Inspection .....                           | 13 |
| Troubleshooting Guide .....                            | 15 |

# INTRODUCTION

This manual is provided with the AttiCat® Expanding Blown-in Insulation System developed by Owens Corning. This document is to be used to understand the system and to assist in the diagnosis and resolution of minor machine problems.

## SYSTEM OVERVIEW

The AttiCat® Expanding Blown-in Insulation System consists of:

- 1) a blowing machine,
- 2) the hose, and
- 3) the bags of expanding loosefill insulation.

The AttiCat® blowing machine consists of the feeder and the base. The feeder is the portion of the system where the operator inserts the insulation; a gravity feed guides the insulation down onto the agitator bars in the base. Paddles on the rotating agitators break apart the insulation into smaller pieces. Insulation flows through the agitators and into the revolving valve, and is then blown into the hose by the blower. The entire path - from agitators through the hose - is required to properly condition the insulation for use in the attic.

The hose is made up of two or three sections. Clamps are used to attach the sections together. The hose is attached to the base of the machine by a twist-on coupling. The attic end of the hose has a wireless remote control unit to start and stop the flow of insulation.

The system is completed by the bags of the loosefill blown-in insulation product. Each of the parts is integral to the proper operation and quality of the blown-in insulation process.

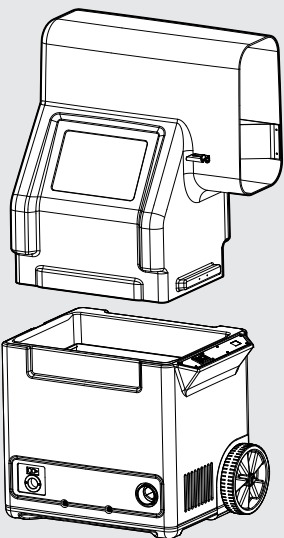

**1 MACHINE**

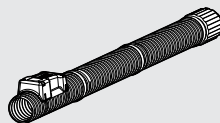

**2 HOSE**

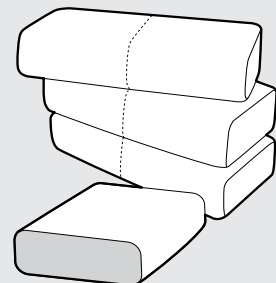

**3 BAGS OF INSULATION**

# SYSTEM SAFETY FEATURES

## FEEDER

The feeder is designed to enclose the insulation hopper to protect against injury by prohibiting easy access to the agitator bars within the base unit while the machine is running.

The machine will not run if the feeder is not attached. This further protects the operator from the moving agitator bars and possible injury.



## AUTOCUTTER

The AUTOCUTTER assembly completely encloses a standard utility knife blade. A blade guard on the inside of the feeder protects users from any cutting injuries.

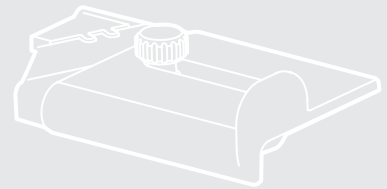

## CENTER OF GRAVITY

Most of the machine's mass is concentrated in the lower unit, creating a very stable machine despite its height. (CAUTION: The base unit should be lifted by two people.) The center of gravity also enables the machine to be easily tipped slightly and wheeled around like a dolly by one person.



# SPECIFICATIONS

**IMPORTANT NOTE: Use only AttiCat® Blown-in PINK Fiberglas™ Insulation. Other Materials May Damage the Machine and Void the Warranty**

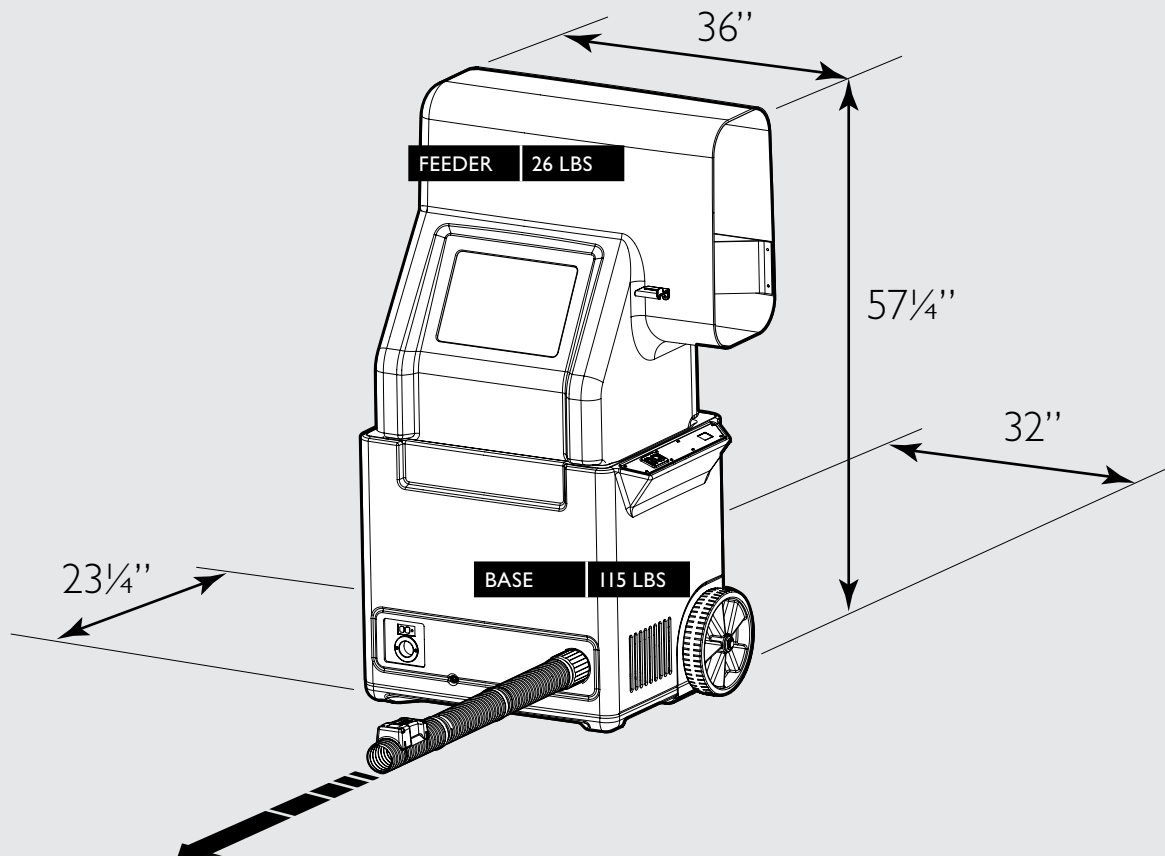

## PRODUCTION RATE

Approximately 7 pounds/minute, or 4-5 minutes/Bag

## HOSE DIAMETER

2 1/2"

## ELECTRIC

115 VAC 60HTZ requires one (1) 15 amp circuit to operate

## WEIGHT

141 lbs Machine only  
206 lbs shipping

# GENERATORS AND EXTENSION CORDS

Your AttiCat® machine will operate on power from a commercial-sized generator. No household generators may be used due to the high inrush requirements of the AttiCat® machine. **Also, generators made by Honda, Yamaha, Coleman and Generac are not recommended.** While they are of high quality, these generators do not have the inrush protection devices necessary to start the AttiCat® machine and protect the generator. The start-up requirement for the AttiCat® machine is 2000 watts; normal operating requirement is 1600 watts. **We recommend a generator of not less than 3000 watts, 115 VAC.** In addition, the AttiCat® Manufacturer recommends generators with a 50% power boost feature that aids the generator in high current startups.

Running additional equipment from the same generator means you will need to know the total electrical requirements before selecting the correct size of generator. For details on selecting and purchasing a generator, please call 1-800-GET PINK™.

An input line reactor will protect the AttiCat® electronics from transient overvoltage conditions and harmful harmonic distortions (over 10%) which are common problems with electronic generators. If you plan to power the AttiCat® machine from a generator other than as specified by the AttiCat® manufacturer, contact the AttiCat® manufacturer to purchase the input line reactor. This particular line reactor is made specifically for machines utilizing a Variable Frequency Drive such as used by the AttiCat® machine. It is enclosed in a weather-proof box designed for proper heat dissipation. The box can be either mounted on the AttiCat® machine or at the generator.

## Choosing the Correct Extension cord

Use only a three conductor, grounded, 14 gauge, 15 amp extension cord, 100 feet maximum.

### Note:

1. Adding Additional Power Cords will damage the machine and void your Warranty.
2. Using a generator of insufficient size or incorrect type will void your Warranty.

# GLOSSARY

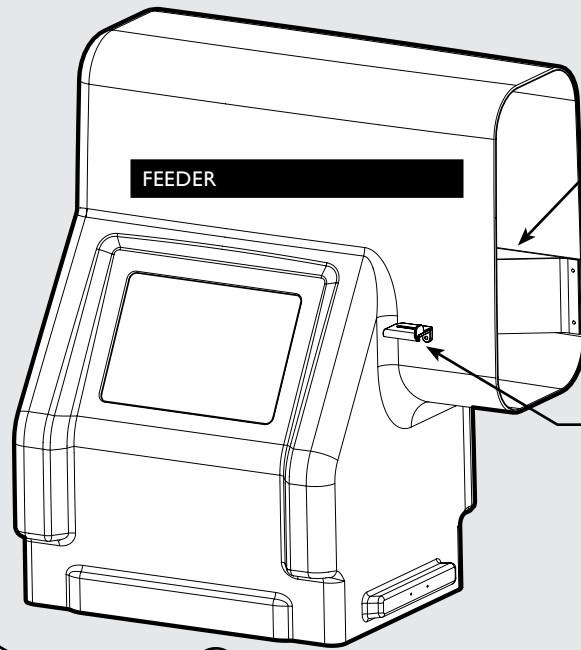

**BAIL GUIDE**  
 Folded plastic part inside feeder opening used to guide half-bags of insulation toward the AUTOCUTTER so the package can be cut, opened and released easily into the feeder.

**LATCH**  
 Attaches the feeder to the base unit. (On rear of feeder.)

**AUTOCUTTER**  
 Small utility blade attachment used to cut each half-bag of insulation when fed into machine.

**AGITATOR PADDLES**  
 Rubber ends riveted to the agitator bars.

**AGITATOR BARS**  
 Aluminum arms that hold the riveted rubber agitator paddles.

**AGITATOR SHAFTS**  
 Attached to the agitator shafts (revolve within the base unit to break apart the blown-in insulation material.)

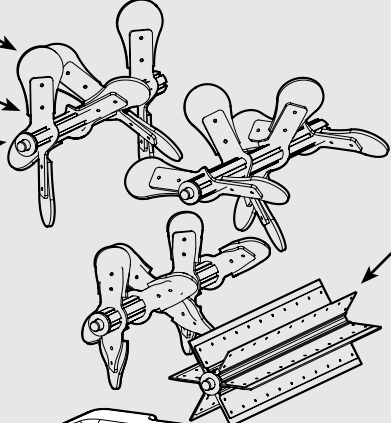

**VALVE**  
 Revolving vanes attached to the blower (blown-in insulation is grabbed by the six (6) vanes and blown into the hose.)

**CONTROL PANEL**  
 Allows operator to start and stop the machine.

**GFCI**  
 Ground Fault Circuit Interrupter; Shuts down the current flow when a ground fault is detected to protect the user from electrical shock.

**ELECTRICAL INLET**  
 14-gauge, 15-amp extension cord attaches here.

**AIR INTAKE VENTS**  
 Take air into the base unit; covered with screens to keep debris from being pulled into the machine.

**WHEELS**  
 Allow machine to be tipped back and moved around like a dolly.

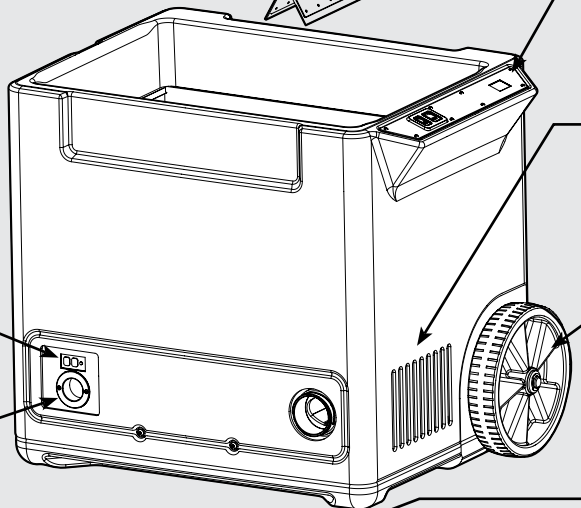

**HOSE COUPLING**  
 Machine end of hose has twist-on hose attachment allowing entire hose to be securely attached to base unit.

**ATTIC WIRELESS REMOTE**  
 Attic end of hose has ATTIC REMOTE controlling machine from attic.

**HOSE**  
 Hose sections are attached to each other with hose clamps; entire hose is attached to machine with twist-on hose coupling.

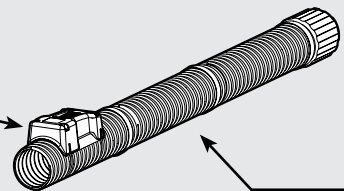

# OPERATING INSTRUCTIONS

## Personal Protective Equipment

- Protective clothing and equipment, including a properly fitted NIOSH or MSHA approved disposable dust respirator (such as 3M Model 8210, Model 8271 for high-humidity environments, or equivalent), gloves, goggles, and a long-sleeve shirt and pants.

## Job Preparation

- Examine your attic to be sure it is adequately ventilated. Owens Corning recommends a minimum of 1 square foot of venting for every 150 square feet of space to be insulated.
- Install a rigid barrier around the attic access opening to prevent insulation from falling out when you open the attic door (Owens Corning FanFold Foam Residing Board; Foamular®, Insulpink®, or ProPink® Foam Insulation Board; or equivalent). Be sure the barrier is taller than the thickness of the insulation you plan to install.

## Required Installation Materials

- Bags of AttiCat® Blown-in PINK Fiberglas™ Insulation (calculate number of bags needed using the chart on the bag)
  - AttiCat® machine and hose assembly
  - Extension cord (three-conductor, with ground, 14-gauge, 15-amp)
  - Drop cloths
  - Eave or soffit ventilation baffling material, such as Owens Corning's raft-R-mate® attic vents
  - Cardboard or metal baffling
  - Knife to cut insulation bags
  - AttiCat® rulers and a marking pen
  - Staple gun
  - Lighting and a ladder to safely access attic
- 
- Inspect any duct work in the attic and make sure all connections are sound. If necessary, seal duct joints prior to installing insulation.
  - Place the AttiCat® machine outside of your house or in your garage.
  - Lay drop cloths in the house along the path of the hose to protect floors and other surfaces.
  - Run the hose into the attic. Extend enough hose to reach the furthest point in the attic. NOTE: AttiCat® machine shoots insulation a distance of approximately 8 to 10 feet.
  - The AttiCat® system works with two people—one in the attic installing and the other operating the machine.

## CAUTIONS

- Do not block eave venting (soffit vents) with insulation. Use vent baffles such as Owens Corning raft-R-mate® attic vents (or equivalent) between eave vents and attic to ensure air flow.
- When working in the attic, walk only on the ceiling rafters or joists and not on the ceiling. Be careful of overhead obstructions and nails penetrating through the roof deck.
- Maintain a minimum clearance of 3" around any heat-generating sources (lights, flues, etc.) in the attic. If a light fixture is labeled IC-rated, it is safe to lay insulation over it.



## WARNINGS

- KEEP HANDS AND TOOLS AWAY FROM ANY MOVING PARTS.
- DO NOT ATTEMPT TO CLEAN THE AttiCat® MACHINE OR HOSE UNTIL MACHINE IS COMPLETELY OFF AND EXTENSION CORD IS DISCONNECTED.
- NEVER OPERATE THE AttiCat® MACHINE IF IT OR THE OPERATOR IS STANDING IN WATER. SERIOUS INJURY MAY RESULT.

Owens Corning shall not be responsible for any injury, damage, loss, cost, expense, or liability relating to failure to follow these instructions. Failure to follow these insulation instructions may affect Owens Corning's obligations under this product's limited warranty.



# HOW TO INSTALL

## At the machine (person #1)

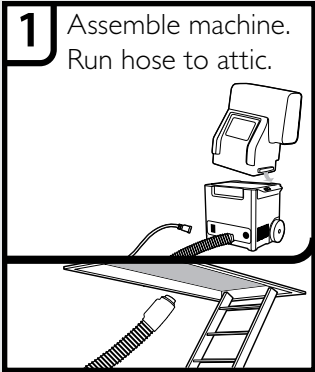

- Plug extension cord into AttiCat® machine; connect to a standard 115 V electrical outlet. Green light on control panel will illuminate.
- Connect hose to machine and take the other end into the attic.
- Feed only half bags to avoid jamming and damaging the machine. Using a knife, cut bag of insulation along cut line. Break package in half; machine's feeder is specifically designed to accommodate a half-bag of AttiCat® PINK Fiberglas™ Blown-in Insulation.
- Hold the half-bag by end flaps and insert cut end into machine. Push half-bag

- completely into feeder until it stops. The built-in Autocutter will cut plastic packaging thereby releasing insulation into the machine.
- Remove packaging from machine. **IMPORTANT! PACKAGING MAY CLOG MACHINE AND SHOULD BE REMOVED IMMEDIATELY ONCE FIBERGLASS IS RELEASED INTO FEEDER.**
- Do NOT attempt to forcefully push or hand-feed loose insulation down into machine.
- Add another half-bag of insulation once the machine feeder has emptied and the agitator paddles can be seen through window.

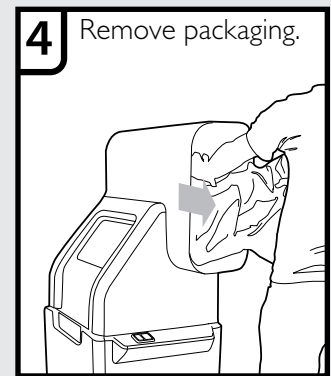
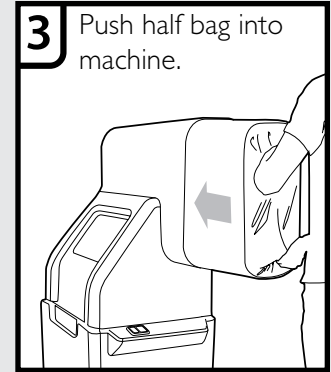

## In the Attic (person #2)

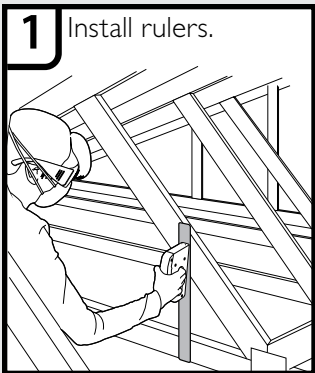

- Using a staple gun, install AttiCat® rulers on joists, roof trusses, or vertical framing to determine how much insulation you need to add. Install one per every 300 ft<sup>2</sup>/28 m<sup>2</sup> so that they are clearly visible.
- Install cardboard or metal baffling around heat-generating sources such as can lights or flues/metal chimneys; keep cardboard and insulation at least 3" from heat sources.
- Press the START button on the remote to begin flow of insulation. There will be a slight delay from the time the blower starts and the time the agitators begin rotating. To stop the flow of insulation at any time, press the STOP button on the

- remote; this will stop the AttiCat® machine.
- Direct the hose toward the eaves, and begin by blowing insulation at the point furthest from the attic opening. Insulation should flow out of the hose and fall onto the surface 8 to 10 feet away.
- As each attic section is filled, move slowly backward toward the attic opening. Repeat this process until attic is fully insulated.
- Ensure eaves vents and heat-generating fixtures are not covered with insulation.
- When you're close to the attic opening, use gloved hands to deflect the insulation downward.

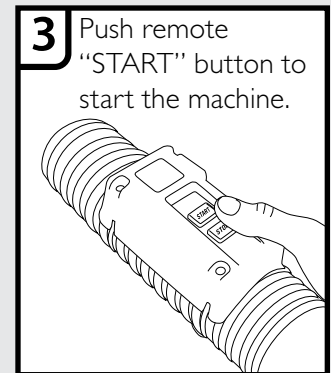

# VISUAL INSPECTION EXTERNAL

First, visually inspect all sides of the machine to check for cracks or other damage to the outside of the feeder and lower unit.

Then, thoroughly inspect the following assemblies, making sure they are still attached and in working order.

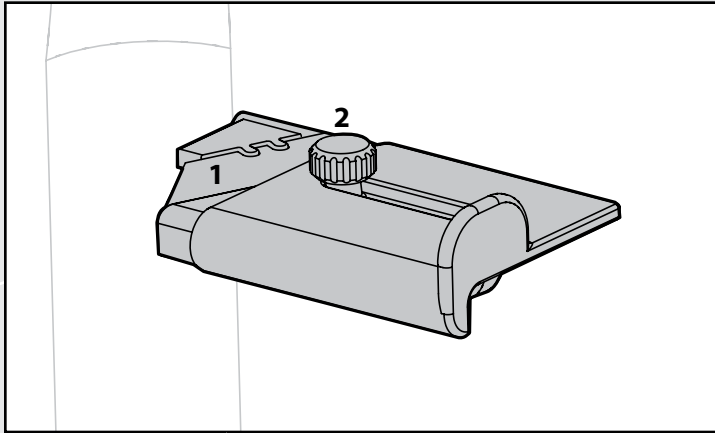

## AUTOCUTTER

Is the blade (1) present?  
Does the blade appear dull or damaged?  
Is the complete cutter assembly - including thumb screw (2) - intact?  
Is there insulation material blocking the blade?

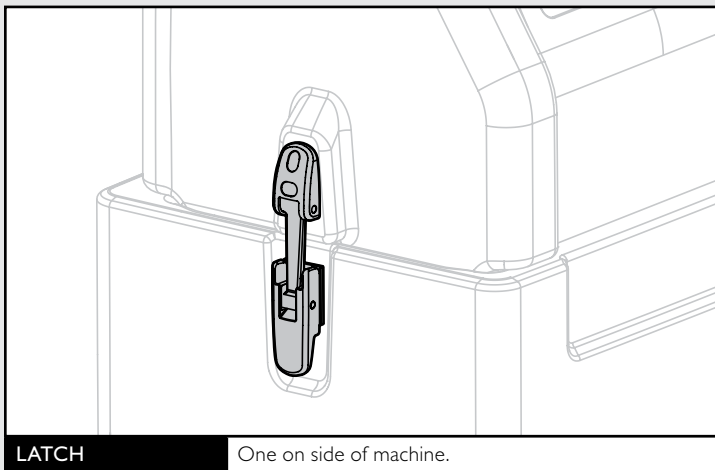

## LATCH

One on side of machine.

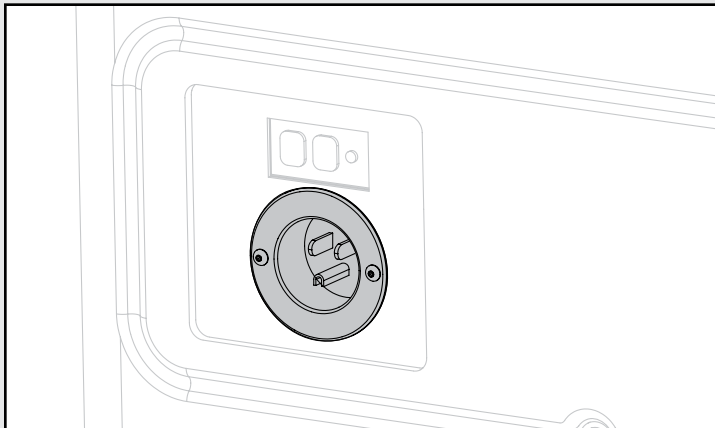

## ELECTRICAL CONNECTION

Is inlet panel damaged? Check for bent prongs or missing screws.

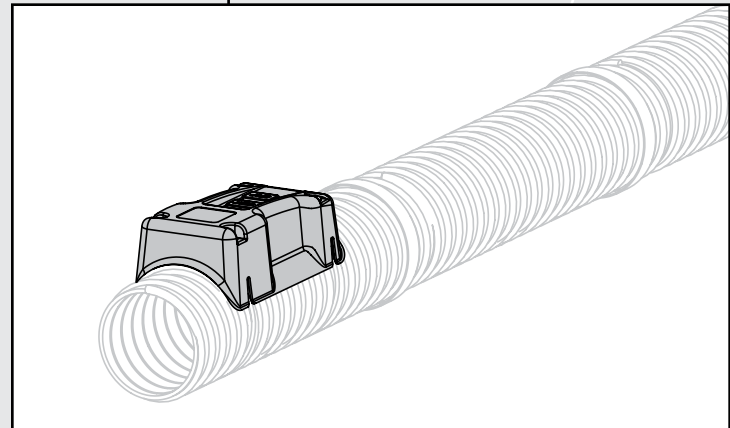
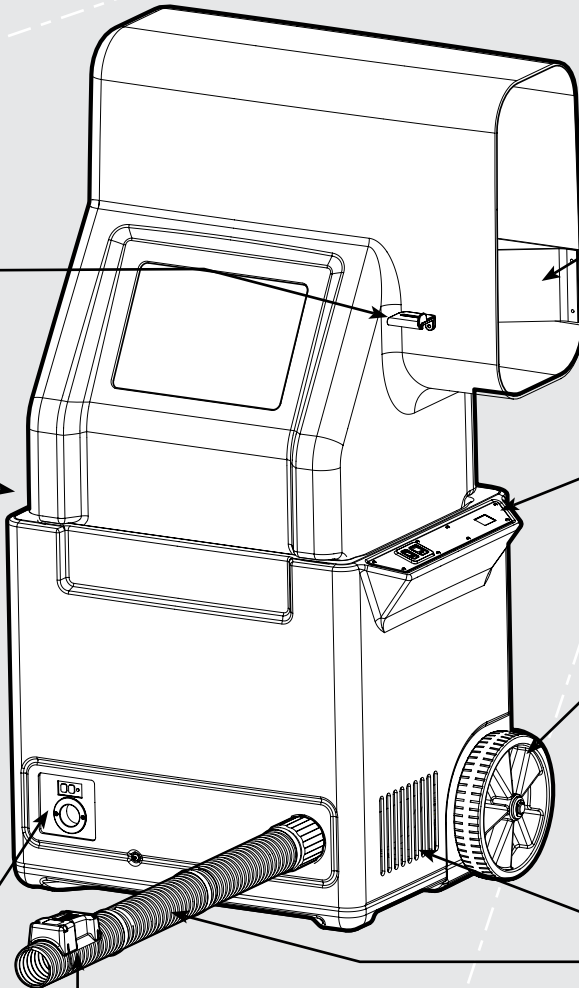

## ATTIC REMOTE

Is the remote missing or damaged?

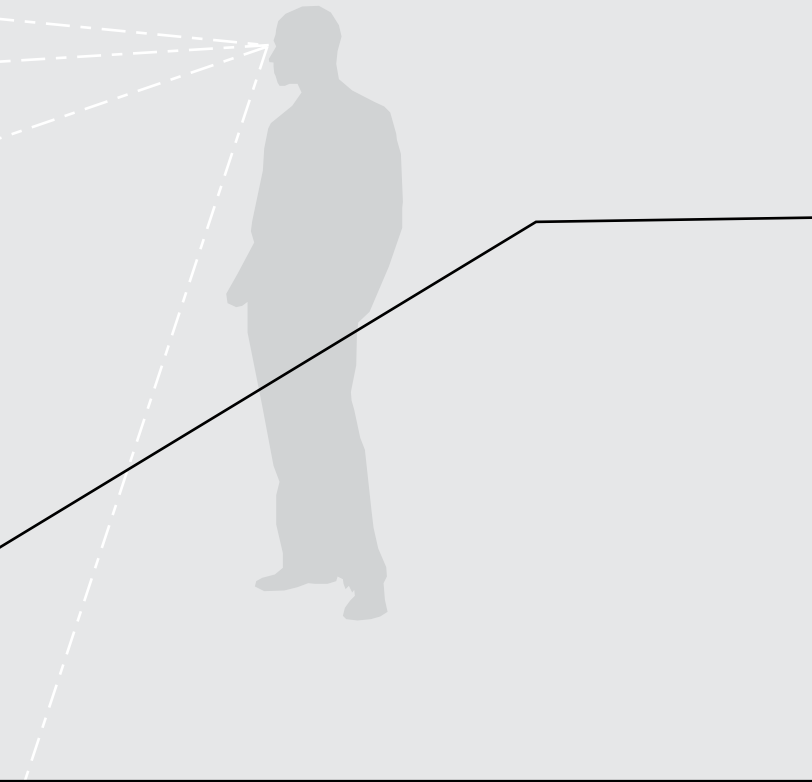

**NOTE:**  
Before beginning external inspection, be sure to turn off and unplug machine.

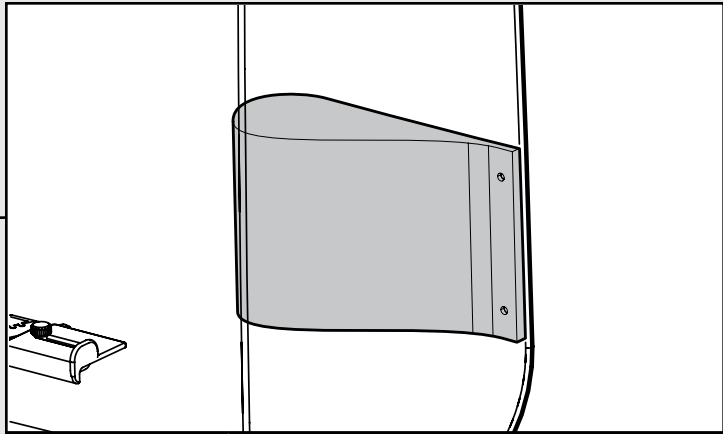

**BAIL GUIDE** Helps guide insulation into the machine.

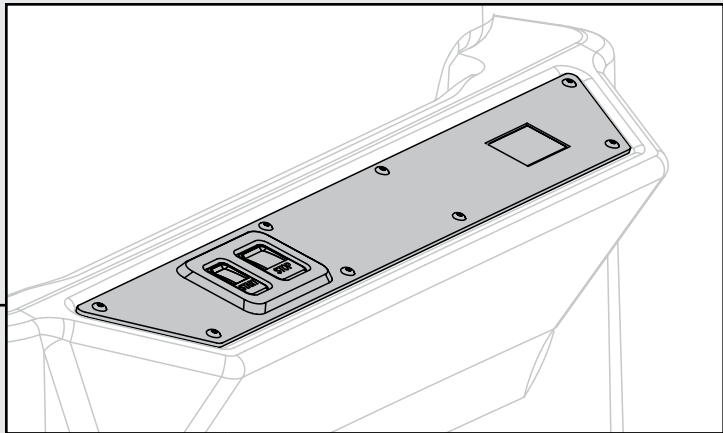

**CONTROL PANEL** Verify all buttons are present and not damaged.

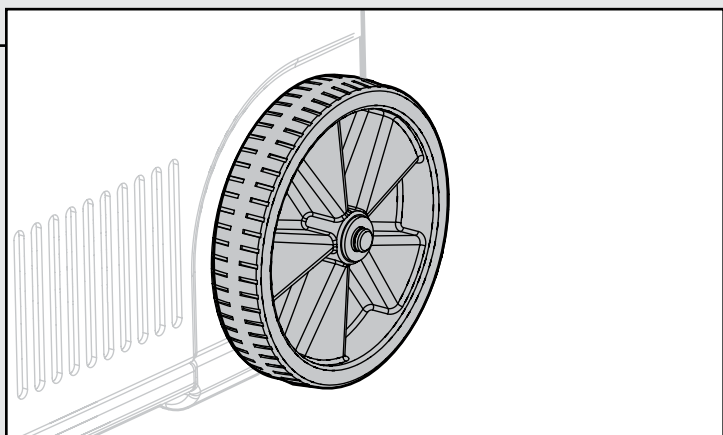

**WHEELS** Machine should have two wheels per base.

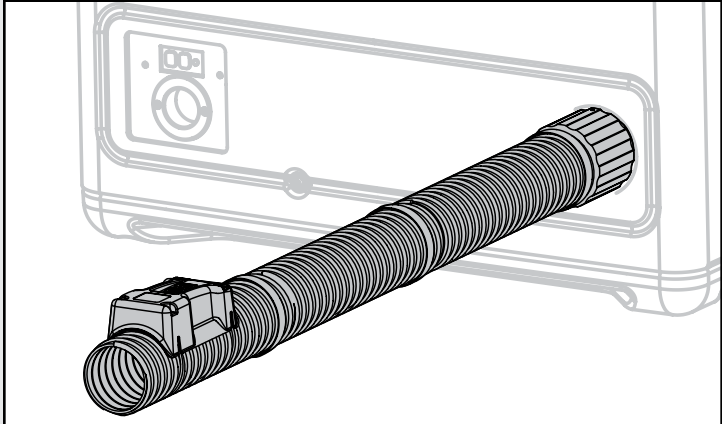

**HOSE ASSEMBLY** Is there a remote? Check hose for cracks, cuts or other damage, and presence of all couplers and clamps.

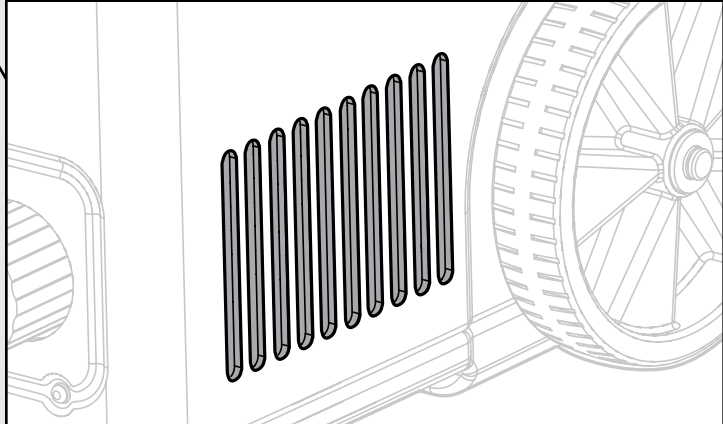

**INTAKE VENTS** Use a shop vac to remove accumulated insulation/ debris from vents (on both ends of machine)

# VISUAL INSPECTION INTERNAL



**NOTE:**  
Before beginning internal inspection, be sure to turn off and unplug machine.

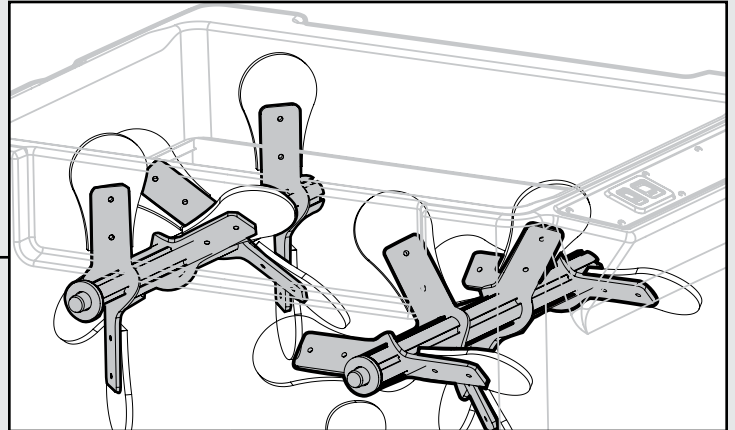
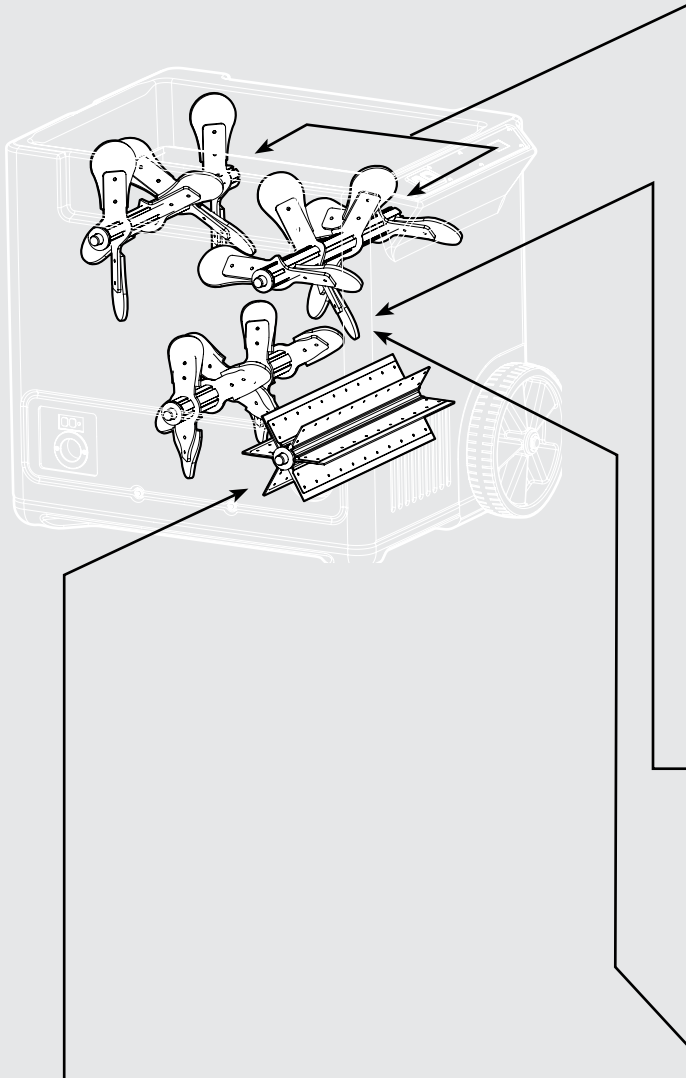

**UPPER AGITATORS** Verify that both upper agitators are not cracked or missing.

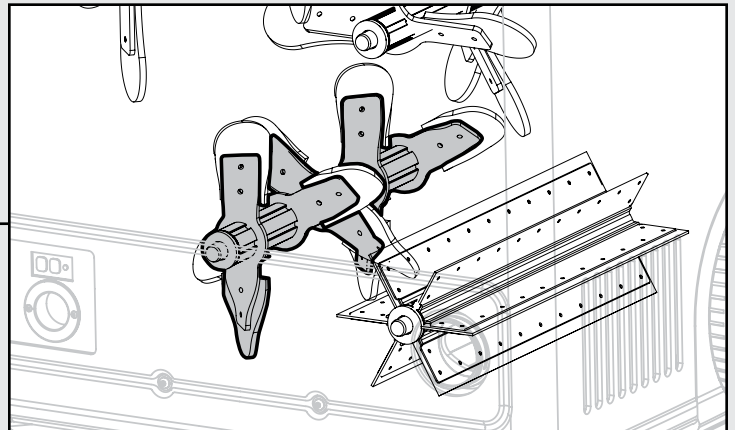

**LOWER AGITATOR** Verify that the lower agitator is not cracked or missing.

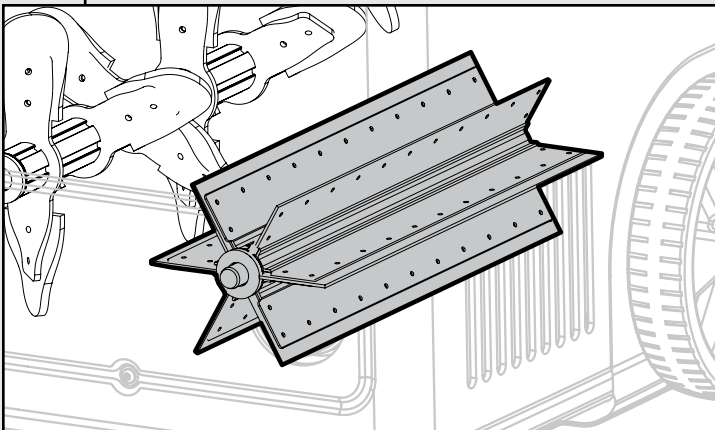

**VALVE (6 SEALS)** Check for bent, broken or cracked valve seals.

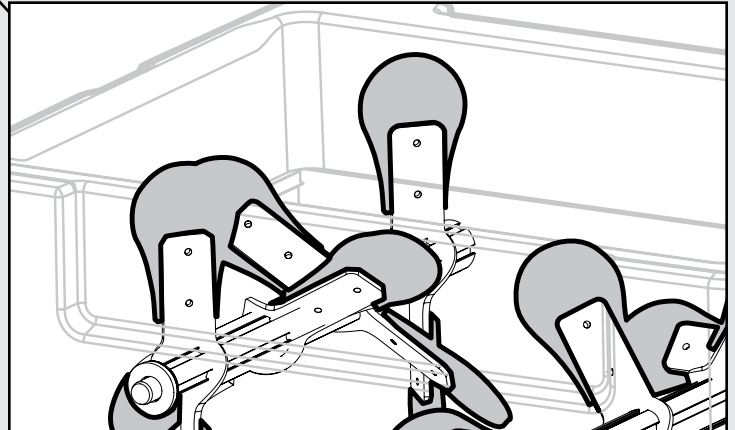

**PADDLES** Check for missing, loose, or damaged paddles.

# OPERATIONAL INSPECTION

Follow this short inspection to verify that the machine is in working order. Ensure no insulation is in the machine.

- 1 Connect complete hose assembly to hose port on base of machine.
- 2 Connect grounded (14 gauge, 15 amp) extension cord to three-pronged connector on lower unit of machine and then connect cord to a 115 volt electrical source.
- 3 Press Reset Button on the GFCI (may already be depressed).
- 4 Press the Start Button.
- 5 Observe agitators through inspection window to ensure they are turning.
- 6 Check for air flowing out the end of the hose.
- 7 Press the stop button to turn the machine off.
- 8 Press start button on the attic remote. Repeat steps 5 & 6.
- 9 Press Stop button on the attic remote.
- 10 Disconnect extension cord.

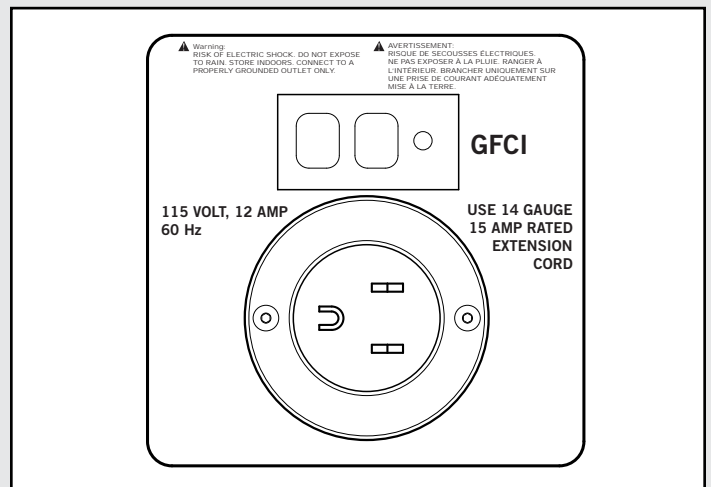
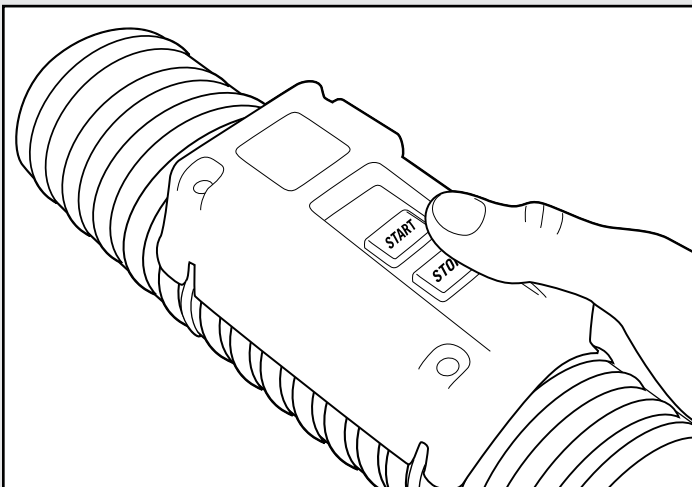

# OPERATIONAL INSPECTION CONTINUED

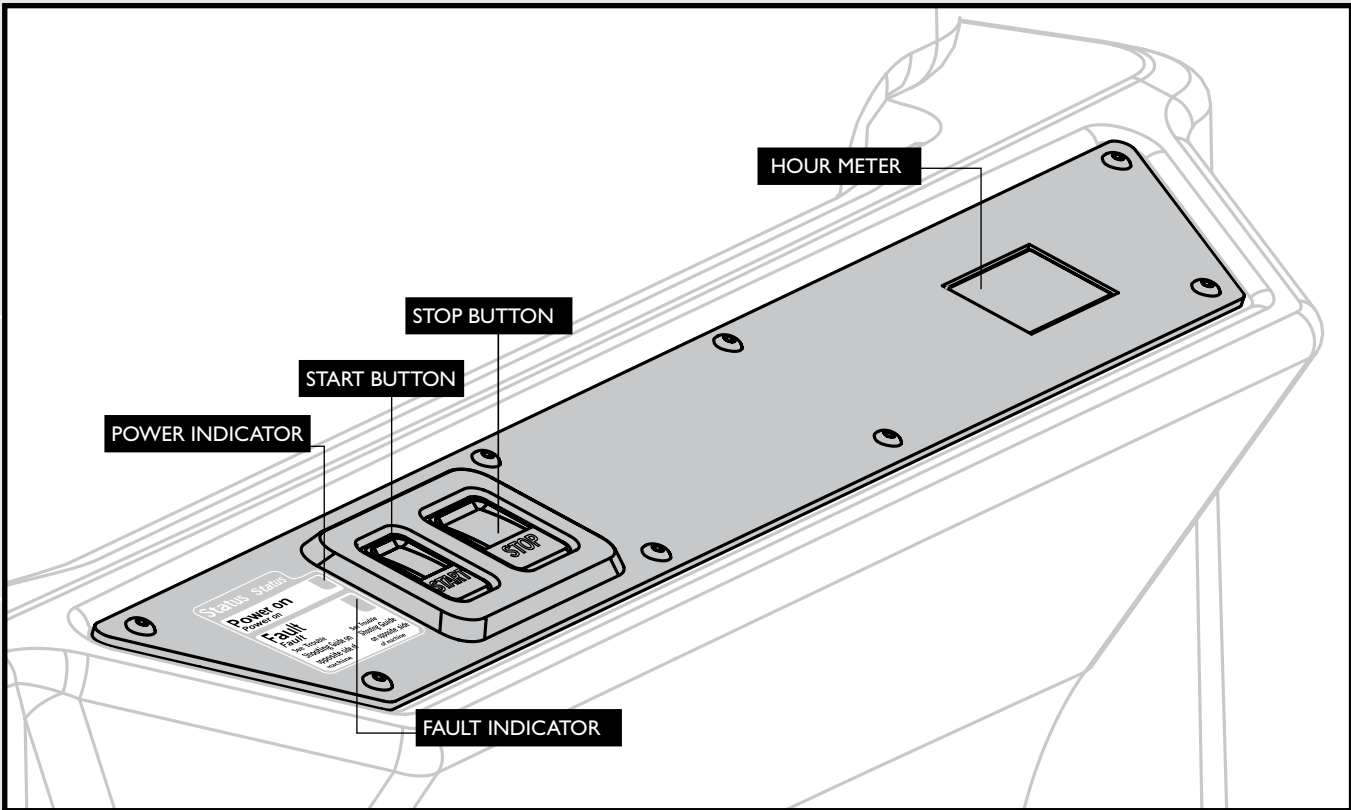

CONTROL PANEL

|                 |                     |   |
|-----------------|---------------------|---|
| POWER INDICATOR | WHEN LIT (GREEN)    | Electrical power is present, and the machine is ready to use. |
| FAULT INDICATOR | WHEN FLASHING (RED) | Indicates an agitator motor overload (jam).                   |
| START (GREEN)   | WHEN PRESSED        | Starts blower, then after 3 second delay, agitator starts.    |
| STOP (RED)      | WHEN PRESSED        | Stops both the agitator and blower operation.                 |
| HOUR METER      | DURING OPERATION    | Records the number of hours used.                             |

# TROUBLESHOOTING GUIDE

| PROBLEM   | POSSIBLE CAUSE   | SOLUTION   |
|---|--|--|
| Machine will NOT start and green Power Light is NOT on at Control Panel | Extension cord not plugged in to machine or wall outlet.         | Plug extension cord into machine and into standard 115V electrical outlet.   |
|   | GFCI (Ground Fault Circuit Interrupter) has been tripped.        | Reset the GFCI: <ul style="list-style-type: none"> <li>• Unplug the machine, wait 2 minutes and plug it back in.</li> <li>• Press reset.</li> <li>• If it continues, try another circuit and a new extension cord.</li> </ul>  |
|   | Circuit Breaker is turned off or tripped.                        | Check household circuit breakers or fuses.   |
|   | Feeder is not attached to base or not attached to base properly. | Make sure feeder is attached to base and latches are secured. Feeder must be placed with the feeder opening directly above the control panel.  |
| Fault light is FLASHING at Control Panel                                | A material jam has stopped the machine from running.             | Unplug machine. Remove feeder and clear material jam, then replace feeder. Plug machine in.  |
| ATTIC REMOTE does not work, but machine turns on at control panel.      | Battery is not working.  | Unscrew the 4 screws on top of the Attic Remote. Remove the remote and the 2 mounting rings from the hose.<br>Turn remote over and remove the screw holding the battery retainer.<br>Replace the 2 AAA batteries.<br>Reattach the battery retainer and place the remote and mounting rings back on the hose.<br>Secure the 4 screws to the mounting rings. |
|   | None of the above solutions works                                | Control the machine from the control panel.  |
| Machine Runs Slowly   | Low Voltage Circuit  | Plug into another electrical outlet on a different circuit   |
|   | Incorrect Power Cord   | Use specified extension cord   |

| <b>PROBLEM</b>  | <b>POSSIBLE CAUSE</b>   | <b>SOLUTION</b>  |
|---|---|--|
| Insulation not released from plastic packaging when inserted into machine feeder.         | The package of insulation was not cut in half.                                | Cut the package of insulation in half along dotted line on package.  |
|   | Too much insulation is being inserted into the machine at once.               | Insert only one half-bag into machine feeder at a time.  |
|   | The insulation is being inserted incorrectly into the machine.                | Insert the half-bag open (cut) end first; push half-bag fully to the far end of the feeder wall.   |
|   | There is no blade in the AUTOCUTTER or the blade is dull or broken.           | Turn off machine. Unplug extension cord. Insert standard utility knife blade into AUTOCUTTER assembly.   |
|   | Blade could be clogged with insulation.                                       | Unclog blade.  |
| Insulation released from plastic packaging, but machine appears to be jammed.             | Too much material is in the feeder.   | Check to see if any insulation is coming out of open end of hose.  |
|   | Insulation was pushed down into the machine.                                  | Check to see if insulation is flowing through machine by observing operation through inspection window.<br>Turn off machine. Unplug extension cord. Release latches and remove feeder from top of base. Remove insulation from base of machine.<br>Plug machine in, turn on, and press start button. |
| Insulation and air not coming out of hose.  | The hose is not attached.   | Attach the hose to the machine.  |
|   | There is a blockage in the hose.  | Remove hose and shake vigorously to dislodge insulation and resume flow.   |
| Air, but no insulation coming out of hose.  | Machine is jammed.  | See previous section.  |
|   | Either the agitators or valve are not turning.                                | Secure repair assistance.  |
| After inserting insulation into machine feeder, plastic packaging is difficult to remove. | Half-bag is not inserted all the way into the feeder and past the AUTOCUTTER. | Push half-bag horizontally all the way into machine feeder past AUTOCUTTER.  |
|   |   | Wait until insulation is released from the plastic packaging before attempting to remove plastic.  |



| <b>PROBLEM</b>   | <b>POSSIBLE CAUSE</b>                                 | <b>SOLUTION</b>  |
|--|---|--|
| Plastic packaging falls down into machine.   | User error.   | Turn off machine. Unplug extension cord. Release latch and remove feeder from top of base. Remove plastic packaging from lower portion of machine. Re-attach feeder. Resume use. |
| Machine is blowing insulation unusually slowly. The normal rate is approximately 7 lbs./minute or 4-5 minutes per bag. | Valve housing has lost pressure due to damaged vanes. | Call 1-800-GET-PINK to obtain repair service.  |
|  | Blower is not working properly.                       |  |
| <b>NONE OF THE SOLUTIONS SOLVES PROBLEM.</b>   |   | <b>Call 1-800-GET-PINK</b>   |

This device complies with Part 15 of the FCC Rules. Operation is subject to the following two conditions: (1) this device may not cause harmful interference, and (2) this device must accept any interference received, including interference that may cause undesired operation.

Changes or modifications not expressly approved by the party responsible for compliance could void the user's authority to operate the equipment.







**OWENS CORNING INSULATING SYSTEMS, LLC**  
ONE OWENS CORNING PARKWAY  
TOLEDO, OHIO 43659  
**1-800-GET-PINK™**  
**www.owenscorning.com**

INNOVATIONS FOR LIVING®

Pub. No. 10009316-A. Printed in U.S.A. June 2008. THE PINK PANTHER™ & ©1964-2008 Metro-Goldwyn-Mayer Studios Inc. All Rights Reserved. The color PINK is a registered trademark of Owens Corning. ©2008 Owens Corning.

