

Document No.

Rev. 1.4

Product Code WM-G-MR-09-Ref2
Product No.

Product Specification
of WM-G-MR-09-Ref2
Wireless LAN Module

Doc No.		Rev	1.4
Date.	2011/12/09	Page	3

INDEX

1	REVISION HISTORY	2
2	PURPOSE	4
3	SCOPE	4
	3.1 BLOCK DIAGRAM	4
4	GENERAL FEATURES	5
5	ELECTRICAL SPECIFICATION	6
5.1	SUPPLY VOLTAGE	6
5.2	RECOMMENDED OPERATION CONDITIONS	6
	5.2.1 <i>Temperature, humidity</i>	6
	5.2.2 <i>DC Electrical</i>	6
5.3	POWER CONSUMPTION (SDIO MODE)	7
5.4	WIRELESS SPECIFICATIONS	7
5.5	RADIO SPECIFICATION	8
6	INTERFACE	9
6.1	PIN DEFINITION	9
6.1.1	RECOMMENDED FOOTPRINT	12
6.2	SPEIFICATIONS AND TIMING DIAGRAM	13
	6.2.1 <i>External sleep clock specification</i>	13
	6.2.2 <i>SDIO protocol timing</i>	13
	6.2.3 <i>G-SPI protocol timing</i>	15
	6.2.4 <i>Networking Coexistence</i>	16
	6.2.5 <i>Reset and configuration timing</i>	16
	6.2.6 <i>LED Interface</i>	18
	6.2.7 <i>Antenna Interface</i>	18
7	REGULATORY	18
8	MECHANICAL SPECIFICATION	19
9	RECOMMENDED REFLOW PROFILE	20
10	PACKAGE AND STORAGE CONDITION	21
	10.1.1 <i>Package Dimension</i>	21
	10.1.2 <i>Laser Mark</i>	22
	10.1.3 <i>Part Order Numbering</i>	22
	10.1.4 <i>ESD Level</i>	22

2 PURPOSE

The purpose of this document is to define the product specification for 802.11b/g WiFi module WM-G-MR-09-Ref2.

3 SCOPE

- High speed for wireless LAN connection: IEEE802.11b/g up to 54Mbps data rate by incorporating Direct Sequence Spread Spectrum (DSSS) and OFDM data modulation.
- Provide seamless roaming within the IEEE 802.11b/g WLAN infrastructure.
- IEEE 802.11b/g compatible: allow inter-operation among multiple vendors.
- Auto fallback: 54M, 48M, 36M, 24M, 18M, 12M, 9M, 6M (802.11g); 11M, 5.5M, 2M, 1M (802.11b) data rate with auto fallback.
- WPA (Wi-Fi Protected Access)
- Support 802.11i Security standard through implementation of AES / CCMP and WEP with TKIP security mechanism.
- Support 802.11e Quality of Service (QoS)
- Interoperability – Complying with WECA WiFi.
- 3-wire, hardware signaling BT WiFi co-existence supported
- Compliant with RoHS

3.1 BLOCK DIAGRAM

The figure is WM-G-MR-09-Ref2 simple block diagram which provide WIFI B/G function. This module consists of Marvell 8686 chip and use simple antenna design concept. To avoid CDMA, GSM, PCS and WCDMA interfering signal, the blocking filter implemented in this module. Otherwise there is embedded 38.4MHz crystal in this module for WiFi chip.

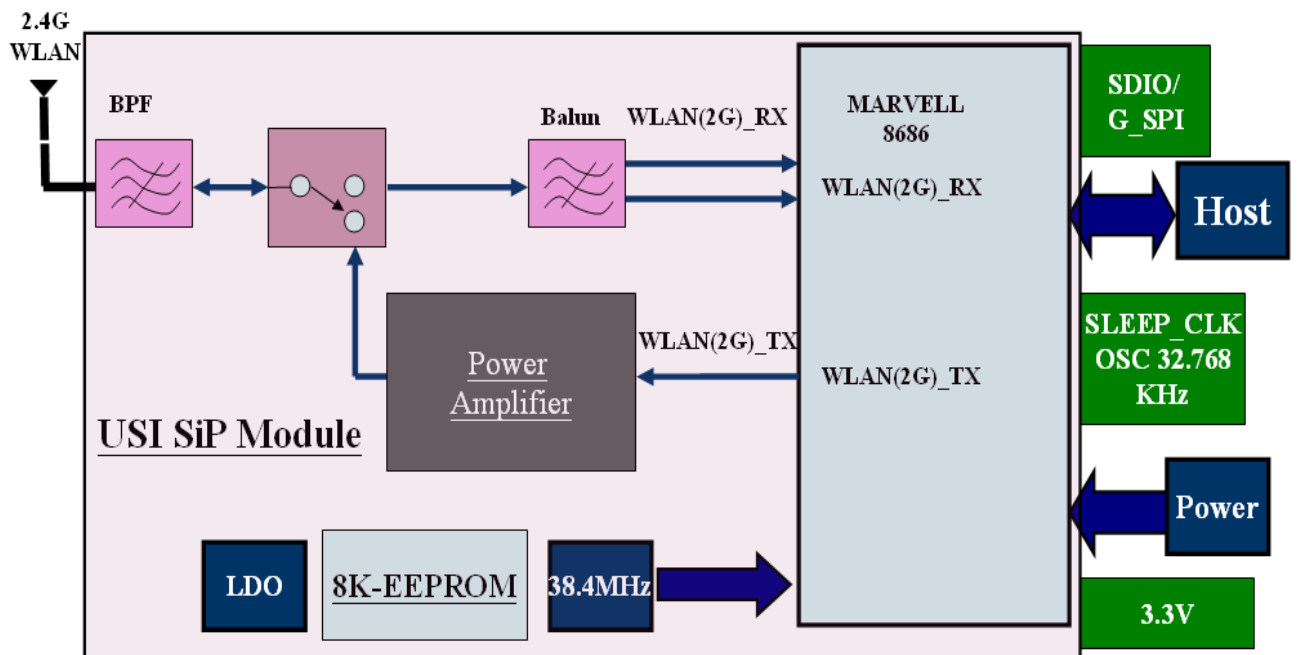

Fig. WM-G-MR-09-Ref2 Block Diagram

4 GENERAL FEATURES

	Item	Description	Notes
802.11b/g	Standard	Complies with the latest IEEE802.11b/g wireless LAN Physical Layer Specification (IEEE 802.11g dated 12/6/2003)	
	Chip Set	Marvell 88W8686	
	Module Interface Type	SDIO (1bit and 4 bit) , SDIO_SPI , G-SPI	
	Module Connection	36pin LGA	
	Co-existence	Supports 3-wire BT coexistence scheme for an external BT solution	
	Data Rate	802.11g: 54, 48, 36, 24, 18, 12, 9, 6 Mbps, auto rate 802.11b: 11, 5.5, 2, 1Mbps, auto rate	
	Modulation	OFDM (54, 48, 36, 24, 18, 12, 9, 6Mbps) CCK (11Mbps, 5.5Mbps) DQPSK (2Mbps) DBPSK (1Mbps)	
	Operating Frequency	2.4GHz ISM band	
	Operating Channels	IEEE Channels 1–11 depending on Regulatory Domain settings	
	Others	Compliance with FCC Class B Part 15.247, R&TTE, TELEC major RF regulatory requirements	

5 ELECTRICAL SPECIFICATION

5.1 SUPPLY VOLTAGE

Symbol	Parameter	Min	Typ	Max	Unit
VDD_33	TR SW, ANT SW, PA_PE	3.0	3.3	3.6	V
VDD_SHI	SDIO, G-SPI, GPIO, RESETn, PDn, SLEEP_CLK, EEPROM	1.62	1.8	1.98	V
		2.97	3.3	3.63	V
VDD_18 VDD18A	BT_STATE, WL_ACTIVE, BT_PRIORITY Analog Power Supply	1.71	1.8	1.89	V
Voltage Ripple	+/- 2%, 0~100kHz (Max. values not exceeding operating voltage)				

5.2 RECOMMENDED OPERATION CONDITIONS

5.2.1 TEMPERATURE, HUMIDITY

Symbol	Parameter	Min	Typ	Max	Unit
Ta	Ambient Operation Temperature	-10	-	65	°C
Ts	Storage Temperature	-40		85	°C
Humidity	Relative Humidity			95	%

5.2.2 DC ELECTRICAL

Symbol	Parameter	Min	Typ	Max	Units
VDD_33	Power supply voltage with respect to GND	3.0	3.3	3.6	V
VDD_SHI	Power supply voltage with respect to GND	1.62	1.8	1.98	V
		2.97	3.3	3.63	
VDD_18 VDD18A	Power supply voltage with respect to GND	1.71	1.8	1.89	V

Doc No.		Rev	1.4
Date.	2011/12/09	Page	7

5.3 POWER CONSUMPTION (SDIO MODE)

The power consumption is typical value measured at 25°C temperature

Voltage : VDD3.3

Operating Voltage	3.0~3.6 Volt
-------------------	--------------

Current

Condition	Typical (3.3V, 25 degree C)	Maximum (3.3V, 25 degree C)	Maximum (Full temperature and voltage range)
Transmit(54Mbps, 12 dBm)	270mA	300mA	400mA
Transmit(11Mbps, 14 dBm)	270mA	300mA	400mA
Receive(54Mbps, -70 dBm)	180mA	210mA	250mA
Receive(11Mbps, -70 dBm)	180mA	210mA	250mA
Deep Sleep (Use Labtool command 26 1)	0.5mA	1.0mA	1.5mA

5.4 WIRELESS SPECIFICATIONS

The WM-G-MR-09-Ref2 module complies with the following features and standards:

Features	Description
WLAN Standards	IEEE 802 Part 11b/g (802.11b/g)
Antenna Port	One antenna port support 802.11b/g
Coexistence	Hardware signaling
Frequency Band	2.4GHz ISM Band

5.5 RADIO SPECIFICATION

Over full range of values specified in the “Recommended Operation Condition” unless specified otherwise.

Features	Description
Frequency Band	2.4 GHz ISM Band
Number of selectable Sub channels	11 channels
Modulation	OFDM, DSSS (Direct Sequence Spread Spectrum), DBPSK, DQPSK, CCK , 16QAM, 64QAM
Supported rates	1, 2, 5.5, 11, 6, 9, 12, 18, 24, 36, 48, 54 Mbps
Maximum receive level	- 10dBm (with PER < 8%)
Carrier Frequency Accuracy	+/- 25ppm (crystal: 38.4MHz +/-5ppm in 25 ⁰ C)

Output Power

Data Rate	Typical (3.3V, 25 degree C)	Maximum (3.3V, 25 degree C)	Maximum (Full temperature and voltage range)
1, 2, 5.5, 11Mbps	12 dBm	12 dBm +1.0 /-2.0	12 dBm +1.0 /-2.0
6, 9 and >12Mbps	12 dBm	12 dBm +1.0 /-2.0	12 dBm +1.0 /-2.0

802.11g EVM Requirement

Item	Data Rate (Mbps)	Relative Constellation Error (dB)	EVM (%RMS)
1	6 (BPSK)	-5	56.2
2	9 (BPSK)	-8	39.8
3	12 (QPSK)	-10	31.6
4	18 (QPSK)	-13	22.4
5	24 (16-QAM)	-16	15.8
6	36 (16-QAM)	-19	11.2
7	48 (64-QAM)	-22	7.9
8	54 (64-QAM)	-25	5.6

802.11b EVM

Item	Data Rate (Mbps)	EVM (%RMS)
1	1 (BPSK)	35%
2	2 (QPSK)	35%
3	5.5 (QPSK)	35%
4	11 (QPSK)	35%

Sensitivity

Receiver Characteristics (3.3V, 25 degree C)	Typical (3.3V, 25 degree C)	Maximum (3.3V, 25 degree C)	Maximum (Full temperature and voltage range)	Unit
PER <8%, Rx Sensitivity @ 11 Mbps	-85	-83	-81	dBm
PER <8%, Rx Sensitivity @ 1 Mbps	-91	-89	-87	dBm
PER <10% Rx Sensitivity @ 6 Mbps	-86	-84	-82	dBm
PER <10%, Rx Sensitivity @ 54 Mbps	-70	-68	-66	dBm

6 INTERFACE

6.1 PIN DEFINITION

No	Pin Name	Type	Description
1	GND	GND	Ground
2	RF PORT	O	Antenna Port (50ohm)
3	GND	GND	Ground
4	NC	O	NC
5	SD_D1	I/O	SDIO 4-bit Mode: Data Line Bit [1] G-SPI Mode: G-SPI Data Output
6	SCLK	I	NC This is for Boot setting of ROM.
7	ECSn	O	Boot from SPI EEPROM: Pull down by 100kohm Boot from host Interface: NC
8	GND	GND	Ground
9	VDD_SHI	I	Host I/F Voltage: 3.3V Connect to 3.3V power supply Host I/F Voltage: 1.8V Connect to 1.8V power supply Not need to prepare external 1.8V power supply by connecting #9 and #17 (1.8V terminal)
10	GPIO_6	I/O	General I/O Port , leave open if no use.
11	GPIO_5	I/O	General I/O Port , leave open if no use.
12	SD_D3	I/O	SDIO 4-bit Mode: Data Line Bit [3]
13	GPIO_2	I/O	General I/O Port , leave open if no use.
14	SD_CLK	I/O	SDIO 4-bit Mode: Clock Input G-SPI Mode: G-SPI Clock Input
15	GPIO_4	I/O	General I/O Port , leave open if no use.
16	GPIO_1	I/O	General I/O Port t , leave open if no use. Default function : LED indicate.
17	VDD_18	POWER	1.8V DC monitor terminal , need 1uF decoupling capacitor
18	VDD_12	POWER	1.2V DC monitor terminal , need 1uF decoupling capacitor
19	GND	GND	Ground
20	SD_CMD	I/O	SDIO 4-bit Mode: Command / Response G-SPI Mode: G-SPI Data Input
21	SD_D0	I	SDIO 4-bit Mode: Data Line Bit [0] G-SPI Mode: G-SPI Chip Select Input (Active Low)
22	SD_D2	I/O	SDIO 4-bit Mode: Data Line Bit [2] G-SPI Mode: G-SPI Interrupt Output (Active Low)

Description Product Specification – WM-G-MR-09-Ref2

23	IF_SEL_1	O	Select Interface Mode Pin SDIO Mode: No Connect G-SPI Mode: Pull Down by 100kohm
24	IF_SEL_2	O	Select Interface Mode Pin SDIO Mode: No Connect G-SPI Mode: Pull Down by 100kohm
25	VDD18A	POWER	1.8V Analog DC monitor terminal , need 1uF decoupling capacitor
26	GND	GND	Ground
27	VDD_33	POWER	Connect to 3.3V DC supply
28	VDD_33	POWER	Connect to 3.3V DC supply
29	WL_ACTIVE	O	WLAN Active (Active Low) 2-Wire BCA Mode When high, WLAN is transmitting or receiving packets. 3-Wire BCA Mode 0 = Bluetooth device is allowed to transmit 1 = Bluetooth device is not allowed to transmit Internal 50kohm pull-down. This pin drives low when PDn is asserted. In WLAN Sleep mode, all I/O Pads are powered down. This Pad must stay at a low state even in power down mode. Please make it open when do not use it.
30	PDn	I	Pull up by 100kohm, Full Power Down (Active Low)
31	RESETn	I	Reset (Active Low) , leave open if no use.

Doc No.		Rev	1.4
Date.	2011/12/09	Page	11

Description Product Specification – WM-G-MR-09-Ref2

32	GPIO_0	I/O	General I/O Port , leave open if no use.
33	SLEEP_CLK	I	Clock Input for External Sleep Clock , leave open if no use.
34	PW_SEL	O	NC

6.2 SPECIFICATIONS AND TIMING DIAGRAM

6.2.1 EXTERNAL SLEEP CLOCK SPECIFICATION

The WM-G-MR-09-Ref2 external sleep clock pin (SLEEP_CLK) is powered from VDD_SHI Voltage Supply.

Protocol Timing

Symbol	Parameter	Condition	Min	Typ	Max	Units
CLK	Clock Frequency Range	--	10	100	1000	KHz
T _{HIGH}	Clock high time	--	40	--	--	ns
T _{LOW}	Clock low time	--	40	--	--	ns
T _{RISE}	Clock rise time	--	--	--	5	ns
T _{FALL}	Clock fall time	--	--	--	5	ns

NOTE: Over full range of values specified in the Recommended Operating Conditions unless otherwise specified.

6.2.2 SDIO PROTOCOL TIMING

SDIO Protocol Timing Diagram

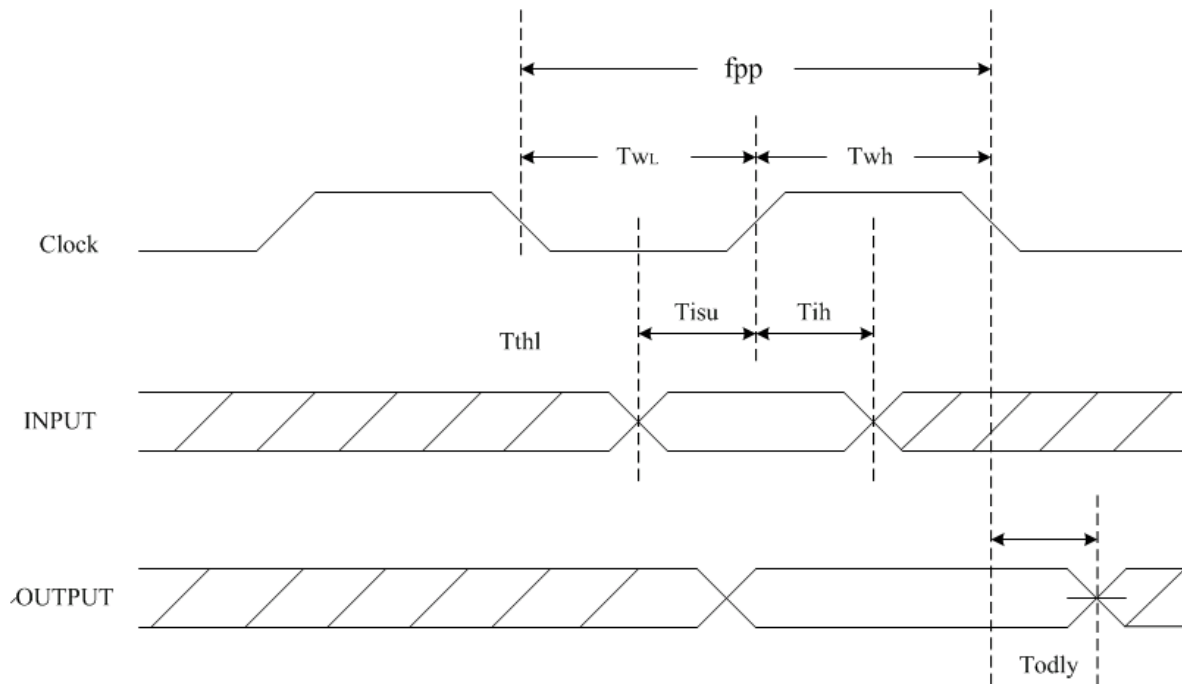

SDIO Protocol Timing Diagram – High Speed Mode

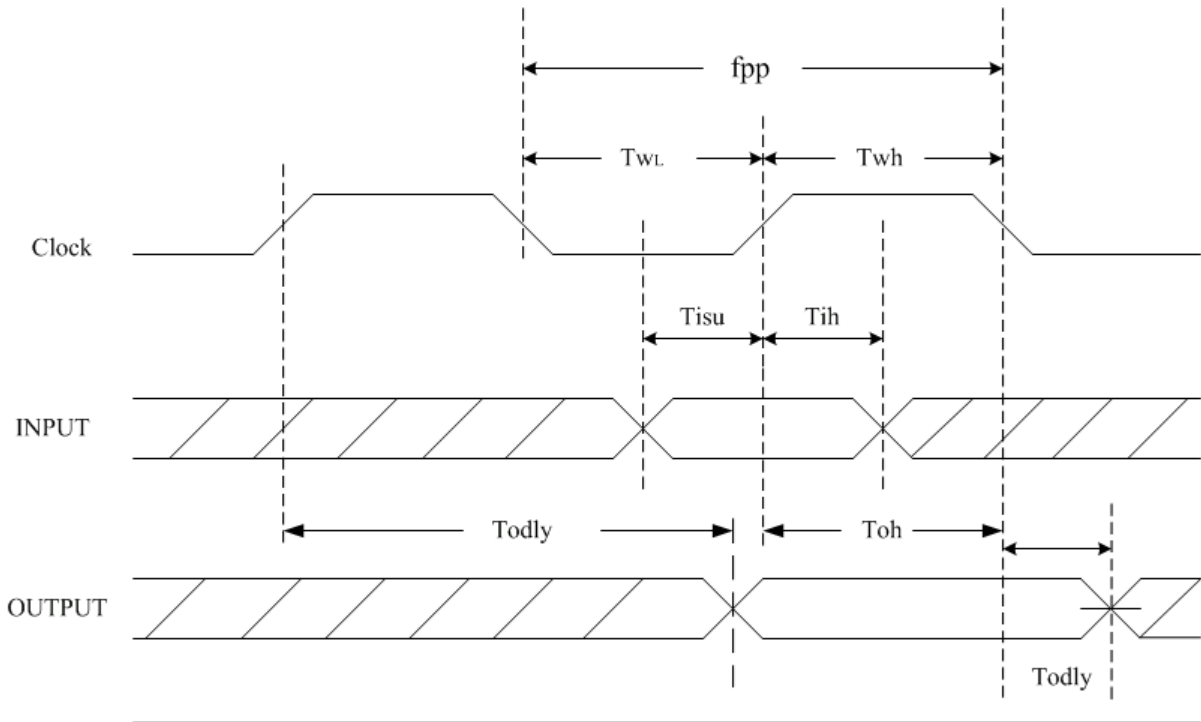

SDIO Timing Data

Symbol	Parameter	Condition	Min	Typ	Max	Units
F_{pp}	Clock Frequency	Normal	0	--	25	MHz
		High Speed	0	--	50	MHz
T_{wl}	Clock Low Time	Normal	10	--	--	ns
		High Speed	7	--	--	ns
T_{wh}	Clock High Time	Normal	10	--	--	ns
		High Speed	7	--	--	ns
T_{isu}	Input Setup Time	Normal	5	--	--	ns
		High Speed	6	--	--	
T_{ih}	Input Hold Time	Normal	5	--	--	ns
		High Speed	2	--	--	
T_{odly}	Output Delay Time	--	0	--	14	ns
T_{oh}	Output Hold Time	Normal	2.5	--	--	ns

NOTE: Over full range of values specified in the Recommended Operating Condition unless Otherwise specified.

6.2.3 G-SPI PROTOCOL TIMING

G-SPI Host Interface Transaction Timing

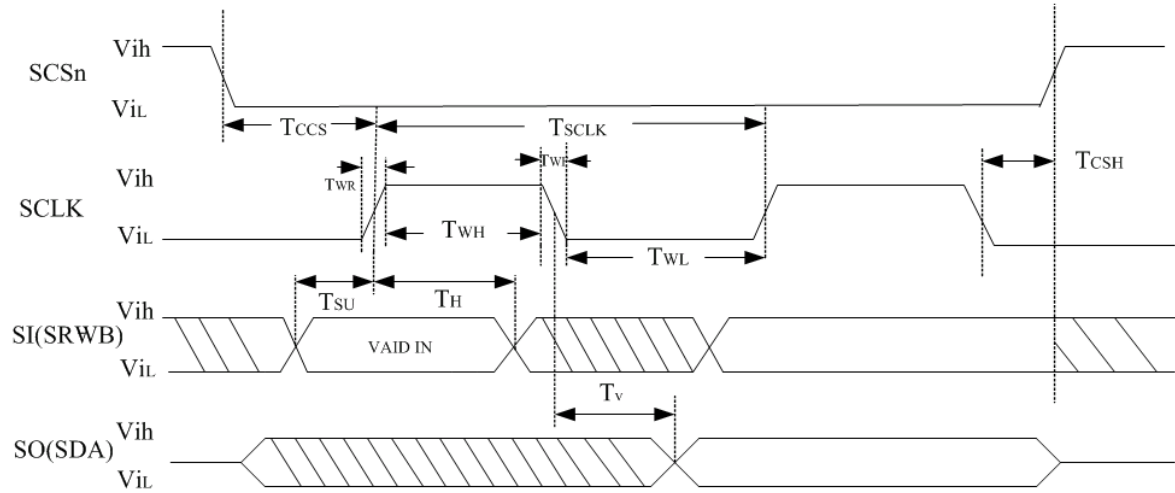

G-SPI Host Interface Inter-Transaction Timing

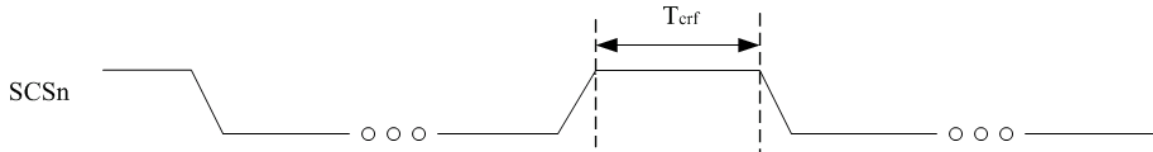

SPI Interface Timing Data

Symbol	Parameter	Min	Typ	Max	Units
T_{SCLK}	Clock Period	20	--	--	ns
T_{WH}	Clock High	5	--	--	ns
T_{WL}	Clock Low	9	--	--	ns
T_{WR}	Clock Rise Time	--	--	1	ns
T_{WF}	Clock Fall Time	--	--	1	ns
T_H	SDI Hold Time	2.5	--	--	ns
T_{SU}	SDI Setup Time	2.5	--	--	ns
T_V	SDO Hold Time	5	--	--	ns
T_{CSS}	SCSn Fall to Clock	5	--	--	ns
T_{CSH}	Clock to SCSn Rise	0	--	--	ns
T_{CRF}	SCSn Rise to SCSn Fall	400	--	--	ns

NOTE: Over full range of values specified in the Recommended Operating Condition unless Otherwise specified.

6.2.4 RESET AND CONFIGURATION TIMING

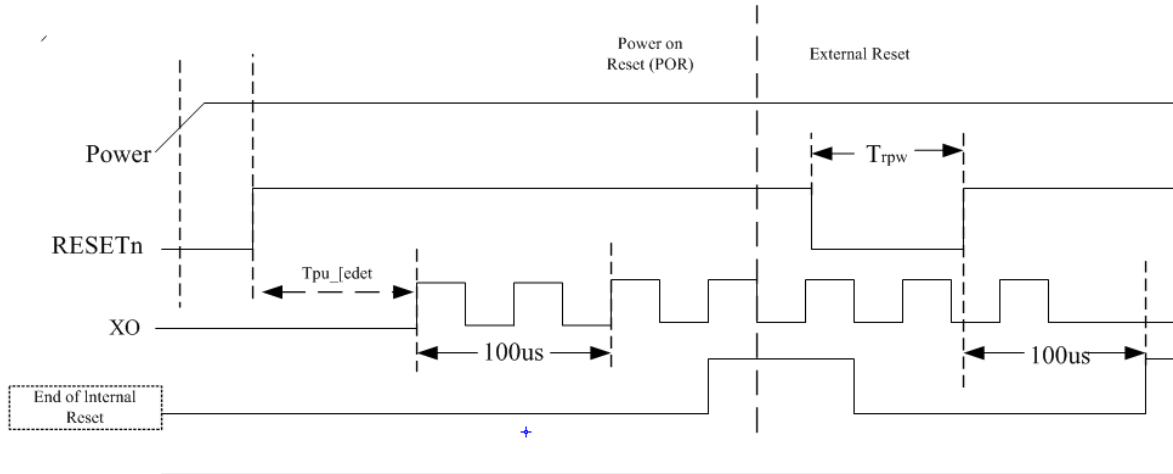

Notes

RESETn is not needed for proper operation due to internal power-on reset logic.

External Timing Requirement (RESETn Pin)

Symbol	Parameter	Condition	Min	Typ	Max	Units
T _{PU-RESET}	Valid power to RESETn de-asserted	--	0	--	--	ms
T _{RPW1}	RESETn pulse width	--	10 ²	100	--	ns

NOTE: Over full range of values specified in the Recommended Operating Conditions unless otherwise specified.

1. For external reset, the device reset time is T_{RPW} +300μs
2. Minimum value guaranteed for a valid reset smaller values may trigger the reset circuit.

Internal Reset Timing

Symbol	Parameter	Condition	Min	Typ	Max	Units
--	Negative internal reset pulse width	--	100	100	--	μ s

NOTE: Over full range of values specified in the Recommended Operating Conditions unless otherwise specified.

Doc No.		Rev	1.4
Date.	2011/12/09	Page	18

6.2.5 LED INTERFACE

Pin No.	Pin description	Function description
16	GPIO_1	WLAN status LED (Tx power or Rx ready LED)

NOTE: Over full range of values specified in the Recommended Operating Conditions unless otherwise specified.

Symbol	Parameter	Condition	Typ	Units
L _{OH}	Switching current high	Tristate on pad (requires pull-up on board)	Tristate when driving high	mA
I _{oL}	Switching current low	@0.4V	10	mA

6.2.6 ANTENNA INFORMATION

Antenna Part No. :W1030

Gain [dBi] :2.0

Trade mark: Pulse

Impedance [Nom]:50 Ω

Manufacture: A TECHNITROL COMPANY

VSWR<=2.0

Electrical Length :1/4, dipole

Radiation: Omni

Connector Options-Reverse SMA

7 REGULATORY

The WM-G-MR-09-Ref2 module is tested on module level to comply with following standards (pre-test):

- US/CAN: FCC CFR47 Part 15.247
- Europe: ETS 300-328 V1.6.1

Test setup: laptop plus adaptor card with Marvell Lab tool in SDIO mode
Final certification should be completed on system level.

9 RECOMMENDED REFLOW PROFILE

USI SiP MODULE REFLOW PROFILE

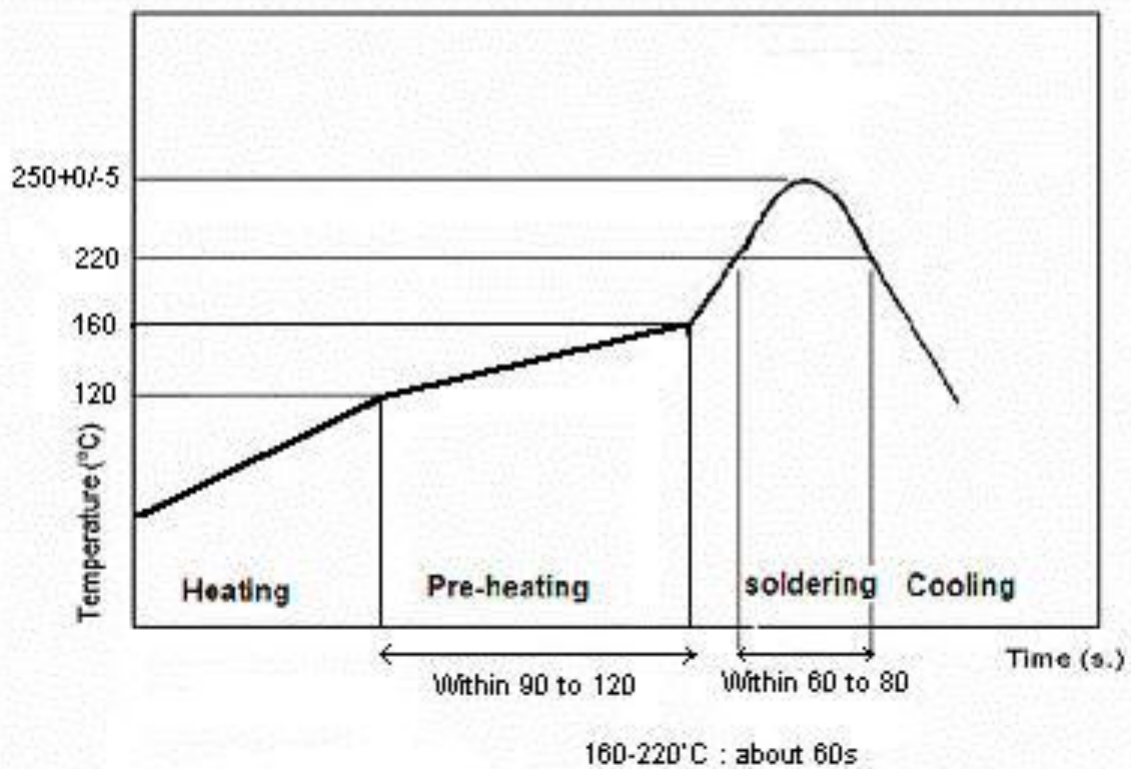

Doc No.		Rev	1.4
Date.	2011/12/09	Page	21

10 PACKAGE AND STORAGE CONDITION

10.1.1 PACKAGE DIMENSION



This device complies with part 15 of the FCC Rules. Operation is subject to the following two conditions: (1) This device may not cause harmful interference, and (2) this device must accept any interference received, including interference that may cause undesired operation. Changes or modifications not expressly approved by the party responsible for compliance could void the user's authority to operate the equipment.

FCC Radiation Exposure Statement

The modular can be installed or integrated in mobile or fix devices only. This modular cannot be installed in any portable device, for example, USB dongle like transmitters is forbidden.

This modular complies with FCC RF radiation exposure limits set forth for an uncontrolled environment. This transmitter must not be co-located or operating in conjunction with any other antenna or transmitter. This modular must be installed and operated with a minimum distance of 20 cm between the radiator and user body.

If the FCC identification number is not visible when the module is installed inside another device, then the outside of the device into which the module is installed must also display a label referring to the enclosed module. This exterior label can use wording such as the following:
"Contains Transmitter Module FCC ID: XM5-MDLWMGMR09

when the module is installed inside another device, the user manual of this device must contain below warning statements;

1. This device complies with Part 15 of the FCC Rules. Operation is subject to the following two conditions:
 - (1) This device may not cause harmful interference.
 - (2) This device must accept any interference received, including interference that may cause undesired operation.
2. Changes or modifications not expressly approved by the party responsible for compliance could void the user's authority to operate the equipment.

The devices must be installed and used in strict accordance with the manufacturer's instructions as describe

#