

# Nano WiReach™ SMT

## Nano WiReach™ SMT



# Data Sheet

Ver. 1.40

---

**Connect**  **one™**

International:

Connect One Ltd.

20 Atir Yeda Street

Kfar Saba 44643, Israel

Phone: +972-9-766-0456

Fax: +972-9-766-0461

Email: [sales@connectone.com](mailto:sales@connectone.com)

[www.connectone.com](http://www.connectone.com)

Information provided by Connect One Ltd. is believed to be accurate and reliable. However, Connect One assumes no responsibility for its use, nor any infringement of patents or other rights of third parties, which may result from its use. No license is granted by implication or otherwise under any patent rights of Connect One other than for circuitry embodied in Connect One's products. Connect One reserves the right to change circuitry at any time without notice. This document is subject to change without notice.

The software described in this document is furnished under a license agreement and may be used or copied only in accordance with the terms of such a license agreement. It is forbidden by law to copy the software on any medium except as specifically allowed in the license agreement. No part of this document may be reproduced or transmitted in any form or by any means, electronic or mechanical, including but not limited to photocopying, recording, transmitting via fax and/or modem devices, scanning, and/or information storage and retrieval systems for any purpose without the express written consent of Connect One.

**WARNING:** THE Nano WiReach SMT IS AN RF MODULE INTENDED FOR EMBEDDING IN A HOST DEVICE. LOCAL RELEVANT RF REGULATIONS SUCH AS ALLOWED FREQUENCIES AND USAGE IN COMMERCIAL FLIGHTS MUST BE OBSERVED. SAFETY INSTRUCTIONS MUST BE INCLUDED IN THE MANUALS OF THE HOST DEVICE. CONNECT ONE ASSUMES NO LIABILITY FOR CUSTOMER FAILURE TO COMPLY WITH THESE PRECAUTIONS.

#### **Modifications**

The FCC requires the user to be notified that any changes or modifications made to this device that are not expressly approved by Option could void the user's authority to operate the equipment.

#### **This device complies with Part 15 of the FCC rules.**

This device complies with Part 15 of the FCC rules. Operation is subject to the following two conditions:

- (1) this device may not cause harmful interference, and
- (2) this device must accept any interference received, including interference that may cause undesired operation.

#### **Exposure Information to Radio Frequency Energy**

This equipment complies with FCC radiation exposure limits set forth for an uncontrolled environment. This equipment should be installed and operated with minimum distance of 20 cm between the radiator and your body.

This transmitter must not be co-located or operating in conjunction with any other antenna or transmitter.

*" Under Industry Canada regulations, this radio transmitter may only operate using an antenna of a type and maximum (or lesser) gain approved for the transmitter by Industry Canada. To reduce potential radio interference to other users, the antenna type and its gain should be so chosen that the equivalent isotropically radiated power (e.i.r.p.) is not more than that necessary for successful communication."*

*" Conformément à la réglementation d'Industrie Canada, le présent émetteur radio peut fonctionner avec une antenne d'un type et d'un gain maximal (ou inférieur) approuvé pour l'émetteur par Industrie Canada. Dans le but de réduire les risques de brouillage radioélectrique à l'intention des autres utilisateurs, il faut choisir le type d'antenne et son gain de sorte que la puissance isotrope rayonnée équivalente (p.i.r.e.) ne dépasse pas l'intensité nécessaire à l'établissement d'une communication satisfaisante."*

*" This radio transmitter (SM2144N2-BIO) has been approved by Industry Canada to operate with the antenna types listed below with the maximum permissible gain and required antenna impedance for each antenna type indicated. Antenna types not included in this list, having a gain greater than the maximum gain indicated for that type, are strictly prohibited for use with this device."*

*" Le présent émetteur radio (SM2144N2-BIO) a été approuvé par Industrie Canada pour fonctionner avec les types d'antenne énumérés ci-dessous et ayant un gain admissible maximal et l'impédance requise pour chaque type d'antenne. Les types d'antenne non inclus dans cette liste, ou dont le gain est supérieur au gain maximal indiqué, sont strictement interdits pour l'exploitation de l'émetteur."*

*" This device complies with Industry Canada license-exempt RSS standard(s). Operation is subject to the following two conditions: (1) this device may not cause interference, and (2) this device must accept any interference, including interference that may cause undesired operation of the device."*

*" Le présent appareil est conforme aux CNR d'Industrie Canada applicables aux appareils radio exempts de licence. L'exploitation est autorisée aux deux conditions suivantes : (1) l'appareil ne doit pas produire de brouillage, et (2) l'utilisateur de l'appareil doit accepter tout brouillage radioélectrique subi, même si le brouillage est susceptible d'en compromettre le fonctionnement."*

*Antennas: Air Wave (EA-79F); Tekfun C. (M04-SR); YC Communication (Q24-24W); Pulse (W1030). Maximum Gain all: 2dBi.*

iChip, Nano WiReach SMT, IP Communication Controller, SerialNET, AT+i and Connect One are trademarks of Connect One Ltd.

Copyright © 2011 Connect One Ltd. All rights reserved.

## Revision History

### 11-4500-05

Version	Date	Description
1.00	February 2011	Initial preliminary version
1.10	April 2011	Fixed Pinout table
1.20	April 2011	Updated Definitions
1.30	April 2011	Misc. Editing
1.35	May 2011	Updated Temperature Range
1.40	June 2011	Added FCC and Regulatory Notices

# Contents

<b>1</b>	<b>Introduction.....</b>	<b>1-1</b>
1.1	General Description .....	1-1
1.2	Hardware Description.....	1-1
1.3	Performance Specifications .....	1-1
<b>2</b>	<b>Features.....</b>	<b>2-1</b>
2.1	Security .....	2-1
2.2	Protocols .....	2-1
2.3	Additional Features .....	2-1
<b>3</b>	<b>Typical Applications .....</b>	<b>3-1</b>
<b>4</b>	<b>Connector Pin Description .....</b>	<b>4-1</b>
4.1	Pin Numbers.....	4-1
<b>5</b>	<b>Interfaces.....</b>	<b>5-1</b>
5.1	Serial Interface .....	5-1
5.2	SPI Interface.....	5-1
5.3	USB 1.1 Device Interface.....	5-1
5.4	RMII Interface.....	5-2
5.5	USB 1.1 Host Interface .....	5-2
<b>6</b>	<b>Electrical Specifications .....</b>	<b>6-1</b>
6.1	Absolute Maximum Ratings .....	6-1
6.2	DC Operating Characteristics .....	6-1
6.3	AC Operating Characteristics.....	6-2
6.4	Tx Specifications .....	6-2
6.5	Rx Specifications.....	6-2
<b>7</b>	<b>On-Board Antenna .....</b>	<b>7-3</b>
<b>8</b>	<b>Mechanical Dimensions.....</b>	<b>8-1</b>
8.1	Antenna Clearance Recommendation .....	8-2

**9 Recommended PCB Footprint ..... 9-1**

**10 Evaluation Board ..... 10-1**

**11 Ordering Information ..... 11-1**

**12 Internet Protocol Compliance ..... 12-1**

# Figures

Figure 3-4-1: Pin-out for Nano WiReach SMT(Bottom view).....4-1

Figure 6-1: SPI Interface Waveforms .....6-2

Figure 5-8-1: Mechanical Dimensions .....8-1

Figure 5-9-1: Recommended PCB Footprint .....9-1

## Tables

Table 3-1: Connector Signal Description .....	4-2
Table 4-1: Absolute Maximum Ratings .....	6-1
Table 4-2: DC Operating Characteristics .....	6-1
Table 4-3: Tx Specifications .....	6-2
Table 4-4: Rx Specifications .....	6-2
Table 12-1: Internet Protocol Compliance .....	12-1

# 1 Introduction

## 1.1 General Description

Nano WiReach™ SMT is a secure serial-to-Wireless-LAN device server module that also acts as a bridge to connect serial devices to 802.11b/g Wireless LANs. It includes the iChip™ CO2144 IP Communication Controller™ chip and Marvell 88W8686 WiFi chipset. It is packaged in RoHS-compliant ultra-slim form factor and uses an industry standard pin-out. The Nano WiReach SMT can also be interfaced to a 10/100BaseT wired LAN and a USB cellular modem with some external components and glue logic.

Nano WiReach SMT offers much more than many other device servers on the market. It acts as a security gap between the application and the network; supports up to 10 simultaneous TCP/UDP sockets; two listening sockets; a web server with two websites; SMTP and POP3 clients; MIME attachments; FTP and TELNET clients, and SerialNET™ mode for serial-to-IP bridging.

Nano WiReach SMT supports the SSL3/TLS1 protocol for secure sockets, HTTPS and FTPS, WEP, WPA and WPA2 WiFi encryption.

Nano WiReach SMT minimizes the need to redesign the host device hardware. It features a standard economical SMT footprint providing for low-cost placement on a host PCB with provisions for an on-board or external antenna. Minimal or no software configuration is needed for Nano WiReach SMT to access the Wireless LAN.

Connect One's high-level AT+i™ API eliminates the need to add WiFi drivers, security and networking protocols and tasks to the host application. The AT+i SerialNET operating mode offers a true plug-and-play mode that eliminates any changes to the host application.

Nano WiReach SMT firmware – the IP stack and Internet configuration parameters – are stored in an external flash memory. The module is power-efficient: the core operates at 1.2V, while I/Os operate at 3.3V. Power Save mode further reduces power consumption.

The II-EVB-365SMT evaluation board provides an easy environment for testing the Nano WiReach SMT prior to designing it into your product.

## 1.2 Hardware Description

Size: 37.0 x 20.0 x 2.5 mm

Core CPU: 32-bit RISC ARM7TDMI, low-leakage, 0.13 micron, running at 48MHz

Operating Voltage: +3.3V±10%

Operating Humidity: 90% maximum (non-condensing)

Operating Temperature Range: -10° to 65°C (14° to 149°F)

Power Consumption:  
Transmit – 250mA @16dbm  
235mA @12dbm (typical)  
Receive – 190mA (typical)  
Power Save mode – 8mA

Optional : On-Board antenna

Optional: U.FL connector

Connection: 44 SMT pads

Host Interface: TTL Serial, SPI and USB 1.1 device.

A/D Input (see AT+i programmers manual)

Cellular Modem Interface: USB 1.1 Host

10/100BaseT LAN Interface: RMII (w/ext. PHY)

RoHS-compliant; lead-free

## 1.3 Performance Specifications

Host Data Rate: up to 3Mbps in serial mode

Serial Data Format (AT+i mode):

Asynchronous character; binary; 8 data bits; no parity; 1 stop bit

SerialNET mode: Asynchronous character; binary; 7 or 8 data bits; odd, even, or no parity; 1 stop bit

Flow Control: Hardware (-RTS, -CTS) and software flow control.



**Internet Protocols**

ARP, ICMP, IP, UDP, TCP, DHCP, DNS, NTP, SMTP, POP3, MIME, HTTP, FTP and TELNET

**Security Protocols**

SSL3/TLS1, HTTPS, FTPS, RSA, AES-128/256, 3DES, RC-4, SHA-1, MD-5, WEP, WPA and WPA2

**Protocols Accelerated in HW**

AES, 3DES and SHA

**Application Program Interface**

Connect One's AT+i protocol

SerialNET mode for transparent serial data-to-Internet bridging

**Wireless Specifications**

Standards Supported: IEEE 802.11b, IEEE 802.11g

- Frequency:
  - Europe – 2.412-2.472GHz
  - USA – 2.412-2.462GHz
  - Japan – 2.412–2.484GHz
- Channels:
  - Europe – 13 channels
  - USA – 11 channels
  - Japan – 14 channels

**Recommended Antenna (for U.FL option)**

iW-ANT2-BL Antenna: 2.4GHz, 2.0dBi, 50Ω, omni-directional, 1/4 wavelength dipole configuration, VSWR≤2.0, height - 82.5mm, weight – 6.3 grams

**Warranty**

One year

Certifications:

- **Radio & EMC:**
  - **USA**
    - o **FCC Modular Approval**
    - o **CFR Title 47 FCC Part 15, Subpart B and C**
  - **Canada**
    - o **Industry Canada Module Approval**
    - o **Industry Canada ICES-003, RSS-Gen, RSS-210**
  - **EU**
    - o **EN 300 328 (R&TTE Directive 1999/5/EC)**
    - o **EN 301 489 (EMC Directive 2004/108/EC)**
- **Safety:**
  - o **UL 60950**
  - o **CAN/CSA-C22.2 No. 60950**
  - o **EN 60950, Low Voltage Directive (2006/95/EC)**

THIS DEVICE COMPLIES WITH PART 15 OF THE FCC RULES. OPERATION IS SUBJECT TO THE FOLLOWING TWO CONDITIONS: (1) THIS DEVICE MAY NOT CAUSE HARMFUL INTERFERENCE, AND (2) THIS DEVICE MUST ACCEPT ANY INTERFERENCE RECEIVED, INCLUDING INTERFERENCE THAT MAY CAUSE UNDESIRE OPERATION. (\*)

**Installation Requirements**

The Nano WiReach SMT must be installed within a full-enclosure device that is safety certified.

(\*) NOTE: THE MANUFACTURER IS NOT RESPONSIBLE FOR ANY RADIO OR TV INTERFERENCE CAUSED BY UNAUTHORIZED MODIFICATIONS TO THIS EQUIPMENT. SUCH MODIFICATIONS COULD VOID THE USER'S AUTHORITY TO OPERATE THE EQUIPMENT

## 2 Features

### 2.1 Security

- Acts as a security gap between the host application and the network
- One secure SSL3/TLS1 socket
- Provides WEP, WPA and WPA2 Wireless LAN security
- Supports multiple Certificate Authorities and both client-side and server-side authentication
- Secure FTP and HTTP clients (over SSL3)
- Includes a true hardware random number generator
- AES, 3DES and SHA accelerated in hardware

### 2.2 Protocols

- Up to 10 simultaneous TCP/UDP sockets and two listening sockets
- HTTP client
- HTTP web server with two on-chip websites: configuration site and application site
- FTP and TELNET clients
- DHCP client and server
- Sending and receiving textual email and binary email with MIME attachments

### 2.3 Additional Features

- Non-volatile, on-chip operational parameter database
- Supports infrastructure and ad-hoc Wireless LAN networks
- SerialNET mode for serial-to-IP bridging (port server mode)
- Local firmware update
- Remote configuration and firmware update over the Internet
- Retrieval of time data from a Network Time Server

**Note:** For a detailed description of all available features, see the *AT+i Programmer's Manual*.

### 3 Typical Applications

Adding IP communications over WiFi to serial embedded devices.

Replacing a LAN cable with a WiFi connection.

Adding SSL security to M2M solutions.

#### **Nano WiReach SMT supports several operational modes:**

- **LAN to WiFi Bridge** - allowing transparent bridging of LAN over WiFi, using direct RMII connection to existing MAC hardware or direct PHY-to-PHY connection.

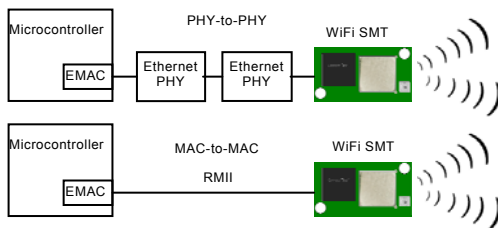

- **SerialNet™ Serial to WiFi Bridge** - allowing transparent bridging of Serial over WiFi, using a 3Mbps fast UART. This is a true plug-and-play mode that eliminates any changes to the host application.
- **PPP modem emulation** – allowing existing (i.e. modem) designs currently using PPP to connect transparently over WiFi.
- **Full Internet Controller mode** – allowing simple MCU to use the Nano WiReach SMT's rich protocol and application capabilities to perform complex Internet operations such as E-mail, FTP, SSL, embedded Web server and others. It also acts as a firewall, providing a security gap between the application and the network.
- **LAN/WiFi ⇔ Cellular Router** – allowing local systems, communicating over LAN and/or WiFi, to gain WAN access to the Internet via a cellular modem. This mode includes a DHCP server and NAT to support multiple local systems communicating over a single cellular link.

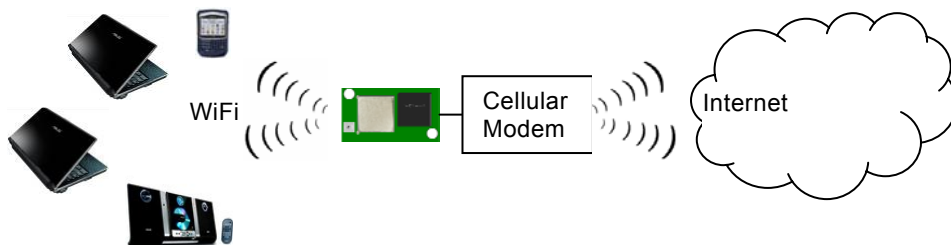

## 4 Connector Pin Description

The Nano WiReach SMT module includes the iChip CO2144 IP Communication Controller and the Marvell 88W8686 802.11b/g WiFi chipset mounted on a socket form-factor module.

### 4.1 Pin Numbers

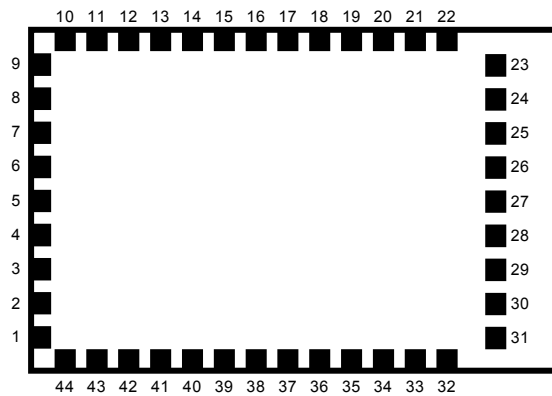

Figure 3-4-1: Pin-out for Nano WiReach SMT(Bottom view)

## Pin Functional Description

Pin	Signal	type	Description
1	GND	Power	
2	HDM	Analog	USB Host negative
3	HDP	Analog	USB Host positive
4	nRESET	Input	Reset Module. Pull LOW for 100mSec to Reset
5	PIOC4	I/O	General In/Output Port
6	MSEL	Input	Mode select. Used for inducing rescue mode and forced local Firmware-update.
7	DATA_RDY	Output	Data ready. Signals incoming Internet data.
8	ETX_EN	Output	RMII Transmit Enable
9	REFCLK	Input	RMII Reference Clock 50Mhz
10	ETX0	Output	RMII transmit Data 0
11	ETX1	Output	RMII transmit Data 1
12	CRSDV	Input	RMII Carrier sense and Data Valid
13	ERX0	Input	RMII Receive Data 0
14	ERX1	Input	RMII Receive Data 1
15	ERXER	Input	RMII Receive Error
16	EMDC	Output	Management data Clock
17	EMDIO	I/O	Management data I/O
18	PIOC5	I/O	General In/Output Port
19	VBUS	Output	VBUS for USB Host
20	Readiness	Output	iChip Ready status line. See AT+I programmers manual.
21	PIOC3	I/O	General In/Output Port
22	VDD	Power	3.3V
23-31	GND	Power	
32	nRF_LED	Output	RF LED indicator
33	ACH	Input	Analog Input
34	SPI1_CLK	Input	SPI 1 clock for host (Max 12MHz)
35	nSPI1_CS	Input	SPI 1 chip select for host
36	SPI1_MISO	Output	SPI 1 slave out for host master in
37	SPI1_MOSI	Input	SPI 1 slave in for host master out
38	SPI1_INT	Output	SPI 1 have data on his buffer
39	TXD0	Output	UART 0 transmit
40	RXD0	Input	UART 0 receive
41	nCTS0	Input	UART 0 clear to send
42	nRTS0	Output	UART 0 request to send
43	DDM	Analog	USB device negative
44	DDP	Analog	USB device positive

Table 3-1: Connector Signal Description

## 5 Interfaces

### 5.1 Serial Interface

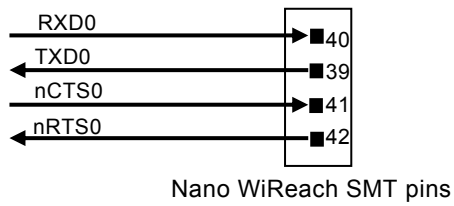

### 5.2 SPI Interface

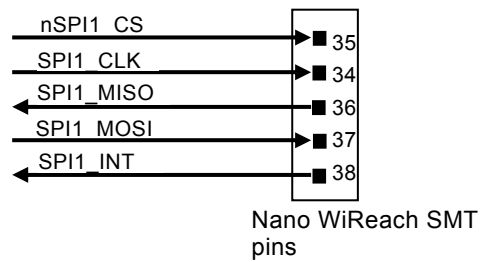

### 5.3 USB 1.1 Device Interface

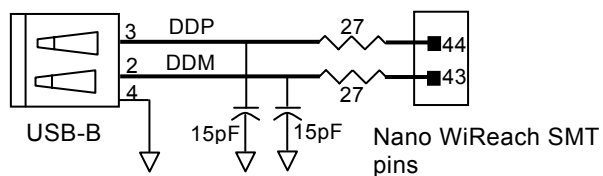

## 5.4 RMII Interface

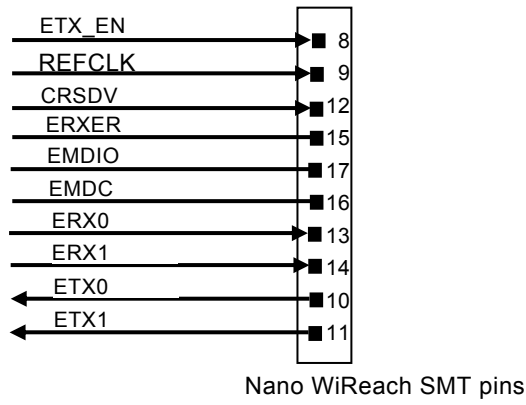

## 5.5 USB 1.1 Host Interface

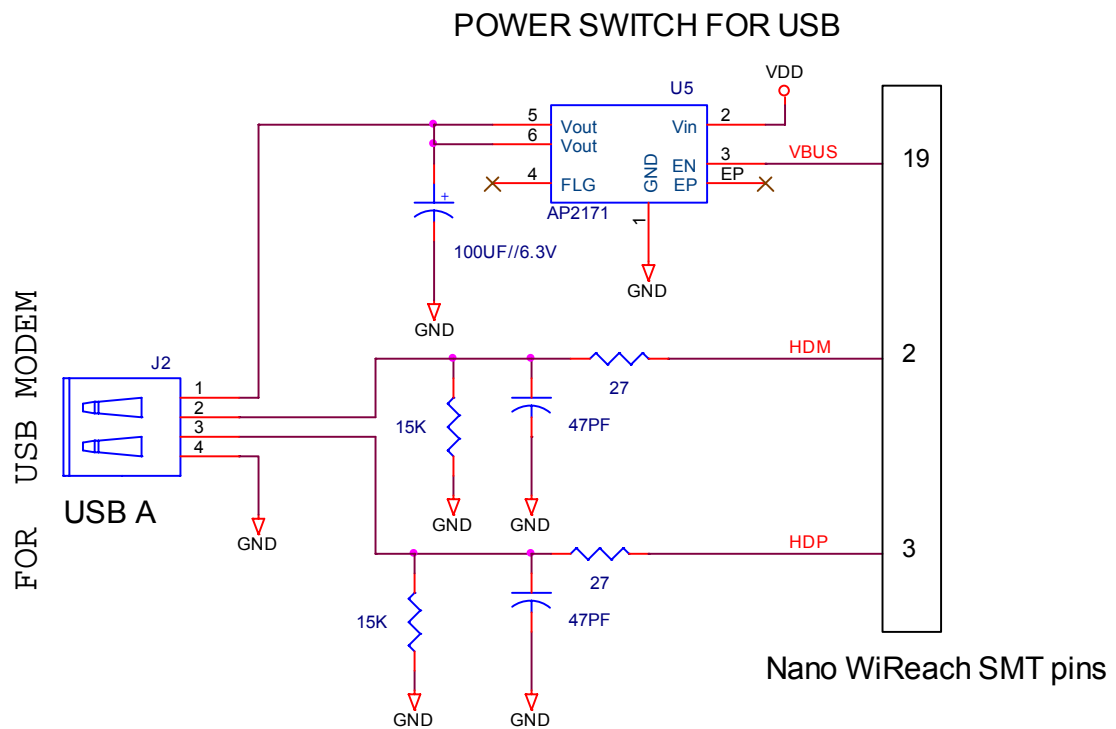

## 6 Electrical Specifications

### 6.1 Absolute Maximum Ratings

Parameter	Rating
Voltage at any pin with respect to ground	-0.3V to +3.6V
Operating temperature	-10°C to 65°C (14°F to 149°F)
Storage temperature	-65°C to 125°C (-85°F to 257°F)

Table 4-1: Absolute Maximum Ratings

### 6.2 DC Operating Characteristics

Parameter	Min	Typical	Max	Units
VDD	3.0	3.3	3.6	Volts
High-level Input	2.0		VDD I/O+0.3	Volts
Low-level Input	-0.3		0.8	Volts
High-level Output @2mA	VDD I/O-0.4			Volts
High-level Output @0mA	VDD I/O-0.2			Volts
Low-level Output @2mA			0.4	Volts
Low-level Output @0mA			0.2	Volts
Input leakage current			10	µA
Power supply current from VDD (Transmit Mode)		260	280	mA
Power supply current from VDD (Receive Mode)		190	210	mA
Power supply current from VDD (Power Save Mode)		8*		mA
Input Capacitance			5.3	pF
Radio Frequency Range (subject to local regulation)	2.412		2.484	GHz

Table 4-2: DC Operating Characteristics

(\*) **Note:** Power supply current as measured in firmware version i2128d722B05.



## 6.3 AC Operating Characteristics

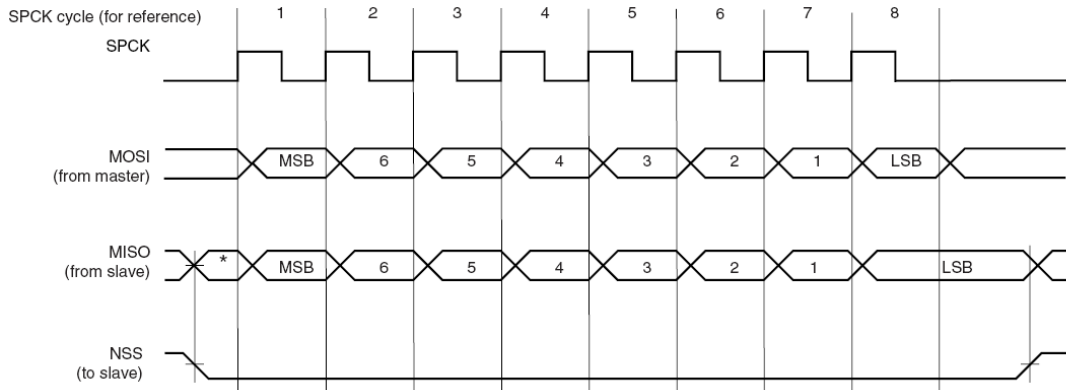

Figure 6-1: SPI Interface Waveforms

## 6.4 Tx Specifications

Item	Condition	Min	Typ	Max	Unit
Transmit Power Levels	11b		15		dBm
	11g		15		dBm
Transmit Spectrum Mask	11b	Fc+/-11MHz	40		dBc
		Fc+/-22MHz	60		dBc
	11g	Fc+/-11MHz	30		dBc
		Fc+/-20MHz	40		dBc
		Fc+/-30MHz	50		dBc
Transmit Center Frequency Tolerance	Temperature=25°C		±10		ppm

Table 4-3: Tx Specifications

## 6.5 Rx Specifications

Item	Condition	Min	Typ	Max	Unit
Receiver Minimum Input Level Sensitivity	802.11b Data Rate=11Mbps, PER<8%		-88		dBm
	802.11g Data Rate=54Mbps, PER<10%		-74		dBm
Adjacent Channel Rejection Desired channel is 3dB above sensitivity	802.11b Data Rate=11Mbps, PER<8%		48		dBc
	802.11g Data Rate=54Mbps, PER<10%		15		dBc

Table 4-4: Rx Specifications

$$PER(\%) = (\text{Number of all packets} - \text{Number of received packets}) / (\text{Number of all packets} \times 100)$$

## 7 On-Board Antenna

Designed for 2.4Ghz operation

Peak Gain: 2.1 dBi

Average efficiency: 75%

Max return loss: -11dBi

Max VSWR: 1.8:1

Antenna Patterns:

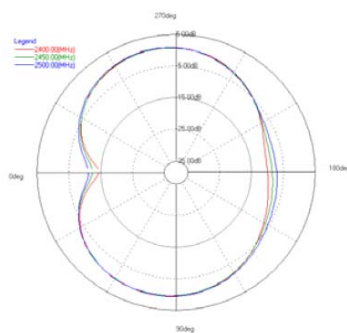

XY plane

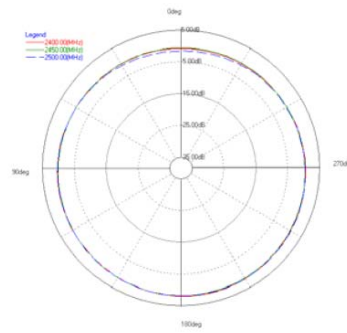

ZY plane

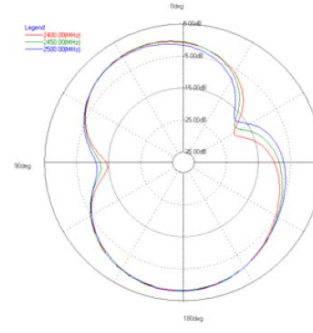

XZ plane

## 8 Mechanical Dimensions

### UPPER VIEW

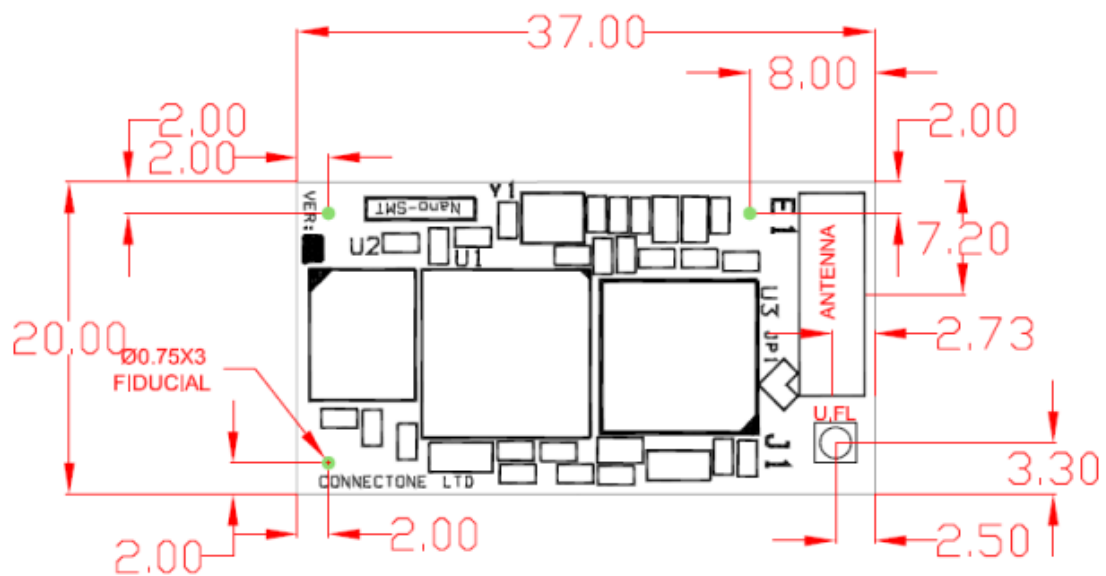

### BOTTOM VIEW

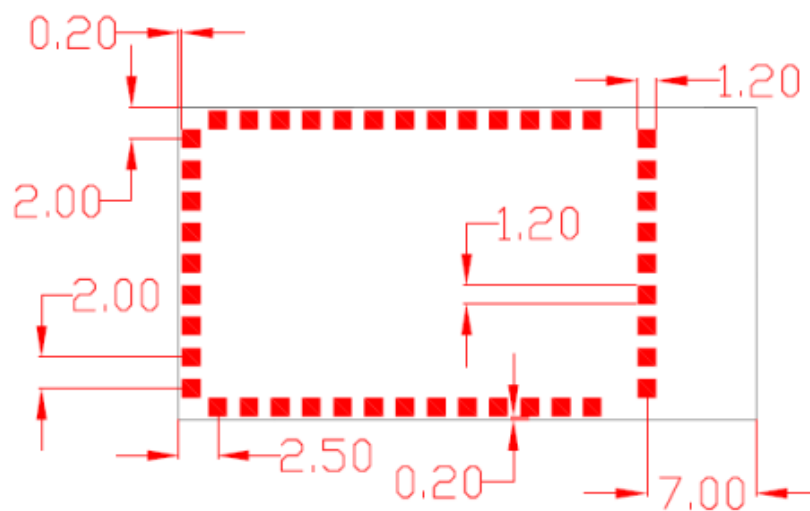

Note: All measures are in millimeters +/- 0.2 mm

Figure 5-8-1: Mechanical Dimensions

## 8.1 Antenna Clearance Recommendation

The striped area below should be clear of metal, ground planes and wiring:

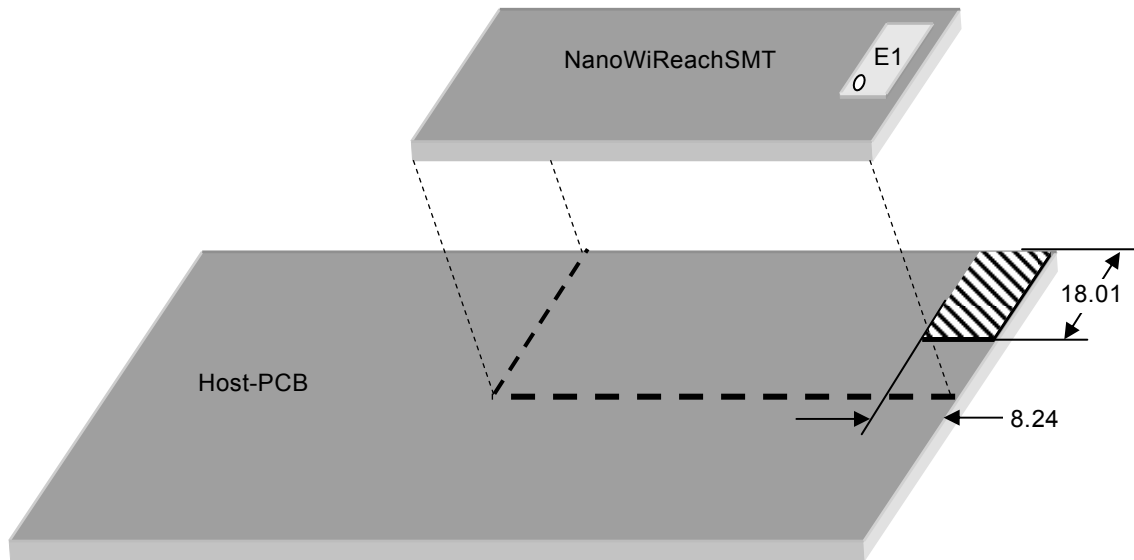

Figure 5-8-2: Antenna Clearance

## 9 Recommended PCB Footprint

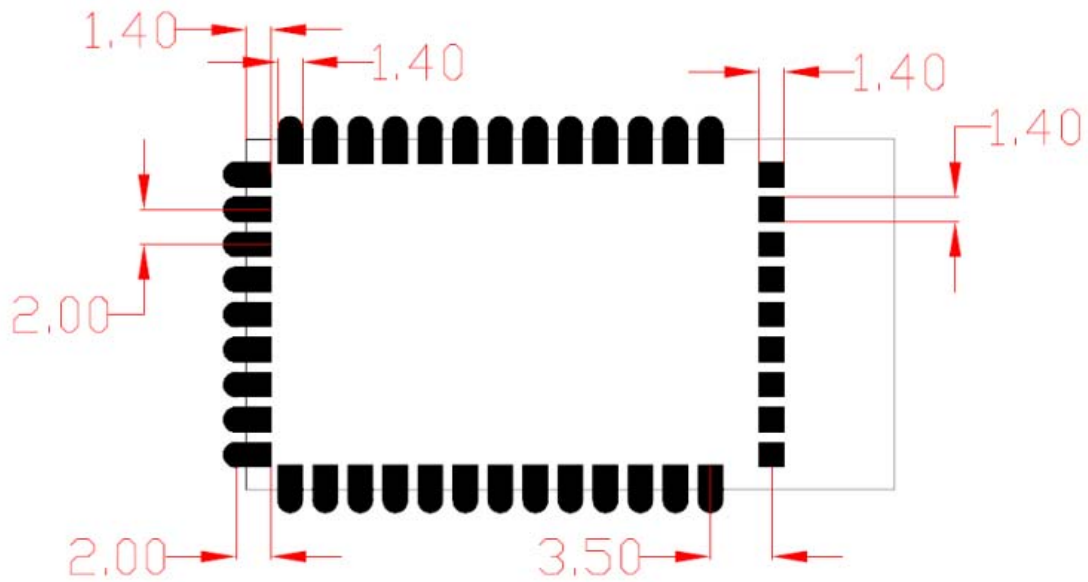

Figure 5-9-1: Recommended PCB Footprint

## 10 Evaluation Board

The II-EVB-365smt evaluation board enables you to evaluate the Nano WiReach SMT without changing anything in your current development environment. Using a simple Windows-based application on a PC, you can issue AT+i commands to the iChip CO2144 and get responses.

**Note:** *The evaluation board supports serial host data rates of up to 1Mbps.*

---

AT+i commands are used to configure parameter values into iChip's flash memory and activate Internet tasks such as email send, sockets, FTP sessions, configuration, and more.

A full description of AT+i commands can be found in the *AT+i Programmer's Manual* on Connect One's website at: <http://www.connectone.com/support.asp?did=35>

To help you evaluate the Nano WiReach SMT, Connect One supplies the iChip Config Utility. This is a Windows-based application that contains intuitive dialog boxes to fully configure iChip CO2144. It doesn't require any knowledge of AT+i commands. It also contains local firmware update functionality. The iChip Config Utility allows you to perform specific Internet communication tasks such as sending and receiving emails, activating iChip's websites, entering SerialNET mode, and more. The latest iChip Config Utility version and user manual can be found on Connect One's website under the Support section.

On board connectors allow a choice of Host interfaces:

- RS232 COM port
- SPI
- USB Device

# 11 Ordering Information

Ordering Information	
Part Number	Description
iW- SM2144SMT-EX	Nano WiReach SMT module, External Antenna
iW- SM2144SMT-OB	Nano WiReach SMT module, On-board Antenna
II-EVB-365SMT	Evaluation board for Nano WiReach SMT module, On-board Antenna
iW-CAB-150	Miniature coaxial w/ pigtail cable. UFL-SMA connectors. 150mm length.
iW-ANT2-BL	2.4GHz WiFi antenna, 2.0dBi, 50Ω, omni-directional, 1/4 wavelength dipole configuration

# 12 Internet Protocol Compliance

Nano WiReach SMT complies with the Internet standards listed in the following table.

<b>RFC 768</b>	User datagram protocol (UDP)
<b>RFC 791</b>	Internet protocol (IP)
<b>RFC 792</b>	ICMP – Internet control message protocol
<b>RFC 793</b>	Transmission control protocol (TCP)
<b>RFC 821</b>	Simple mail transfer protocol (SMTP)
<b>RFC 822</b>	Standard for the format of ARPA Internet text messages
<b>RFC 826</b>	Ethernet address resolution protocol (ARP)
<b>RFC 959</b>	File transfer protocol (FTP)
<b>RFC 854</b>	TELNET protocol specification
<b>RFC 857</b>	Telnet ECHO option
<b>RFC 858</b>	Telnet suppress go-ahead option
<b>RFC 1034</b>	Domain names (DNS) - concepts and facilities
<b>RFC 1035</b>	Domain names (DNS) - implementation and specification
<b>RFC 1073</b>	Telnet window size option
<b>RFC 1091</b>	Telnet terminal type option
<b>RFC 1321</b>	MD5 message digest algorithm
<b>RFC 1939</b>	Post office protocol - version 3 (POP3)
<b>RFC 1957</b>	Some observations on the implementations of the post office protocol (POP3)
<b>RFC 2030</b>	Simple network time protocol (SNTP)
<b>RFC 2045</b>	Multipurpose Internet mail extensions (MIME) part one: internet message body format
<b>RFC 2046</b>	MIME part two: media types
<b>RFC 2047</b>	MIME part three: message header extensions for non-ASCII text
<b>RFC 2048</b>	MIME part four: registration procedures
<b>RFC 2049</b>	MIME part five: conformance criteria and examples
<b>RFC 2068</b>	Hypertext transfer protocol HTTP/1.1
<b>RFC 2131</b>	Dynamic host configuration protocol (DHCP)
<b>RFC 2132</b>	DHCP options (only relevant parts)
<b>RFC 2228</b>	FTP security extensions
<b>RFC 2246</b>	The TLS protocol version 1.0

*Table 12-1: Internet Protocol Compliance*