

[www.tuv.com](http://www.tuv.com)

## 1.6 User Manual

### SUMMARY

7

Introduction

11

Using your Dior Bluetooth® headset

15

Warranty & Regulation

5

## INTRODUCTION

Thank you for purchasing the Dior Bluetooth® headset.

You are now the privileged owner of the ultimate luxury  
Dior Bluetooth® headset.

Our design team drew each element with the same passion,  
creativity and expertise as for couture pieces.

We have also selected the best materials  
to emphasize the excellence and know how of Dior.

The Dior Bluetooth® headset is a wireless headset based on the  
Bluetooth® technology. It complies with Bluetooth® 2.0 protocol,  
supporting headset and hands-free profile.

The headset has only one button: the "TALK" button.

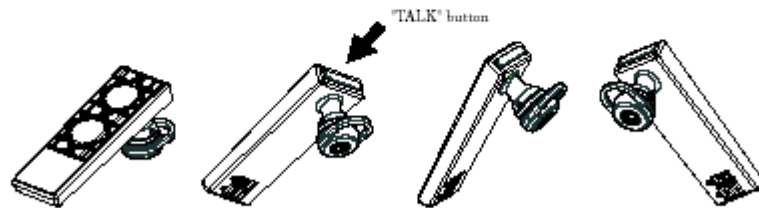

[www.tuv.com](http://www.tuv.com)

### Packaging content

1 Dior Bluetooth® headset, 1 international warranty card,  
1 user manual, 1 car charger, 1 USB extension cable,  
1 USB adapter, 4 ear buds, 2 hooks, 1 travel case.  
The packaging content may vary in accordance with regional regulations.

### Technical specifications

Weight: approximately 9.5 g, ear buds: 4 different sizes, talk time: 4 hours,  
standby time: 6 days, time of charge: 2 hours, distance: 10 meters,  
bluetooth: 2.0, acoustic characteristic: noise suppression, echo suppression.

### Customer care

For further information on the product or on customer care,  
please check on [www.diorphone.com](http://www.diorphone.com) for Dior hotline phone  
numbers and customer care centers.

### Before using the Dior Bluetooth® headset

1. Charge until the red indicator light turns off (about 2 hours).  
Please refer to the "Charging the headset" section of this manual.
2. Pairing it with your mobile phone.  
Please refer to the "Pairing the headset" section of this manual.

### Fitting the ear bud

4 different sizes of ear buds are included in the pack to suit your ear size.  
You can adjust the ear bud position that you feel the most comfortable.

### Placing the headset hook

- 2 different sizes of hooks are included in the pack to suit your ear size.  
Click the hook on the speaker and place it around your ear.

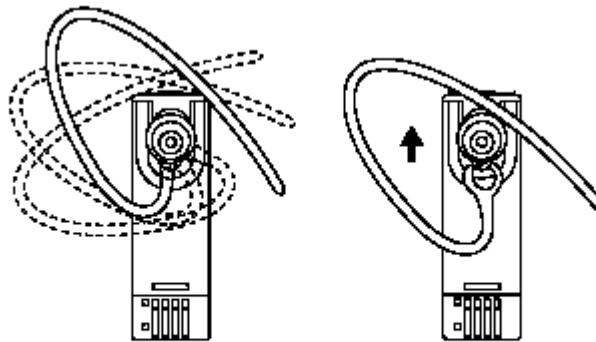

### Wearing the headset

To optimize the headset performance,  
wear your headset on the same side as your mobile.

You will get a better reception if there is no obstacle  
between the headset and your mobile phone.



## USING YOUR DIOR BLUETOOTH HEADSET

### Charging the headset

When the light flashes in red and you hear a small beep, the headset needs to be recharged.

To charge your Dior Bluetooth® headset, follow these steps:

Plug the Dior Bluetooth® USB extension on the headset if needed: diagram A

Plug the Dior Bluetooth® USB adaptor into the car charger if you want to charge the headset in your car: diagram B or to a powered USB slot of your computer: diagram C.

The light will turn red to indicate the headset battery is charging.

Once the light turns off, the headset is fully charged.

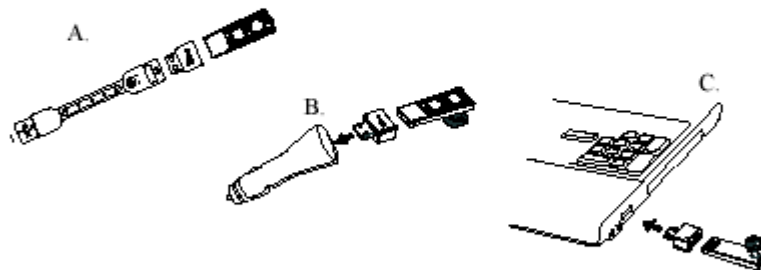

**Note:**

A normal charge takes approximately 2 hours.

When you haven't used your Dior Bluetooth® headset for a long time, it may take a few minutes before the charging battery indicator appears.

### Pairing the headset with a mobile phone

Before using the headset, you must pair it with your Bluetooth® mobile phone. Pairing is the process of linking two Bluetooth® devices, so that they can communicate. The process is only needed once for the same phone.

To initiate pairing, follow these steps:

1. Place the headset and your mobile phone close to each other (0.5 meter/1 foot)
2. Switch on your phone and select the Bluetooth® menu (refer to the Bluetooth® mobile phone user manual).
3. Select "Search for audio device".

If prompted to power on Bluetooth first, press the [YES] soft key.

4. To initiate pairing on the headset, make sure it is OFF, then press and hold the TALK button for approximately 5 seconds until the headset indicates the pairing mode: the indicator light flashes in red and blue alternately and a sound can be heard in the speaker.

5. Once the mobile phone detects the headset, the phone screen displays "Dior Bluetooth headset".

Follow the instructions on the screen phone to accept the pairing. The password is "0000". [Four times zero]



If you haven't started the Bluetooth® mode within 5 minutes, the headset will go to the standby mode. You must then switch off your headset and start the pairing again. When pairing is successful, the headset will connect automatically to the mobile phone. For some phones, you may need to select "Connect".

### Switching your headset On and Off

To switch ON your headset, press and hold the TALK button for approximately 2 seconds until the blue indicator light is on; you will hear a beep sound.  
To switch OFF your headset, press and hold the TALK button for approximately 5 seconds until the red indicator light is on; you will hear a beep sound.

### Making a call

Make sure both the headset and the mobile phone are ON and connected.  
Dial the number on the phone keypad,  
after approximately 2 seconds the audio connection will be established.

If your mobile phone has the function "voice recognition"<sup>4</sup>,  
activate it and make sure your voice tags have been recorded with this phone.  
To enter these, please refer to your phone's manual.

Press once the TALK button; you will hear a short tone.  
Then tell the name of person you wish to call, after approximately 2 seconds the audio connection will be established.

<sup>4</sup>This function may not be available depending on the phone.

### Ending a call

Press once on the TALK button to end a call.

### Accepting or rejecting a call

When receiving a call, press the TALK button once to take the call or  
for approximately 2 seconds to reject a call.



### Redialing the last number

Press the TALK button for approximately 2 seconds:  
you will hear a beep sound. Then the phone will automatically dial the last number.  
This function is only available in hands-free profile.

### Adjusting the speaker volume

Adjust the volume directly from your mobile phone.

### Muting the microphone

You can directly manage this function with your mobile phone.  
Please refer to your phone's manual.

### Double call\*

While you have a phone call, you will hear a call waiting alert:

1. Press the talk button for approximately 2 seconds  
to accept the second call and place the current call on hold.
2. To end the active call and take the hold call,  
press the TALK button once.

\*This function may not be available, depending on the phone.  
However, you can always answer the second call from your phone keypad.

## WARRANTY & REGULATION

Your Dior Bluetooth® headset is covered by an international warranty against any manufacturing defects for a period of 12 months from the date of purchase shown on the warranty card. If, during this period, such a defect becomes apparent, the defective parts will be replaced free of charge. Any defect in your Dior Bluetooth® headset must be duly identified by our technical department.

The warranty excludes, in particular, defects resulting from:

- Improper treatment (shocks, crushing, etc.), accidents, alterations modifications;
- Improper handling when charging (only Dior certified charger should be used);
- Any operation not carried out by qualified personnel in our network could seriously damage your Dior Bluetooth® headset for which we cannot be held responsible.

The fully completed warranty card (showing references, name of the Dior dealer, date of purchase and signature) must be shown in order to benefit from free repairs under the terms of the warranty. A defective Dior Bluetooth® headset and the warranty card may either be taken to an official Dior phone dealer or sent to one of the Dior repair centers.

### For your safety

For your safety, please refer to the guidelines prior to using your Dior Bluetooth® headset. Failure to comply with the guidelines may cause malfunctions or be hazardous to the user.

### Road safety comes first

Please, check the regulation in your area if you plan to use your headset while driving.

### Switch off in aircraft

All Bluetooth headsets may be subject to radio interference with the aircrafts navigation system. Please make sure the Dior Bluetooth® headset is in switched off mode while in airplanes.

### Qualified service

It is highly recommended to have repairs done by qualified service personnel.  
Use only approved accessories.

### Hearing safety

The volume level of the Dior Bluetooth® headset may vary,  
depending on your mobile phone.  
Before using your headset for the first time, adjust the volume to the lowest,  
then increase the volume gradually until you reach to an acceptable level.  
This product respects the current regulations for limiting the output volume of  
consumer audio devices to a safe level.  
By listening at high volumes, you run the risk of permanent damage to your ears.  
Even if you get used to listening at high volumes and it seems normal to you,  
you still risk the possibility of damaging your hearing.  
Reduce the volume of your device to a reasonable level to avoid permanent  
hearing damage. If you hear ringing in your ears, reduce the volume.  
If you experience ringing in your ears or muffled speech,  
consult your doctor immediately and stop using the headset.

### Precautions when using batteries

Never use any charger or battery that is damaged in any way.  
If your headset is fully charged, the red indicator light will  
not turn on when plugged into the charger.  
If you leave your headset battery empty for an extended  
period of time, it could discharge the battery.  
In this case, charge your headset for 2 hours or more until  
the battery recharges completely.  
When you first charge the headset after a long inactivity,  
it may take few minutes for the red indicator light to turn on.

Battery life depends on signal strength, usage, and many other factors.  
Battery life and charge cycles vary by use and settings.  
To use of any other charger will automatically suspend the warranty.  
It is strictly forbidden and can be very dangerous.  
Extreme temperatures will affect the charging capacity of your battery:  
it may require cooling or warming first.

#### Care and maintenance

Your Dior Bluetooth® headset is a product of superior design and craftsmanship and should be treated with care.  
The suggestions below will help you fulfill the warranty obligations and enjoy this product for many years.  
Keep the Dior Bluetooth® headset and all its parts and accessories out of the reach of small children.  
Do not attempt to open the Dior Bluetooth® headset's casing.  
Non expert handling may cause damages to your Dior Bluetooth® headset.  
Do not drop or knock the Dior Bluetooth® headset.  
Rough handling may damage the internal circuits.  
Avoid exposure to excessive heat, cold, moisture, dust or caustic environments as it may damage some electronic components. Temperature range: 0 - 40C°  
Do not use harsh chemicals, cleaning solvents or strong detergents to clean the Dior Bluetooth® headset. Wipe out with a dry cloth.

Please check on [www.diorphone.com](http://www.diorphone.com) for Dior hotline phone numbers and customer care centers.

### Environmental protection

Discarded electric appliances are recyclable !  
Please actively support us in conserving  
resources and protecting the environment by  
returning this appliance to the collection centres.  
Dispose of batteries according to local regulations.  
Do not dispose as household waste.



## Certification and safety approvals

We, ModeLabs Manufacture, located 11bis rue Roquépine, 75 008 Paris, France declare under our sole responsibility that our product Dior Bluetooth® headset to which this declaration refers is in conformity with the appropriate standards EN300 328-02, EN301 489-17, EN301 489-01, EN5057, EN60950 following the provisions of Radio and Telecommunication Terminal Equipment directive 1999/5/EC.

Serge Simon, General Manager

The technical documentation will be kept at ModeLabs Manufacture 11 bis, rue Roquépine, 75008 Paris / France and will be available upon request.

This product is CE marked according to the provisions of the R&TTE Directive (99/5/EC).

We declare that this product is in compliance with the essential requirements and other relevant provisions of Directive 1999/5/EC. For further information, please refer to the website : [www.diorphone.com](http://www.diorphone.com)

## FCC declaration

This device complies with Part 15 of the FCC Rules.  
Operation is subject to the following two conditions:  
(1) this device may not cause harmful interference,  
and (2) this device must accept any interference received,  
including interference that may cause undesired operation.

In compliance with Industry Canada regulations, technical specifications have been provided in a declaration of conformity.  
This does not imply that industry Canada approved the equipment.  
Changes or modifications not expressly approved by the party responsible for compliance could void the user's authority to operate the equipment.