

Figure 9.1.1 30 kW S-BAND/U Antenna Group - Overall View

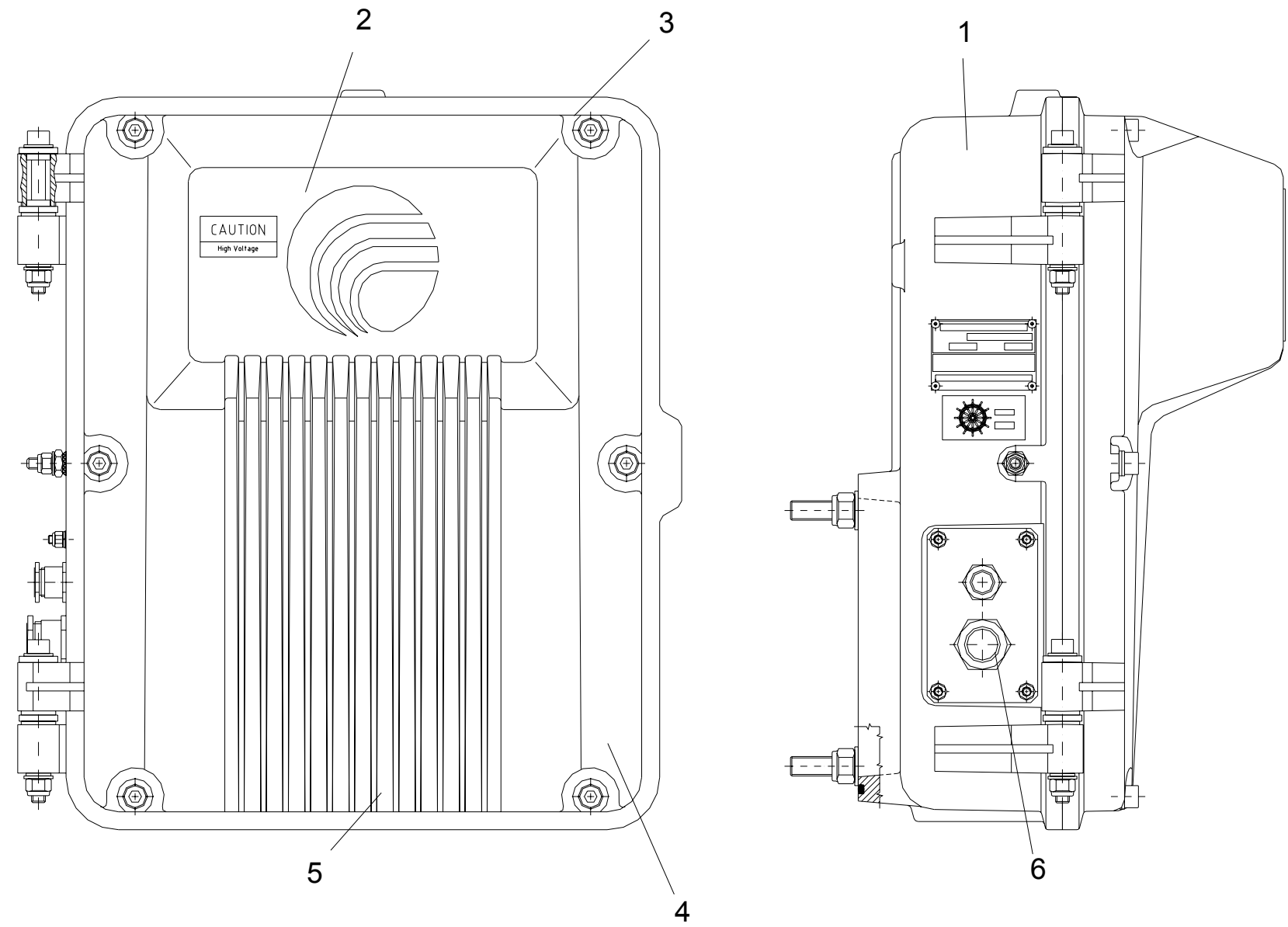

Figure 9.1.2 RTM 30S/U/D - External View

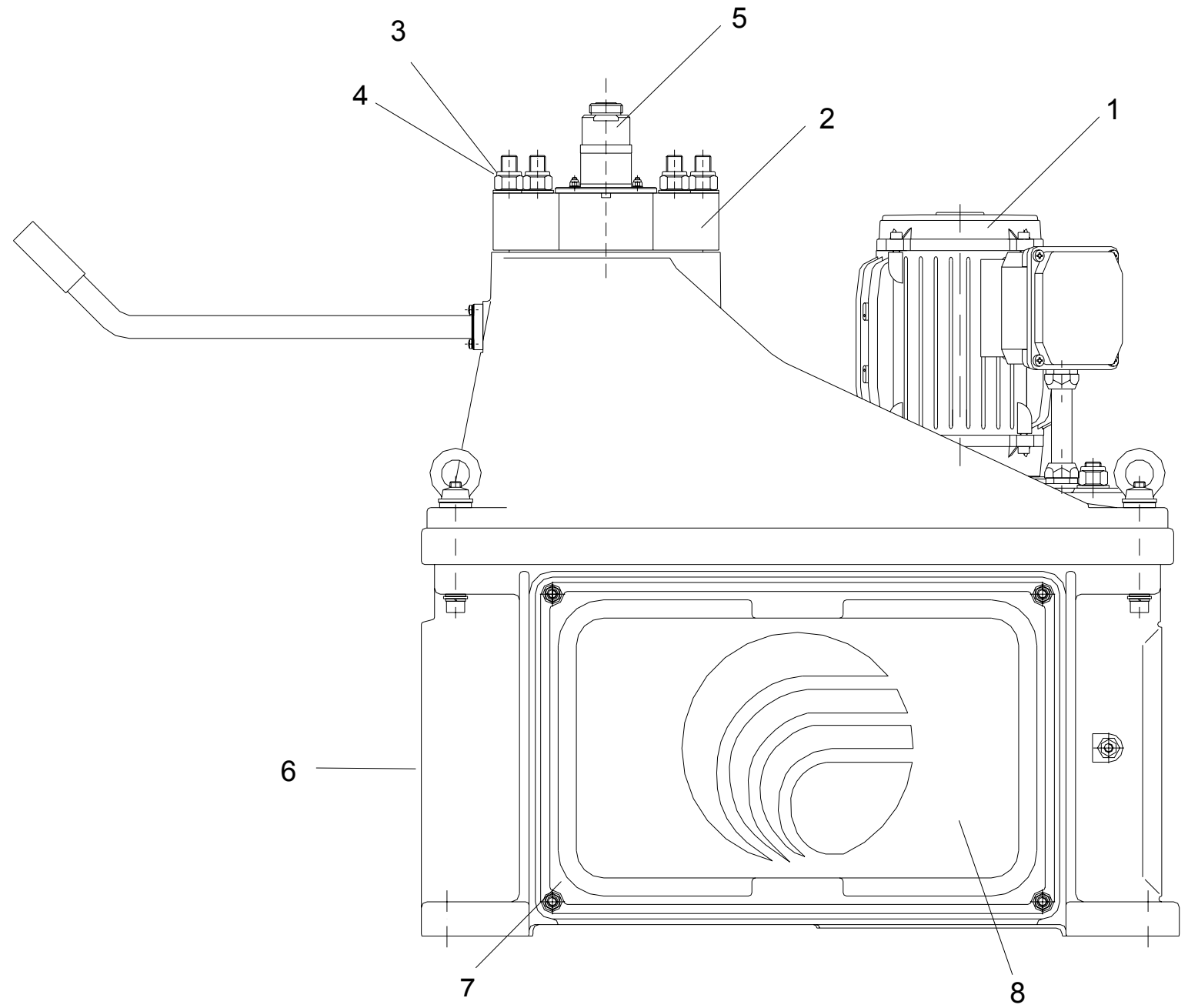

Figure 9.1.4 03R-039 Antenna Pedestal External View

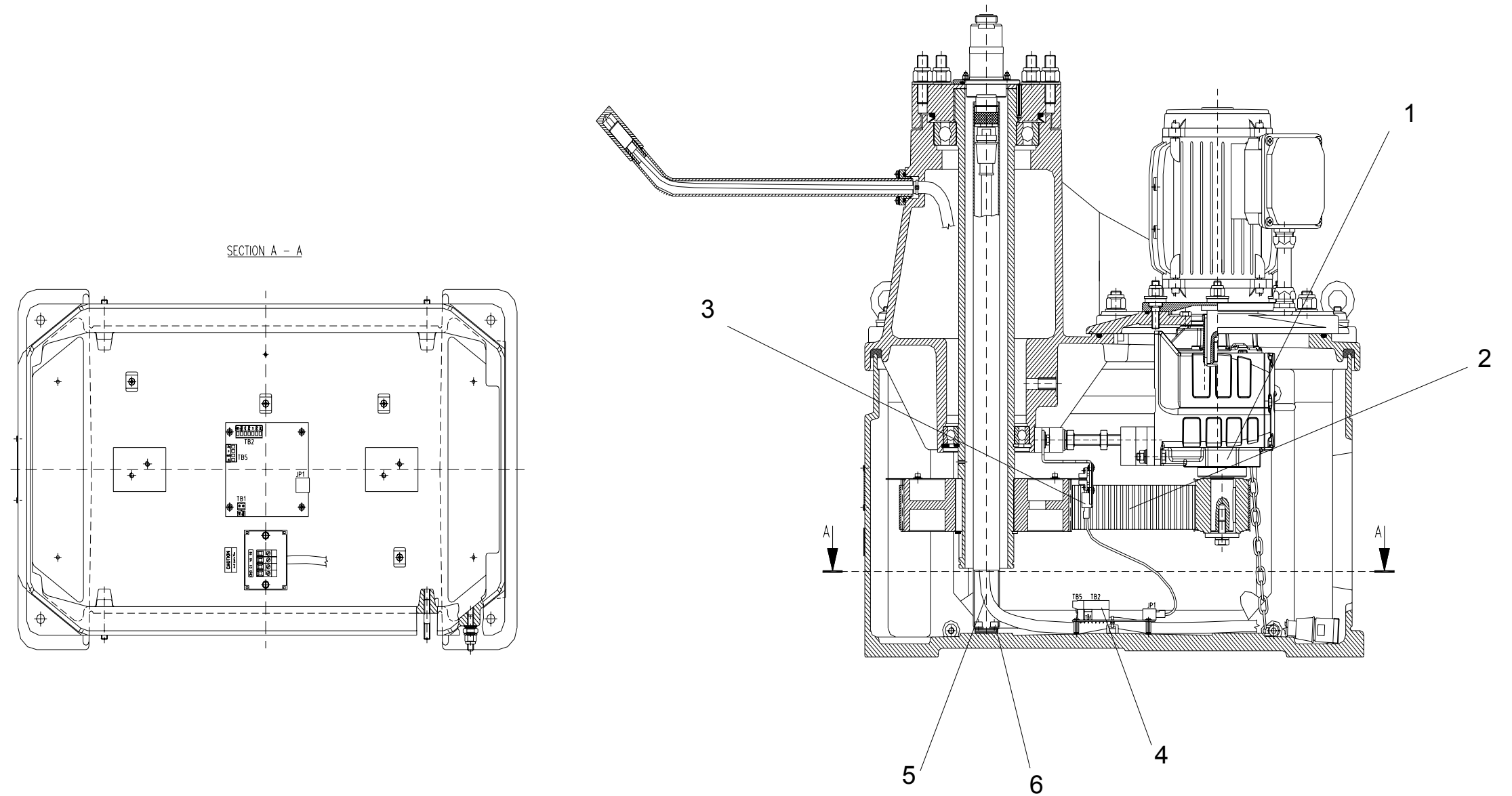

Figure 9.1.5 03R-039 Antenna Pedestal Internal View

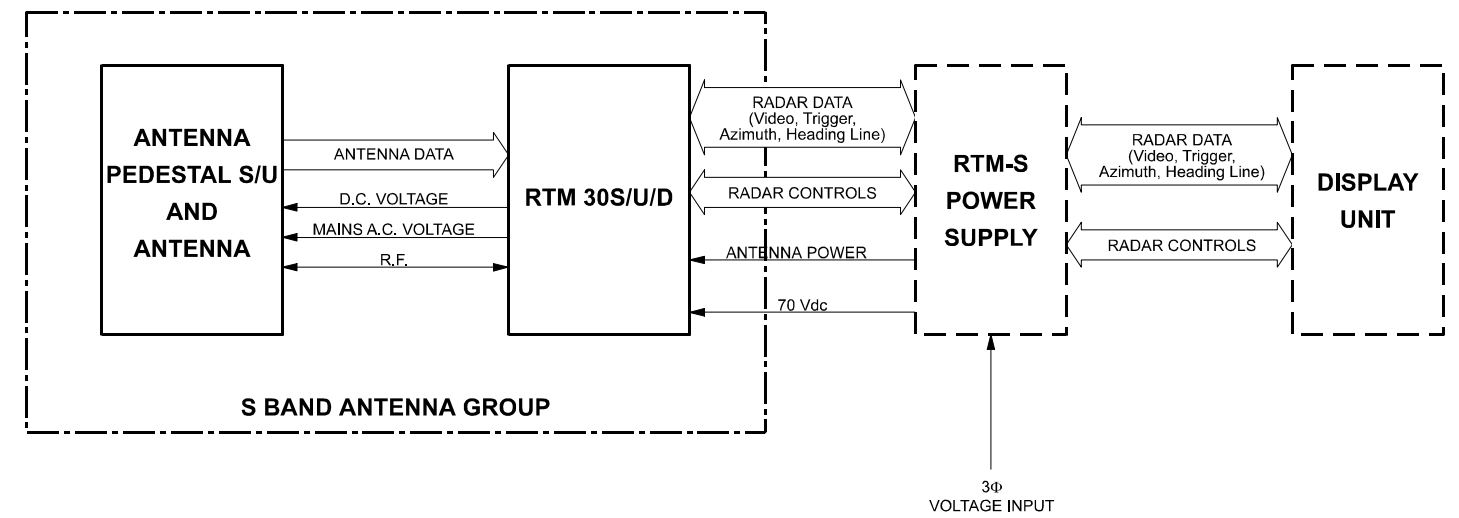

Figure 9.1.6 30 kW S-BAND/U Antenna Group Block Diagram

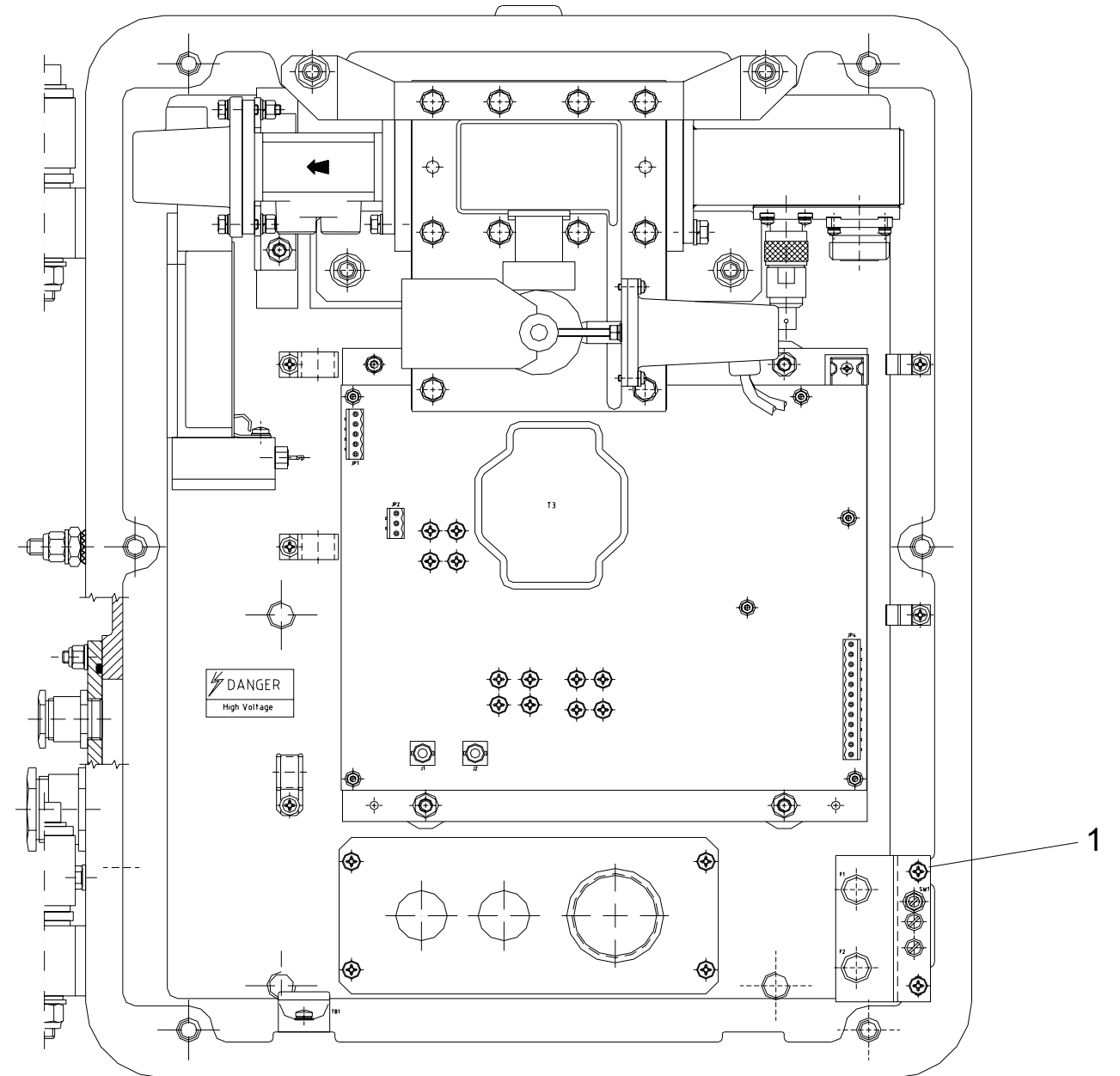

Figure 9.1.7 RTM 30S/U/D Unit - Internal View

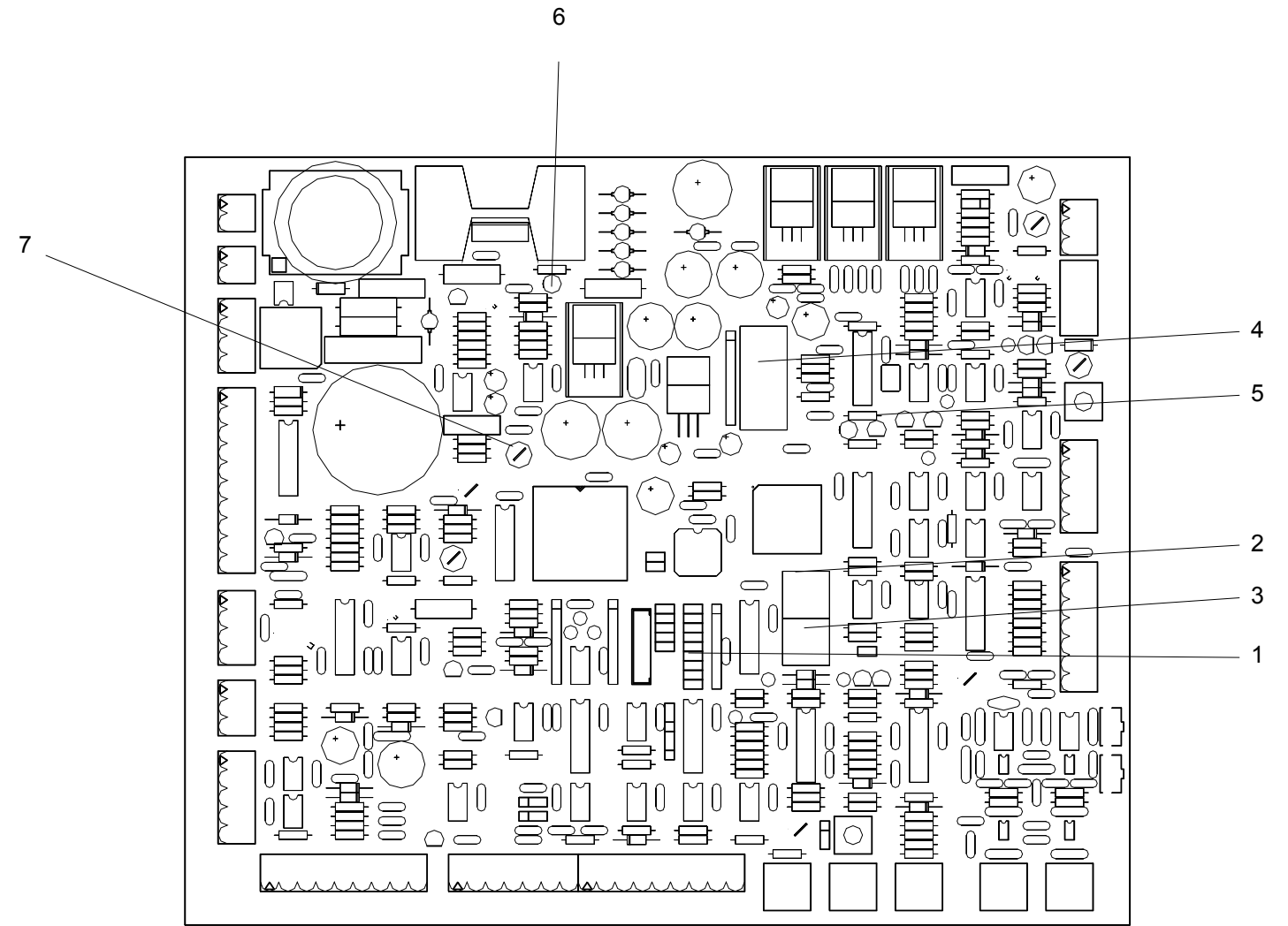

Figure 9.1.8 RTM 30S/U/D Unit - RTM CONT B Board

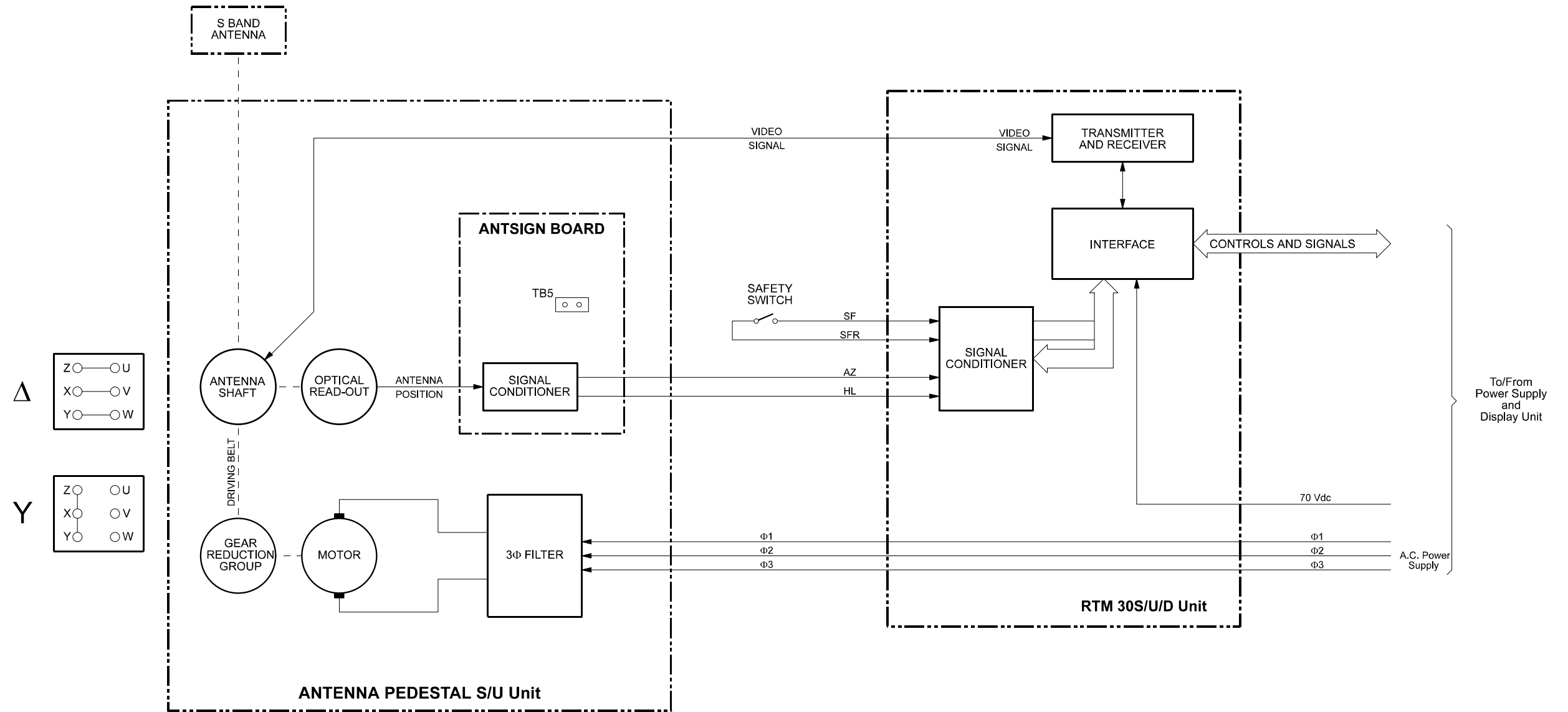

Figure 9.1.9 30 kW S-BAND/U Antenna Group Functional Block Diagram

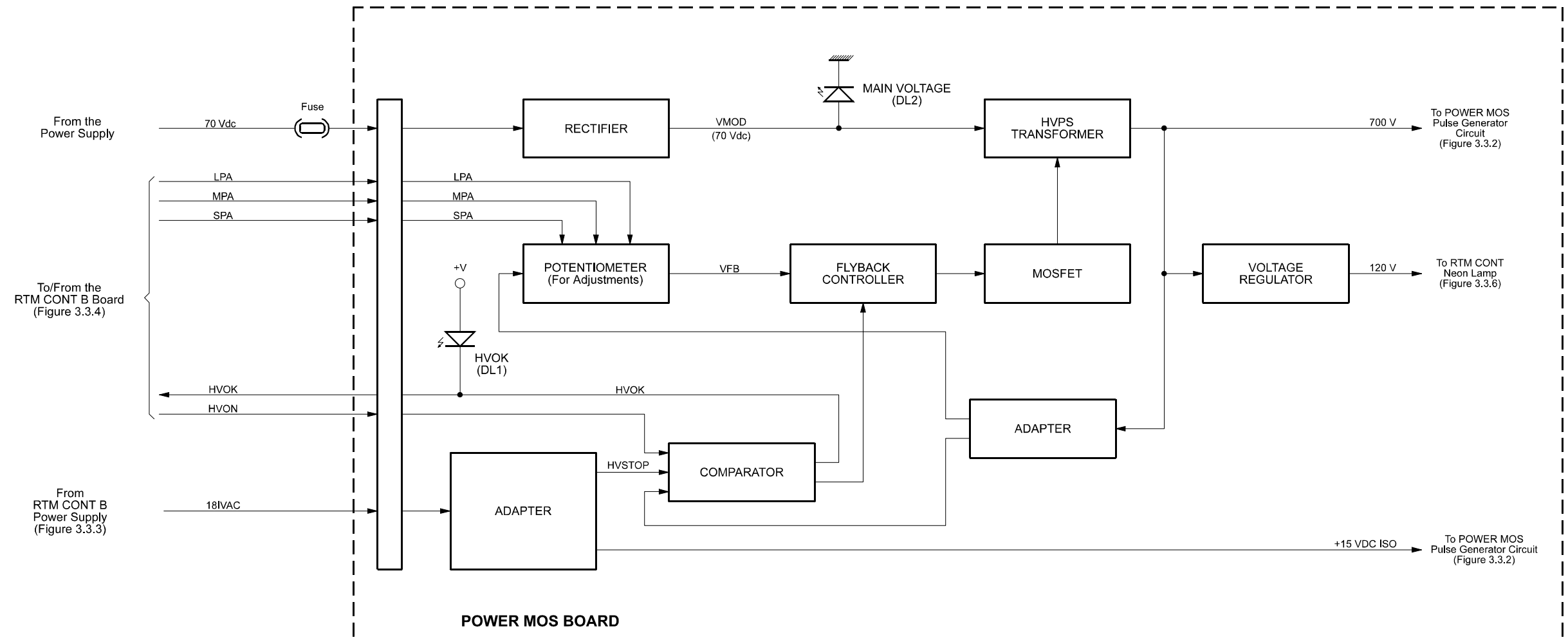

Figure 9.1.10 POWER MOS Board - HVPS Generator Circuit

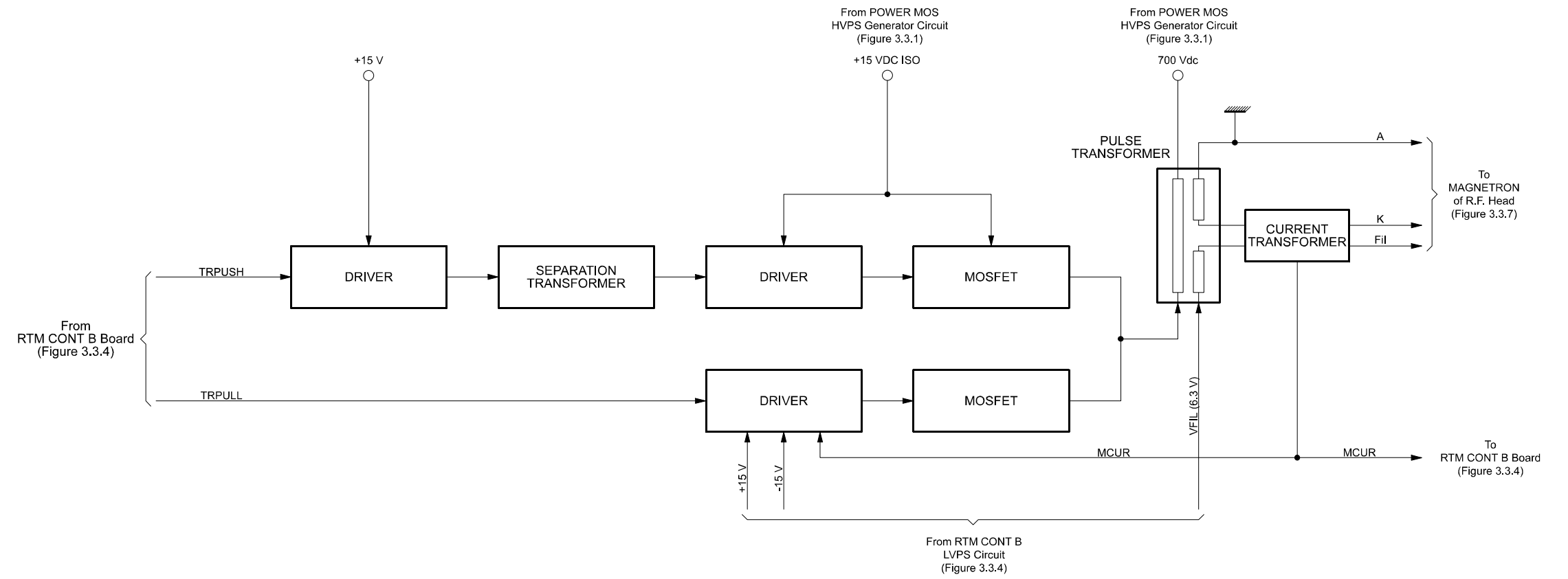

Figure 9.1.11 POWER MOS Board - Pulse Generator Circuit

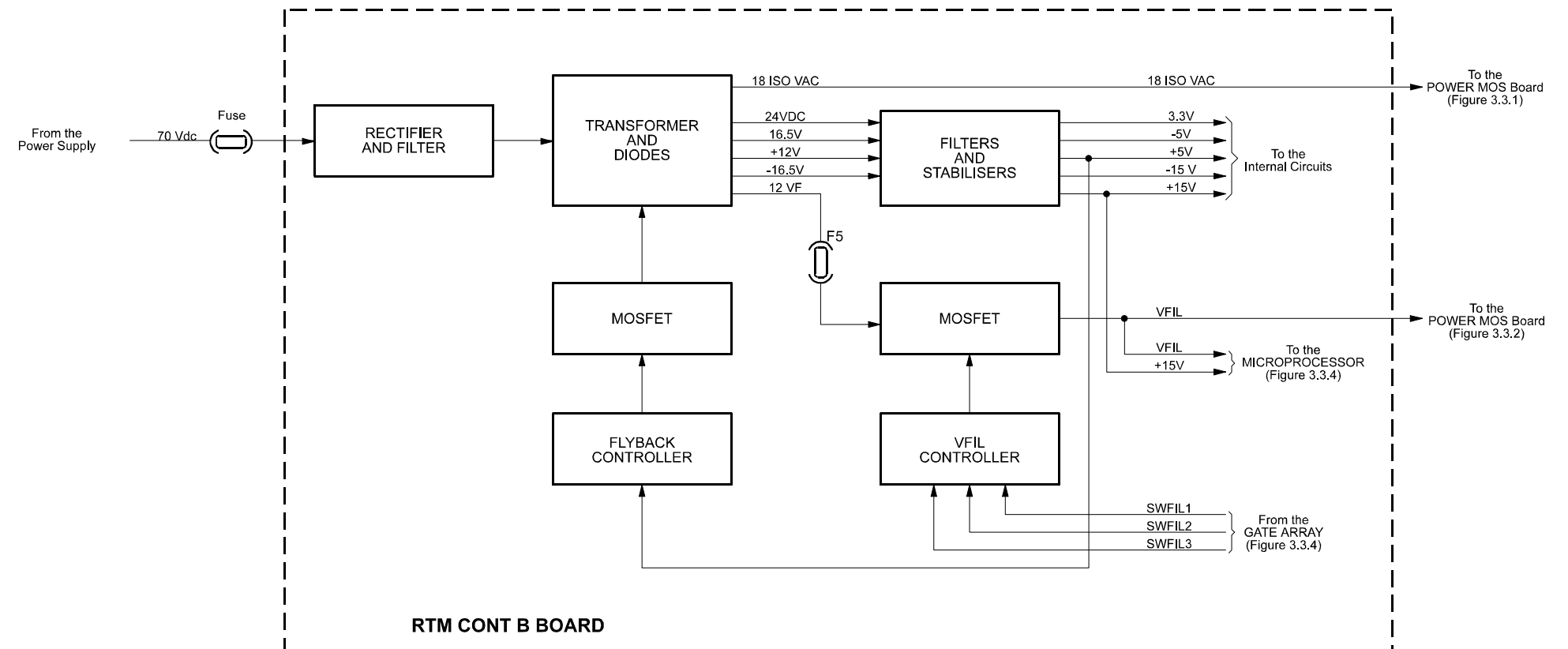

Figure 9.1.12 RTM CONT B board - LVPS Circuit

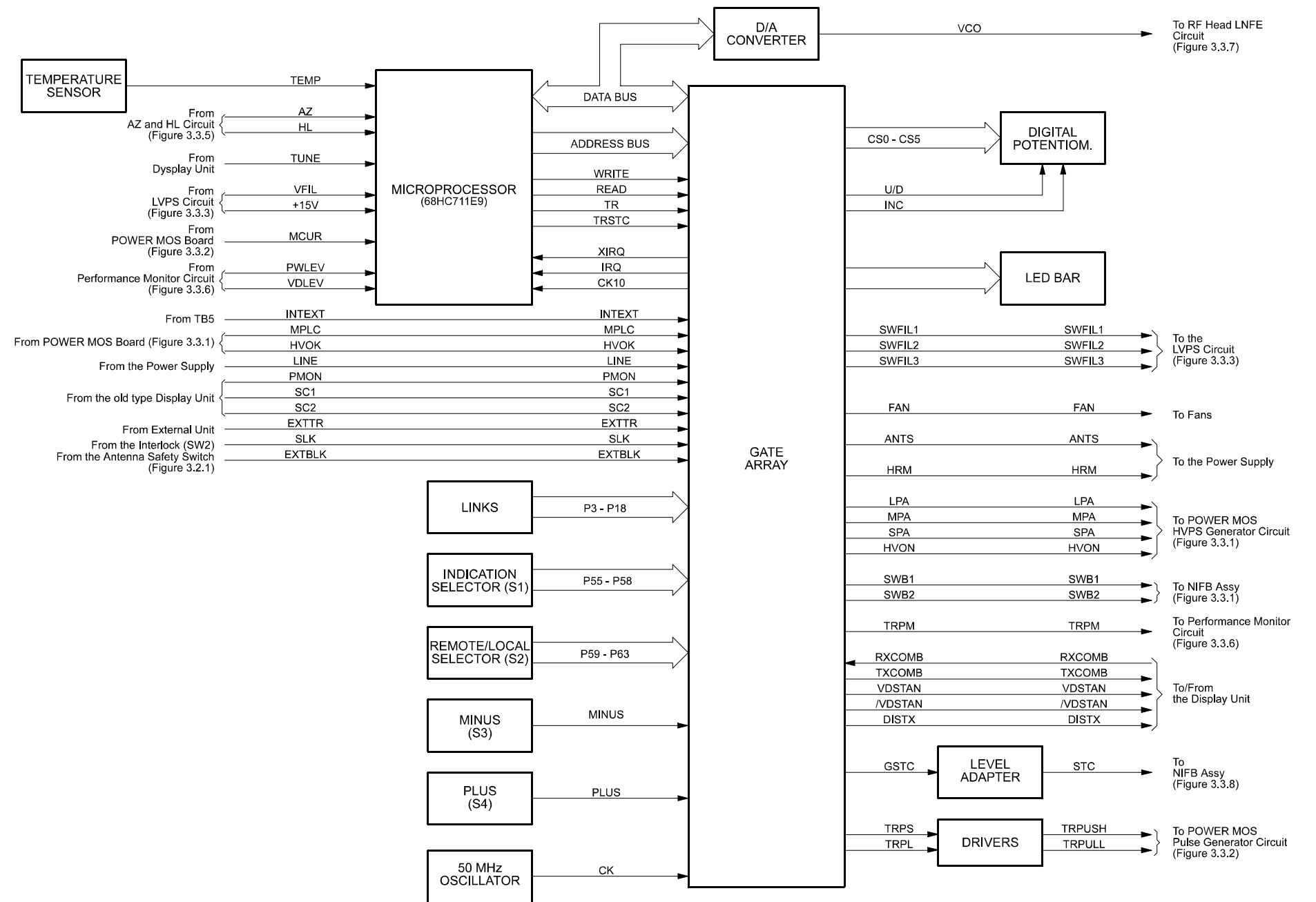

Figure 9.1.13 RTM CONT B board – Microprocessor

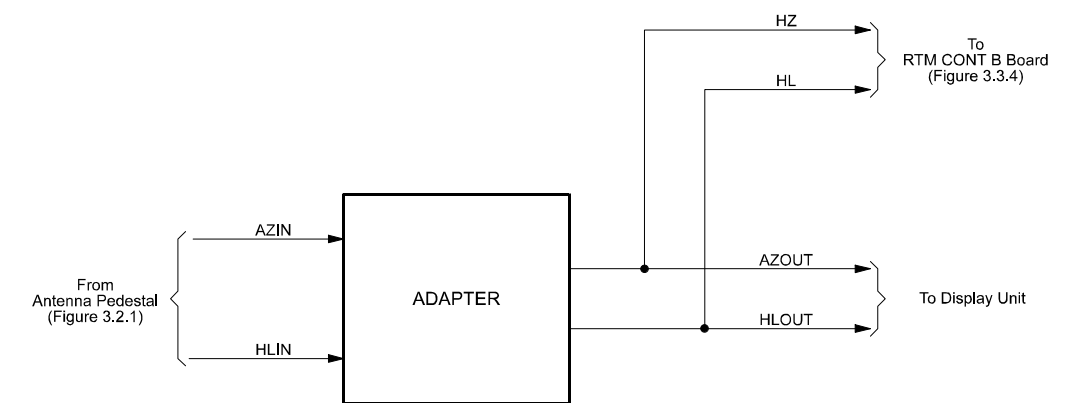

Figure 9.1.14 RTM CONT B board - AZ and HL Signals Generator Circuit

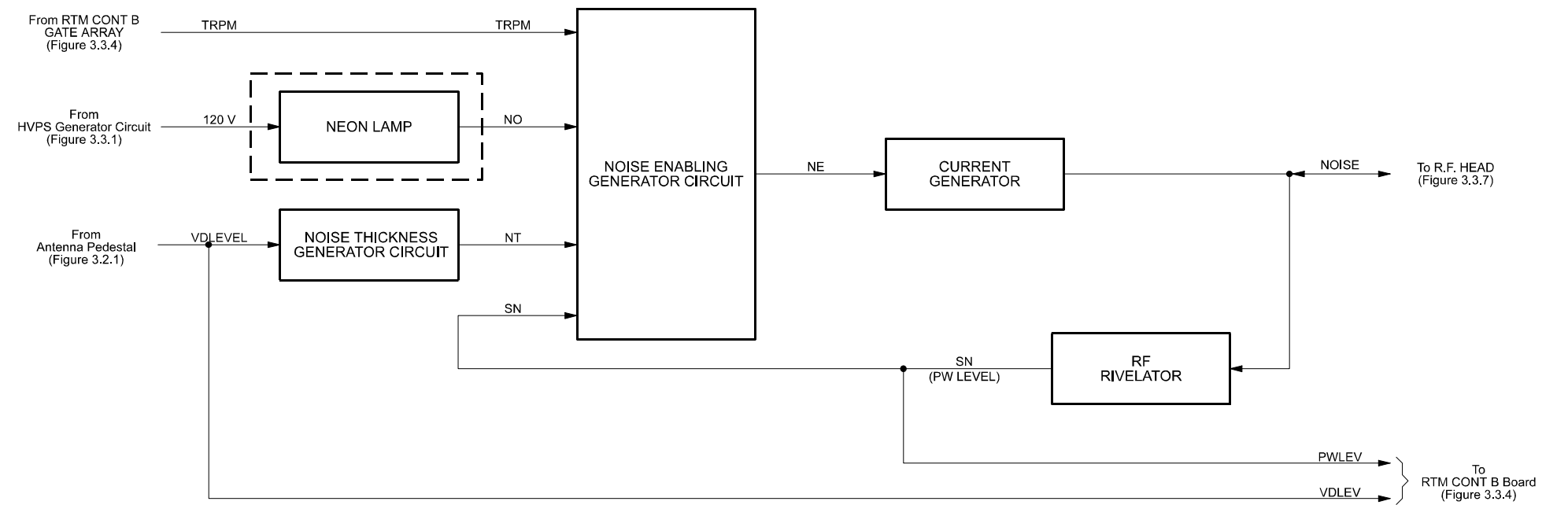

Figure 9.1.15 Performance Monitor Circuit

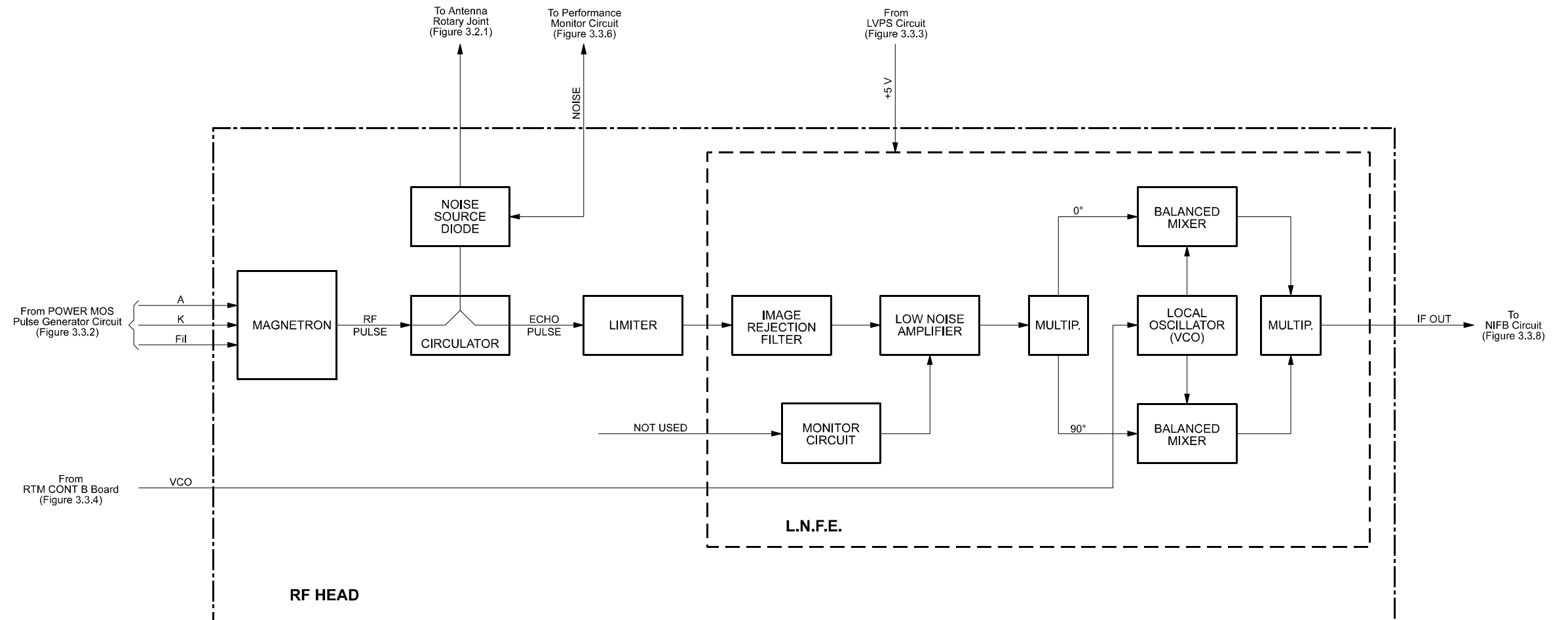

Figure 9.1.16 RF Head - Functional Block Diagram

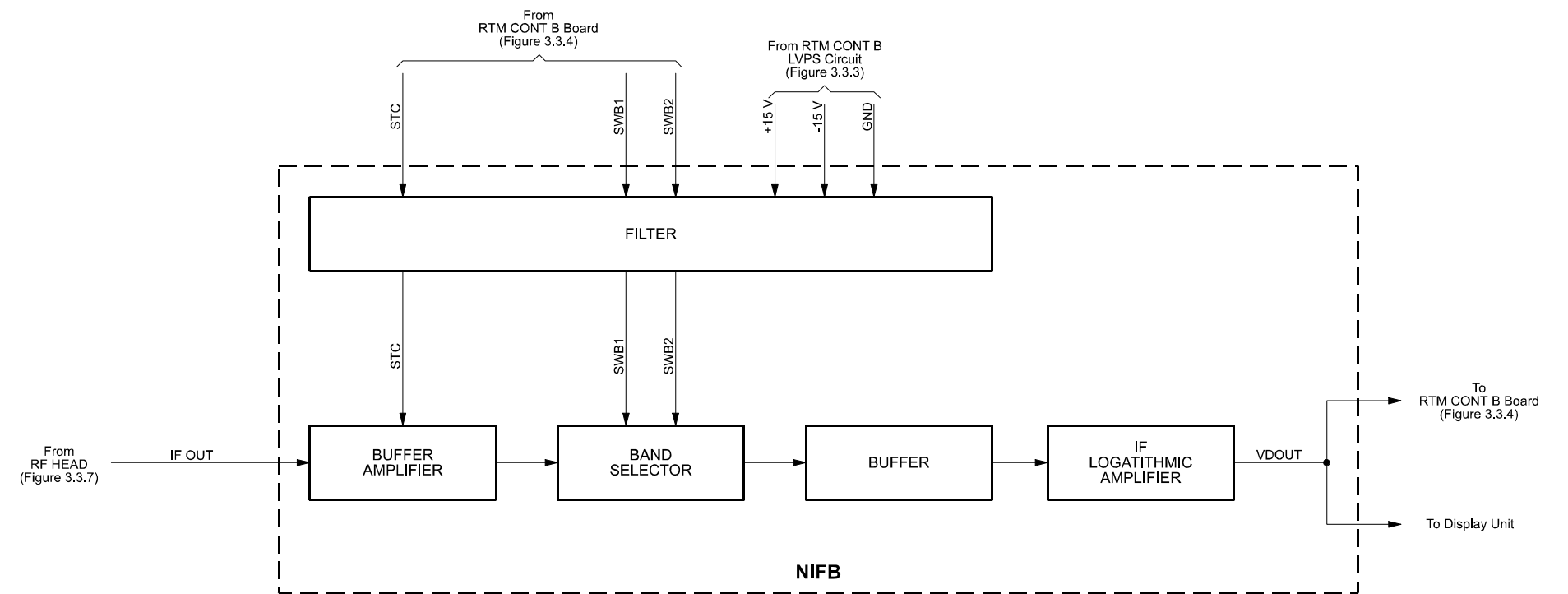

Figure 9.1.17 NIFB Assy

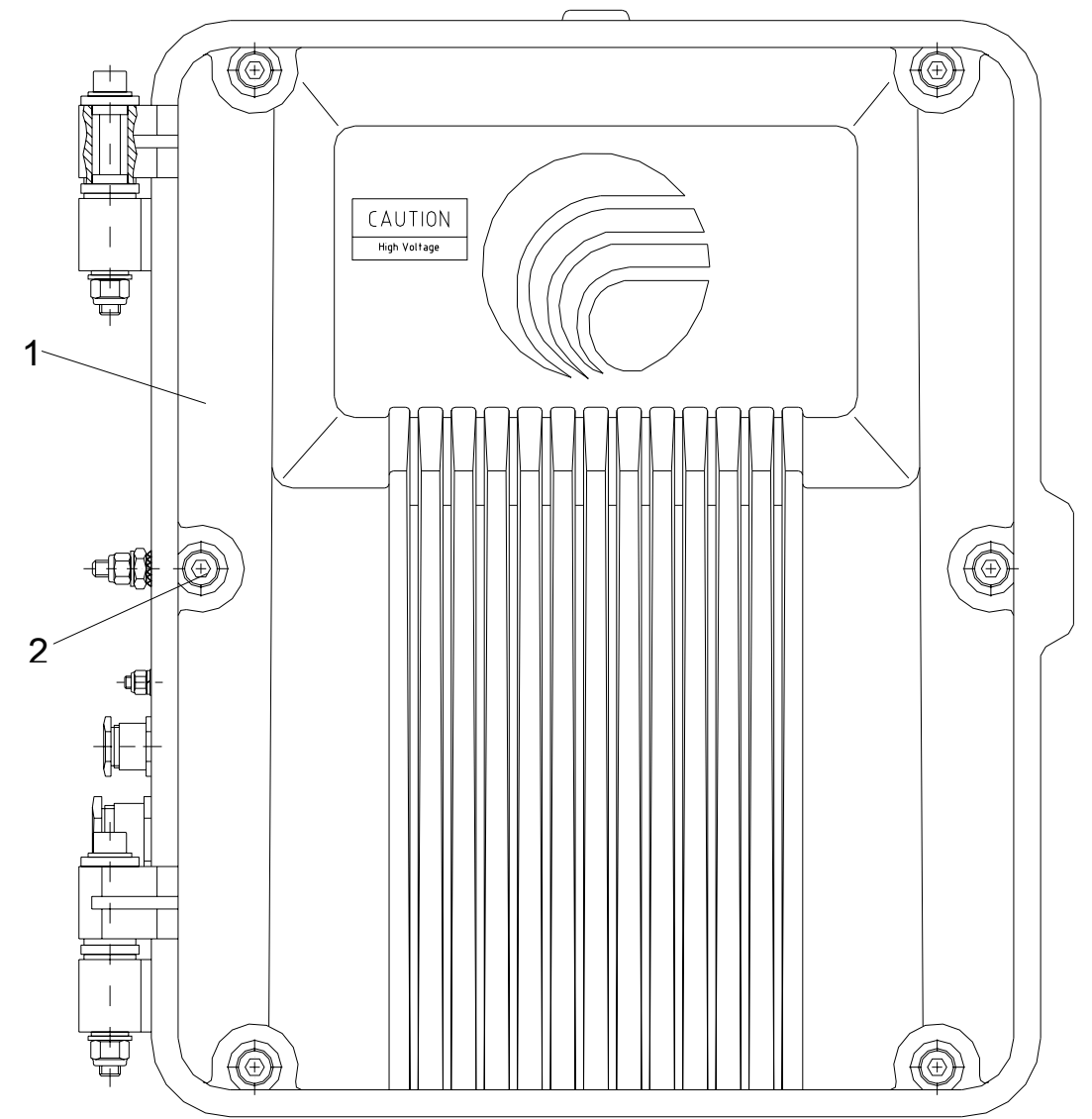

Figure 9.1.19 30 kW S-BAND/U Antenna Group - RTM 30S/U/D Unit Front View

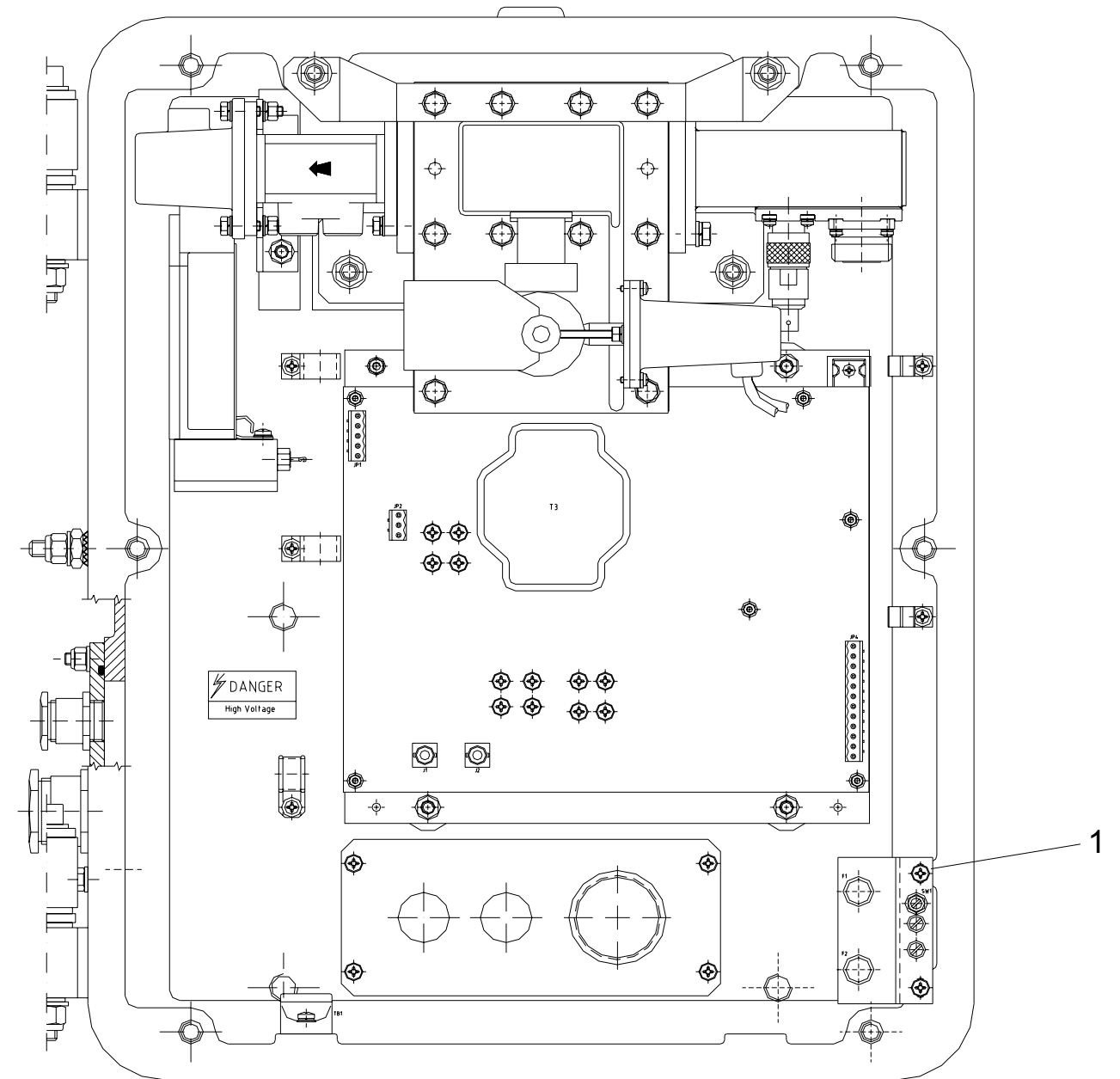

Figure 9.1.20 30 kW S-BAND/U Antenna Group - RTM 30S/U/D Unit Internal View

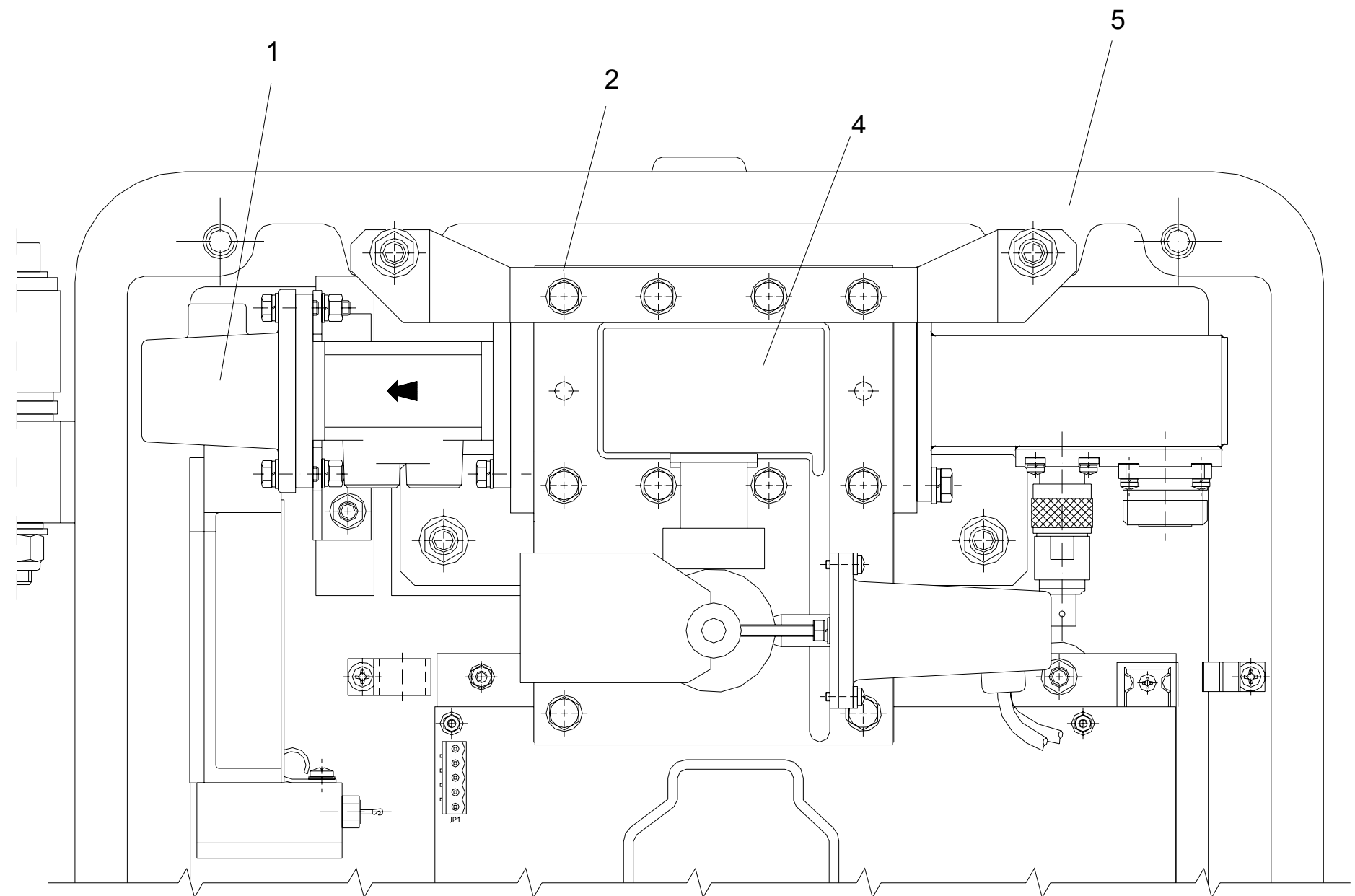

Figure 9.1.21 RTM 30S/U/D Unit - Particular of the Magnetron

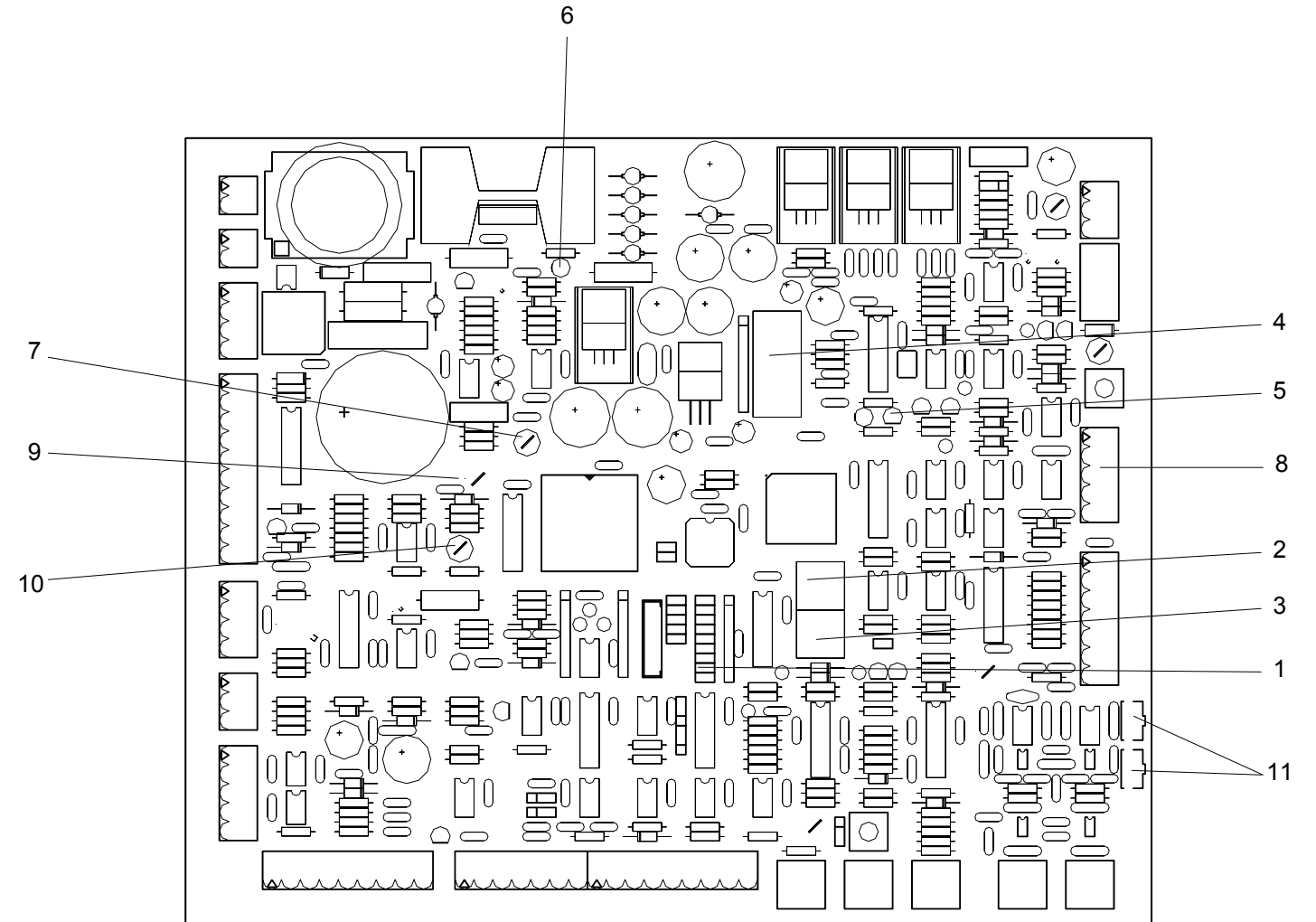

Figure 9.1.22 RTM 30S/U/D Unit - RTM CONT B board

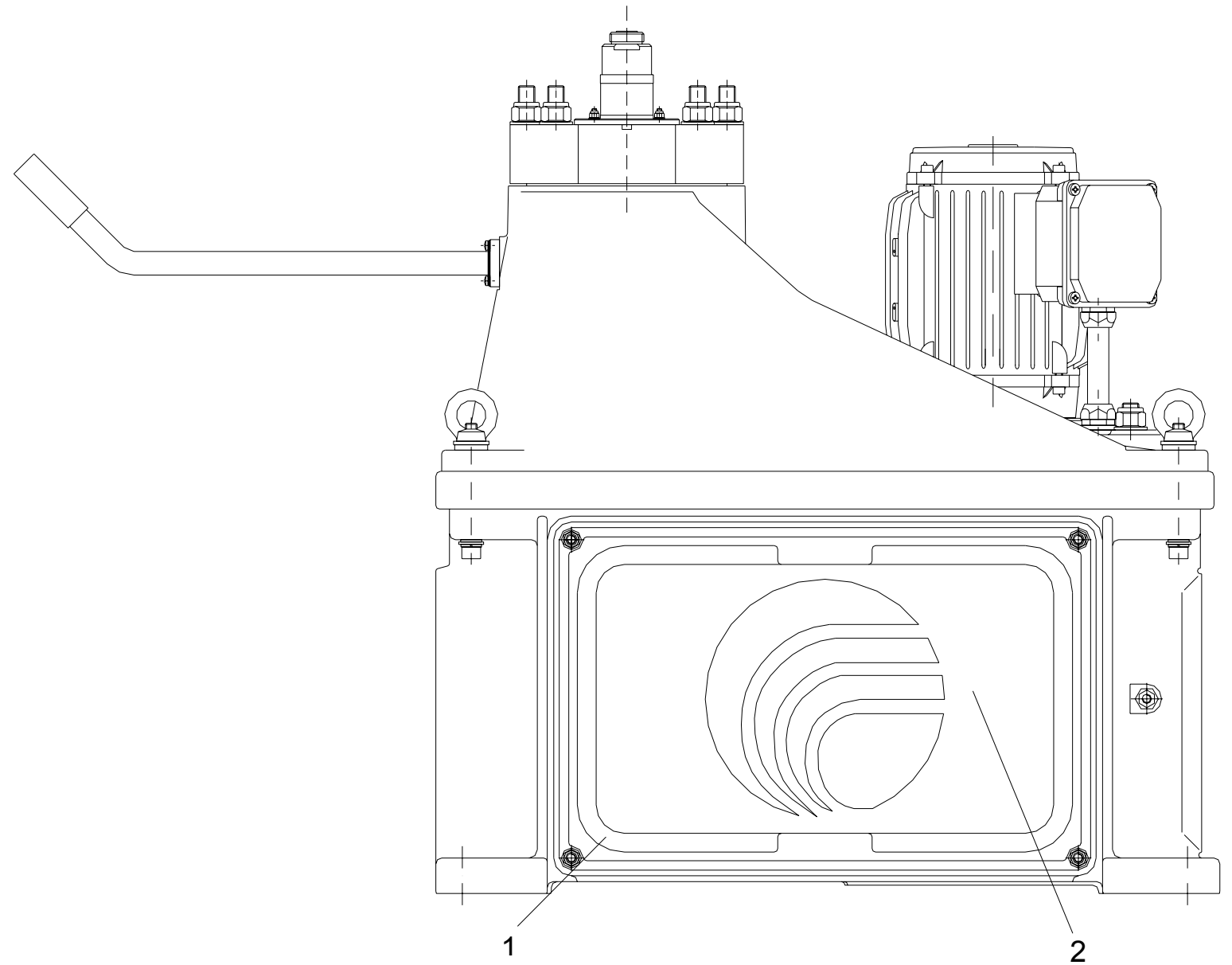

Figure 9.1.23 Antenna Pedestal S/U Unit - External View

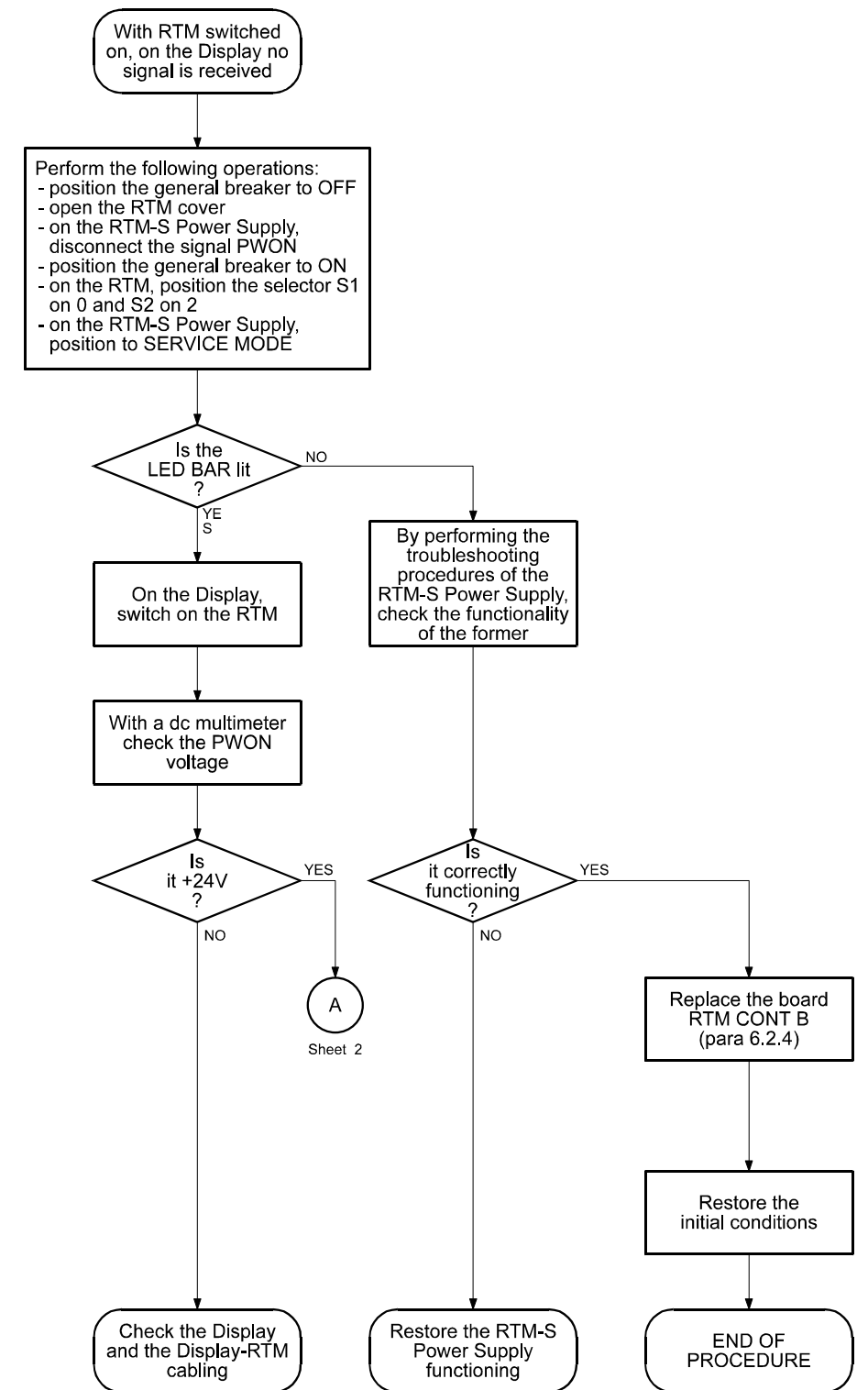

Figure 9.1.24 Chart 1
(Sheet 1 of 3)

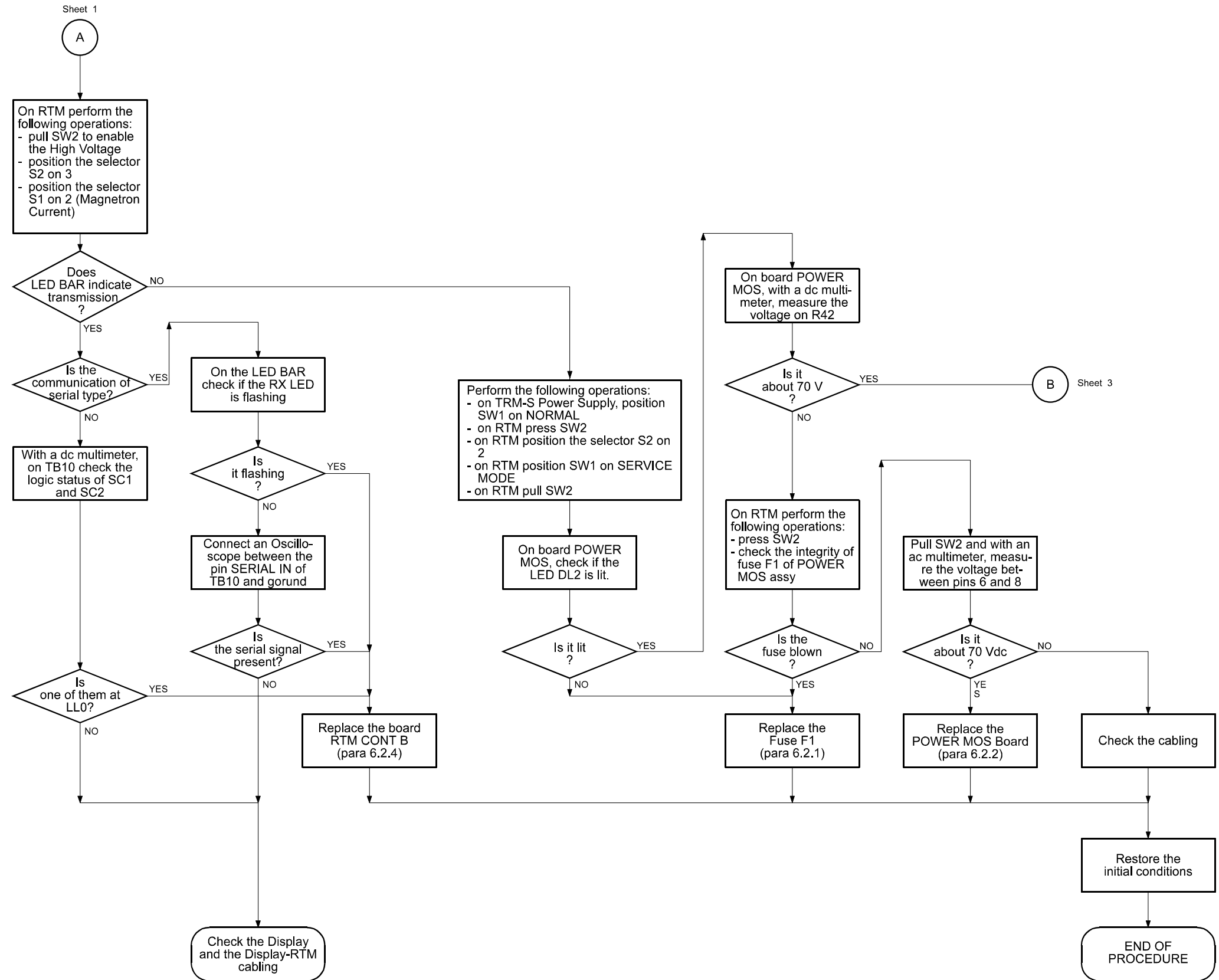

Figure 9.1.24 Chart 1
(Sheet 2 of 3)

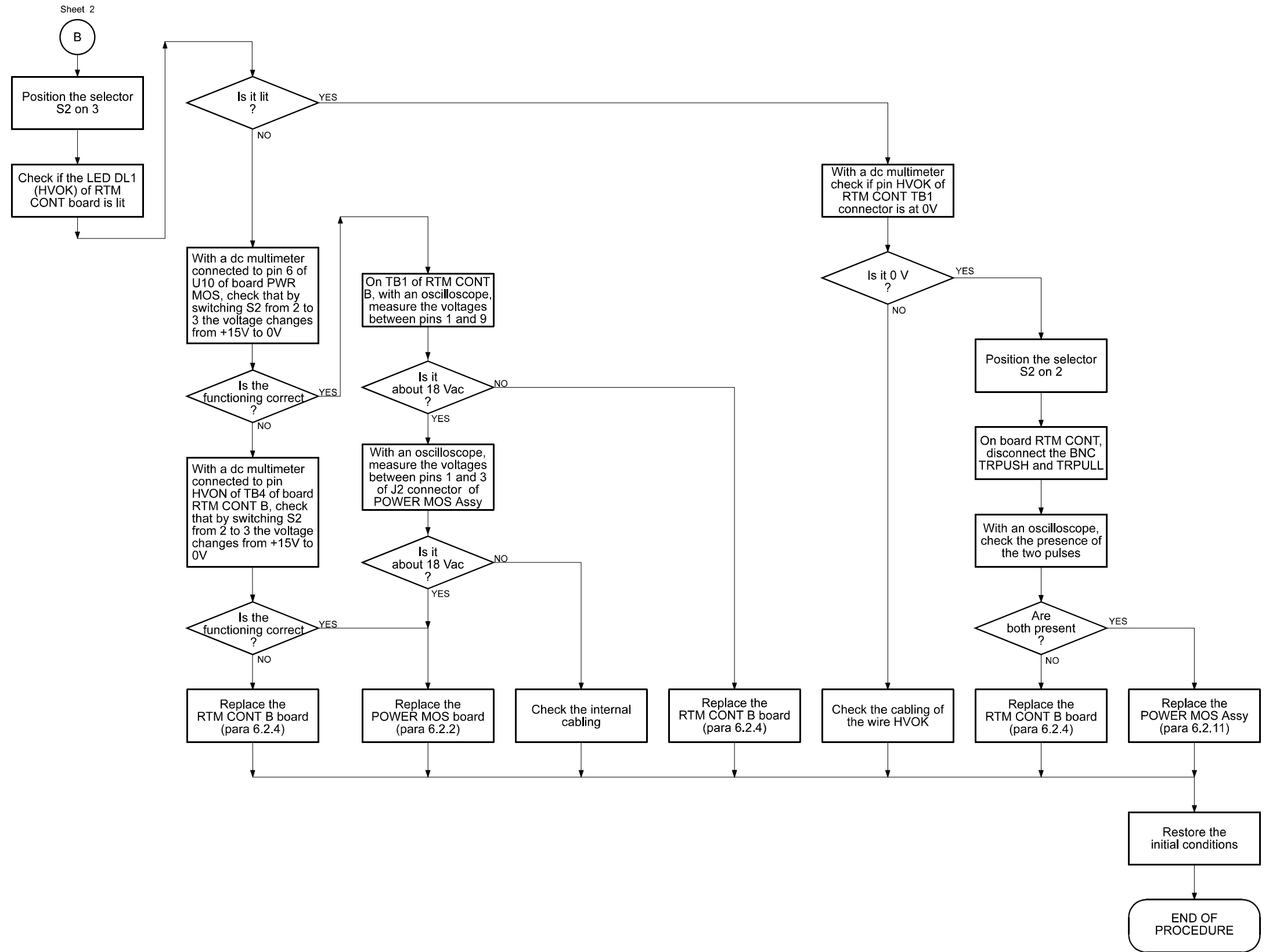

Figure 9.1.24 Chart 1
(Sheet 3 of 3)

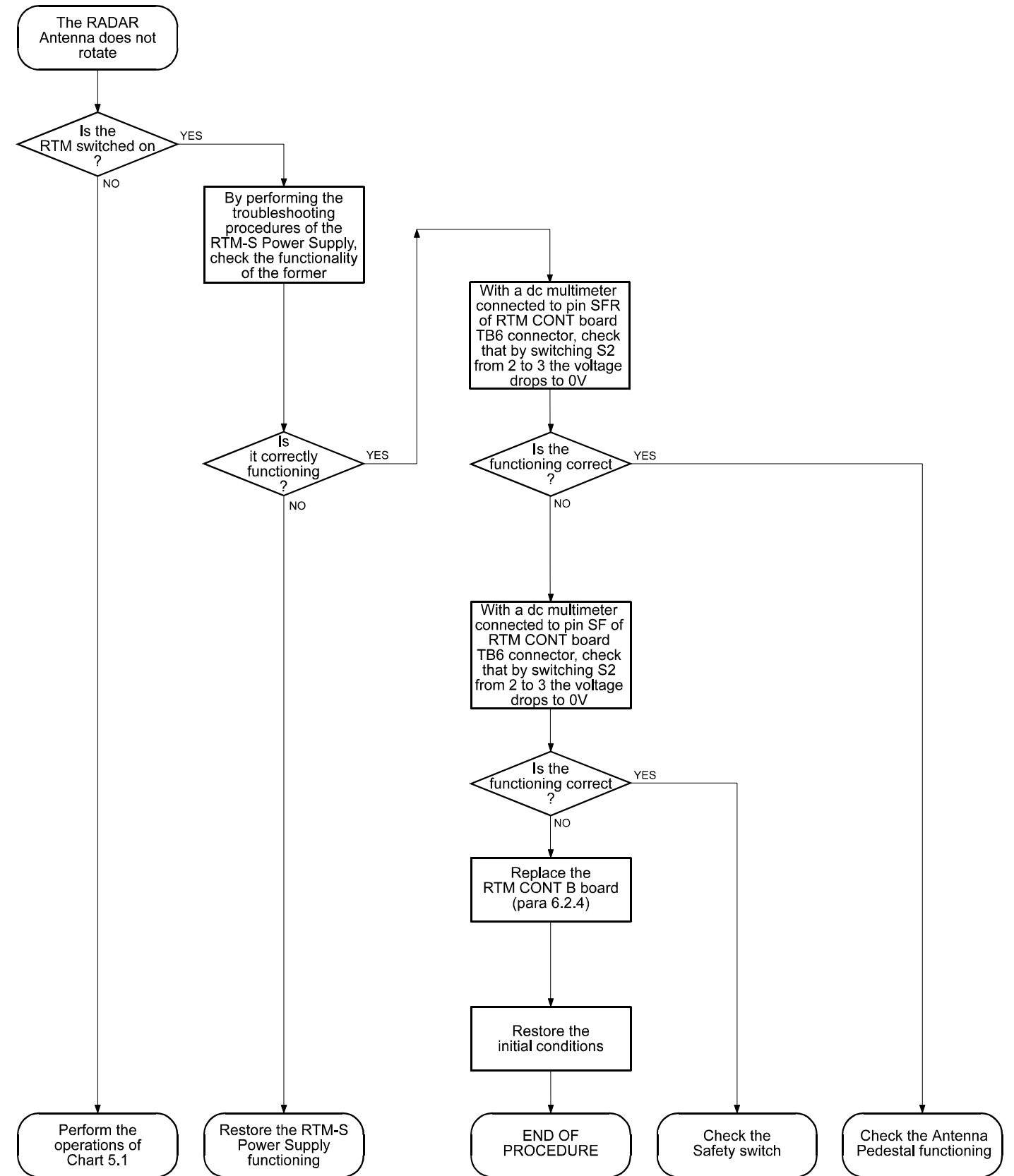

Figure 9.1.25 Chart 2

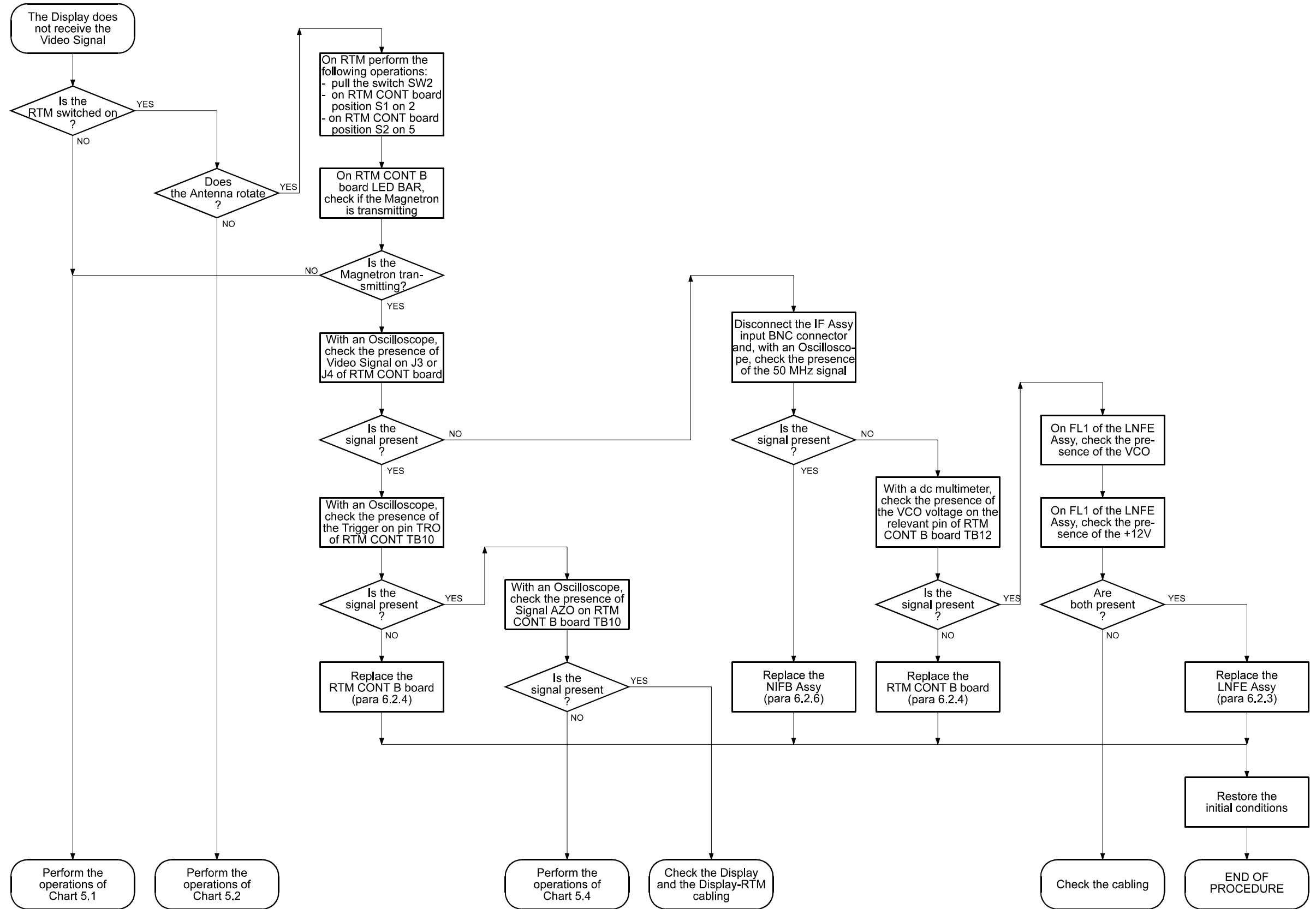

Figure 9.1.26 Chart 3

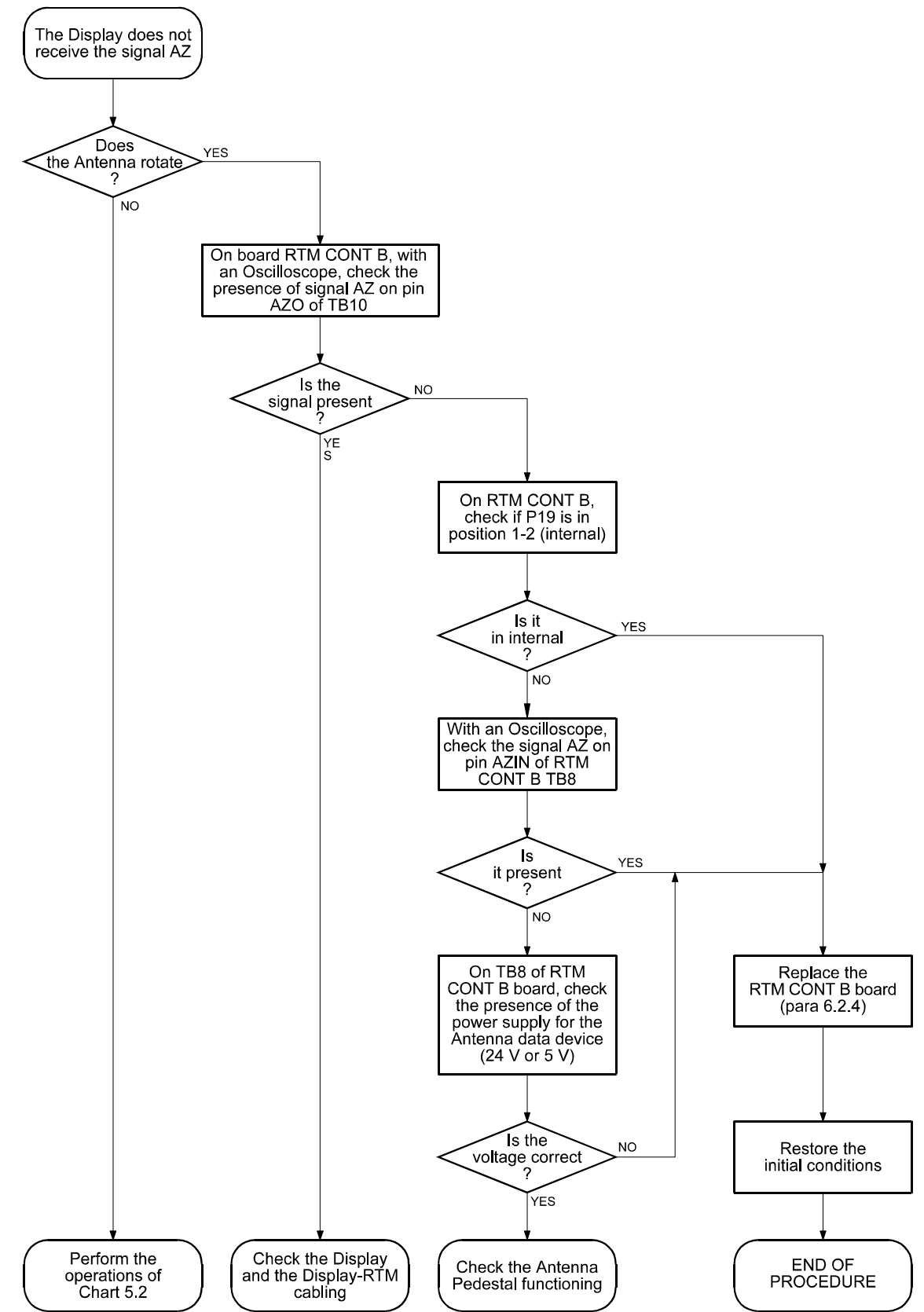

Figure 9.1.27 Chart 4

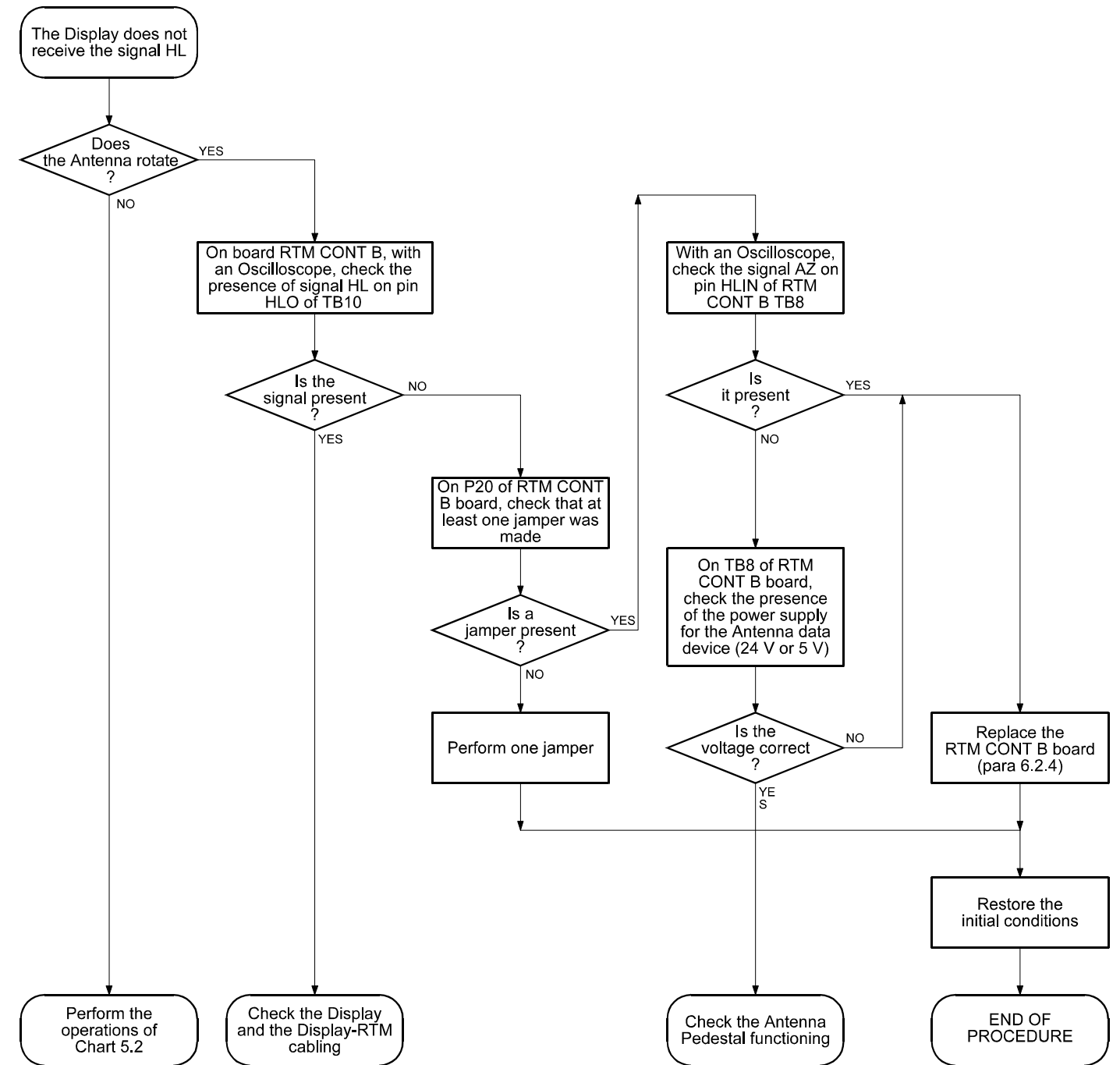

Figure 9.1.28 Chart 5

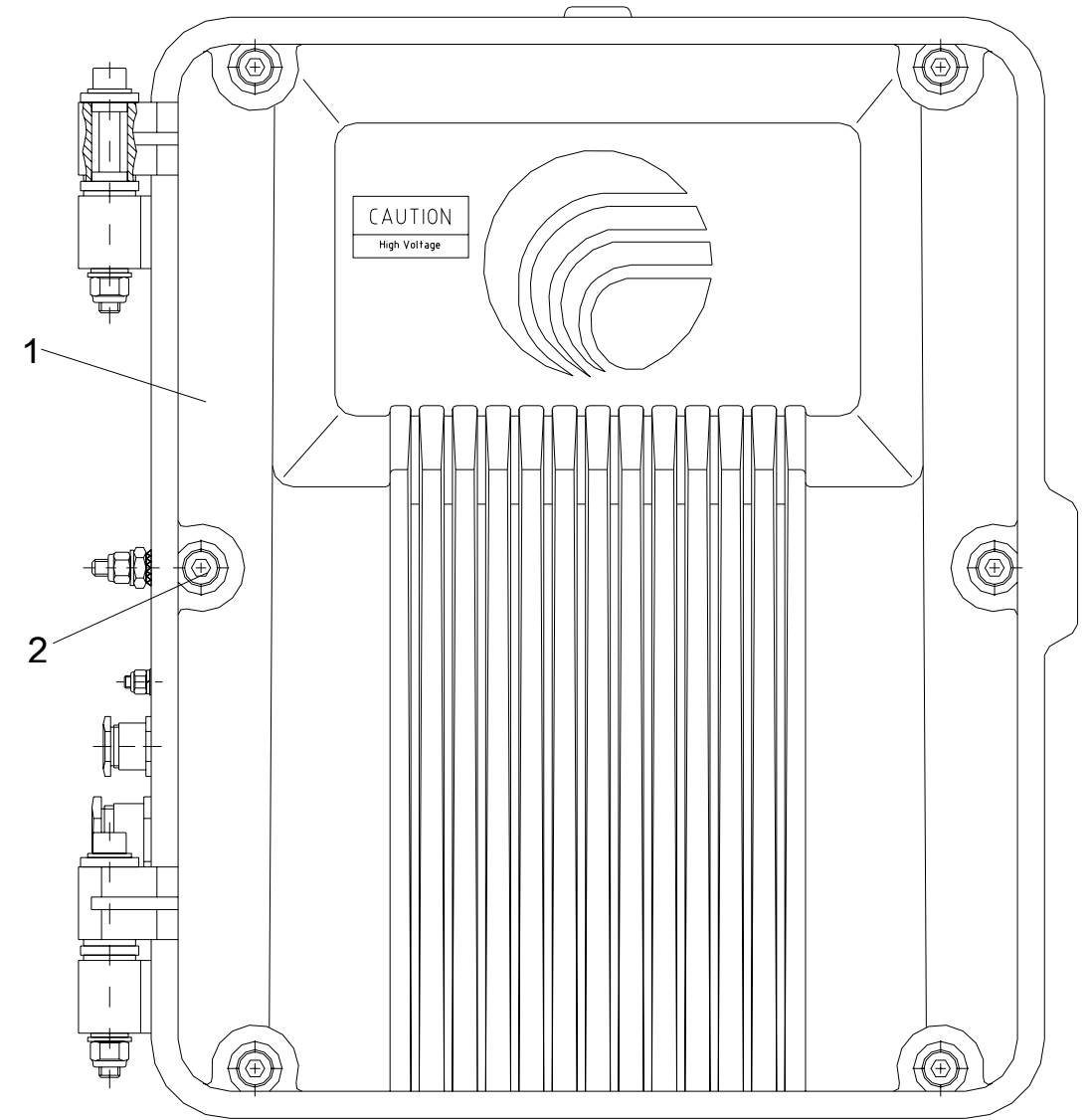

Figure 9.1.29 RTM 30S/U/D Unit - External View

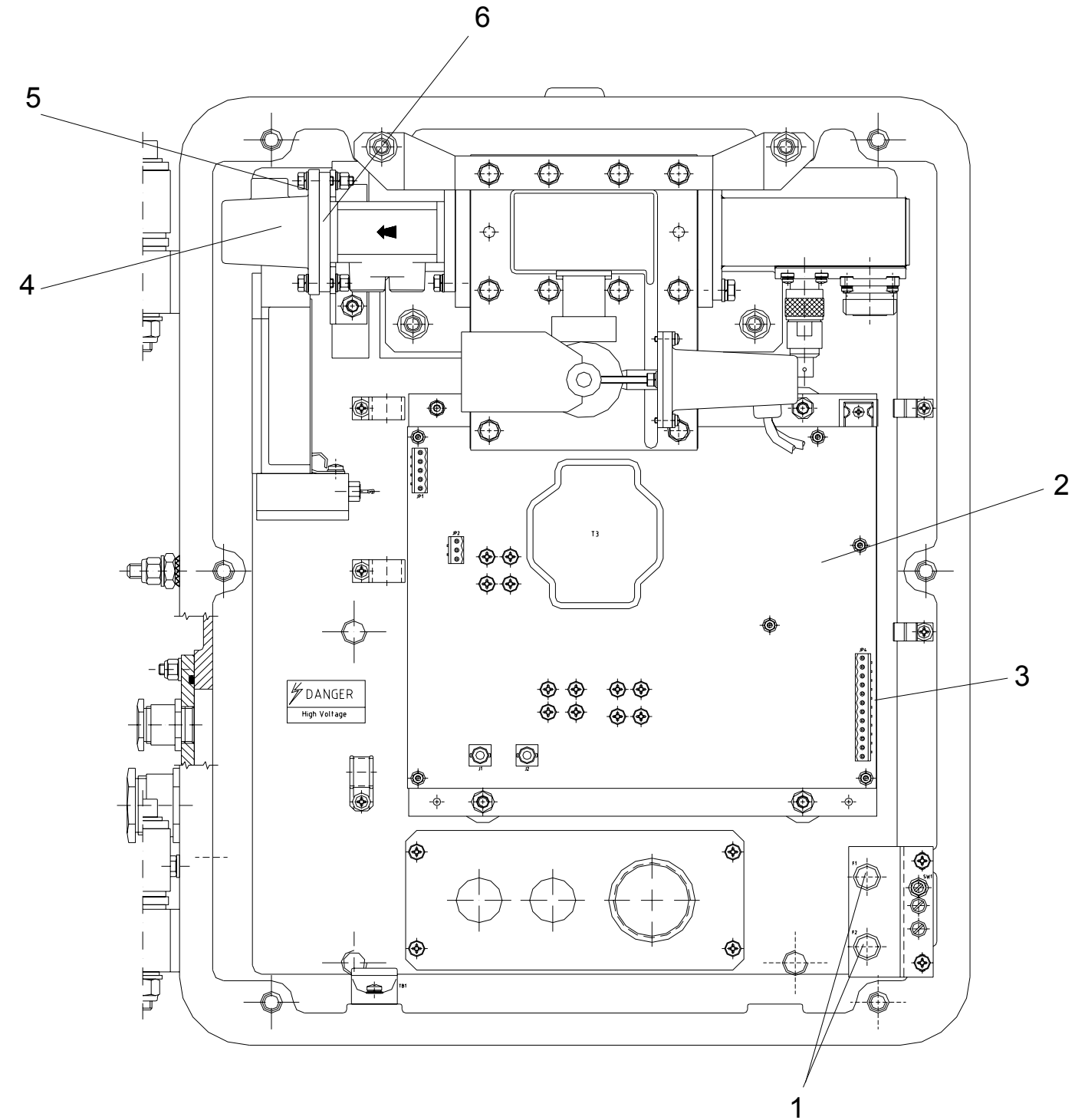

Figure 9.1.30 RTM 30S/U/D Unit - Internal View

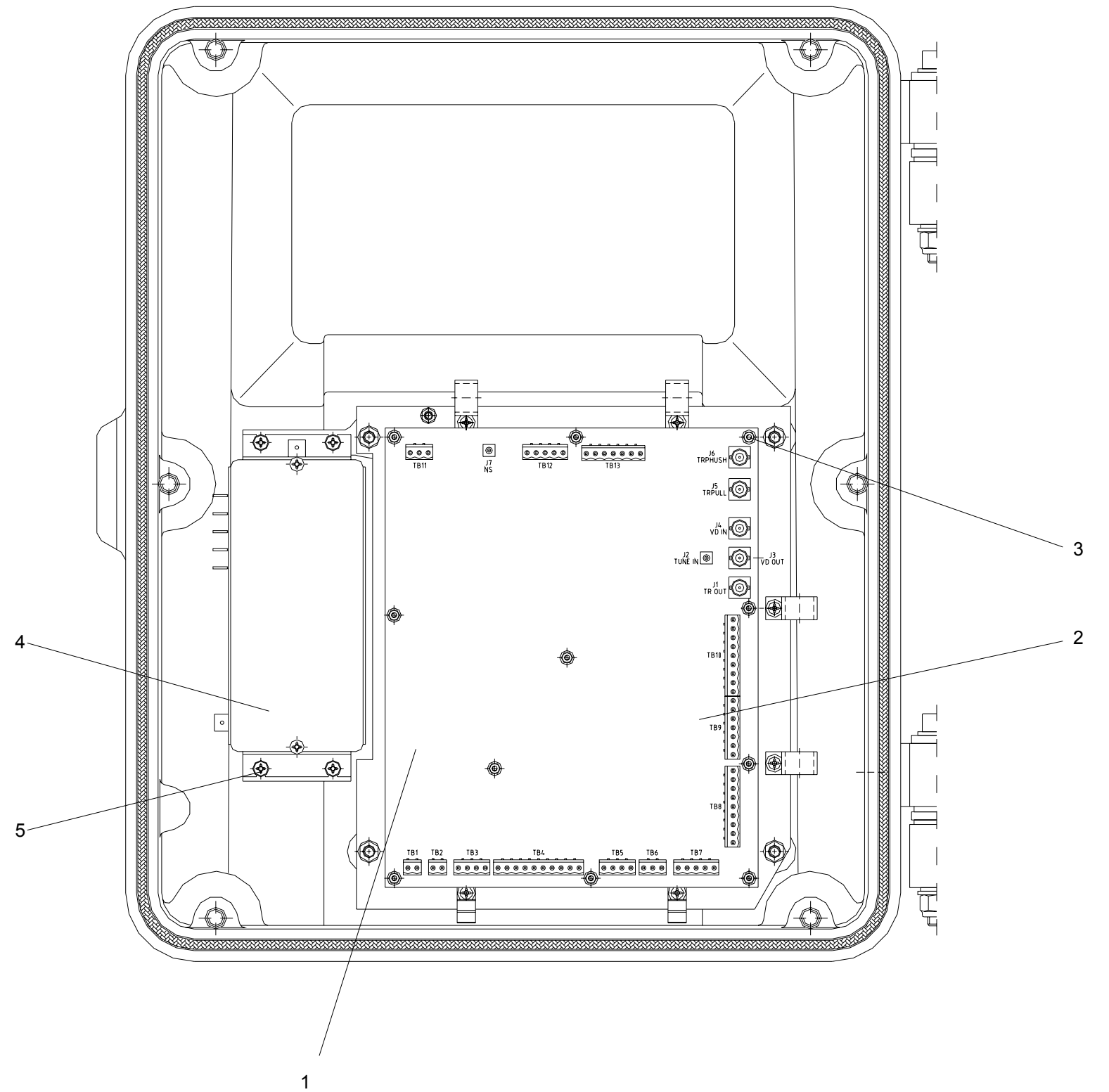

Figure 9.1.31 RTM 30S/U/D Unit - Internal View of the Cover

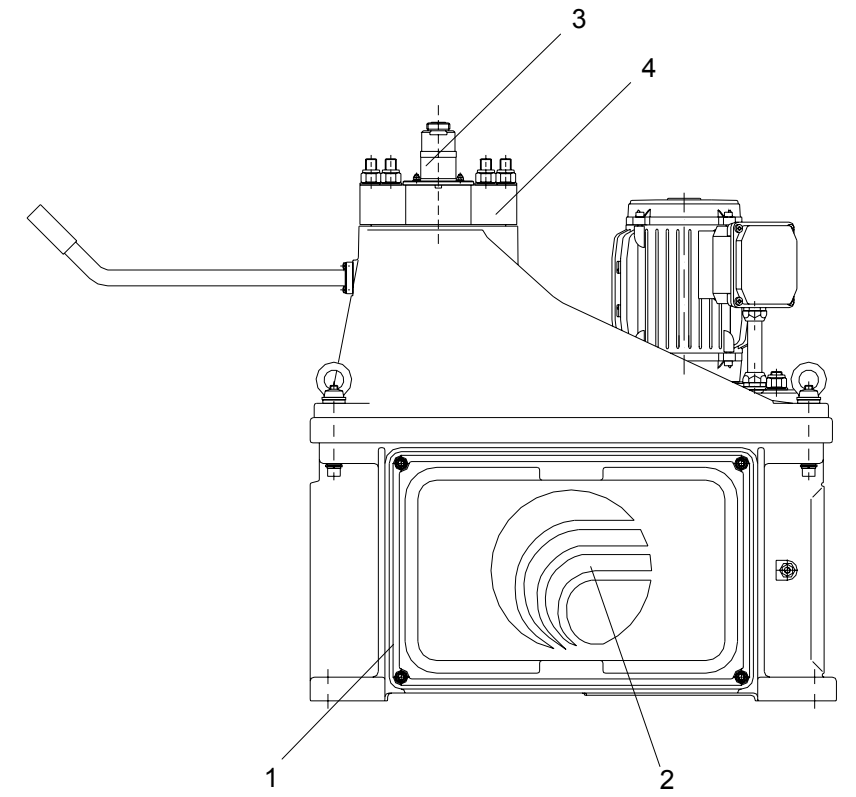

Figure 9.1.32 Antenna Pedestal S/U Unit with Performance Monitor - External View

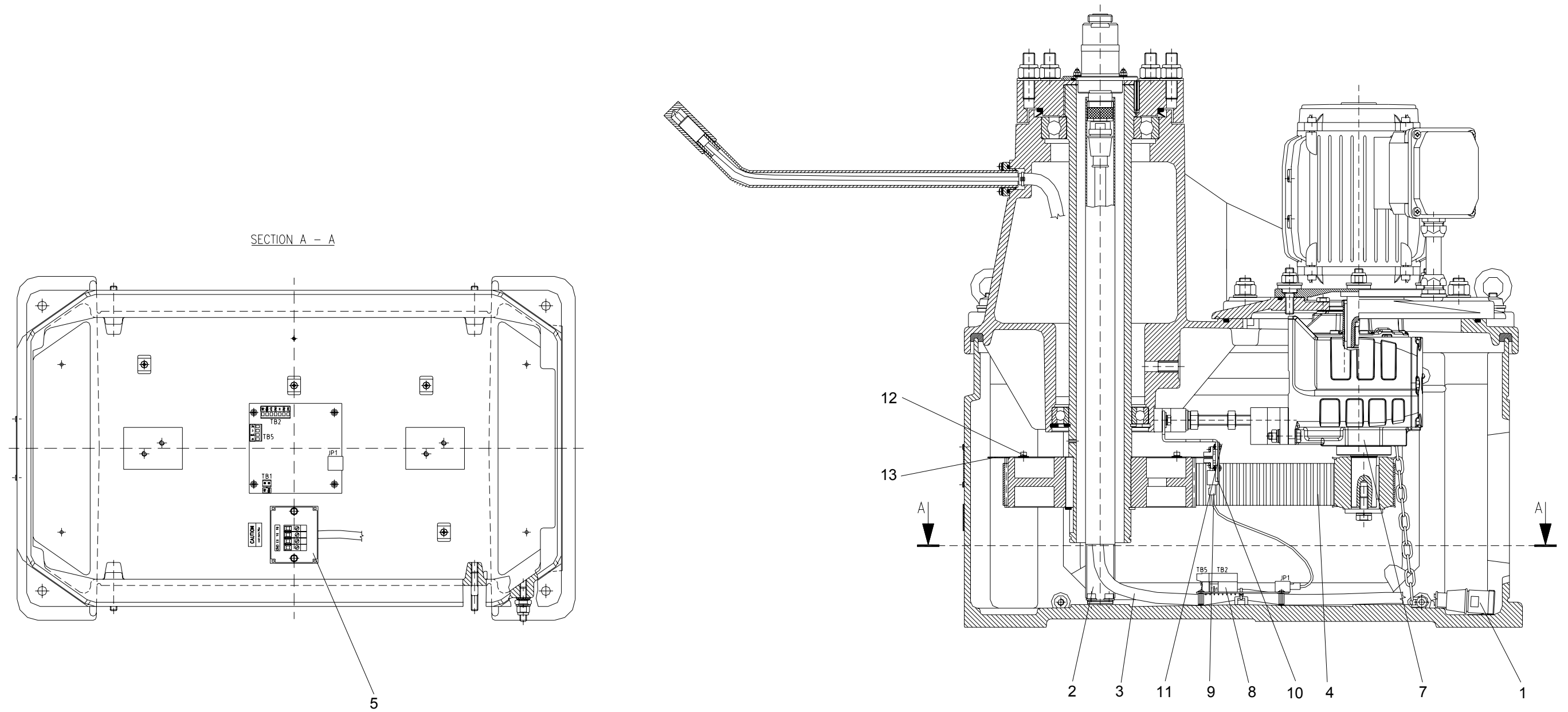

Figure 9.1.33 Antenna Pedestal S/U Unit - Internal View

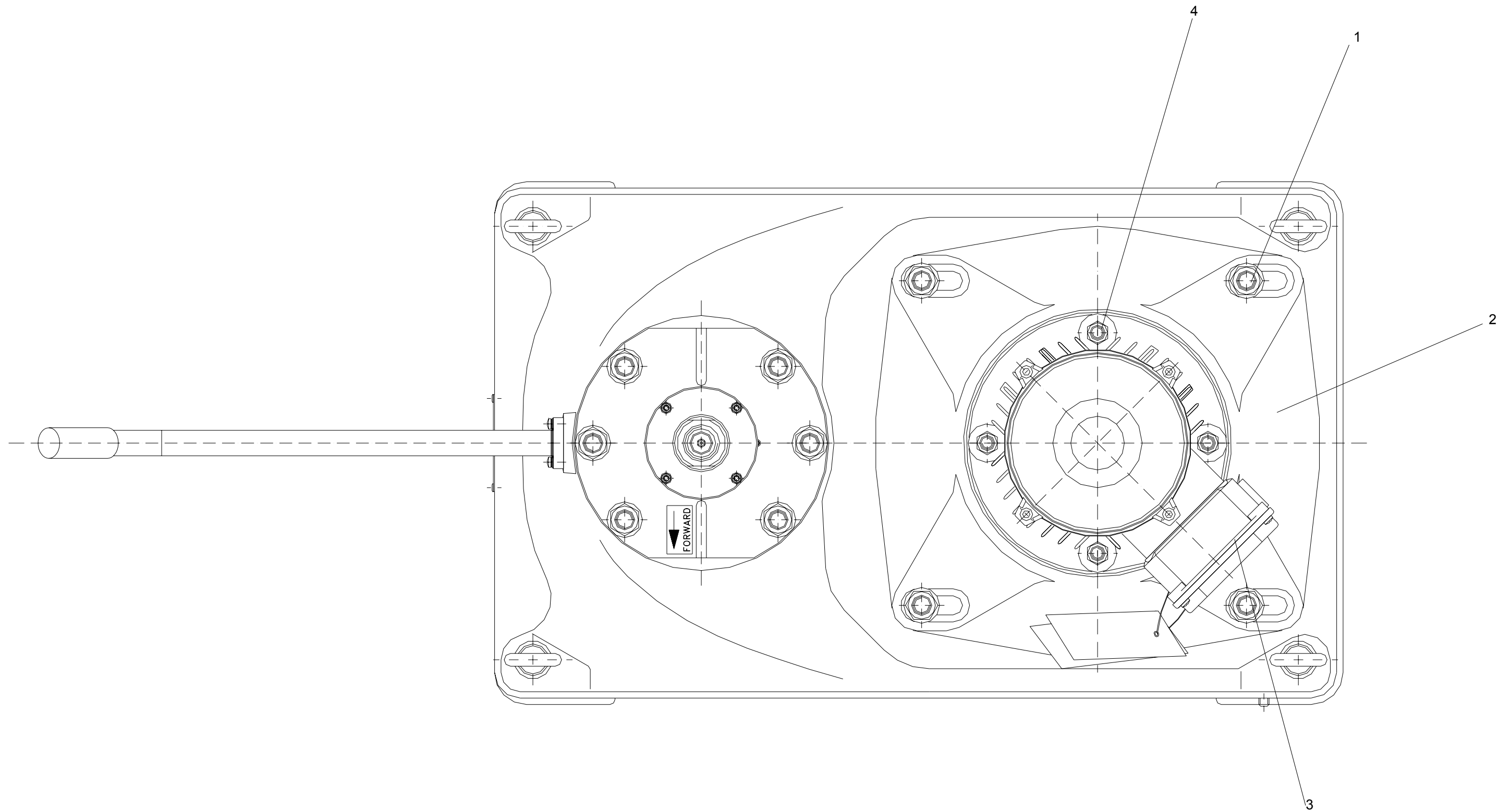

Figure 9.1.34 Antenna Pedestal S/U Unit - Particular of the Motor

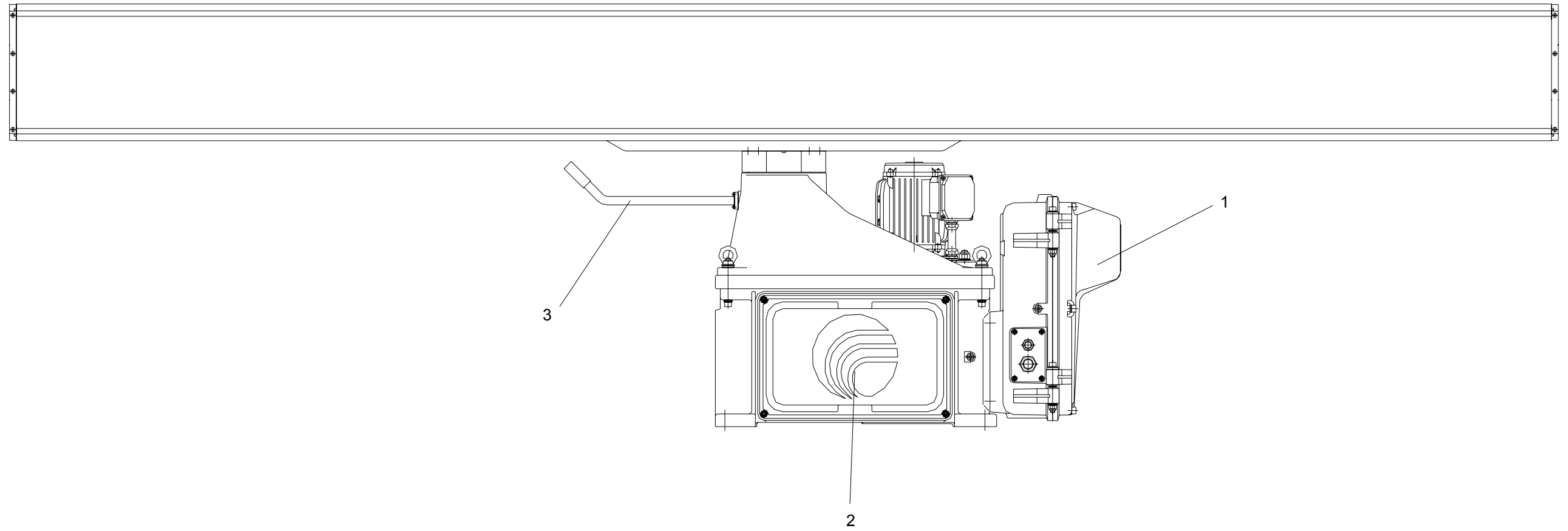

Figure 9.1.35 30 kW S-BAND/U Antenna Group

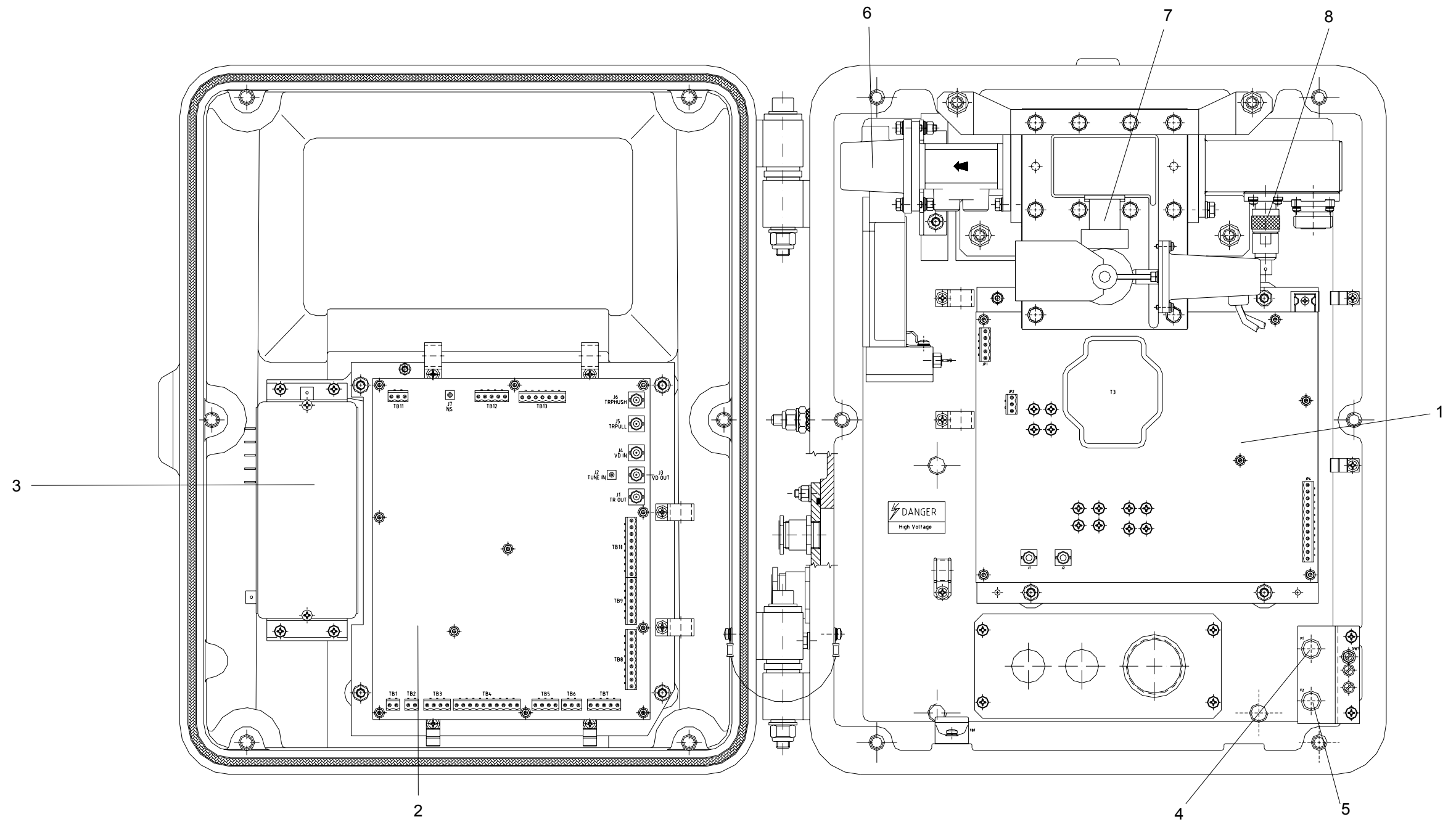

Figure 9.1.36 RTM 30S/U/D Unit - Internal View

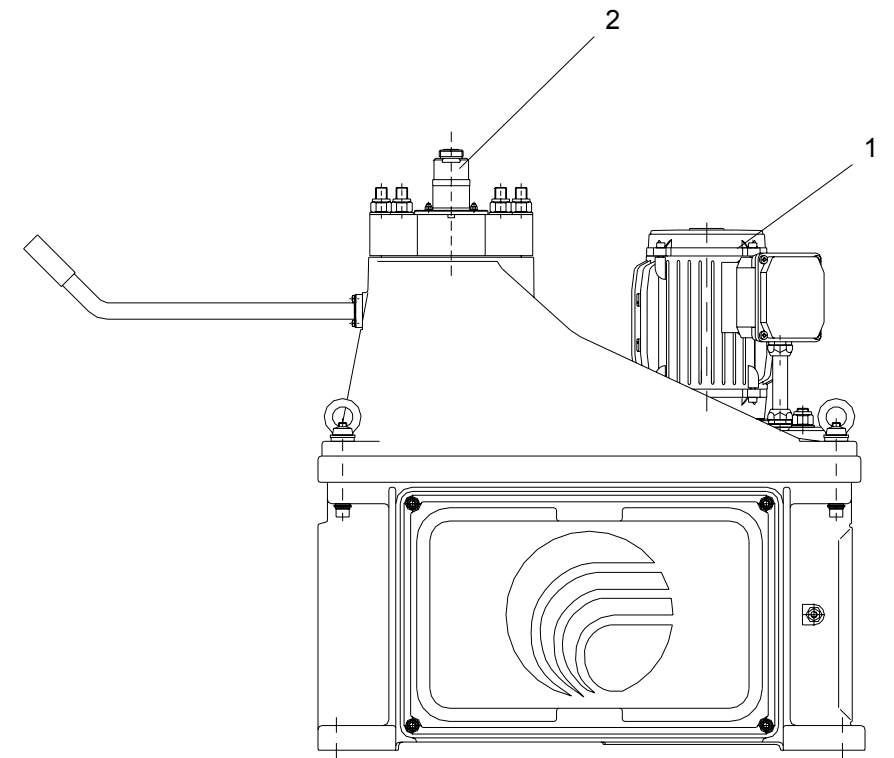

Figure 9.1.37 Antenna Pedestal S/U Unit Normal Speed - External View

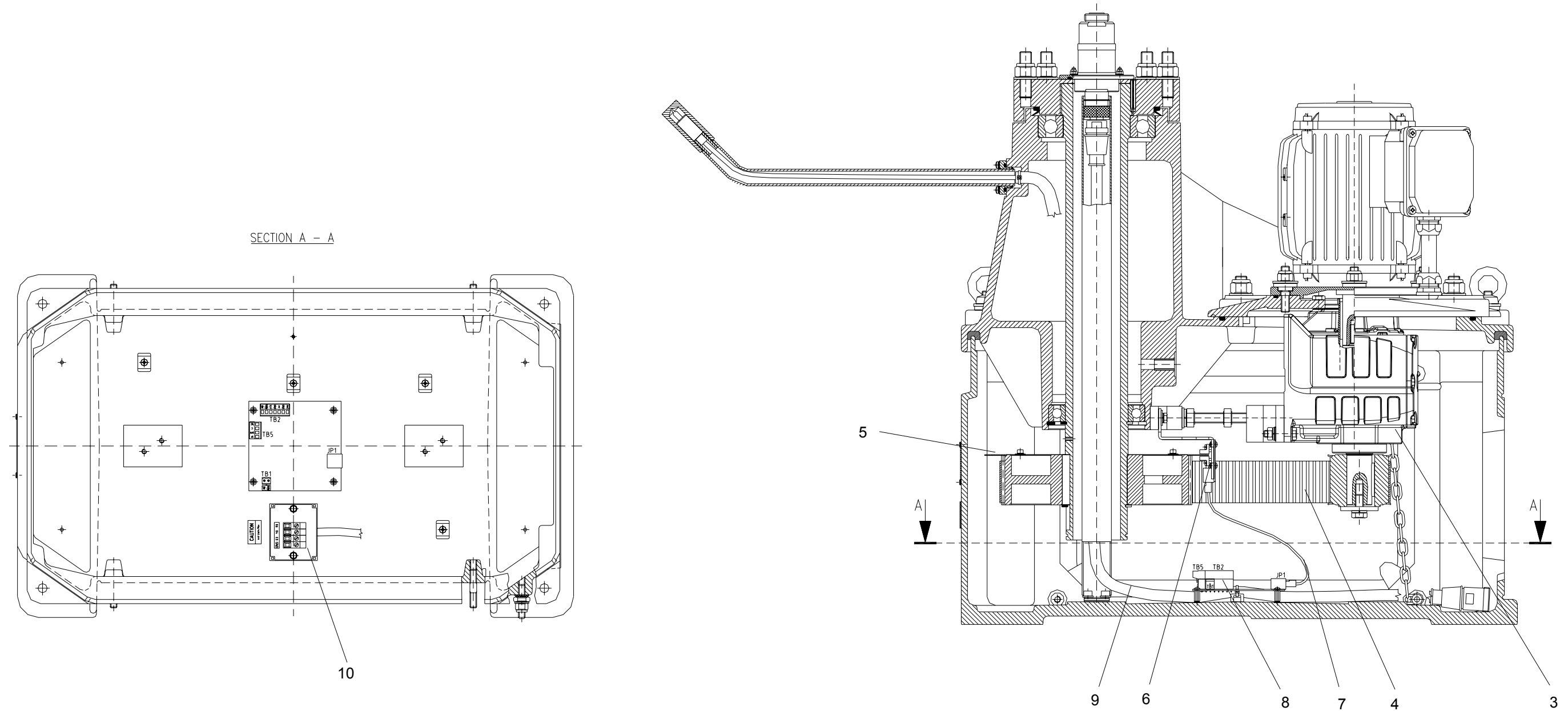

Figure 9.1.38 Antenna Pedestal S/U Unit Normal Speed - Internal View